

AD-A087 124

MARTIN MARIETTA AEROSPACE ORLANDO FL MICROELECTRONICS LAB F/6 14/2
COMPUTER AIDED AUTOMATED HYBRID SUBSTRATE PROBE TESTING DEVELOP--ETC(U)
MAR 80 C D GILL, R E SULOUFF DAAK40-78-C-0299
OR-15908 ML

UNCLASSIFIED

1 of 1
9/1/84

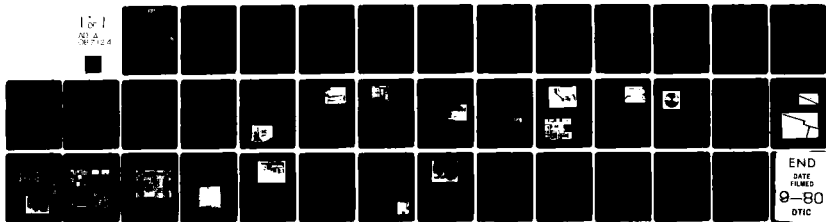

LEVEL III

2
K

ADA 087124

COMPUTER AIDED AUTOMATED
HYBRID SUBSTRATE PROBE TESTING
DEVELOPMENT

Final Report

Contract: DAAK40-78-C-0299

DTIC
EXTRACTED
JUL 23 1980
D
C

Prepared for

US Army Missile Research
and Development Command
Redstone Arsenal, Alabama

DDC FILE COPY

Martin Marietta Aerospace
Orlando Division
Post Office Box 5837
Orlando, Florida 32855

This document has been approved
for public release and sale; its
distribution is unlimited.

80 \$ 8 007

UNCLASSIFIED

SECURITY CLASSIFICATION OF THIS PAGE(When Data Entered)

The applicability to multilayer thick film substrates suggest future adaptation as an in-line manufacturing or test technique.

UNCLASSIFIED

SECURITY CLASSIFICATION OF THIS PAGE(When Data Entered)

CONTENTS

1.0 Introduction 5

2.0 Technical Discussion 6

 2.1 Introduction 6

 2.2 Theory of Operation 6

3.0 Conceptual Design Phase 11

 3.1 Conceptual Design Process 11

 3.2 Alternative Approaches 12

4.0 Probing Technique Evaluation, Implementation Phase 14

 4.1 Experimental Equipment 14

 4.2 Test Techniques and Procedures 17

 4.3 Test Demonstration 20

5.0 Technique Improvement and Optimization 29

6.0 Conclusions and Recommendations 32

References 33

Accession For	
NTIS GRA&I	<input checked="" type="checkbox"/>
DDC TAB	<input type="checkbox"/>
Unannounced	<input type="checkbox"/>
Justification	<i>Per FI-12</i>
By	<i>file dtd 14</i>
Distribution/	
Availability Codes	
Dist	Avail and/or special
<i>R</i>	

ILLUSTRATIONS

2.2-1	General Diagram of Probing System.	7
2.2-2	Secondary Electron Emission Yield of Gold.	8
2.2-3	Primary Current as a Function of Surface Potential	8
2.2-4	Total Secondary Yield Curve.	9
2.2-5	Secondary Emission Yield as Function of Angle of Incidence . .	10
3.1-1	Conceptual Design of Substrate Prober.	13
4.1-1	Test Equipment (Scanning Electron Microscope).	14
4.1-2	Substrate Insertion into Chamber	15
4.1-3	Test Tool for Beam Control	16
4.1-4	Multipoint Probe Tooling Schematic	16
4.1-5	Faraday Cup Mounted for Beam Current Measurements.	17
4.2-1	Optical Photograph of Thick Film Substrate	18
4.2-2	Composite Secondary Electron Image of "Charged" Thick Film Conductor	19
4.2-3	Multilayer Thick Film Substrate.	19
4.2-4	Composite Secondary Electron Image of "Charged" or Probed Thick Film Substrate.	20
4.3-1	Relationship of Metalizations Analyzed to each other	21
4.3-2	Probed Substrate Point 2 Charged, Points 1 through 7 Scanned and Analyzed	21
4.3-3	Two Substrates Probed with Electron Beam	22
4.3-4	Substrate 005 Ground or Reference Energy State	23
4.3-5	Substrate 005 Metalization Charged or Probed to Indicate Continuity.	23
4.3-6	Charged Metalization of Multilayer Substrate	23
4.3-7	Substrate H792	24
4.3-8	Multilayer Substrates for Evaluation of Surface Topography on Probing Techniques.	25
4.3-9	Thin Film Substrate.	26

4.3-10	Overall Substrate.	27
4.3-11	X-Ray-Generated Substrate Image.	27
4.3-12	Secondary Electron Image of Probed Substrate	28
5.0-1	Test Technique Improvement by Level Differentiations	30
5.0-2	Test Output of Testing Metalization Pattern.	30
5.0-3	Example of Buried Metalization Path Imaged through the Dielectric	30
5.0-4	Another Example of Charged Buried Metalization Path Imaged through the Dielectric	31

SUMMARY

This document describes a method for nondestructive electrical testing of complex multilayer hybrid substrates. This method utilizes an electron beam to first charge the metalization and then to probe it for shorts and opens.

The method described has been proven to be feasible on a variety of thick film single and multilayer substrates both with and without resistors. However, it was unsuccessful on the thin film substrate tested, because the beam penetrated the metalizations and thus did not charge them.

It appears that this method could be suitable for universal tooling and high-speed testing of substrates in a manufacturing situation. Further study will be necessary to determine the feasibility of this proposition.

1.0 INTRODUCTION

Thick film hybrid substrates often incur short circuits and opens during the manufacturing process. Opens are caused by lint and other blockages on the printing screen. Shorts occur either as a result of pinholes in the dielectric or smears during printing. These defects are not always detected in a visual inspection of the substrate; pinholes, in fact, are often impossible to detect visually. It is also very costly and time consuming to make a 100-percent visual inspection of multilayer hybrid substrates after each layer is printed.

Because of this high cost, multilayer hybrid substrates should be tested electrically to remove the defective substrates. This is usually done by manual probing or by use of probe cards. These methods, however, have several disadvantages. Because of the density of multilayer hybrid substrates, it is sometimes difficult to contact all the required probe points and thus to test it adequately for all defects. Mechanical contact probing, aside from the cost of probe cards, can also damage the substrate by chipping and scratching the thick film conductors, causing yield loss through the very process of testing.

These disadvantages could be eliminated by a method of probing thick film substrates without making contact with them. This report discusses a noncontact probing procedure that utilizes an electron beam and a secondary electron emission from the substrate to inspect the conductors for shorts and opens.

The electron beam is produced with an electron gun which can be focused and manipulated in such a manner as to charge a thick film conductor, scan it for shorts and opens, and then to discharge the conductor. The beam potential is varied so that the surface potential of a particular conductor can be made different from the other conductors on the substrate. This causes the resulting secondary electron emission to differ from the other conductors, making it possible to check the continuity of the conductor without physically contacting the substrate.

Each material has its own secondary electron emission characteristics, which are dependent upon the potential of the primary electron beam, the surface smoothness of the material, and the angle of incidence of the primary beam. Therefore, the ceramic, dielectric, and thick film conductors are easily distinguished from each other.¹

2.0 TECHNICAL DISCUSSION

2.1 Introduction

The purpose of this effort, as stated in the technical requirement of contract DAAK40-78-C-0299, is "to develop techniques, procedures, and special tooling to test thick film substrates for shorts or opens before submission to next assembly level."

The present techniques employed for this process of testing substrates typically employ visual inspection of each layer of conductor pattern and dielectric as they are fabricated. The electrical probing with needle- or spring-loaded probes is often done after the substrate fabrication is complete. The combination of visual inspection and probing can become a significant cost in substrate production, as additional layers and successive complexity push the probability of a failed substrate above acceptable levels. As the complexity increases, the added substrate value makes substrate testing more important. Unfortunately, in present multilayer hybrid substrate designs, the complexity makes probing with the conventional mechanical probing method of a needle- or spring-loaded probe a cumbersome task.

In an effort to find an alternative to the mechanical probing problems of complex multilayer substrates, a new method was developed. This new method involved a contactless technique whereby a focused beam of electrons was directed onto a substrate and used to probe for opens or shorts. Due to the developmental nature of this method, the primary effort of the technical task was to explore application to the probing of multilayer hybrid substrates. The investment in production tooling and high throughput was considered from a long-term perspective, with primary effort and study focused on the development of basic technique and its applicability. Many technical obstacles had to be overcome for the successful performance of such a task. The possibility of a truly universal probing method fully defined by computer software and keyed to the pattern under test made this technical effort especially significant.

The initial discussions in this report center around the theoretical aspects of the technique. The theory of operation can thereby provide the background for a complete understanding of the effort undertaken.

2.2 Theory of Operation

The probing of the substrates using a contactless method relies upon a few basic physical interactions of electrons and matter. The overall

approach is to generate a focused beam of accelerated electrons with kinetic energies in the 2- to 20,000-electronvolt (eV) range. The focused beam typically of a few nanoamperes strikes the surface of the designated metal pattern at a predetermined point. The injection of electrons into the conductor results in a buildup of charge (assuming no low impedance path to ground potential)^{2,3,4,5}. The generation of secondary electrons from such a conductor is enhanced if the surface potential of the conductor is negative with reference to the uncharged state.¹ Correspondingly, the generation of secondary electrons is impeded if the surface potential becomes positively charged with respect to the ground or uncharged states. This induced charge and the corresponding voltage contrast effect are used to probe the substrate for shorts and opens.⁶

A more detailed explanation of the technique is necessary to fully define the critical parameters of the process. The general diagram of the probing system is shown in Figure 2.2-1. The gun and lens system provides a focused electron beam with a primary beam current given as i_p . In providing a sign convention, the current i_p is always negative, being composed of primary electrons, with accelerating potential V_{EC} , strikes the sample in a spot where the surface potential is defined a V_x . A secondary electron current i_s , a negative current, is thus generated. The secondary electrons are attracted into a secondary collector at a positive potential V_{SC} . The generation of secondary electrons as a ratio of the primary electron is expressed by:

$$\delta = i_s / i_p \quad (1)$$

which typically reaches a maximum for a specified primary kinetic energy and material. This ratio can exceed unity under many cases and thus can result in more secondary electrons being generated than were originally present in the primary beam i_p . Figure 2.2-2 shows the secondary electron emission as a function of the accelerating potential of a typical electron primary beam.

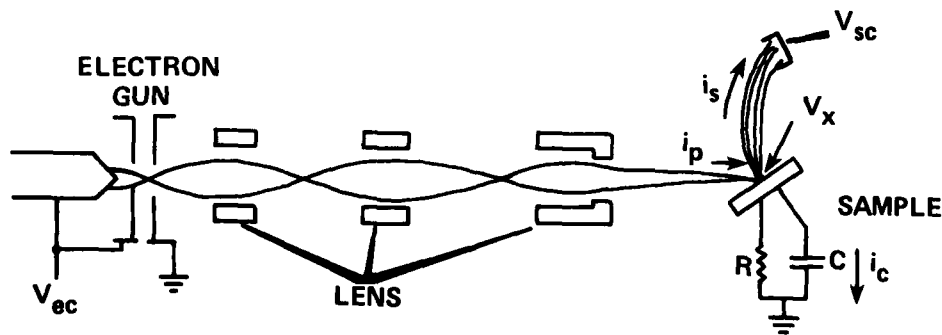

Figure 2.2-1. General Diagram of Probing System

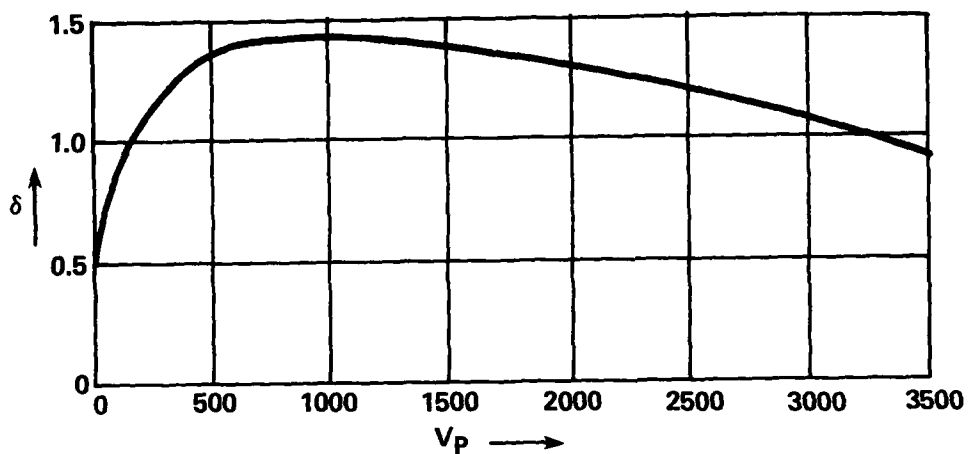

Figure 2.2-2. Secondary Electron Emission Yield of Gold

If the ratio of impedance to ground potential is significantly high, an equation of the currents at the sample surface can be expressed as:

$$i_p = i_s + i_c \quad (2)$$

where

i_c is the specimen current flow to ground.

The currents in Equation (2) can be expressed as different functions of the surface potential V_x . Successful operation of the probing technique is dependent on careful evaluation of these functions. The function $i_p \cdot (V_x)$ appears electrically as a current source of value i_p , which cuts off sharply at $V_x = V_{EC}$ (at least for first-order considerations) as shown in Figure 2.2-3.



Figure 2.2-3. Primary Current as a Function of Surface Potential

The secondary current i_s is calculated from the experimentally established total secondary yield curve shown in Figure 2.2-4.

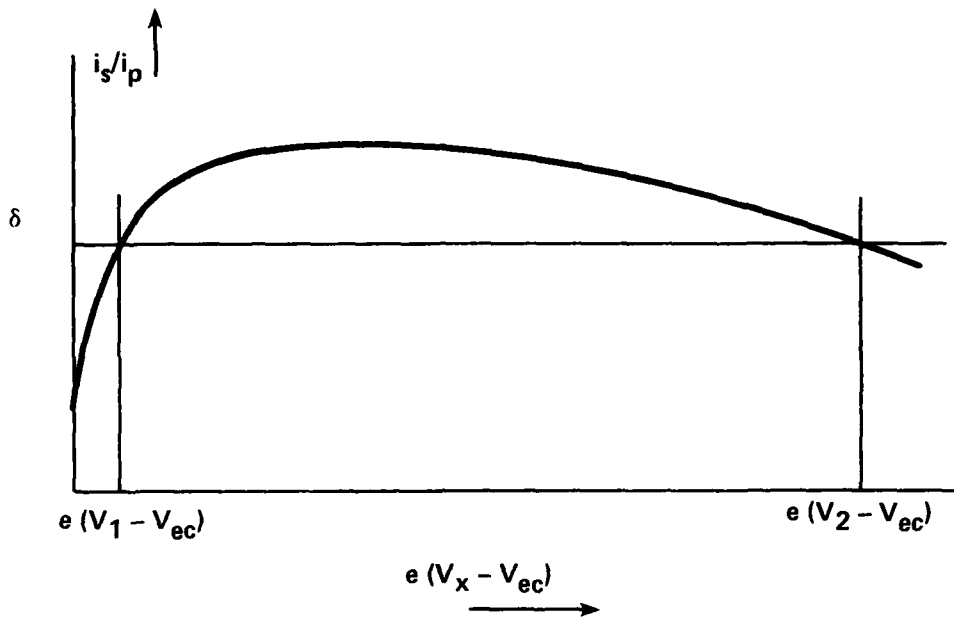

Figure 2.2-4. Total Secondary Yield Curve

Assuming that all secondary electrons are collected by the large positive potential on the secondary detector, Equation (1) substituted into Equation (2) yields:

$$i_p = i_s + i_c \quad (2)$$

$$i_p - i_s = i_c = i_p - i_p \left(\frac{i_s}{i_p} \right)$$

$$i_c = i_p (1 - \delta) \quad (3)$$

The Equation (3) has several significant points. First, in the case where $i_c = 0$ or the very high ratio of impedance to ground results in a floating sample, the net current to the specimen's surface (i_x) is equal to the difference between the primary and secondary electron currents. This difference value can be positive or negative depending upon the secondary electron yield value. The surface potential V_x is thus controlled by the secondary electron yield. Since the secondary electron yield is a function of the accelerating potential, a technique to control the potential V_x by controlling the accelerating potential of the electron primary beam evolves. The magnitude of the primary current i_p will control the buildup of charge or surface potential as a function of time. Interestingly, the

discharge of the surface due to the secondary electron yield exceeding unity can result in a positive charge, and the corresponding discharge of the surface potential, which had been created by an electron emission yield of less than one, can generate a negative charge.

The theoretical possibility exists that the surface potential of a sample can be controlled by varying the kinetic energy and the total beam current of an electron probe; thus voltages could be written onto the surface of a substrate.⁷

There are other factors to be considered in the theoretical operation of such a probing technique. The secondary emission yield varies considerably with angle of incidence of the primary electrons, as illustrated in Figure 2.2-5. This effect can become pronounced when a rough or irregular surface is probed by the electron beam. The charged or discharged state could be changed by the difference in the angle of incidence.

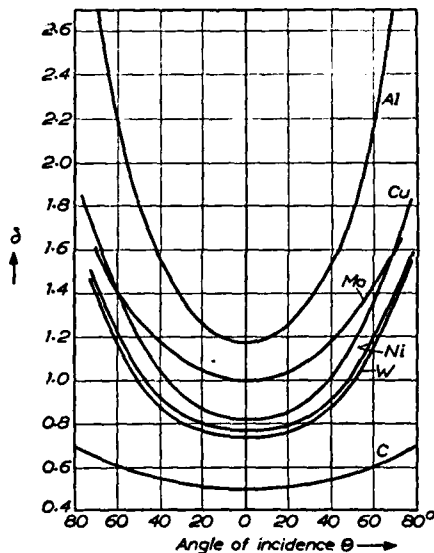

Figure 2.2-5. Secondary Emission Yield as Function of Angle of Incidence

An additional key factor in the performance of the electron probing technique is the influence of contamination on the generation of secondary electrons. Due to the fact that the secondary electrons are generated within a few hundred angstroms of the surface, the area probed must be very clean and free from surface contaminants. The voltages imposed by the electron beam probing technique are highly dependent upon the surface leakage to ground, and irregular probing results can appear if the substrate is not free of contaminants.

These factors, along with the variability in layout and probing technique, are important considerations in the probing of substrates using the noncontact method. The results of the substrate probes and the interpretation of the experimental findings will provide the data needed to extend the basic theoretical discussion to an application-oriented set of recommendations.

3.0 CONCEPTUAL DESIGN PHASE

3.1 Conceptual Design Process

The design requirements of a Computer Aided Automated Hybrid Substrate Probe are defined in Contract DAAK40-78-C-0299 for the technical effort as:

"... automated, computer controlled probe system suitable for electrical probe of thick and thin film substrates. The system will incorporate substrate selection techniques which allow preprogrammed probe positions and tooling on an individual substrate basis. The automatic selection technique shall require only the designation of substrate identification, thus utilizing universal probe tooling."

The conceptual design effort will be performed to define the key elements of the substrate prober and the interaction of these elements for probing of the substrate. The electron beam technique used for the probing lends itself to a computer-controlled process in which the probe is placed in the proper location and sequenced through the positions to be investigated. The processing of the signal derived from the probing operation is correlated using the computer. A predetermined set of signal conditions which correspond to a good substrate is kept in memory. The ease of electron beam movement by a magnetic field is an important factor in the ability of the system to universally probe substrates.

The probe used for the conceptual design is to be a beam of electrons accelerated in the 2 to 30 keV range.

The overall design of the electron column is intended to be a multilens system that has thermionic emission from a hairpin-type tungsten filament. Using a Wheltnor gun design typical of many modern electron microscope assemblies, stable electron source is constructed. The added features of a beam blanking circuit and a control grid are necessary for an electron probe. The deflection of the electron beam outside the field of view of the intermediate lens assembly will in effect turn the electron probe off until a new set of coordinates is selected for probing. The gun assembly and beam blanking are followed by an electron lens assembly to assure the proper focus of electrons over the substrate surface. This electron beam is moved to points on the substrate by using a set of scan coils that deflect the focused electron beam. The use of an appropriate analog-to-digital mapping scheme would thus give a digital address to every resolvable point in the field of view of the electron beam. The digital address and the corresponding time increment would be selected by the computer program to probe a point, and the complete probing sequence would thus result in a probed substrate.

The proper control of a electron beam focused onto the points of a substrate results in the transfer of energy to the designated electrical node. The successful probing operation requires a subsequent effort to extract data on the condition of a particular node. The design of the prober is intended to include an accurate energy filter and secondary electron detector. The collection of secondary electrons of particular energy levels and the corresponding magnitude of this electron flux or current is rather easily accomplished. A grid structure with adjustable potentials is built along with a trajectory path that eliminates the higher energy, backscattered electrons. The resulting secondary electron current sensed (collected) is directly proportional to the potential of the surface where the secondary electrons are generated. If careful attention is given to eliminate material and topological effects, an accurate measurement of surface potential can be derived. Typical secondary electron detection techniques utilize a scintillation and photomultiplier scheme to derive a voltage proportional to the number of secondary electrons. This voltage is in turn related to the surface potential of the probed point. The digitizing of the analog voltage output of the photomultiplier and head amplifier gives a digital value for the probed point. The conceptual design is intended to correlate this voltage level to a corresponding condition in the truth table of a "good" substrate, and to derive a pass-or-fail signal. Current literature describes this as the voltage contrast technique.

The loading of substrates into a feed mechanism and the automatic pumpdown is an important feature of the design. The interlock method, whereby a chamber is always maintained at the desired vacuum level and substrates are passed into the chamber via an air lock, is key to the parts transfer method. A carrier and feed mechanism would be loaded in normal room ambient and placed in an interlock chamber of pumpdown. When the proper vacuum level is reached, the substrates would be shuttled into the test chamber. Thus, through several interlock chambers, reasonable production levels of substrates could be tested. The computer system would also monitor the substrate loading and unloading, and would control the proper flow and sequencing of parts.

Figure 3.1-1 is a conceptual design of the system with the key elements shown. The exact mechanisms, hardware, and measurement algorithms are not specifically defined due to the exploratory nature of this effort. As the physical parameters are better defined through careful experimental efforts, a more complete conceptual design will be developed.

3.2 Alternative Approaches

The electron beam probing technique for the evaluation of multilayer substrates is a unique technical approach. Other, more conventional approaches to substrate probing were also considered.

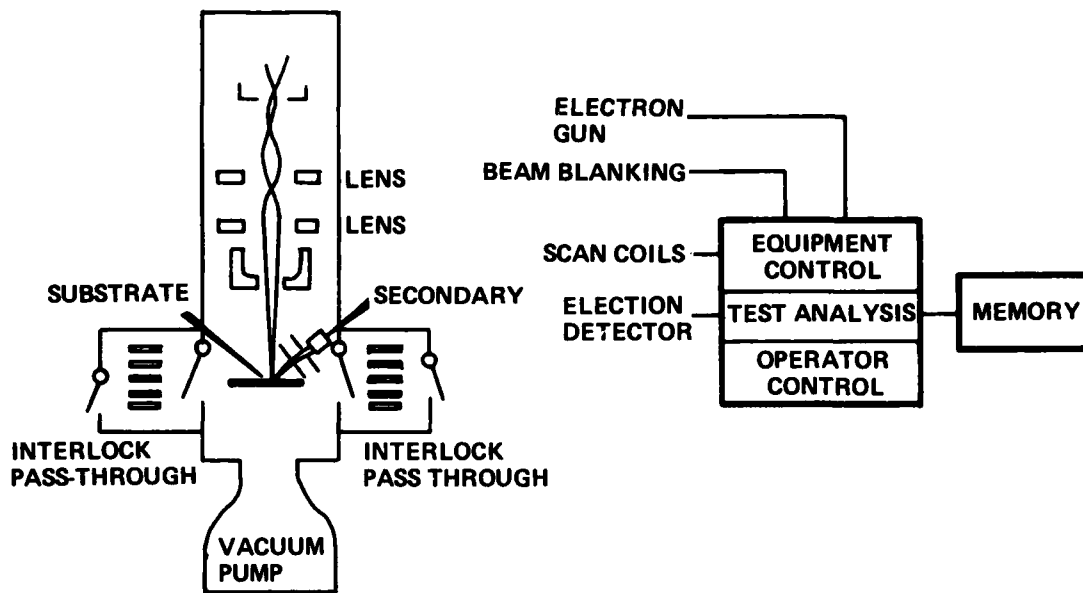

Figure 3.1-1. Conceptual Design of Substrate Prober

The technique of using a series of probes to make mechanical contact with the substrate was evaluated. This contact method was not developed due to the complexity of the probing method and interface considerations. If this bed-of-nails concept is used, universal tooling can be provided. This approach could supply probes at standard points throughout the contact plane. The uncertainty in contact resistance and the wearout of such a technique were considered to be important factors.

The use of infrared techniques utilizing analysis of thermal conductivity was considered. The concept in such a technique is to illuminate the point to be probed with a focused laser beam. The localized heating of the metalization pattern would result in a change in surface temperature. The determination of continuity was conceived to be by means of an infrared imaging system. This technique, although feasible from a continuity checking standpoint, relies on thermal conductivity for measurement. The time constants associated with thermal diffusion are relatively large, and it was determined that rapid probing of multilayer substrates would be very difficult.

The use of high-frequency radiation coupled into a metalization pattern was an alternate technique considered. The conceptual approach was to use the metalization pattern as an antenna or waveguide, sensing with a detector placed in the proximity of the metalization pattern under test. The difficulty of coupling high-frequency energy into a metalization pattern and the problems associated with imaging or sensing the energy were determined to be controlling items in this design approach. The identification of electromagnetic fields to the close tolerances of microelectronic substrates was also identified as an area of difficulty.

4.0 PROBING TECHNIQUE EVALUATION, IMPLEMENTATION PHASE

The discussion of the probing technique used in this technical effort has been included in Section 2.2. The probing of a multilayer substrate with a focused electron beam and the corresponding analysis of the secondary electron yield is the essence of the technique. The adaptability of this method for cost-effective testing of multilayer substrates can only be determined by a careful evaluation of the probing technique.

4.1 Experimental Equipment

This section of the report discusses the equipment used to evaluate the probing technique and the tooling developed. The exploratory nature of this effort required the use of equipment capable of operation over a range of conditions on several substrate types. The adaptability of the Cambridge Steroscan S-4 to such an effort proved to be very effective. The S-4's electron gun, accelerating potential, and three electron lenses are controllable over a range of operating conditions.

The basic equipment setup as shown in Figure 4.1-1 involves the electron microscope and the associated test tooling to direct the beam to the pre-assigned points on the substrate. The introduction of the substrate into position in the test chamber of the microscope is easily accomplished by attachment of the back of the substrate to a standard specimen mount using some type of adhesive. The standard controls over the specimen allow for linear x, y, z motion and tilt and rotation of the substrate. Figure 4.1-2 shows the substrate attached to the stage mechanism and being inserted into the specimen chamber.

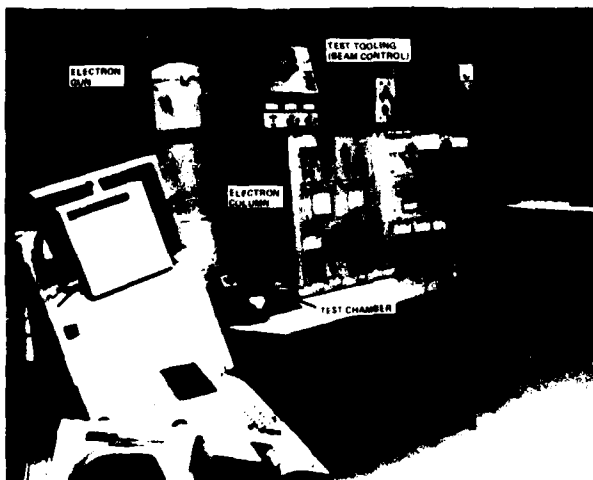

Figure 4.1-1. Test Equipment
(Scanning Electron Microscope)

Figure 4.1-2. Substrate
Insertion into Chamber



With the substrate positioned under the electron beam, a command is initiated to evacuate the test chamber. This evacuation or pumpdown is accomplished automatically and results in a ready signal when the proper vacuum level has been reached. The generation of the primary electrons and their proper focusing to a probe point on the substrate is accomplished with manual control of the microscope's bias and lens current.

The primary electron beam is thus accelerated and focused on the substrate. The control of the position of the electron probe is accomplished with electromagnetic coils in the electron lens assembly. These coils typically allow a scanning operation to occur. The control of these opposing coils in current level and time phasing results in a line and frame scan of the subject area. The removal of current to the scan coils will result in a single "spot" of electrons in the center section of the specimen. The electron microscope typically has control over the scan coils via switch positions which determine the scan rates and alternate positions that allow external drive of the scan coils.

The design of external drive circuitry to allow definition of probe positions in the electron microscope was performed in this technical effort. Figure 4.1-3 shows the overall test tool control panel, and Figure 4.1-4 presents the schematic representation of the control circuitry. With this addition to the electron microscope, a means of substrate probing was possible. Although further development of electronic control functions would be necessary for production applications, all of the essential elements of probe control were designed into the tooling. The multipoint probe tooling provided a reference point and seven probe points for substrate evaluation. The selection of the position of each probe point was accomplished with independent x and y controls. The control of the dwell time on each point and the transfer time between probe points was also controllable. The control of an automatic or manual sequence allowed for the single step advancement for tooling control of the probing of the substrates. The tooling also allowed for either continuous scan of the seven chosen points or a single scan through all of the established points.



Figure 4.1-3. Test Tool for Beam Control

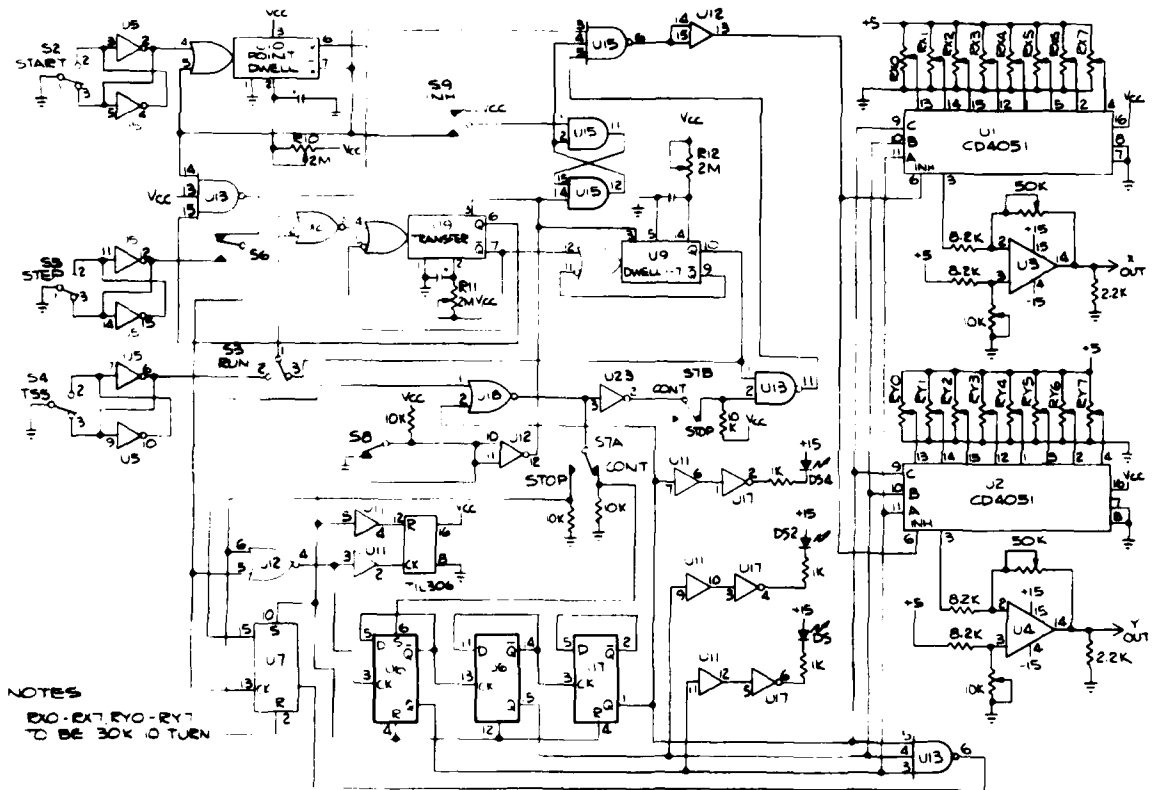

FIGURE 10
 SCHEMATIC OF THE MULTI-POINT PROBE TOOLING

Figure 4.1-4. Multipoint Probe Tooling Schematic

The evaluation of other critical parameters of the electron probe system was undertaken to assure accurate and repeatable experimental results. The characterization of the primary beam current using a Faraday cup and picoammeter provides proper correlation of electron optics with primary beam currents. Figure 4.1-5 shows the fabricated Faraday cup mounted in place of the substrate on the specimen stage. A complete characterization of the beam current versus electron lens currents and final aperture sizes was developed. It was found that repeatable beam currents from 5 nanoamperes to less than 0.3 picoamperes could be achieved by adjusting the lens focusing properties and final aperture sizes. Typical currents from 20 to 80 picoamperes were used for most probing evaluations. The evaluation of accelerating voltage was determined by correlating the response of the energy dispersive X-ray analysis (EDXA) equipment with the analog meter output on the high voltage supply of the microscope. The highest X-ray energy count in keV correlated very well with the indicated meter measurement over the range of 2 to 30 kilovolts.

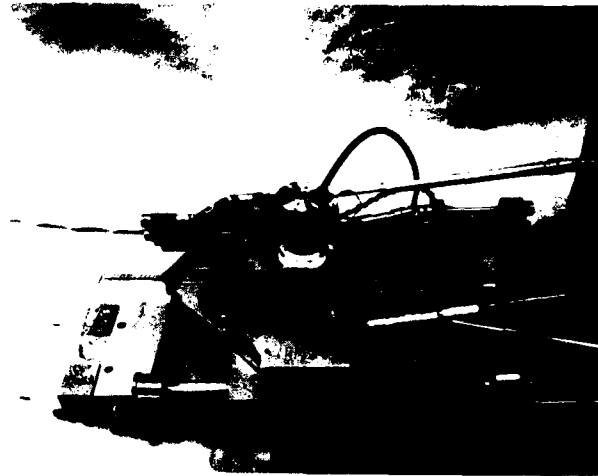

Figure 4.1-5. Faraday Cup Mounted for Beam Current Measurements

4.2 Test Techniques and Procedures

The application of the electron microscope and the associated probe tooling provides an effective means of controlling the electron beam. Sensing of the probed position on the substrate requires careful attention to other experimental factors. This section of the report describes the techniques and procedures developed to probe and evaluate the substrates under tests.

The sensing of the condition of a probed point on the substrate is accomplished by the use of a secondary electron detector. The scanning electron microscope is equipped with this detector. The detector is placed at the rear of the chamber and connected through a low noise amplifier to the signal conditioning circuitry of the microscope. The detector is constructed with an accelerating grid and a collector tip held at electrical potentials sufficient to filter out electrons of the undesired kinetic energy, but still adequate to collect the secondary electrons

which are generated by the primary beam. The secondary electrons strike a scintillation material and generate light photons which are subsequently passed into a photomultiplier tube and amplified. The generation of a composite of all of the scanned points on a sample are typically imaged using the data from the secondary electron detector. This signal is used to intensity modulate a raster scan on a cathode ray tube (CRT) and give an image of the sample. A photographic record of the image can also be provided. By using this equipment optimizing the signal for gain (brightness) and reference voltage offset (black level), probe point voltage levels can be sensed. The experimental equipment can therefore produce a focused electron beam of a range of accelerating potentials and current levels onto the surface of a substrate. The corresponding detection of the injected voltage level of the substrate surface with the secondary electron detector and associated circuitry is also possible.

The technique to accomplish this noncontact method is illustrated in Figures 4.2-1 and 4.2-2. Figure 4.2-1 is an optical photograph of a single layer thick film metalization pattern. The substrate was placed in the electron microscope and a charge was injected at the point illustrated by a beam of electrons of 50 picoamperes at 20 keV for a period of two seconds. This provided a "charged" condition throughout the entire metalization pattern. The accelerating potential was then reduced to 4.5 keV and the beam was scanned across the surface of the substrate. An image, shown in Figure 4.2-2, was produced with the secondary electron detector signal. The bright metalization pattern in Figure 4.2-2 shows the extent of continuity of the metalization pattern under study. It is important to realize that the metalization was probed at one point by the primary beam to achieve the charged condition, and that the image produced is from many sensing probes of the same substrate.

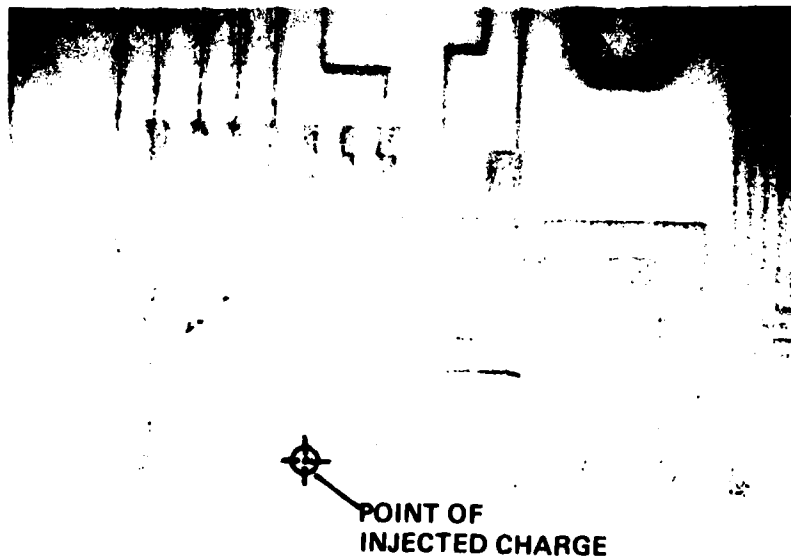

Figure 4.2-1. Optical Photograph of Thick Film Substrate

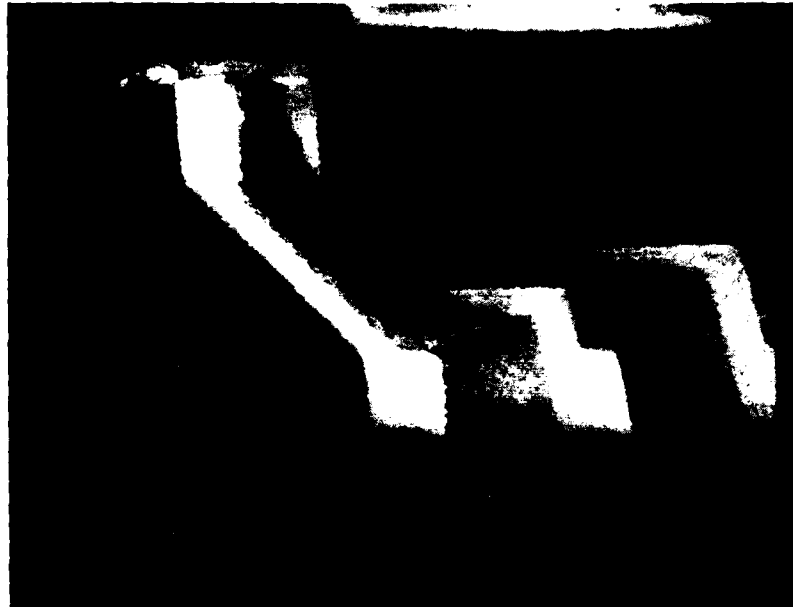

Figure 4.2-2. Composite Secondary Electron Image of "Charged" Thick Film Conductor

This technique for substrate probing is further illustrated using a multilayer substrate. Figure 4.2-3 shows an optical photograph of a portion of a multilayer metalization. The corresponding Figure 4.2-4 is an image produced from secondary electrons after the point indicated in Figure 4.2-3 was probed. The metalization under test can be seen to pass under the other metalization and continue on the other side of the multilayer region.

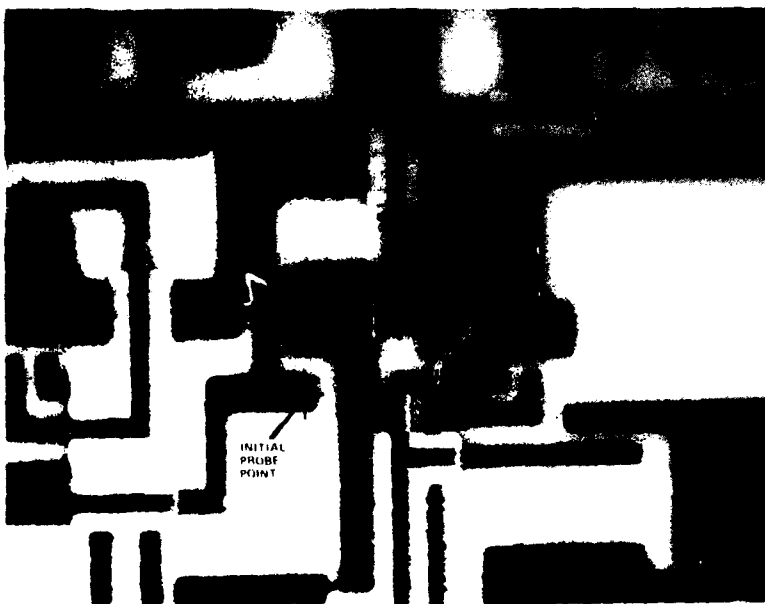

Figure 4.2-3. Multilayer Thick Film Substrate

Figure 4.2-4. Composite Secondary Electron Image of "Charged" or Probed Thick Film Substrate



4.3 Test Demonstration

The technique of contactless probing as discussed and illustrated in Section 4.2 was used to evaluate several different substrates. This section of the report discusses the experimental findings of probing ten substrates of various sizes and complexity. Probing occurred primarily with thick film substrates; however, some experimental work was directed at probing an array of thin film circuits.

The first substrate probed following the two discussed in the previous section was a single layer thick film substrate which had 24 nonconnected metalization runs. Eight different metalizations were probed and the data analyzed to completely evaluate the technique and the experimental parameters. Several of the probed metalizations on the substrate were connected to the machine ground reference. One metalization was connected through a 4.7-megohm resistor to ground, and one metalization was connected through a 158-picofarad ceramic capacitor to ground. Three metalizations were connected directly to ground. The remaining metalizations were left floating. The probe was set to scan each of the metalizations in a defined sequence. Figure 4.3-1 shows the relationship of the metalizations to one another.

A chart recorder was attached to the output of the video amplifier, and the voltage level of the probed metalizations was recorded. Figure 4.3-2 shows a section of the chart recording giving the readings for each of the metalizations probed. Different charging voltages, times, and beam currents were used to probe this metalization pattern. The charging rate was rapid in all cases, occurring faster than it could be easily controlled with the electron microscope. The 4.7 megohms to ground and 158 picofarads to ground responded much the same as the direct connections to ground. Considerable time and effort were spent on this basic substrate to evaluate the probing parameters. A charging voltage (acceleration) of 12 to 18 keV provided a lasting charge that was observable at an accelerating voltage of 4.5 keV. The strip chart recorder indicated a change in the metalization voltage

after successive probing at accelerating voltages below 3.5 keV. This phenomenon is discussed in the technique improvement and optimization phases, Section 5.0.

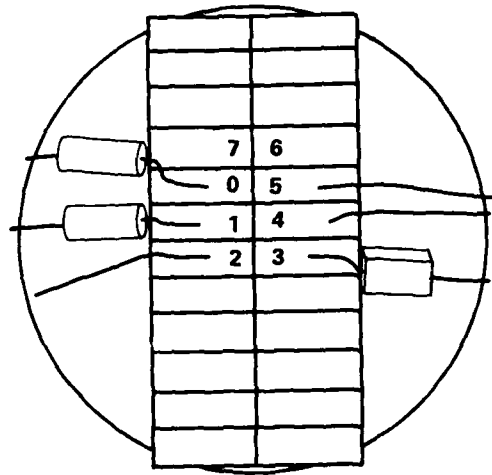

- | | | | |
|---|------------------|---|---------------|
| 0 | REFERENCE 4.7 MΩ | 4 | GND |
| 1 | 4.7 MΩ RESISTOR | 5 | GND |
| 2 | GND | 6 | NO CONNECTION |
| 3 | 158 PF CAPACITOR | 7 | NO CONNECTION |

Figure 4.3-1. Relationship of Metalizations Analyzed to Each Other

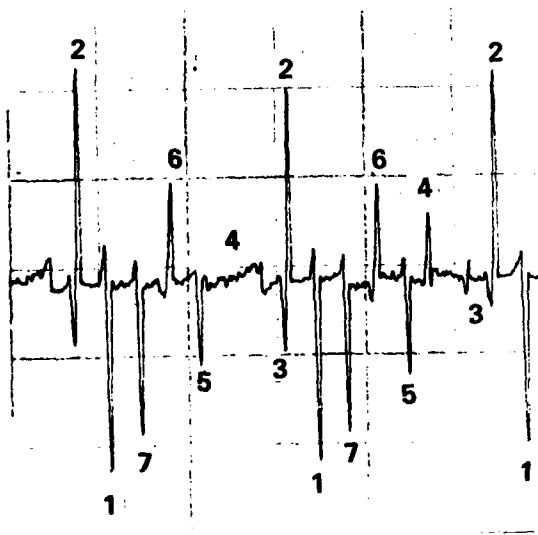

Figure 4.3-2. Probed Substrate Point 2 Charged, Points 1 through 7 Scanned and Analyzed

The second and third substrates probed using this technique were single layer thick film substrates as shown in Figure 4.3-3.

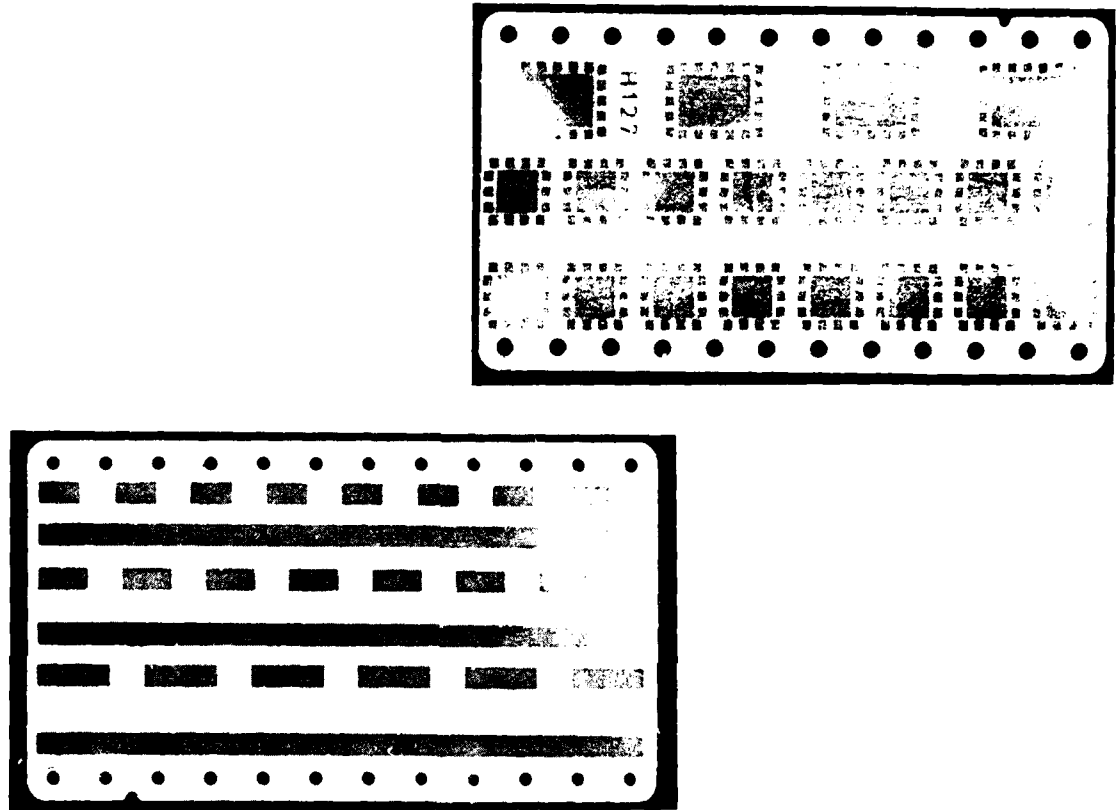

Figure 4.3-3. Two Substrates Probed with Electron Beam

Testing of substrate 001 indicated a shorted condition of two adjoining pad areas. This shorted condition was discovered as a result of the electron probing effort and was not found visually. Further evaluation with direct contact probing and high magnification optical study confirmed the electron probe findings. Several substrates of the 001 and 002 configurations were probed. The 002 substrate provided valuable data on the effect of adjoining charged metalizations on the other probe points under study. It was found in substrate 002 that charging to high (20 keV, many seconds) levels would retard secondary electron detection if the metalization that was highly charged was between the detector and the probed point.

The first multilayer substrate investigation was performed using substrate 005. Figures 4.3-4 and 4.3-5 show the substrate metalization and a secondary electron image of the metalization after being charged or probed with the electron beam. Figure 4.3-5 provides an optimized image of the probed substrate. The metalization was charged properly and

the image contrast and brightness throughout the detection and amplification path were carefully controlled. This same substrate was evaluated in an adjacent metalization path, as shown in Figure 4.3-6. The sharp contrast and bright metalization path are a result of careful control of the probing parameters.



Figure 4.3-4. Substrate 005 Ground or Reference Energy State



Figure 4.3-5. Substrate 005 Metalization Charged or Probed to Indicate Continuity

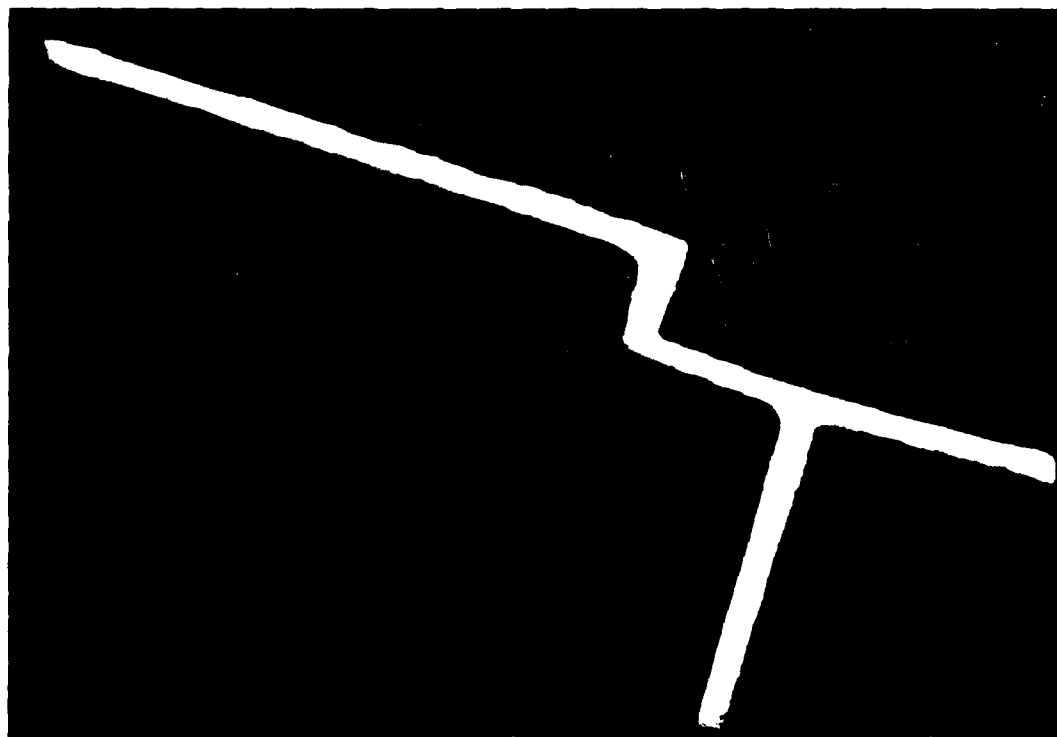
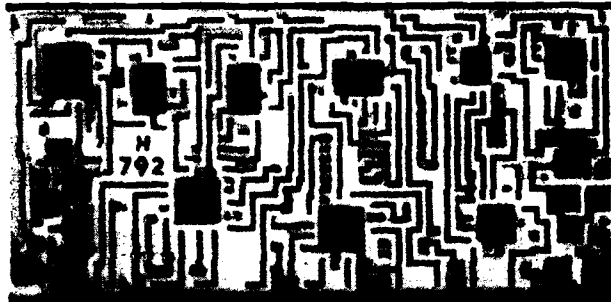

Figure 4.3-6. Charged Metalization of Multi Layer Substrate

The probing of multilayer substrates was further evaluated by the testing of substrate H792, as indicated in Figure 4.3-7. Over 200 probe points were identified and probed using the electron beam prober. The control and sensing of continuity was accomplished on several substrates. The surface cleanliness of the substrates and the probing parameters that provide optimum results were varied to indicate a range of tolerances. The repeatability of the technique was found to be poor in many substrates evaluated, which indicated a significant deviation from the theoretical.



a. Overall View of Substrate

b. Substrate Probe Points

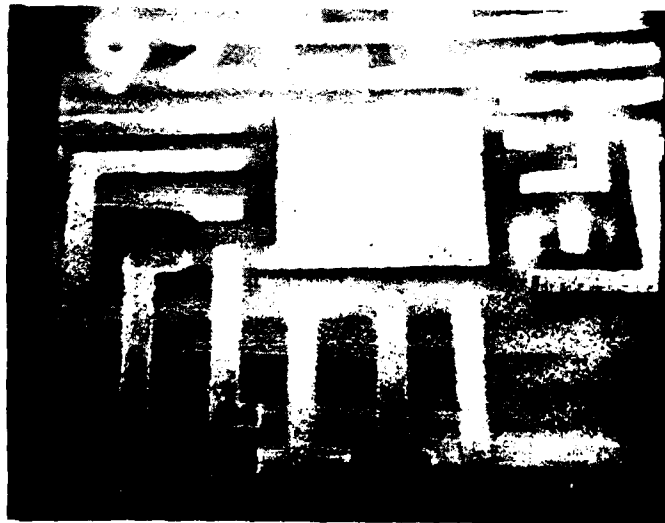

c. Probed Substrate

Figure 4.3-7. Substrate H792

The probing technique was also evaluated by the probing of various other substrates as indicated in Figure 4.3-8. Multilayer substrates with resistors and other significant patterns where surface topography would have an effect on the results of the probed points were evaluated in these substrates.

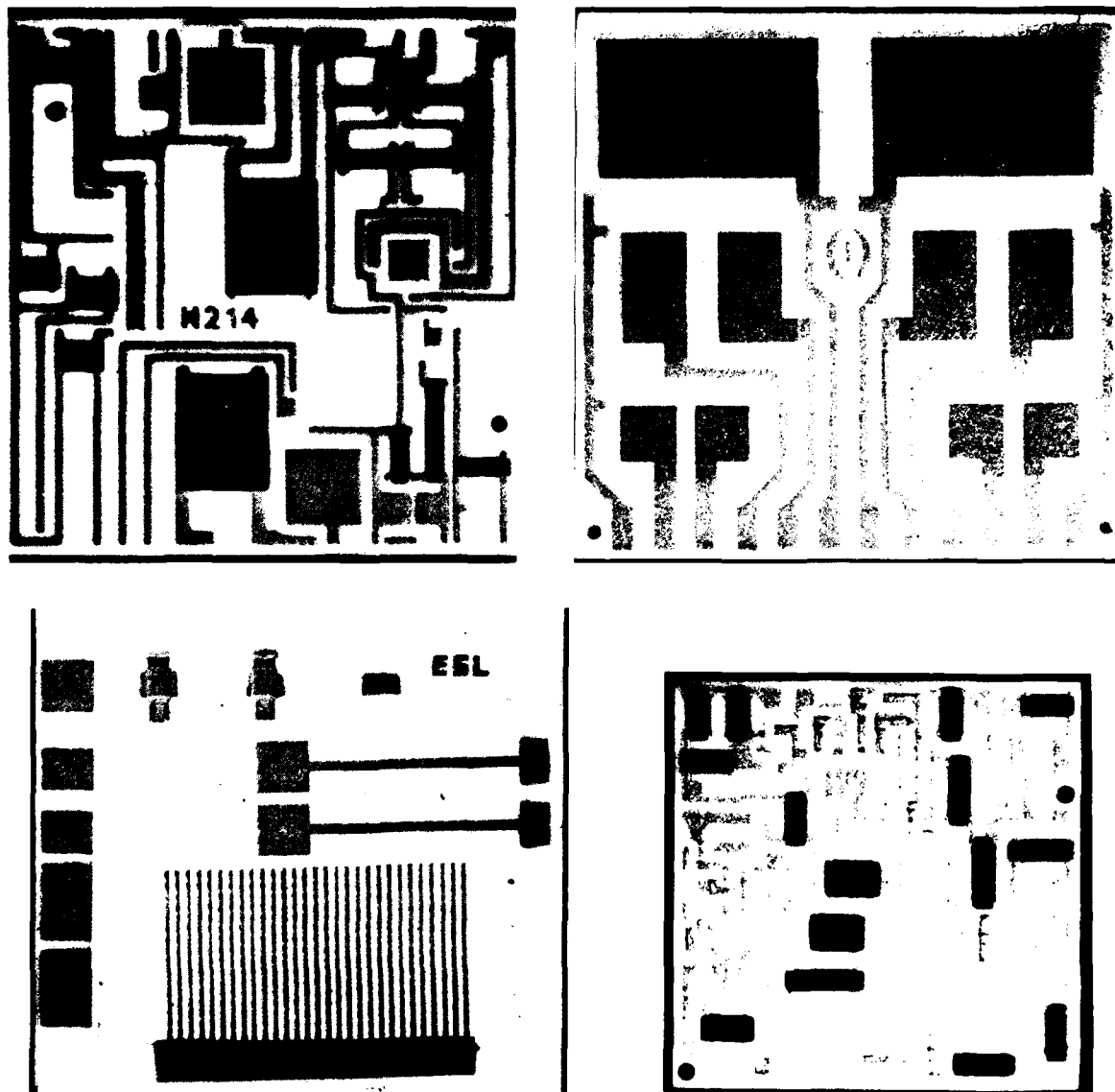

Figure 4.3-8. Multilayer Substrates for Evaluation of Surface Topography on Probing Techniques

A thin film substrate as indicated in Figure 4.3-9 was evaluated using the electron beam probing technique. It was not possible to achieve a consistent charged-up region for evaluation. It was hypothesized that

the cross-sectional area of the thin film material was too small to allow for generation of excess secondary electrons. This is believed to have occurred because the primary beam would penetrate through the several hundred angstroms of material and into the substrate. No "charged" regions of the thin film substrate could be accomplished. If probe points were configured with thicker metalizations, perhaps by plating, it is believed that the technique would apply.

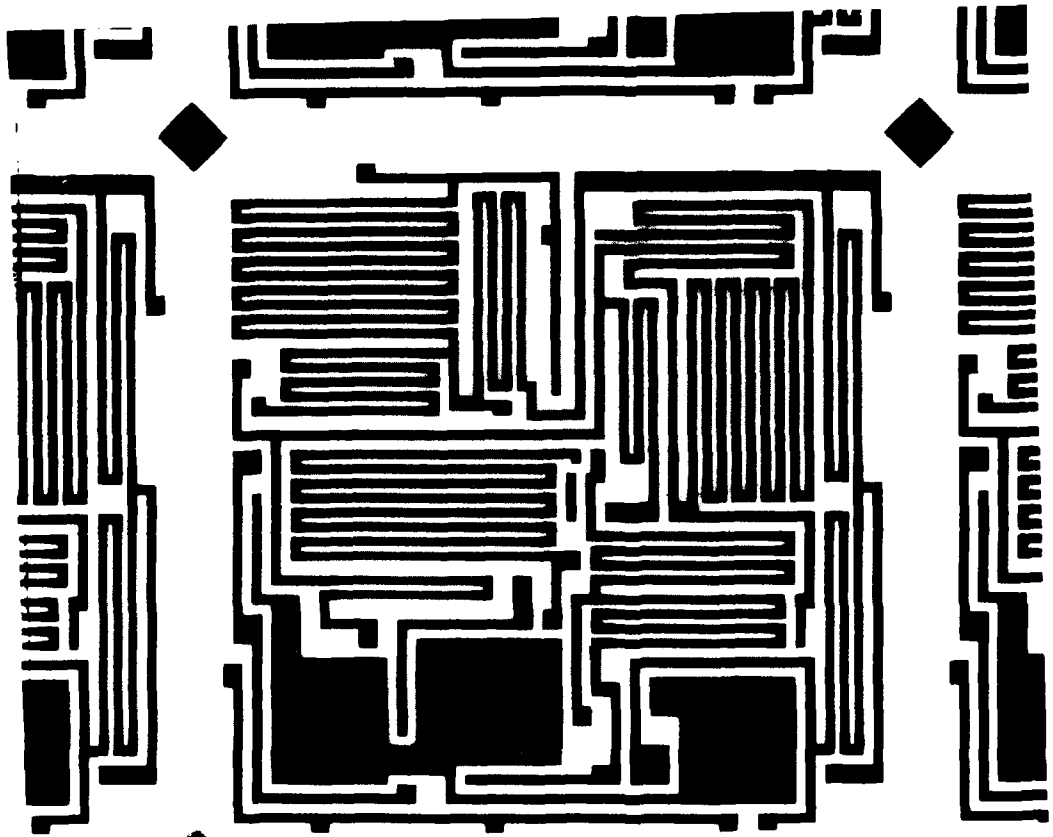

Figure 4.3-9. Thin Film Substrate

A multilayer substrate as shown in Figure 4.3-10 was examined using the probing technique. The complexity and multilayer characteristics were evaluated using mechanical probing for continuity and X-ray analysis for a more complete layout evaluation. Figures 4.3-10 and 4.3-11 show this relationship. Probing as illustrated in Figure 4.3-12 was accomplished on the multilayer substrate. The substrate was successfully probed using the noncontact probing technique. A unique phenomenon was discovered, in which the buried metalization would result in a "charged" insulator over the metalization and would therefore generate a signal. The effect is developed in more detail in technique improvement and optimization, Section 5.0.

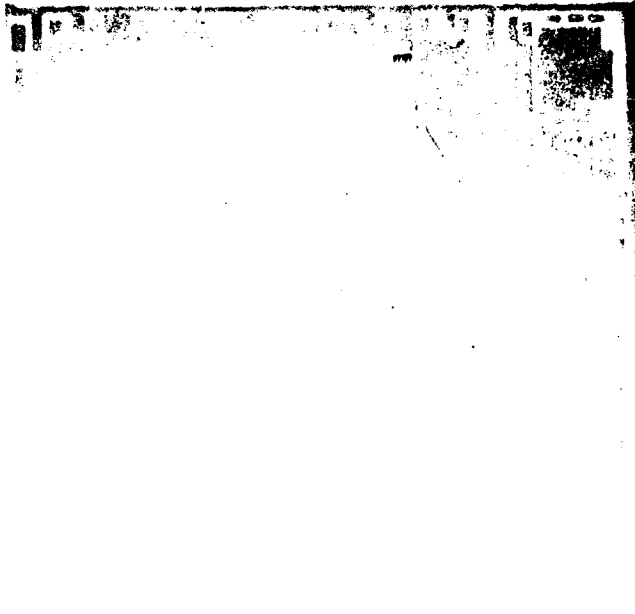

Figure 4.3-10. Overall Substrate

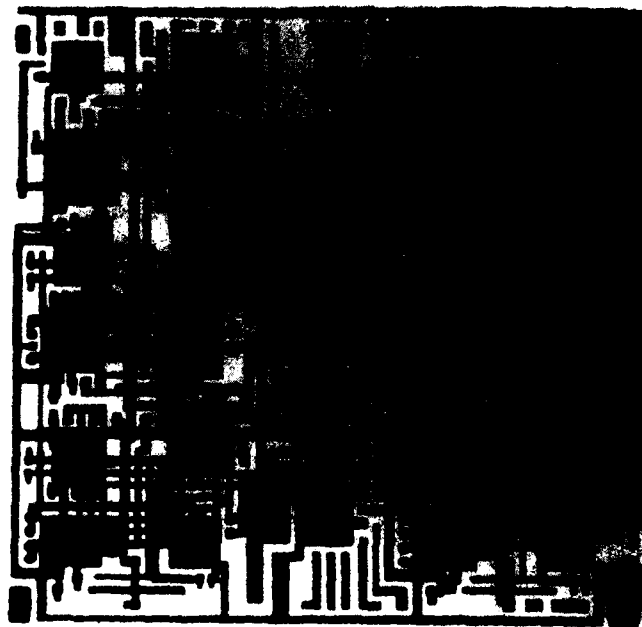

Figure 4.3-11. X-Ray-Generated Substrate Image

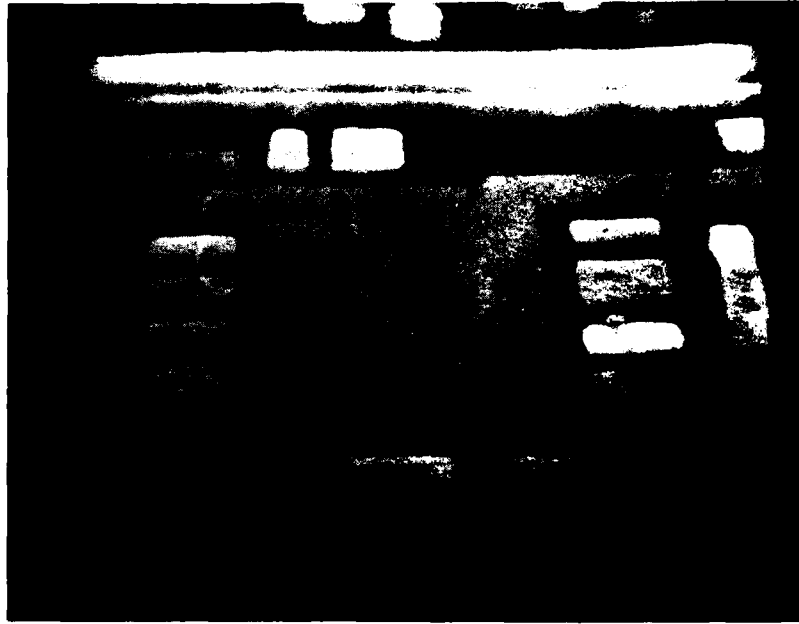

Figure 4.3-12. Secondary Electron Image of Probed Substrate

5.0 TECHNIQUE IMPROVEMENT AND OPTIMIZATION

The probing of metalization patterns during the test demonstration phase of the effort indicated several test parameters that must be carefully controlled. The surface conductivity is the most important of the properties, with surface contaminants having the largest influence on the ability to probe a substrate. As was indicated in Section 4.3, electrical fields close to the probed points can deflect the beam or the resulting signal. This results in improper probing of the substrate and in data being derived from inconsistent sources. The careful control of charging levels is essential, so that excessively high voltages do not occur on the substrate.

The test method in which a probed substrate is discharged using electrons was the most significant of the test technique improvement and optimization phase. The metalization pattern under test was charged to a predetermined level for continuity testing. The level of charge was sensed with the electron beam. When different accelerating voltages were used for the testing technique, an optimum voltage and probing time were determined. The test technique was improved by changing the accelerating voltage of the sensing beam from about 5000 to around 3500 volts. In the probing process of a set of seven points, as illustrated in Figure 4.3-2, the same points were scanned or probed with the beam several times in a predetermined sequence. The recorded values of each probed point were examined and compared. The level of charge varied from one probe to the next so that intermediate levels of the charged state could be sensed and identified. This comparison of different levels and values of surface potential was used to improve the testing sequence. The charge change from one probe to the next identified the interconnections of the metalization pattern. When the electron beam was directed at a metalization, a net increase or decrease in charge and therefore surface potential would occur. By sequencing through a set of probe points, the increase or decrease in the charge could be sensed (the secondary electron emission coefficient being greater than or less than one). If open or shorted conditions appeared, a corresponding change would occur in the results of the probed sequence. This technique improvement is best understood if a probing sequence such as that illustrated in Figure 5.0-1 is evaluated. The initial run through the seven points produces the probe levels indicated in Figure 5.0-2. It can be seen that the levels are additive and can therefore indicate the connection pattern and past history of a set of selected points.

An additional test technique improvement was related to the imaging of metalization runs under the dielectric. The injection of charge into an exposed metalization pattern produced a higher electrical potential on the

metalization. It was observed that buried metalizations could be imaged through the dielectric by localized charge injection in the dielectric. The dielectric above the charged metalization was enhanced with excess carriers and was found to provide valuable information about the state of the metalization under the dielectric. Figure 5.0-3 and 5.0-4 illustrate the buried metalization path that was imaged through the dielectric.

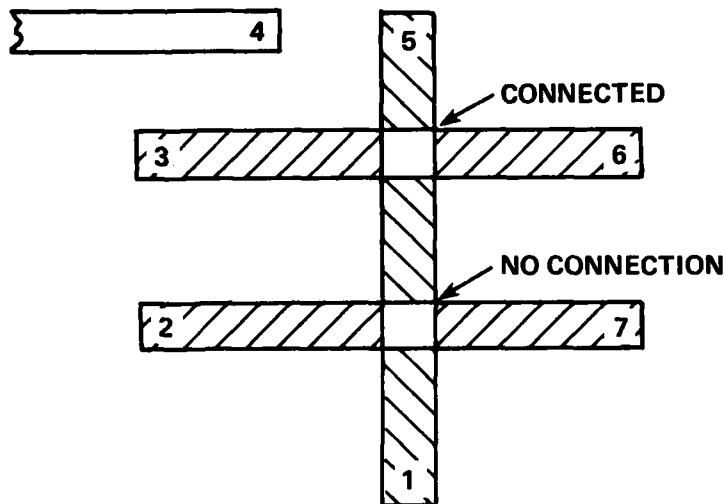

Figure 5.0-1. Test Technique Improvement by Level Differentiations

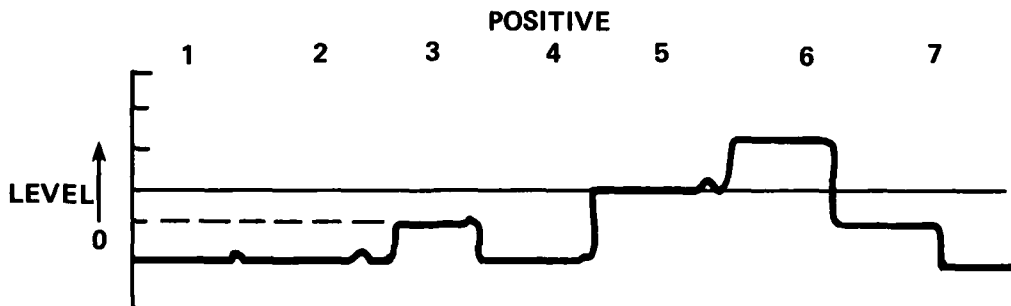

Figure 5.0-2. Test Output of Testing Metalization Pattern

Figure 5.0-3. Example of Buried metalization Path Imaged through the Dielectric

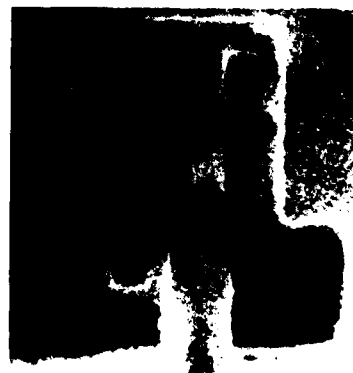



Figure 5.0-4. Another example of Charged Buried Metalization Path Imaged through the Dielectric

The charging and resolution of different levels of charge can be detected in Figure 5.0-3 but are more readily detected in Figure 4.3-12. Figure 4.3-12 shows two gray levels which are a result of the different periods of time that the electron beam was striking the probe positions. Further analysis of multiple levels of charge for detection of secondary electrons as functions of time, accelerating voltage, and beam current could best be made with an energy analyzer/filter.

6.0 CONCLUSIONS AND RECOMMENDATIONS

The probing of multilayer thick film substrates using the noncontact method of measurement with an electron beam was successful. The technical feasibility and the major methods of testing were evaluated. The variability of the technique and the stringent requirements that must be imposed in a test tool to ensure a high level of confidence of test results indicate further investigation. As shown in this report, there is a promise of a high-speed universal testing tool that can readily test many different types of thick film substrates. Factors of concern for a manufacturing environment, where speed and accuracy are of greatest importance, must be addressed in future studies.

REFERENCES

1. Bruining, H. "Physics and Applications of Secondary Electron Emission," Pergamon Press, N.Y., 1954.
2. Crawford C.K., "Charge Neutralization Using Very Low Energy Ions," Scanning Electron Microscopy/1979/II, IIT Research Institute, Chicago, IL, pp. 32-66.
3. Columbe, M.J., "System for Charge Neutralization," U.S. Patent No. 2,890,342, (1959).
4. Morin, P., Pitavel, M. and Vicario, E., "Direct Observation of Insulators with a Scanning Electron Microscope," J. Phys. E. 9, 1976, pp 1017-1020.
5. Wolfgang, E., Lindner, R., Fazekas, P. and Feuerbaum, H. "Electron-Beam Testing of VLSI Circuits," IEEE Transactions of Electron Devices, Vol. ED-26 No. 4, April 1979, pp 549-559.
6. Wells, O. and Bremer, C. "Voltage Measurement in the Scanning Electron Microscope," J. Scientific Instruments, (J. Physics E) Vol 1, 1968, pp 902-906.
7. Kudirka, P. and Crawford C., "Potential Measurement and Stabilization of an Isolated Target Using Electron Beams." Solid-State Electronics, Vol. 15, 1972, pp 987-992.

DISTRIBUTION LIST

RCA Borton Landing Road Moorestown, NJ 08057 Attn: John Barnes	1	ITT Avionics Division 390 Washington Avenue Nutley, NJ 07110 Attn: Steve Reiss	1
Harris Corporation P.O. Box 37 Melbourne, FL Attn: M.F. Belgin	1	E-Systems ECI Division P.O. Box 12248 St. Petersburg, FL 33733 Attn: Carl Pechinpaugh	1
Raytheon Company Hartwell Road Bedford, MA 01730 Attn: J.A. Cicco	1	GTE Sylvania 77 A Street Needham, MA Attn: A. Avakian	1
Northrop Corporation Electronics Division 2301 West 120th Street Hawthorne, CA 92050 Attn: P.H. Eisenberg	1	RCA Corporation Automated Systems P.O. Box 588 Burlington, MA 01803 Attn: Duane Belden	1
Westinghouse Defense and Electronics Systems Center P.O. Box 746, Mail Stop V-14 Baltimore, MD 21203 Attn: Al Hamil	1	Magnavox G&I 1313 Production Ft. Wayne, IN 46808 Attn: Gene Bonfiglio	1
General Dynamics Pomona Division MZ 4-26, P.O. Box 2507 Pomona, CA 91766 Attn: John Kanz	1	TRW DSSG One Space Park Redondo Beach, CA 90278 Attn: Hugh Brady	1
General Dynamics Electronics P.O. Box 81127-M/Z 7-08 San Diego, CA 92138 Attn: Merrill Palmer	1	Sperry Univac Univac Park, P.O. Box 3525 St. Paul, MN 55165 Attn: C.J. Bukkila	1
Teledyne Microelectronics 12964 Panama Street Los Angeles, CA 90066 Attn: Ralph Redemski	1	E-Systems ECI Division P.O. Box 81127, M/S 7-08 St. Petersburg, FL Attn: Jim Cerny	1

Naval Avionics Center 21st and Arlington Indianapolis, IN 46218 Attn: Michael Cowart	1	NSA Fort Meade, MD Attn: George Smith	1
Electronic Industries Assn. 2001 Eye Street NW Washington, DC 20006 Attn: Jean Caffiaux	1	Naval Ocean Systems Center Code 9253 San Diego, CA 92152 Attn: R.F. Unger	1
Eastman Kodak Corp. 901 Elmgrove Road Dept 488, LP KAD Rochester, NY 14650 Attn: Joseph Gantman	1	Warner Robins ALC/MAIES Bldg. 640 Robins AFB, GA 31098 Attn: Jerry Watts	1
McDonnell Douglas Electronics 2600 N. Third St. Charles, MO 63301 Attn: Larry Hayes	1	General Electric Company Electronics Park 3-314 Syracuse, NY 13201 Attn: Richard Clark	1
Lockheed Missiles & Space 1332 Vancouver Avenue Burlingame, CA 94010 Attn: Juscen, B.F.	1	Defense Documentation Center Cameron Station Alexandria, VA 22314	2
Honeywell 13355 U.S. Highway 19 St. Petersburg, FL Attn: A.W. Kelley	1	Director Army Materials and Mechanics Research Center Watertown, MA 02172 Attn: DRXMR-PT	L
AFML/LTE Wright Patterson AFB Ohio 45433 Attn: Donald Knapke	1	Director U.S. Army Industrial Base Engineering Activity Rock Island Arsenal Rock Island, IL 61201 Attn: DRXIB-MT	2
Rockwell International 2230 East Imperial Blvd El Segundo, CA 90245 Attn: Dave Mitchell	1	Commander U.S. Army Materiel Development and Readiness Command Alexandria, VA 22333 Attn: DRCMT	1
General Electric French Road, Mail Drop 304 Utica, NY 13503 Attn: Rodman Mogle	1	Commander Frankford Arsenal Bridge and Tacony Streets Philadelphia, PA 19137 Attn: SARFA-MTT	1
NESO Code 33130, Bldg. 463 North Island San Diego, CA 92135 Attn: Rose Shuttleworth	1		

Commander
U.S. Army Tank and Automotive
R&D Command
Warren, MI 48090
Attn: DRDTA-R

1

Commander
Picatinny Arsenal
Dover, NJ 07801
Attn: SARPA-MT-C

1

Commander
U.S. Army Aviation Systems
R&D Command
12th and Spruce Streets
St. Louis, MO 63166
Attn: DRDAV-EXT

1

Commander
U.S. Army Electronics
R&D Command
Ft. Monmouth, NJ
Attn: DELET-TL-IC

1

Commander
Naval Material Command
Code 042
CP#5 Room 722
Washington, DC 20360

1

Commander
U.S. Air Force Materials
Laboratory
Wright Patterson AFB
Dayton, Ohio 45433
Attn: AFML/LT

L