

AD-A087 217 ARMY ARMAMENT RESEARCH AND DEVELOPMENT COMMAND WATER--ETC F/6 14/2  
DEVELOPMENT AND OPERATION OF 8 INCH LABORATORY ESR FURNACE AT W--ETC(U)  
UNCLASSIFIED MAR 80 W SULLIVAN, V COLANGELO SBIE-AD-E440 072 NL  
ARLCEB-TR-80007

| OK |  
50  
AD87217

END  
DATE  
FILMED  
9-80  
DTIC

**LEVEL III**

AD-E 490 072  
**12** B.S.

AD

ADA 087217

TECHNICAL REPORT ARLCB-TR-80007

DEVELOPMENT AND OPERATION OF 8 INCH  
LABORATORY ESR FURNACE AT WATERVLIET ARSENAL

W. Sullivan  
V. Colangelo

March 1980

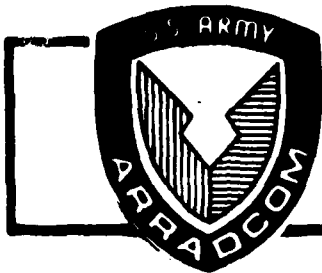

US ARMY ARMAMENT RESEARCH AND DEVELOPMENT COMMAND  
LARGE CALIBER WEAPON SYSTEMS LABORATORY  
BENÉ WEAPONS LABORATORY  
WATERVLIET, N. Y. 12189

AMCMS No. 3297.06.7550

PRON No. M1-5-A1731

DTIC  
ELECTE  
JUL 29 1980  
S D D

APPROVED FOR PUBLIC RELEASE; DISTRIBUTION UNLIMITED

DDC FILE COPY

80 7 2 030

#### DISCLAIMER

The findings in this report are not to be construed as an official Department of the Army position unless so designated by other authorized documents.

The use of trade name(s) and/or manufacturer(s) does not constitute an official indorsement or approval.

#### DISPOSITION

Destroy this report when it is no longer needed. Do not return it to the originator.

UNCLASSIFIED

SECURITY CLASSIFICATION OF THIS PAGE (When Data Entered)

REPORT DOCUMENTATION PAGE		READ INSTRUCTIONS BEFORE COMPLETING FORM
1. REPORT NUMBER ARLCB-TR-80007	2. GOVT ACCESSION NO. AD-A087217	3. RECIPIENT'S CATALOG NUMBER
4. TITLE (and Subtitle) Development and Operation of 8 Inch Laboratory ESR Furnace at Watervliet Arsenal		5. TYPE OF REPORT & PERIOD COVERED
7. AUTHOR(s) W. Sullivan V. Colangelo		6. PERFORMING ORG. REPORT NUMBER
9. PERFORMING ORGANIZATION NAME AND ADDRESS US Army Armament Research and Development Command Benet Weapons Laboratory, DRDAR-LCB-TL Watervliet, N.Y. 12189		8. CONTRACT OR GRANT NUMBER(s)
11. CONTROLLING OFFICE NAME AND ADDRESS US Army Armament Research and Development Command Large Caliber Weapon System Laboratory Dover, New Jersey 07801		10. PROGRAM ELEMENT, PROJECT, TASK AREA & WORK UNIT NUMBERS AMCMS No. 3297.06.7550 DA Project PRON No. M1-5-A1731
14. MONITORING AGENCY NAME & ADDRESS (if different from Controlling Office)		12. REPORT DATE March 1980
		13. NUMBER OF PAGES 31
		15. SECURITY CLASS. (of this report) UNCLASSIFIED
		15a. DECLASSIFICATION/DOWNGRADING SCHEDULE
16. DISTRIBUTION STATEMENT (of this Report)  Approved for public release; distribution unlimited		
17. DISTRIBUTION STATEMENT (of the abstract entered in Block 20, if different from Report)		
18. SUPPLEMENTARY NOTES		
19. KEY WORDS (Continue on reverse side if necessary and identify by block number)  ESR Melting                      Hollow Steel Ingots Steel Castings                  Servo Systems Slag                                  Furnace (ESR)		
20. ABSTRACT (Continue on reverse side if necessary and identify by block number) This report is an evaluation of a contractor furnace (ESR) for use in laboratory experiments in melting solid and hollow ingots. The report describes the condition of the furnace as installed, the problems encountered together with the design changes made in-house to correct the existing deficiencies. The report also indicates the technical areas that must be explored to fully develop a hollow ingot technology.		

## CONTENTS

	<u>Page</u>
INTRODUCTION	1
ESR PROCESS	1
FURNACE EVALUATION	4
DESIGN CHANGES	6
MELTING ACCOMPLISHMENTS	7
Solid Ingots	7
Hollow Ingot Program	10
Hollow Ingot Data	14
Ingot Evaluation	14
Chemistry	18
Mechanical Properties and Melt History	18
CURRENT STATUS AND RECOMMENDATIONS	21
APPENDIX	23

## ILLUSTRATIONS

### Figure

- |   |   |
|---|---|
| 1. Solid ESR Furnace  | 3 |
| 2. Frame of ESR Furnace Showing Hydraulic Cylinders<br>and Ingot Support System | 5 |
| 3. Cutting Diagram Indicating Specimen Identification                           | 9 |

Accession For	
NTIS GRA&I	<input checked="" type="checkbox"/>
DDC TAB	<input type="checkbox"/>
Unannounced	<input type="checkbox"/>
Justification	
By _____	
Distribution/	
Availability Codes	
Dist.	Avail and/or special
A	

	<u>Page</u>
4. Melting Parameters for Various Solid 8 Inch Ingots	11
5. Schematic Diagram Illustrating Typical Set-Up for ESR Hollows with Solid Electrodes and Bottom Mandrel	12
6. Sectioned Solid and Hollow Ingots with Corres- ponding Slag Caps - Solid on Left and Hollow Cap on Right of Ingot	15
7. Cross and Longitudinal Sections from Top Third of 8 Inch Hollow Ingot	16
8. Cross and Longitudinal Sections from Middle of 8 Inch Ingot	17
9. Melt Parameters for Various Hollow Ingots	19

#### TABLES

I Tensile, Impact and Hardness Properties of 4340 Electrode VS. ESR Melted Solid Ingot	27
II Chemistry of 4340 Electrode VS. Solid Ingot	28
III Chemistry of 4340 Electrode VS. ESR Hollow Ingot	28
IV Tensile, Impact and Hardness Properties of 4340 Electrode VS. ESR Hollow Ingot	29

## 1. INTRODUCTION

In August 1974, a laboratory - sized Electroslag Refining furnace (ESR) was purchased from an outside contractor and installed at Watervliet Arsenal for use in alloy development programs and hollow ingot experiments.

The subject furnace was designed to melt solid ingots up to 8" in diameter and hollow ingots ranging from 8" OD x 2" ID to 8" OD to 4" ID. In both cases, the total ingot height capability is 48 inches.

The following report details the condition of the furnace as it was installed, the problems encountered together with the design changes which were instituted. The report also indicates the areas which must be explored in order to fully develop a hollow ingot technology<sup>(1)</sup>.

## 2. ESR Process:

Electroslag refining is a secondary refining process. It is used for further purification of material that has been previously melted. The primary product prior to ESR melting may be cast or wrought or composed of scrap. In this configuration it is known as an electrode and its shape and dimension are determined by the ESR furnace in

---

1. Colangelo, V. J., Development of Prototype Production, Benet Weapons Laboratory, 2 July 1970.

which it is to be subsequently melted. The furnace contains a water cooled base and water jacketed mold. The bottom tip of the electrode is immersed in a slag bath which is resistance heated by electric current passing between the electrode and a cooled base plate (see Figure 1). The magnitude of the electric current is such that it causes the temperature of the slag bath to rise above the melting point of the metal. Once this condition is reached, droplets of metal melt off the electrode and fall through the slag to form an ingot on the cool baseplate. The ingot then acts as a secondary electrode and progressively builds upward by a progressive solidification process.

As the molten slag rises because of displacement, it meets the cooled mold wall. Thus, a thin layer solidifies on the mold surface forming a thin shell that remains intact after the steel has been solidified. This forms a smooth mold lining that contributes to an excellent ingot surface<sup>(2)</sup>.

Refining takes place by two mechanisms. The first is the reaction of the slag and the metal. This is accomplished in three stages:

(1) During formation of the metal droplets at the tip of the electrodes;

---

2. Duckworth, W.E. and Hoyle, G., Electro-Slag Refining, 1969 - Great Britain - by the Chaucer Press Ltd.

# SOLID ESR

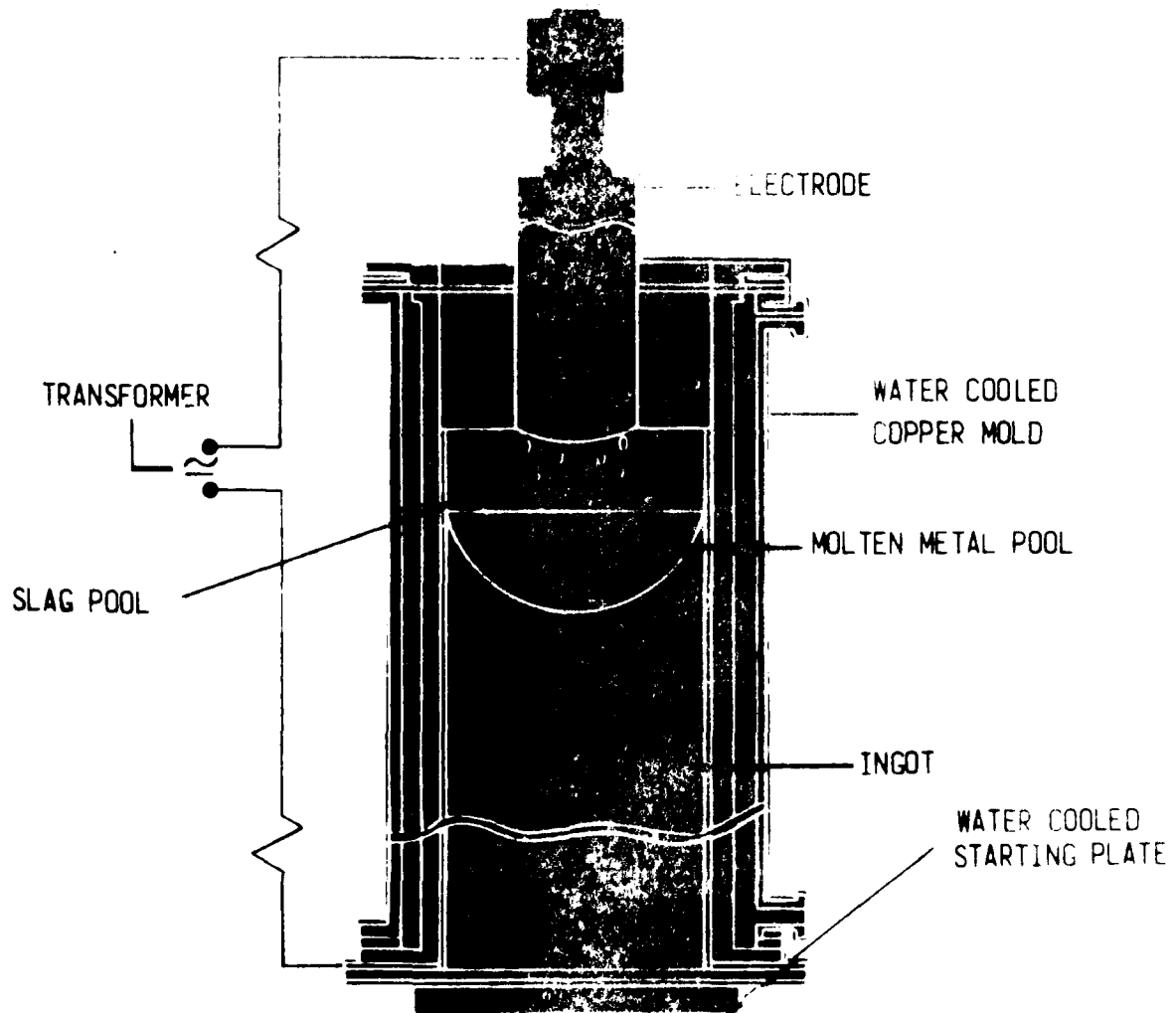

Figure 1. ESR Furnace

(2) During the fall of the metal droplets through the slag, and,

(3) During the contact time of the slag and the surface of the molten metal pool.

The second mechanism is the benefit derived from the process of progressive solidification.

### 3. Furnace Evaluation:

Upon installation, the furnace displayed operational deficiencies in two major areas. Both the crucible and the electrode drive mechanisms malfunctioned under varied operating conditions. The problem encountered in both cases was racking. This is basically a straining, wrenching or binding action caused on the framework when an uneven distribution of moment forces was distributed across it. This causes the system to transform from a rectangular structure with all axes perpendicular into a parallelogram.

The framework is comprised of the two main support guide posts and the cross members that support the crucible and the electrode. Referring to Figure 2, it is noted that the crucible and the electrode cross members are each driven by a hydraulic cylinder at one end only. This is the major reason for the racking problem.

The frictional forces on the crucible and the electrode cross members produced torsional forces that eventually

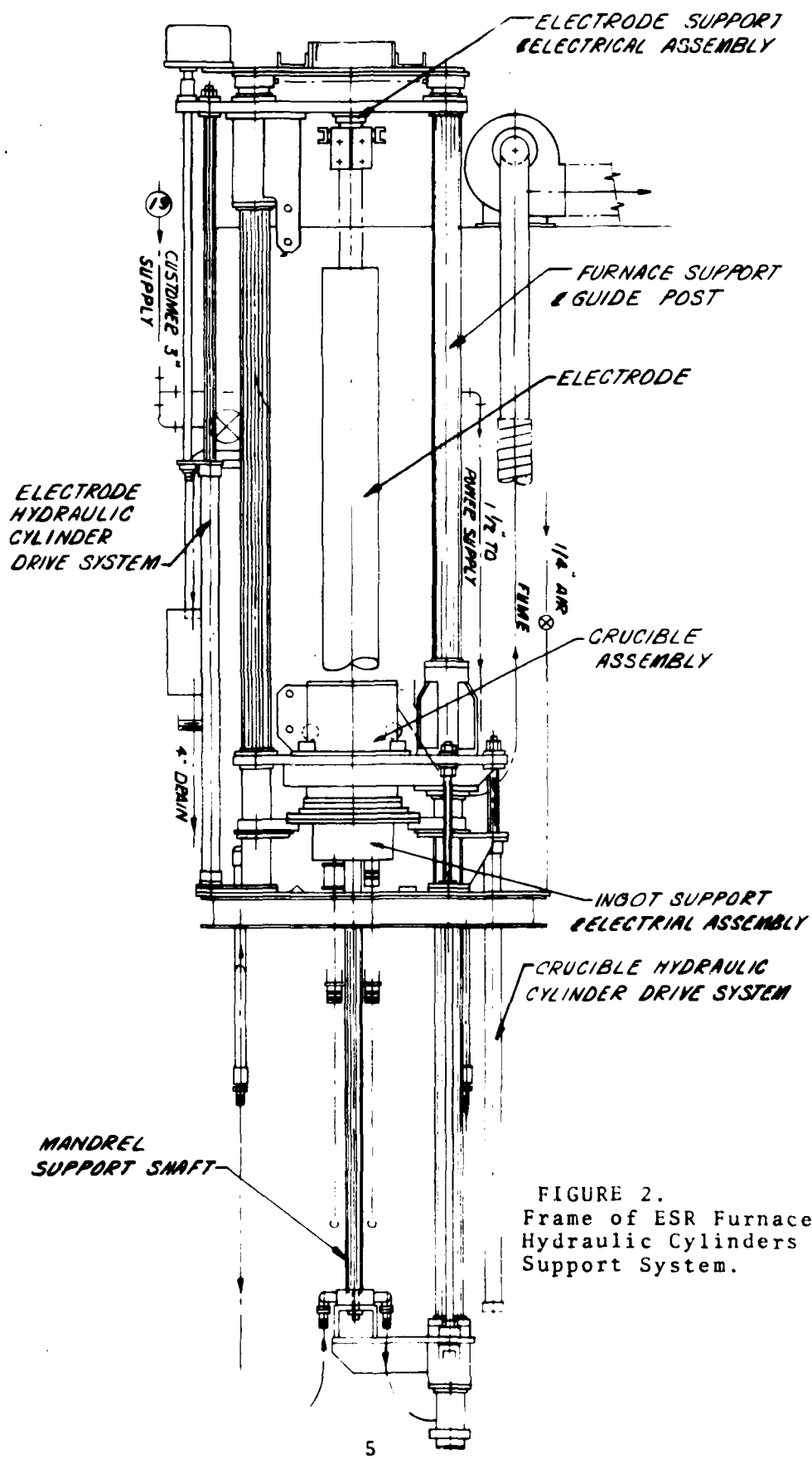

FIGURE 2.  
 Frame of ESR Furnace showing  
 Hydraulic Cylinders and Ingot  
 Support System.

rendered the furnace inoperable. Initially the problem only manifested itself in the hollow ingot mode. It resulted in aborted hollow ingot melts because the single hydraulic cylinder could not move the crucible and the mandrel. The molten metal would then freeze over the top of the mandrel.

The evolution of problems with the electrode drive mechanism was one of a gradual process. During the early stages of furnace operations manufacturing solids, no problems were revealed. However, through continuous use, the deterioration of the drive system eventually rendered the furnace inoperable in the hollow ingot mode and extremely difficult to operate in the solid ingot mode.

#### 4. Design Changes:

To eliminate the sticking crucible and mandrel problem, the furnace was completely dismantled and redesigned. The furnace was realigned because it was found to be as much as .090" out of straightness. In addition, all of the worn out insulating Nylatron bearings had to be replaced. But most important was the installation of a hydraulic crucible-mandrel drive cylinder on the left side of the furnace. This cylinder is identical to the one on the right side and was required to push equally on both sides of the crucible-mandrel raising platform, in order to eliminate the racking problem.

Other modifications were also made, e.g., remachined starter blocks to prevent slag run down. Additional rods were also installed on the left side of the furnace to pull the mandrel more uniformly.

To correct the electrode drive problem, the furnace was again dismantled and a second cylinder identical to the one already in place was installed. This helped to smooth out the motion of the electrode drive.

#### 5. Melting Accomplishments:

As was stated in the Introduction, the furnace was designed to produce both solid and hollow ingots. In both cases only one composition of slag was used, the constituents of which were as follows: 70% CaF<sub>2</sub>, 15% CaO and 15% Al<sub>2</sub>O<sub>3</sub>.

a. Solid Ingots: To initiate a functional system, it is necessary to establish operational procedures which will optimize the service for which it was intended. That was the purpose for the first series of ingots. Once the melting procedures were optimized, the furnace could be utilized for alloy development programs, and to evaluate the effects of ESR on medium carbon steels.

A melting program was instituted to compare the properties of material which was air melted to material which was ESR melted. An example is the data obtained from a 4340 six inch diameter electrode that was melted into an eight

inch diameter ingot. Tensile, impact and hardness properties were taken from both the electrode and the resultant ESR ingot.

Figure 3 shows the ingot coding. The data is presented in Table I. The test bars were taken in accordance with Standard E399 "Plane Strain Fracture Toughness of Metallic Materials" in the C-R direction (radial transverse). All test specimen blanks (coupons) were heat treated together. The outstanding difference noted between the commercial 4340 and the ESR melted 4340 is the marked increase in ductility (%El and %RA) and toughness (impact strength) while the Y.S., U.T.S. and hardness remained the same. As will be noted later, this same improvement can be seen when comparing a 4340 electrode to the ESR as-cast heat treated properties for a hollow ingot.

This improvement is believed to be due to the large reduction of the sulfur content, sulfide inclusions and other inclusions which are removed by the molten slag during the remelting process.

The chemistry of the 4340 electrode and the 8" diameter solid were evaluated to determine if any of the eight elements in 4340 changed during ESR melting. With respect to the ingot, the chemistry was also checked to see if there were any variations between the top and bottom of the ingot.

**EIGHT-INCH ESR SOLID INGOT  
USED FOR TEST PURPOSES**

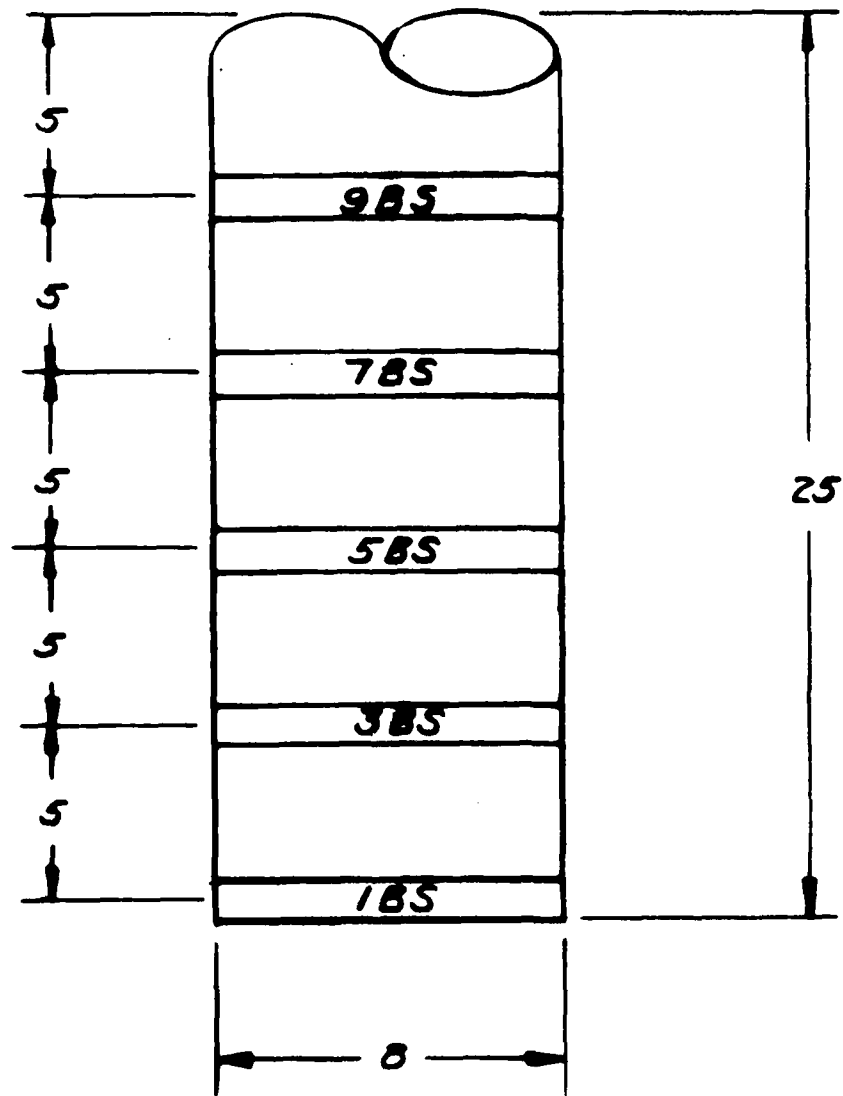

Figure 3. Cutting Diagram Indicating Specimen Identification

The most notable difference in the solid ingot was that the sulfur dropped from 0.022% in the electrode to 0.005 - 0.002% in the five checks made on the ingot. This data is given in Table II. All of the other seven elements varied insignificantly and were within the range of analysis techniques.

Figure 4 shows the typical melting parameters for solid ingots.

b. Hollow Ingot Program:

The furnace was designed to produce hollow ingots by the "hot piercing technique". In this system, a mandrel is supported from the bottom and driven upward during the melting as shown in Figure 5. It is essential to know the location of the liquid/solid interface.

Because of the absence of a liquid level detection system, the progress of the program was extremely curtailed. The tracking method consisted of visually observing the height of the liquid slag. The procedure was as follows: The slag was allowed to rise to a predetermined point in the crucible. Once this point was reached, the hydraulic drive system was turned on and the slag level in the crucible was then tracked manually. An essential step in the melting procedure was to quickly pour the molten slag into the crucible to initiate melting. This resulted in a crust

# 8" $\phi$ SOLID INGOT

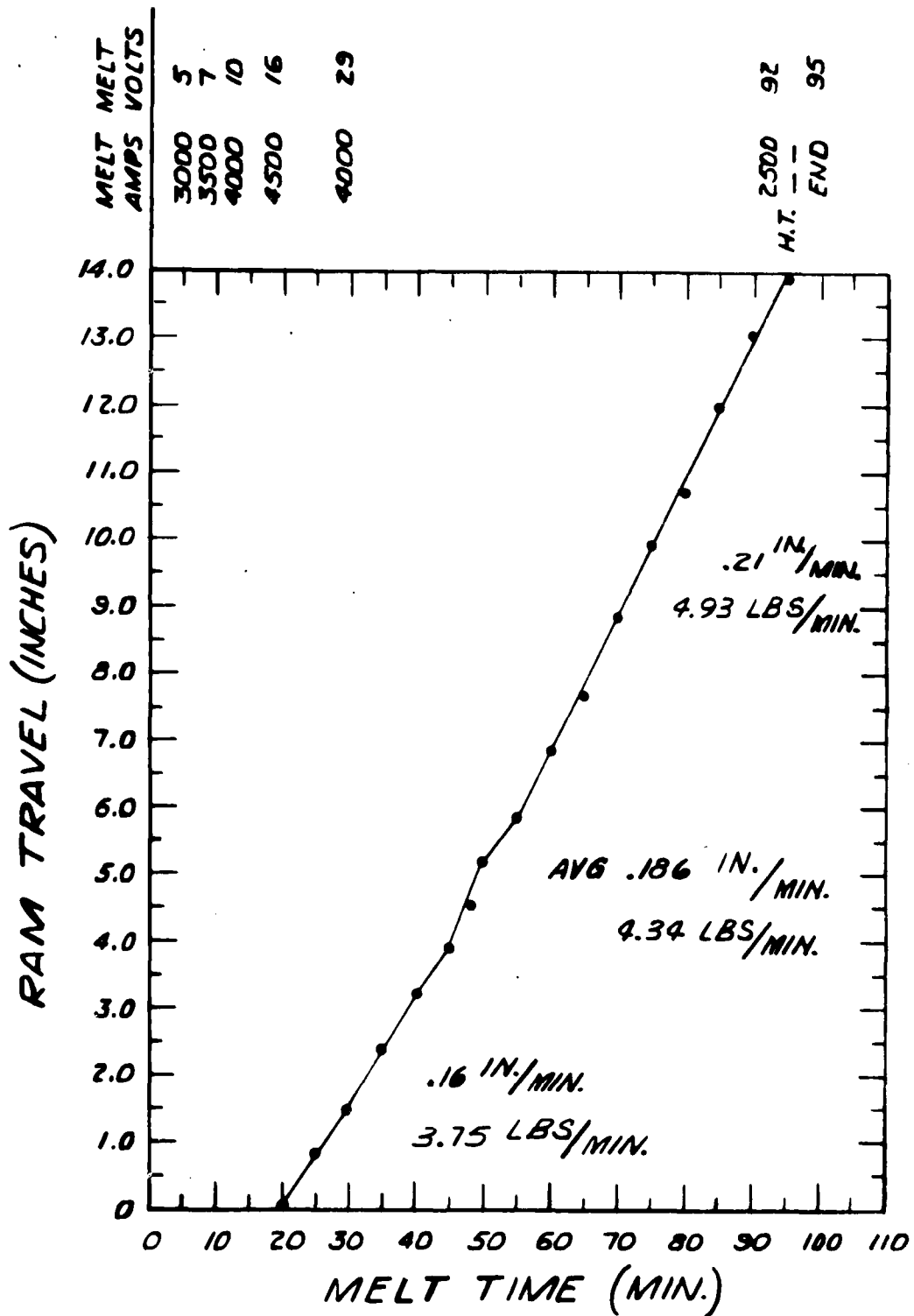

Figure 4. Melting Parameters for Various Solid 8 Inch Ingots

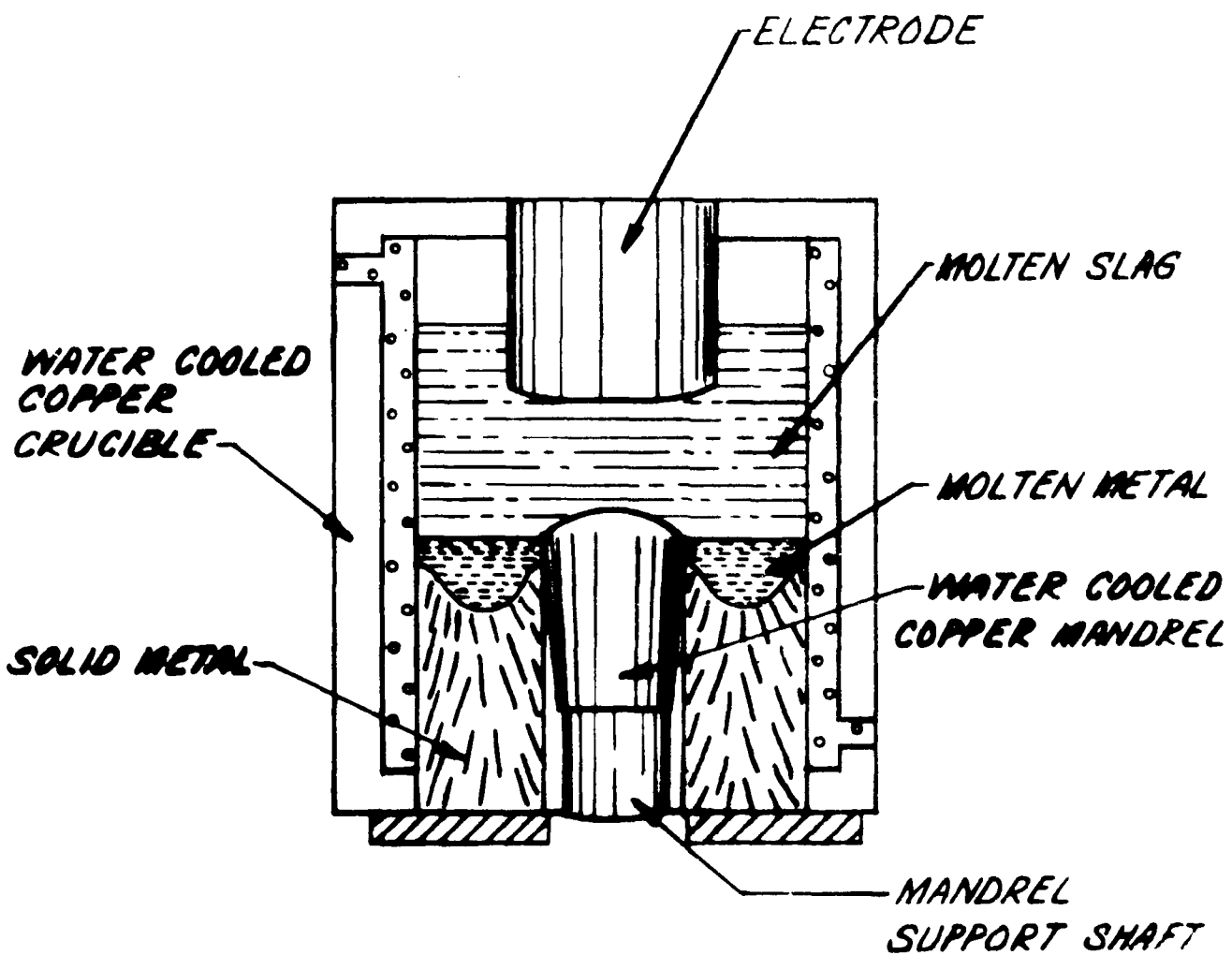

Figure 5. Schematic Diagram Illustrating Typical Set-up for Laser Hollows with Solid Electrodes and Bottom Mandrel

formation, due to the rapid cooling. This obviously eliminated the sighting procedure during the first crucial minutes. To compensate for this perturbation, a melt rate versus time period calibration had to be determined to set the mandrel in motion.

To control the mandrel speed by sight alone has many drawbacks. First, if the mandrel is moving too slowly in relation to the melt rate, the molten metal level rises above the mandrel shoulder. This then freezes and the mandrel is trapped within the hollow ingot. Conversely, if the mandrel speed is greater than the melt rate, a run out occurs which results in a pool of molten metal and slag underneath and around the furnace - a situation which is very hazardous to the operating personnel.

To further complicate the situation, the pool depth is not uniform with a constant power input. The reason for this is that during melting, the thermodynamic conditions do not remain constant. For instance, in the beginning of the melting there is a large surface area to volume ratio. The efficiency at this point is very low; but, as the melting progresses, the heat conducting surface area decreases and melting efficiency increases. This causes an increase in the pool depth. Monitoring the slag level in the crucible does not compensate for these variables.

The same problem also occurs when it is time to hot top. The power is purposely lowered to decrease the pool depth. Again, it is difficult to track the changing pool depth.

Presented in the Appendix are some examples in the form of diary excerpts of the problems which have been encountered during the hollow ingot program. At this juncture, it should be interjected that the tracking problems were not really sensed until after the racking situation was eliminated.

b.(1) Hollow Ingot Data:

There were many efforts to produce hollow ingots. However, all of them were interrupted due to the previous problems discussed. Of the total amount, the largest ones in height were 20", 15" and 13". The others were between 4 and 7 inches.

The longest ingot was selected for material evaluation.

b.(2) Ingot Evaluation, 20" Long Hollow:

The ingot was cut into three sections and then each section was cut longitudinally, as shown in Figure 6. These sections were also ground and etched with a 50 HCl - 50H<sub>2</sub>O solution at 150°F (See Figures 7 and 8). The length, angle, severity and size of the columnar grain structure depend on melting parameters such as pool depth, power input, slag type, slag temperature, solid OD-ID slag coating thickness, water temperature, angle on mandrel, melt rate, and many other intangible factors. This is especially true in the bottom of the ingot where the water cooled starter-block

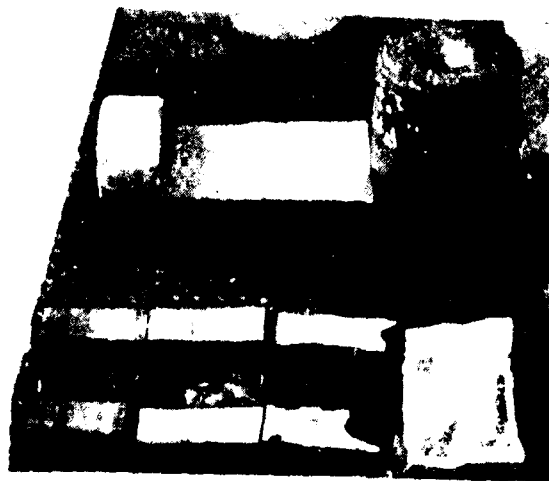

Figure 6. Sectioned Solid and Hollow Ingots with Corresponding Slag Caps - Solid on Left and Hollow Cap on Right of Ingot



Figure 7. Cross and Longitudinal Sections from Top Third of  
8 Inch Hollow Ingot

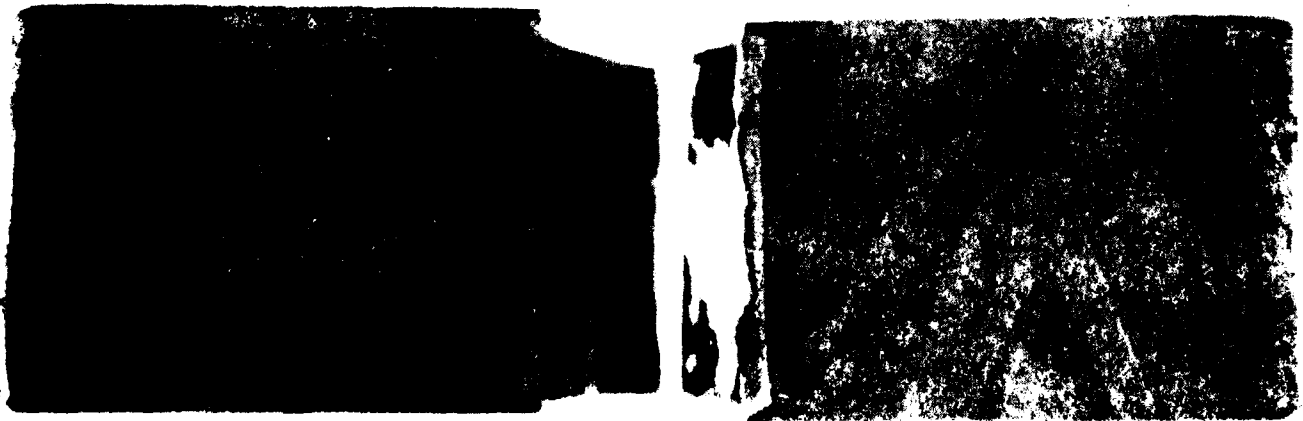
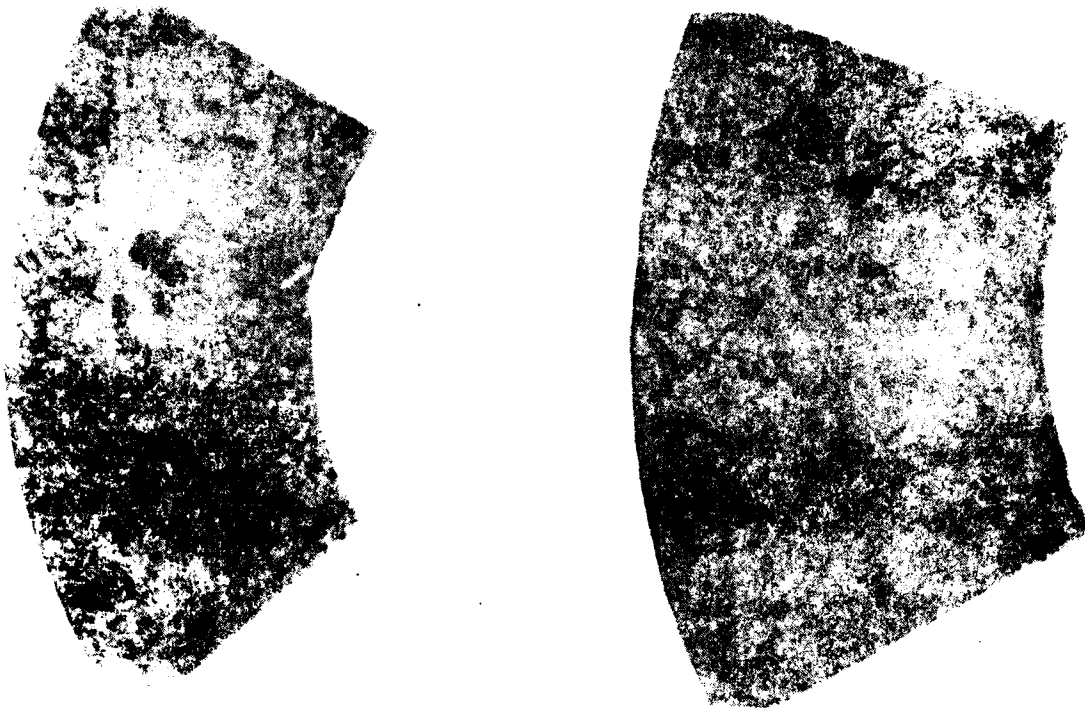

Figure 8. Cross and Longitudinal Sections from Middle of  
8 Inch Ingot

chills the metal faster than in the upper portion of the ingot. Measurements of the molten pool outline indicates that the pool depth in the top third of the ingot was about 1.1 inches. At the top of the ingot, the pool depth increased and, as a consequence, the molten slag and metal ran down between the mandrel and the I.D. wall. It should be noted from Figure 9 that the melt rate during the final third was constant, but changes in the pool depth took place which could not be accounted for. Therefore, the power should have been gradually cut back during the second half of the melt. The ID surface of the ingot was quite smooth with very few breakthroughs or laps, except where the metal had run down.

b.(3) Chemistry:

Two major sectors of concern were investigated. The first one was the comparison of the chemistry in the 6" diameter 4340 alloy electrode and its resultant 20" high ESR hollow ingot. The second was to check the amount of variation in chemistry between the top and bottom of the ESR hollow ingot.

The only notable difference was that the sulfur dropped from 0.038% in the electrode to 0.013% in the three checks that were made on the ingot, Table III.

b. (4) Mechanical Properties and Melt History:

Tensile, impact and hardness properties of the 6" diameter

# ESR 20" HIGH X 8" X 4" HOLLOW INGOT

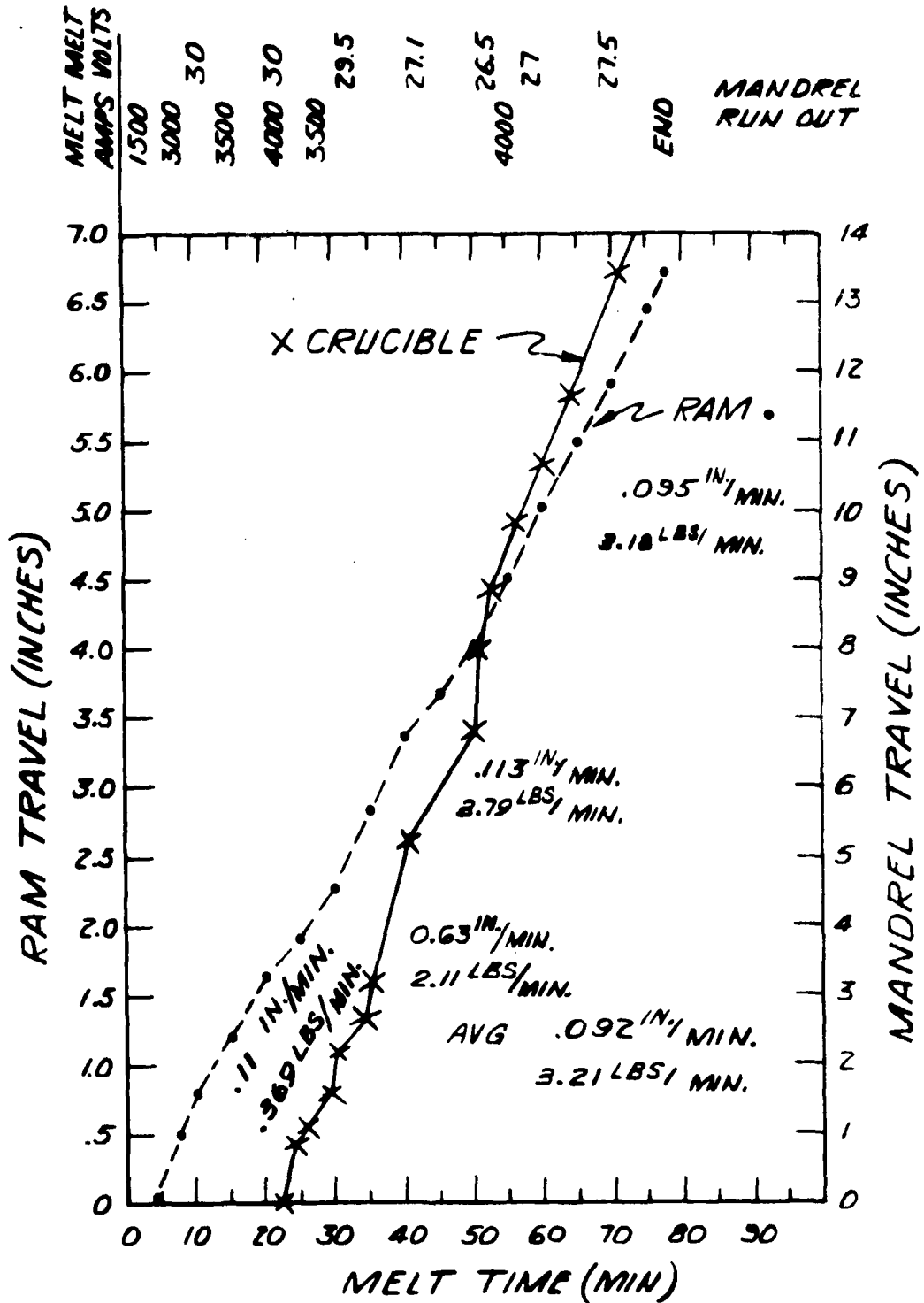

Figure 9. Melt Parameters for Various Hollow Ingots

4340 electrode versus the resultant 20" high ESR hollow ingot are presented in Table IV. The specimens from the electrode and ingot were heat treated together.

The improvement in the mechanical and chemical properties of the 20" hollow ingot again revealed the attributes of ESR melting. The emphasis was now placed upon improving the hot piercing hollow ingot technique. Therefore, melting parameters became the predominant concern.

As was stated in Paragraph b(1), Hollow Ingot Data, only three hollow ingots of practical size were produced. Because these ingots were melted under similar conditions, and the difficulties in producing them were the same, a history of only one of the ingots will be presented. The "B" ingot was selected for a description of the conditions encountered in melting.

Upon starting to melt, a four minute delay is instituted before the crucible-mandrel drive system is turned on. This is to build up a small ingot, approximately one and one-half inches, before the mandrel is set into motion, for the purpose of sealing in the liquid slag around the hollow configuration. It took 420 pounds of pressure to start the mandrel-crucible moving. Once in motion, the pressure gradually declined to about 180 pounds. Two minutes after melting, the setting on

the Parker-Hannifin control valve which controls the speed of mandrel-crucible movement was changed from 0.7 to 0.65 because the indications were that we were moving too fast. At this point in time, the hydraulic pressure went up to 300 pounds. One-half minute after the last correction, the control valve setting was lowered to 0.6 and within another two and one-half minutes, the pressure gradually leveled to 180 pounds. The control valve setting was gradually increased to 0.625 with the pressure remaining at 180 pounds. This was done because it appeared by the slag level that we were moving too slowly. This setting was maintained for another 12.2 minutes. At this time, a slight run-out occurred around the mandrel. The hydraulic drive was immediately shut off. The drive remained off by 1.6 minutes. Apparently, the pool depth was increasing. At the end of that time, the crucible mandrel drive was turned on with the setting still set at 0.625. In a short time, approximately 10 minutes, judging by the slag level, we were moving too fast. The valve setting was then lowered to 0.590. This setting was maintained until a run-out occurred. The drive systems were instantly shut off but it was too late to save the melt.

6. Current Status and Recommendations:

The ESR furnace as it currently exists is perfectly adequate for the production of solid ingots, eight inches in diameter

and 48" in height. The current system is not adequate, however, for the production of hollow ESR ingots. The major problem is the lack of a system for tracking the level of the molten metal pool and coordinating the movement of the mandrel with this level. Without such a system, the melting of a hollow depends upon a best estimate of the movement of the molten metal level and is largely a matter of chance. Furthermore, the hazards associated with an unsuccessful melt are great and range from a freezeover on the one hand to a run-out or perforated mandrel on the other. Both could have serious safety consequences to the operators.

Every successful hollow ingot program, whether in the free world or in the USSR, has at its core, the utilization of an automatic monitoring system to determine the level of the molten metal. These systems are proprietary and are believed to range from a radioactive source to various magnetic electronic devices.

The development of an automatic monitoring system for universal dissemination would be a significant contribution to the state-of-the-art and would facilitate the adoption of hollow ingot making in the industry.

## APPENDIX

Examples: Entries from Record Books - Benet Laboratories

### Melt No. 8 - 1052 to 1100 Hrs.

6" Rd. 8620 alloy electrode into an 8-1/4" OD by 4-1/4" ID ingot.

Eight minutes after start of melt, just at full power (3500 amps), slag ran down through center hole around the mandrel - shut melt down. Drive mandrel through slag.

Problem - Molten slag was too cold and also boiled making start up difficult. Turned on crucible and mandrel drive too soon after start of melt because slag boil made ingot height determination difficult.

Solution - Have molten slag to furnace hotter\* and wait longer before starting automatic cruc-mandrel drive upward.

\*Fix immersion thermocouple so the temperature can be measured.

### Melt No. 9 - 1450 to 1507 Hours.

6" Rd 8620 alloy electrode into an 8-1/4" OD x 4-1/4" ID ingot.

In this melt, the slag was hotter and we waited twice (11 min.) as long to put the cruc-mandrel into auto drive. Seventeen minutes after start of melt, the melt was terminated because we could not drive the mandrel up.

Problem - Metal formed over the top of the mandrel because the melt rate was too high, waited too long to start cruc-mandrel drive and new speed control too slow starting cruc-mandrel movement.

Solution - Slow down melt rate and/or current start up and start the cruc-mandrel drive soon and at a faster start rate.

Melt No. 10 - 1038 to 1056 Hrs.

6" Rd 8620 alloy electrode into an 8-1/4" OD x 4-1/4" ID ingot.

Eighteen minutes after a good slow start, and after the cruc-mandrel had driven up 2", we encountered an OD run down and had to shut the melt off.

Problem - The molten metal penetrated the washed-out powdered slag area and ran down the OD of the ingot.

Solution - Keep power lower in the beginning of the melt. Pour slag in faster and make a better pour - against brick. Eight or nine minutes to turning on the cruc-mandrel drive, seems good.

Melt No. 11 - 1412 Hrs. to 1425 Hrs.

5-1/4" Rd gunsteel alloy electrode into an 8" x 3" ingot.

Eleven minutes after a good slow start, the cruc-mandrel section stuck and would not move (even with prying) so the melt was terminated.

Problem - Very fluid molten metal washed very deep into the powdered Al<sub>2</sub>O<sub>3</sub> and slag mix ground the starter block, thereby keying-up the crucible wall.

Solution - Put an 8" x 1/4" thick steel starter plate on the starter block - powdered slag set up to prevent run downs, run ins, etc., that cause keying up of the crucible wall.

CRS No. 1

On this day, a three inch long hollow was accomplished. This was performed with ease because of a new type starting block. This type of block is made of carbon with four steel rods through it. This system eliminated the contraction and expansion problems at the beginning. However, the melt was aborted because of a freeze over. This melt number is CRS No. 1.

One of the major problems with our present furnace design in the making of hollows is the liquid height of the molten metal versus the mandrel height. If the mandrel moves too

slowly, the molten metal will eventually freeze over it and stop its upward motion. If the mandrel moves too fast, we have the problem of the molten metal running out underneath where the arbor is connected.

An example of the first part of the problem is shown in Melt No. CRS No. 1. After running four minutes, the mandrel-crucible drive was set on automatic. At about 150 lbs. pressure, the crucible began to move upward. A condition of equilibrium was maintained for about 18 minutes. Then the hydraulic pressure began to rise, but before a decision could be made, the pressure went to its static level and all motion ceased.

#### Later Experiments

Set up and made another hollow run. The static melting took place for two and one half minutes and then the crucible automatic drive system was turned on. It took a pressure of 400 lbs. to start the motion and then a steady force of 300 lbs. for the rest of the time. Six minutes later, a spill-out started down the side of the crucible on the northwest section. This was caused by friction lifting up the outside part of the ingot while the middle part of the ingot between the crucible wall and the mandrel was still in place. The changing slag level did not indicate any of the hidden changes even though it was rising in the crucible.

Some possible errors that could have been made were starting the crucible too early or starting with 3500 amperes instead of 4000 amperes or a combination of both. The next try will be at 4000 amperes and a start time of four minutes.

These are some of the examples of the constant problem of not knowing how deep the liquid pool is. To substantiate the significance of pool depth versus tracking, here are some excerpts from quarterly reports from the Stellite Division of the Cabot Corporation. The reports are a result of an Air Force contract (No. F33615-73-C-5046) with the Cabot Corp. The title of the contract: Manufacturing Methods for Electroslag Cast Hollows for Superalloy Rings.

March 1974 Report

#### Hot Piercing Technique

A number of trial runs have been made using the hot piercing technique. The initial trial runs were made using a hollow

electrode in order to avoid some of the problems of mandrel control. During these runs, it was determined that the use of thermocouples for detecting the molten metal level would not be sufficiently sensitive to be used for controlling the movement of the mandrel. The level of the molten metal in relation to the mandrel is a very critical problem. If the molten metal level is not high enough in relation to the top of the mandrel, the surface of the hollow is poor because of the cooling slag by the mandrel and mold walls. That is, the slag layer becomes much thicker and significantly more irregular causing a rough surface. As illustrated in Figure 1, where the metal level was kept 2-1/2" to 3" below the shoulder, the heat input is insufficient. The surface of both the I.D. and O.D. are very bad. This particular hollow was one of the first made by the "hot piercing" technique, and was approximately 6" long with a 7-5/8" O.D. and a 4-1/2" I.D. Thus, it is critical, especially for thin-walled hollows, to control the molten level near the top of the mandrel. If, however, the molten metal level rises above the mandrel shoulder, the metal then, of course, freezes and the mandrel becomes stuck in the hollow. Various techniques have been employed in an attempt to accurately measure the molten metal and up to now none have been sufficiently sensitive. Thus, in order to keep the unit in operation, a compromise, as to where the molten metal level was maintained, was reached. That is, it was decided to accept a poorer ID surface to keep from having to machine out the mandrel. The molten metal is thus maintained from 2" to 3" below the shoulder which is at least one inch too low to yield an acceptable ingot surface.

#### September 1974 Report

Two significant problems were encountered in the subscale work: (a) measurement of the molten metal level and (b) lack of melt power in the unit. These two problems combined to produce an ingot with a poor surface. A solution to the former problem, that of molten metal level detection, is incorporated into the design of the full scale unit.

TABLE I  
TENSILE, IMPACT AND HARDNESS PROPERTIES OF 4340  
ELECTRODE VS. ESR MELTED SOLID INGOT

<u>SPECIMEN LOCATION AND NO.</u>	<u>0.1% YS (ksi)</u>	<u>TENSILE (ksi)</u>	<u>E1 %</u>	<u>RA %</u>	<u>IMPACT STRENGTH FT-LBS</u>	<u>HARDNESS R<sub>c</sub></u>
Electrode	135	151	7.9	13.0	17.9	34-35
1BS (Bottom)	128	134	6.9	15.4	32.6	34-35
3BS (1/3)	138	157	17.1	49.4	27.8	34-35
5BS (Middle)	137	156	14.0	29.5	31.1	34-35
7BS (2/3)	138	156	15.0	40.7	25.2	34-35
9BS (Top)	138	156	14.7	42.4	21.0	34-35

All bars heat treated as follows:

1550°F - 2 Hr. W.Q. + 1100°F - 2 Hr. W.Q.

TABLE II

CHEMISTRY OF 4340 ELECTRODE VS. ESR SOLID INGOT

<u>SPECIMEN LOCATION &amp; POSITION</u>	<u>C (%)</u>	<u>Mn (%)</u>	<u>P (%)</u>	<u>S (%)</u>	<u>Si (%)</u>	<u>Ni (%)</u>	<u>Cr (%)</u>	<u>Mo (%)</u>
Electrode	.43	.70	.009	.022	.28	2.09	.93	.22
1BS (Bottom)	.41	.64	.011	.003	.20	2.00	.91	.23
3BS (1/3)	.40	.64	.009	.004	.22	2.00	.91	.23
5BS (Middle)	.40	.68	.008	.002	.22	2.00	.95	.22
7BS (2/3)	.39	.66	.008	.004	.23	1.95	.94	.23
9BS (Top)	.41	.67	.010	.005	.23	1.96	.95	.23

TABLE III

CHEMISTRY OF 4340 ELECTRODE VS. ESR HOLLOW INGOT

<u>SPECIMEN LOCATION &amp; POSITION</u>	<u>C (%)</u>	<u>Mn (%)</u>	<u>P (%)</u>	<u>S (%)</u>	<u>Si (%)</u>	<u>Ni (%)</u>	<u>Cr (%)</u>	<u>Mo (%)</u>
Electrode	.41	.71	.016	.038	.29	2.00	.94	.22
INGOT								
Bottom	.40	.58	.015	.013	.22	2.00	.94	.22
Middle	.41	.69	.016	.006	.21	2.00	.94	.22
Top	.40	.63	.015	.013	.20	1.92	.93	.22

TABLE IV

TENSILE, IMPACT AND HARDNESS PROPERTIES OF 4340  
ELECTRODE VS. ESR HOLLOW INGOT

<u>SPECIMEN LOCATION &amp; POSITION</u>	<u>0.1% YS (ksi)</u>	<u>Tensile (ksi)</u>	<u>E1 (%)</u>	<u>RA (%)</u>	<u>IMPACT STRENGTH (FT-LBS)</u>	<u>HARDNESS (R<sub>C</sub>)</u>
Electrode	135	151	10.0	19.1	17.5	34-35
INGOT						
Bottom	129	150	16.4	50.2	38.7	33-34
Middle	127	149	17.1	49.8	41.8	32-33
Top	125	148	17.1	52.5	41.2	33-33

All bars heat treated as follows:

1550°F - 2 Hr. W.Q. + 1100°F - 2 Hr. W.Q.

TECHNICAL REPORT INTERNAL DISTRIBUTION LIST

	<u>NO. OF COPIES</u>
COMMANDER	1
CHIEF, DEVELOPMENT ENGINEERING BRANCH	1
ATTN: DRDAR-LCB-DA	1
-DM	1
-DP	1
-DR	1
-DS	1
-DC	1
CHIEF, ENGINEERING SUPPORT BRANCH	1
ATTN: DRDAR-LCB-SE	1
-SA	1
CHIEF, RESEARCH BRANCH	2
ATTN: DRDAR-LCB-RA	1
-RC	1
-RM	1
-RE	1
CHIEF, LWC MORTAR SYS. OFC.	1
ATTN: DRDAR- LCB-M	1
CHIEF, IMP. 81MM MORTAR OFC.	1
ATTN: DRDAR- LCB-I	1
TECHNICAL LIBRARY	5
ATTN: DRDAR- LCB-TL	
TECHNICAL PUBLICATIONS & EDITING UNIT	2
ATTN: DRDAR- LCB-TL	
DIRECTOR, OPERATIONS DIRECTORATE	1
DIRECTOR, PROCUREMENT DIRECTORATE	1
DIRECTOR, PRODUCE ASSURANCE DIRECTORATE	1

NOTE: PLEASE NOTIFY ASSOC. DIRECTOR, BENET WEAPONS LABORATORY, ATTN:  
DRDAR- LCB-TL, OF ANY REQUIRED CHANGES.

TECHNICAL REPORT EXTERNAL DISTRIBUTION LIST

	<u>NO. OF COPIES</u>		<u>NO. OF COPIES</u>
ASST SEC OF THE ARMY RESEARCH & DEVELOPMENT ATTN: DEP FOR SCI & TECH THE PENTAGON WASHINGTON, D.C. 20315	1	COMMANDER US ARMY TANK-AUTMV R&D COMD ATTN: TECH LIB - DRDTA-UL MAT LAB - DRDTA-RK WARREN MICHIGAN 48090	1 1
COMMANDER US ARMY MAT DEV & READ. COMD ATTN: DRUDE 5001 EISENHOWER AVE ALEXANDRIA, VA 22333	1	COMMANDER US MILITARY ACADEMY ATTN: CHMN, MECH ENGR DEPT WEST POINT, NY 10996	1
COMMANDER US ARMY ARRADCOM ATTN: DRDAR-IC -ICA (PLASTICS TECH EVAL CEN) -ICE -ICM -ICS -ICW -TSS(STINFO) DOVER, NJ 07801	1 1 1 1 1 1 2	COMMANDER REDSTONE ARSENAL ATTN: DRSMI-RB -RRS -RSM ALABAMA 35809 COMMANDER ROCK ISLAND ARSENAL ATTN: SARRI-ENM (MAT SCI DIV) ROCK ISLAND, IL 61202	2 1 1 1 1
COMMANDER US ARMY ARRCOM ATTN: DR SAR-LEP-L ROCK ISLAND ARSENAL ROCK ISLAND, IL 61299	1	COMMANDER HQ, US ARMY AVN SCH ATTN: OFC OF THE LIBRARIAN FT RUCKER, ALABAMA 36362	1
DIRECTOR US Army Ballistic Research Laboratory ATTN: DRDAR-TSB-S (STINFO) ABERDEEN PROVING GROUND, MD 21005	1	COMMANDER US ARMY FGN SCIENCE & TECH CEN ATTN: DRXST-SD 220 7TH STREET, N.E. CHARLOTTESVILLE, VA 22901	1
COMMANDER US ARMY ELECTRONICS COMD ATTN: TECH LIB FT MONMOUTH, NJ 07703	1	COMMANDER US ARMY MATERIALS & MECHANICS RESEARCH CENTER ATTN: TECH LIB - DRXMR-PL WATERTOWN, MASS 02172	2
COMMANDER US ARMY MOBILITY EQUIP R&D COMD ATTN: TECH LIB FT BELVOIR, VA 22060	1		

**NOTE:** PLEASE NOTIFY COMMANDER, ARRADCOM, ATTN: BENET WEAPONS LABORATORY, DRDAR-ICB-TL, WATERVLIET ARSENAL, WATERVLIET, N.Y. 12189, OF ANY REQUIRED CHANGES.

TECHNICAL REPORT EXTERNAL DISTRIBUTION LIST (CONT)

	<u>NO. OF COPIES</u>		<u>NO. OF COPIES</u>
COMMANDER US ARMY RESEARCH OFFICE P.O. BOX 12211 RESEARCH TRIANGLE PARK, NC 27709	1	COMMANDER DEFENSE TECHNICAL INFO CENTER ATTN: DTIA-TCA CAMERON STATION ALEXANDRIA, VA 22314	12
COMMANDER US ARMY HARRY DIAMOND LAB ATTN: TECH LIB 2900 POWDER MILL ROAD APENLPHIA, MD 20783	1	METALS & CERAMICS INFO CEN BATTELLE COLUMBUS LAB 505 KING AVE COLUMBUS, OHIO 43201	1
DIRECTOR US ARMY INDUSTRIAL BASE ENG ACT ATTN: DRXPE-MT ROCK ISLAND, IL 61201	1	MECHANICAL PROPERTIES DATA CTR BATTELLE COLUMBUS LAB 505 KING AVE COLUMBUS, OHIO 43201	1
CHIEF, MATERIALS BRANCH US ARMY R&S GROUP, EUR BOX 65, FPO N.Y. 09510	1	MATERIEL SYSTEMS ANALYSIS ACTV ATTN: DRXSY-MP ABERDEEN PROVING GROUND MARYLAND 21005	1
COMMANDER NAVAL SURFACE WEAPONS CEN ATTN: CHIEF, MAT SCIENCE DIV DAHLGREN, VA 22448	1		
DIRECTOR US NAVAL RESEARCH LAB ATTN: DIR, MECH DIV CODE 26-27 (DOC LIB) WASHINGTON, D. C. 20375	1 1		
NASA SCIENTIFIC & TECH INFO FAC P. O. BOX 8757, ATTN: ACQ BR BALTIMORE/WASHINGTON INTL AIRPORT MARYLAND 21240	1		

NOTE: PLEASE NOTIFY COMMANDER, ARRADCOM, ATTN: BENET WEAPONS LABORATORY, DRDAR-ICB-TL, WATERVLIET ARSENAL, WATERVLIET, N.Y. 12189, OF ANY REQUIRED CHANGES.