

AD-A087 291

COBER ELECTRONICS INC STAMFORD CT
HIGH VOLTAGE NANOSECOND PULSE GENERATOR. (U)
JUL 80 C ZAVALAS

F/6 14/2

UNCLASSIFIED

DAAB07-77-C-2641

DELET-TR-77-2641-5

NL

1 of 1
40 0
7/72 21



END
DATE
FILMED
9-80
DTIC

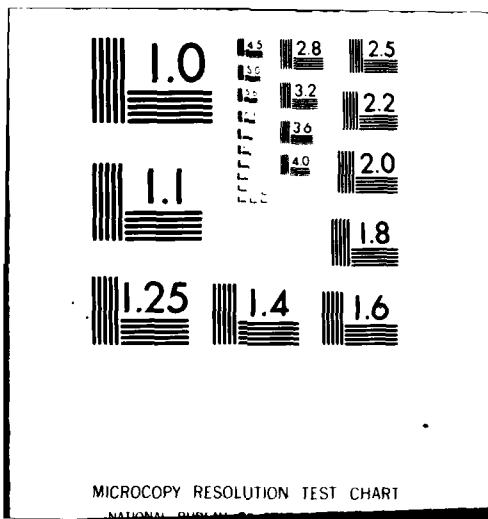

MICROCOPY RESOLUTION TEST CHART

NATIONAL BUREAU OF STANDARDS-1963-A



LEVEL *IV*

12

RESEARCH AND DEVELOPMENT TECHNICAL REPORT
DELET-TR-77-2641-5

HIGH VOLTAGE NANOSECOND PULSE GENERATORS

ADA 087291

C. Zavales
COBER ELECTRONICS
7 Gleason Avenue
Standford, CT 06902

DTIC
ELECTE
JUL 30 1980
D
C

May 1980

Fifth Interim Report for Period 1 May 79 - 31 Oct 79

DISTRIBUTION STATEMENT
Approved for public release;
distribution unlimited.

Prepared for:
Electronics Technology & Devices Laboratory

ERADCOM

US ARMY ELECTRONICS RESEARCH & DEVELOPMENT COMMAND
FORT MONMOUTH, NEW JERSEY 07703

DDC FILE COPY

HISA-FM 196-78

80 7 21 034

NOTICES

Disclaimers

The citation of trade names and names of manufacturers in this report is not to be construed as official Government indorsement or approval of commercial products or services referenced herein.

Disposition

Destroy this report when it is no longer needed. Do not return it to the originator.

| 19 REPORT DOCUMENTATION PAGE | | READ INSTRUCTIONS BEFORE COMPLETING FORM |
|---|-----------------------------------|--|
| 18 DELET-TR-77-2641-5 | 2. GOVT ACCESSION NO. AD-A087 291 | 3. RECIPIENT'S CATALOG NUMBER |
| 4. TITLE (and Subtitle) High Voltage Nanosecond Pulse Generator | | 5. TYPE OF REPORT & PERIOD COVERED 5th Interim Technical Report 1 May 1979 - 31 October 1979 |
| 7. AUTHOR(s) C./Zavales | | 6. PERFORMING ORG. REPORT NUMBER |
| 9. PERFORMING ORGANIZATION NAME AND ADDRESS Cober Electronics, Inc. 7 Gleason Avenue Stamford, CT 06902 | | 8. CONTRACT OR GRANT NUMBER(s) DAAB07-77-C-2641 |
| 11. CONTROLLING OFFICE NAME AND ADDRESS USA Electronics Technology & Devices Laboratory ATTN: DELET-BG Fort Monmouth, NJ 07703 | | 10. PROGRAM ELEMENT, PROJECT, TASK AREA & WORK UNIT NUMBERS 62705 1L762705 AH 94 02-01 |
| 14. MONITORING AGENCY NAME & ADDRESS (if different from Controlling Office) Interim Technical Report 1 MSV-77 Oct 79 | | 12. REPORT DATE Jul 1980 |
| 16. DISTRIBUTION STATEMENT (of this Report) Approved for Public Release; Distribution Unlimited | | 13. NUMBER OF PAGES 9 |
| 17. DISTRIBUTION STATEMENT (of the abstract entered in Block 20, if different from Report) | | 15. SECURITY CLASS. (of this report) Unclassified |
| 18. SUPPLEMENTARY NOTES | | 15a. DECLASSIFICATION/DOWNGRADING SCHEDULE |
| 19. KEY WORDS (Continue on reverse side if necessary and identify by block number) Pulse Generation Switching Spark Gap Blumlein Avalanche Transistor | | |
| 20. ABSTRACT (Continue on reverse side if necessary and identify by block number) A parallel Blumlein circuit, combined with a spark gap switch, was designed for operation at 24 kV, 5,000 A peak. Tests were conducted with a single Blumlein with a 10 ohm load. Because of problems with breakdown in the triggered spark gap, a slightly larger spark gap was substituted. An acceptable pulse is delivered from the pulse forming network after adjustment of the inductive elements in the network. | | |

393233

508

TABLE OF CONTENTS

| | <u>Page</u> |
|-----------------------------------|-------------|
| I. INTRODUCTION. | 1 |
| II. TASK II REQUIREMENTS. | 2 |
| III. CONCLUSION. | 9 |

| | |
|--------------------|-------------------------------------|
| Accession For | |
| NTIS GRA&I | <input checked="" type="checkbox"/> |
| DDC TAB | <input type="checkbox"/> |
| Unannounced | <input type="checkbox"/> |
| Justification | |
| By _____ | |
| Distribution/ | |
| Availability Codes | |
| Dist | Avail and/or special |
| A | |

LIST OF FIGURES

| <u>Figure No.</u> | | <u>Page</u> |
|-------------------|--|-------------|
| I. | BASIC MODULATOR. | 3 |
| II. | TEST MODULATOR | 5 |
| III. | TEST MODULATOR (w/MOSFET TRIGGER) | 6 |
| IV. | FINAL MODULATOR (w/MOSFET TRIGGER) | 10 |

I. INTRODUCTION

This report covers work during the period 1 May 1979 to 31 October 1979 on Contract DAAB07-77-C-2641 to develop a pulser for a TEA laser with a 10 mm gap. This is Task I. For Task II a pulser for a TEA laser is the same as for Task I, but operates at a variable PRR. The PRR for Task I is 15Hz. The work is being performed by Cober Electronics in Stamford, Connecticut for the U. S. Army Electronics Command, Fort Monmouth, New Jersey. The work is directed towards fulfilling the requirements of Task I and Task II Technical Guidelines entitled "High Voltage Nanosecond Pulse Generators" dated 18 December 1978. Listed below are the requirements for Task I and Task II.

Task I Requirements

| | |
|---------------------|------------------------------|
| Output Voltage | : 24 kV |
| Peak Current | : 5000 A |
| PRR | : 15 Hz |
| Pulsewidth (50%) | : 100 ns |
| Risetime | : 30 ns max |
| Pulse Energy Output | : 12 J |
| Pulser Efficiency | : 90% min (resistive load) |
| Life | : 4×10^6 pulses min |
| Weight | : 3.0 kg max |
| Volume | : 1200 cm^3 max |

Cober

Input Battery Voltage : 28 V
Mode of Operation : 30 sec burst
Interval Between Bursts : 60 sec

Task II Requirements

Output Voltage : 24 kV
Peak Current : 5000 A
PRR : 1 to 20 Hz variable, & single shot
Pulsewidth (50%) : 100 us
Risettime (10 to 90%) : 30 ns min
Pulse Energy Output : 12 J
Pulser Efficiency : 90% min
Weight : 3.0 kg max
Volume : 1200 cm³ max
Input Battery Voltage : 28 V
Mode of Operation : 30 sec burst
Interval Between Bursts : 60 sec

The original approaches are shown in Figure I.

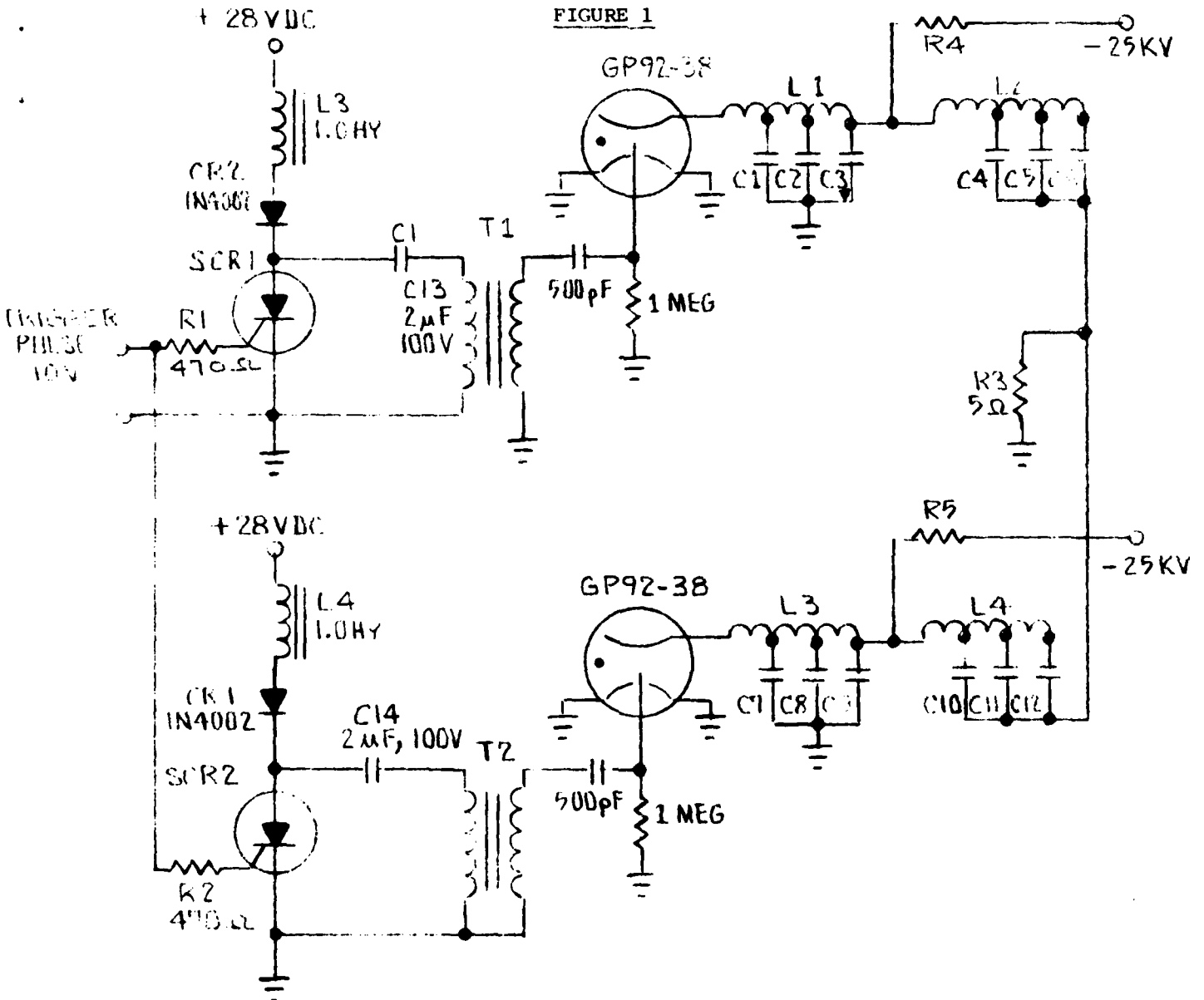

L1, L2, L3, L4 = .25 uh.

C1-C12 = 3300 PF, 30KV

R4-R5 = .5 meg

T1, T2 = TR 1647 by E.G. & G.

To simplify the engineering appraisal, the original schematic shown in Figure I was reduced to the schematic shown in Figure II. The rating now was 250 amperes at 24kV into a 10 ohm load.

FIGURE II

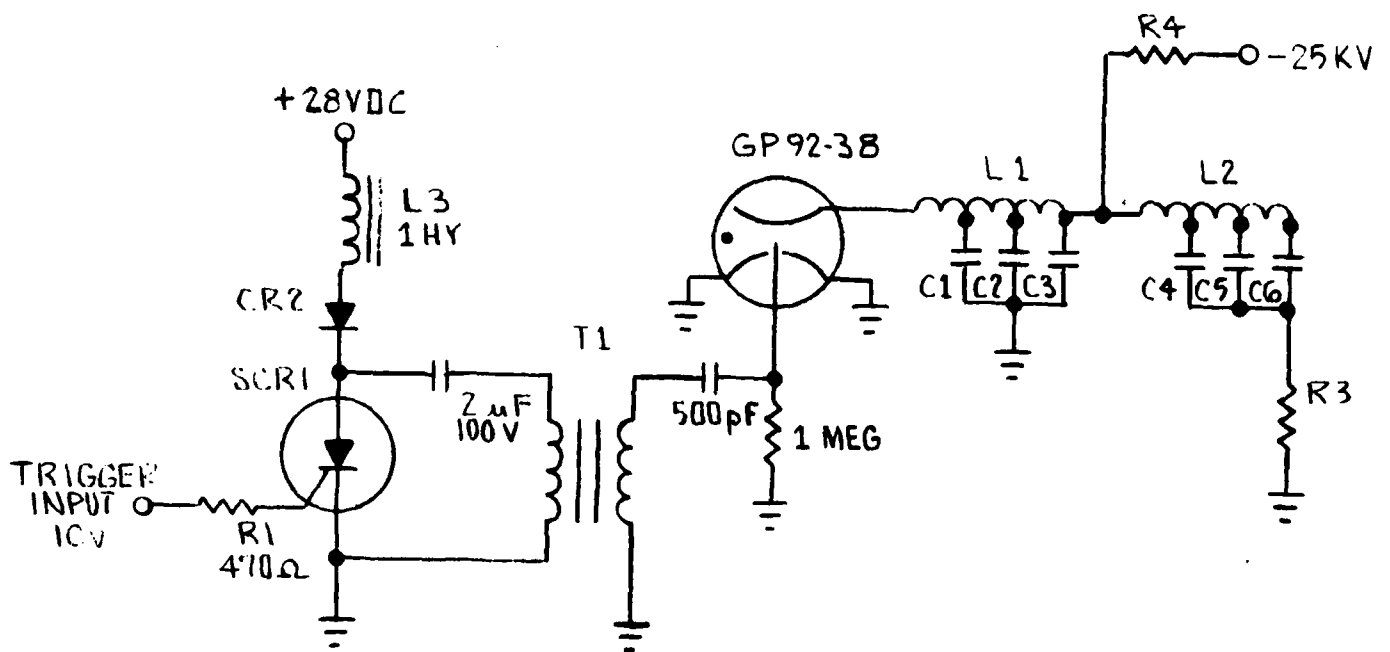

L1, L2 = .25 uh.

C1-C6 = 3300 PF, 30KV

R4 = 15 meg

T1 = TR 1647 by E.G. & G.

An assembly in accordance with Figure II was constructed. Several problems were apparent. T1 did not provide sufficient voltage to trigger the GP92-38 trigger gap, 15KV was needed. Another triggering circuit was constructed using 250VDC and a TR1700 trigger transformer. Another problem became apparent. The GP92-38 required immersion in oil because surface breakdown between the trigger electrode and adjacent electrode occurred.

Further testing revealed still another problem. The SCR1 occasionally did not turn off, especially when a burst of trigger pulses were used. A redundant external commutating circuit was in order or a power mosfet transistor was desirable. The power mosfet transistor was chosen in the interests of simplicity and reliability.

In view of the triggering problems and necessity for oil immersion, a larger trigger gap, GP-87, was substituted. This would simplify the final circuit arrangement. The GP-87, while slightly larger than 2 each GP92-38 trigger gaps, also has a higher output electrode rating of 2000 joules versus 50 joules for the two GP92-38 trigger gaps.

The assembly was now in accordance with schematic shown in Figure III.

FIGURE III

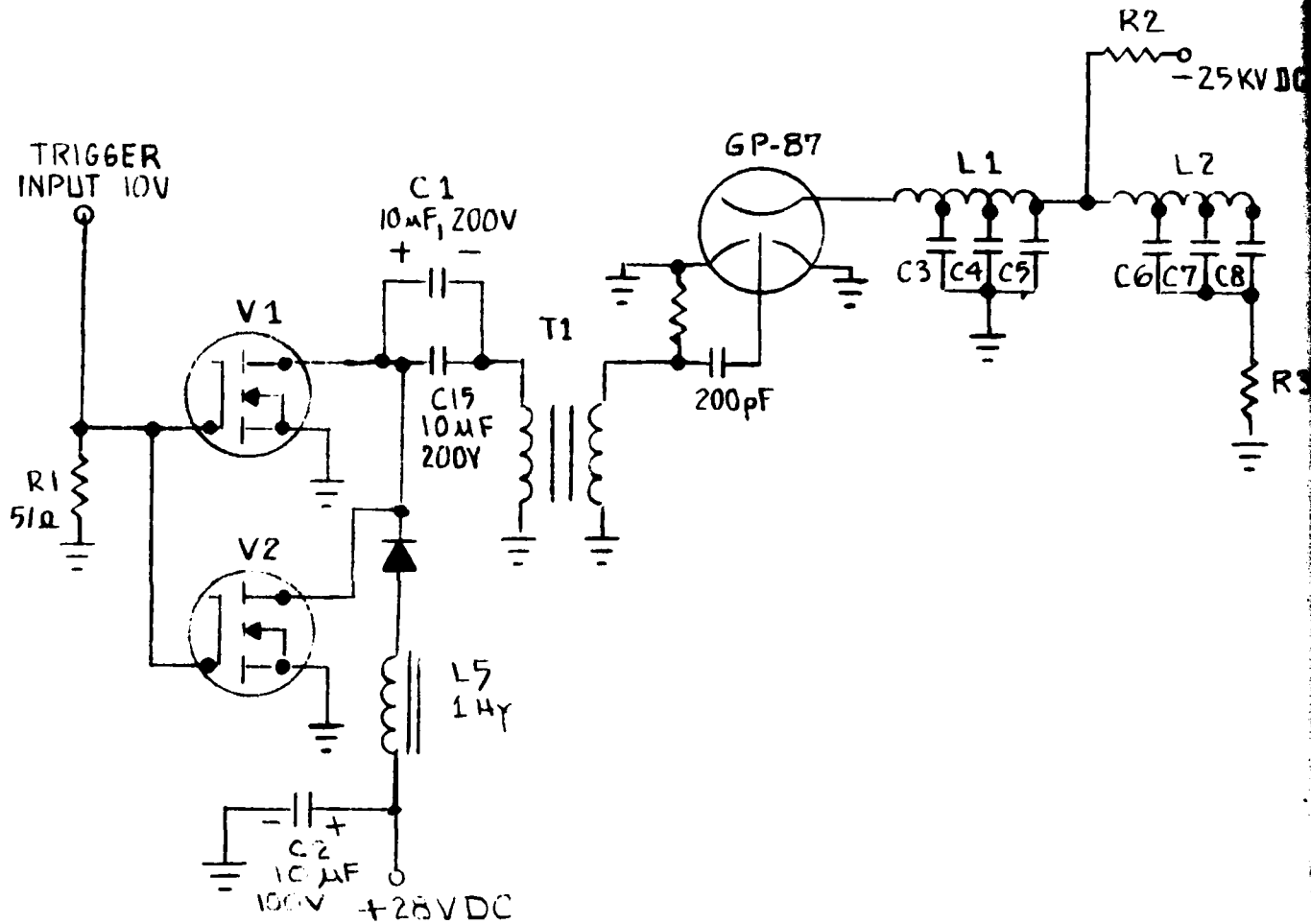

V1, V2 - Power Mosfet IRF 133 by International Rect. Semi

T1 - TR1938 by E.G. & G.

GP87 - Trigger Gap by E.G. & G.

L1, L2 - .25 uf. inductance by Cober

C3-C8 - 3300 PF, 30KV

R3 - 10 ohm Load Resistor

R2 - .5 meg

The pulse forming network, a Blumlein configuration was examined. Initial efforts did not produce an acceptable pulse across the load resistor R3. The mechanical arrangement of the pulse forming network required a change. While the average power into the load was low, especially in a one shot mode, still the peak currents were high, 2500 amperes as a goal. Additionally, a reasonable match between the impedance of the network and the load was required to obtain a satisfactory pulse shape.

When a mechanical arrangement minimizing interconnecting lead lengths and strip conductors were used, satisfactory amplitude and pulse shape was achieved. In the final prototype these considerations will get attention.

Figure IV represents the planned configuration to achieve the specified current of 5000 A and the specified voltage of 24kV across the load resistor. Additionally, the trigger input, while not specified, is desired as at a TTL level (3-4V peak) instead of the 10V used in the testing. A suitable arrangement was devised and is shown on the schematic.

An assembly in accordance with the schematic in Figure IV was made. The circuit to accept TTL trigger input was omitted initially. At the time, the unspecified but desirable requirement of TTL input was not known.

The results, with some effort in minimizing lead lengths, were satisfactory.

Cober

An item worthy of mention, is the load. Because the current peaks are quite high, the peak voltage requirement is high. The design of the load resistor required some effort. The width of the output pulse added another factor in creating a suitable load. Several suitable loads were created to verify the adequateness of the load. An assembly of parallel branches of carbon resistors and an assembly using a coaxial structure produced similar results.

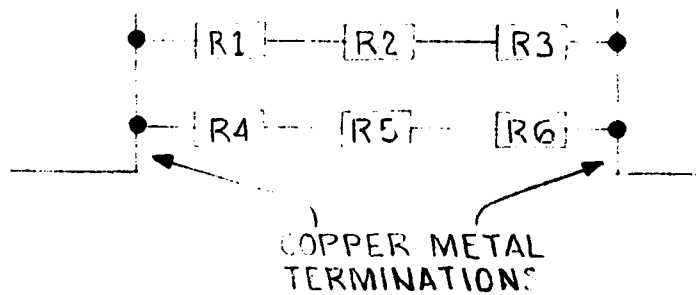
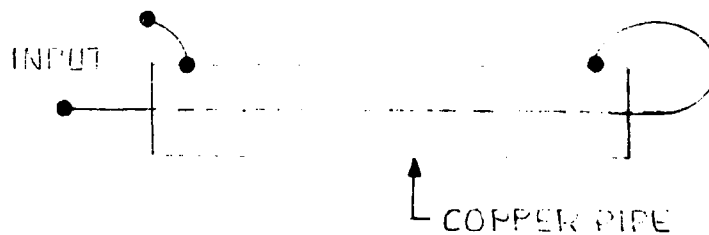

Only 2 branches are shown, but actually enough branches were used to achieve ≈ 5 ohms. Resistors were 2 watt carbon composition resistors of 18 ohms each.

CONCLUSION:

Task I and II differ only in the PRR as depicted by the specifications.

The actual hardware for Task I and Task II are the same.

The circuitry to accept TTL input has not been tested in the breadboard assembly as of this report. It is the same as employed successfully in Task III of the High Voltage Nano-second Pulse Generator Program.

The specified volume appears attainable through the final mechanical arrangement has not been made as of this report.

New smaller capacitors for the pulse forming network should be in house within a month.

Indications are that the final prototype configuration will meet the specified requirements.

FIGURE IV

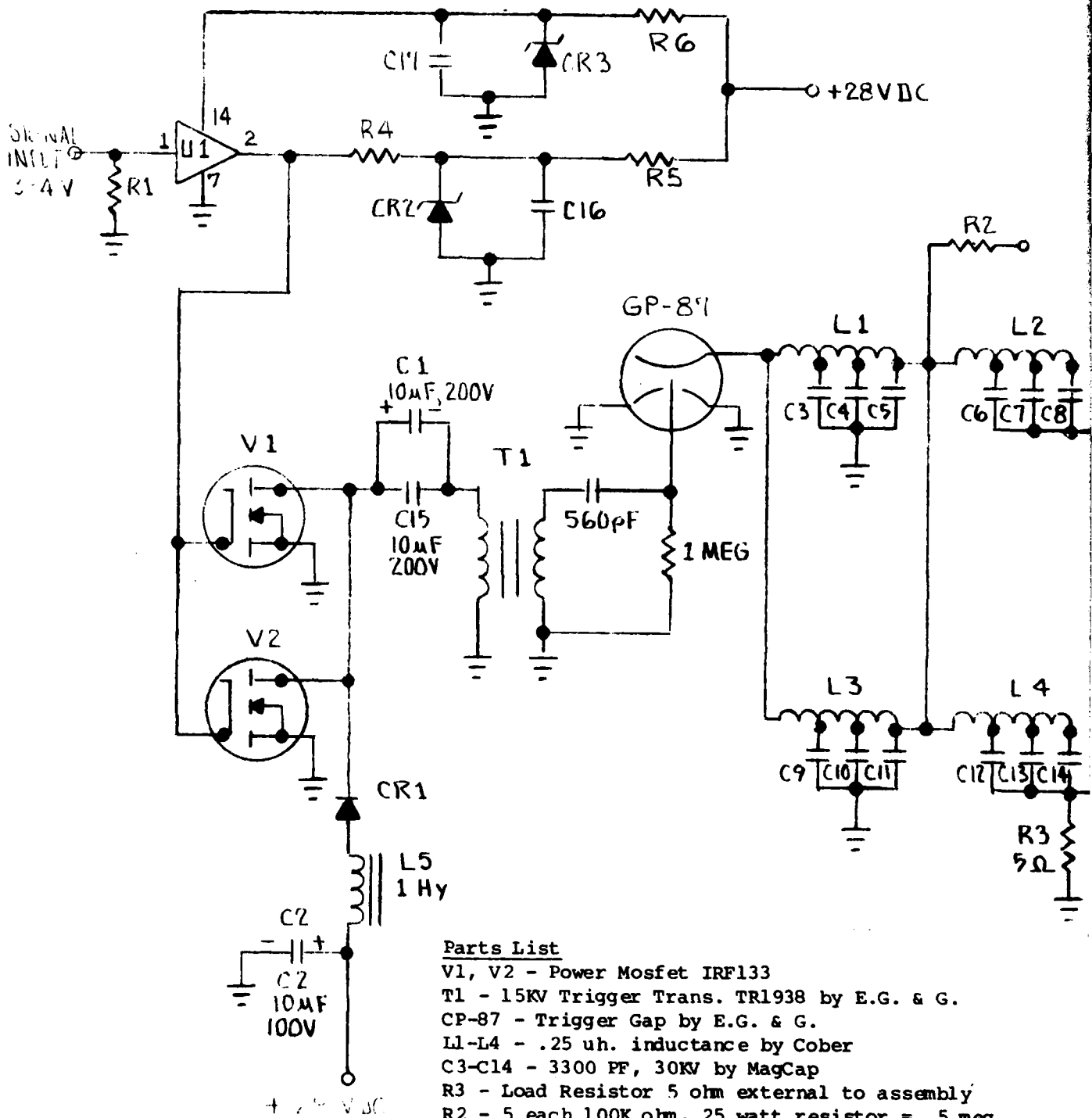

Parts List

- V1, V2 - Power Mosfet IRF133
- T1 - 15KV Trigger Trans. TR1938 by E.G. & G.
- GP-87 - Trigger Gap by E.G. & G.
- L1-L4 - .25 uh. inductance by Cober
- C3-C14 - 3300 PF, 30KV by MagCap
- R3 - Load Resistor 5 ohm external to assembly
- R2 - 5 each 100K ohm, 25 watt resistor = .5 meg.
- R4 - 510 ohm, 2 watt carbon
- R5 - 390 ohm, 2 watt carbon
- R6 - 390 ohm, 2 watt carbon
- U1 - SN7417J
- C16, C17 - .47 mfd, 50V
- CR1 - 1N4007
- CR2 - 1N2024A
- CR3 - 1N3826A

DISTRIBUTION LIST

- 12 Defense Documentation Center
ATTN: DDC-TCA
Cameron Station (Bldg 5)
Alexandria, VA 22314
- 1 Code R123, Tech Library
DCA Defense Comm Engrg Ctr
1860 Wiehle Ave
Reston, VA 22090
- 1 Defense Communications Agency
Technical Library Center
Code 205 (P.A. TOLOVI)
Washington, DC 20305
- 1 Office of Naval Research
Code 427
Arlington, VA 22217
- 1 Director
Naval Research Laboratory
ATTN: Code 2627
Washington, DC 20375
- 1 Commander
Naval Ocean Systems Center
ATTN: Library, Code WX 21
San Diego, CA 92152
- 1 CDR, Naval Surface Weapons Center
White Oak Laboratory
ATTN: Library, Code WX-21
Silver Spring, MD 20910
- 1 Rome Air Development Center
ATTN: Documents Library (TILD)
Griffiss AFB, NY 13441
- 1 Hq, Air Force Systems Command
ATTN: DLCA
Andrews AFB
Washington, DC 20331
- 2 CDR, US Army Missile Command
Redstone Scientific Info Center
ATTN: Chief, Document Section
Redstone Arsenal, AL 35809

- 3 Commandant
US Army Aviation Center
ATTN: ATZQ-D-MA
Fort Rucker, AL 36362
- 1 Director, Ballistic Missile Defense
Advanced Technology Center
ATTN: ATC-R, PO BOX 1500
Huntsville, AL 35807
- 1 Commander
HQ Fort Huachuca
ATTN: Technical Reference Div
Fort Huachuca, AZ 85613
- 2 Commander
US Army Electronic Proving Ground
ATTN: STEEP-MT
Fort Huachuca, AZ 85613
- 1 Deputy for Science & Technology
Office, Assist Sec Army (R&D)
Washington, DC 20310
- 1 CDR, Harry Diamond Laboratories
ATTN: Library
2800 Powder Hill Road
Adelphi, MD 20783
- 1 Director
US Army Ballistic Research Labs
ATTN: DRXBR-LB
Aberdeen Proving Ground, MD 21005
- 1 Harry Diamond Laboratories, Dept of Army
ATTN: DRXDO-RCB (Dr. J. Nemarich)
2800 Powder Hill Road
Adelphi, MD 20783
- 1 Commander, TARCOT
US Army Tank-Automotive Command
ATTN: DRDTA-RH
Warren, MI 48090

1 CDR, AVRADCOM
ATTN: DRSAV-E
PO Box 209
St. Louis, MO 63166

1 TRI-TAC Office
ATTN: TT-SE
Fort Monmouth, NJ 07703

1 CDR, US Army Research Office
ATTN: DRXRO-IP
PO Box 12211
Research Triangle Park, NC 27709

1 CDR, US Army Research Office
ATTN: DRXRO-PH (Dr. R. J. Lontz)
PO Box 12211
Research Triangle Park, NC 27709

1 Commandant
US Army Air Defense School
ATTN: ATSA-CD-MC
Fort Bliss, TX 79916

1 Commander, DARCOM
ATTN: DRCDE
5001 Eisenhower Ave.
Alexandria, VA 22333

1 Chief
Ofc of Missile Electronic Warfare
Electronic Warfare Lab, ERADCOM
White Sands Missile Range, NM 88002

Commander
US Army Electronics R&D Command
Fort Monmouth, NJ 07703

1 DRDEL-SA
1 DELEW-D
3 DELCS-D
1 DELET-D
1 DELET-DT
5 DELET-BG
1 DELSD-D
1 DELSD-AS
1 DELSD-L (Tech Library)
2 DELSD-L-S (Stinfo)
25 Originating Office

- 2 MIT - Lincoln Laboratory
ATTN: Library (RM A-082)
PO Box 73
Lexington, MA 02173
- 1 NASA Scientific & Tech Info Facility
Baltimore/Washington Intl Airport
PO Box 8757, MD 21240
- 2 Advisory Group on Electron Devices
201 Varick Street, 9th Floor
New York, NY 10014
- 1 Physics International
ATTN: Mr. B. Yen
2700 Mercer Street
San Leandro, California 94577
- 1 Fusion Industries, Inc.
ATTN: Mr. Vernon L. Smith
P.O. Box 31813
Dallas, Texas 75231