

AD-A087 558

GENERAL ELECTRIC CO UTICA NY AEROSPACE ELECTRONIC SY--ETC F/G 20/6
COMMON APERTURE TECHNIQUES FOR IMAGING ELECTRO-OPTICAL SENSORS --ETC(U)
FEB 80 F33615-76-C-1135
79-556C0-10 AFWAL-TR-80-1012 NL

UNCLASSIFIED

1 of
AREA
COVER

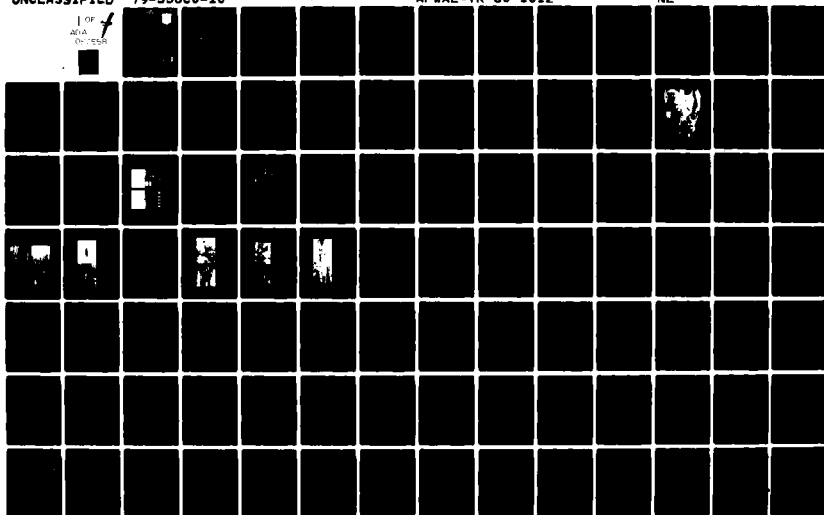

LEVEL II



AFWAL-TR-80-1012

ADA 087558

COMMON APERTURE TECHNIQUES FOR IMAGING ELECTRO-OPTICAL SENSORS (CATIES)

Engineering Staff
General Electric Company
Aircraft Equipment Division
Utica, New York

February 1980

TECHNICAL REPORT AFWAL-TR-80-1012

Final Report for Period July 1976 to November 1979

Approved for public release; distribution unlimited.

DTIC
ELECTE
S AUG 4 1980 D
D

AVIONICS LABORATORY
AIR FORCE WRIGHT AERONAUTICAL LABORATORIES
AIR FORCE SYSTEMS COMMAND
WRIGHT-PATTERSON AIR FORCE BASE, OHIO 45433

UNU

80 8 1 094

NOTICE

When Government drawings, specifications, or other data are used for any purpose other than in connection with a definitely related Government procurement operation, the United States Government thereby incurs no responsibility nor any obligation whatsoever; and the fact that the government may have formulated, furnished, or in any way supplied the said drawings, specifications, or other data, is not to be regarded by implication or otherwise as in any manner licensing the holder or any other person or corporation, or conveying any rights or permission to manufacture use, or sell any patented invention that may in any way be related thereto.

This report has been reviewed by the Office of Public Affairs (ASD/PA) and is releasable to the National Technical Information Service (NTIS). At NTIS, it will be available to the general public, including foreign nations.

This technical report has been reviewed and is approved for publication.



JAMES J. STEWART, Project Engineer
Thermal Imaging Group
Reconnaissance & Weapon Delivery Div.
Avionics Laboratory



DR PAUL F. McMANAMON, Chief
Thermal Imaging Group
Reconnaissance & Weapon Delivery Div.
Avionics Laboratory

FOR THE COMMANDER



GALE D. URBAN, Chief
Electro-Optics & Reconnaissance Br.
Reconnaissance & Weapon Delivery Div.
Avionics Laboratory

"If your address has changed, if you wish to be removed from our mailing list, or if the addressee is no longer employed by your organization please notify AFNAL/AARI, W-PAFB, OH 45433 to help us maintain a current mailing list".

Copies of this report should not be returned unless return is required by security considerations, contractual obligations, or notice on a specific document.

UNCLASSIFIED

11 Feb 80 L

SECURITY CLASSIFICATION OF THIS PAGE (When Data Entered)

(9) REPORT DOCUMENTATION PAGE		READ INSTRUCTIONS BEFORE COMPLETING FORM	
1. REPORT NUMBER AFWAL-TR-80-1012	2. GOVT ACCESSION NO. AD-A087	3. RECIPIENT'S CATALOG NUMBER 558	
4. TITLE (and Subtitle) Common Aperture Techniques for Imaging Electro-Optical Sensors (CATIES)	5. TYPE OF REPORT & PERIOD COVERED Final - July 1976- November 1979		
7. AUTHOR(s) Engineering Staff	6. PERFORMING ORG. REPORT NUMBER 79-5560-10		
	8. CONTRACT OR GRANT NUMBER(s) F33615-76-C-1135 ray		
9. PERFORMING ORGANIZATION NAME AND ADDRESS General Electric Company Aerospace Electronic Systems Department Utica, New York 13501	10. PROGRAM ELEMENT, PROJECT, TASK AREA & WORK UNIT NUMBERS 2004-06-05		
11. CONTROLLING OFFICE NAME AND ADDRESS Avionics Laboratory Air Force Wright Aeronautical Laboratories Air Force Systems Command Wright-Patterson Air Force Base, Ohio 45433	12. REPORT DATE November 1979		
	13. NUMBER OF PAGES 302		
14. MONITORING AGENCY NAME & ADDRESS (if different from Controlling Office) Final rept. Jul 76-Nov 79.	15. SECURITY CLASS. (of this report) UNCLASSIFIED		
	15a. DECLASSIFICATION/DOWNGRADING SCHEDULE N/A		
16. DISTRIBUTION STATEMENT (of this Report) Approved for public release; distribution unlimited			
17. DISTRIBUTION STATEMENT (of the abstract entered in Block 20, if different from Report)			
18. SUPPLEMENTARY NOTES			
19. KEY WORDS (Continue on reverse side if necessary and identify by block number) Common Aperture, Multi Spectral, Spectral Separator, Video Mix, Split Screen, Thermal Imager, Active/Passive TV, Silicon Vidicon Camera, Lead Vapor Illuminator, Laser Designator/Ranger			
20. ABSTRACT (Continue on reverse side if necessary and identify by block number) A multispectral optical imaging system was designed and fabricated to demonstrate the feasibility of utilizing a pointable common optical aperture in conjunction with interchangeable day or night TV sensors and a thermal imaging sensor. Limited processing capability was incorporated to permit mixing of both visible and infrared video of common scenes for more effective all weather electro-optical capability. An optical configuration was established which will accommodate image sensors as well as illuminating			

DD FORM 1 JAN 73 1473

EDITION OF 1 NOV 65 IS OBSOLETE

UNCLASSIFIED

SECURITY CLASSIFICATION OF THIS PAGE (When Data Entered)

402456 alb

UNCLASSIFIED

SECURITY CLASSIFICATION OF THIS PAGE(When Data Entered)

and designating/ranging lasers. In the early phases of the program various techniques were evaluated for optimizing spectral separation, gating image intensifiers and minimizing degradation of sensor performance due to insertion of .723 and 1.06 micron laser radiation through the common aperture. Preliminary testing indicates that combining sensors achieves synergistic performance in targeting and identification. Edited monthly R&D Status Reports detail the design, fabrication and integration aspects of the program.

Accession For	
NTIS GRA&I	<input checked="" type="checkbox"/>
DDC TAB	<input type="checkbox"/>
Unannounced	<input type="checkbox"/>
Justification	
By _____	
Distribution/	
Availability Codes	
Dist.	Avail and/or special
A	

UNCLASSIFIED

SECURITY CLASSIFICATION OF THIS PAGE(When Data Entered)

PREFACE

This technical report describes the work performed by General Electric Aerospace Electronic Systems Department, Utica, New York as part of the Common Aperture Techniques for Imaging Electro-Optical Sensors (CATIES) program under Contract F33615-76-C-1135.

The work reported herein was performed during the period July 1976 November 1979 by GE/AESD personnel. This final report describes the major milestones in the system development, the system capability and the final hardware configuration. Also included are measured performance data and the monthly R&D Status Reports for the entire program period. The monthly reports are sequential and are separated into three program phases: Phase I Critical Component Development, Phase II System Design and Phase III System Fabrication and Test.

TABLE OF CONTENTS

Section	Page
I INTRODUCTION	1
II PROGRAM DESCRIPTION	2
Phase 1 - Critical Component Study and Development	3
Phase 2 - System Design	5
Phase 3 - System Fabrication and Test	9
Final System Configuration and Features	10
III CONCLUSIONS	32
IV R&D STATUS REPORTS	40
Phase 1 Critical Component Development	41
Report No. 1	42
Report No. 2	46
Report No. 3	66
Report No. 4	70
Report No. 5	77
Report No. 6	82
Report No. 7	96
Reports No. 8 and 9	101
Report No. 10	104
Phase 2 System Design	107
Report No. 11	108
Report No. 12	110
Report No. 13	113
Report No. 14	115
Report No. 15	134
Report No. 16	139
Report No. 17	148
Report No. 18	157
Report No. 19	166
Phase 3 System Fabrication	177
Report No. 20	178
Report No. 21	182
Report No. 22	187
Report No. 23	216
Report No. 24	228
Report No. 25	236
Report No. 26	246
Report No. 27	275

TABLE OF CONTENTS (Continued)

Section		Page
IV	Report No. 28	280
Contd.	Report No. 29	281
	Report No. 30	283
	Report No. 31	284
	Report No. 32	286
	Report No. 33	296

LIST OF ILLUSTRATIONS

Figure	Title	Page
1	Results of CATIES Thermal Analysis on Spectral Separator	7
2	Temperature Profile in Germanium Mirror Less Than 0.0005 Inch	8
3	CATIES System	16
4	CATIES Major Equipment Components	17
5	Remote Control Console	21
6	Optical Paths	23
7	CATIES System Block Diagram	26
8	CATIES Multi-Spectral Imagery Wide Field of View	33
9	CATIES Multi-Spectral Imagery Narrow Field of View	34
10	Split Screen Display	36
11	Split Screen Display	37
12	CATIES Multi-Spectral Imagery	38
13	Control Console	184

LIST OF TABLES

Table	Title	Page
1	Major Component Characteristics	18

I. INTRODUCTION

Common Aperture Techniques for Imaging Electro-Optical Sensor (CATIES) equipment is supplied by General Electric Company, Aerospace Electronic Systems Department, Utica, New York, under Contract F33615-76-C-1135. The CATIES program objective was to design, fabricate, test, and deliver a low cost, multispectral electro-optical prototype system to demonstrate the feasibility of a single aperture concept. The final system optical design accommodates a Thermal Imaging Sensor (TIS), TV Camera, Laser Designator and Laser Illuminator. To minimize development costs Government Furnished Equipment (GFE) was used where practical. Also the TV cameras have been loaned by GE/AESD in support of a one year tower test program at Wright-Patterson Air Force Base.

During the design and development phase changes were made to the original CATIES concept. One change was required as an appropriate GaAs diode array laser illuminator was not available for incorporation into the CATIES system. However, under separate contract the Air Force was developing a discharge heated lead vapor laser which did not require cryogenics and offered acceptable power with a limited optics aperture. By modifying the existing study contract a working laboratory model was repackaged for use in the CATIES system.

As the program evolved two other changes were made which significantly modified the original concept. To improve limiting resolution and low scene contrast performance a silicon vidicon camera, directly interchangeable with the hybrid intensified night camera, was added for daylight use. The Air

Force Common Laser (AN/AAQ-25) was included in the electrical and optical design but due to funding limitations, system safety requirements during the testing phase and lack of long-term availability this laser was not physically incorporated into the system.

Final system level acceptance tests were conducted at the GE Cazenovia Antenna Test Range in September 1979. The system was then shipped to Wright-Patterson Air Force Base for tower integration.

Section II of this report summarizes the major milestones in the equipment development and describes the final equipment configuration. Section IV comprises the 33 monthly R&D Status Reports. These reports have been edited by removing non-technical related material (schedules and financial) as well as appendices which were subsequently altered and therefore no longer represented the final system.

II. PROGRAM DESCRIPTION

The goal of this program is to demonstrate through fabrication of a prototype the feasibility of a pointable multispectral common aperture electro-optical sensor system. The CATIES system provides a demonstratable technology for an integrated all weather day/night electro-optical sensor system in a cost effective package that can be employed in the early 1980s. Optical design trade-offs were made to obtain performance superior to that of either sensor alone and maintain a packaging configuration compatible with an 18-inch diameter pod.

For maximum flexibility special functions and controls were included. The relative merit of these functions will be determined during the system testing phase to be conducted by the Air Force. Limited electronic signal processing (split screen and video mix) was added to emphasize the sensor synergism that can be achieved by using a single multiple-spectral aperture.

The CATIES program consisted of three separate phases as shown below:

1. Critical Component Study and Development
2. System Design
3. System Fabrication and Test

Phase 1 - Critical Component Study and Development

During the study and development phase a baseline optical design compatible with an AN/AAQ-9 Honeywell Thermal Imager was established and sent to vendors for consideration. The initial layout is shown in the attachment to the R&D Status Report No. 4. A significant feature of this concept is the use of an axicon for integration of the laser energy into the optical path. This causes some loss of TV camera aperture, however, the resulting improvement in Modulation Transfer Function (MTF) due to complete isolation of the outgoing high energy beam makes this technique very attractive. In addition to minimizing veiling glare and vidicon raster burns in the TV path, this technique offers other advantages. When the diverging beam reaches the Spectral Separator and Pointing Mirror, energy is spread over a relatively large area. With coatings at these surfaces optimized for maximum

reflection, thermal gradients within the TIS aperture are minimized and no degradation in TIS performance occurs.

The second major investigation during this phase was the determination of the double gating requirements for the proposed hybrid intensifier for the night TV camera. Since the final optical design had not been firmly established at this point, the worst-case assumption that outgoing laser energy would not be isolated from incoming visible energy was evaluated. The double gating concept is described in detail in the attachment to R&D Status Report No. 2. Results of the evaluation are detailed in R&D Status Reports Nos. 4 through 7. Testing revealed that the on-off ratio attained by the second generation wafer tubes was more than adequate, making double gating unnecessary in the final design.

Sensor evaluation continued through Phase 1 and into Phase 2. Texas Instruments' and Honeywell's large aperture thermal imagers, as well as a Honeywell Mini Flir were evaluated for performance and ease of integration with the existing CATIES configuration concept. Also, during Phase 1 the Air Force agreed to the addition of an interchangeable silicon vidicon camera for improved system resolution and contrast performance during daylight operation. Three different illuminators were considered for the system prior to selection of the discharge heated vapor laser. Using this laser not only eliminates the need for cryogenics but also simplifies the optical design requirements for the insertion of its low divergence beam into the optical path.

Phase 2 - System Design

During the system design phase an optical design contract was awarded to Perkin Elmer of Norwalk, Connecticut. Several configurations were established and analyzed. Further evaluation of the two most promising techniques led to the final selection of a common objective with three turret mounted fixed focal length relays. Refinements and improvements were obtained in the overall system performance by making trade-offs in individual sensor performance and operating conditions. Mid-way through the design phase a preliminary design review was conducted which identified problem areas and examined potential alternatives.

Detailed mechanical and electrical drawings were prepared for the Remote Control Console, Interface Electronics Unit and the sensor package configuration. The Optical Bench, Pointing Mirror Assembly, Relay Turret and Camera Focus/Derotation Mount were also designed during this phase. A concept for the interface and mechanical integration of the lead vapor illuminator and optical assembly was established, but because of undefined key laser parameters (output beam diameter and divergence), final details were not determined until well into the fabrication phase of the program. A critical design review was held at the end of the design phase. The final system concept and range predictions for the TV and TIS sensors were presented. Permission was obtained from the Air Force to order long-lead items such as the console, connectors, and electrical components.

A computer thermal analysis was conducted on the critical spectral separator substrate to determine if any degradation in TIS performance would

result from heating effects of the laser. The assumptions made in this analysis are listed in Appendix 3 of R&D Status Report No. 14. The results were presented at the CATIES Preliminary Design Review of 30 November 1977 and are reproduced in Figures 1 and 2.

Progress made in the optical, electrical, and mechanical development up to the time of the critical design review is described in the R&D Status Reports Nos. 15 through 19. Anticipated fabrication costs of the complex optical assemblies were exceeding original estimates and the following actions were implemented.

1. Reduction in scope of the CATIES Program
 - a. Deletion of the LDR optical path
 - b. Deletion of two lead vapor illuminator optical paths
2. Solicit vendor quotes for comparison (see R&D Status Report No. 19)
3. Institution of a special program to monitor and control optical assembly development and fabrication which incorporated the following:
 - a. Utilization of optical consultants
 - b. Periodic design reviews to monitor progress and establish mechanical interfaces

	98% REFLECTANCE				90% REFLECTANCE			
	ILLUMIN		LASER D/R		ILLUMIN		LASER D/R	
	GERM	Z SEL	GERM	Z SEL	GERM	ZnSEL	GERM	ZnSEL
6.25 ID /6.50 OD ANNULUS	<0.05° C	<0.05° C	0.3° C	0.2° C	<0.05° C	<0.05° C	1.4° C	1.0° C
3" DIA SPOT	<0.05° C	<0.05° C	0.1° C	0.1° C	<0.05° C	<0.05° C	0.5° C	0.3° C
3/8" DIA SPOT	0.1° C	<0.05° C	6.2° C	4.4° C	0.3° C	0.2° C	31.2° C	21.9° C

MAXIMUM MIRROR SURFACE TEMPERATURE RISES

- TEMPERATURE RETURN TO INITIAL LEVEL DURING INTERPULSE PERIOD
 - LDR POWER - 0.20 JOULE PEAK
 - ILLUMINATOR POWER - 0.002 JOULE PEAK
- * PROFILE SHOWN ON NEXT SLIDE

Figure 1. Results of CATIES Thermal Analysis on Spectral Separator

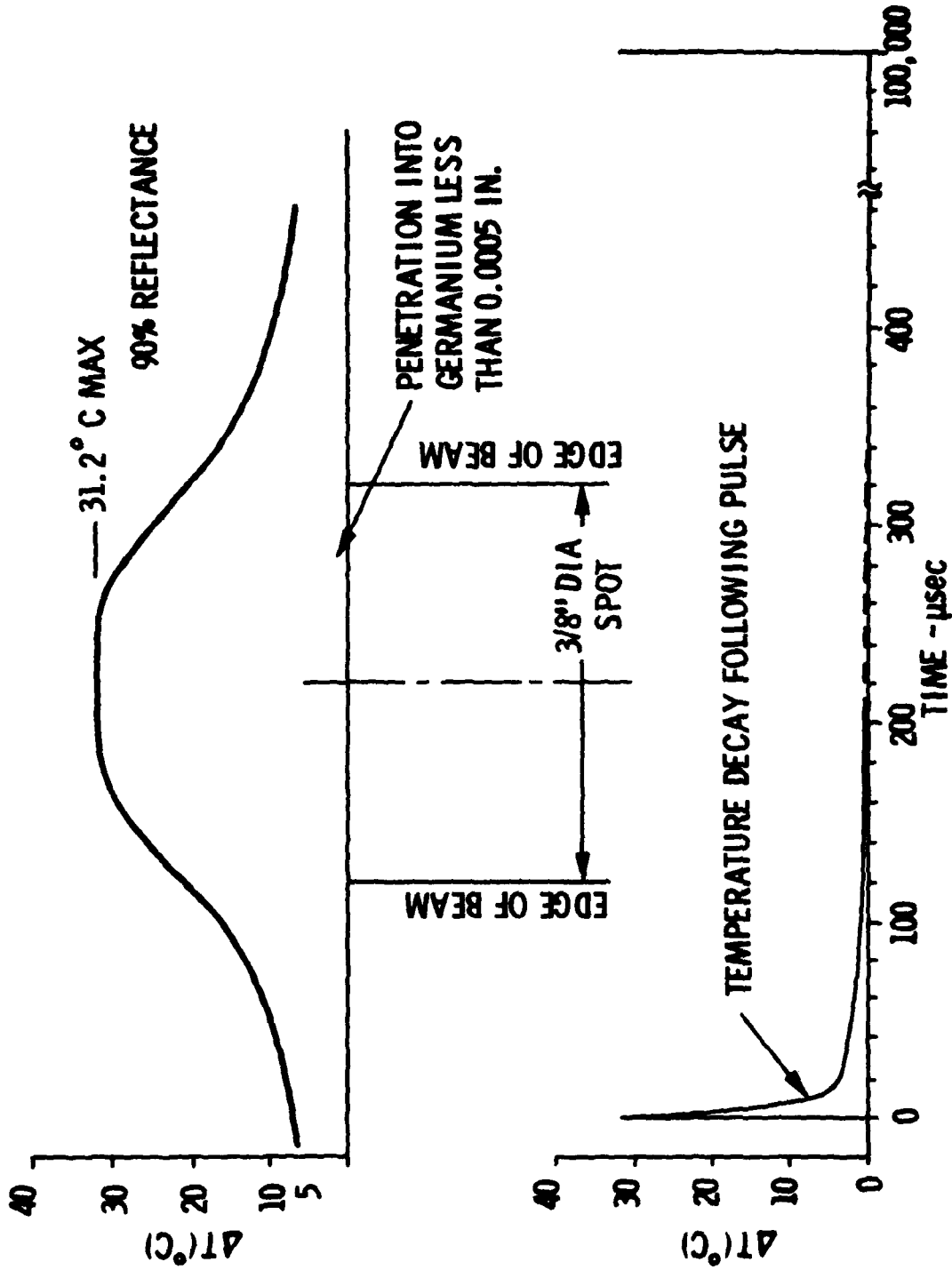

Figure 2. Temperature Profile in Germanium Mirror Less than 0.0005 Inch

Phase 3 - System Fabrication and Test

The duration of Phase 3 was greater than originally anticipated. Additional time was needed to obtain new quotes for the reduced scope optical designs. Also the installation of the three month control program for analysis of the existing design and establishment of the final detailed design added to the time requirements. Appendix A of R&D Status Report No. 22 is a Statement of Work which defines the tasks to be accomplished by the selected vendor (Alpha Optical). Approximately five months elapsed before a final optical design review could be held. See R&D Status Report No. 25. Fabrication of the optical assemblies did not begin until predicted system performance was established and reviewed.

A meeting was held at GE/SSL Valley Forge, Pennsylvania in July 1978 to establish a packaging concept for the lead vapor illuminator (GFE). See Appendix D of R&D Status Report No. 22. Uncertainties in illuminator parameters, such as raw output beam diameter and divergence, led to the design of a zoom lens for insertion of this beam into the optical path. The illuminator hardware was not delivered to GE/AESD until March 1979. Detailing mechanical interface drawings and fabrication of the support structure was performed concurrently with test and integration of the illuminator hardware.

The TIS (GFE) was received at GE/AESD in November 1978 and successfully operated with new cables and the TIS portion of the CATIES Remote Control Console. Video switching and display circuitry in the Interface Electronics Unit was successfully tested the following month. Acceptance testing of the TV related optical assemblies was performed at the vendor facility in May of

1979. The test data is shown in Appendix A of R&D Status Report No. 32. Final mechanical integration was completed and the system transported to the measurements lab at GE French Road, Utica for optical installation and alignment. The system was returned to GE Broad Street for parfocalization of the three relays and then in July transported to the GE Antenna Test Range at Cazenovia, New York. Final system level tests and Air Force Acceptance Tests were conducted at the test range. At the time of these tests a complete set of laboratory measured component level test data items, as listed in the Acceptance Test Plan Checklist, was supplied. Tests were conducted in accordance with the Acceptance Test Plan draft dated June 1979 and the data sheets are included in this section. In September 1979 the system was shipped to Wright-Patterson AFB for tower integration.

Final System Configuration and Features

The CATIES system is an integrated sensor package containing a thermal imaging receiver, a gateable low light level TV camera which is directly interchangeable with an unintensified silicon vidicon camera, and a discharge heated vapor laser illuminator. The optical and electrical design also accommodates a Nd Yag laser ranger which is not physically incorporated in the system at this time. All sensors employ a common, single, imaging aperture.

The CATIES system comprises three major assemblies (sensor assembly, remote control console and accessories associated with illuminator operation). See figure 3. Major equipment components are shown in figure 4 and their physical characteristics are summarized in table 1.

DATA SHEET
(Daylight Tests)

Sheet 1 of 2

Pointing Mirror Control

Date 9/6/79

Slew Rates

	Maximum rate attainable	Maximum rate with motor voltage adjusted for optimum sensitivity
Azimuth	$\frac{137}{2.1} = 65.2$ deg/sec	$\frac{136}{5.9} = 23.0$ deg/sec
Elevation	$\frac{18.6}{2.15} = 8.7$ deg/sec	$\frac{18.3}{7.55} = 2.4$ deg/sec
Lock Control operational	<input checked="" type="checkbox"/> yes	<input type="checkbox"/> no

Thermal Imager Controls

Operational yes no

Minimum focus distance < 10 feet WFOV

≈ 100 feet NFOV

Boresight between FOVs milliradians *Adverse weather → couldn't see site*

TV Camera Controls

Operational yes no

Minimum focus distance < 10 feet WFOV

150 feet NFOV

Boresight between FOVs ≈ 600 feet VNFOV

 milliradians WFOV to NFOV *couldn't measure*

.93 milliradians NFOV to VNFOV *9 ft at 9650'*

Image Display Controls

Operational yes no

Slaved FCV Controls

Operational yes no

Sweep Centering

Horizontal 4.5 milliradians

Vertical 3.1 milliradians

43' at 9650' range

30' at 9650' range

DATA SHEET
(Daylight Tests)

Sheet 2 of 2

Boresight Spot Source Visible

Camera yes no VNFOV
 yes no NFOV
 yes no WFOV
Thermal Imager yes no NFOV
 yes no WFOV

Accuracy of Azimuth and Elevation LED Displays

LED Display Readout	Actual
-2.5 degrees pinned	0 degrees
-66 degrees electrical limit left	TBD -60
+61.5 degrees electrical limit right	TBD +60
-96.5 degrees boresight position	-90
+15.8 Elevation	
Repeatability <input checked="" type="checkbox"/> yes <input type="checkbox"/> no VNFOV	
<input checked="" type="checkbox"/> yes <input type="checkbox"/> no NFOV	

Limiting Camera Resolution

>7238 TVL/Picture height VNFOV *saw all bars*
>720 TVL/Picture height NFOV *saw all bars*

Camera Interchangeability

Time to change over = 4 1/2 minutes

Daniel P. [Signature] GE/AESD

[Signature] Witness

Range to transmit site 9650ft

DATA SHEET
(Night Tests)

Sheet 1 of 2

FOV Match

Date 9/6/77

Azimuth milliradians
Elevation milliradians

*Super imposed
Video from TIS+TV to show FOV's matched*

Sweep Centering

Horizontal 9.8 milliradians
Vertical 2.8 milliradians

$\tan \theta = \frac{9.8}{9650}$
 $= \frac{2.8}{9650}$

Boresight Spot Source Visible

Camera yes no VNFOV
 yes no NFOV
 yes no WFOV

Laser Match to TV FOV

yes no VNFOV
 yes no NFOV

Noticeable change in TIS performance with Laser on in VNFOV

yes no NFOV
 yes no WFOV

Laser Controls

Operational yes no

Actual LED Readout

Distance to test site 2.94 km 2.95 km
Gating pulsewidth range .224 seconds minimum
6.24 seconds maximum

Output Laser Beam Uniformity

± % VNFOV *Took photos*
± % NFOV *NOT DETERMINED*

DATA SHEET
(Night Tests)

Sheet 2 of 2

Limiting Camera Resolution

Active

> 240 TVL/Picture height VNFOV
< 270 TVL/Picture height NFOV

≈ .9 watts output power

*all bars visible plainly
Intensifier EMI Masked*

Passive

___ TVL/Picture height VNFOV
___ TVL/Picture height NFOV

No Resolution bars visible in either fov.

Changing Filters in VNFOV

Active

useful
___ useful

not useful
 not useful

⁶⁶⁵
RG715
RG780

Passive (*overcast*)

useful
 useful
___ useful

not useful
 not useful
 not useful

⁶⁶⁵
RG715 *no diff. from 630*
RG780 *lower sensitivity*
RG1000

David Puthoff GE/AESD

JJ Altman Witness

CHECKLIST

Component Level Test Data

Date 9/6/79

Thermal Imaging Sensor

MRT curves

- 8 inch aperture ✓
- 6.5 inch aperture and pointing mirror ✓
- 6.5 inch aperture, pointing mirror and spectral separator ✓

Daylight Camera

- Limiting center resolution ✓
- Limiting corner resolution ✓
- Critical voltages ✓

Intensified Camera

Performance curves

- Resolution - sensitivity ✓
- Squarewave amplitude response ✓
- Critical voltages ✓
- Gate pulsewidth range ✓

Lead Vapor Illuminator

- Copy of start-up procedure ✓
- Actual discharge voltage vs PS reading ✓
- Maximum rawbeam power output ✓
- Laser power output ✓

Pointing Mirror and Drive Assembly

- Mirror flatness ✓
- Coating reflectance ✓
- Az and El extremes with joystick control ✓

Hydraulic Lift Cart

- Optical line of sight distance above floor (min, max) ✓
- Total time (ascent, descent) ✓
- Average ascent descent rates ✓

Subcontracted Item Data

- Alpha Optical Acceptance Test Data ✓
- Measured MTF Data (all FOV's) ✓
- Element Coating Characteristic Curves ✓
- Spectral Separator Interferograms ✓
- Reflectance and Transmission Curves for Spectral Separator ✓

David R. Cook

GE/AESD

J. J. [Signature]

Witness

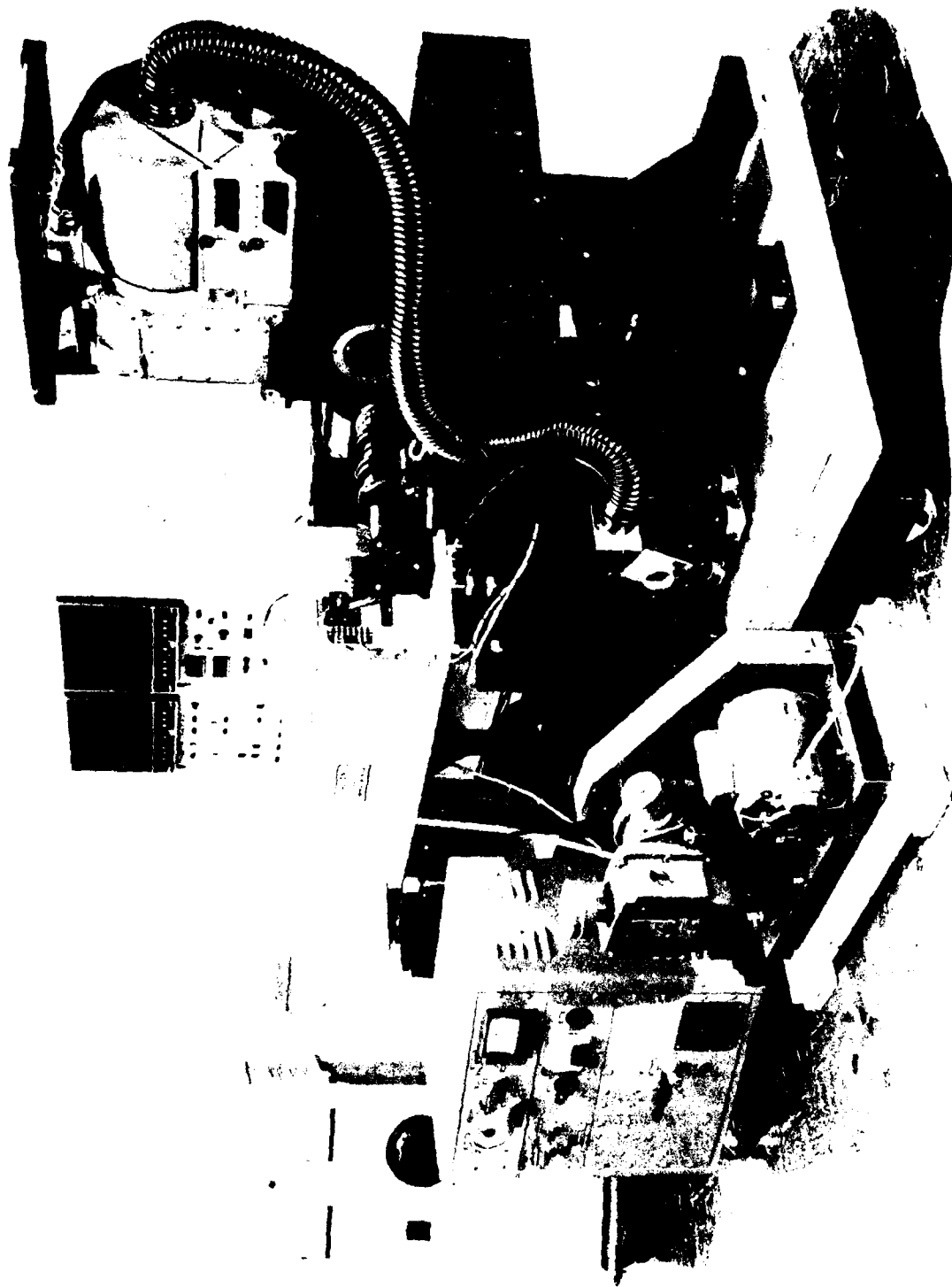

Figure 3. CATIES System

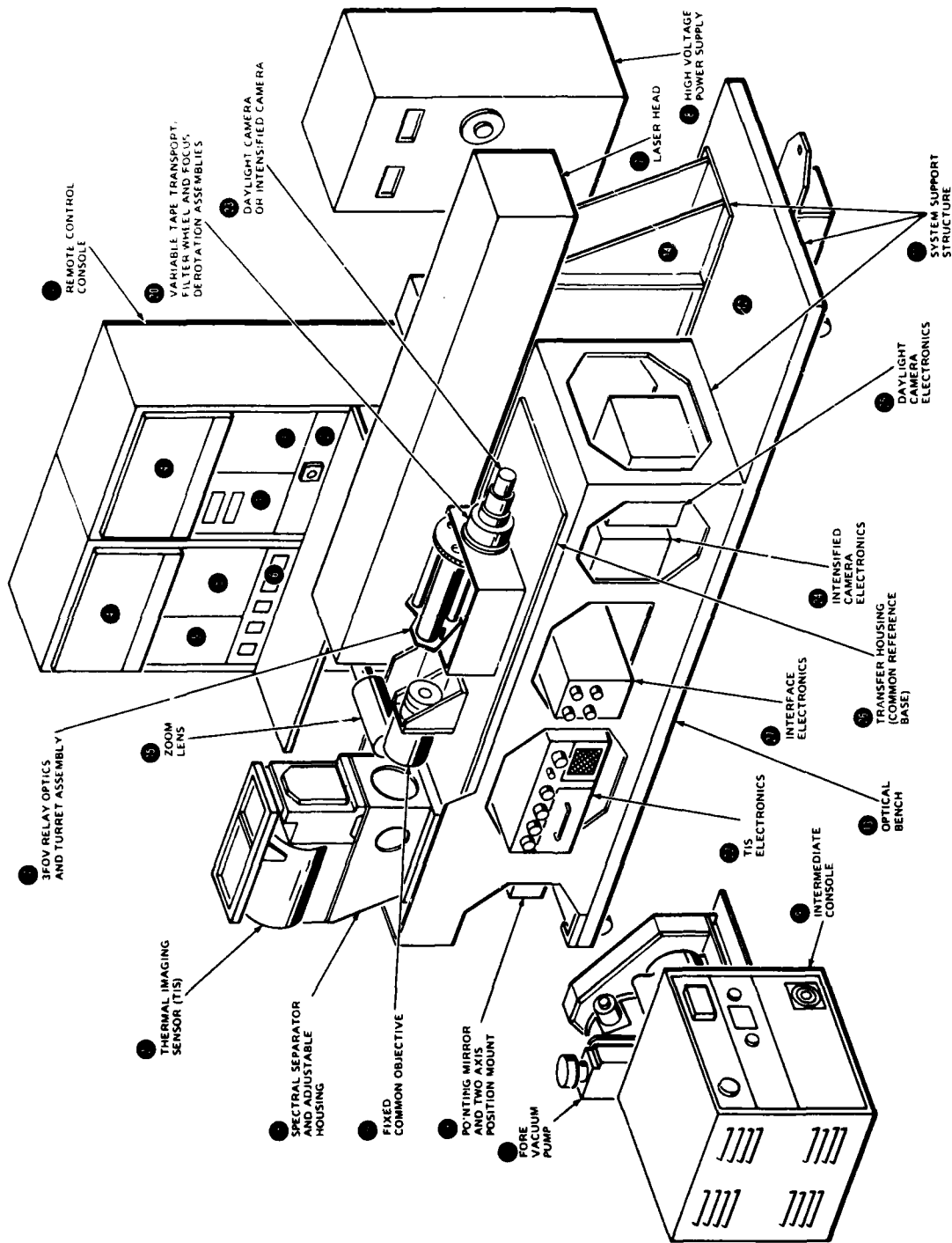

Figure 4. CATIES Major Equipment Components

Table 1. Major Component Characteristics

Name	Wt. Lb.	Dimensions (Inches)			Input Power Requirements	Location on Figure 1-2.	Drawing Number
		Length	Width	Height			
Remote Control Console	250	22.0	42.0	59.0	-	1	7936528
● Pointing Mirror Console		2.5	19.0	4.0	28 VDC	2	7961935
1 ● System/TV Cameras		14.6	19.0	12.2	-	3	7936522
● CONRAC Monitors (2)		24.0	19.0	14.0	110 VAC/60 Hz	4	GFE
● LDR/TIS		14.5	19.0	12.2	-	5	7936523
● Circuit Breaker		12.0	19.0	4.0	-	6	7936527
Lead Vapor Illuminator	110	69.0	10.0	10.8		7 thru 10	
● Laser Head						7	GFE
● High Voltage Power Supply		18.0	18.0	36.5	230 VAC 2 60 Hz	8	GFE
● Intermediate Console		14.5	22.0	2.5	110 VAC/60 Hz	9	GFE
● Fore Vacuum Pump		28.0	16.5	20.5	110 VAC/60 Hz	10	GFE
System Support Structure	1350	89.5	36.0	56.7	110 VAC/60 Hz	11	--
● Hydraulic Lift Base						12	Southworth Owner's Manual
● Optical Bench	150	70.5	24.5	22 (max)	-	13	7936540
● Adjustable Illuminator Mount	50	65.3	10.0	16.5	-	14	7961922
Optical Assembly	5	15.0	6.0	4.5	28 VDC	15 thru 20	--
● Zoom Lens		12.5	7.6	7.6	-	15	7961928
● Common Objective		14.5	13.5	10.0	28 VDC	16	--
● 3 FOV Relay Optics & Turret Assembly	25					17	
● Spectral Separator	15	22.0	13.1	11.3	-	18	7936542
● Pointing Mirror Assembly	18	15.0	15.0	12.2	28 VDC	19	7936541

Table 1. Major Component Characteristics (Continued)

Name	Wt. Lb.	Dimensions (Inches)			Input Power Requirements	Location on Figure 1-2.	Drawing Number
		Length	Width	Height			
Optical Assembly (Cont) • Variable ND Tape Transport/ Filter Wheel and Focus/ Derotation Mount • Transfer Housing	10 40	5.0 43.0	9.7 14.2	7.5 0.7	28 VDC -	20 26	7936546
Thermal Imaging Sensor • Scanner Assembly • Electronic Unit	80 40	21.5 11.0	10.5 13.0	15.5 7.2	115 VAC/3 /400Hz	21 21 22	GFE
Intensified Camera • Camera Head • Electronics Unit		9.5	3.2 6.5	3.2 7.2	28VDC, 1A	23 23 24	7936547 * *
Daylight Camera • Camera Head • Electronics Unit	1 6	7.7 9.5	3.2 6.5	3.2 7.2	28VDC, 1A	23 23 25	7936547 * *
Interface Electronics	6	13.7	8.0	9.0	28VDC, 1A	27	7936548

*On loan from GE/AESD

The sensor assembly mechanically and electrically integrates the Thermal Imaging Sensor (TIS), Daylight Silicon Vidicon Camera,* interchangeable Intensified Camera* and the Lead Vapor Illuminator. The assembly includes an optical bench with a common reference plane (Transfer Housing) for the objective, relay optics turret and cameras.

The front of the optical bench contains the azimuth gimbal and elevation drive mechanism for the Pointing Mirror, it also supports the Spectral Separator and Thermal Imaging Sensor. The electronic units are mounted in the lower part of the optical bench. The Lead Vapor Illuminator is supported independently on its own adjustable mount which is laterally attached to the optical bench providing rigidity and maintaining boresight. Vertical adjustment of the system optical line of sight, over a range of approximately four feet, is achieved by mounting the equipment described above on a commercially available 2000 pound capacity, motor driven hydraulic lift table.

The Remote-Control Console (see figure 5) can be located up to 40 feet away from the sensor assembly. In addition to two 14 inch CONRAC monitor display units the console contains controls to activate and operate the Thermal Imaging Sensor, both TV Cameras, the Pointing Mirror and video processing. Controls are also provided to interface with a Nd Yag AN/AVQ-25 laser rangefinder, not incorporated into the CATIES system at this time.

*On loan from GE/AESD

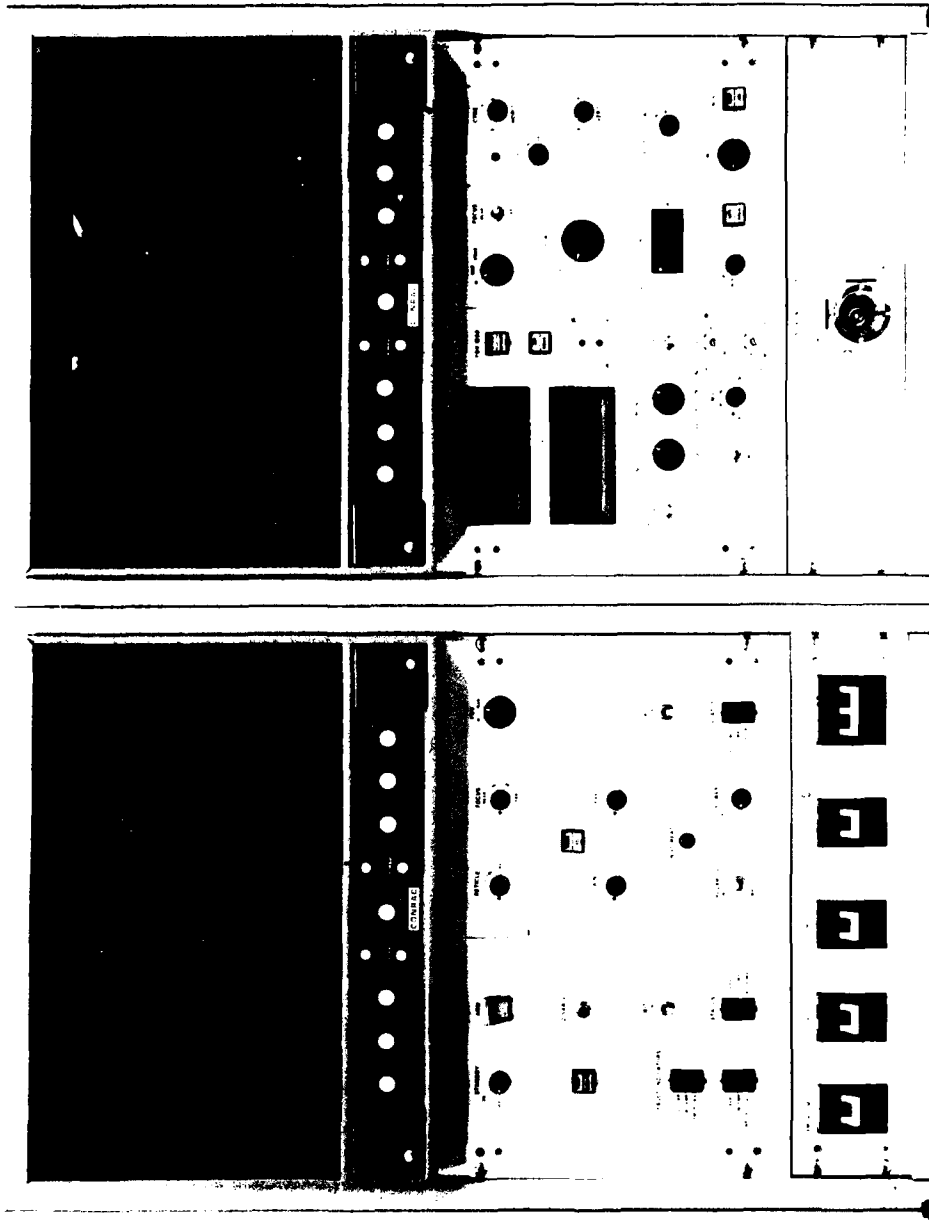

Figure 5. Remote Control Console

Additional free-standing accessories associated with illuminator operation include a vacuum pump, intermediate illuminator control console, five-kilowatt dc power supply, helium source, and interconnecting cables.

Optical Paths

Figure 6 illustrates the optical layout of the CATIES system including the assemblies and elements required to accommodate the Laser Designator Ranger. Light from the scene enters the system at the pointing mirror. The mirror is remotely adjustable in azimuth and elevation from the control console. Visible and infrared energy are reflected by the pointing mirror to the germanium Spectral Separator. Infrared energy (8 to 14 micron) is transmitted through the separator and a 6.5 inch aperture to the Thermal Imaging Sensor (TIS). The scanner assembly with two field of view integral optics and related electronics unit is GFE and is described in detail in the Operation and Maintenance Instructions for AN/AAQ-9 (XA-2) Infrared Detecting Set.

Energy at the 0.6 to 0.9 and 1.06 micron wavelength is reflected by the Spectral Separator to the Common Objective assembly. The last element of the objective (field flattener) is physically located in the relay turret housing. Three fixed field of view relays are mounted in separate cylindrical housings which interface with the turret mechanism. After passing through the objective and selected FOV relay the light passes through one of four selectable spectral filters and an automatically adjusted neutral density tape-transport. This assembly controls the spectral distribution and amount of light entering the TV Camera.

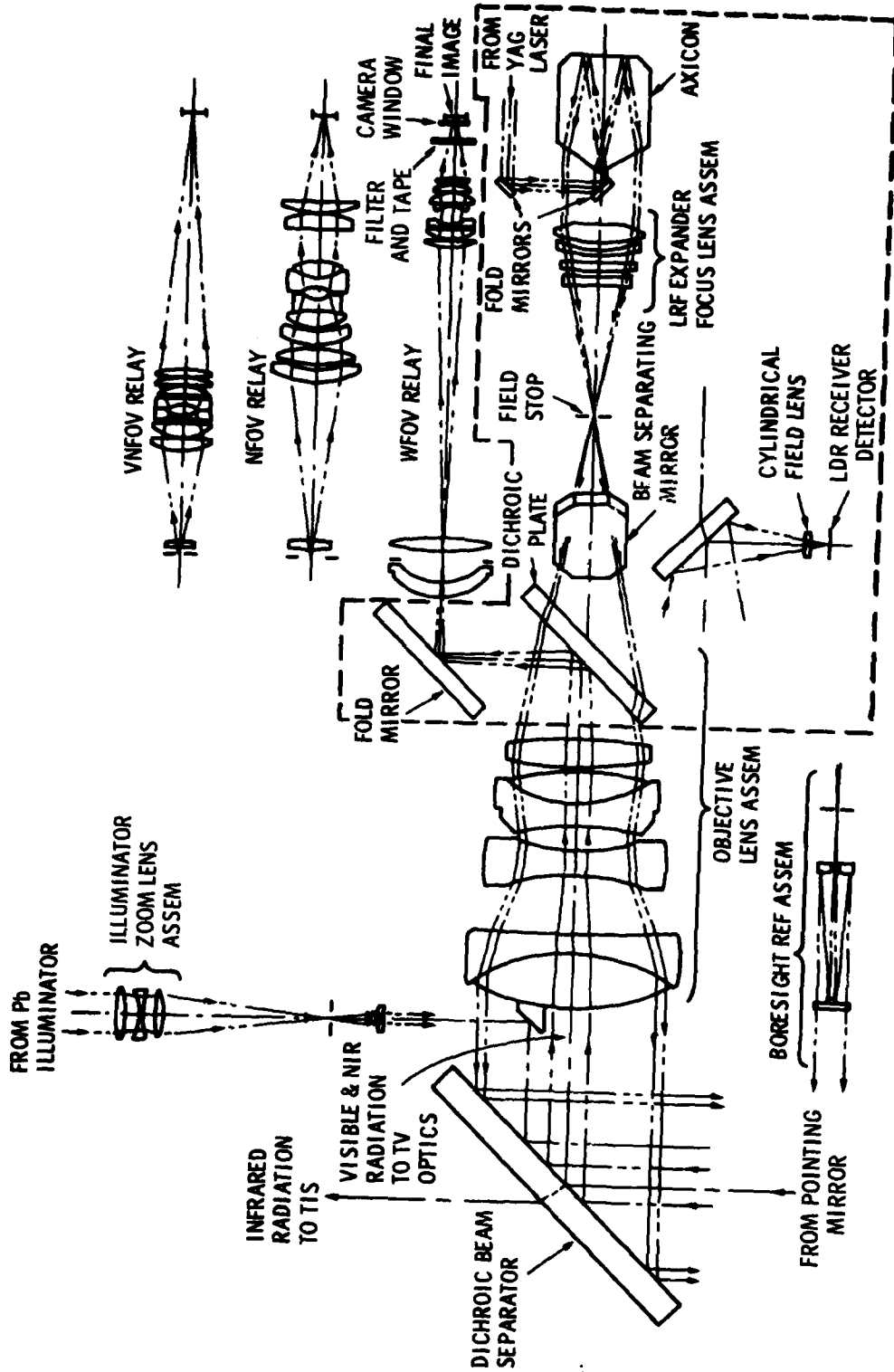

Figure 6. Optical Paths

Outgoing energy from the Lead Vapor Illuminator is deflected 90° into the Zoom Lens. The Zoom Lens assembly consists of five optical elements including two doublets which are automatically driven to predetermined locations to match the Intensified Camera selected field of view. A turning mirror mounted on the objective housing inserts the laser beam into the optical path. This outgoing beam is reflected by the Spectral Separator to the Pointing Mirror and out to the scene being viewed by the TIS and TV sensors.

Light energy produced by a bulb and projected on a pin-hole aperture is collimated by the reference boresight assembly. The Pointing Mirror is directed into this assembly by the boresight command from the console. The light is then viewed by the TV camera to verify boresight between the three fields of view. The collimated light is in focus in all three TV fields of view and the intensity can be varied by controlling the bulb voltage.

The image plane of the collimator is at the pin hole location. A glass with a conductive coating located close to but thermally isolated from the aperture plate permits the image to be seen by the TIS. The coating heats up by absorbing infrared energy. This provides a thermal gradient at the pin hole aperture location.

The remainder of the optics, designed for Nd Yag Laser beam insertion, although not incorporated in the system at this time function as follows.

Outgoing 1.06 micron laser-energy is reflected by mirrors to the point of a refractive axicon. The energy is formed into an annular ring which is projected with an expander to the back outer edge of the Common Objective. There is an unused region or "dead zone" near the outer edge of the Common

Objective. This zone is used for complete separation of the 1.06 micron outgoing energy from the large area central portion which collects visible energy for the TV sensors. After passing through the objective the outgoing energy then strikes the Spectral Separator and Pointing Mirror within the 6.5 inch diameter clear aperture used for the TIS. The large annular area over which the outgoing laser energy is distributed and the high quality reflectance characteristics of the coatings results in a minimal heat rise at these surfaces. These effects are not detected by the TIS detectors and therefore result in no degradation in TIS performance.

The LDR receiver collects the return 1.06 micron energy reflected by the target. After being collected by the objective visible energy for the TV camera will be reflected by the first dichroic plate to a second turning mirror into the relay assembly. The 1.06 micron energy transmitted by this plate strikes the highly reflective central portion of the beam separating mirror which directs the energy into the receiver detector. The clear outer portion of this element does not attenuate the annular outgoing laser beam on its way to the objective.

Electrical Functions - The electronic circuitry required for system operation is illustrated in figure 7, the functional block diagram, and is described in the following paragraphs.

The Pointing Mirror is mounted in a frame assembly which is motor driven in azimuth and elevation. Reference potentiometers are used in each axis to provide dc voltages proportional to the optical line of sight

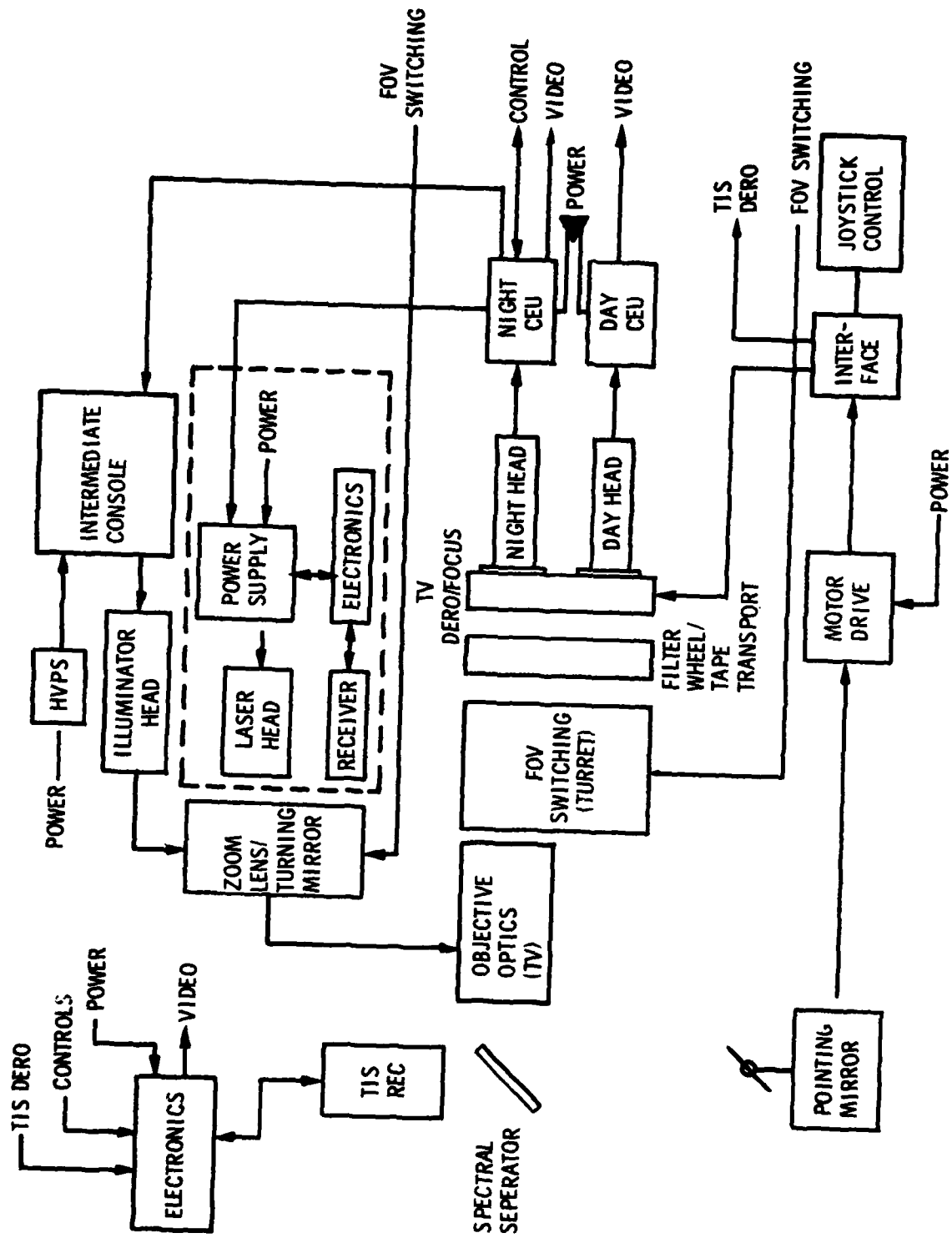

Figure 7. CATIES System Block Diagram

displacement. The azimuth voltage is used to derive the TIS and TV camera derotation commands. Feedback for the servo electronics and LED readout display signals are also obtained from these reference potentiometer voltages.

The motor drive circuitry and servo electronics for the pointing mirror, relay turret and zoom lens are housed in the Interface Electronics Unit (IEU). Electrical interfaces for the Remote Control Console functions (joystick, azimuth and elevation LED readouts) are also contained in this unit.

The IEU also generates position signals for the TV camera filter wheel, neutral density tape transport (for light control) and focus assembly. Circuits for synchronizing system sensors and video processing for split screen or video mix presentations at the console are also provided.

The 28 VDC power originates in the console and is routed to the IEU for distribution to the TIS and TV camera being used. Control functions to operate the Silicon Vidicon Camera or the Intensified Camera are also routed from the control console to these sensors via the IEU. TIS control interface is made directly between the TIS Electronics and the Remote Control Console.

Lead Vapor Illuminator - Fields of view for the Lead Vapor Illuminator and camera are selected concurrently with the FOV control on the TV CAMERAS panel in the console. Logic circuitry and motor drive circuits in the IEU control the desired mechanical operations in the relay turret and zoom-lens assemblies. The illuminator READY signal and the shutter (LASE) command are also processed in the IEU.

Activation of the Lead Vapor Illuminator (see instruction manual for Discharge-Heated Lead Vapor Laser System F33615-77-C-1078) requires, in addition to operation of the High Voltage Power Supply, monitoring and adjusting the helium buffer gas pressure and thyatron grid voltage at the Intermediate Console. Trigger pulses for firing the laser originate in the Intensified Camera Electronics Unit. The delay between the illuminator pulse and the intensifier gate pulse is derived automatically by sensing TV video in the camera range board or selecting the range manually at the Remote Control Console.

Sensors -

Honeywell 6.5 inch aperture Thermal Imaging Sensor (TIS)

Two fields of view matched to TV (can be 55 mr and 210 mr
slaved or changed independently).

Automatic derotation

Electronic reticle crosshair

Variable intensity

Polarity

White hot/white cold

Built in gray scale generator

Remote focus

Other controls

Gain/Level

Silicon Vidicon TV Camera

Three fields of view matched to TIS	20, 55 and 210 mr
Automatic derotation	
Electronic reticle crosshair	
Horizontal and vertical sweeps (remotely adjustable)	Centering and boresight
Automatic light control	Tape transport
Spectral filter wheel	RG630, RG665, RG780, RG1000
Shutter	Remotely activated
Remote focus	
Built in gray scale generator	

Intensified TV Camera

Three fields of view matched to TIS	20, 55 and 210 mr.
Automatic derotation	
Electronic reticle crosshair	
Horizontal and vertical sweeps (remotely adjustable)	Centering and boresight

Automatic light control	Tape transport
Spectral filter wheel	RG630, RG665, RG780, RG1000
Shutter	Remotely activated
Remote focus	
Built in gray scale generator	
Active or passive operation	
Illuminator source	Lead vapor (PbV) 723 nm
Horizontal field of view	16 and 48 mr
Variable intensifier gate width range	0.22 us to 6.2 us
Range	Delay adjustable

Pointing Mirror (unstabilized)

Field of regard	Azimuth $\pm 60^\circ$ Elevation $+4^\circ$ to -10°
Operating Modes	
Lock	Azimuth and Elevation motor drives deactivated
Manual	Joystick operation

Calibration

Remote variable intensity
source visible to TV and
TIS sensors

Display Features

Independent TV and TIS monitors

525 TVL, 3 x 4 aspect

Split screen TV and TIS

Side by side

Registered video

Ratio of mixture

TV and TIS Variable
(0 to 100%)

Offset out/in

1 us horizontal shift of
video

Blanked monitor scan (needed, due
to excessive TIS distortion)

Vertical

Top and bottom 50 lines
in each active frame

Horizontal

First and last 5.5 us of
active scan or none

III. CONCLUSIONS

The CATIES system is installed at the Wright-Patterson AFB to begin a one year extensive test under varying weather conditions. Results of these tests will indicate the relative utility of each of the sensors and thereby contribute to the concept for a flyable multispectral system design.

The following information was obtained during preliminary testing of the CATIES system in the GE/AESD laboratory and at the GE Cazenovia Antenna Test Range. This information is provided as a starting point for obtaining optimum sensor performance during the system testing at Wright-Patterson Air Force Base. This information also describes preferred modes of operation which merit further evaluation. Most of the testing was performed using the silicon vidicon daylight camera but it is assumed that the information obtained will be valid for night operation also.

Varying the display modes (SPLIT, MXT or separate video) for specific operating conditions can significantly enhance system performance. Specific examples are listed below.

1. The TV camera, because of its greater resolution, provides superior terrain and contour information (for navigation and locating landmarks). The TIS emphasized man-made structures (targets), see figures 8 and 9, and was used more frequently during low humidity conditions for directing the pointing mirror to targets of interest.



8 TO 14 MICRON THERMAL IMAGER



0.7 TO 0.9 MICRON TV

Figure 8. CATIES Multi-Spectral Imagery Wide Field of View



0.7 TO 0.9 MICRON TV

8 TO 14 MICRON THERMAL IMAGER

Figure 9. CATIES Multi-Spectral Imagery Narrow Field of View

2. The split screen function was originally intended for simultaneous display of identical scenes from two sensors. A more useful method is to operate the TV with a narrower FOV than the TIS as shown in figures 10 and 11. In this mode the TIS is used for detection of targets while the narrower view of the TV provides information for identification.
3. With both sensors functioning optimally (clear, low humidity conditions), separate presentations of the same scene often appeared very different (see figure 12). Under these conditions the video mix display mode is most effective.
4. Distortion of the TIS presentation is evident in the MXT mode operation even with blanking of the outer edges of the display. For large area coverage or processing over the full sensor field of view some distortion correction (or insertion into the TV camera) will be required.

Under virtually all weather conditions, when operating the silicon vidicon camera the RG-780 filter produced better picture contrast. Little change was detectable with the other filters. Therefore, the complexity of multiple filters is not warranted if the silicon vidicon camera is to be the only sensor.

A zoom lens was used in place of fixed focal length relays, originally planned, for matching the illuminator FOV to the TV camera FOV. This decision was necessary as the illuminator raw beam diameter and divergence characteristics were unknown until this GFE item was actually received. The



NARROW FIELD OF VIEW TV



WIDE FIELD OF VIEW THERMAL IMAGER

Figure 10. Split Screen Display



NARROW FIELD
OF VIEW THERMAL IMAGER



VERY NARROW FIELD
OF VIEW TV

Figure 11. Split Screen Display



0.7 TO 0.9 MICRON TV

8 TO 14 MICRON THERMAL IMAGER

Figure 12. CATIES Multi-Spectral Imagery

zoom lens switching time is very slow (30 seconds) and the transmission losses (approximately 25 percent) are too high for this technique to be used in any future system. For the prototype system the zoom lens provided the flexibility necessary to minimize fabrication delays.

The size of the spectral separator is established by the clear aperture required for reasonable performance of the TIS (GFE) and the optimum optical configuration selected. The raw material and fabrication cost of the one inch thick germanium substrate was very high. Therefore in future systems reducing the clear aperture by using a Mini FLIR or changing the operating spectrum of 8 to 14 microns to 3 to 5 microns should be considered.

The delivered system permits side by side comparison of IR and TV sensor video while looking at a common scene with multiple, matched or independently selectable fields of view. As the test program continues these comparisons will be made under various weather and atmospheric conditions. In many instances the displayed video from each sensor did not appear to be from the same scene until specific features were identified or the images were superimposed on one display. Limited signal processing has been incorporated in the system to combine the information from each sensor in a single display. Additional signal processing techniques will be required for improved target detection and display enhancement.

Figures 8 through 12 are photographs taken from a video tape monitor display of actual daylight scenes at the GE Cazenovia Antenna Test Range. The targets shown were from 1 to 3 kilometers distant. Figure 8 shows each sensor operating independently in the widest field of view (12°). A house is

shown in figure 9 with both sensors operating with the narrow field of view optics (3°) and being displayed in the split screen mode. A close range target is shown in figure 10 using the 12° field of view for the TIS and the 3° field of view for the TV. The display is in the split screen mode. The same scene is shown in figure 12 with the sensors operating with matched fields of view. Figure 11 shows the antenna transmit site, approximately 3 kilometer range through the 3° field of view optics for the TIS and the 1.14° optics for the TV camera.

IV. MONTHLY R&D STATUS REPORTS

This section contains all 33 R&D Status Reports provided to the Air Force during the three phases of the CATIES Program. The reports have been edited to delete scheduling, financial status and other data not related to hardware development or performance. The reports are sequential and are separated into the three program phases.

R&D STATUS REPORTS

No. 1 through No. 10

PHASE I

CRITICAL COMPONENT DEVELOPMENT

July 1976 through May 1977

R&D STATUS REPORT NO. 1

I. GENERAL

This initial research and development status report describes the activities of the General Electric Company in the development of the Common Aperture Techniques for Imaging Electro-Optical Sensor (CATIES) Program under Contract F33615-76-C-1135, Item No. 0002, CDRL Sequence No. 2.

Due to receipt date of contract and annual vacation shutdown at General Electric, AESD, work performed on the CATIES program was limited to program organization and preliminary financial planning. The program schedule had been submitted previously and is therefore not included in this report.

II. ORGANIZATION

Program personnel have been assigned as follows:

Program Manager	Paul Tracy Avionics Programs
Engineering Manager	Anthony Carpentier Night Attack Systems Engineering Unit
Project Engineer	Louis Lego
Contributors - Phase I Image Tube Gating Evaluation	James Julliano
Materials and Coating Evaluation	Charles Moy
Optical Consultant on Optical System Specification	Donald Kienholtz

These key contributors will be assisted as required by specialists and technicians from the Engineering Unit.

III. INITIAL MEETING

The CATIES kickoff meeting was held August 4, 1976 at the Air Force Avionics Laboratory. Attendees were as follows:
General Electric: Anthony Carpentier, Harry Dolson, Loren Ford, Louis Lego; Avionics Laboratory: Donald Learish, Ron Hubbard.

The program schedule was reviewed and personnel assignments were discussed. Donald Learish requested that a program charge record showing planned and actual charges to date be included in the monthly R and D Status Report. This charge status was not prepared in time for this report but will be forwarded as soon as it is available. A weekly phone contact was also requested between Donald Learish and Louis Lego.

IV. TECHNICAL DISCUSSION

Topics discussed are summarized below:

A. Image Gating

A copy of our double gating evaluation plan was requested by the end of August for Donald Learish.

B. CATIES Illuminator Selection

General Electric expressed concern regarding the amount of radiated beam power (4.9 watts) which could be achieved with a standard GLINT gallium arsenide illuminator, and the 2.7 inch aperture obscuration required to achieve this power in the beam. Several alternatives were discussed.

1. Use of high radiance Grumman illuminator. This would provide approximately 5 times more beam power at the expense of greater maintainability problems, and 3 to 5 times higher liquid nitrogen consumption.

2. Development of gating wheel as described in GE proposal, but not costed in CATIES program. This would permit use of the full CATIES aperture for both camera and illuminator, and would provide field of view switching for both with only a single mechanism. It was suggested that GE prepare a brief paper showing the cost delta involved in utilizing this technique and eliminating double gating and multiple gating supply requirements.
3. Use of the General Electric room temperature metal vapor laser to replace the cooled gallium arsenide (Ga As) diode array as planned. Four effects of the illuminator are: reduced aperture obscuration, elimination of cryogenics requirements, provision for multiple wavelength 0.72 micron or 0.53 micron capability, and lower production cost. The following disadvantages were discussed: greater initial technical risk, lower contrast of some tactical targets at 0.72 microns, and lower covertness. Power levels in the 3 degree field of view would be 3 to 5 watts near term.

A final decision on illuminator selection will be delayed until the Avionics Laboratory has discussed the metal vapor laser with Dr. Ronald Paulson of the AFAL Laser/Sources Group, and the internal GE development plan had been determined. A decision should be made by August 16 to avoid delays of other program tasks.

C. PERFORMANCE MODELING

Donald Learish asked that we determine the possibility of transferring our active TV and FLIR computer models to the AFAL computers for his use. This will be investigated.

D. DAYLIGHT TELEVISION CAMERA

The possibility of adding a daylight camera head to the system was discussed. This would result in about a 2 times resolution improvement in daylight operation, and would reduce

the costs and performance degradation associated with filtering a night camera. GE will determine the cost difference involved in using the daylight camera and submit this information to AFAL for review.

V. SUMMARY

During the next reporting period, work will be initiated on the gating evaluation, coating investigation and subsystem specifications.

R&D STATUS REPORT NO. 2

I. GENERAL

This second research and development status report describes the activities of GE/AESD in the development of the Common Aperture Techniques for Imaging Electro-Optical Sensor (CATIES) Program under Contract F33615-76-C-1135, Item No. 0002, CDRL Sequence No. 2.

II. GATING STUDY

During this reporting period, the two image intensifiers were specified and ordered. These intensifiers will be used during the double gating tests and later on the night camera head. The 18 mm 1st generation device was ordered from RCA, and the second generation wafer was ordered from ITT. Prior to being coupled and potted, the intensifiers will be tested separately. The assembled unit will then be tested with and without the coupled television camera tube. A detailed test plan including the gating technique for evaluation of the image intensifiers has been prepared and is an attachment to this report.

The gating power supplies to be used in the test program have been tested and aligned. Work has been started on checkout and calibration of the intensifier evaluation equipment.

III. SYSTEM CONFIGURATION

Active Television (ATV) Illuminator - Notification was received during this period of the Air Force intent to furnish the Grumman High Radiance Gallium Arsenide (Ga As) Illuminator. GE/AESD is presently attempting to get optics design information on this illuminator from Grumman.

IV. FORWARD LOOKING INFRARED (FLIR) DETECTOR SET

Selection of the FLIR to be used in the CATIES system has not been made. GE/AESD requested specific information from AFAL on the optics design of each of the AN/AAQ-9 FLIR's being considered. This information is needed as soon as possible so that work can proceed on the optics system configuration and specification.

V. OPTICS

Several configuration modifications are being evaluated to the proposed all dedicated optics scheme. One involves a method of injecting the ATV illuminator into the visible/near infrared (NIR) channel without the use of central or decentered obscuration. In this scheme, the illuminator energy is introduced in a 0.4" ring on the outside of the visible/NIR objective lens. This reduces the f/number of this objective lens by the same amount as caused by an equal area central obscuration, but does not produce the same wavefront distortion effected by central obscuration. Thus the modulation transfer function (MTF) of the visible/NIR optical chain should be improved.

Other schemes to reduce the number of lens changers required for field of view (FOV) switches are also being evaluated.

VI. IR BAND SHIFT CONSIDERATIONS

On September 4, GE/AESD was notified by the project office that a wave band shift of the IR from 8-14 microns to a 3-5 micron band was being considered. GE/AESD was asked to evaluate the impact of this shift on the CATIES system design. This evaluation is in progress, and initial results indicate that with the all dedicated optics approach pursued by GE/AESD, the impact is minimal, effecting primarily the window, and beamsplitter. With the alternative common objective approach presented in the GE/AESD proposal, the change is drastic with considerable simplification resulting due to the optical materials available for the 3-5 micron band. It would appear that

a reconsideration of the common objective design would be appropriate if this wave band switch is made.

VII. SUMMARY

In summary, progress is being made in both the gating study and the system configuration and specification. A need exists for optics design data on the ATV illuminator and the IR system/systems being considered. Attempts to obtain this information are proceeding through the vendors and the AFAL project office. Data is also needed on the laser designator/ranger to be furnished, but this data is not presently limiting progress.

ATTACHMENT TO STATUS REPORT NO. 2
DETAILED TEST PLAN

SCOPE

This test plan outlines the procedures and equations to be used in a feasibility evaluation of a double gated, hybrid, image intensifier. The evaluation is to assess the ability of this intensifier configuration to obtain a high rejection of unwanted, backscattered energy. As part of the evaluation, measurements are performed in accordance with the procedures outlined in this test plan. Through-out this evaluation, the measurement results are compared to theoretical predictions. These comparisons as well as the measured results are used to assess the feasibility of double gated, hybrid, image intensifier to reject unwanted, backscattered energy. (Figure 1 shows the feasibility evaluation test flow cycle.)

BACKGROUND

The aspect of range gated active television which is most significant in terms of performance enhancement is that of "gating out" scattered light. This unwanted scattered light comes from natural sources as well as from the illuminator. Of the two, scattered light from the illuminator is of most concern. Prior to the advent of common aperture active television, rejection of unwanted scattered light from the illuminator could be achieved with standard gating technology. In a common aperture active television, however, conventional gating techniques which were acceptable previously are now clearly unacceptable.

In a common aperture active television, high rejection of unwanted, scattered light from the illuminator is critical for system performance. One concept to obtain high rejection capability is a double gated, hybrid, image intensifier. This concept uses multiple, gated intensifiers to achieve a high rejection capability.

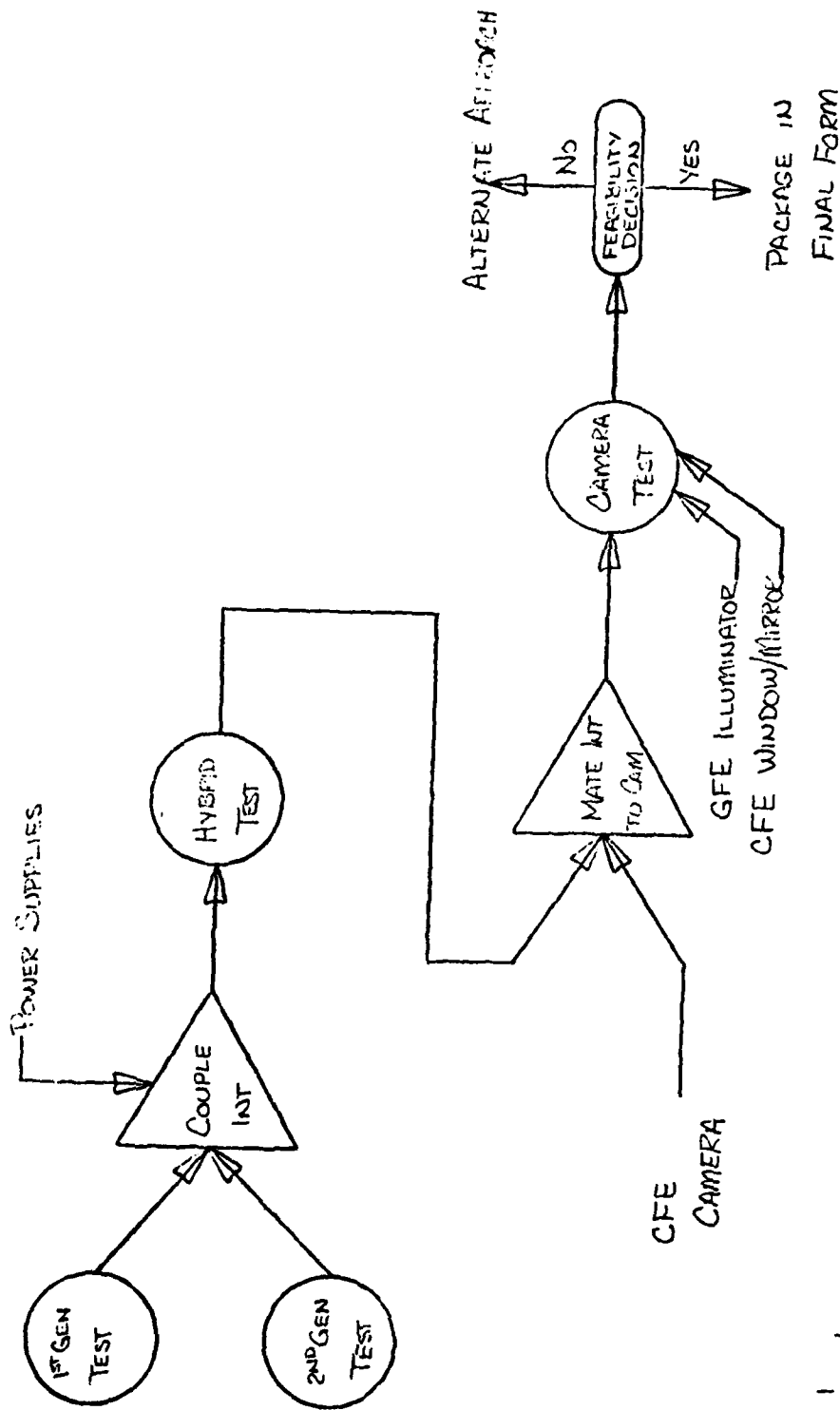

NOTE : ALL TESTING INCLUDE BOTH
PASSIVE AND GATED TESTS

FIGURE 1: DOUBLE GATING FEASIBILITY FLOW PLAN

The first stage intensifier is a proximity focus, second generation, image intensifier (wafer). This first stage is fiber optically coupled to a second stage intensifier which is an electrostatic focus, gateable, first generation type. Both stages are gated simultaneously to maximize rejection capability. The intensifier is shown in Figure 2.

This hybrid configuration intensifier was selected because of several advantages it offers. The most significant advantage is the theoretically high rejection capability of the hybrid. Related to the power supply needed to gate the hybrid, the "float" level on the first stage intensifier is low ($\sim 10\text{Kv}$) compared to other multiple stage intensifiers ($\sim 24\text{Kv}$). This low float voltage simplifies the insulation problems normally associated with gating power supplies. Also, the "swing" voltage (focus to cut-off voltage) on the first stage is low ($\sim 250\text{v}$) compared to other multiple stage intensifier, first stages (~ 2100 volts). These advantages in addition to its electro-optical performance resulted in the selection of the hybrid intensifier as the candidate double gated intensifier.

THEORY

The basic theory behind double gating is to simultaneously turn off (cut-off) both intensifiers; consequently, any light which leaks thru the first stage will be rejected by the second stage. The "light leaks" can be from

1. light at the illuminator wavelength which leaks thru the first stage intensifier,
2. incomplete turn-off of the first stage intensifier, and
3. incomplete turn-off of the second stage intensifier.

Light at the illuminator wavelength can leak thru the first stage intensifier because the intensifiers are not truly opaque. The effects of this leakage can be minimized by specifying a very low sensitivity of the second stage photocathode

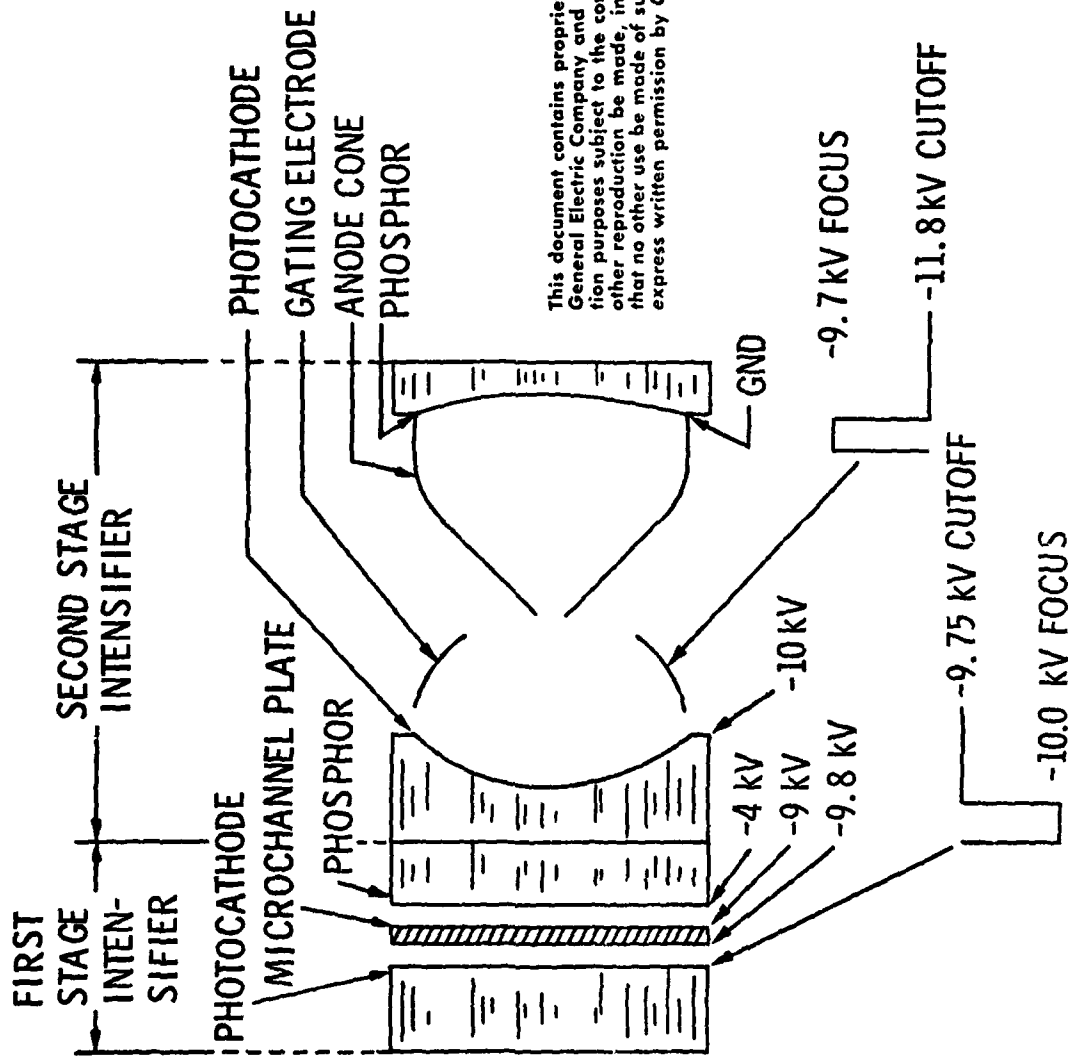

This document contains proprietary information of the General Electric Company and is rendered for evaluation purposes subject to the condition that no copy or other reproduction be made, in whole or in part, and that no other use be made of such information without express written permission by General Electric.

Figure 2. Intensifier

at the illuminator wavelength. The second stage phosphor screen luminance, $L_{ph(2)}$, as a result of this leakage is given by the following equation.

$$L_{ph(2)} = H_{\lambda(1LL)} \cdot S_{\lambda(2)} \cdot V(2) \cdot \epsilon(2) \cdot t_{\lambda(1)} \quad (1)$$

where $H_{\lambda(1LL)}$ is the illuminator irradiance,

$t_{\lambda(1)}$ is the transmission of the first stage intensifier,

$S_{\lambda(2)}$ is the spectral response of the second stage intensifier photocathode at the illuminator wavelength,

$V(2)$ is the applied voltage on the second stage intensifier, and

$\epsilon(2)$ is the phosphor screen efficiency.

Incomplete gating of the first stage intensifier results in excitation of the first stage phosphor screen which is our case is a P-20 (green). The excitation of the first stage phosphor screen has two effects. First, the phosphor screen luminance could pass thru the second stage and be attenuated only by the second stage transmission. Second, the phosphor screen luminance can excite the second stage photocathode which in turn results in a second stage phosphor screen luminance. The phosphor screen luminance due to the second effect is attenuated by the gating efficiency of the second stage intensifier. The first effect results in a phosphor screen luminance, $L_{ph(2)}$, given by the following equation

$$L_{ph(2)} = L_{ph(1)} \cdot t(2) \quad (2)$$

where $t(2)$ is the transmission of the second stage intensifier, and

$L_{ph(1)}$ is the phosphor screen luminance of the first stage intensifier.

The phosphor screen luminance of the first stage, $L_{ph(1)}$, is given by the following equation

$$L_{ph(1)} = H_{\lambda(1LL)} \cdot S_{\lambda(1)} \cdot g_i \cdot V(1) \cdot \epsilon(1) \cdot R(1) \quad (2a)$$

where $H_{\lambda(1LL)}$ is the illuminator irradiance

$S_{\lambda(1)}$ is the spectral response of the first stage intensifier photocathode at the illuminator wavelength.

g_i is the microchannel plate current gain,

V(1) is the applied mcp/phosphor voltage,

E(1) is the phosphor screen efficiency, and

R(1) is the gating efficiency.

The second effect results in a phosphor screen luminance, $L_{ph(2)}$, given by the following equation

$$L_{ph(2)} = L_{ph(1)} \cdot S_{P-20} \cdot V(2) \cdot E(2) \cdot R(2) \quad (3)$$

where $L_{ph(1)}$ is given by equation (2a)

S_{P-20} (2) is the spectral response of the second stage intensifier photocathode to a P-20 phosphor,

V(2) is the applied voltage on the second stage intensifier,

E(2) is the phosphor screen efficiency of the second stage intensifier, and

R(2) is the gating efficiency of the second stage intensifier.

All of these events occur independently, consequently, the phosphor screen luminance, $L_{ph(2)}$, is given by the following equation

$$L_{ph(2)} = L_{ph(1)} + L_{ph(2)} + L_{ph(2)} \quad (4)$$

Several assumptions have previously been made regarding the rejection capability of the double gated hybrid, image intensifier. These assumptions are

1. the first stage phosphor screen luminance $L_{ph(1)}$ is zero because of the gating technique (photocathode switching), and
2. the second stage phosphor screen luminance, $L_{ph(2)}$ is worst case i.e. along the bias cut for the first stage, and thru the anode cone in the second stage.

These assumptions, as well as the overall theory are to be confirmed by this test plan.

The theory has described how the intensifier rejects unwanted, backscattered energy. It is now important to translate this intensifier capability into a system performance parameter. Using the phosphor screen luminance, $L_{ph(2)}$, of equation (4), a modulation factor due to gating, M_G , can be determined. The modulation factor, M_G , is given by the following equation

$$M_G = \frac{L_{ph(2)}_{on} - L_{ph(2)}}{L_{ph(2)}_{on} + L_{ph(2)}} \quad (5)$$

where $L_{ph(2)_{on}}$ is the average phosphor screen luminance during an "on" time. This modulation factor multiplies the intensifier modulation factor at all spatial frequencies. At the system level, all spatial frequencies will be degraded by this modulation factor.

MEASUREMENTS

The measurements to be performed as part of this feasibility analysis are broken down into three phases. The first phase measurements are performed on each stage of the hybrid image intensifier. The second phase measurements are performed on the coupled intensifier assembly. All of these procedures are basically the same. Figure 3 summarized these standard measurement in terms of calibration and measurement parameters, governing equations, and alternate forms of the governing equations. These alternate equations are used to evaluate the theory or as a cross check on measured results. The third phase measurements are performed on the complete intensified camera system. Figure 4 summarizes the format in which the results of the testing to be performed, will be tabulated.

The intensifier rejection measurement and the active mode system measurements are not standard techniques. The following paragraphs describes these measurement procedures.

Standard on/off ratio rejection measurement techniques are not applicable to high rejection capability image intensifiers because

1. there is a risk of damage to the intensifier photocathode;
2. there is a strong possibility that the rejection ratio is greater than the linear operating range of the device; and
3. the standard procedure calls for the intensifier to be operated in a d.c. mode not at its final PRF.

The procedure to be outlined eliminates all of the drawbacks of the standard on/off ratio measurement. A high power light emitting diode (LED) is used as the measurement source. (See Figure 5) The LED spectral irradiance, H_{λ} (LED) is calibrated.

MEASUREMENT	CALIBRATION PARAMETER	MEASUREMENT PARAMETER	GOVERNING EQUATION	ALTERNATE FORMS OF EQUATION
LUMINOUS GAIN, G_L	E_{PC}	Lph	$G_L = Lph/Epc$	$G_L = S_L \cdot V \cdot \epsilon$ $G_L = S_L \cdot gi \cdot V \cdot \epsilon$
EQUIVALENT BACKGROUND ILLUMINANCE, EBI	G_L	Lph	$EBI = Lph/G_L$	
PHOTOCATHODE RESPONSE, S, S_L	A_{PC}, H, E_{PC}	ipc, λ ipc, L	$S_\lambda = ipc, \lambda / H \lambda A_{PC}$ $S_L = ipc, L / Ebc A_{PC}$	$S_L = \int S_\lambda H_\lambda d\lambda / 680 \int K_\lambda H_\lambda d\lambda$
GREEN GAIN, G_G	$Epc (P-20)$	Lph	$G_G = Lph/Epc (P-20)$	$G_G = S_L (P-20) \cdot V \cdot \epsilon$
ON/OFF RATIO, R	Epc	Lph (on) Lph (off)	$R = Lph (on) / Lph (off)$	$Lph(On) = Epc \cdot G_L$

Figure 3. Image Intensifier Measurement/Computation Table

TESTS TO BE PERFORMED	RESULTS		UNITS
	COMPUTED	MEASURED	
SECOND GENERATION INTENSIFIER a. LUMINOUS GAIN, G_L (1) b. PHOTOCATHODE SPECTRAL RESPONSE c. EBI, Lph d. STATIC - OFF, Lph e. DYNAMIC - OFF, Lph f. ON/OFF RATIO g. TRANSMISSION		SEE CURVE	FT.L./FT.C. MA/W FT.L. FT.L. FT.L. ----- -----
FIRST GENERATION INTENSIFIER a. Green Gain, G_L (1) b. Photocathode Spectral Response c. EBI, Lph d. Static - Off, Lph e. Dynamic - Off, Lph f. On/Off Ratio g. Transmission		SEE CURVE	FTL/FTC MA/W FTL FTL FTL ----- -----
HYBRID ASSEMBLY a. Luminous Gain, G_L (1 + 2) b. EBI, Lph c. Static - Off, Lph d. Dynamic - Off, Lph e. On/Off Ratio			FTL/FTC FTL FTL FTL -----
CAMERA SYSTEM a. Passive Black/White Sig. b. Active Black/White Sig. 1. 1st Stage only 2. Both Stages C. Resolution/Sensitivity 1. Passive 2. 1st Stage Gated 3. Both Stages Gated		SEE CURVE SEE CURVE SEE CURVE	V V V TVL/PH TVL/PH TVL/PH

Figure 4. Double Gating Feasibility Evaluation Data Sheet

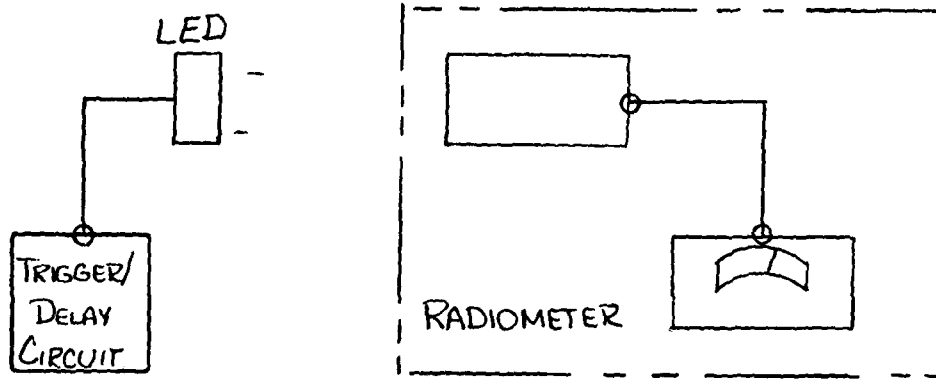

CALIBRATION SET-UP

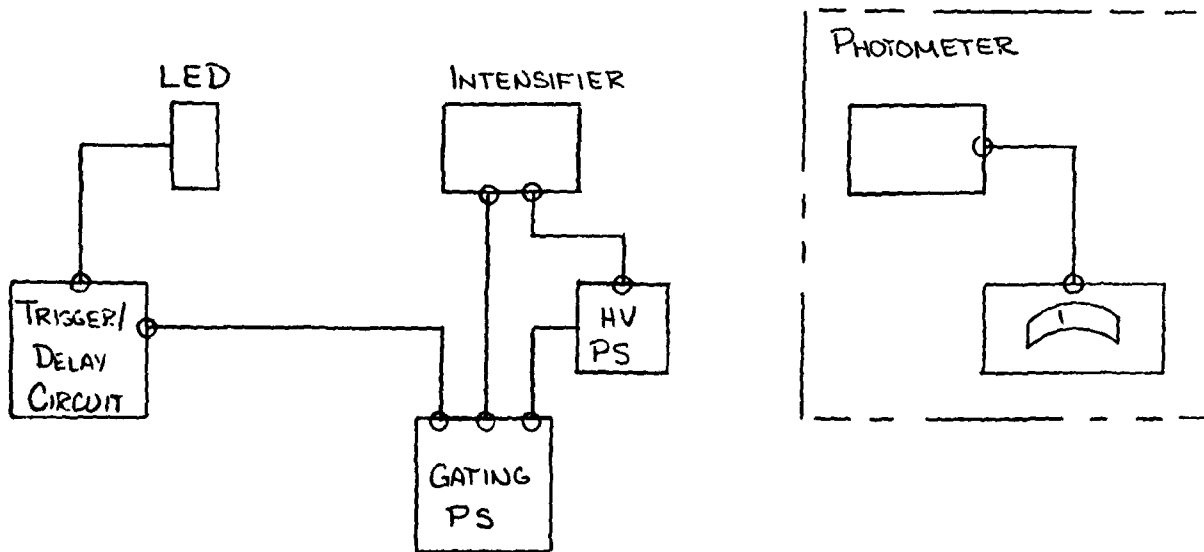

MEASUREMENT SET-UP

FIGURE 5: INTENSIFIER REJECTION CAPABILITY TEST SET-UP

The LED is pulsed "on" during the intensifier "off" time. (Refer to figure 6.) During this time, the phosphor screen luminance is measured with a photometer. (This phosphor screen luminance is $L_{ph(2)}$ of equation (4).) To compute the on/off ratio, the following equation is used

$$R = L_{ph(2)_{on}}/L_{ph(2)} \quad (6)$$

where $L_{ph(2)_{on}}$ is given by

$$L_{ph(2)_{on}} = H_{\lambda}(LED) \cdot G_L(1+2) \cdot S_{\lambda}(LED)/S_L(1) \quad (7)$$

where $G_L(1+2)$ is the luminous gain of the hybrid intensifier, $S_{\lambda}(LED)$ is the first photocathode response to the LED, and S_L is the first photocathode luminous sensitivity.

All terms in equation (7) with the exception of $L_{ph(2)_{on}}$ are measured. As a result of the intensifier on/off ratio testing, two values are obtained. The first is the average phosphor screen luminance when a high power source (LED) is turned-on during an intensifier "off" time. (This mode of operation is analogous to actual system operation.) Second, a computed on/off ratio is obtained.

The active mode system measurements are to be used to relate intensifier rejection capability to system performance. Three tests are to be performed to evaluate the active system performance:

1. low spatial frequency amplitude response,
2. resolution sensitivity at 25% contrast, and
3. real world simulation.

As a result of the intensifier measurements, a phosphor screen luminance term $L_{ph(2)}$ is obtained. With this quantity and knowing the average phosphor screen luminance, $\overline{L_{ph(2)_{on}}}$, a modulation as a function $\overline{L_{ph(2)_{on}}}$ can be determined. This modulation, M_G , is given by the following equation

$$M_G = \frac{\overline{L_{ph(2)_{on}}} - L_{ph(2)}}{\overline{L_{ph(2)_{on}}} + L_{ph(2)}} \quad (8)$$

INTENSIFIER PULSE

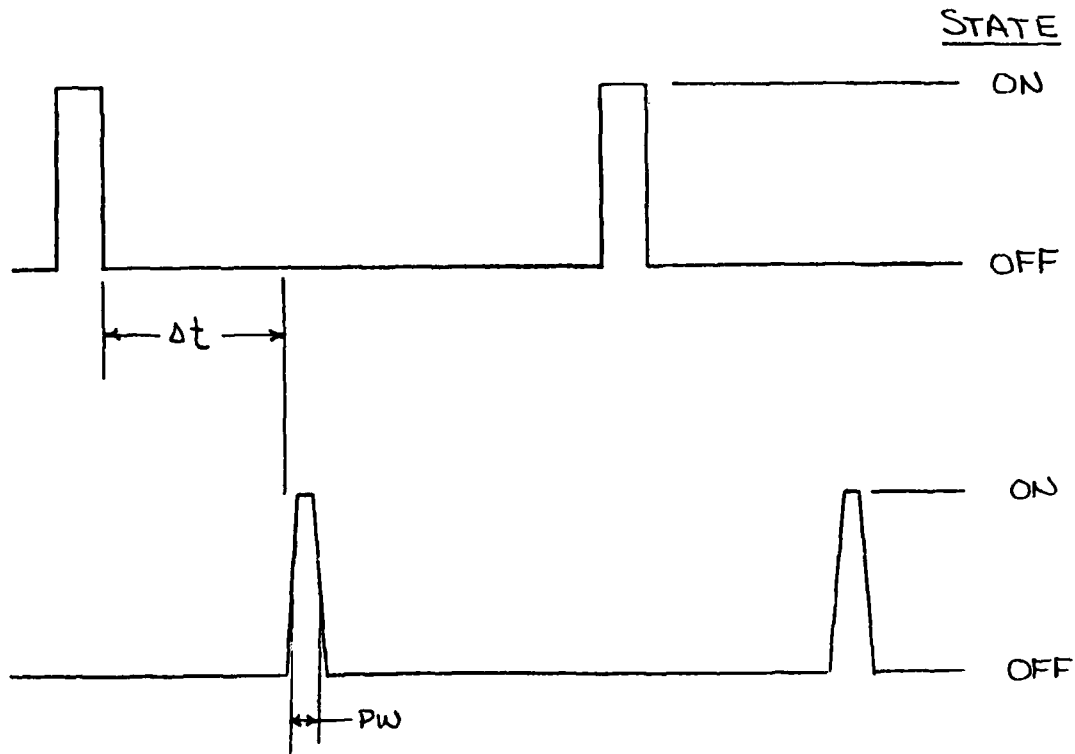

LED PULSE

Δt : DELAY (ADJUSTABLE)
PW : PULSE WIDTH (ADJUSTABLE)

FIGURE 6 : TIMING DIAGRAM

where $\overline{l_{ph(2)on}}$ is given by the following equation

$$L_{ph(2)on} = E_{pc} \cdot G_L (1 + 2) \cdot B \quad (9)$$

where E_{pc} is the photocathode illuminance,

$G_L(1 + 2)$ is the luminous gain of the hybrid, and

B is the intensifier duty factor.

All terms in equation (9) are measured. The active mode system measurement consists of imaging a low spatial frequency target on the intensifier photocathode.

The intensifier is operated first in the passive mode and all special video processing is switched out. The passive modulation, M_A , is measured. The intensifier is placed in the gated mode with the illuminator pulsed "on" during an intensifier "off" time and the modulation, M_A , again measured. (Refer to Figure 7.) The modulation due to gating, M_G , is given by

$$M_G = M_A / M_p \quad (10)$$

This value can then be compared to the M_G value obtained in equation (8). The second measurement-resolution sensitivity at 25% contrast - attempts to quantify the impact of the modulation due to gating, M_G . (See Figure 7.) The low contrast resolution sensitivity, particularly at low illumination levels would be most severely degraded by addition modulation. To completely evaluate the 25% contrast resolution sensitivity, five tests are performed:

1. Resolution sensitivity with the intensifier passive and no LED operating;
2. Resolution sensitivity with both intensifiers gated and no LED operating;
3. Resolution sensitivity with both intensifiers gated and no LED operating;
4. Resolution sensitivity with one intensifier gated and no LED operating; and
5. Resolution sensitivity with one intensifier gated and the LED operating

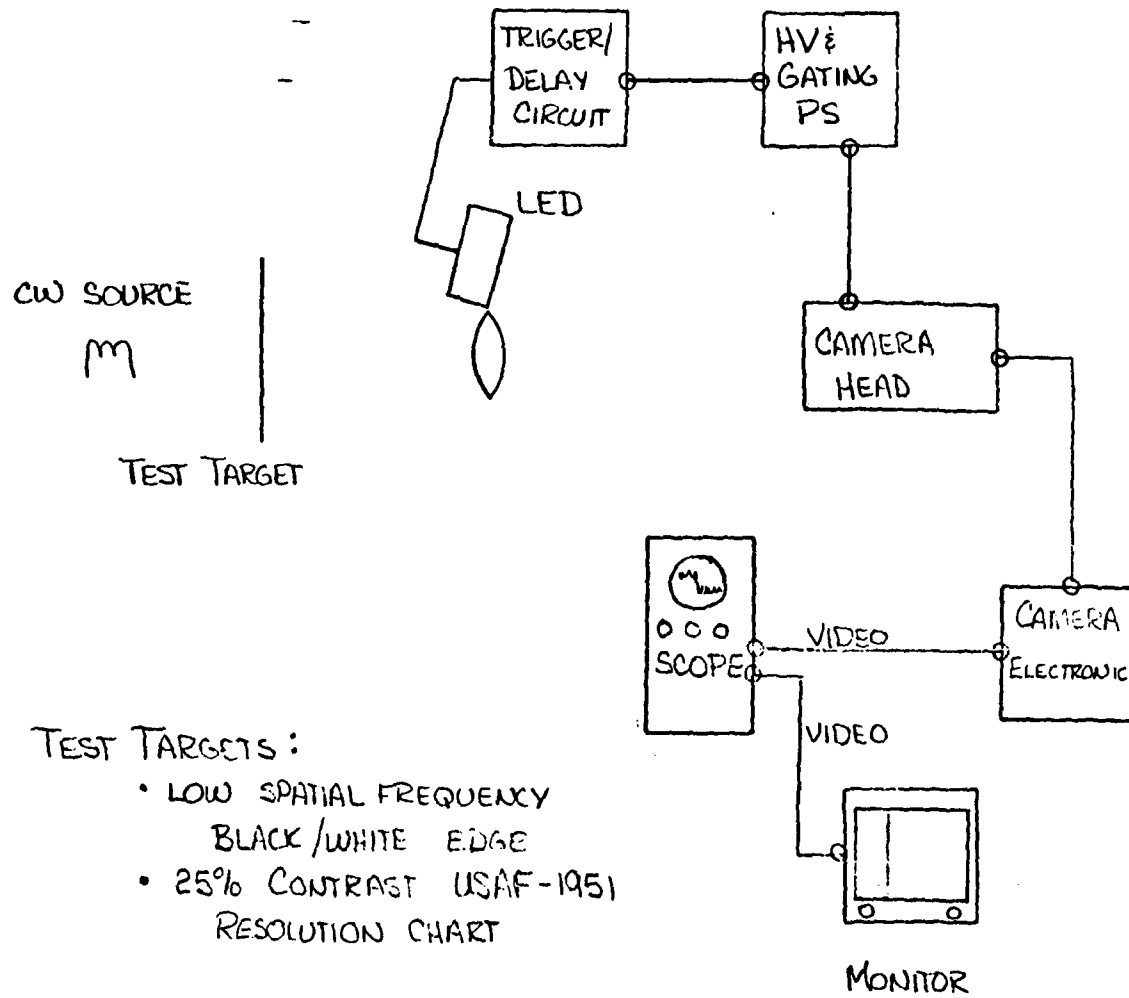

FIGURE 7: ACTIVE MODE SYSTEM MEASUREMENT SET-UP

These active system tests have attempted to evaluate the concept of modulation due to gating, and measure the impact of incomplete rejection of the unwanted energy on system performance.

The final active system test is a real world simulation test. (See Figure 8.) The real world simulation uses a GFE illuminator and an uncoated window. The configuration is such that the illuminator pulse will pass thru the uncoated window, however, since the window is not coated, a percentage ($\sim 4-8\%$) of the illuminator energy will be reflected into the camera. This configuration matches the real system. The camera itself will be gated and will have an RG-780 filter. The camera so equipped will allow testing of the camera at various hours of the day and twilight because the ambient illumination will be attenuated by both the filter and the gating. The real world scene will be video taped with an without the illuminator operating. If the video does not degrade with the illuminator operating, then the double gating concept would be suitable for a common aperture television. The results of the real world simulation should be predicted from the results of the previous testing.

RESULTS

The data compiled as part of this test plan must be reduced to answer three technical questions.

1. Are the assumptions related to intensifier performance valid?
2. Is the theory concerning the intensifier operation correlate with measured data?
3. Can the system performance be predicted as a function of the intensifier rejection capability?

FEASIBILITY ASSESSMENT

The feasibility of the double gated, hybrid, image intensifier to reject unwanted, scattered energy is based on the active system test results. If a resolution degradation is found during the testing, then the source of the degradation cannot be corrected, then the magnitude of the degradation will be evaluated in terms

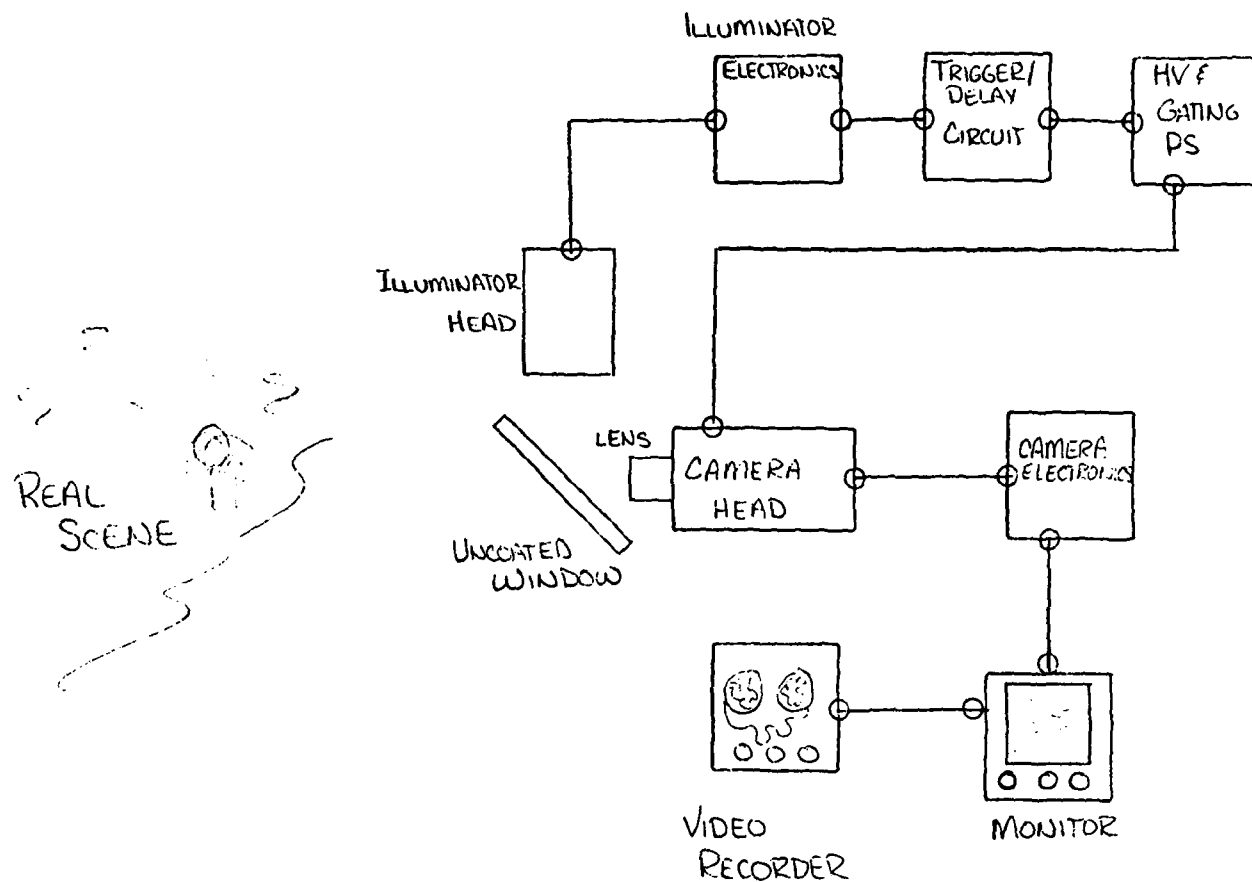

FIGURE 8: REAL WORLD SIMULATION ACTIVE MODE TEST SET-UP

of real world performance. Ultimately, the double gated, hybrid, image intensifier will either perform as anticipated or an alternate method of rejection of unwanted scattered energy must be used.

**COMMON APERTURE TECHNIQUES
FOR
IMAGING ELECTRO-OPTICAL SENSOR (CATIES)
R&D STATUS REPORT NO. 3**

I. GENERAL

This third research and development status report describes the activities of GE/AESD in the development of the Common Aperture Techniques for Imaging Electro-Optical Sensors (CATIES) Program under Contract F33615-76-C-1135, Item No. 0002, CDRL Sequence No. 2.

II. GATING STUDY

The image intensifiers specified and ordered to be used in the double gated hybrid intensifier module have not been received. The first generation intensifier from RCA and the second generation device from ITT are due to be shipped 1 October and 12 November 1976, respectively. During this reporting period, all miscellaneous material (including calibrated neutral density filters and high power light-emitting diodes) to be used in evaluation tests were received. Installation of these components in the intensifier test facility is complete and calibration has started.

Calibration of the equipment prior to initiation of intensifier tests represents a substantial effort involving radiometric and photometric measurements. A general outline of the calibration being performed is shown in Table 1.

TABLE 1. GENERAL CALIBRATION OUTLINE

Function	Method	Equipment Used
Calibrate spectroradiometer	Observe traceable NBS source	<ul style="list-style-type: none"> ● EGG Spectroradiometer ● NBS Source
Determine spectral irradiance from light source in test setup	Compare test source with NBS Secondary Standard of Spectral Irradiance	<ul style="list-style-type: none"> ● NBS Traceable - Secondary Source of Irradiance ● EGG Spectroradiometer
Calibrate test set filters	Use test source calibrated above and observed spectral irradiance through filters	Calibrated Radiometer
Calibrate pulsed source	Measure total power emitted from pulse source	Broadband Radiometer
Perform radiometric/photometric conversions for interpretation of photometric measurements and comparison with other previous data	Use spectral conversion computer program	Honeywell Series 6000 Computer

This calibration procedure will continue during the following reporting period, and is scheduled for completion 15 October 1976. At that time testing of the first generation image intensifier will begin.

III. SYSTEM CONFIGURATION

a. Active Television Illuminator

The Grumman High Radiance Illuminator has been received at GE/AESD. Attempts are continuing to get illuminator lens design prescription

data from Grumman. This data is required for preliminary design and will be needed for detailed optical design during phase 2 of the program.

b. Forward Looking Infrared (FLIR) Detecting Set

Although selection of the FLIR System for CATIES has not been made, preliminary system design, and the optics subsystem specification and work statement are being prepared on the assumption that the Honeywell AN/AAQ-9 Serial Scan FLIR will be utilized. Complete design drawings of the optical system for this FLIR have been received from Honeywell. This information will be used in designing the supplementary FLIR optics, which will be part of the CATIES System. The GE/AESD goal is to include the existing FLIR optical system (and Gallium Arsenide (Ga As) illuminator integral array optics) in the computer design program for the CATIES optical subsystem. This will allow GE/AESD to optimize the system as a whole, and will provide maximum flexibility for future system modifications. The Honeywell optics design data, although physically on hand, will not be available for use in Engineering until a proprietary information exchange agreement is negotiated between GE/AESD and the Honeywell Radiation Laboratories. Negotiations on this agreement are underway and should be completed in a few weeks.

IV. OPTICS SUBSYSTEM

A preliminary baseline optical subsystem has been designed, and is being reviewed. This baseline system which is similar to the all dedicated approach originally proposed will be used as a basis for the optical subsystem specification. Although the final optical design may vary considerably from the present baseline system, its performance will be at least as good as the baseline, and hopefully better. The baseline approach will be supplied to all bidders on the optical subsystem computer design to be used as a starting point for design consideration. Work on the optical subsystem specification and work statement is continuing and is scheduled for completion 14 November 1976.

V. IR BAND SHIFT CONSIDERATIONS

At the request of the Avionics Laboratory project office, GE/AESD investigated the possibility of an optical system design configuration utilizing an objective lens common to a 3 to 5 micron band FLIR and an 0.85 micron active television system. As discussed in the GE/AESD original contract proposal, this approach reduces the duplication of field switching apparatus, and reduces the overall size of the spectral separator, and all following IR and TV optical components. This should also result in a reduction of recurring costs in production systems. An investigation was conducted to determine if such a common objective lens could be designed to provide sufficient chromatic correction from 0.65 to 5 microns.

A preliminary computer analysis was performed on a catadioptric objective lens with a margin mirror in which the lens and rear surface mirror substrates were calcium fluoride. This material was found to be better than other candidate materials such as zinc selenide or sapphire in obtaining adequate chromatic correction. The primary limitation with calcium fluoride was its thermal shock property; however it is felt that this problem could be controlled in a system design. In general, GE/AESD believes that an excellent design could be built with optical performance approaching that of the all dedicated system, and with a more attractive physical/mechanical configuration. The nonrecurring cost differential between this common objective system and the all dedicated system was not accurately determined, but it is felt that the cost of the common objective optical system would be close to that of the potassium bromide system proposed originally. The higher nonrecurring cost of the common objective approach is primarily due to the nature of the materials and coating processes involved.

COMMON APERTURE TECHNIQUES
FOR
IMAGING ELECTRO-OPTICAL SENSOR (CATIES)
R&D STATUS REPORT NO. 4

I. GENERAL

This fourth R & D Status Report describes the activities of GE/AESD in the development of the Common Aperture Techniques for Imaging Electro-Optical Sensors (CATIES) Program under Contract F33615-76-C-1135, Item No. 0002, CDRL Sequence 2.

II. GATING STUDY

During this reporting period, test facilities have been completely calibrated. This calibration includes the following:

- a. Spectroradiometer to primary standard
- b. Working standard
- c. Spectral irradiance at the plane of the photocathode
- d. LED output
- e. Computer program for spectral conversion factors.

The most significant result of the calibration is the correlation between the measured and calculated photocathode illuminance. (Calculated illuminance was derived from spectral irradiance data.) Table 1 summarizes the photocathode illuminance data including standard deviation of measurements made at each filter position.

Worst case correlation between measured and computed photocathode illuminance occurred at the ND6 position where spectroradiometric signal currents were less than 0.1 nanoamps.

Table 1. Photocathode Illuminance vs Neutral Density Filter

ND FILTER	$\overline{E_{PC}}^*$	$\frac{\sigma}{E_{PC}}^*$
0	1.694×10^0	3.2×10^{-2}
1	1.522×10^{-1}	4.83×10^{-3}
2	1.554×10^{-2}	8.25×10^{-4}
3	2.352×10^{-3}	9.08×10^{-5}
4	2.653×10^{-4}	1.79×10^{-5}
5	2.178×10^{-5}	4.64×10^{-7}
6	2.425×10^{-6}	2.64×10^{-7}

*Mean and standard deviation are for five independent measurements at each filter position.

Also related to the calibration, the computer program for computing spectral conversion factors was set up and debugged. This program has the capability of predicting, from spectral sensitivity data, the luminous sensitivity of the photocathode. This predicted result was then compared to measured data. Correlation between measured and predicted photocathode luminous sensitivity was 7.23%. (This deviation included extrapolation of the spectral sensitivity below 500 nanometers.)

The calibrated test set was then used to measure the first generation gated intensifier. Photocathode sensitivity was the first measurement to be performed. Computed luminous sensitivity was 175uamps/lumen as compared to the vendor's measured value of 175uamps/lumen and AESD's measured data of 189uamps/lumen. (AESD measured data represents an 8% deviation.) Other tests are now in progress and should be completed by fiscal week 46.

During this reporting period, direct light transmission through intensifiers was measured on a 40mm gated first generation intensifier and an 18mm second generation wafer intensifier. The first generation intensifier had a transmission of 5.4×10^{-8} as compared to 1×10^{-5} assumed in the proposal. This transmission appeared to be independent of the source position, i.e. with a spot of light at an off axis position on the photocathode (input). Phosphor luminance (output) was the same as the spot located on axis. The position of the spot on the output moved inversely with off axis position of the spot on the input. Spread of the input spot was about 3 to 1 as measured on the output. The second generation intensifier had a transmission of 1.04×10^{-8} as compared to 1×10^{-5} assumed in the proposal. Transmission again appeared to be independent of source position but moved directly with spot location changes on the input. Spread appeared to be 1 to 1 as measured on the output. Finally, the spot as viewed on the phosphor of the second generation intensifier appeared as a speckle pattern similar to pin holes in a neutral density filter. Discussions with the vendor provided no reason for the speckle pattern.

III. PRELIMINARY SYSTEM DESIGN

A. OPTICS Subsystem

The optical subsystem as proposed originally has been reviewed and modified to some extent. A revised optical schematic is attached. This schematic, though very preliminary, will be used as a baseline design and a starting point for the detailed system design which will begin in February. The portion of the schematic showing the laser transmitters is very tentative, since details of the existing GaAs laser optics are not yet available. It is hoped that the illuminator and laser designator/rangefinder

beams can be introduced into the common optical system without requiring a central obscuration.

The preliminary infrared optics design assumes the use of the Honeywell AN/AAQ-9 FLIR. A proprietary exchange agreement between GE/AESD and Honeywell/HRC is signed and in effect.

The specification for the optical subsystem is about 80 percent complete and is scheduled for completion fiscal week 47.

B. GaAs Laser Illuminator

Inspection of the GFE Grumman High Luminance Illuminator, which has been received from AFAL, reveals there may be a considerable effort involved in making it operational. At AFAL request, contact has been made with Grumman to obtain an estimate of time and materials necessary to get the illuminator working. It is Grumman's belief that the illuminator has not been operated for several years. Most of the engineers and technicians who worked on the development system are dispersed, however Grumman feels there is enough talent remaining to make the necessary repairs and adjustments.

IV. SUMMARY

During the next reporting period, testing on the individual intensifiers to be used in the night camera will be completed and coupled tests will begin. The optical subsystem specification and work statement will be completed for an early December release. It is anticipated that refurbishment of the GaAs Illuminator will begin.

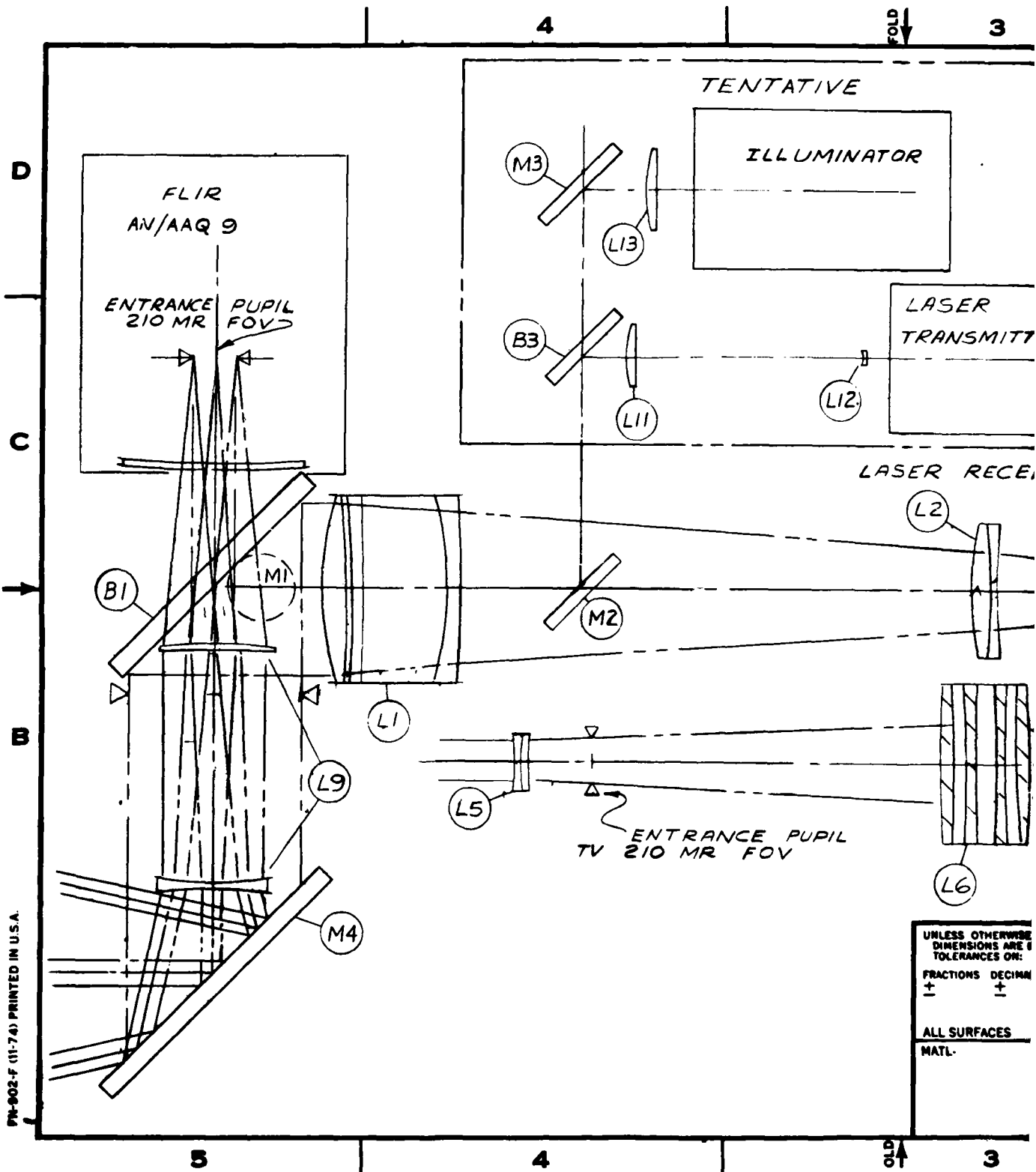

2

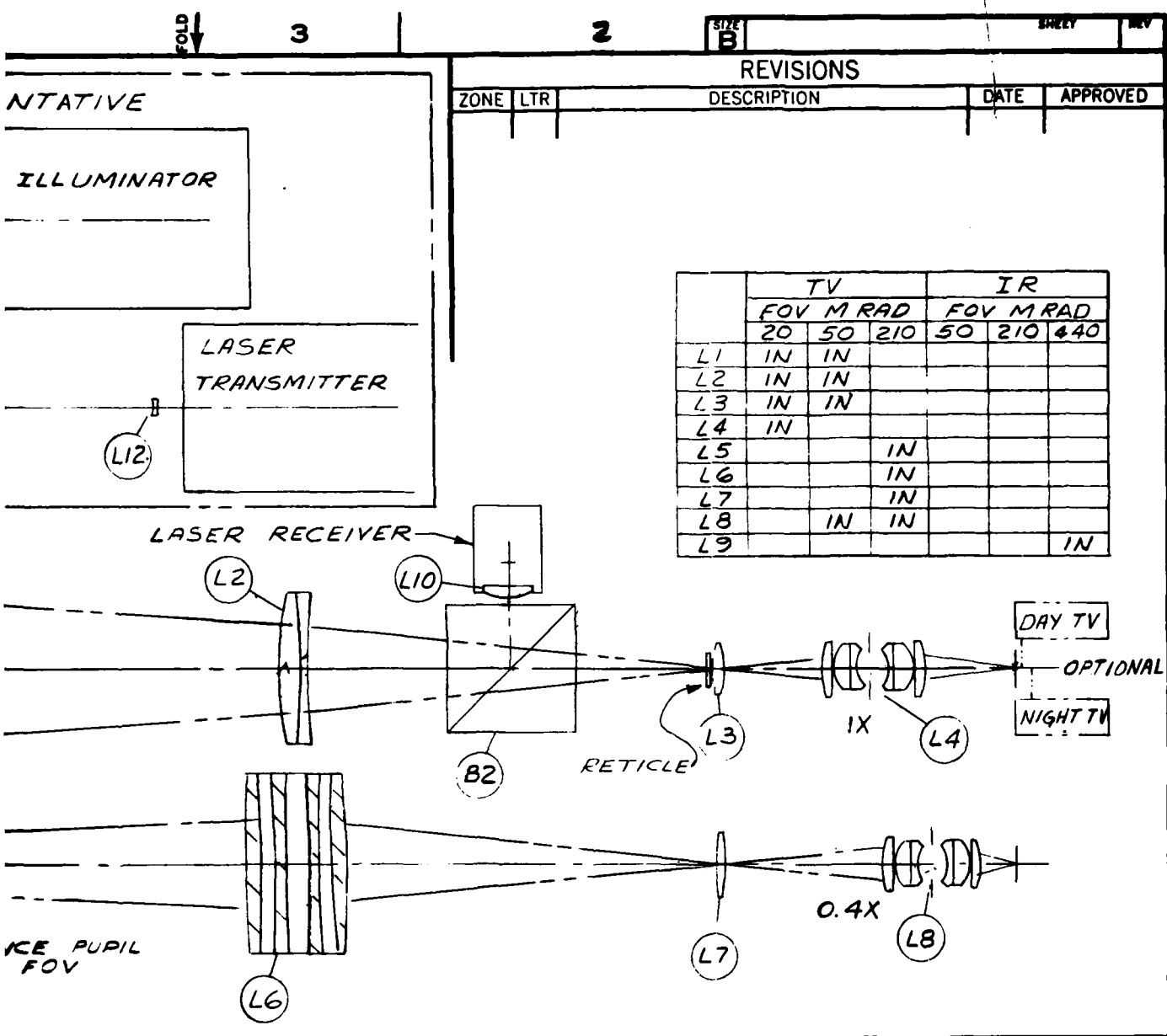

REVISIONS						
ZONE	LTR	DESCRIPTION	DATE	APPROVED	SIZE	REV
					B	

	TV			IR		
	FOV	M	RAD	FOV	M	RAD
	20	50	210	50	210	440
L1	IN	IN				
L2	IN	IN				
L3	IN	IN				
L4	IN					
L5			IN			
L6			IN			
L7			IN			
L8		IN	IN			
L9						IN

UNLESS OTHERWISE SPECIFIED DIMENSIONS ARE IN INCHES. TOLERANCES ON: FRACTIONS DECIMALS ANGLES ± ± ± ALL SURFACES ✓ MATL.	SIGNATURES		DAY	MO	YR	GENERAL ELECTRIC DEPT LOC
	DRAWN <i>[Signature]</i>		28	10	76	
	CHECKED					
	ISSUED					
	ENGRG					CATIES OPTICAL SCHEMATIC
	MFG					
	MATLS					SIZE CODE IDENT NO. B 99971
						SCALE 1/4 SHEET

COMMON APERTURE TECHNIQUES
FOR
IMAGING ELECTRO-OPTICAL SENSOR (CATIES)
R&D STATUS REPORT NO. 5

I. GENERAL

This fifth R & D Status Report describes the activities of GE/AESD in the development of the Common Aperture Techniques for Imaging Electro-Optical Sensors (CATIES) Program under Contract F33615-76-C-1135, Item No. 0002, CDRL Sequence 2.

II. GATING STUDY

During this reporting period, the first generation gated intensifier and an Engineering sample wafer intensifier were tested in the passive and gated modes. Table 1 summarizes the measured performance of both intensifiers in the passive mode.

In the gated tests, the first generation intensifier exhibited a maximum rejection (on-to-off ratio) in the dc off mode of 1.04×10^4 . The rejection appears to be light-level sensitive; that is, the rejection was maximum for photocathode illuminances near 0.06 to 0.6 foot-candles and degraded slightly for illuminances above or below this range of values. The intensifier rejection capability was the same in either the pulsed or dc off modes. Changing the cutoff voltage to a more negative potential did not improve the rejection capability. Table 2 summarizes the rejection performance of the first generation gated intensifier.

The most significant result is the rejection capability of the engineering sample wafer intensifier as shown in Table 3. In the dc off mode, the phosphor screen luminance was independent of photocathode illuminance. That is, with

a photocathode illuminance of 3.3×10^{-5} foot-candles, the phosphor screen luminance (off mode) was 1.39×10^{-5} foot-lamberts; at a photocathode illuminance of 1.42 foot-candles, the phosphor screen luminance was 1.30×10^{-5} foot-lamberts. A sample calculation for on-to-off ratio, R, is shown below.

$$R = L_{ph}(on)/L_{ph}(off)$$

where

$$L_{ph}(on) = E_{pC} \cdot G_L.$$

Substitution of numerical values yields the following

$$R = (1.42 \cdot 7850)/(1.30 \times 10^{-5})$$

therefore $R = 1.86 \times 10^9$.

The gated mode tests could not be performed with a pulsed light emitting diode (LED) equal to 1.42 foot-candles; however, at the equivalent photocathode illuminances obtainable with the LED's, the phosphor screen luminances were the same. This implies that the intensifier rejection capability is the same in either the gated or passive modes. The initial indications from these tests are that all of the rejection needed for a common aperture active television may be achievable by gating the wafer intensifier only.

This result could have important implications in camera and overall CATIES system design. The gating of only the wafer intensifier would mean low voltage gating pulses and the possibility of a camera with self-contained wrap-around gating supply. This would affect overall system packaging, and simplify derotation of the cameras. Due to the significance of this result, a specification has been prepared for a suitable gating power supply. Vendor discussions and meetings have been initiated.

TABLE 1. INTENSIFIER TEST RESULTS

PARAMETER	FIRST GENERATION	SECOND GENERATION
PHOTOCATHODE SENSITIVITY	189 $\mu\text{a}/\ell$ (175 $\mu\text{a}/\ell$)	561 $\mu\text{a}/\ell$ (518 $\mu\text{a}/\ell$)
LUMINOUS GAIN	75.2 @ 10 kV (86 @ 12 kV)	7850 @ 5.1 kV 9900 @ 6.0 kV
P-20 GAIN	22.2 @ 10 kV	Not Applicable

TABLE 2. FIRST GENERATION GATING RESULTS

MODE	\overline{E}_{PC}^* (Foot-Candles)	$L_{ph}(ON)$ (Foot-Lamberts)	$L_{ph}(OFF)$ (Foot-Lamberts)	R (-)
AC	5.42×10^{-3}	4.08×10^{-1}	5.81×10^{-5}	7.02×10^3
DC	1.34×10^{-2}	1.08×10^0	1.16×10^{-4}	9.30×10^3
AC	2.99×10^{-2}	2.25×10^0	2.13×10^{-4}	1.06×10^4
DC	1.31×10^{-1}	9.62×10^1	9.29×10^{-4}	1.04×10^4
DC	1.46×10^0	1.05×10^2	1.28×10^{-2}	8.18×10^3

PASSIVE L_{ph} (EBI) = 6×10^{-6} foot-lamberts

* TO OBTAIN AN EQUIVALENT P-20 ILLUMINANCE WHICH WOULD RESULT IN $L_{ph}(ON)$, MULTIPLY \overline{E}_{PC} BY 3.39

TABLE 3 SECOND GENERATION GATING RESULTS

MODE	\overline{E}_{PC} (Foot-Candles)	$L_{Ph}(ON)$ (Foot-Lamberts)	$L_{Ph}(OFF)$ (Foot Lamberts)	R (-)
AC	3.15×10^{-5}	2.47×10^{-1}	9.3×10^{-6}	2.65×10^4
DC	3.33×10^{-5}	2.61×10^{-1}	6.9×10^{-6}	3.77×10^4
AC	7.87×10^{-5}	6.18×10^{-1}	9.3×10^{-6}	6.65×10^4
DC	2.92×10^{-4}	2.29×10^0	7.5×10^{-6}	3.04×10^5
DC	2.20×10^{-3}	1.73×10^1	8.12×10^{-6}	2.13×10^6
DC	1.47×10^{-2}	1.15×10^2	8.15×10^{-6}	1.41×10^7
DC	1.22×10^{-1}	9.58×10^2	8.2×10^{-6}	1.17×10^8
DC	1.42×10^0	1.11×10^4	6.0×10^{-6}	1.86×10^9

PASSIVE L_{Ph} (EBI) = 2.4×10^{-4} foot-lamberts

III. PRELIMINARY SYSTEM DESIGN

A. Optical Subsystem

The optical subsystem specification draft is complete. Work Statement is partially complete and will be completed during the following reporting period. Specification and Work Statement were scheduled for release in January 1977 but may be delayed until March under a new schedule stretched to match pending funding increments.

B. Laser Illuminator

A quotation of \$8,454 has been received from Grumman Aerospace to refurbish the Gallium Arsenide High Radiance Illuminator. GE/AESD has been informed that Air Force money is available to perform this refurbishment.

Optical system data on the High Radiance Illuminator has been received and is presently being reviewed to determine the degree of compatibility of existing inner anamorphic lens array with CATIES optics. This inner array would be difficult to alter if it is not compatible. The final decision (whether to proceed with this illuminator or with the back-up GLINT illuminator) will probably not be made until the final optics design is underway. The GE/AESD purpose is now to have all the pertinent information on both optical systems available at the start of that detailed design effort. GE/AESD recommends that refurbishment of the High Radiance Illuminator be delayed until the detailed optical design is begun early next year, and if possible that the GLINT illuminator be made available for initial gating/camera tests.

C. PROGRAM STRETCH

GE/AESD has been asked to reschedule the CATIES program from an original 26-month program to a program which is in-phase with planned funding increments in October 1977 and 1978. A schedule has been prepared which accomplishes this stretch to minimize the impact on the detail design phase. The program stretch is accomplished during the fabrication phase - a slower serial fabrication cycle will be followed rather than the quicker parallel effort. The detailed schedule and planned expenditure rates for this new 37-month program are presently being prepared. These will be submitted with the next monthly report.

COMMON APERTURE TECHNIQUES
FOR
IMAGING ELECTRO-OPTICAL SENSOR (CATIES)
R&D STATUS REPORT NO. 6

I. GENERAL

This sixth R & D Status Report describes the activities of GE/AESD in the development of the Common Aperture Techniques for Imaging Electro-Optical Sensors (CATIES) Program under Contract F33615-76-C-1135, Item No. 0002, CDRL Sequence 2.

II. GATING STUDY

During this reporting period, the high resolution second generation intensifier was received and tested. This wafer tube was coupled to the first generation intensifier and the assembly was potted and tested. All testing was performed in accordance with the engineering test procedure. The hybrid image intensifier was mated to the one-inch vidicon tube and preliminary data was taken. The following paragraphs summarize testing performed during this reporting period.

A. Second Generation Test Results

The second generation image intensifier was tested to determine ungated performance as well as pulsed and dc off characteristics. Table 1 summarizes the measured performance in the ungated mode. Refer to Figure 1 and Table 2 for a summary of the pulsed and dc off characteristics. For comparison purposes, Figure 2 also includes the results obtained on the engineering model second generation intensifier. From this data and the gain characteristics of the second generation intensifiers, the

on-to-off ratio can be computed (refer to Figure 2). Data indicates, however, both wafer intensifiers have very high rejection capability. Figure 2 illustrates two problems. First, the pulsed mode on-to-off ratio was lower than the dc off mode ratio. This was traced to stray ambient light (continuous) adding to phosphor luminance during the on time and being integrated by the photometer. (For example, stray light as low as 1.2×10^{-7} foot-candles getting into the wafer intensifier will result in phosphor luminance of 9.1×10^{-6} foot-lamberts.) Compare this value with pulsed phosphor luminance shown in Figure 1. The possibility of stray light getting into the intensifier is higher in the pulsed mode because of test set limitations. The second problem is the increase in phosphor luminance at high photocathode illuminances (~ 1.0 foot-candles) in the high resolution tube. It appears that either the intensifier is "leaking" or the transmission (light thru-put) of this intensifier is lower than observed on the engineering model which measured 1×10^{-8} . More tests presently being performed should explain the increase observed.

TABLE 1. SECOND GENERATION INTENSIFIER UNGATED PERFORMANCE

Parameter	Value	
	GE/AESD	Vendor
Photocathode Sensitivity	312 ua/l	270 us/l
Luminous Gain @ 900V (MCP)	4720	5150
Equivalent Background Input (EBI)	3.31×10^{-11} 1/cm ²	1.45×10^{-11} 1/cm ²
Limiting Resolution	Not measured	>40 lp/mm
Modulation Transfer Function		
2.7 lp/mm	Not measured	0.901
7.5 lp/mm	Not measured	0.701
15.0 lp/mm	Not measured	0.447

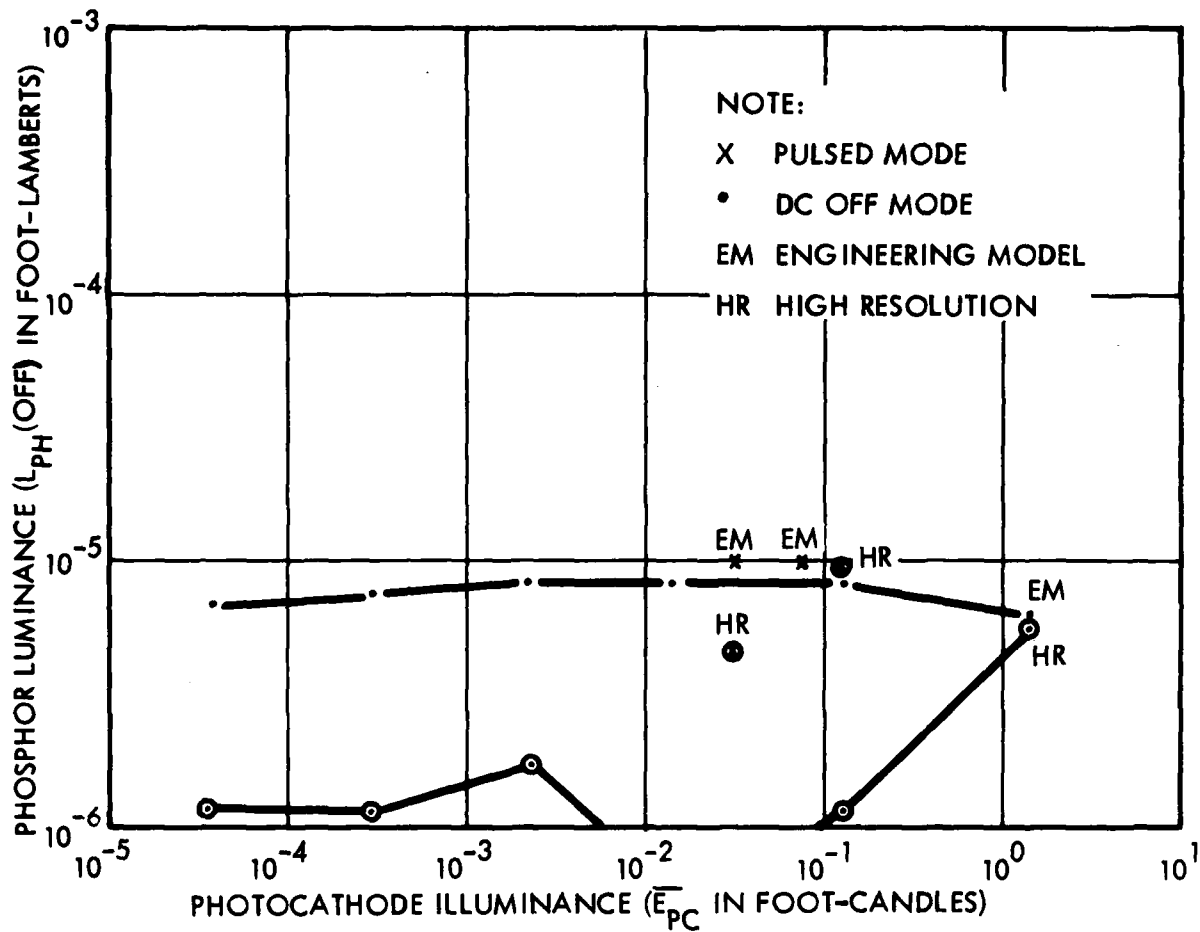

Figure 1. Second Generation Image Intensifier Phosphor Screen Luminance versus Average Photocathode Illuminance for Pulsed and DC Cutoff Operation

TABLE 2. SECOND GENERATION INTENSIFIER GATING RESULTS

MODE	E_{PC} (Foot-Candles)	$L_{PH}(ON)^*$ (Foot-Lamberts)	$L_{PH}(OFF)$ (Foot-Lamberts)	RATIO (-)
AC	3.39×10^{-5}	1.60×10^{-1}	1.16×10^{-6}	1.38×10^5
DC	2.95×10^{-4}	1.39×10^0	1.16×10^{-6}	1.20×10^6
DC	2.21×10^{-3}	1.04×10^1	1.74×10^{-6}	5.98×10^6
DC	1.47×10^{-2}	6.94×10^1	5.8×10^{-7}	1.20×10^8
AC	3.62×10^{-2}	1.71×10^2	4.65×10^{-6}	3.68×10^7
AC	1.20×10^{-1}	5.67×10^2	9.29×10^{-6}	6.10×10^7
DC	1.22×10^{-1}	5.76×10^2	1.16×10^{-6}	4.97×10^8
DC	1.42×10^0	6.70×10^3	5.81×10^{-6}	1.15×10^9

*Calculated

Additional gating tests were performed on the second generation image intensifier to determine the amount of leakage in the intensifier during the off time. To perform this test, the intensifier was operated in the pulsed mode and the light emitting diode (LED) 10S on time was varied throughout the off time of the intensifier. The results are shown in Figure 3. These results are inconclusive because additional measurements revealed the LED's are not off but emit low level energy into the on time of the intensifier. This would account for the increase in phosphor luminance as the delay is increased. This test will be rescheduled when an operational laser illuminator becomes available. The LN₂ cooled GaAs laser diodes with lower threshold current can be driven on and off more quickly than room temperature light-emitting diodes operated below laser threshold current.

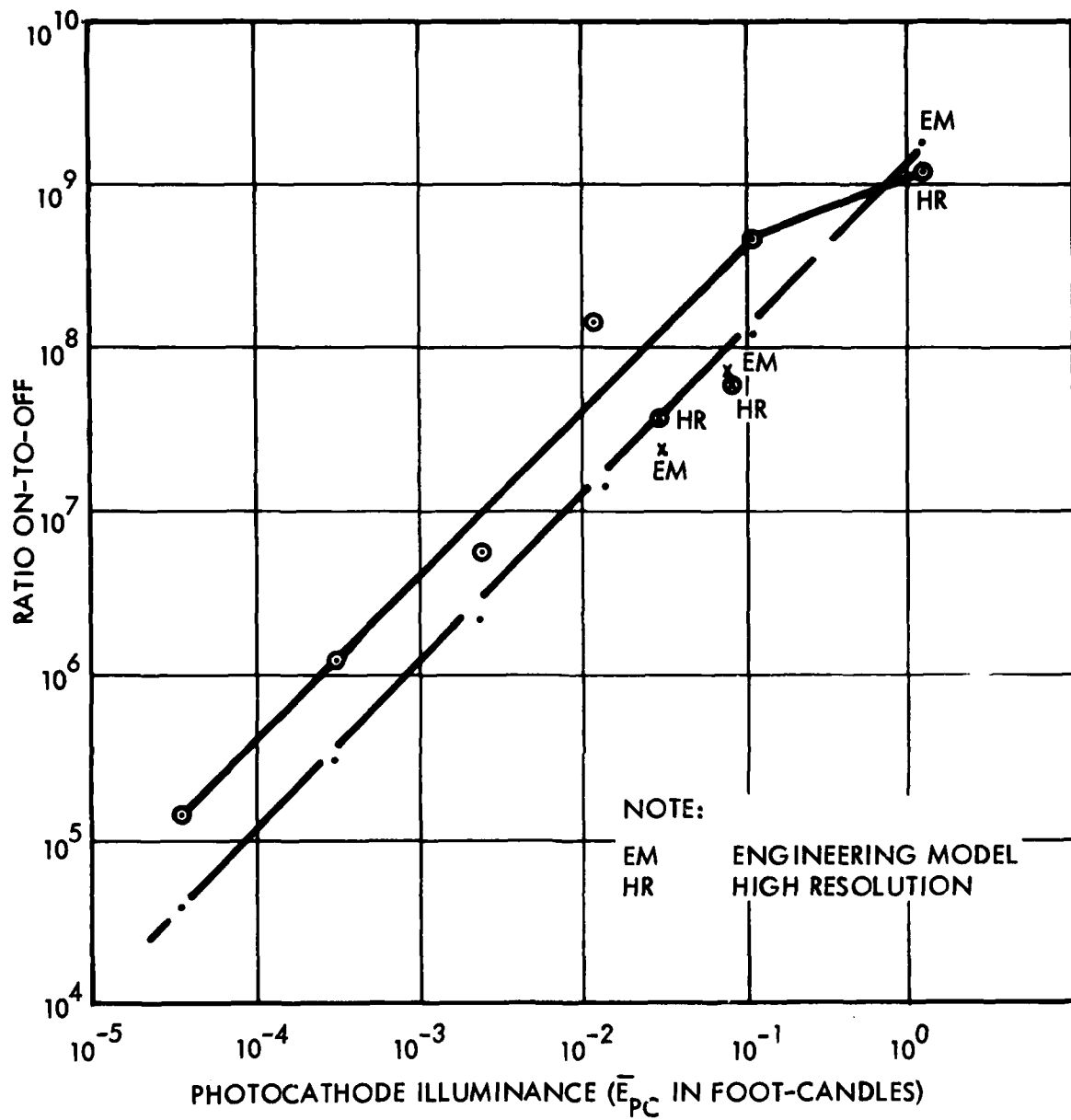

Figure 2. On-to-Off Ratio for Second Generation Image Intensifier

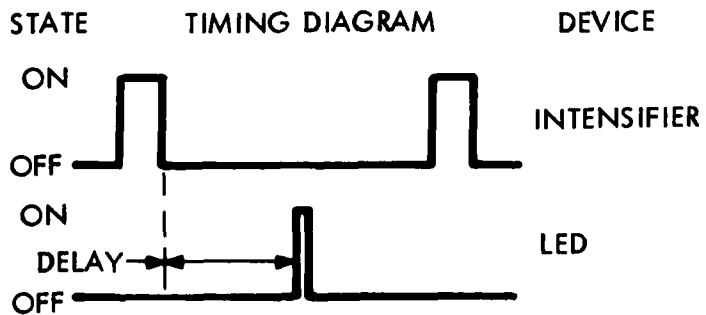
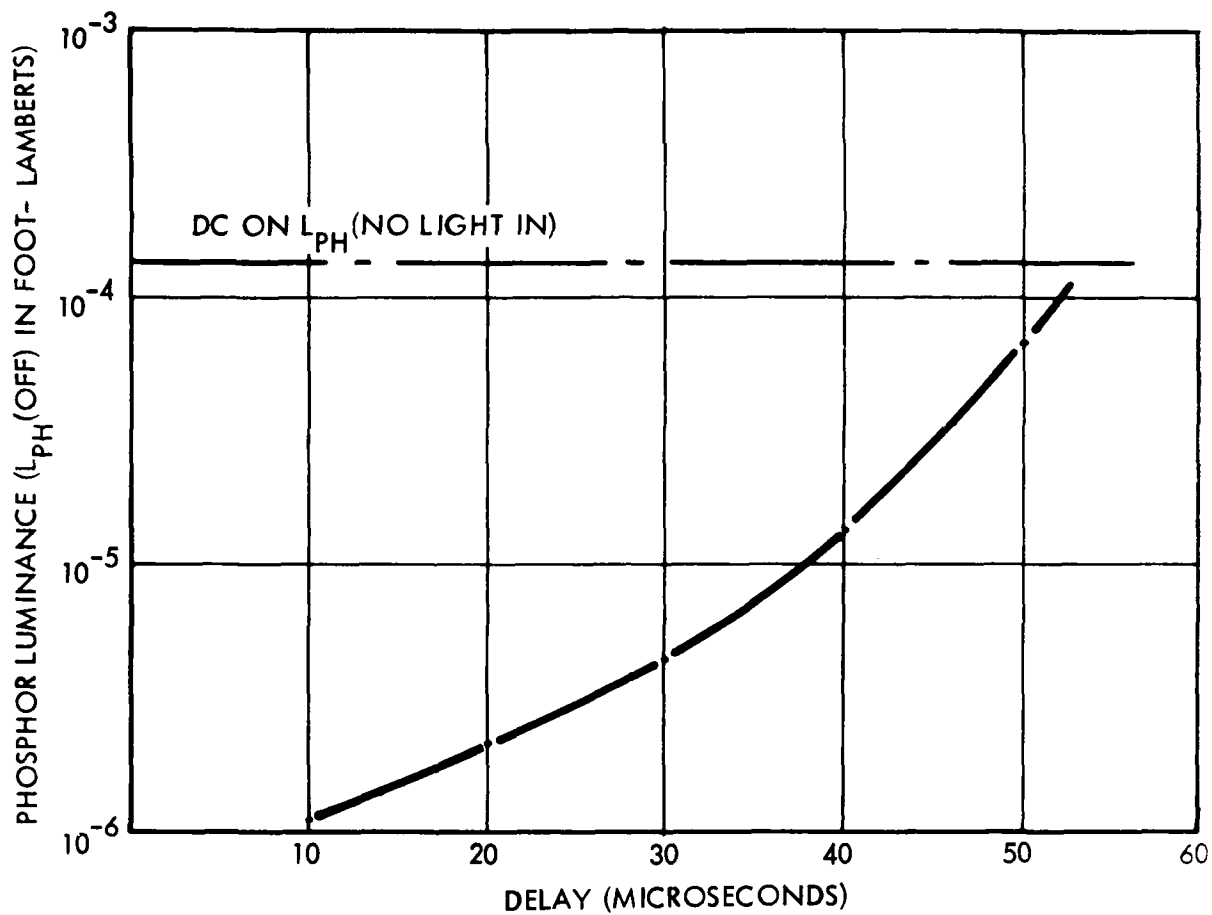

Figure 3. Second Generation Image Intensifier "Leaking" On Test Results

B. Summary of First Generation Intensifier Test Results

The first generation intensifier tests were reported in Monthly R&D Status Report No. 5. In summary, testing showed a maximum on-to-off ratio of 1×10^4 . The intensifier has the same on-to-off characteristics in either the pulsed or dc off mode. Regarding performance characteristics, the intensifier is suitable for use in a double-gated hybrid assembly. The photocathode response at 850 nanometers is higher than requested, which increases the sensitivity of the device to laser light passed through the wafer tube; but this should not present a serious problem.

C. Prediction of Hybrid Performance

Given the high resolution second generation image intensifier performance presented in Table 1 and the first generation image intensifier performance indicated in Table 1 of the fifth Status Report, the hybrid performance can be predicted. The predictions are made in accordance with equations given in the test specification. Table 3 summarizes the expected performance (ungated mode).

TABLE 3. PREDICTED HYBRID INTENSIFIER PERFORMANCE

Parameter	Value
Luminous Gain @ 900V across MCP	87.7K
Equivalent Background Input (EBI)	$3.63 \times 10^{-11} / \text{cm}^2$
Photocathode Response	Same in Second Generation

The on-to-off ratio and off time phosphor luminance characteristics can be predicted and are shown in Figures 4 and 5. These predictions were made for both single and double-gated modes.

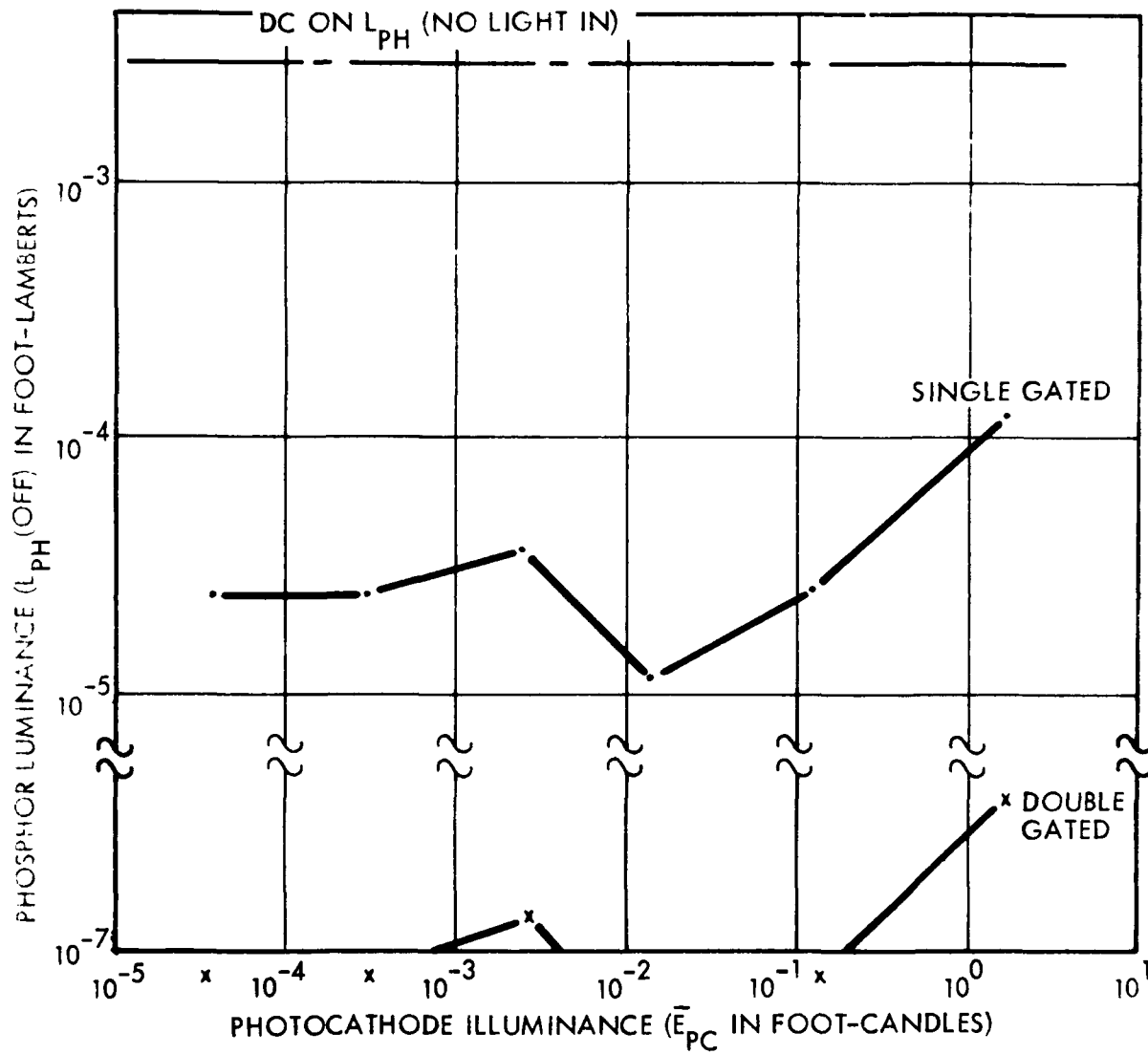

Figure 4. Predicted Hybrid Intensifier Phosphor Screen Luminance versus Average Photocathode Illuminance for DC Off Modes

AD-A087 558

GENERAL ELECTRIC CO UTICA NY AEROSPACE ELECTRONIC SY--ETC F/G 20/6
COMMON APERTURE TECHNIQUES FOR IMAGING ELECTRO-OPTICAL SENSORS --ETC(U)
FEB 80 F33615-76-C-1135

UNCLASSIFIED

79-556C0-10

AFWAL-TR-80-1012

NL

2 of 7
NOA
Q-100

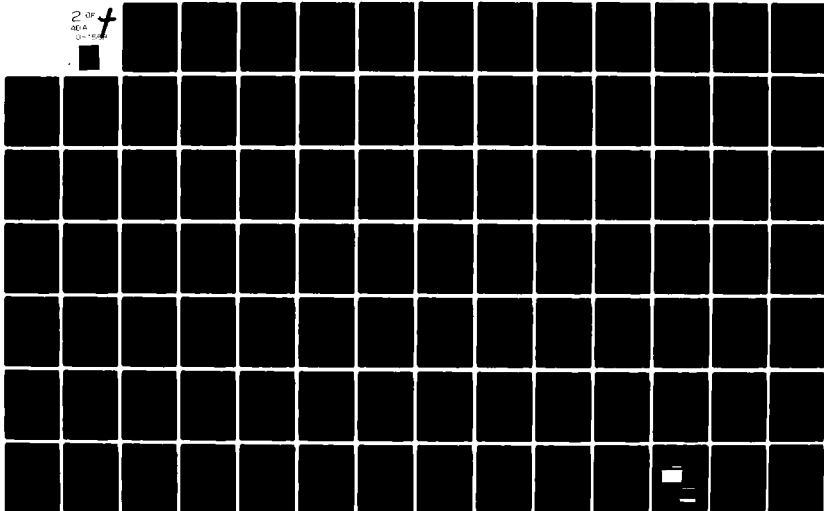

11-80-1-100

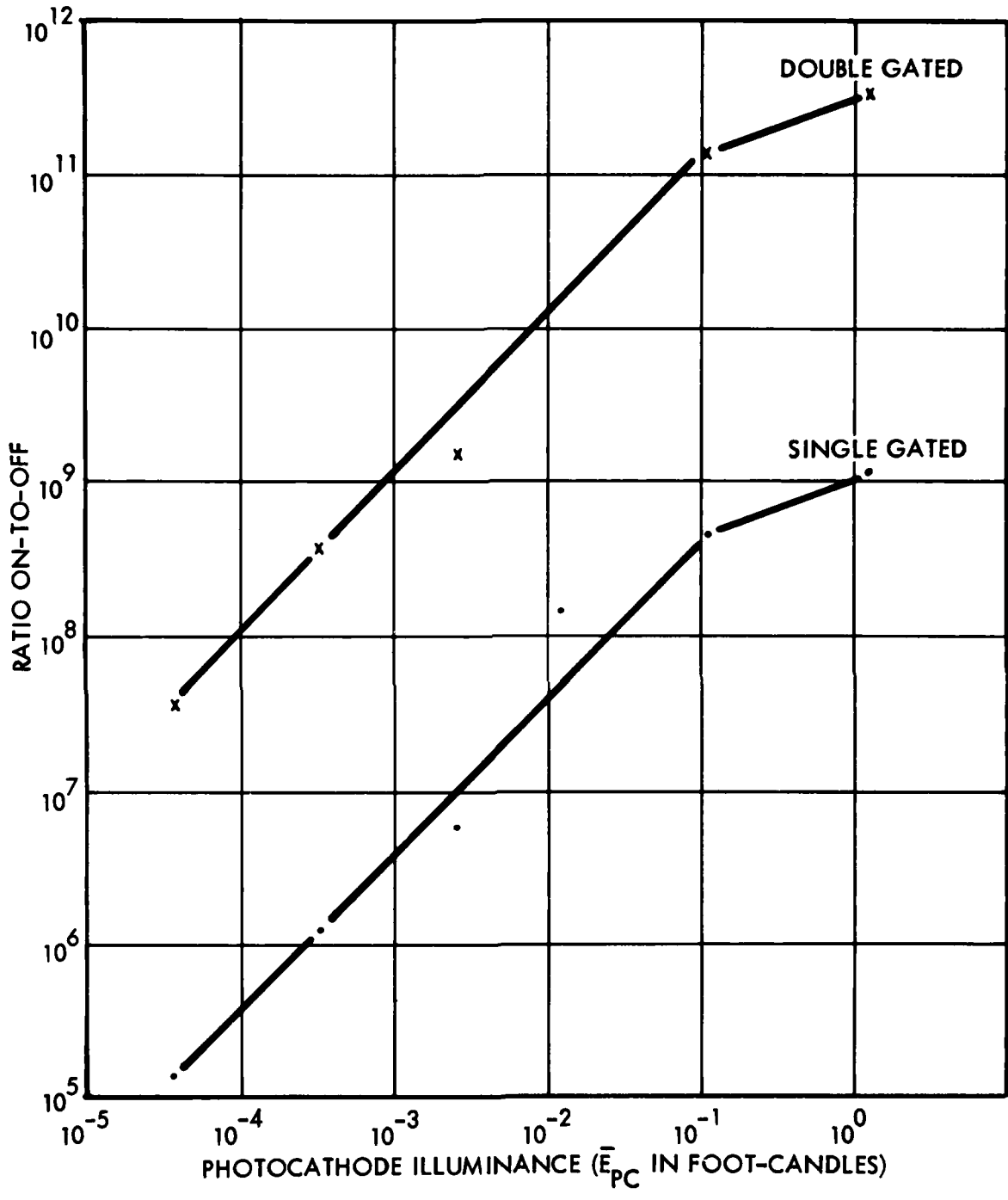

Figure 5. Predicted Hybrid Image Intensifier On-to-Off Ratio

D. Measured Performance of Hybrid Intensifier

First and second generation intensifiers were coupled and potted. The measured luminous gain (81.3K) compared favorably with predicted performance (87.7K). Measured EBI was 5.3×10^{-12} 1/cm² compared with a predicted value of 3.63×10^{-11} 1/cm². The reason for this difference has not been resolved. The photocathode response remains unchanged from the measurements made on the second generation intensifier.

The pulsed and dc off mode characteristics were also measured and results are shown in Figures 6 and 7. Comparison of the predicted to measured phosphor screen luminance (see Figure 4) reveals that the measured values of phosphor screen luminance are approximately an order of magnitude too high. Evaluation of the hybrid intensifier coupled to the vidicon showed several bright emission spots. Experimentation traced the emission spots to breakdown across the coupling of the two intensifiers. This region had a 5 kV potential gradient. Removal of the gradient significantly reduced the magnitude or eliminated the bright areas. These emission spots could be responsible for the measured high phosphor luminance. (For example, assuming a 0.1 mm diameter emission spot and a luminance of 0.1 foot-lambert at the coupling interface, the phosphor luminance would be ~10 foot-lamberts in the 0.1 mm spot. Considering the area of the phosphor viewed by the photometer, this spot would appear to be an additive phosphor luminance of 3.08×10^{-4} foot-lamberts.) The emission spots could explain the high phosphor luminance values at low light levels ($\bar{E}_{PC} < 1$ foot-candle). At higher light levels ($\bar{E}_{PC} > 1$ foot-candle), the ratio saturates. This is believed due to the second generation leaking problem discussed earlier. No pulsed tests were performed because of the LED emission decay characteristics discussed earlier.

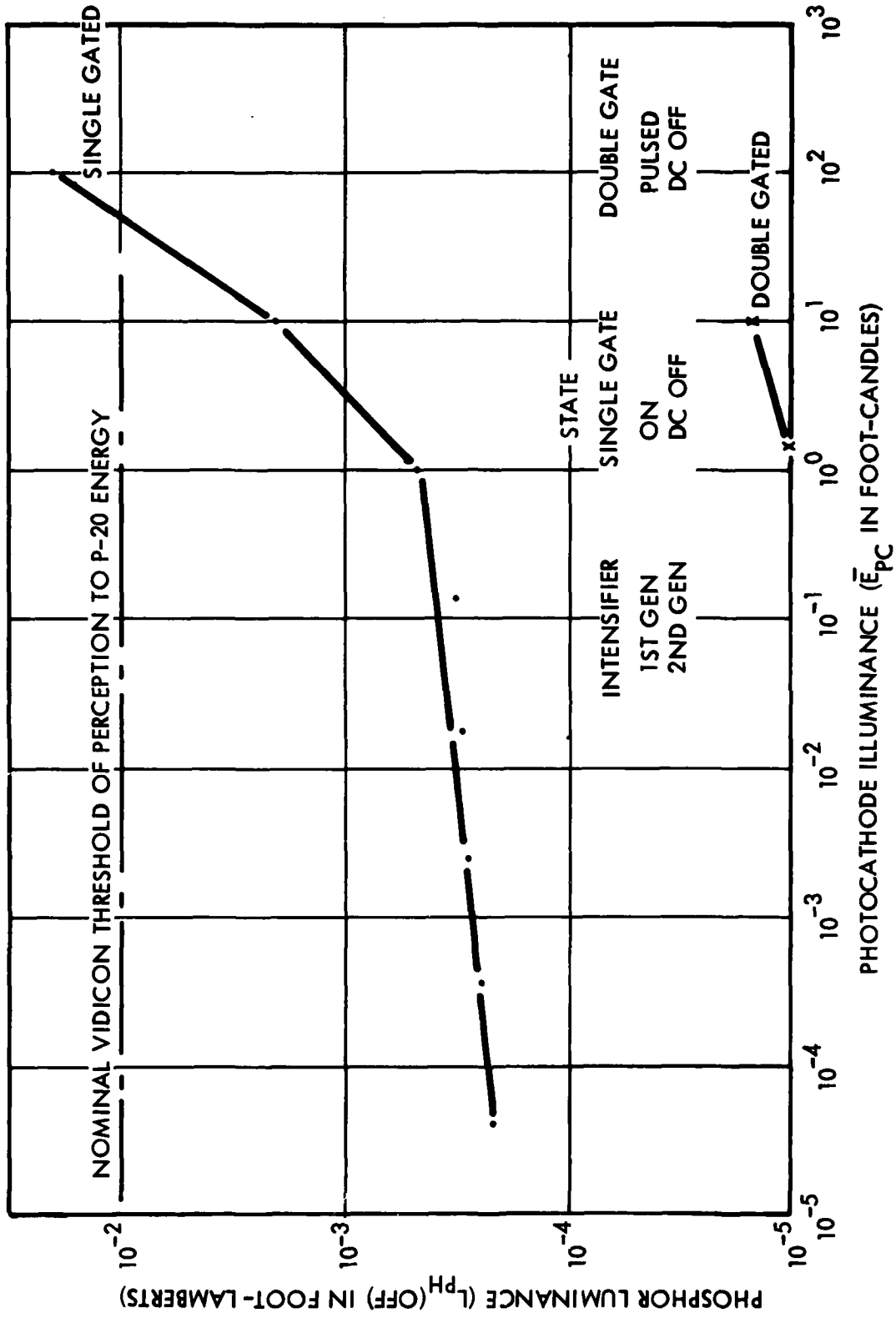

Figure 6. Measured Hybrid Intensifier Phosphor Screen Luminance versus Average Photocathode Illuminance for Single and Double-Gated Modes

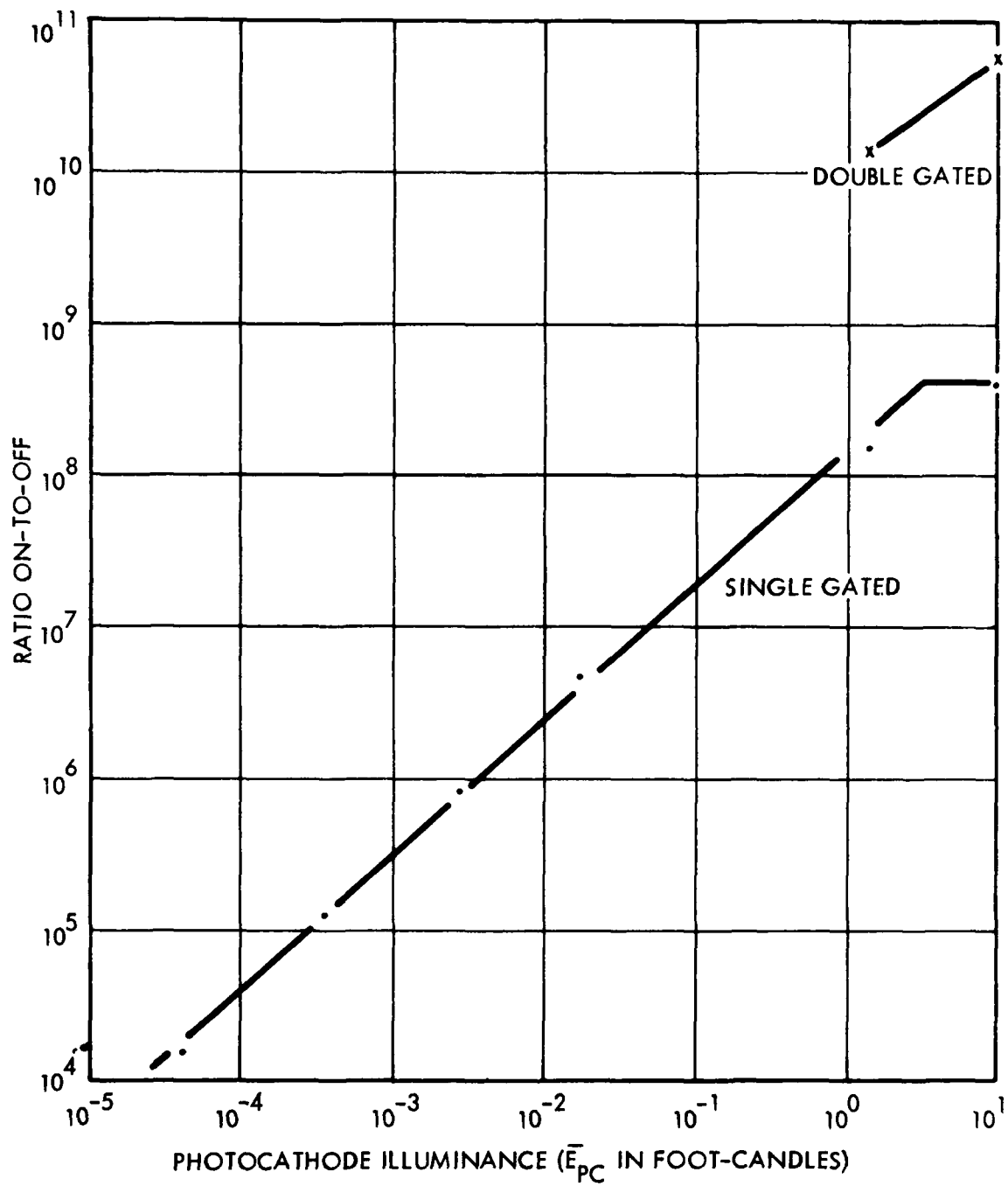

Figure 7. Measured Hybrid Image Intensifier On-to-Off Ratio for Single and Double-Gated Modes

E. Vidicon Tests

As previously mentioned, the hybrid intensifier emission spots were not observed until the intensifier was coupled to the vidicon tube. Before decoupling the intensifier from the vidicon, it was decided that grounding and EMI problems should be minimized and the external high voltage divider changed to eliminate the potential across the fiber optics. When these problems were resolved, a 100% contrast resolution measurement was made. Preliminary measurements indicated a maximum resolution of 600 television lines per picture height in both the ungated and pulsed modes. This resolution will correspond to a limiting angular resolution of approximately 20 microradians, or correspondingly 25 line pairs per milliradian.

Further testing of the double gating concept will be delayed until an operating GaAs Illuminator becomes available. Testing with an actual illuminator will allow measurement of the maximum attenuation of 0.85 micron energy that the double-gated intensifier will provide in the pulse-gated mode. This information can then be used to determine how low the reflectance and/or back scattering from common aperture mirrors and windows must be to maintain full camera performances.

Further camera testing will be performed during the subsystem tests prior to final CATIES system assembly.

III. SCHEDULE

During the current reporting period, the program schedule (refer to Figure 8) has been revised to match the current funding schedule. The revised schedule has a relatively minor impact on the program during the current fiscal year. A 5 or 6-week slowdown will be initiated during January and February. This additional time prior to detail system design may be beneficial since more detailed information on the FLIR and laser designator selection should be available 6 weeks from now. Beginning in late February, the original schedule will be resumed and maintained throughout the detail design of the system. If additional funding or other circumstances warrant, at the end of this calendar year the program could be continued at the originally planned pace and completed within a few weeks of the original schedule. If a continued stretch is necessary, the fabrication will be performed in a serial, task-by-task manner stretching the program over an additional eleven months. It is felt that a stretch during the fabrication phase will not have a detrimental effect on the cohesiveness or continuity of the system development. A similar stretch during the detail system design phase could have this effect, and will be avoided. Following fabrication, system test and evaluation will be performed at the rate and level of effect originally planned.

COMMON APERTURE TECHNIQUES
FOR
IMAGING ELECTRO-OPTICAL SENSOR (CATIES)
R&D STATUS REPORT NO. 7

I. GENERAL

This seventh R&D Status Report describes the activities of GE/AESD in the development of the Common Aperture Techniques for Imaging Electro-Optical Sensors (CATIES) Program under Contract F33615-76-C-1135, Item No. 0002, CDRL Sequence 2.

II. GATING STUDY

A. Test Results

During this report period, additional testing was conducted on the hybrid tube by itself and coupled with the high resolution focus projection scanning (FPS) vidicon. During the coupled tests, a high voltage arc (either in the external divider network or first generation tube gate output) damaged the wafer tube and the second stage intensifier gating supply. Prior to this failure, a limiting resolution of 600 TV lines per picture height had been measured in both passive operation and single second generation gating. Subsequent testing of the hybrid tube revealed that despite several burns in the wafer tube and in areas near the outside edge of the phosphor surface (from which the aluminized layer had been pulled away), the tube could still be operated at full bias voltage. No apparent damage was sustained by the second stage triode intensifier. If a gallium arsenide illuminator becomes available, the hybrid tube may still be useful for evaluating effects of 0.85 micron wavelength light with a common aperture window.

In the last monthly report, it was noted that the wafer tube in dc cutoff appeared to be "leaking" at white light input levels above one foot candle; that is, the on-off ratio saturated at higher light levels either because electrons were reaching the channel plate and being amplified, or white light was passing through the wafer tube and being amplified by the second stage intensifier. A test was conducted with the damaged hybrid tube with no bias voltages applied to determine which effect was responsible for saturation. The wafer tube photocathode was connected to the micro channel plate (MCP) input through an ammeter. No voltage was applied to either electrode. For input light levels as high as 50,000 foot candles, no signal current was detected in this dc gated-off mode. This test indicates that the maximum on-off ratio of the single-gated hybrid tube in the operational system configuration is limited only by the transmission of the wafer tube and the second stage photocathode sensitivity to 0.85 micron light.

An alternative to double-gating that may now be considered as a result of this testing is to process a second stage tube without cesium, which provides the red sensitivity of a S-20 photo surface. Tube response would fall off at 0.65 microns and provide no photocathode sensitivity.

In the following paragraphs, a sample calculation is made of the reflectance that can be tolerated from optical elements common to both the illuminator and LLTV receiver.

B. Sample Common Element Reflectance Calculation

In this section, a calculation is made of the average amount of energy reaching the vidicon during the "off" time, as a result of reflections from the common aperture elements (assumed to be a single window as shown in

Figure 1). Since final data on the hybrid intensifier and optics configuration is not complete, several assumptions have been made as follows:

1. Pulsed and dc "off" characteristics on the hybrid intensifier are identical.
2. Light striking the first generation tube photocathode during the gated-off interval is determined by the transmission of the wafer tube, which measured approximately 10^8 .
3. Energy reflected by the window is collected and focused uniformly across the intensifier photocathode.
4. Common aperture window reflectance is 0.1.
5. Camera optics transmission is 0.70.
6. Illuminator power is 30 watts.
7. Nominal vidicon threshold of perception is 0.01 foot lamberts from a P-20 phosphor.

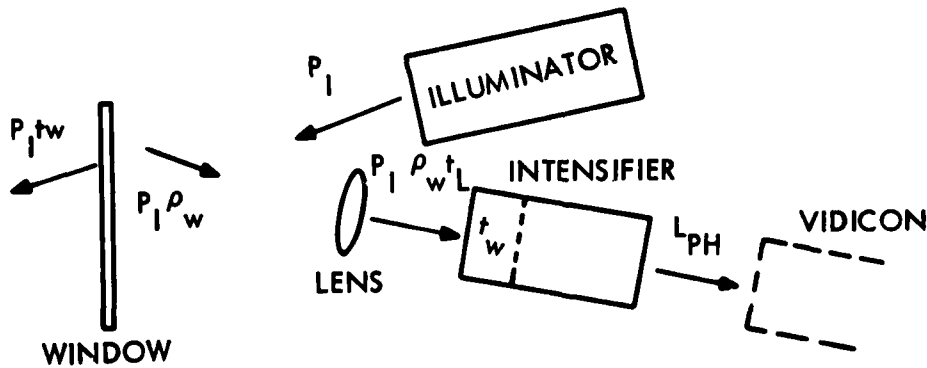

KEY: SYMBOL	DEFINITION	VALUE
P_i	ILLUMIATOR POWER	15w
t_w	WINDOW TRANSMISSION	
ρ_w	WINDOW REFLECTANCE	0.1
t_L	LENS TRANSMISSION	0.70
t_w	WAFER TRANSMISSION	10^{-8}
L_{PH}	PHOSPHOR LUMINANCE	7.4×10^{-3} FOOTLAMBERTS

Figure 1. Optics/Intensifier Configuration for Active TV

Referring to Figure 1, the amount of reflected energy, F_{850} , which strikes the second photocathode is given by

$$F_{850} = P_I \cdot P_w \cdot t_L \cdot t_w \quad (1)$$

The photocathode irradiance H_{850} is given by

$$H_{850} = F_{850}/A_{PC} = P_I \cdot P_w \cdot t_L \cdot t_w/A_{PC}. \quad (2)$$

Substituting numerical values into equation (2) yields

$$\begin{aligned} H_{850} &= (30w)(0.1)(0.70)(10^{-8})/(2.83 \times 10^{-3} \text{ FT}^2) \\ &= 7.4 \times 10^{-6} \text{ w/FT}^2 \end{aligned}$$

The photocathode current density, i_{PC} , for the second stage tube is given by

$$\begin{aligned} i_{PC} &= H_{850} \cdot S_{850} \text{ where } S_{850} \text{ is the photocathode response} \\ &\text{at 850 nanometers} \end{aligned} \quad (3)$$

Substituting numerical values into equation (3) yields

$$\begin{aligned} i_{PC} &= 7.4 \times 10^{-6} \text{ w/FT}^2 (2.0 \times 10^{-3} \text{ A/W}) \\ &= 1.48 \times 10^{-8} \text{ A/FT}^2 \end{aligned}$$

The equivalent photocathode illuminance, \bar{E}_{PC} , can be found by dividing the current density, i_{PC} , by the photocathode luminous sensitivity, S_L .

$$\begin{aligned} \bar{E}_{PC} &= i_{PC}/S_L \\ &= 1.48 \times 10^{-8} \text{ A/FT}^2 / 2.0 \times 10^{-4} \text{ A/L} \\ &= 7.4 \times 10^{-5} \text{ L/FT}^2 \end{aligned}$$

For a luminous gain (G_L) of 100, the hybrid tube output phosphor luminance (L_{ph}) can be calculated in the following manner:

$$L_{ph} = \bar{E}_{PC} \cdot G_L$$

Therefore, for single gating $L_{ph} = 7.4 \times 10^{-3}$. Since the vidicon threshold of perception is 10^{-2} foot candles (assumption 7 above), the initially assumed 10% window reflectance can be increased to 13.5% before the vidicon minimum detection threshold is reached.

Since the output phosphor luminance (L_{ph}) with double gating was measured to be at least three orders of magnitude lower, even a mirror coating (100% reflectance of laser energy) on the common aperture window would not be detected by the camera during the gate-off period if this technique were utilized. It is felt, however that adequate attenuation can be achieved without resorting to the double gating technique. The phosphor luminance at the vidicon interface can be maintained below 0.01 foot lamberts by specifying a minimum transmission for the wafer tube and/or by obtaining a second stage intensifier with little (less than 2.0 ma/watt) or no response at the illuminator wavelength.

III. SUMMARY

With the exception of tests performed with an actual illuminator system, tests of camera system attenuation during camera off times have been completed. As a result of the tests performed, it is believed that at least two methods exist (double gating and single stage MCP gating with modified second stage photocathode) which produce sufficient gated-off attenuation to reject back reflected illuminator energy.

During the next reporting period, some preliminary system design will begin, and the Optics Specification and Work Statement will be reviewed with prospective optical design subcontractors.

COMMON APERTURE TECHNIQUES
FOR
IMAGING ELECTRO-OPTICAL SENSOR (CATIES)
R&D STATUS REPORT NO. 8 AND 9

I. GENERAL

This eighth and ninth R&D Status Report describes the activities of GE/AESD in the development of the Common Aperture Techniques for Imaging Electro-Optical Sensors (CATIES) Program under Contract F33615-76-C-1135, Item No. 0002, CDRL Sequence 2. Due to the program stretch for funding increments, activity during the month of February was light, and is combined with March activity in this Status Report.

II. IN-PLANT PROGRAM REVIEW

On 10 and 11 March, a on-site program review was held to review the status of the program and discuss suggested modifications to the hardware development plan. Mr. Donald Learish, AFAL Project Manager, attended these meetings. It was recommended at this time that the thermal imaging system to be utilized on CATIES be changed from the AN/AAQ-9 to a "MINI-FLIR" Serial Scan system. The reasons for this change were:

1. To avoid further delays in waiting for a PAVE TACK FLIR Selection.
2. To reduce the overall CATIES package size and cost by utilizing the smaller FLIR.

Also recommended was the change from a liquid nitrogen cooled Ga As laser illuminator to a metal vapor laser. The reasons for this recommendation were:

1. To ease the optical system design problem associated with the lower radiance Ga As illuminator.

2. To eliminate the need for cryogenic cooling.
3. To permit ATV operation in the 20 mrad field of view with full illuminator power.

The recent award of a development contract for the lead vapor laser from AFAL/TEO to General Electric Space Science Laboratory was a factor in this recommendation.

The in-plant review also included demonstration of the CATIES TV Camera, and the R.F.E.O. Strike Nose hardware.

III. AFAL PROGRAM REVIEW

On March 15, a Program Review was held at AFAL to review the status of the program, and to review our change recommendations. It was recommended by Colonel Wallace that we proceed with plans to implement the contract changes.

On March 25, a meeting was held with Honeywell engineers at Lexington, Mass. to discuss the possibility of incorporating a MINI-FLIR into the CATIES system. It was determined that the MINI-FLIR would have lower resolution than the AN/AAQ-9 in the CATIES 6.5 inch aperture, but would have slightly higher thermal sensitivity. Use of the MINI-FLIR in a 6.5 inch aperture would require a new IR telescope design. If the present 4.5 inch IR aperture were used, the existing IR telescope design could be utilized. This would result in a somewhat lower performance, but could reduce the size of the system pointing mirror significantly. The final decision on which way to go should be made by the Air Force prior to letting the OPTICS subsystem subcontract. A meeting to discuss this and other program issues is scheduled for 22 April 1977.

IV. OPTICS SUBSYSTEM SPECIFICATION AND WORK STATEMENT

The optics subsystem specification and work statement are being held until a decision on the FLIR system is reached. A preliminary copy of the specification has been forwarded to prospective bidders for review.

V. ILLUMINATOR/TV CAMERA TESTS

During this period the lead vapor illuminator was operated with the CATIES gated television camera in a field test. The illuminator was found to be quite uniform $\pm 10\%$ over the 3° field of view, and also found to be free of coherence speckle. Under an internal development program, the design and construction of a sealed off lead vapor illuminator has begun.

VI. NEXT REPORTING PERIOD

During the next reporting period the final RFQ for the optics subsystem should be released. Some additional camera tests will also be performed.

COMMON APERTURE TECHNIQUES
FOR
IMAGING ELECTRO-OPTICAL SENSORS (CATIES)
R&D STATUS REPORT NO. 10

I. GENERAL

This tenth R&D Status Report describes the activities of GE/AESD in the development of the Common Aperture Techniques for Imaging Electro-Optical Sensors (CATIES) Program under Contract F33615-76-C-1135, Item No. 0002, CDRL Sequence 2.

II. PROGRAM REVIEW

On May 11 and 12, briefings were held at AFAL to review the work performed to date and plan for the remainder of the program. Topics addressed in detail included the following:

1. Active TV and Day Camera performance.
2. Lead Vapor Illuminator impact on system performance.
3. FLIR and TV performance in CATIES configuration.
4. Review and update of Mission/Scenario Analysis presented in the CATIES proposal.
5. Review of Optical Specification and Statement of Work (SOW).
6. CATIES FLIR Considerations (PAVE TACK vs MINI-FLIR).

Following the meetings, it was decided that GE/AESD should release the Optical subcontract Specification and Statement of Work which will include the requirements for integration of the metal vapor laser, and either the Honeywell AN/AAQ-9 FLIR or the Honeywell MINI-FLIR with 6.5 inch telescope. It was stated that the contract modifications permitting use of the new illuminator would follow.

III. PLZT ELECTRO-OPTIC AUTOMATIC LIGHT CONTROL (ALC) EVALUATION

A silicon vidicon camera was obtained and various sheet polarizers were evaluated for their ability to extend the useful operating light range of this sensor. Only the Polaroid HR type (0.75 to 3 micron spectral region) could be used with no additional filtering, but only between 20 or 30 to 1 light control is attainable with this material. Approximately 150 to 1 range in light control was achieved with HN-32 visible polarizers (0.4 to 0.8 microns), but a 3 mm thick KG-3 (red absorbing) filter was required. Maximum transmission of this filter combination is only 0.025 or one-fifth (1/5) of the HR type.

Other findings as a result of this evaluation are as follows:

1. The conductive coating (interdigital pattern) must be aligned and applied to both sides of the ceramic disk for a full range of light control.
2. No measurable resolution loss can be detected when the ceramic disk is in the optical path of the silicon vidicon camera.
3. The ceramic disk must be at least 0.5 inches in front of the camera faceplate (image plane) so that no shaded bars or non-uniformities from the applied conductive pattern are observable in the displayed video on the monitor.

During the preliminary optical design effort, this automatic light control device will be considered along with other more conventional techniques such as iris, neutral density filters etc. to determine the most effective, from an overall system performance point of view.

IV. OPTICS SUBSYSTEM SPECIFICATION AND STATEMENT OF WORK

Recommended changes and suggested improvements received from prospective bidders have been reviewed and, where appropriate, the specification and SOW have been modified. These documents have been forwarded to subcontracts for release.

V. ILLUMINATOR DEVELOPMENT

The design and construction of a sealed off lead vapor illuminator under an internal development program is continuing. No glass to metal failures have been recorded, but traces of deposits on windows indicate that a more even temperature distribution is required before a successful lasing action can be achieved. Present efforts are directed at optimization of heat shielding techniques within the device to elevate the window temperature from its present 800°C to 1000°C.

IV. NEXT REPORTING PERIOD

During the next reporting period it is expected that subcontractor proposals for the preliminary and detailed design of the optical assembly will be received. Also, an effort will be directed at identifying the electrical interfaces between the CATIES system components.

R&D STATUS REPORTS

No. 11 through No. 19

PHASE II

SYSTEM DESIGN

May 1977 through June 1978

COMMON APERTURE TECHNIQUES
FOR
IMAGING ELECTRO-OPTICAL SENSORS (CATIES)
R&D STATUS REPORT NO. 11

I. GENERAL

This eleventh R&D Status Report describes the activities of GE/AESD in the development of the Common Aperture Techniques for Imaging Electro-Optical Sensors (CATIES) Program under Contract F33615-76-C-1135, Item No. 0002, CDRL Sequence 2.

II. OPTICS SUBSYSTEM

During this report period, the Optics Subsystem Specification and Work Statement were finalized and sent to prospective bidders. Copies were sent to five companies who had previously indicated an interest in the program.

These companies are as follows:

- Alpha Optics
- Kollmorgan, Electro-Optics Division
- Tropel Optics
- Perkin Elmer, Norwalk
- Tinsley Optics

Tropel and Tinsley elected not to bid the program due to internal scheduling conflicts. Kollmorgan submitted a cost and management proposal but no technical proposal, and were thus disqualified.

Full proposals were received from Alpha and Perkin Elmer. These proposals are currently being reviewed by AESD and Air Force engineers. A selection is to be made early in August.

Image Derotation

An image derotating prism assembly designed for RFEO Strike Nose (internal development program) is being evaluated for possible inclusion in CATIES. This is being considered as an alternative to derotation of the day and night camera heads. The principal advantages and disadvantages of the two approaches are indicated as follows:

Prism (Optical) Derotation Approach

<u>Advantages</u>	<u>Disadvantages</u>
Single derotator works for two camera heads	Complicates optical chain by requiring collimating space
Higher bandwidth rotation achievable due to lower inertia and lower friction	Decreases overall system MTF and resolution (currently being evaluated)

Camera Head Derotation Approach

<u>Advantages</u>	<u>Disadvantages</u>
No special provisions required in optics chain	Complicated mechanically
Alignment may be simple	Low bandwidth - suitable for tower test, but probably not flight test

The design cost of the two approaches is approximately the same, and the decision will be reached in the weighing of technical factors.

COMMON APERTURE TECHNIQUES
FOR
IMAGING ELECTRO-OPTICAL SENSORS (CATIES)
R&D STATUS REPORT NO. 12

I. GENERAL

This twelfth R&D Status Report describes the activities of GE/AESD in the development of the Common Aperture Techniques for Imaging Electro-Optical Sensors (CATIES) Program under Contract F33615-76-C-1135, Item No. 0002, CDRL Sequence 2. This report also marks the transfer of CATIES Project Engineering responsibility from Louis Lego to James Juliano (Extension 5319), although Mr. Lego will continue to assist during this transitional period.

II. OPTICS SUBSYSTEM

During this report period, proposals were reviewed from Alpha Optical and Perkin Elmer. Letters with questions and requests for additional clarification were forwarded to each vendor. Copies of both the GE/AESD letters and vendor responses will be forwarded to the Air Force under separate cover. During the week of 15 August 1977, Alpha Optical and Perkin Elmer are scheduled to visit GE/AESD for technical discussions. Final vendor selection will be made during the week of 22 August 1977.

Image Derotation

The image derotation prism assembly designed for RFE0 Strike Nose has been evaluated for possible inclusion in CATIES. It was determined that overall system alignment and resolution performance was limited by

fabrication errors in the derotation assembly. Specifically, a 55-second decentration was measured in the collimating optics. This misalignment of the output optical axis in respect to the mechanical axis is normally eliminated at the collimator input, by reworking a flat plate element into a wedge configuration to compensate for the measured offset. Due to a lack of funding, these final steps were not originally completed in the Strike Nose system. Also, considerable astigmatism detected in the collimating optics is attributed to the fabrication/installation of one or more elements in this assembly. An optimum alignment was achieved (limited only by collimator decentration) with the derotation/turret combination. All test procedures were recorded to enable duplication, as necessary, in the fabrication and alignment of the CATIES System. Relatively minor mechanical problems were found in the assembly but optical performance was not affected. These problems have been recorded so that appropriate changes can be incorporated in the CATIES system, if this configuration is compatible with the final optical subsystem concept.

III. IMAGE INTENSIFIER

As reported in the seventh monthly status report, a high voltage arc damaged the intensifier wafer tube. The wafer tube was useful for laboratory testing; however, for field testing, it is unreliable and a replacement should be obtained.

Recent discussions with Varian Associates, Inc., Palo Alto, California, have indicated that third generation image intensifiers (Gallium Arsenide photocathodes) are now being built for the US Army, Night Vision Laboratory, Ft. Belvoir, Va.

The added sensitivity, when coupled with significantly lower noise currents measured thus far, could result in a camera 30 to 50 times more sensitive than present wafer tubes permit. Although exhibiting more sensitivity, the Varian devices require a higher gating voltage than provided for conventional wafer tubes. The ITT tube looks more promising for CATIES at this time since the elements are spaced closer. Consequently, it is expected that lower gating voltages similar to those currently being provided for the hybrid intensifier will be required. GE/AESD is investigating the possibility of obtaining one of these devices for evaluation purposes and determining its suitability for use in CATIES. The time frame for the development of these devices is consistent with the CATIES program, since operating life of these photocathodes is already comparable to S-20 photosurfaces, and production is scheduled to begin in 1980.

High Voltage Gating Modules

GE/AESD is in the process of procuring (with Capital Equipment Funds) two gating power supplies. The devices, which are a wrap-around configuration, are compatible with hybrid intensifiers and are intended for minimizing the risks of incurring permanent intensifier damage (due to arc overs) when testing, evaluating and demonstrating intensifier/camera capabilities in the lab or field. These modules should be available in approximately eight weeks for use in CATIES as well as other programs in house.

COMMON APERTURE TECHNIQUES
FOR
IMAGING ELECTRO-OPTICAL SENSORS (CATIES)
R&D STATUS REPORT NO. 13

I. GENERAL

This thirteenth R&D Status Report describes the activities of GE/AESD in the development of the Common Aperture Techniques for imaging Electro-Optical Sensors (CATIES) Program under Contract F33615-76-C-1135, Item No. 0002, CDRL Sequence 2.

II. OPTICS SUBSYSTEM

Optics subsystem procurement has been delayed to permit time for additional fact finding deemed necessary for maintaining overall program control. Clarifications of bidders' technical proposals on Phase I and Phase II efforts were obtained in the post-submittal meetings and subsequent documentation. "Not-to-exceed" estimates on Phase III, Hardware Fabrication, are expected in-house during the week of 19 September. These inputs will permit completion of the contract in the most cost effective manner. The optics subcontract is expected to be let during the week of 26 September.

III. GATING STUDY

The CFE night camera is being assembled with a CFE intensifier. This intensifier can be used in place of the intensifier which was bought with contract funds and damaged during the gating study. Test results will be included in next month's report.

IV. MEETINGS

During this reporting period, a meeting was held 1 September at WPAFB to review the status of the program. Several action items were established at this meeting.

AFAL Action Items

1. Provide to GE/AESD the FLIR performance comparisons data.
2. Provide to GE/AESD the information on Tower Test facilities.
3. Contact NSWC, Dahlgren Labs, re Pre-Display Video Processor and evaluate its potential application to Tower Testing.
4. Contact NVL on the status of III-V photocathode development and determine the availability of a third generation intensifier with a microchannel plate.

GE/AESD Action Items

1. Provide AFAL with a monthly expenditure estimate (based on the latest actuals) and an estimate for the last week. This expenditure estimate is to be phoned on the last calendar day of the month.
2. At the PDR, provide recommendations on which PAVE TACK FLIR should be used on CATIES, and on testing the CATIES system in the Tower.
3. Provide information on the Pre-Display Video Processor and the CFE Camera.

COMMON APERTURE TECHNIQUES
FOR
IMAGING ELECTRO-OPTICAL SENSORS (CATIES)
R&D STATUS REPORT NO. 14

1. GENERAL

This fourteenth R&D Status Report describes the activities of GE/AESD in the development of the Common Aperture Techniques for Imaging Electro-Optical Sensors (CATIES) Program under Contract F33615-76-C-1135, Item No. 0002, CDRL Sequence 2.

II. OPTICS SUBSYSTEM

The contract for Phase I and II of the optical subsystem design was awarded to Perkin-Elmer, Norwalk at the end of September and a meeting was held at GE on 7 October. The purpose of this meeting was to establish a preliminary schedule, list priorities and review performance tradeoff areas identified in the Statement of Work, Revision A dated 6 September (see Attachment 1).

A second meeting was held at the Perkin-Elmer Facility on 18 October. Of the eight potential configurations considered, Perkin-Elmer has indicated that the common objective with three relay (turret) approach is the first choice for meeting the specification and Statement of Work requirements when both optical and mechanical aspects are considered. Attachment 2, Figures PY-1 through PY-13, identifies the various concepts and lists the advantages and disadvantages associated with each. Perkin-Elmer is of the opinion that the common objective approach is viable and offers the least risk provided that f-number and focal length values for one and/or both the wider fov's in

the TV optical path can differ from the values in the optical specification. These new values are indicated in Attachment 2, Figures PY-12 and PY-13. The impact of the proposed changes on system performance was assessed by GE. Further investigation by Perkin-Elmer revealed that only the changes in Attachment 2, Figure PY-13 would be required. Perkin-Elmer was directed to proceed with the first order design on the preferred common objective design. Sufficient information should be available at the time of the preliminary design review to evaluate how closely the values in the optical specification can be met. It was also determined at the 18 October meeting that optical derotation is not compatible with any of the concepts without significant changes to optical specification values thereby adversely affecting overall system size, weight and performance.

Proprietary Information Exchange

In order to proceed with the design of the FLIR VWF0V optics, up-to-date detailed drawings of the existing Honeywell optics must be supplied to Perkin-Elmer. An exchange agreement between Perkin-Elmer and GE has been drafted and forwarded to Norwalk for approval. The terms are the same as in the existing GE-Honeywell agreement. Updated information from Honeywell or the Air Force will be required during the next reporting period to proceed with the optical design as well as the mechanical and electrical interface. A meeting with the Pave Tack SPO is scheduled for the first week in November to obtain required information.

III. THERMAL ANALYSIS

The assumptions used in the thermal analysis for the spectral separator are listed in Attachment 3. A preliminary analysis, using the computer, indicated that for the assumptions made no degraded FLIR

performance is anticipated due to heating effects from the lasers. Perkin-Elmer has agreed to provide the characteristics of a reasonably attainable coating in light of the power densities and long term environmental degradation effects. Meanwhile, the analysis will be rerun for two other reflectance values and the results will be included in the next report.

IV. GATING TESTS

The test results for the CFE night camera were not obtained during the reporting period as previously indicated because of a defective ("gassy") intensifier module. Arrangements are currently being made to replace this unit and measured data will be included in the first monthly report after delivery of a new intensifier module.

NOTE: 3 attachments
att 1 - 1 pg
att 2 - 13 pgs
att 3 - 1 pg

ATTACHMENT 1 TO R&D STATUS REPORT NO. 14

TABLE 1. PERFORMANCE SPECIFICATION TRADE-OFF AREAS

Specification Paragraph	Description of Change
3.1.3	The overall length of the optical system may be increased.
3.2.1.1	The short wavelength cut-on may be changed from 0.55μ to 0.60μ or 0.65μ . In the day and night TV paths.
3.2.1.4	The plane of best focus for the 20 MR (UNFOV) may be focused at a distance less than hyperfocal.
3.2.1.5	The alignment between the 240 MR TV path and the 60 MR and 20 MR TV path may be relaxed. The alignment between the 440 MR FLIR path and the 240 MR and 60 MR FLIR path may be relaxed.
3.2.1.6	The F/No. for the night and day TV in the 240 MR and 60 MR fields-of-view may be relaxed.
3.2.1.8	The 65 LP/MM and 45 LP/MM modulus values in all fields-of-view may be relaxed. The modulus values in the 240 MR field-of-view may be relaxed to the values in the 20 MR field-of-view.
3.2.1.9	The relative illumination in all fields-of-view may be relaxed.
3.2.1.10	The full field distortion for all sensors may be relaxed.

ATTACHMENT 2 TO R&D STATUS REPORT NO. 14

Attachment 2 consists of Figures PY-1 through PY-13.

A. MULTIPLE OBJECTIVES

- (1) 3 OBJECTIVE - RELAY SYSTEMS IN TURRET
- (2) 2 OBJECTIVES IN TURRET AND 2 RELAYS IN TURRET
- * (3) 2 OBJECTIVES W/SWITCH MIRRORS AND 2 RELAYS IN TURRET

B. COMMON OBJECTIVES

- * (1) 1 OBJECTIVE AND 3 RELAYS IN TURRET
- (2) 1 OBJECTIVE AND 3 POSITION ZOOM RELAY
- (3) 3 POSITION ZOOM OBJECTIVE AND FIXED RELAY
- (4) 3 POSITION ZOOM OBJECTIVE AND 3 POSITION ZOOM RELAY

* APPARENT MOST FAVORABLE CONCEPTS

Figure PY-1. Concepts Considered for TV Optics

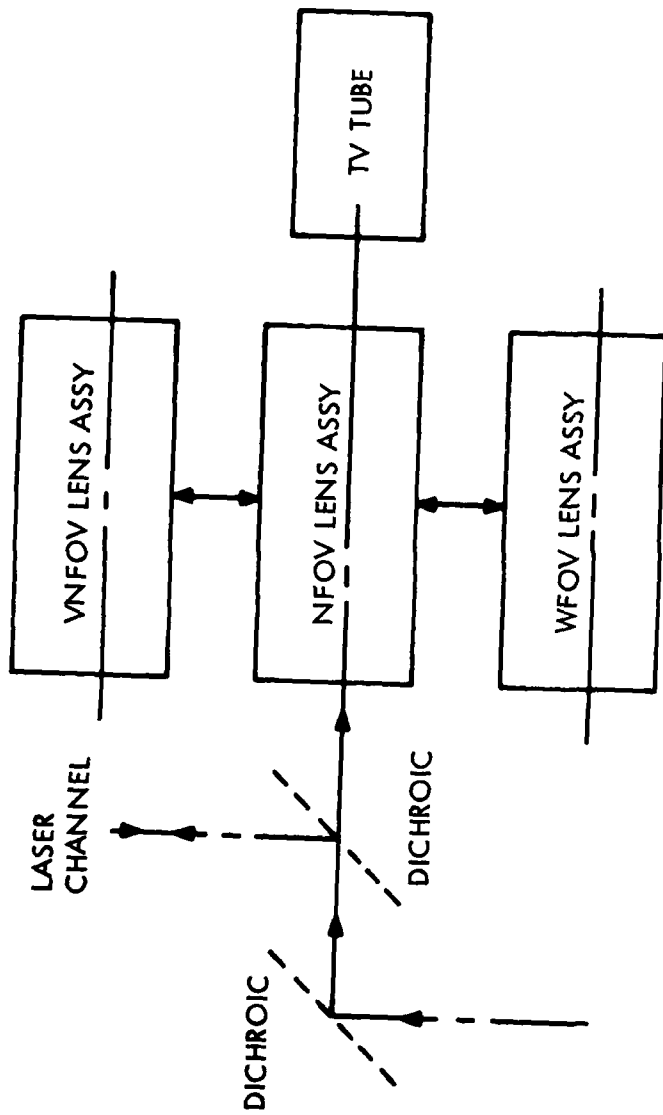

ADVANTAGES

1. GOOD PERFORMANCE EXPECTED THROUGH UNVIGNETTED FIELD
2. NO OPTICAL DESIGN "CROSSTALK" BETWEEN CHANNELS
3. LASER CHANNEL SIMPLIFIED — NO ANNULUS REQUIRED (FROM OPTICAL STANDPOINT ONLY)

DISADVANTAGES

1. THREE VERY LARGE ASSEMBLIES TO SWITCH (ONE TURRET)
2. POTENTIAL BORESIGHT ERRORS
3. MANY ELEMENTS — HIGH COST
4. MAXIMUM VOLUME OCCUPIED
5. VIGNETTING DUE TO UNFAVORABLE PUPIL LOCATION

Figure PY-2. Concept A(1) - 3 Objective - Relay Systems

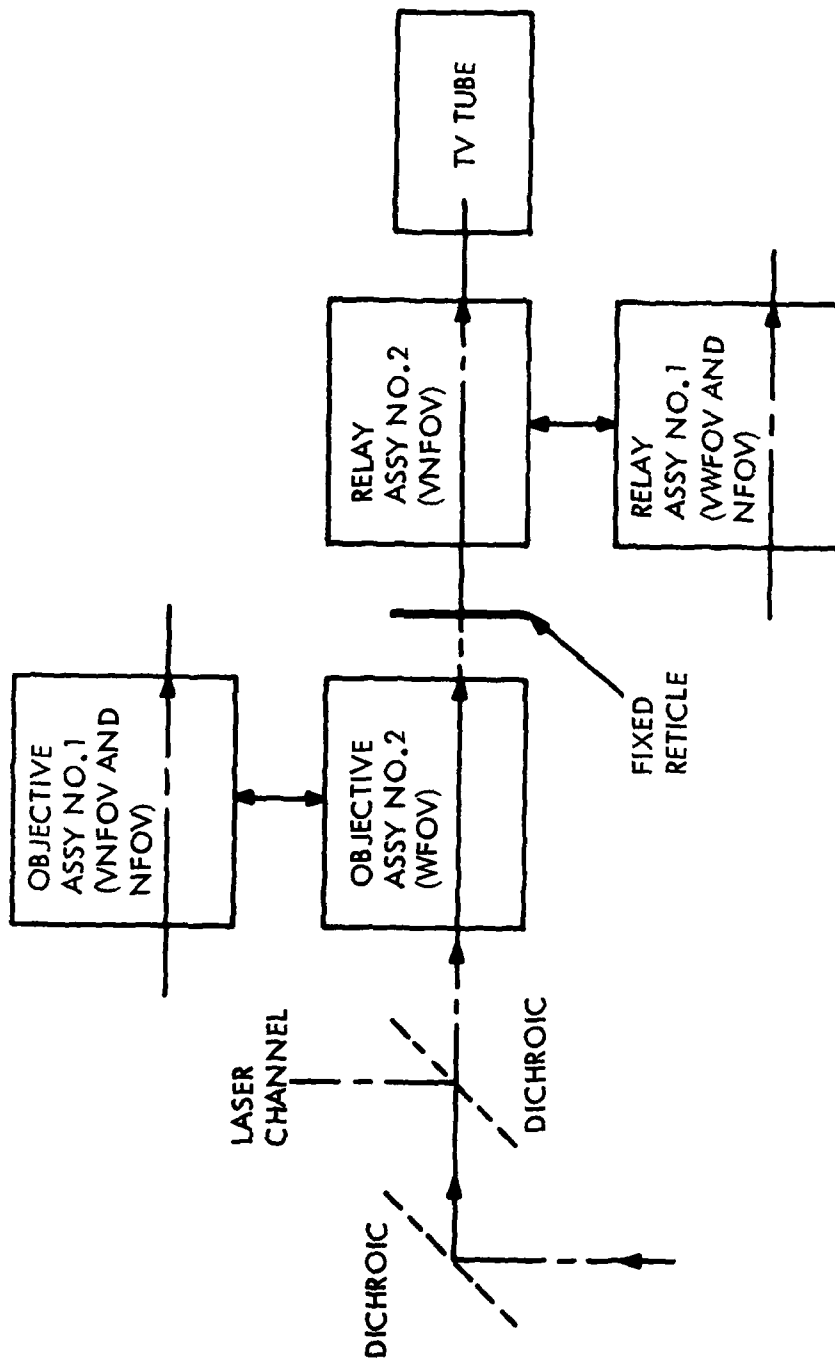

ADVANTAGES

1. ONLY SMALL COMPROMISE IN PERFORMANCE THROUGH UNVIGNETTED FIELD
2. LASER CHANNEL SIMPLIFIED - NO ANNULUS REQUIRED (OPTICAL ONLY)

DISADVANTAGES

1. FOUR LARGE ASSEMBLIES TO SWITCH (2 TURRETS)
2. POTENTIAL BORESIGHT ERRORS
3. MANY ELEMENTS → HIGH COST
4. LARGE VOLUME OCCUPIED
5. VIGNETTING DUE TO UNFAVORABLE PUPIL LOCATION
6. RELAYS MUST BE SWITCHED

Figure PY-3. Concept A(2) - 2 Objectives in Turret No. 1 and 2 Relays in Turret No. 2

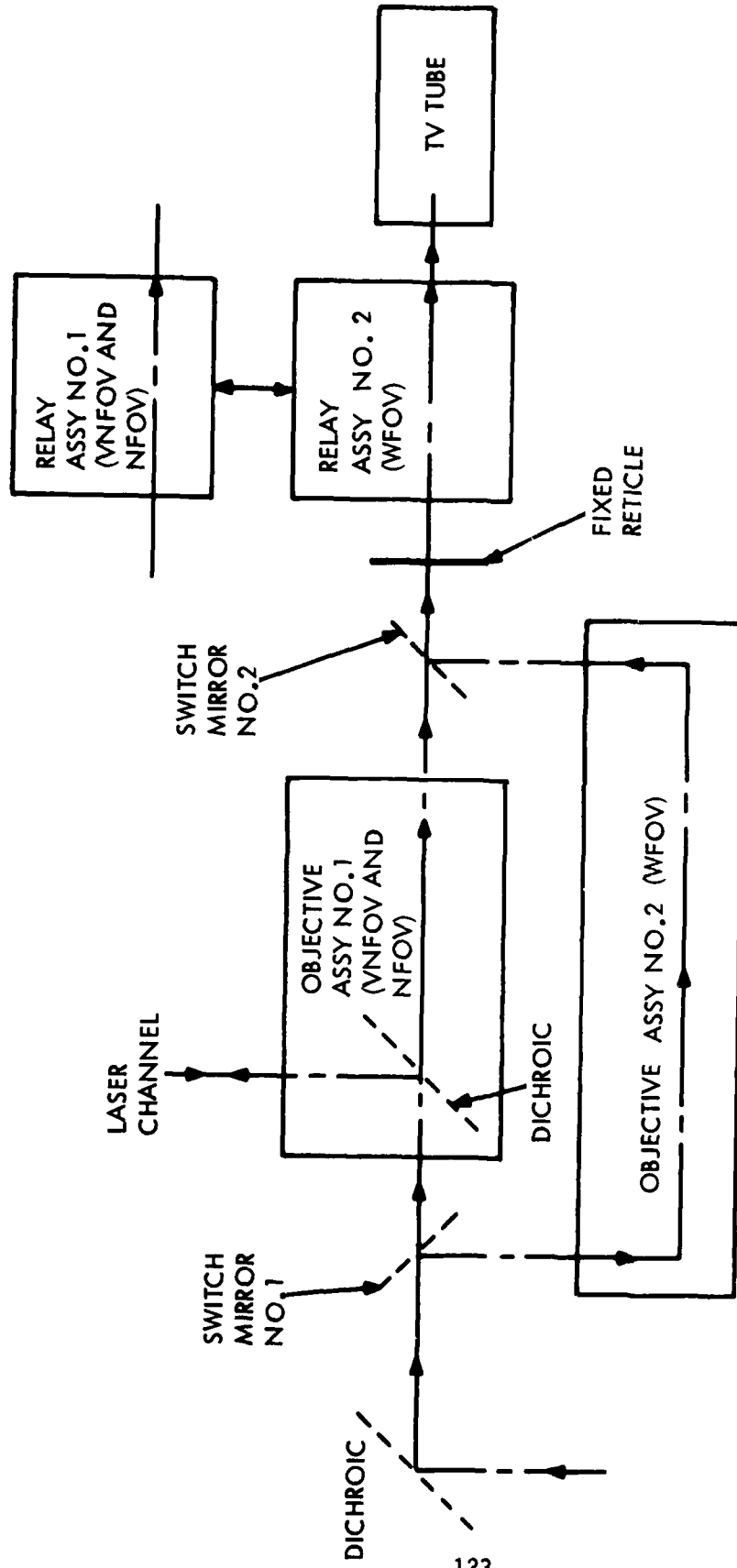

ADVANTAGES

1. SMALL MIRRORS SWITCH OBJECTIVES - CAN BE FAST
2. GOOD PERFORMANCE EXPECTED
3. FAVORABLE PUPIL LOCATION - LITTLE VIGNETTING
4. LASER CHANNEL SHARES LENS IN OBJECTIVE

DISADVANTAGES

1. POTENTIAL SMALL BORESIGHT ERRORS
2. MANY ELEMENTS - HIGH COST
3. LARGE VOLUME OCCUPIED
4. RELAYS MUST BE SWITCHED (ONE TURRET)
5. SOME OBSTRUCTION OF LASER BEAM

Figure PY-4. Concept A(3) - 2 Objectives with Switch Mirrors and 2 Relays in Turret

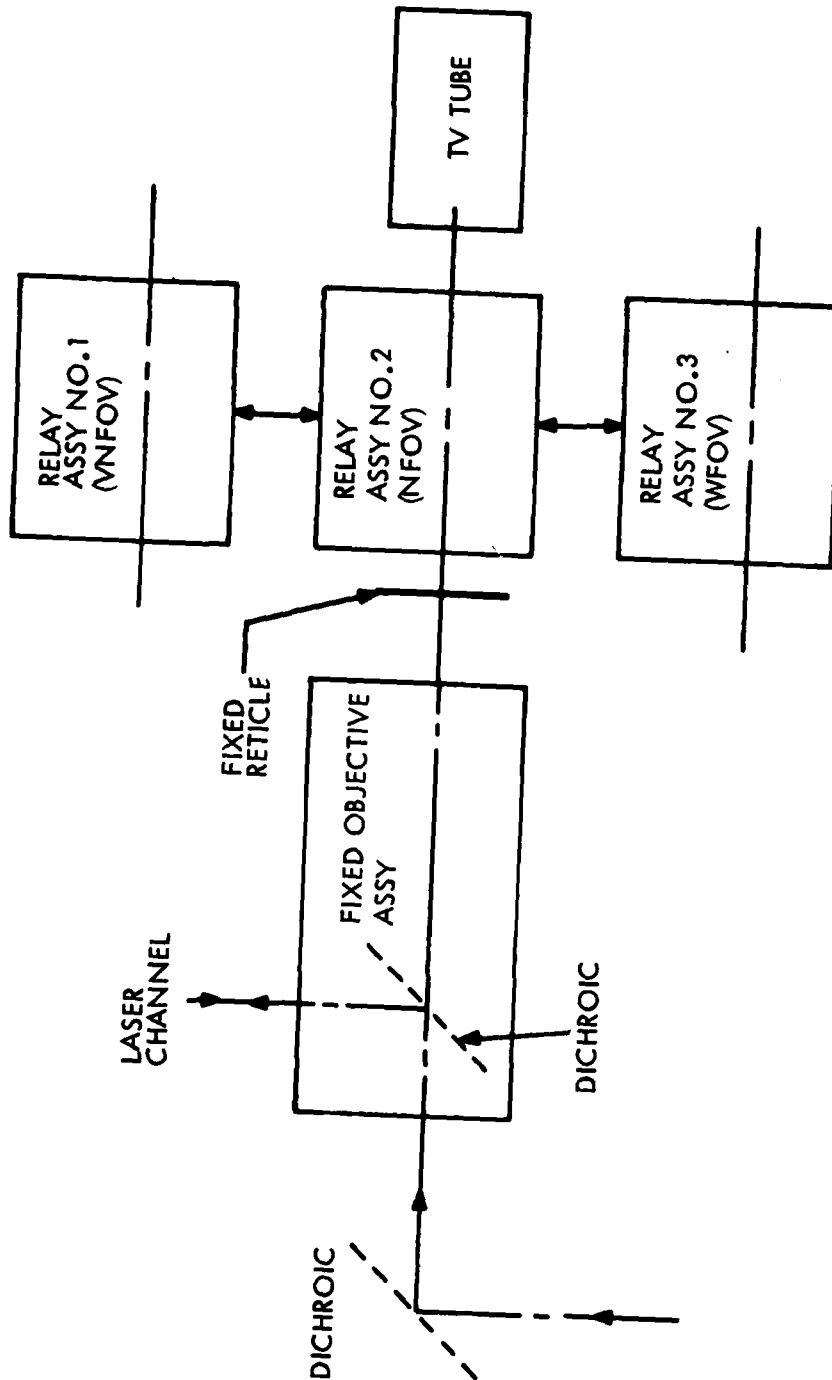

ADVANTAGES

1. NO NEED TO SWITCH OBJECTIVES -
2. NO BORESIGHT ERRORS
3. GOOD PERFORMANCE EXPECTED
3. FAVORABLE PUPIL LOCATION -
4. LITTLE VIGNETTING
4. LASER CHANNEL SHARES LENS IN OBJECTIVE
5. REDUCED COMPLEXITY

DISADVANTAGES

1. MODERATE VOLUME OCCUPIED
2. RELAYS MUST BE SWITCHED (ONE TURRET)

Figure PY-5. Concept B(1) - 1 Objective and 3 Relays in Turret

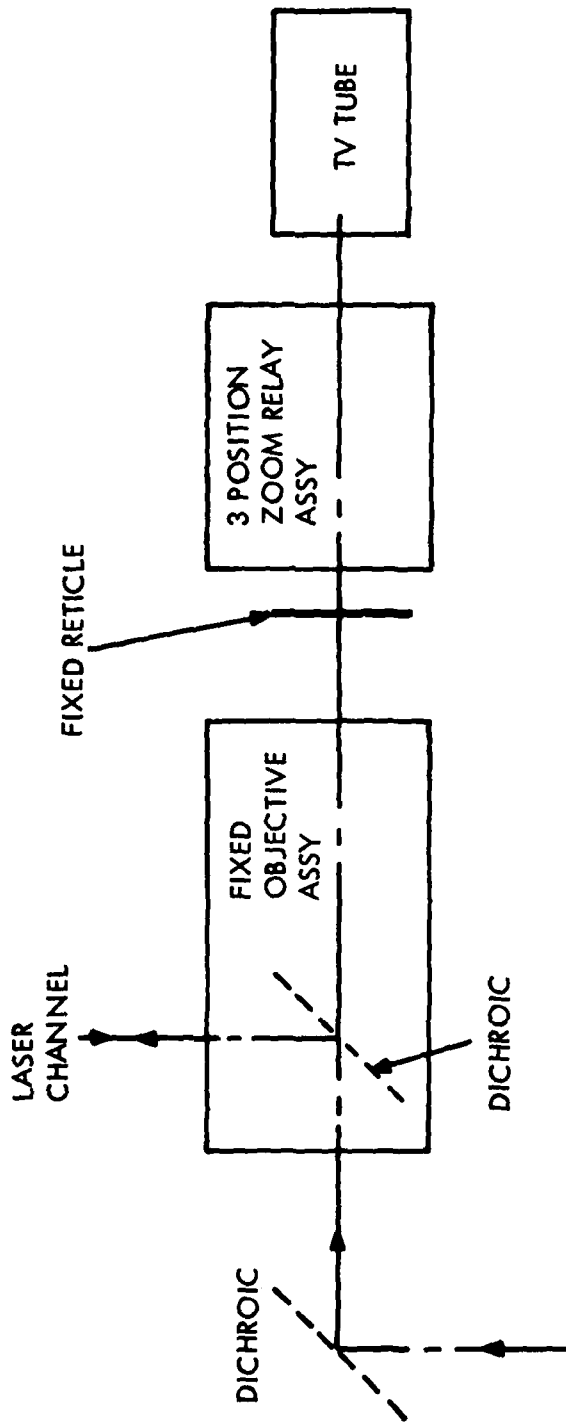

ADVANTAGES

1. NO NEED TO SWITCH OBJECTIVES -
2. NO BORESIGHT ERRORS
3. COULD HAVE CONTINUOUS ZOOM
3. LASER CHANNEL SHARES LENS IN OBJECTIVE
4. MINIMUM VOLUME OCCUPIED
5. CONSTANT TRANSMISSION
6. SIMPLE EXTERNAL CONFIGURATION

DISADVANTAGES

1. SERIOUS PERFORMANCE COMPROMISE - AFFECTS RESOLUTION AND DISTORTION
2. COMPLEX DESIGN (LONGITUDINAL SENSITIVE) → HIGH COST
3. VIGNETTING EXPECTED DUE TO MOVING PUPIL LOCATION
4. SENSITIVE TO TEMPERATURE

Figure PY-6. Concept B(2) - 1 Objective and 3-Position Zoom Relay

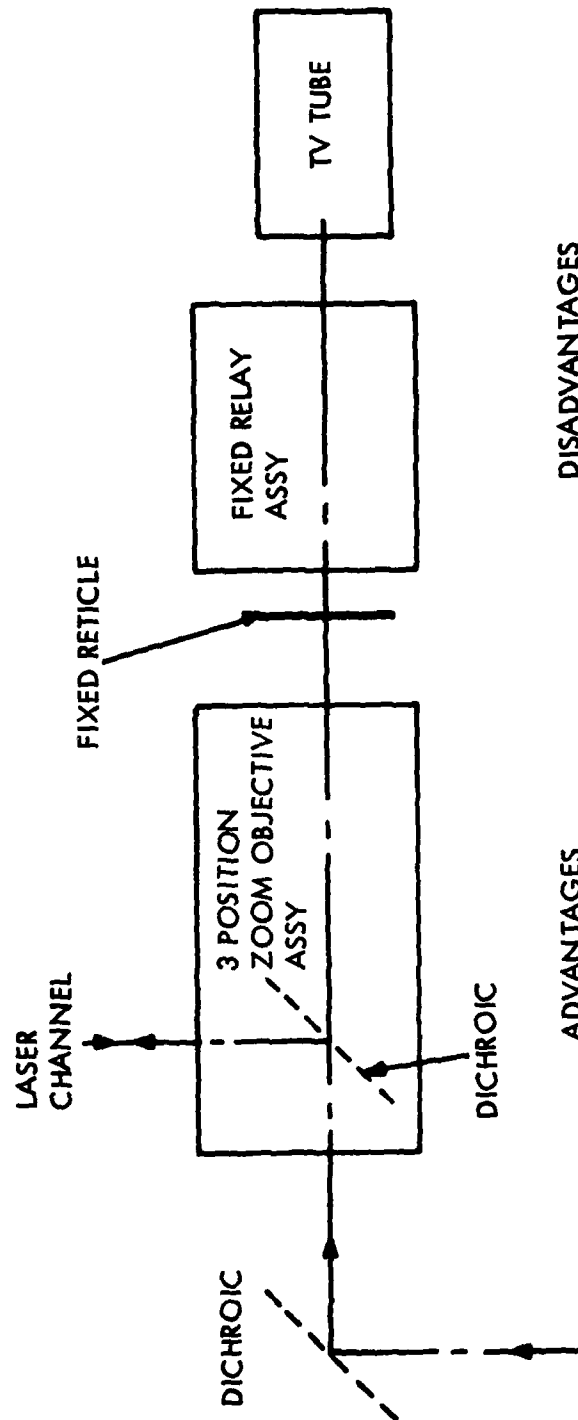

ADVANTAGES

1. LASER CHANNEL SHARES LENS IN OBJECTIVE
2. MINIMUM VOLUME OCCUPIED
3. SIMPLE EXTERNAL CONFIGURATION
4. CONSTANT TRANSMISSION

DISADVANTAGES

1. PERFORMANCE VERY GOOD
2. VERY COMPLEX DESIGN TASK - HIGH COST
3. VIGNETTING WILL OCCUR DUE TO VERY UNFAVORABLE PUPIL LOCATION - PUPIL ALSO MOVES WITH ZOOM
4. POTENTIAL SMALL BORESIGHT PROBLEMS (DUE TO MOTION OF OBJECTIVE)

Figure PY-7. Concept B(3) - 3 Position Zoom Objective and Fixed Relay

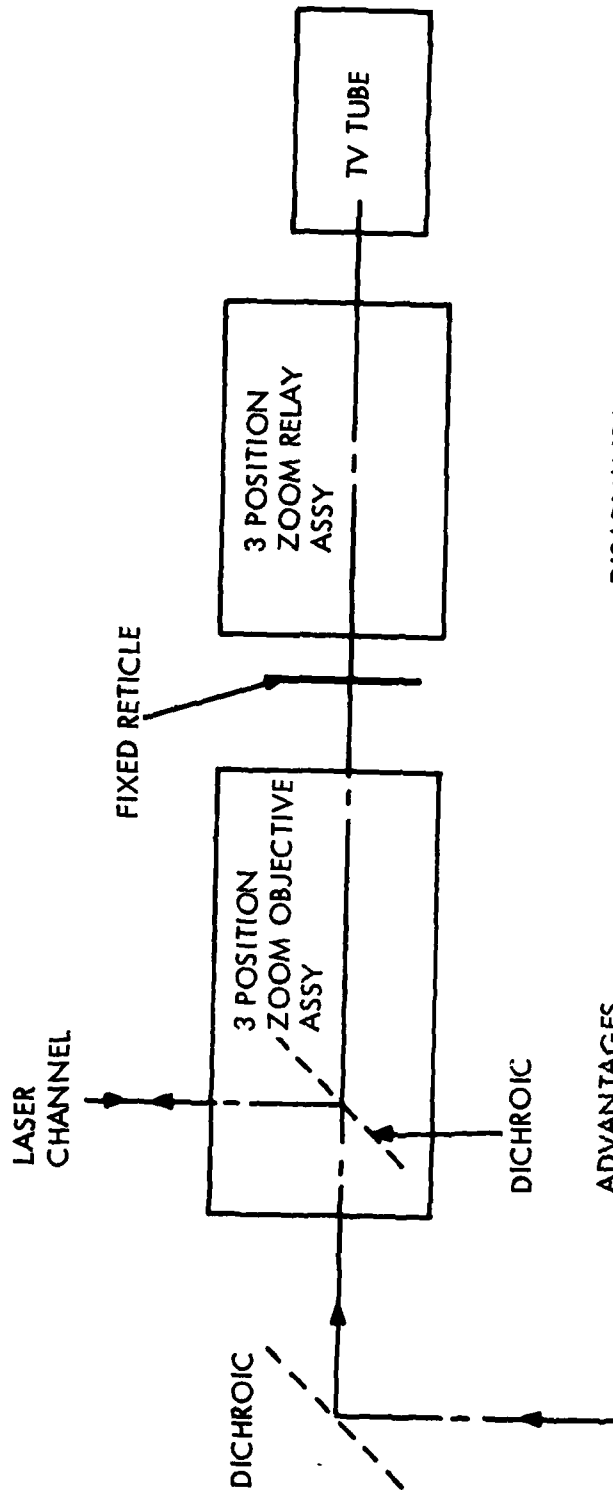

ADVANTAGES

1. LASER CHANNEL SHARES LENS IN OBJECTIVE
2. MINIMUM VOLUME OCCUPIED
3. SIMPLE EXTERNAL CONFIGURATION
4. CONSTANT TRANSMISSION

DISADVANTAGES

1. PERFORMANCE VERY, VERY POOR
2. VERY COMPLEX DESIGN TASK - HIGH COST
3. VIGNETTING WILL OCCUR DUE TO VERY UNFAVORABLE PUPIL LOCATION - PUPIL ALSO MOVES WITH ZOOM
4. POTENTIAL SMALL BORESIGHT PROBLEMS (SUN TO MOTION OF OBJECTIVE)

Figure PY-8. Concept B(4) - 3 Position Zoom Objective and 3-Position Zoom Relay

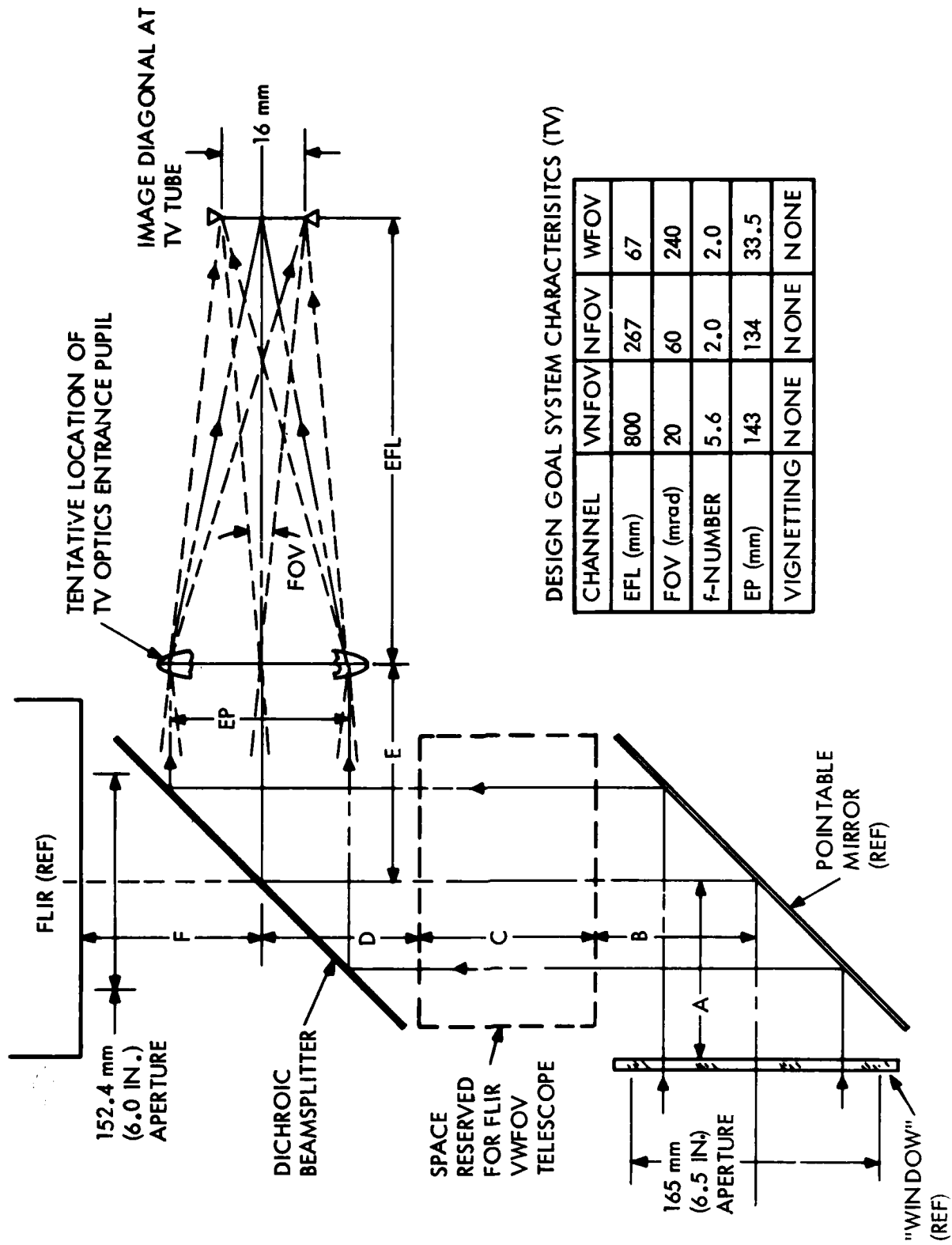

DESIGN GOAL SYSTEM CHARACTERISTICS (TV)

CHANNEL	VNFOV	NFOV	WFOV
EFL (mm)	800	267	67
FOV (mrad)	20	60	240
f-NUMBER	5.6	2.0	2.0
EP (mm)	143	134	33.5
VIGNETTING	NONE	NONE	NONE

Figure PY-9. General Concept of CATIES TV/FLIR Interface with Pointing Mirror

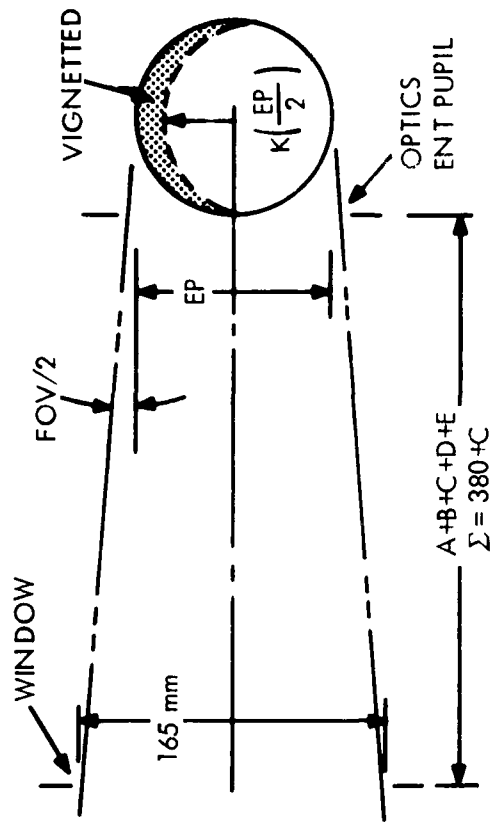

- WITH NO VIGNETTING- (K = 1.0)
MAX $\Sigma = (165-EP)/FOV$
- WITH LIMITED VIGNETTING-(K VARIABLE)
MAX $\Sigma = (165-KEP)/FOV$

CONCLUSION - VIGNETTING BEYOND THE K = 0.707 VALUE PRODUCES LITTLE IMPROVEMENT IN DIM. "C".

DIMENSION	APPROXIMATE VALUE (mm)		
	VNFOV	NFOV	WFOV
A + B =	1100	517	548
D + E =	720	137	168
FOR K = 1.0			
Σ =	3195	1171	589
C =	2815	791	209
FOR K = 0.707			
Σ =	3481	1260	594
C =	3101	880	214
FOR K = 0.667			
Σ =	4675	1633	618
C =	4295	1253	237

Figure PY-10. Consideration of Dimension Change with Vignetting

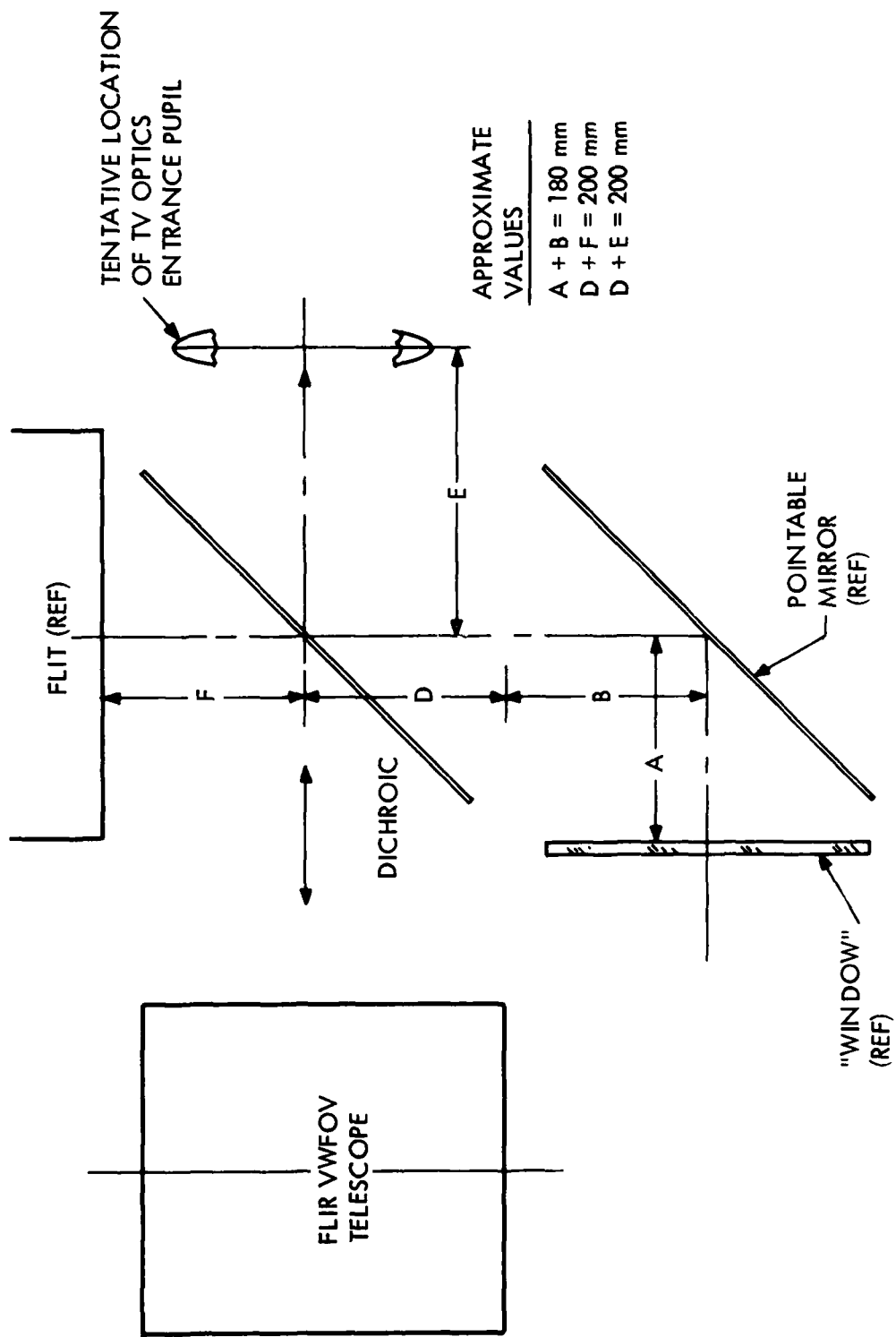

Figure PY-11. Alternate Concept for FLIR/TV Interface

	VNFOV	NFOV	WFOV
<u>EXISTING SPECS</u>			
EFL (mm)	800	267	67
TOTAL FOV (mrad)	20	60	240
F-NO.	5.6	2.0	2.0
<u>PROPOSED SPECS</u>			
EFL (mm)	800	228*	67
TOTAL FOV (mrad)	20	70*	240
F-NO.	5.6	2.6*	2.0

*REVISED VALUES

Figure PY-12. Proposed Specification Revision

	VNFOV	NFOV	WFOV
<u>EXISTING SPECS</u>			
EFL (mm)	800	267	67
TOTAL FOV (mrad)	20	60	240
F-NO.	5.6	2.0	2.0
<u>PROPOSED SPECS</u>			
EFL (mm)	800	267	80*
TOTAL FOV (mrad)	20	60	200*
F-NO.	5.6	2.6*	2.6*

*REVISED VALUES

Figure PY-13. Proposed Specification Revision No. 2

ATTACHMENT 3 TO R&D STATUS REPORT NO. 14
 ASSUMPTIONS FOR THERMAL ANALYSIS ON SPECTRAL SEPARATOR

1. Substrate Material: Germanium and Zinc Selenide
2. Area of the separator to be irradiated:
 - A. Axicon insertion for both the LD/R and illuminator
annulus 6.25 ID; 6.50 OD projected on 45° angle
 - B. Axicon insertion for illuminator and coaxial for LD/R
LD/R: 3.0 in. diameter projected on 45° angle
Illuminator: Annulus 6.25 ID/6.50 OD projected on 45° angle
 - C. Point for illuminator and coaxial for LD/R
LD/R: 3.0 in. diameter projected on 45° angle
Illuminator: 0.375 in. diameter projected on 45° angle
3. Reflectance of Coatings: 98%
4. Reflectance of Germanium: 95% and Zinc Selenide: 95%
5. Power and Wavelength:

	λ (nm)	P(J)	PW (sec)	PRI (sec)
LD/R	1060	0.20	20×10^{-9}	3.3×10^{-2}
Illuminator	722.9	0.0015	20×10^{-9}	1.27×10^{-4}
6. Substrate Dimensions: 9.2 in. diameter by 0.75 in. thick

COMMON APERTURE TECHNIQUES
FOR
IMAGING ELECTRO-OPTICAL SENSORS (CATIES)
R&D STATUS REPORT NO. 15

1. GENERAL

This fifteenth R&D Status Report describes the activities of GE/AESD in the development of the Common Aperture Techniques for Imaging Electro-Optical Sensors (CATIES) Program under Contract F33615-76-C-1135, Item No. 0002, CDRL Sequence 2.

II. PRELIMINARY DESIGN REVIEW

A Preliminary Design Review (PDR) was held in Utica on 30 November and 1 December 1977. Personnel in attendance were from the Air Force, General Electric, and Perkin Elmer. These personnel included the following:

<u>Air Force</u>	<u>General Electric</u>	<u>Perkin Elmer</u>
Lt. Col. W. Wallace	Mr. J. Frichtel	Mr. B. Troidle
Mr. R. Hubbard	Mr. G. Wilson	Mr. P. Yoder
Mr. G. Shroyer	Mr. J. Juliano	Dr. K. Bystricky
Mr. J. Stewart	Mr. D. Pultorak	
Ms. P. Glazer	Mr. M. Kolesa	
Mr. W. Martin	Mr. P. Tracy	
Mr. E. Susedik		
Mr. B. Yasuda		
Mr. G. Mavko		

Preliminary Design Review Booklets were distributed which documented the work performed to date. Several blue line drawings on the system packaging concepts, and displays and controls layouts were discussed.

As a result of this PDR, action items were generated. Associated with these action items, responsibility and due dates were assigned. This Action Item List* is included in this month's report. Responses are presently being generated on schedule from all parties involved.

The CATIES system concept, as presented at the PDR, was acceptable as a baseline. Modifications associated with various Action Items are being evaluated and incorporated where practical. This baseline concept and the appropriate modifications provide a strong foundation for the final detailed design to be presented at the Critical Design Review.

* beginning on next page
(3 pages)

CATIES PROGRAM

DATE: 1 DECEMBER 1977

PAGE: 1 OF 3

ACTION ITEMS

REF: PDR

NO.	SUBJECT	ACTION, RESPONSIBILITY & COMPLETION DATE			
		GE	DATE	AIR FORCE	
1.	18" POD	<ul style="list-style-type: none"> Evaluate Design Compatibility 	CDR	<ul style="list-style-type: none"> Provide Scenario Information for Performance Calculations 	1/15
2.	Target, Atmospheric Assumptions			<ul style="list-style-type: none"> Describe Planned Modifications 	12/9
3.	GFE FLIR				
4.	GFE FLIR	<ul style="list-style-type: none"> Identify Beneficial Minor Mods 			
5.	Deleted				
6.	Spectral Separator	<ul style="list-style-type: none"> Assess Zinc Sel Vs Germanium 	12/9		
7.	Provide ICD's			<ul style="list-style-type: none"> 124867, 124657B, 124659B 	12/16
8.	LR/D Receiver FOV	<ul style="list-style-type: none"> Investigate Requirements 	1/15		
9.	LR/D Receiver OPTICS			<ul style="list-style-type: none"> Provide Information On- 	12/9
10.	LR/D Beam Distribution			<ul style="list-style-type: none"> Determine Shape 	12/9

CATIES PROGRAM

DATE: 1 DECEMBER 1977

PAGE: 2 OF 3

ACTION ITEMS

REF: PDR

NO.	SUBJECT	ACTION, RESPONSIBILITY & COMPLETION DATE		
		GE	DATE	AIR FORCE
11.	Laser Illuminator	<ul style="list-style-type: none"> Investigate Obtaining Pb Vapor Illum. Provide Budgetary Estimate Investigate Potential EMI Problems 	1/15 CDR	
14.	Tower Safety Requirements			<ul style="list-style-type: none"> Provide to GE
15.	LR/D O&M Manual			<ul style="list-style-type: none"> Provide to GE
16.	Control Concepts			<ul style="list-style-type: none"> Review & Comment
17.	Display AIDS & Techniques	<ul style="list-style-type: none"> Provide Budgetary Cost Estimates 	1/15	
18.	LR/D Availability			<ul style="list-style-type: none"> Determine When
19.	Camera Systems (CFE)	<ul style="list-style-type: none"> Provide Budgetary Cost Estimates 	1/15	
20.	FLIR - VWFOV	<ul style="list-style-type: none"> Determine Cost Impact 	12/16	CDR

CATIES PROGRAM

DATE: 1 DECEMBER 1977

PAGE: 3 OF 3

ACTION ITEMS

REF: PDR

NO.	SUBJECT	ACTION, RESPONSIBILITY & COMPLETION DATE		
		GE	DATE	AIR FORCE
21.	Reticle Options			1/15
22.	3RD Gen. Wafer			TBD (12/77)
23.	Spare Parts		CDR	
24.	Update Contract GFE/CFE/SPECS/SOM/ Schedules		1/15	
25.	Displays			1/15
26.	Optics Review		12/12	

COMMON APERTURE TECHNIQUES
FOR
IMAGING ELECTRO-OPTICAL SENSORS (CATIES)
R&D STATUS REPORT NO. 16

I. GENERAL

This sixteenth R&D Status Report describes the activities of GE/AESD in developing a Common Aperture Techniques for Imaging Electro-Optical Sensors (CATIES) Program under Contract F33615-76-C-1135, Item No. 0002, CDRL sequence 2.

II. TECHNICAL

A. SUMMARY

1. During the past month, detailed optical design of the Television path has been underway, with the goal of meeting specification performance objectives. Concepts for illuminator, laser transmitter, laser receiver, and reticle were revised from PDR inputs, and will be finalized when TV path detail design is complete.

2. Detailed mechanical layouts for the scanning mirror, spectral separator, and camera functions are in progress.

Concept layouts for all other opto-mechanical structures have been coordinated with Perkin-Elmer, and will be detailed soon. Preliminary layouts suggest that the CATIES system could be packaged in a 20-inch or smaller diameter pod; details will be presented at the CDR.

3. Electrical interfacing of GFP to control and power distribution console is completed. Functional circuit designs have been identified; detailed circuit designs are in progress. Preliminary electrical component sheets (ECS's) are being generated for completed design.

4. All GE-responsible Action Items from the PDR are complete. Several AF-responsible Action Items are outstanding. These open Action Items have not affected the detailed design activity to date.

B. OPTICS

1. In the detailed optical design, the common objective has been optimized by itself. The original intention of making a perfect intermediate image was found impractical. Although monochromatic MTF's are very good, obtaining MTF's that meet specifications requires additional correction by the relay lenses. First-order optimization of the relays is complete. Work is now directed at balancing aberration control (primarily chromatic) between relays and common objective. Results to date are very encouraging; it appears that all specification parameters will be met.

2. The laser transmitter and receiver problems defined at the PDR have been resolved by the addition of a thin dichroic beam splitter, in the common objective, to reflect the return 1.06μ energy to the receiver. The full aperture of the common objective is used, resulting in a 135 square centimeter collecting area (compared to specification value of 45 square centimeters). Transmission through the beam splitter will be maximized at the expense of 1.06μ reflection, because of the larger collecting area.

3. The lead vapor illuminator will be inserted by using a small mirror bonded to the first element in the common objective. This technique eliminates the need for exotic processing on the spectral separator. Details will be finalized when the TV optical path design is complete.

4. A projected reticle concept has been outlined. This concept used a light-emitting diode projected onto the image, at the intermediate image plane, through the common objective. All of these concepts were described in GE's answer to PDR Action Item 26. Optical schematic diagram, figure 1, shows the latest CATIES optical configuration.

C. MECHANICAL

1. Mechanical design of scanning mirror mount and azimuth/elevation drive are nearly complete. Moment of inertia calculations, which will be used for motor selection and electrical circuit construction, have been made. Camera derotation calculations (including moments-of-inertia) are all complete, and associated drive-circuit design is approaching completion. It was determined that the automatic light control (tape transport) and spectral filter wheel concepts used on other programs are directly adaptable to CATIES. Detail design is being completed, and appropriate requisite circuit modifications identified.

2. Concepts for design and mounting of the common objective, relay turret, laser transmitter, laser illuminator, focus adjust, and boresight reticle have been coordinated with Perkin-Elmer. Final detailed mechanical design is in progress. When these

concepts have been detailed, the optical bench, TIS mounting, and camera mounting will be finalized.

D. ELECTRICAL DESIGN

1. GFE Items. Control interface and primary power wiring interconnection diagrams for TIS and Laser Designator Ranger are completed. Figures 2 and 3 indicate cables to be fabricated at GE and those that should be supplied as GFE. The Glint Remote Control Unit/Interconnect Cable (identified as a GFE Item at the Preliminary Design Review) is no longer needed. Modifications necessary to integrate this assembly proved more extensive than first realized, and its use increases the number of interconnection cables in the system. The circuitry and controls needed to operate both TIS and LDR have been identified and documented.

2. CFE Items. Camera interface functions have been identified. Motors and reference potentiometers for camera derotation, filter wheel, and tape transport (along with associated circuitry) have been selected. Detailed camera circuit design and assignment of function to the camera electronics box or interface electronics unit is incomplete pending Air Force decision to either purchase a camera from GE or to continue with the original plan of modifying two existing CFE Electronics Units (ownership to be retained by GE). The circuitry so far selected can be made compatible with either configuration, but the single electronics unit approach is least complicated and can be implemented in a variety of ways. Work on circuitry for synchronization and for providing other interface

requirements compatible with either approach will proceed as far as is possible.

3. During the next reporting period, detailed schematic diagrams will be gathered, and modified as necessary. Long lead items (e.g., connectors, motors, and selected electrical components) will be identified, to avoid program delays.

E. MEETINGS

Several meetings, summarized in figure 4, were held during this reporting period.

Revised 1-17-78

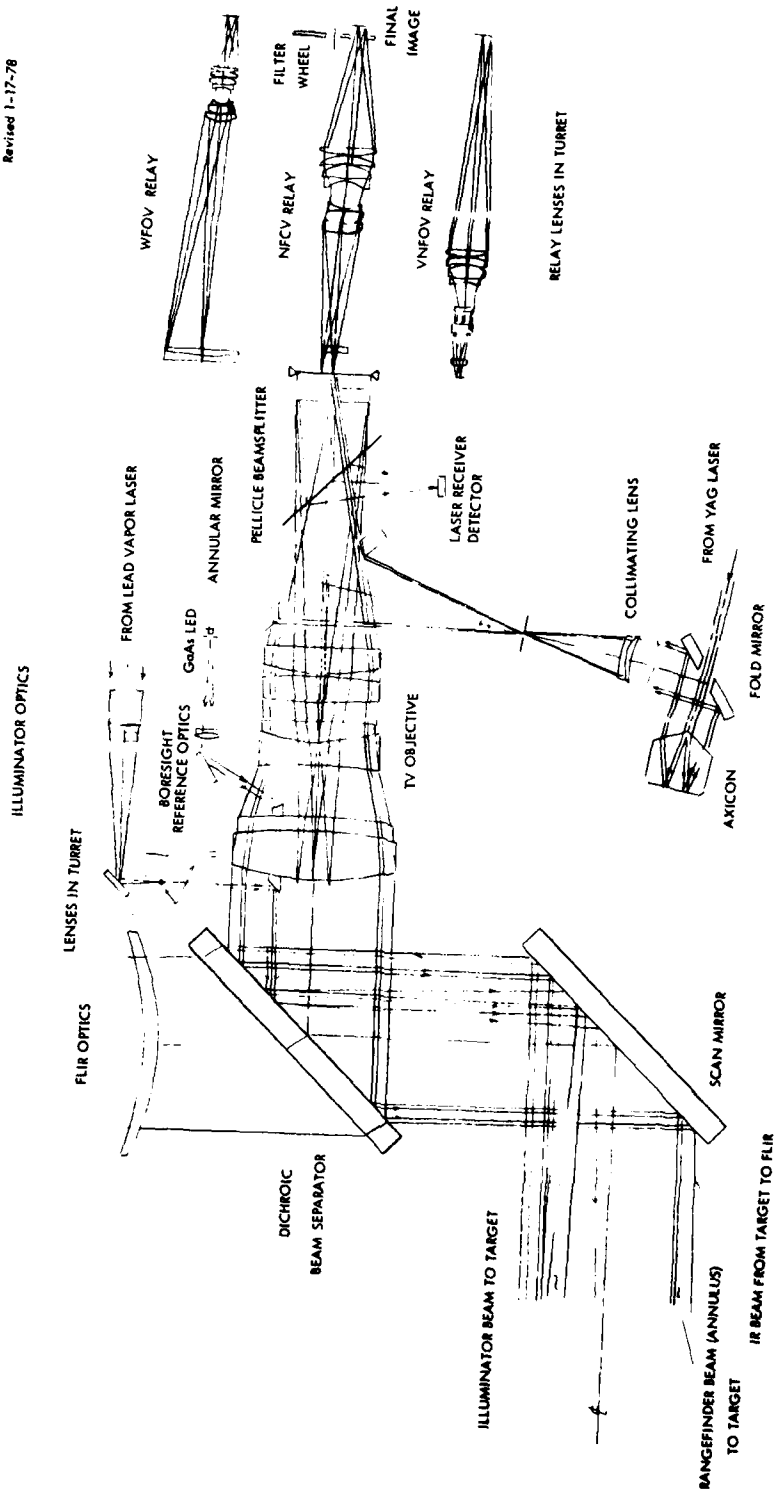

Figure 1. CATIES Optical System, Preliminary Schematic Diagram

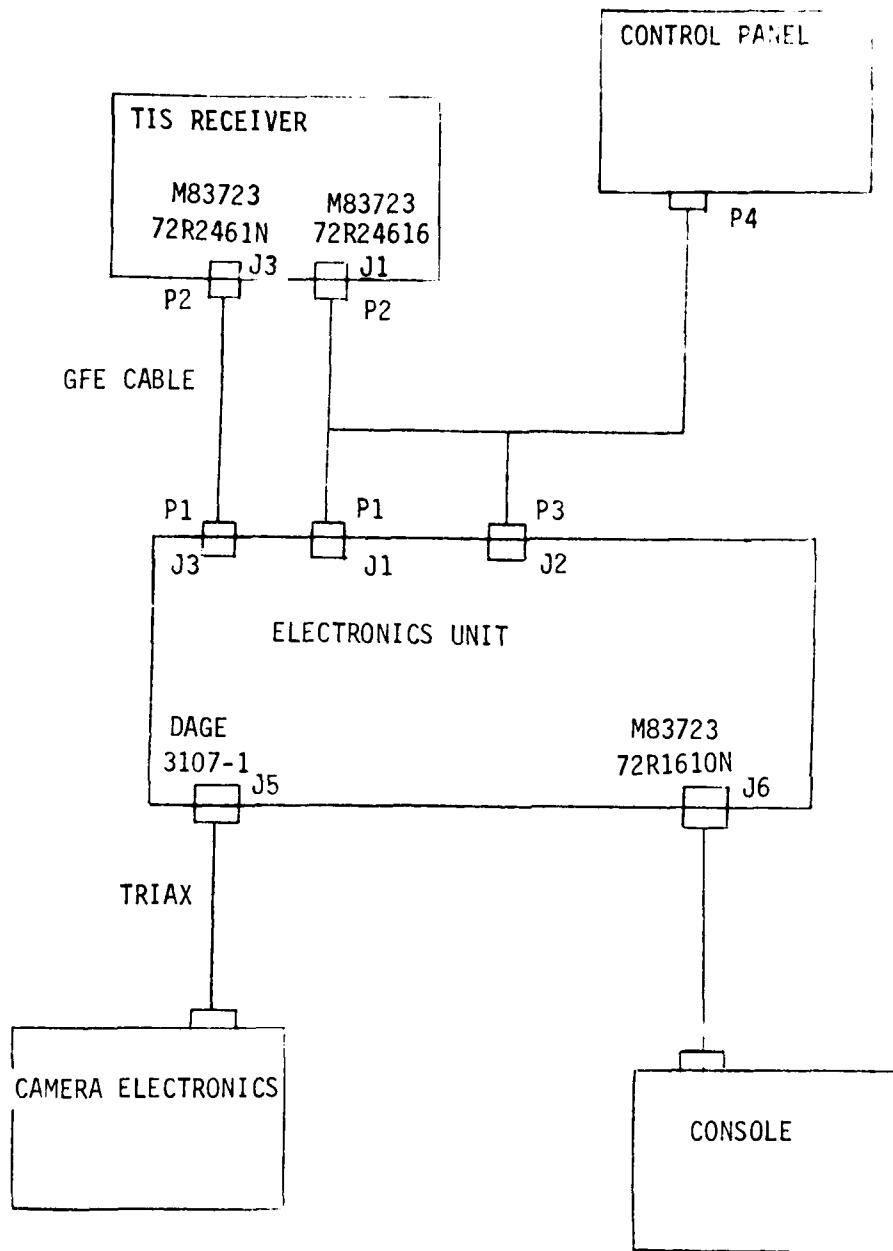

Figure 2. TIS Interconnections

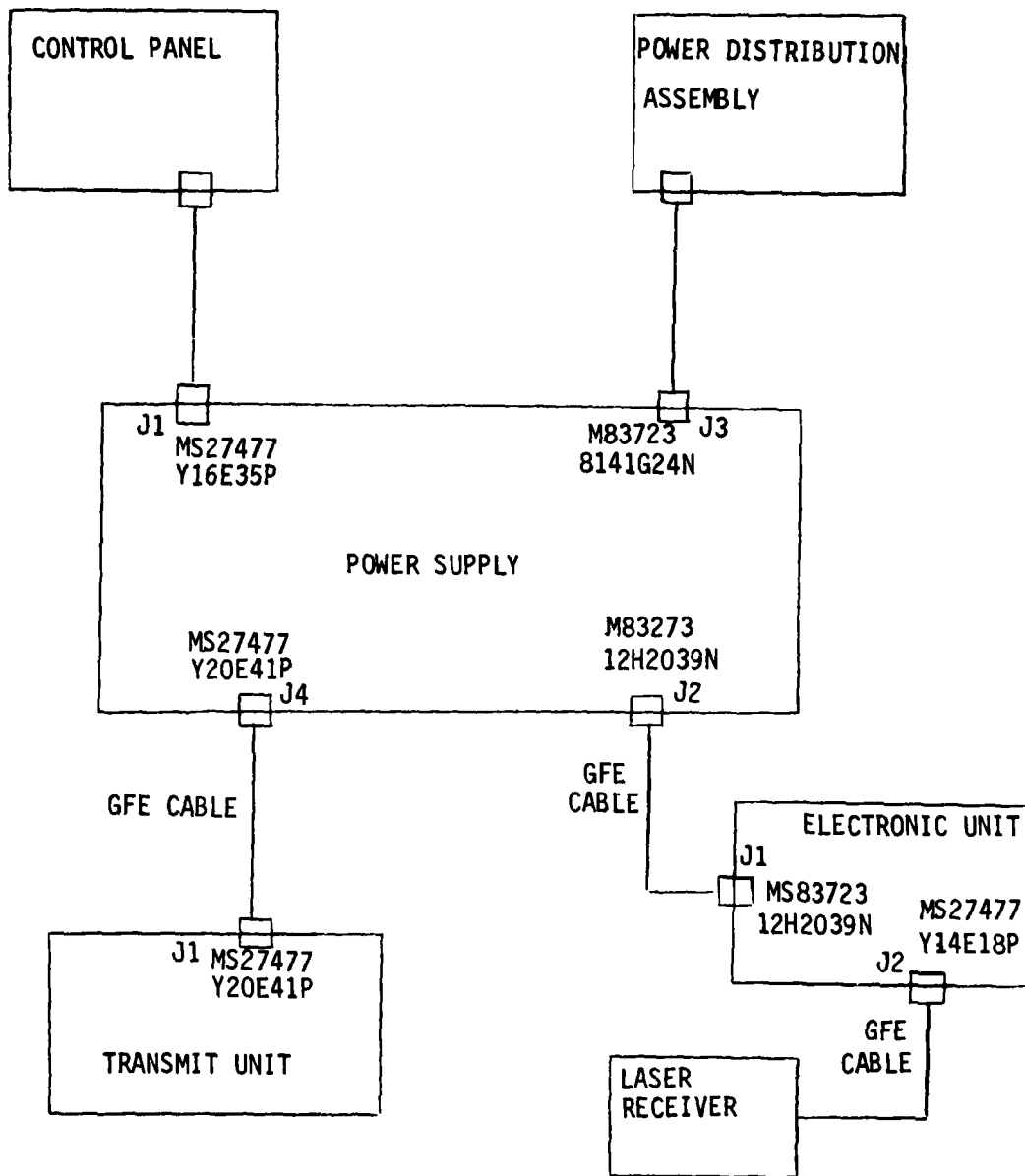

Figure 3. LDR Interconnections

<u>Date and Place</u>	<u>Attendees</u>		<u>Major Purpose</u>
	<u>GE/AESD</u>	<u>Others</u>	
7, 8 December 1977 Perkin-Elmer Norwalk, CT	Mike Kolesa Dan Pultorak	Ben Troidle, PE Paul Yoder, PE Dr. Bystricky, PE	Resolve Questions Raised at PDR
18, 19 January 1978 Perkin-Elmer Norwalk, CT	Mike Kolesa	Ben Troidle, PE Paul Yoder, PE Dr. Bystricky, PE	Mechanical Coordination
24 January 1978 NVL Ft. Belvoir, VA	Jim Juliano	Jim Stewart, AFAL Fred Carlson Bill Dateno Dr. Herb Pollehn	3rd Generation Intensifier for CATIES ATV
25 thru 27 January 1978 WPAFB Dayton, OH	Jim Juliano	Jim Stewart Bill Martin	Review Action Items

Figure 4. Meeting Summary for Report Period

COMMON APERTURE TECHNIQUES
FOR
IMAGING ELECTRO-OPTICAL SENSORS (CATIES)
R&D STATUS REPORT NO. 17

I. GENERAL

This seventeenth R&D Status Report describes the activities of GE/AESD in developing a Common Aperture Techniques for Imaging Electro-Optical Sensors (CATIES) Program under Contract F33615-76-C-1135, Item No. 0002, CDRL sequence 2.

II. TECHNICAL

A. SUMMARY

1. During the past month, detailed optical design of the television path was completed, except for the very narrow field-of-view relay lens. Using the initial relay concept, longitudinal and lateral color aberrations could not be controlled. An alternate relay concept has been developed; the results look encouraging. Laser designator/ranger insertion paths were reconfigured to eliminate the pellicle.

2. The scanning mirror, spectral separator, camera derotation and focus, and optical filter module/automatic light control designs were completed. Details of the relay turret drive and relay lens cell mounting are being updated as a result of a mechanical coordination meeting with Perkin-Elmer. Because of the new insertion path concepts, optical layouts for the system must be redone. Detailed mechanical drawings for the completed subassemblies are in progress.

3. All circuit designs, including the display aids and techniques circuitry, are complete to functional block diagram level. This circuitry, at functional level, has been worked-out for either the CFE electronics boxes or the AF procured electronics box. An updated system functional block diagram has been prepared. Long lead electrical parts lists are now being generated. Final circuit designs will be completed shortly.

4. Critical Design Review is postponed until April 5, 6, 7, because of optical design problems. During this one month, detailed fabrication drawing — initially scheduled as a front end phase 3 activity — will be generated; long lead parts lists are being developed for prephase 3 ordering (with AF concurrence). These activities will allow the scheduled delivery to be "on-time".

5. Several open AF action items (CFE vs AF procured hardware) are beginning to require double design activity, primarily for camera and display circuitry. Early direction in these two areas is needed to maintain the hardware delivery schedule.

B. OPTICS

1. Design activity associated with the insertion of a dichroic beam splitter of finite thickness in the common objective to split-off energy for the YAG laser receiver was not productive. Optical performance requirements resulted in the need for a pellicle. Because of structural problems with a pellicle, a new configuration for the optical system was developed (see figure 1). This concept includes existing optical designs, but rearranges the LD/R and TV paths as shown, and also eliminates two annular mirrors that were troublesome to fabricate and align.

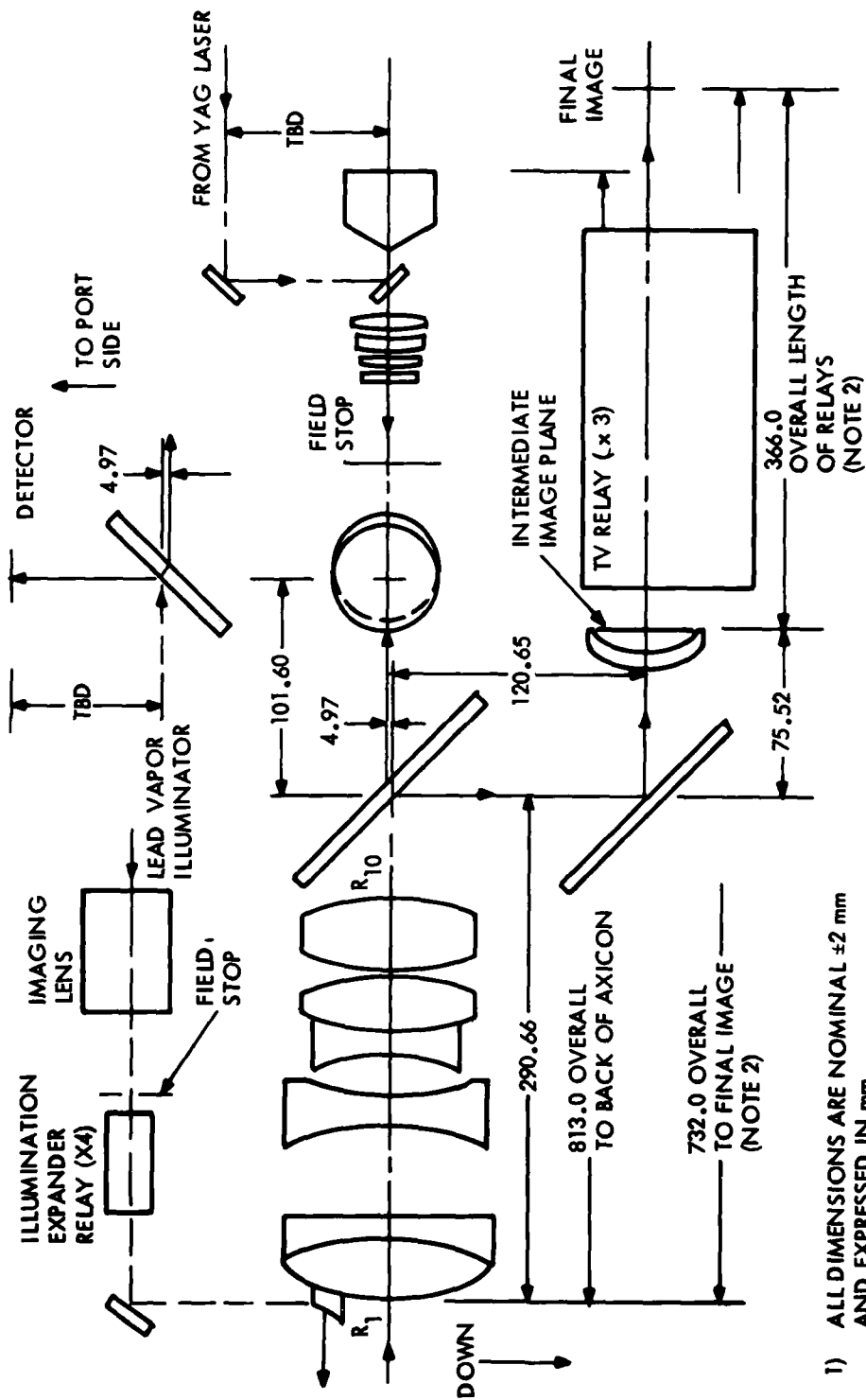

- 1) ALL DIMENSIONS ARE NOMINAL ± 2 mm AND EXPRESSED IN mm.
- 2) IMAGE SHIFT DUE TO FILTERS AND TUBE WINDOW NOT INCLUDED.

FIGURE 1. RECONFIGURED OPTICS LAYOUT

2. Detailed design for wide and narrow fields-of-view (total TV optical path) has been completed. Optical performance data for the CDR are being prepared. In the two completed paths, it appears that all specification parameters will be met. At a meeting at Perkin-Elmer (refer to paragraph E), it was determined that vignetting the WFOV aperture slightly would improve the off-axis MTF (limited by astigmatism) while still meeting the relative illumination requirements of the specification. The WFOV relay contains eight elements, the NFOV relay ten elements.

3. The very narrow field-of-view (VNFOV) suffers from longitudinal and lateral chromatic aberrations to the extent that specification performance can only be met monochromatically. A more promising alternate concept for this relay lens has already resulted in monochromatic MTF's that meet specification values; Perkin-Elmer is now working at broadening the spectral band while maintaining specified values. March 10th is the anticipated date for completion of this relay.

4. The LD/R transmitter optical assembly design, including the axicon, is complete. Collimating optics now consists of a four-element group instead of the two-element group shown at the PDR. Reconfiguration resulted in the elimination of two annular mirrors in the optical system — one near the axicon, and one large one in the common objective (refer to PDR booklet). The LD/R receiver optical design is delayed because of the TV VNFOV relay problem. It is anticipated that, at worst, a single correction element near the detector will be required to ensure that collected energy can focus to a spot smaller than detector size.

5. Optical design for the lead vapor illuminator insertion is complete, and comprises a three-element imaging lens followed by four air-spaced triplet relays. The four relays operate in pairs, to match either the vertical or horizontal field of view of the television path, in both NFOV and VNFOV. This approach permits versatility during tower testing.

6. Boresight reference optical design is complete. This assembly will be hard-mounted to the optical bench to provide a repeatable system boresight check. This reference will contain an adjustable-intensity incandescent source projected onto the pointing mirror to facilitate boresighting (to optical axis/YAG laser) of the TIS, ATV, and passive TV. The boresight reference assembly is shown in figure 2.

C. MECHANICAL

1. Mechanical design of scanning mirror assembly and spectral separator mounting are complete. Detailed fabrication drawings are now in progress.

2. Camera derotation and focus assembly mechanical designs, as well as OFM/ALC designs, are complete. Piece-part drawings will be generated during the next month.

3. Relay turret design has been coordinated with Perkin-Elmer; modifications associated with relay lens cell mounting interface are being incorporated. Because of the reconfigured optical system, mounting of the relay turret to the optical bench must be changed; this redesign is now in progress.

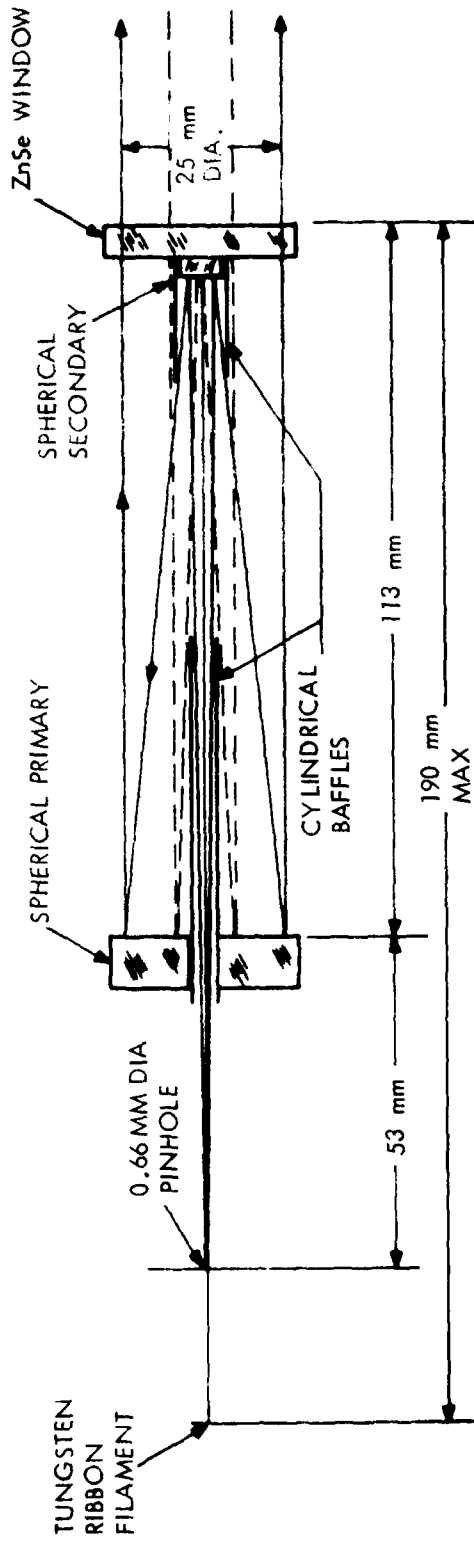

OPTICAL CHARACTERISTICS

EFL = 937 mm
 CA = 25 mm
 F-NO. = 37.5
 FIELD = + 0.39 MRAD
 (INCL. DIFFRACTION
 = 0.22 mm)
 LINEAR OBSCURATION = 35%

FIGURE 2. BORESIGHT REFERENCE, OPTICAL SCHEMATIC

4. Display mount and control console mechanical designs are in progress, and will be completed by March 3rd. Control panel layouts are complete. Component (e.g., potentiometers, switches) mounting will be finalized for fabrication after receipt of AF concurrence on the control layouts. This concurrence is expected by March 9th.

D. ELECTRICAL

1. System. Before this report period, circuit design and drawings were developed to the extent needed to establish viable synchronization techniques and workable approaches for either two separate CFE TV electronic units or a single unit with incorporated display circuitry. As no final decision favoring one of these approaches has been made, a parallel design effort has been conducted to accommodate all required circuits, thereby allowing system design to proceed.

2. The two-camera electronics unit approach requires a more complex synchronization technique — one which is not compatible with the existing sync generator assembly (although compatible with an updated version of this PWA). This modification, as well as the detailing of interface drawings to reflect packaging of display circuitry in the interface electronics unit, has now been completed in enough detail to identify major system cable paths, and number and type of necessary connectors.

3. Both control panels have been re-laid out to reflect both AF recommendations made at PDR and changes in the CATIES system concept resulting from optical and mechanical design maturity. Current efforts are directed to defining system connector requirements and standardizing functional terms and nomenclature.

4. During the next report period, these updating tasks are expected to continue, and a detailed review of all CFE camera electronic circuitry is to be conducted. The purpose of this review is to identify and document all necessary modifications — including pin assignments, component changes, addition of connectors to the housing, and rewiring of internal harnesses as needed.

5. Lead Vapor (PbV) Illuminator. Until now, design of the electrical interface has proceeded on the basis of previous experience with the existing hardware, and the assumption that AESD would be involved in specifying equipment interfaces. As such, some flexibility (electrical and mechanical) is possible both before and during fabrication of the illuminator. When specific design parameters of this hardware are established (including number of modules, commercial high-voltage power supply model number, connector types and power requirements, etc.) AESD must be notified of any changes made by the Air Force. This information will permit smooth integration of the illuminator into the CATIES System.

6. Long lead-time item electrical parts lists are being compiled for all completed circuit designs. These parts will be identified to the AF, with a request for pre CDR procurement.

E. MEETINGS

Two meetings, summarized in figure 3, were held during this reporting period.

<u>DATE AND PLACE</u>	<u>ATTENDEES</u>		<u>MAIN PURPOSE</u>
	<u>GE/AESD</u>	<u>OTHERS</u>	
1 February 1978 GE, Utica, NY	Jim Juliano Dan Pultorak Mike Kolesa	Ben Troidle, PE Paul Yoder, PE	General Program Review
21, 22 February 1978 PE, Norwalk, CT	Jim Juliano Dan Pultorak Mike Kolesa	Ben Troidle Paul Yoder Dr. Bystricky Dr. Casals Al Bodnar Ralph Lacroy	Mechanical and Optical Review of Phase 2 Design Activity

Figure 3. Meeting Summary for Report Period

COMMON APERTURE TECHNIQUES
FOR
IMAGING ELECTRO-OPTICAL SENSORS (CATIES)
R&D STATUS REPORT NO. 18

I. GENERAL

This eighteenth R&D Status Report describes the activities of GE/AESD in developing a Common Aperture Techniques for Imaging Electro-Optical Sensors (CATIES) Program under Contract F33615-76-C-1135, Item No. 0002, CDRI. sequence 2.

II. TECHNICAL

A. SUMMARY

1. During the past month, detailed optical design of the CATIES Optical Package was completed. Element drawings, performance estimates, and a design data sheet have been delivered to AESD. The VNFOV relay must still be used with a restricted bandwidth, to meet MTF requirements.
2. Phase 3 cost estimates based on final design information are being accumulated.
3. All mechanical and electrical design tasks have been completed.
4. Approval for long lead parts ordering has been received. Material Request Sheets are being generated, from which parts will be procured.
5. All PDR open action items were resolved during the month.

6. Several meetings were held to discuss the GFE lead vapor (PbV) laser.

B. OPTICS

1. The CATIES optical design was completed during the month. Element drawings, preliminary housing drawings, and performance estimates were received. This information is now in review.
2. The VNFOV relay has secondary color problems that restrict its operation to nearly monochromatic spectra. For the night camera and VNFOV, no system impact is expected, because this configuration is primarily an active mode (i.e., used with the lead vapor laser). For the day camera and VNFOV, however, a Notch filter will have to be used. (See figure 1.)
3. Phase 3 cost estimates for the optics are now in progress. Final details will be presented at the Critical Design Review.

C. MECHANICAL

1. All mechanical design tasks are complete except those for the lead vapor laser relay-turret. This design requires only a small effort, but depends on a laser housing that is undefined (refer to Appendix A).
2. Detailed fabrication drawings are in progress, and are scheduled for completion by mid May.
3. The control console is in the ordering cycle at AESD, and should be in-house by the end of May.

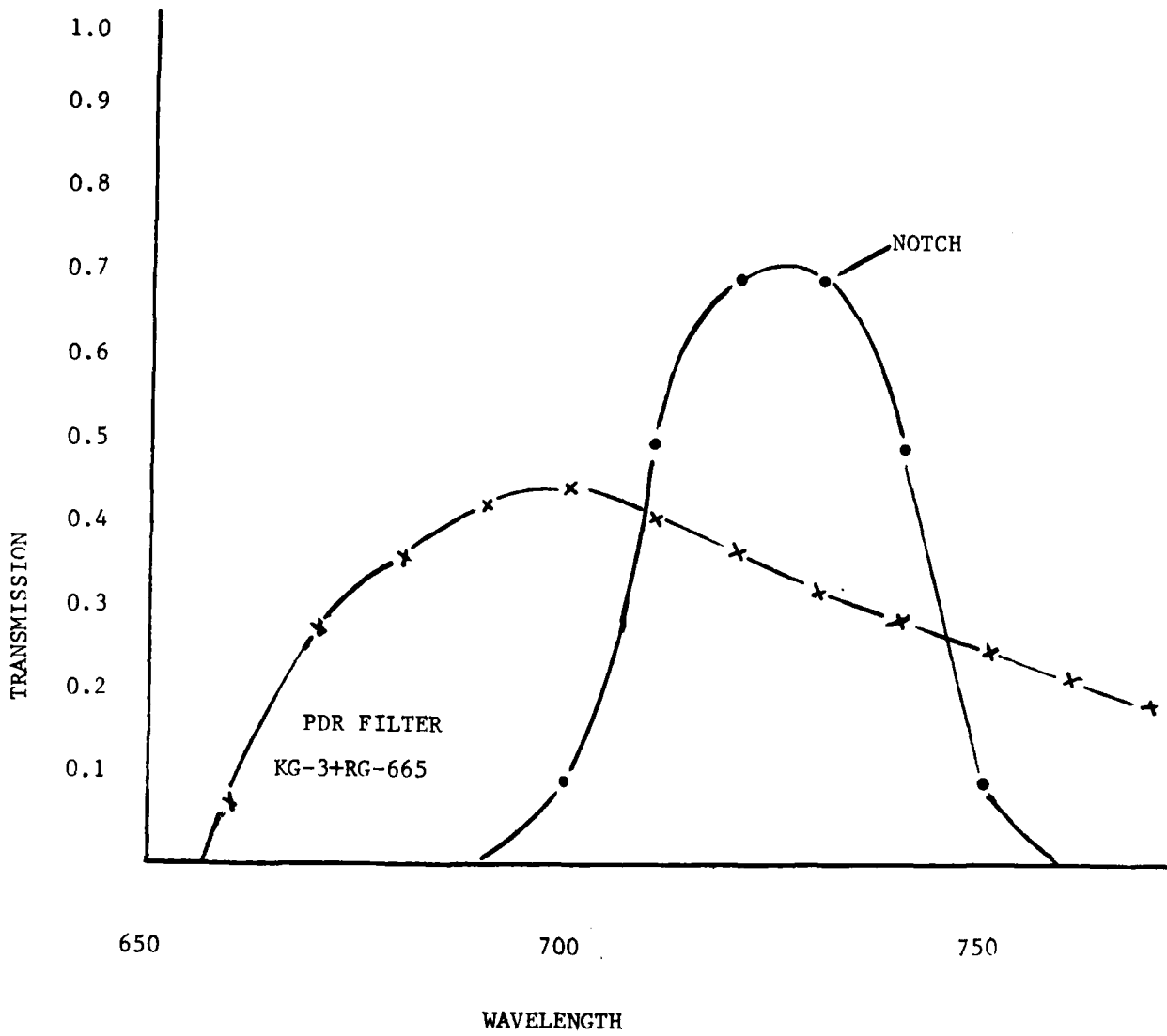

Figure 1. Notch Filter Characteristics

D. ELECTRICAL

1. All circuit designs, including those for the video mix/split screen, are complete.
2. All cables have been laid out on a pin-for-pin basis. Cable lengths are currently being determined.
3. Final electronics-box modifications are nearly complete. This work entails marking-up electrical schematic diagrams and wiring harness drawings for compatibility with the video mix/split screen synchronization circuitry.
4. Electrical interface of the lead vapor laser is not complete. This interface cannot be finalized until the laser circuit designs are reviewed by AESD (refer to Appendix A).
5. Material Request Forms are being generated for ordering motor/tachometer assemblies, connectors, and electrical components, as defined in the AESD letter requesting pre-CDR long lead parts ordering.

E. MEETINGS

Several meetings were held during this reporting period. (See figure 2 for summary.) The meeting at Space Science Laboratories, GE, is summarized in Appendix A.

F. MISCELLANEOUS

During this reporting period, the third-generation intensifier was tested. Photocathode and gain measurements, as well as gating tests, were performed. Intensifier tests were impressive, and

<u>Date</u> <u>And Place</u>	<u>Attendees</u>		<u>Main</u> <u>Purpose</u>
	<u>GE/AESD</u>	<u>Others</u>	
9 March 1978 WPAFB, Dayton OH	Jim Juliano Paul Tracy	Jim Stewart Dr. Wolfgang Shukel Bob Gedling George Mauko Brian Yasuda	Program Technical Review Resolve Open Action Items Lead Laser Procurement
15 March 1978 GE/SSL, Philadelphia, PA	Dan Pultorak Mike Kolesa	Dr. B.G. Bricks	Lead Laser for CATIES
29 March 1978 GE, Utica NY	Jim Juliano Pete Wing Paul Tracy	Ben Troidle, PE Gus Garbarino, PE	Optics Review

Figure 2. Meeting Summary for Report Period

suggest that the intensifier would be useful in the CATIES
brassboard; but, as was anticipated, the photocathode-to-
microchannel plate potential in both passive and active modes
will have to be greater than the requirements for a second
generation tube. Test results will be discussed at the CDR.

APPENDIX A

CATIES LEAD VAPOR (PbV) ILLUMINATOR

MINIMUM SIZE AND CONFIGURATION

(Summary of Meeting at Space Science
Laboratories, GE)

APPENDIX A
CATIES Lead Vapor (PbV) Illuminator
Minimum Size and Configuration

The lead vapor laser demonstrated approximately one year ago was housed in a 15-inch X 15-inch X 60-inch box, and is basically the same configuration used for SSL's copper vapor laser.

The illuminator head contains the lasing cavity, RFI filtering, the thyatron, pulse discharge circuitry, and several small blower assemblies for cooling. Discussions at SSL were directed at carrying the development of the laser prototype one step closer to an airborne configuration.

It appears that the height and width could be reduced by about five inches over most of the 60-inch length with minimal effort. The thyatron and RFI circuits would have to be repackaged in a small volume alongside the laser cavity, causing a protrusion (about 10-inches high X 6-inches wide X 20-inches long). With additional funding, they feel that some of the mounting flanges could be reduced further, and the housing re-configured into two attached cylinders (one 60-inches long, the other approximately 15-inches long) to make it even smaller.

There are a number of large size accessories external to the head assembly that will have to be incorporated into the CATIES system. A control console (containing a commercial high-voltage pulse generator, primary power activating circuits, pressure/temperature monitoring and vacuum pump control functions) is needed. SSL is currently designing a single purpose pulse generator that can free run and be externally synchronized. Approximately 12-inches of panel space is needed for the other functions.

Water cooling will be required for the windows at each end of the laser cavity. (A higher temperature sealing technique would be needed to eliminate this requirement.) This requirement means that a water hook-up will be needed at each CATIES test site, or that a closed-cycle water circulator must be purchased. SSL is now using a commercial chilling unit (about 15-inches X 20-inches X 25-inches) to cool the windows and a thyratron. Because the thyratron quoted is air-cooled, a much smaller cooling unit could be procured.

Currently, the helium is supplied by a laboratory-type tank, which could be replaced by a small thermos container or dewar flask. A vacuum pump (about 15-inches wide X 20-inches long X 12-inches high) is needed to maintain pressure values for optimum operation. Finally, a high-voltage DC power supply must also be incorporated into the CATIES system. The 5 KW unit selected is Model 807.5-670 manufactured by Hippotronics Company, Brewster, New York (Federal Supply Code 25284). The unit is commercially available, small (17½-inches high X 19-inches wide X 17-inches deep - rack mount), and comes with a 20-inch shielded cable for the high-voltage output.

Some additional information (i.e., operating characteristics) was obtained about each of the equipments, during the meeting. Jerry Bricks was given a brief rundown on the CATIES system to familiarize him with its components and organization. The next step is to determine the degree of hardware maturity the Air Force feels CATIES needs, and in what areas GE, Utica will be required to integrate the lead vapor illuminator into the CATIES system

COMMON APERTURE TECHNIQUES
FOR
IMAGING ELECTRO-OPTICAL SENSORS (CATIES)
R&D STATUS REPORT NO. 19

I. GENERAL

This nineteenth R&D Status Report describes the activities of GE/AESD in developing a Common Aperture Techniques for Imaging Electro-Optical Sensors (CATIES) Program under Contract F33615-76-C-1135, Item No. 0002, CDRL sequence 2.

II. TECHNICAL

A. SUMMARY

1. The Critical Design Review was held at WPAFB on 5 and 6 April 1978. A CDR action list (figure 1) was generated. Since the CDR, all GE required action items have been supplied.

<u>Action Item</u>	<u>Responsibility</u>	<u>Date (1978)</u>
1. NVL Questions and Relay AF	GE	7 April
2. Length of Interconnection Cables in Tower (Console to Sensors)	AF	14 April
3. Letter on Cost/Schedule to AF as Result of Optics (Telecopied to AF on 14 April)	GE	14 April
4. Lead Vapor Uniformity	GE	21 April
5. Run HI TRAN program on Lead Vapor Laser	GE	28 April
6. Classified/ Corrected CDR Book (Addendum)	GE	11 May
7. Investigate Digital Readout on AZ/ EL Position	GE	11 May
8. Mechanical/ Electrical Data on Lead Vapor Laser	AF	11 May

Figure 1. Critical Design Review (CDR) Action Item List

4. Approximately 90-percent of material needed to fabricate hardware other than the optical assembly is on order. A light-emitting diode digital-display for the Azimuth and Elevation readouts has been designed and incorporated into the system. Drafting detailing continues, and is complete enough to allow starting the assembly of some circuit boards and interconnecting cables during the next report period.

B. OPTICS

The optical vendor has delivered optical element manufacturing drawings, a tolerance analysis for TV optics, and a computer printout of subsystem designs. Figures 3 through 5 contain additional data relating to WFOV uniformity, TV optics distortion, and laser performance, in summary form. AESD has been reviewing all provided technical data and cost quotes, and has been communicating with PE for necessary clarifications and supplemental data. AESD is also soliciting outside vendor quotes for comparison with the PE Phase 3 fabrication quote and to evaluate other alternatives now under consideration (e.g., deletion of YAG laser optical path and deletion of two lead vapor illuminator optical paths). Right now, it appears that quotes from the following companies will arrive during the next report period:

<u>Company</u>	<u>Location</u>	<u>Portion(s) of Optics Package Quoted</u>
Alpha Optical Co.	Ocean Springs, MS	Glass Fabrication/ Coatings, Total System
OSTI	Bedford, MA	Total System
Space Optics	Chelmsford, MA	Total System
Optical Instrument Co.	Buena Park, CA	Glass Fabrication/ Coatings
Herron Optical Co.	Palo Alto, CA	Coatings
Frank Mitchell Associates	Pasadena, CA	Mechanical Consultation
Don Kienholz	Hillsboro, NH	Optical Consultation

C. MECHANICAL

Detailed drawings for fabricating the control console and the main sensor support structure are being drafted. The interface electronics unit is the last remaining large subassembly to be completed during the next report period. Printed circuit boards for the control console and interface electronics unit are currently being fabricated. The two sync generator boards are available; components will be mounted as soon as console circuits are laid out.

D. ELECTRICAL

About 90-percent of the required materials have been ordered by now. All technical data for mounting and installation of components in the console have been supplied to the vendors. As recommended at the CDR, an evaluation of a digital light-emitting diode (LED) display for azimuth and elevation readouts was conducted (see CDR action item 7). As costs for either approach were about the same,

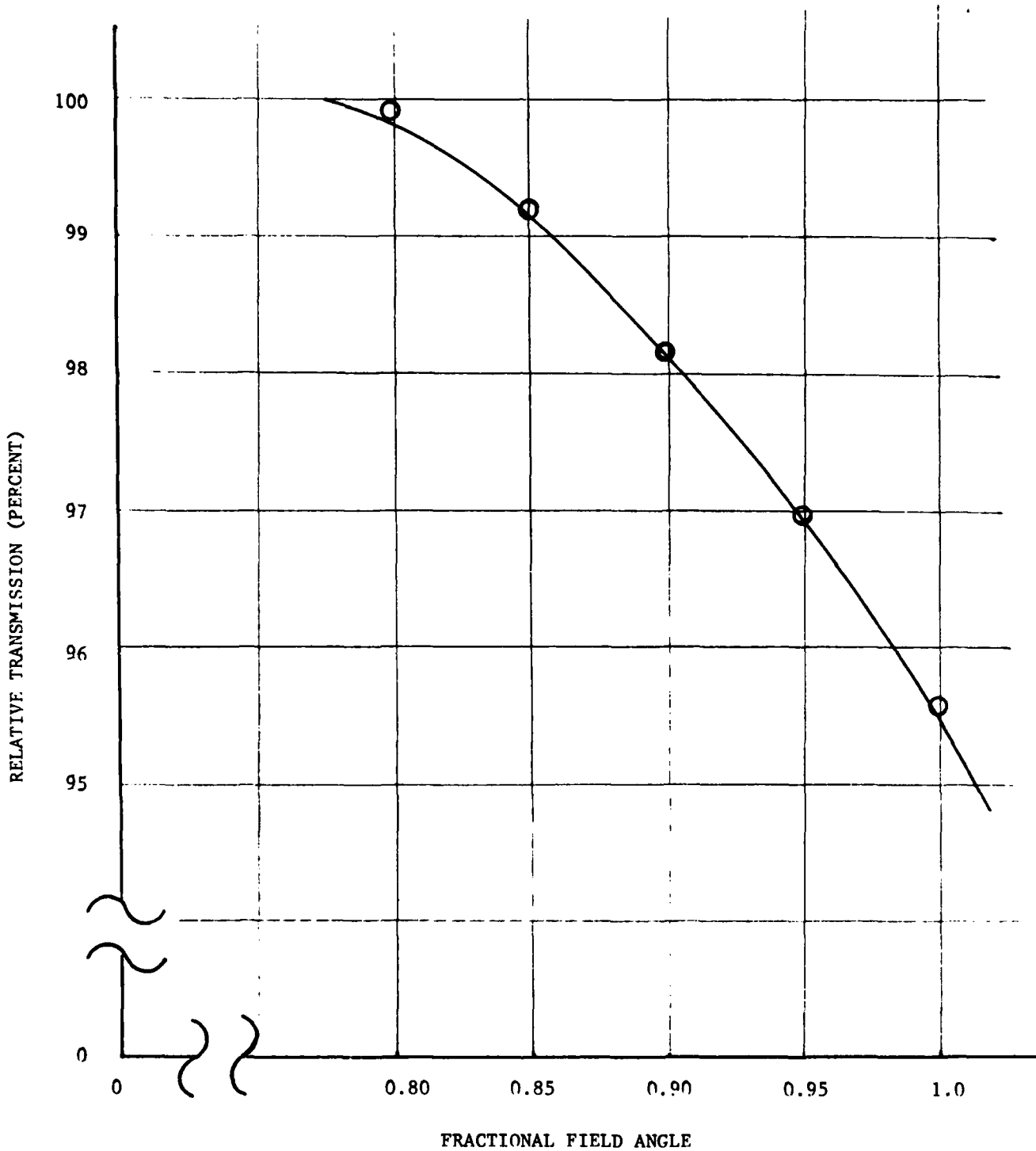

Figure 3, Relative Transmission Fall-Off of WFOV Channel, Due to Vignetting

<u>Channel</u>	<u>Field Location</u>	<u>Distortion</u>
NFOV	0.7 Zone	0.68 μm (0.01 %)
	Full Field	1.87 μm (0.02 %)
WFOV	0.7 Zone	20.8 μm (0.26 %)
	Full Field	34.0 μm (0.43 %)

Figure 4. TV Optics Distortion Data

<u>Channel</u>	<u>Output Beam Divergence (mrad)</u>	<u>Maximum Angular Aberration In Output Beam (mrad)</u>	<u>Beam Diameter (mm)</u>
LRF XMTR	0.8	± 0.027 on axis ± 0.034 full field T] avg ± 0.082 full field S] ±0.06	158 od annulus
ILLUMINATOR MODE 1	48	± 0.154 on axis ± 0.311 full field T] avg ± 0.116 full field S] ±0.21	3.31
ILLUMINATOR MODE 2	36	± 0.079 on axis ± 0.228 full field T] avg ± 0.089 full field S] ±0.16	4.41
ILLUMINATOR MODE 3	16	± 0.035 on axis ± 0.149 full field T] avg ± 0.042 full field S] ±0.10	9.92
ILLUMINATOR MODE 4	12	± 0.031 on axis ± 0.132 full field T] avg ± 0.034 full field S] ±0.08	13.2

Figure 5. Auxiliary Channel (Laser) Performance Data

circuits compatible with each of four one-inch-high characters were designed. A smaller display consisting of three 0.6-inch LED's will also be mounted on the control panel, to provide target range information (in kilometers) when the active TV camera is operating.

E. MEETINGS

During this reporting period, the Critical Design Review was held. The attendees are listed in figure 6.

F. MISCELLANEOUS

1. A potential problem with use of a tungsten-ribbon filament in the optical boresight spot assembly (as proposed by PE) has been uncovered; two possible solutions are currently being evaluated in the laboratory. The ribbon filament was originally selected because it provided a large radiance source and high energy density detectable by both the TV and TIS. However, the filament enclosure (i.e., bulb) does not transmit the energy beyond four microns (six microns for sapphire), which does not meet TIS requirements. The energy in the eight-micron to twelve-micron band would be derived from the re-radiation characteristic of the glass enclosure. Radiated energy would be considerably less than anticipated and, since the tungsten ribbon needs so much current (5 to 30 amperes), considerable heat would be generated, thereby greatly elevating the temperature at the pinhole aperture. Rather than cool the aperture plate, to maintain a resolvable temperature difference for the TIS, alternate light sources are being considered.

Air Force

Col. Wallace
Gale Urban
Gerry Schroyer
James Stewart
William Martin
Capt. W.D. Strautman
Paul McManamon
Barry Hardin
Capt. R.S. Shinkle
A. Grandjean
Capt. H.E. Hagemer
W.K. Schuebel
E. Susedik

General Electric

Paul Tracy
Manuel Hunter
Carl Moliski
James Juliano
Daniel Pultorak
Michael Kolesa
Harry Dolsen

Perkin-Elmer

Benno Troidle
Paul Yoder

Figure 6. CDR Attendees

2. A relatively low power coil-filament source would generate much less heat, and still be usable to the TV cameras. A glass window (ground on the input side for diffusion, and coated with tin oxide on the output side for heat absorption) could then be inserted for thermal isolation of aperture plate and source. Heat energy below six microns, the major contributor to aperture plate temperature rise, would be absorbed by this transparent coating. Because the coated outside surface rises approximately 20-degrees Celsius above room temperature (as measured with a thermocouple), this surface becomes a new source of infrared energy for the TIS.

3. It has also been found that a laser diode generates enough heat to elevate the temperature of its projection lens about 20-degrees Celsius above ambient, with only 0.5 ampere of current. Response time is fast (about 15 seconds), and more than enough energy is provided for the TV cameras. Just how much the aperture plate temperature will rise when the diode is placed directly in front of the 0.667 mm aperture is still to be determined.

4. As use of an alternate source does not affect design of the optical portion of this assembly, final selection of this source is not necessary before the GFE TIS is available for testing (at which time, both source configurations can be evaluated under actual operating conditions).

PRECEDING PAGE BLANK-NOT FILMED

R&D STATUS REPORTS

No. 20 through No. 33

PHASE III

SYSTEM FABRICATION

June 1978 through November 1979

COMMON APERTURE TECHNIQUES
FOR
IMAGING ELECTRO-OPTICAL SENSORS (CATIES)
R&D STATUS REPORT NO. 20

I. GENERAL

This twentieth R&D Status Report describes the activities of GE/AESD in developing a Common Aperture Techniques for Imaging Electro-Optical Sensors (CATIES) Program under Contract F33615-76-C-1135, Item No. 0002, CDRL sequence 2.

II. TECHNICAL

A. SUMMARY

1. All vendor proposals for the Phase 3 optics fabrication were received by 15 May. Two vendors — Perkin-Elmer and Alpha — bid the complete system; two vendors — Alpha and Optical Systems and Technology, Inc. — bid just the glass. In addition, backup costs for glass, coatings, mechanical consultations, and optical consultations were received. Final evaluations are now in progress. (See figure 1.)
2. Questions from vendors (including those who have not bid) have been submitted to an independent consultant, Donald Kienholz, for analysis. Preliminary inputs have been received; a summary of his findings will appear in the next report.
3. Mechanical fabrication drawings for non optical-related parts are 95-percent complete, and will be finalized by the next report period. Fabrication of metal parts is about 20-percent complete.

4. All circuit boards (except for the Elevation Driver/Azimuth Preamplifier Assembly, A4, in the Interface Electronics Unit) have been laid out. Boards are partly assembled, but component delivery schedules will prevent final assembly before July.

5. Interfacing with GE/SSL (lead vapor laser) and Galileo (third generation intensifier power supply) has begun.

6. All CDR Action Items have been answered.

7. A formal cost and technical proposal for the display circuitry will be submitted to AFAL on 2 June 1978.

B. OPTICS

1. Of the ten optical firms solicited, only three submitted technical/cost proposals. Perkin-Elmer submitted a cost proposal updated from that presented at the CDR. This proposal was for the complete opto-mechanical package only, in either the full-up or the reduced-scope configuration. Alpha also submitted a proposal for the complete opto-mechanical package in either configuration, and an additional proposal for glass fabrication only. OSTI also submitted a proposal for glass fabrication only. These proposals were received about 2½ weeks late, and their content required more extensive analysis than anticipated.

2. Donald F. Kienholz, a private optical consultant, was asked to review design comments made by solicited vendors. Vendor questions

were primarily related to Narrow FOV MTF, glass selection, and tolerance analysis. These questions have all been assessed in a preliminary form, with a final summary to be included in next month's report. Briefly, however, the NFOV MTF is below specification values when using the night camera spectra; glass substitution for performance and cost is appropriate; a complete tolerance analysis is needed to aid final mechanical packaging. This work would be completed by the optics vendor early in phase 3. The advantage of performing this design optimization work is to give the optics vendor enough information about the design to allow him to guarantee some minimum performance on the hardware.

3. The scan mirror substrate will be in-house early in June, and ready for assembly by the next report period.

C. MECHANICAL

1. Fabrication drawings for non-optical related parts are 95-percent complete. Unfinished parts include the day camera adapter that fits into the focus/derotation mount, and the lead vapor illuminator interface. Once the phase 3 optics vendor is selected, all opto-mechanical details can be completed. These include cell mounting to optical bench, turret cell interfaces for the TV and illuminator relays, and common objective interface with the spectral separator.

2. Preliminary lead vapor laser interfaces have been established and sent to GE/SSL for comment. A meeting between AESD and SSL has been set-up for detailed discussions. Results from this meeting will be documented in next month's report.

3. Metal parts for the optical filter module, focus/derotation mount, console control panels, and optical bench are being fabricated in the model shop, and should be nearly assembled by the end of the next report period.

D. ELECTRICAL

1. With the exception of the A4 assembly board in the Interface Electronics Unit, all circuit boards have been laid-out, and on all boards requiring point-to-point wiring, sockets and terminal posts have been mounted.

2. Component deliveries are expected to run through July. The boards mentioned in paragraph 1. will not be completely assembled and tested for several months.

3. Connector shipments are being expedited. Partial deliveries are expected during the next reporting period. Cables will be fabricated as connectors are received.

4. The Control Console and Interface Electronics Unit wiring harnesses will be started during the next reporting period. Both the console and interface unit mechanical assemblies will be in-house in June.

COMMON APERTURE TECHNIQUES
FOR
IMAGING ELECTRO-OPTICAL SENSORS (CATIES)
R&D STATUS REPORT NO. 21

I. GENERAL

This twenty-first R&D Status Report describes the activities of GE/AESD in developing a Common Aperture Techniques for Imaging Electro-Optical Sensors (CATIES) Program under Contract F33615-76-C-1135, Item No. 0002, CDRL sequence 2.

II. TECHNICAL

A. SUMMARY

1. After reviewing all vendor proposals, Alpha Optical Systems, Inc. was recommended as the phase 3 optics vendor for the fabrication of a reduced scope optical subsystem. This recommendation was based on cost. However AESD did request that additional minimal funding be obtained to permit the subsequent addition of the LDR path, as the design already exists.
2. The results of the optical design report from independent consultant Donald Kienholz showed that the existing CATIES optical design was sensitive but could be fabricated with good optical shop practices. The polychromatic MTF in the NFOV TV leg was found to be less than specification goals with the night camera spectra.
3. Fabrication of metal parts is proceeding on schedule-- approximately 40% complete. Mechanical fabrication drawings for

non-optics-related parts will be completed in the next reporting period.

4. All eleven circuit boards have been laid out. Two circuit boards have been assembled completely, and one is underway. No electrical component delivery problems have been encountered.

5. The Control Console (see figure 1) was received from the vendor, and control panels are being fabricated. All switches, LED's, and knobs are on order, and should be received by August.

B. OPTICS

1. Based on cost considerations, a recommendation to procure the reduced-scope optical subsystem from Alpha was made to the Air Force Avionics Laboratory on June 16th. AESD is awaiting final decision from the Air Force on the vendor and configuration of the optical subsystem. Both Perkin-Elmer and Alpha were considered technically qualified for the remaining tasks. AESD did recommend that the Air Force seek alternate sources of funds to incorporate the LDR path at a later time. The optical subsystem modular concept will permit the addition of the LDR path later in the test program.

2. The optical design report from Donald Kienholz is included in Appendix A of this report. The design report identifies the five most sensitive surfaces for tilt, decentering, radii, axial thickness, index, and dispersion. As a supplement to this report, Mr. Kienholz will provide a relative ranking of these surfaces to the perturbations

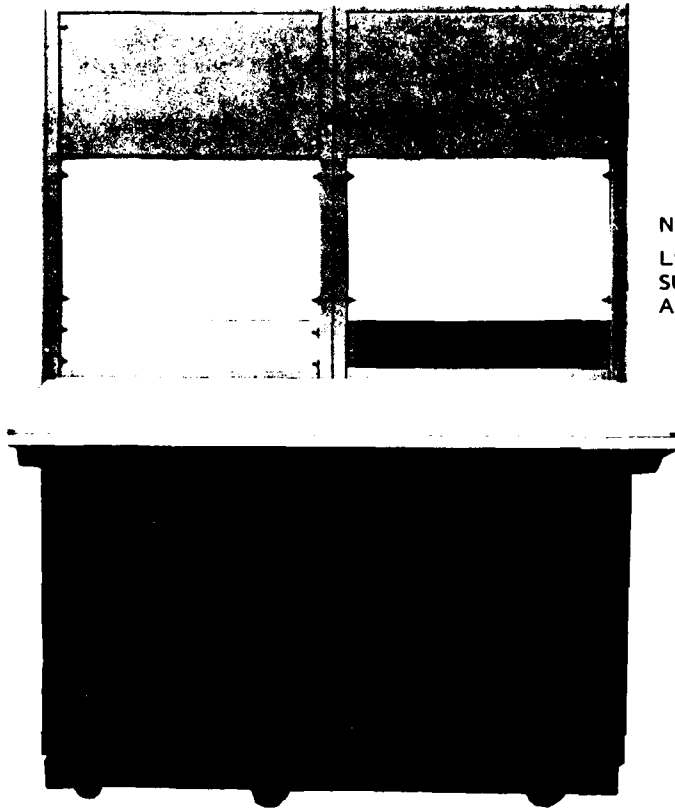

NOTE:
LINE DRAWINGS (SEE DETAIL)
SUGGEST PANEL PLACEMENT
AND LAYOUT

PANEL DETAIL

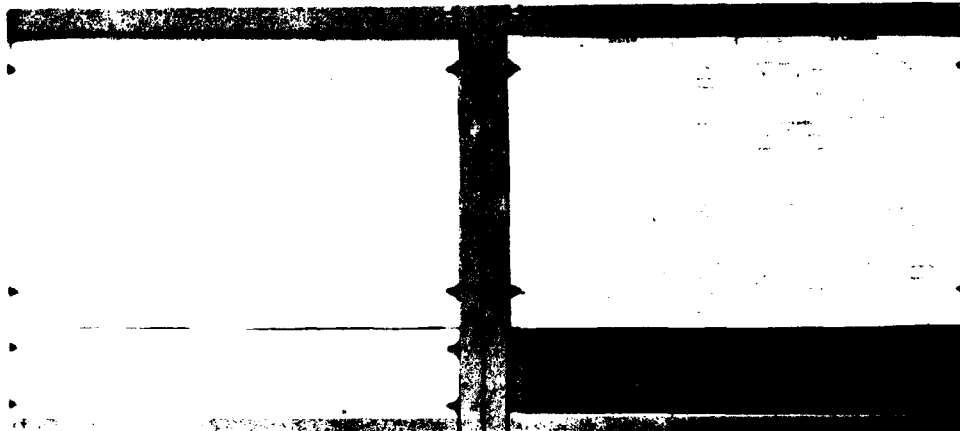

Figure 13. Control Console

identified. A first attempt to correlate the perturbations to the final image plane was unsuccessful because only on-axis MTF was evaluated. A more extensive analysis was not considered cost-effective at this time. Spherochromatism (i.e., variation in spherical aberration with wavelength) in the common objective was the limiting factor that caused the MTF in the NFOV to fall short of specification goals. Secondary color was very well controlled -- probably to the detriment of spherochromatism. A supplemental report answering several questions, and supplying clarifications, will be delivered and included in next month's report.

3. The scan mirror has been received, and is being processed. A breakdown in Schott's edging machines required that irregular, oversized blanks be edged in-house. This additional task, along with the hardness of the substrate (which requires additional polishing time), has resulted in an approximate two-week delay in the scan mirror completion. This is not a critical path on the program.

C. MECHANICAL

1. The optical bench support has been fabricated; it must be anodized, assembled, and painted. The azimuth bearing has been mounted on the frame for initial preassembly and alignment. The optical bench will be finished during the next reporting period.

2. All parts are complete for the Optical Filter Module/ Automatic Light Control Assembly, and assembly has started. The spectral filters are in-house, but will not be processed until the scan mirror is complete.

3. The scan assembly metal parts are complete.

4. The spectral separator/ TIS mount housing is in progress, but requires additional detailed drawings.
5. The Focus/ Derotation Mount is nearly complete. Gear blanks and bearings have been received from outside vendors, and final machining is in progress.
6. The Control Panels are being fabricated, and will be completed during the next reporting period.
7. Metal parts for the boresight spot are nearly complete. The source section will not be built until tests with the TIS and TV are complete. (Refer to Status Report No. 19, Paragraph F.)

D. ELECTRICAL

1. Assembly of components on the circuit boards is in progress. Two of the eight boards in the Interface Electronics Unit are complete (less testing). The one board in the Control Console is partly assembled. Of the boards remaining, two are point-to-point wired; the others have printed-wire runs, which allow faster assembly.
2. There are no delivery problems with electrical components, Connectors, motors, and servo potentiometers remain the longest lead items, with final deliveries expected in August.

AD-A087 558

GENERAL ELECTRIC CO UTICA NY AEROSPACE ELECTRONIC SY--ETC F/G 20/6
COMMON APERTURE TECHNIQUES FOR IMAGING ELECTRO-OPTICAL SENSORS --ETC(U)
FEB 80 F33615-76-C-1135

UNCLASSIFIED

79-556C0-10

AFWAL-TR-80-1012

NL

3 of 4
MIA
0-7552

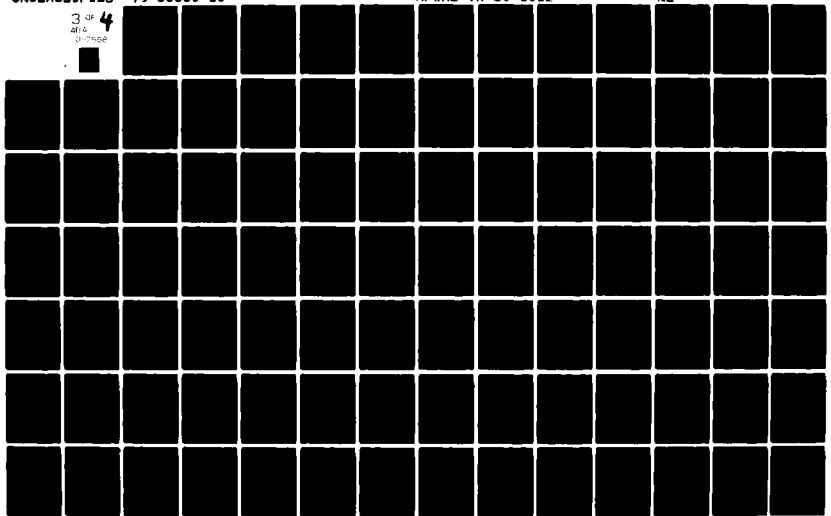

COMMON APERTURE TECHNIQUES
FOR
IMAGING ELECTRO-OPTICAL SENSORS (CATIES)
R&D STATUS REPORT NO. 22

I. GENERAL

This twenty-second R&D Status Report describes the activities of GE/AESD in developing a Common Aperture Techniques for Imaging Electro-Optical Sensors (CATIES) Program under Contract F33615-76-C-1135, Item No. 0002, CDRL sequence 2.

II. TECHNICAL

A. SUMMARY

1. As the GE/Utica plant was scheduled for a two-week vacation shutdown during the latter part of this report period (i.e., last full week in July and first week in August), efforts were directed at starting the Phase III optical fabrication portion of the program to allow vendor tasks to proceed without delay or interruption. Meetings for this purpose were held with Alpha Optical Company and with Frank Mitchell Associates. The first Phase III Optical Assembly review is planned for the week of August 21st, at Ocean Springs, Mississippi.
2. Additional design tolerance data supplied by consultant Don Kienholz appear in Appendix C of report No. 22.
3. At a meeting held at GE/SSL, Valley Forge, Pennsylvania, for establishing the CATIES lead-vapor illuminator interface, it was revealed that raw beam characteristics currently accommodated by the optical assembly insertion path may change.

4. In-house fabrication of mechanical piece-parts and circuit boards is continuing. Subassembly construction has been carried to various stages of completion, to the degree permitted by purchased part deliveries and Model Shop work loads.

B. OPTICS

1. A meeting with Alpha Optical Systems Incorporated was held in Utica on July 6th and 7th to review a revised Statement of Work for the Optical Fabrication Phase of the program. Minutes of this meeting appear in Appendix A of report No. 22 the revised Statement of Work appears in Appendix B.

2. Alpha Optical Systems was officially authorized on July 19th to proceed with the fabrication phase of the program; an initial design review is scheduled for the week of August 21st, at Ocean Springs, Mississippi. Intermediate and final design reviews have been tentatively scheduled for some time during the weeks of September 18th and October 16th respectively.

3. In subsequent telephone conversations with Alpha Company about the lead vapor illuminator optics, it was agreed that Alpha investigate feasibility criteria for incorporating a reverse-zoom Galilean telescope instead of a turret mechanism with far field uniformity being the basis for selection. In the new configuration, the "illuminator focus lens assembly" would remain unchanged, and the collimating lens assemblies would be replaced by a four-element or six-element zoom assembly. This technique provides maximum versatility for attaining desired fields-of-view, even when the laser raw beam divergence differs from the specified design values (refer to paragraph E.2). This configuration may also

again permit the four illuminator fields-of-view originally considered for the full-up system. Alpha Company inputs for making this decision will be presented at the initial review meeting.

4. It was also agreed that design optimization and evaluation would be performed using the night camera spectral response characteristics. This sensor was chosen because the spectral response in the 650 through 900 nanometer band is higher; substantial amounts of energy above 900 nanometers would be "filtered-out" by the dichroic plate (see optical schematic diagram in CRD book), and it is most sensitive to modulus changes.

5. Alpha Company informed GE/AESD that it could direct a print-out of the lens performance or prescriptions to Donald Kienholz or to WPAFB, as all use the Genesee computer services. Details for transferring print-outs to Donald Kienholz are in progress, and should be complete before the initial design review.

6. An addendum to Donald Kienholz's Tolerance Analysis (Appendix A of Monthly R&D Status Report No. 21) appears in Appendix C report No. 22. The addendum quantifies the relative sensitivity of each surface with respect to the various perturbations (e.g., decentering, tilt). Ray fans for the 0.8 and 0.9 micron wavelengths are included, and indicate that both are adding significant image errors to the optical system. Both the basic report and the addendum have been supplied to Alpha for use in its "Baseline Design Analysis." (Refer to Statement of Work, Task 1 in Appendices A and B.)

7. A meeting was held on July 19 and 20 with Frank R. Mitchell and

Associates, mechanical design consultants, to review work tasks and the system optical schematic diagram. This consultant is now under contract on the CATIES program. A general mechanical concept layout will be available for review concurrent with the initial design review at Alpha Company.

8. A summer shut-down at the coating vendor's facility will prevent coating of the scan mirror before the week of August 14th. Enhanced aluminum with a protective overcoat has been selected for this coating because of its high reflectance and excellent durability characteristics. The enhanced aluminum reflectance curve dips slightly, at 0.85 micron, below a standard aluminum metal coating, but is higher across the visible spectrum and at the lead vapor illuminator wavelength. Both coatings are in the same IR band, but in the near IR wavelengths (≈ 1.06 micron), the enhanced aluminum is slightly lower.

9. A Statement of Work for purchasing, fabricating, and coating the spectral separator was written, and sent to three vendors (Exotic Materials, Unique Optical, Spectrum System) for price and delivery quotations.

C. MECHANICAL

1. The optical bench has been painted and moved up to the laboratory. The pointing mirror elevation drive and azimuth roll bearing were assembled and installed on the bench to verify correctness of all dimensions. When the pointing mirror and separator housing are complete,

the entire unit will be transported to the large granite slab at the GE/AESD French Road facility, for final assembly and alignment.

2. The full 12-inch diameter pointing mirror front surface has been ground and polished to one-tenth wave accuracy. The substrate was then rough-cut to its final form, and the edges smoothed to proper dimensions.

This unit is ready for coating. (Refer to paragraph B8..)

3. The spectral filters for the filter wheel have been edged to diameter, and beveled. These filters will be sent out for coatings during the next report period.

D. ELECTRICAL

1. Available components have been mounted on six printed-circuit boards. These boards include two camera electronic sync generator assemblies, the control console electronics/logic board, and three boards from the interface electronics unit. Of the last three boards, testing is completed for the video mixer and the split sync/reticle generator boards.

2. Some component and connector deliveries continue to be a problem. A list of these items has been sent to the GE purchasing department for expediting.

E. MEETINGS

1. Three meetings (refer to figure 1) were held during this report period.

2. A trip report for the meeting at SSL appears in Appendix D of Status Report No. 22. Of most significance was the suggestion that it may be necessary to increase the beam diameter and divergence to achieve the required power output. These parameters must be finalized before Alpha proceeds with its final recomputations.

ATTENDEES

<u>DATE AND PLACE</u>	<u>GE/AESD</u>	<u>OTHERS</u>	<u>MAIN PURPOSE</u>
6,7 July 1978 GE, Utica, NY	J. Juliano D. Pultorak M. Kolesa P. Wing	J. Fahnestock G. Martin	Review Phase III Statement of Work
13 July 1978 GE/SSL, Valley Forge, PA	D. Pultorak M. Kolesa A. Lamphear	J. Bricks	CATIES Lead Vapor Illuminator Mechanical/ Electrical Interface and Environmental Considerations Discussion
19,20 July 1978 GE, Utica, NY	M. Kolesa	F. Mitchell	Review All Drawings and Documents Prepared to Date, and Start Vendor Working

Figure 1. Meeting Summary for July 1978
Report Period

11 July 1978

APPENDIX A TO R&D STATUS REPORT NO. 22

P. H. Wing, Sr. Buyer
Subcontracts
M.D. 606

MINUTES OF MEETING WITH ALPHA ON JULY 6 and 7, 1978

An updated Statement of Work (SK56079-16-84-22 Rev A) on the Phase 3 CATIES Optical Subsystem was reviewed at a meeting with Alpha Optical Systems, Inc. This memo documents the discussions which took place at that meeting. Attendees at the meeting were:

ALPHA

John Fahnstock
Gay Martin

AESD/GE

Pete Wing
Jim Juliano
Mike Kolesa
Dan Pultorak

The discussions were held and are documented in accordance with the Statement of Work (SOW) tasks.

1. TASK 1: DESIGN ANALYSIS OF THE BASELINE OPTICAL DESIGN

Alpha's proposal included an evaluation of the Laser Designator Ranger and Laser Illuminator Paths. Alpha raised a concern about the air focus on the laser paths. (A subsequent discussion with Dr. B. G. Bricks, SSL/GE, confirmed that there would be no problem with the lead vapor laser and he was not sure about the Nd:YAG laser designator). It was agreed that any air breakdown analysis on either laser path was beyond the scope of this task. Alpha will evaluate, as part of the performance analysis on the laser designator and illuminator paths, the far field uniformity pattern. Only the 16 mrad path (item numbers 30, 31 and 32) will be evaluated of the four possible illuminator paths. Single bounce secondary imaging analyses in the laser paths will be performed by Alpha. The contents of the Design Analysis Report were reviewed and included in the SOW task write-up.

2. TASK 2: DETAILED DESIGN OPTIMIZATION/MELT REAMPUTATION

The Laser Designator will be updated if any changes in the common objective are made.

3. TASK 3: SUBSTRATE ORDERING

OKAY

MEMO
11 July 1978
Page 2

4. TASK 4: OPTICAL ELEMENT FABRICATION/COATING

ALPHA has recommended a split in the coating work between Herron and Valtec. This has a cost impact. A final decision on the recommendation has been delayed until the Initial Design Review.

5. TASK 5: SPECTRAL SEPARATOR FABRICATION/COATING

A final decision as to whether this is to be included as a task on Alpha has been delayed until July 21st.

6. TASK 6: MECHANICAL CELL DESIGN

A table will be added which defines the mechanical cells to be delivered. This list is written around the baseline optical design and will be finalized at the Intermediate Design Review. Alpha has agreed to deliver residual glass material.

7. TASK 7: ASSEMBLY/ALIGNMENT

OKAY

8. TASK 8: DESIGN REVIEWS

An Intermediate Design Review was added to the list of reviews. The date of the reviews was tentatively scheduled as 5, 9 and 13 weeks ARO (FW 34, 38 and 42 respectively).

9. TASK 9: ACCEPTANCE TEST PROCEDURE/REPORT

OKAY

10. TASK 10: MAJOR MILESTONE PLAN

OKAY

In addition, AESD engineering agreed to deliver to Alpha the following documents:

1. Preliminary Design Review Booklet
2. Critical Design Review Booklet plus Supplement
3. Donald Kienholz's Tolerance Analyses Report
4. Marked up Specification identifying potential areas for change.

MEMO
11 July 1978
Page 3

If there are any changes, corrections or additions to these minutes, please call me.

James F. Juliano

James F. Juliano
Advanced Systems Engineering
Extension 5523
M.D. 908

/jp

1.0 SCOPE

THIS STATEMENT OF WORK DEFINES THE WORK TASKS TO BE PERFORMED BY THE VENDOR IN SUPPORT OF AEROSPACE ELECTRONIC SYSTEMS DEPARTMENT/GENERAL ELECTRIC COMPANY, HEREINAFTER REFERRED TO AS THE BUYER. THIS SUPPORT IS RELATED TO AN OPTICAL SUBSYSTEM DESIGNED UNDER A PREVIOUS CONTRACT AND HEREINAFTER REFERRED TO AS THE BASELINE OPTICAL SUBSYSTEM. THE VENDOR SHALL BE RESPONSIBLE BY WORK TASK FOR DESIGN FABRICATION, ASSEMBLY, ALIGNMENT AND TEST OF OPTICAL ELEMENTS IN CELLS WHICH WHEN MOUNTED IN AN AGREED UPON MECHANICAL CONFIGURATION SHALL MEET THE REQUIREMENTS OF SK56079-16-84-13, HEREINAFTER REFERRED TO AS THE SPECIFICATION. AS A POINT OF DEPARTURE, THE VENDOR SHALL USE THE BASELINE DESIGN DESCRIBED IN SK56079-16-84-12G1 AND SK56079-16-84-14. THE BUYER WILL MOUNT THE BUYER ACCEPTED CELLS IN A BRASS-BOARD LABORATORY SYSTEM.

2.0 APPLICABLE DOCUMENTS

THE FOLLOWING DOCUMENTS OF ISSUE IN EFFECT ON THE DATE OF INVITATION TO BID SHALL FORM A PART OF THIS STATEMENT OF WORK TO THE EXTENT SPECIFIED HEREIN OR IN SUBSIDIARY DOCUMENTS. IF ANY CONFLICTS EXIST BETWEEN ANY OF THE REFERENCE DOCUMENTS AND THIS STATEMENT OF WORK, THE FOLLOWING ORDER OF PRECEDENCE APPLIES:

1. THE PURCHASE ORDER
2. THIS STATEMENT OF WORK
3. SPECIFICATION SK56079-16-84-13
4. DRAWINGS SK56079-16-84-12
5. LAYOUT SK56079-16-84-14

2.1 MILITARY STANDARDS

MIL-STD-34 - PREPARATION OF DRAWINGS FOR OPTICAL ELEMENTS AND OPTICAL SYSTEMS

MIL-STD-150A MILITARY STANDARD PHOTOGRAPHIC LENSES

AESD1040-F REV (4-74) V

GENERAL  ELECTRIC AESD • UTICA, N.Y.	SIZE	CODE IDENT NO.	SK 56079-16-84-22
	A	99971	PHASE 3 OPTICS STATEMENT OF WORK
	SCALE	REV.	SHEET 2



2.2 GENERAL ELECTRIC SPECIFICATIONS

SK56079-16-84-12 - OPTICAL ELEMENT DRAWINGS

SK56079-16-84-13 - OPTICAL SUBSYSTEM, COMMON APERTURE SYSTEM,
SPECIFICATION FOR

SK56079-16-84-14 - OPTICAL SUBSYSTEM, LAYOUT FOR

3.0 CONTRACT TASKS

THE FOLLOWING CONTRACT TASKS AS SPECIFIED IN THE PURCHASE ORDER SHALL
BE PERFORMED BY THE VENDOR IN ACCORDANCE WITH THIS STATEMENT OF WORK.

3.1 TASK 1: DESIGN ANALYSIS OF THE BASELINE DESIGN

THE VENDOR SHALL PERFORM A PRELIMINARY DESIGN ANALYSIS FOR THE BASELINE
OPTICAL DESIGN. THIS ANALYSIS SHALL INCLUDE A TOLERANCE ANALYSIS AND
OPTICAL PERFORMANCE PREDICTIONS. THE VENDOR SHALL DRAW CONCLUSIONS AND
MAKE RECOMMENDATIONS TO THE BUYER FOR REVIEW AND APPROVAL FOR DESIGN
CHANGES WHICH WOULD REDUCE THE COST OF THE OPTICS OR IMPROVE PERFORMANCE.
A DESIGN ANALYSIS REPORT SHALL BE GENERATED ON VENDOR FORMAT WHICH SHALL
INCLUDE AS A MINIMUM THE FOLLOWING:

- A. COMPUTER INPUT/OUTPUT DATA USED TO JUSTIFY
RECOMMENDATIONS AND CONCLUSIONS
- B. RAY TRACE DATA USED IN PERFORMANCE PREDICTIONS
- C. RECOMMENDATIONS AND CONCLUSIONS
- D. WRITTEN TEXT TO EXPLAIN DATA

3.2 TASK 2: DETAILED DESIGN OPTIMIZATIONS/MELT RECOMPUTATIONS

WHERE BUYER APPROVED CHANGES TO THE BASELINE OPTICAL SUBSYSTEM HAVE BEEN
MADE, THE VENDOR SHALL PERFORM A DETAILED OPTICAL REDESIGN/OPTIMIZATION.
ELEMENT DRAWINGS AND OPTICAL LAYOUTS SHALL BE UPDATED IN ACCORDANCE WITH
THESE REDESIGNS/OPTIMIZATIONS. MELT RECOMPUTATIONS SHALL BE MADE BY THE
VENDOR. ELEMENT DRAWINGS AND OPTICAL LAYOUTS SHALL BE UPDATED IN

GENERAL ELECTRIC
AESD • UTICA, N.Y.

SIZE CODE IDENT NO.
A 99971

SK 56079-16-84-22

PHASE 3 OPTICS STATEMENT OF WORK

SCALE

REV.

SHEET 3

ACCORDANCE WITH THE RECOMPUTATION. ALL DRAWING CHANGES MADE BY THE VENDOR SHALL BE IN ACCORDANCE WITH MIL-STD-34 AND SHALL BE SUBMITTED TO THE BUYER FOR APPROVAL.

3.3 TASK 3: SUBSTRATE ORDERING

THE VENDOR SHALL ORDER ALL SUBSTRATES REQUIRED TO FABRICATE THE ELEMENTS DEFINED IN THE BUYER APPROVED SK56079-16-84-12G2 ELEMENT DRAWINGS. THE VENDOR MAY SUBSTITUTE DIFFERENT GLASS TYPES FROM THOSE IDENTIFIED PROVIDED THAT IT IS WITH CONCURRENCE OF THE BUYER.

3.4 TASK 4: OPTICAL ELEMENT FABRICATION/COATING

THE VENDOR SHALL FABRICATE AND COAT ONE (1) SET OF OPTICAL ELEMENTS IN ACCORDANCE WITH THE BUYER APPROVED ELEMENT DRAWINGS, SK56079-16-84-12G2.

3.5 TASK 5: SPECTRAL SEPARATOR FABRICATION/COATING

THE VENDOR SHALL FABRICATE AND COAT OR HAVE COATED ONE (1) SPECTRAL SEPARATOR IN ACCORDANCE WITH SK 56079-16-84-12G3. THE VENDOR SHALL SUPPLY THE SUBSTRATE MATERIAL.

3.6 TASK 6: MECHANICAL CELL DESIGN

THE VENDOR SHALL BE RESPONSIBLE FOR THE DESIGN AND FABRICATION OF THE MECHANICAL CELLS AND SPACERS AND RETAINERS REQUIRED TO MOUNT THE SK56079-16-84-12G2 OPTICAL ELEMENTS IN ORDER TO MEET THE SPECIFICATION. DRAWING GENERATED AS PART OF THIS TASK SHALL BE ON VENDOR FORMAT AND SHALL BE DELIVERABLE TO THE BUYER.

3.7 TASK 7: ASSEMBLY/ALIGNMENT

THE VENDOR SHALL ASSEMBLE AND ALIGN THE OPTICAL ELEMENTS FABRICATED AND COATED IN TASK 4 INTO THE CELLS DESIGNED AND FABRICATED IN TASK 6. THE FINAL ASSEMBLIES SHALL MEET THE APPROPRIATE PERFORMANCE REQUIREMENTS OF THE SPECIFICATION.

Y
AESD10401-F REV (4-74) V

GENERAL ELECTRIC AESD • UTICA, N.Y.	SIZE	CODE IDENT NO.	SK 56079-16-84-22
	A	99971	PHASE 3 OPTICS STATEMENT OF WORK
	SCALE	REV.	SHEET 4

↑
200

3.8 TASK 8: DESIGN REVIEWS

THE VENDOR SHALL PARTICIPATE IN THREE (3) INFORMAL DESIGN REVIEWS TO BE HELD AT THE VENDOR'S FACILITY. IT IS ANTICIPATED THAT AIR FORCE AVIONICS LABORATORY PERSONNEL WILL ATTEND THESE REVIEWS.

3.8.1 TASK 8.1 INITIAL DESIGN REVIEW (IDR)

AN INITIAL DESIGN REVIEW SHALL BE HELD APPROXIMATELY 5 WEEKS ARO.

3.8.1.1 VENDOR PARTICIPATION

THE VENDOR SHALL PRESENT TO THE BUYER THE CONCLUSIONS AND RECOMMENDATIONS FROM THE DESIGN ANALYSIS (TASK 1). THE VENDOR SHALL SUPPLY TO THE BUYER COPIES OF THE DESIGN ANALYSIS REPORT AT THIS IDR. THE VENDOR SHALL PREPARE AND SUBMIT TO THE BUYER MINUTES OF THE IDR WITHIN FIVE (5) DAYS OF THE REVIEW.

3.8.1.2 BUYER PARTICIPATION

THE BUYER SHALL PROVIDE AN OVERALL MECHANICAL LAYOUT CONCEPT FOR MOUNTING, MECHANIZING AND ALIGNING OF THE MECHANICAL CELLS INTO AN OPTICAL SUBSYSTEM. THIS CONCEPT WILL BE REVIEWED AT THE IDR.

3.8.1.3 APPROVAL TO PROCEED

THE VENDOR SHALL REQUIRE BUYER APPROVAL TO PROCEED WITH ANY WORK BEYOND THE PDR.

3.8.2 INTERMEDIATE DESIGN REVIEW (ImDR)

AN INTERMEDIATE DESIGN REVIEW SHALL BE HELD APPROXIMATELY 9 WEEKS ARO.

3.8.2.1 VENDOR PARTICIPATION

THE VENDOR SHALL PRESENT A STATUS ON THE WORK COMPLETED TO DATE. THE VENDOR SHALL IDENTIFY ANY LONG LEAD PARTS AT THIS REVIEW. THE VENDOR SHALL PREPARE AND SUBMIT TO THE BUYER MINUTES OF THE IMDR WITHIN FIVE (5) DAYS OF THE REVIEW.

3.8.2.2 BUYER PARTICIPATION

Y
AESD1001-F REV (4-74) ▽

GENERAL ELECTRIC AESD • UTICA, N.Y.	SIZE	CODE IDENT NO.	SK 56079-16-84-22 PHASE 3 OPTICS STATEMENT OF WORK
	A	99971	
	SCALE	REV.	SHEET 5

THE BUYER SHALL PROVIDE FINAL MECHANICAL CONCEPTS FOR MOUNTING, MECHANIZING, AND ALIGNING OF THE MECHANICAL CELLS INTO AN OPTICAL SUB-SYSTEM. THIS CONCEPT WILL BE REVIEWED AND AGREED UPON AT THIS REVIEW.

3.8.3 FINAL DESIGN REVIEW (FDR)

A FINAL DESIGN REVIEW SHALL BE HELD APPROXIMATELY 13 WEEKS ARO.

3.8.3.1 VENDOR PARTICIPATION

THE VENDOR SHALL PRESENT TO THE BUYER RESULTS OF THE DETAILED DESIGN OPTIMIZATIONS/MELT RECOMPUTATIONS (TASK 2) AND MECHANICAL CELL DESIGN (TASK 6). THE VENDOR SHALL SUPPLY COMPUTER INPUTS AND OUTPUTS USED TO ARRIVE AT THE PRESENTED RESULTS, UPDATED OPTICAL ELEMENT DRAWINGS AND MECHANICAL CELL/SPACER/RETAINER DRAWINGS. THE VENDOR SHALL PRESENT AN UPDATED SPECIFICATION WITH MINIMUM GUARANTEED PERFORMANCE FOR THE HARDWARE BASED ON THE PAPER DESIGN. AS A FIGURE OF MERIT, THE VENDOR SHALL USE 85% OF PAPER DESIGN IN GENERATING PERFORMANCE GUARANTEES EXCEPT IN AREAS WHEN THESE GUARANTEES WOULD EXCEED THE MINIMUM REQUIREMENTS OF SK56079-16-84-13.

3.8.3.2 APPROVAL TO PROCEED

THE VENDOR SHALL REQUIRE BUYER APPROVAL TO PROCEED WITH ANY WORK BEYOND THE CDR.

3.9 TASK 9: ACCEPTANCE TEST PROCEDURE/REPORT

THE VENDOR SHALL SUBMIT FOR REVIEW AND APPROVAL BY THE BUYER AN ACCEPTANCE TEST PROCEDURE. THIS PROCEDURE SHALL BE GENERATED ON VENDOR FORMAT. MIL-STD-150A SHALL BE USED AS A GUIDE IN GENERATING THIS PROCEDURE. ALL DELIVERABLE HARDWARE SHALL BE TESTED IN ACCORDANCE WITH THE APPROVED PROCEDURE. THE RESULTS OF THIS TEST SHALL ACCOMPANY THE HARDWARE AND SHALL CONSTITUTE AN ACCEPTANCE TEST REPORT.

Y

AESD10401-F REV (4-74) V

GENERAL ELECTRIC  AESD • UTICA, N.Y.	SIZE	CODE IDENT NO.	SK 56079-16-84-22
	A	99971	PHASE 3 OPTICS STATEMENT OF WORK
	SCALE	REV.	SHEET 6

3.10 TASK 10: MAJOR MILESTONE PLAN

THE VENDOR SHALL SUBMIT TO THE BUYER FOR APPROVAL A MAJOR MILESTONE PLAN.
THIS PLAN SHALL BE UPDATED PERIODICALLY THROUGHOUT THE PROGRAM.

4.0 QUALITY ASSURANCE PROVISIONS

THE VENDOR SHALL IMPLEMENT SUCH QUALITY ASSURANCE CONTROLS AS HE
DEEMS NECESSARY TO ASSURE THAT THE OPTICAL SUBSYSTEM SHALL MEET THE REQUIRE-
MENTS OF THE SPECIFICATION AND THIS WORK STATEMENT.

4.1 CONFIGURATION MANAGEMENT

THE VENDOR SHALL PROVIDE THE LEVEL OF CONFIGURATION MANAGEMENT NECESSARY
TO IDENTIFY THE BASELINE CONFIGURATION OF THE OPTICAL SUBSYSTEM AT THE
TIME OF DELIVERY.

4.2 PREROGATIVES OF THE BUYER

THE BUYER RESERVES THE RIGHT FOR THE BUYER OR OTHERS DESIGNATED BY THE BUYER
TO VISIT THE VENDOR'S FACILITIES FOR EXTENDED PERIODS OF TIME FOR THE PURPOSES
OF PROGRAM OR DESIGN REVIEWS, INSPECTION OF FACILITIES, WITNESSING OF TESTS
AND ANY OTHER REASONABLE PURPOSE RELATED TO THIS PROCUREMENT.

ALL RELATIONSHIPS BETWEEN THE VENDOR AND ANY OTHER OF THE BUYER'S VENDORS
OR THE ULTIMATE USER OF THE OPTICAL SUBSYSTEM INSOFAR AS THEY RELATE TO THE
CONDUCT OF THIS PROCUREMENT SHALL REQUIRE THE APPROVAL AND PARTICIPATION OF
THE BUYER.

5.0 DELIVERABLES

5.1 DATA

THE FOLLOWING DATA ITEMS SHALL BE SUBMITTED TO THE BUYER IN ACCORDANCE WITH
THE APPROPRIATE TASK DESCRIPTION.

DESIGN ANALYSIS REPORT
ELEMENT DRAWINGS

45 DARO
90 DARO

AESD10401.5 REV (4-74)

GENERAL ELECTRIC
AESD • UTICA, N.Y.

SIZE	CODE IDENT NO.
A	99971
SCALE	REV.

SK 56079-16-84-22
PHASE 3 OPTICS STATEMENT OF WORK

SHEET 7

MECHANICAL DRAWINGS	90 DARO
INITIAL DESIGN REVIEW MINUTES	5 DADR
INTERMEDIATE DESIGN REVIEW MINUTES	5 DADR
FINAL DESIGN REVIEW MINUTES	5 DADR
ACCEPTANCE TEST PROCEDURE	180 DARO
ACCEPTANCE TEST REPORT	217 DARO
MAJOR MILESTONE PLAN	30 DARO (with 30-day updates)

5.2 HARDWARE

THE FOLLOWING MECHANICAL CELLS SHALL BE DELIVERED TO THE BUYER. THIS CELL BREAKDOWN IS CONSISTENT WITH THE BASELINE OPTICAL SYSTEM. THIS CELL BREAKDOWN SHALL BE FINALIZED AT THE INTERMEDIATE DESIGN REVIEW:

COMMON OBJECTIVE	217 DARO
FIELD LENS	217 DARO
TRANSFER HOUSING	217 DARO
WFOV RELAY	217 DARO
NFOV RELAY	217 DARO
VNFOV RELAY	217 DARO
ILL. FOCUS LENS	150 DARO
NFOV COLLIMATING LENS	150 DARO
VNFOV COLLIMATING LENS	150 DARO
RESIDUAL GLASS	217 DARO

AESD10401-F REV (4-74) ▽

GENERAL ELECTRIC AESD • UTICA, N.Y.	SIZE A	CODE IDENT NO. 99971	SK 56079-16-84-22 PHASE 3 OPTICS STATEMENT OF WORK
	SCALE	REV.	SHEET 8

DONALD F. KIENHOLZ

OPTICAL ENGINEERING CONSULTANT

SLEEPER ROAD
HILLSBORO, NEW HAMPSHIRE 03244

TELEPHONE 603 - 478-5266

APPENDIX C TO R&D STATUS REPORT NO. 22

July 6, 1978

Mr. J. F. Juliano
General Electric Company
901 Broad St.
Utica, N.Y. 13503

Dear Jim:

Enclosed are ray plots for the CATIES objective lens and NFOV with plots added for .8 and .9 micrometer wavelengths. The .9 micrometer wavelength is really wild and I re-plotted axial NFOV to get it on the paper. The straight line which crosses the ordinate at $-.06$ mm corresponds to the $+3$ mm focus shift for the MTF plots. It appears from these plots that there is significant degradation at the long wavelengths and not much at .65 micrometers. The primary color correction probably should be between .65 and .8 micrometers unless you reduce the bandwidth at the lower wavelength end.

With regard to secondary color correction mentioned on page 4 of the report and in our telephone conversation of June 28, the approximate value of the blur circle radius due to secondary color for the objective lens only, with normal glasses, is the pupil radius divided by 2000 which is $.033$ mm. This is for the visual wavelength range of F to C spectral lines. For the reduced bandwidth from .65 to .76 micrometers the value would be .65 times this value, or $.021$ mm. The computed value is $.008$ mm so we can conclude that there is a reduction of 2.6 times due to the glasses used in the lens.

Also enclosed are tabulated values of normalized relative surface sensitivity factors of each type of variable. No values are given for air spaces 10, 12 and 31 which were used as focal shift compensators. Air space 15 has no value given as it is an insensitive parameter provided there is a focal shift compensation.

Each glass type was varied in index and dispersion and where glass types are repeated in the lens they were varied by a glass pickup so that each glass type has the same sensitivity factor in the table.

With regard to tilt sensitivity on surface 24 (surface most sensitive to tilt and decenter) an rms value of .25 wavelength path length error was generated by a tilt of .011 radian or 37 arc minutes. The tilt tolerance on element 13, P-E dwg 660-4515, which results from a 5 micrometer wedge is 0.19 milliradians or 40 arc seconds. This is a tight tolerance, but reasonable and practically achievable. Assembly of the elements of the relay lens will require care to assure that precise centering is maintained. It is recommended that centering be monitored during assembly with an interferometer to measure beam deviation rather than to rely on the concentricity of lens cell bores and edges of lens elements.

Sincerely,

Da

Enclosures.

SURFACE SENSITIVITY NORMALIZED FOR EACH PARAMETER TYPE

<u>P-E Surface Number</u>	<u>DEC.</u>	<u>TILT</u>	<u>RADIUS</u>	<u>THICK.</u>	<u>INDEX</u>	<u>DISPERSION</u>
1	.15	.25	1.0	.24	1.0	1.0
2	.05	.07	.21	.35	.41	.12
3	.01	.22	.54	.63		
4	.18	.51	.67	.03	.19	.29
5	.14	.30	.34	.08		
6	.03	.10	.08	.15	.52	.44
7	.01	.01	.02	.15	.49	.001
8	.04	.10	.16	.07		
9	.06	.20	.34	.02	1.0	1.0
10	.05	.23	.43			
11	.03	.07	.01	.03	.002	.001
12	.02	.05	.004			
14	.01	.09	.002	.02	.001	.001
15	.004	.04	.26			
16	.25	.4	.27	.03	.003	.002
17	.28	.42	.13	.07		
18	.08	.25	.11	.02	.41	.12
19	.10	.26	.06	.17		
20	.26	.42	.07	.25	.41	.12

<u>P-E Surface Number</u>	<u>DEC.</u>	<u>TILT</u>	<u>RADIUS</u>	<u>THICK.</u>	<u>INDEX</u>	<u>DISPERSION</u>
21	.17	.37	.05	.28		
22	.51	.57	.05	.65	.41	.12
23	.12	.18	.10	.30	.41	.32
24	1.0	1.0	.04	.15		
25	.52	.67	.06	1.0	.39	.22
26	.22	.26	.11	.49	.58	.61
27	.27	.44	.11	.04		
28	.01	.19	.06	.04	.58	.61
29	.11	.30	.11	.05		
30	.05	.14	.03	.02	.58	.61
31	.01	.21	.03			

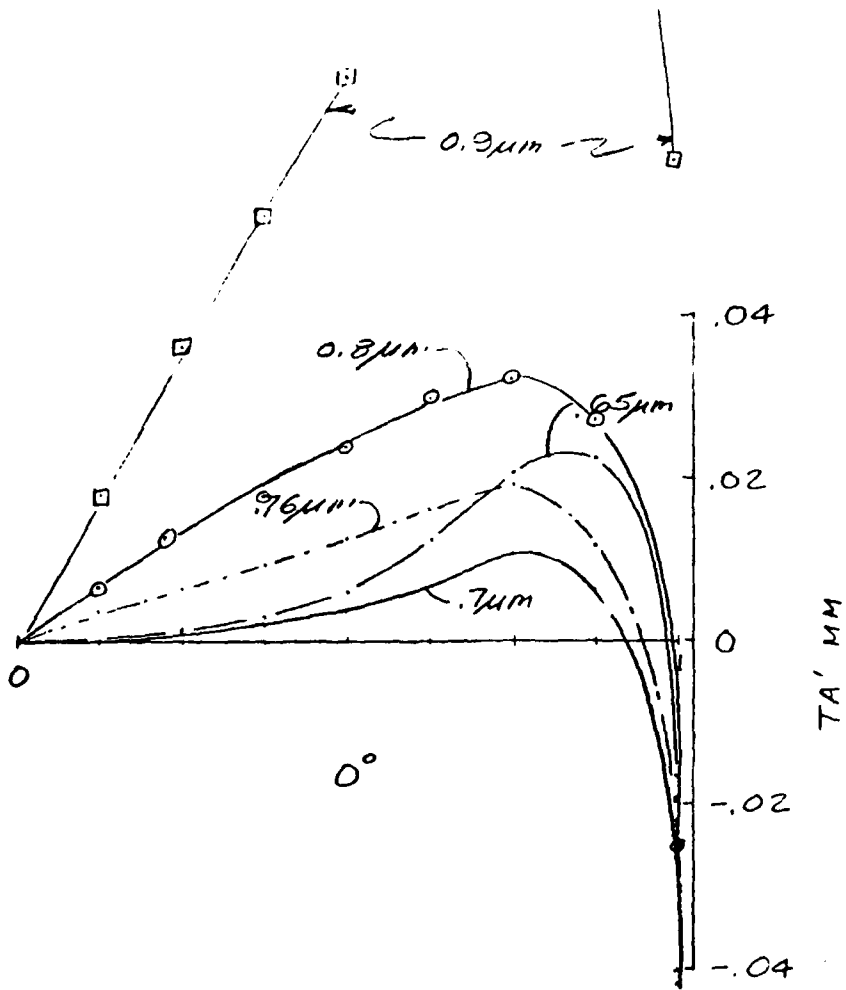

CATIES OBJECTIVE LENS
360 MM F/2.74

FIGURE 6

CATIES NFOV
266 MM F/2.5

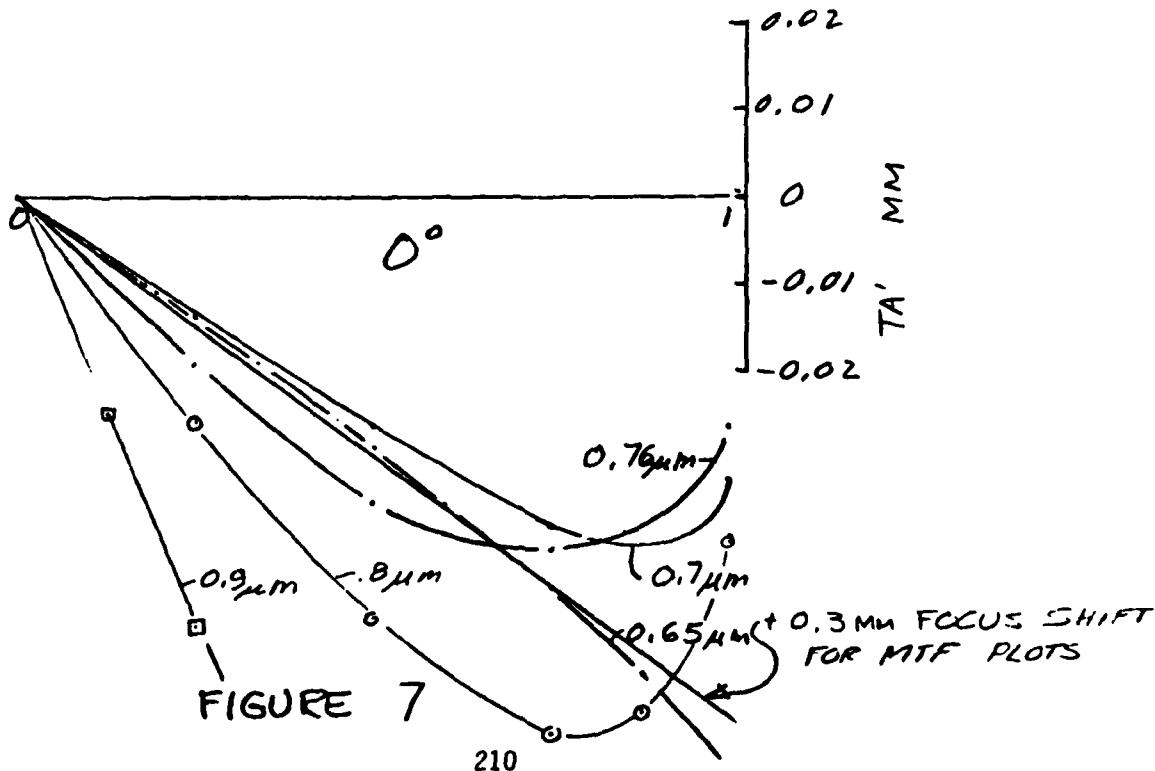
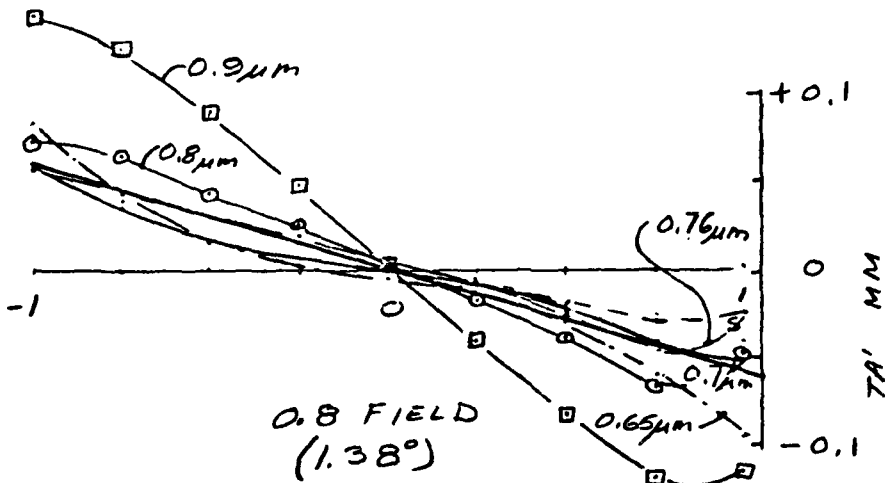
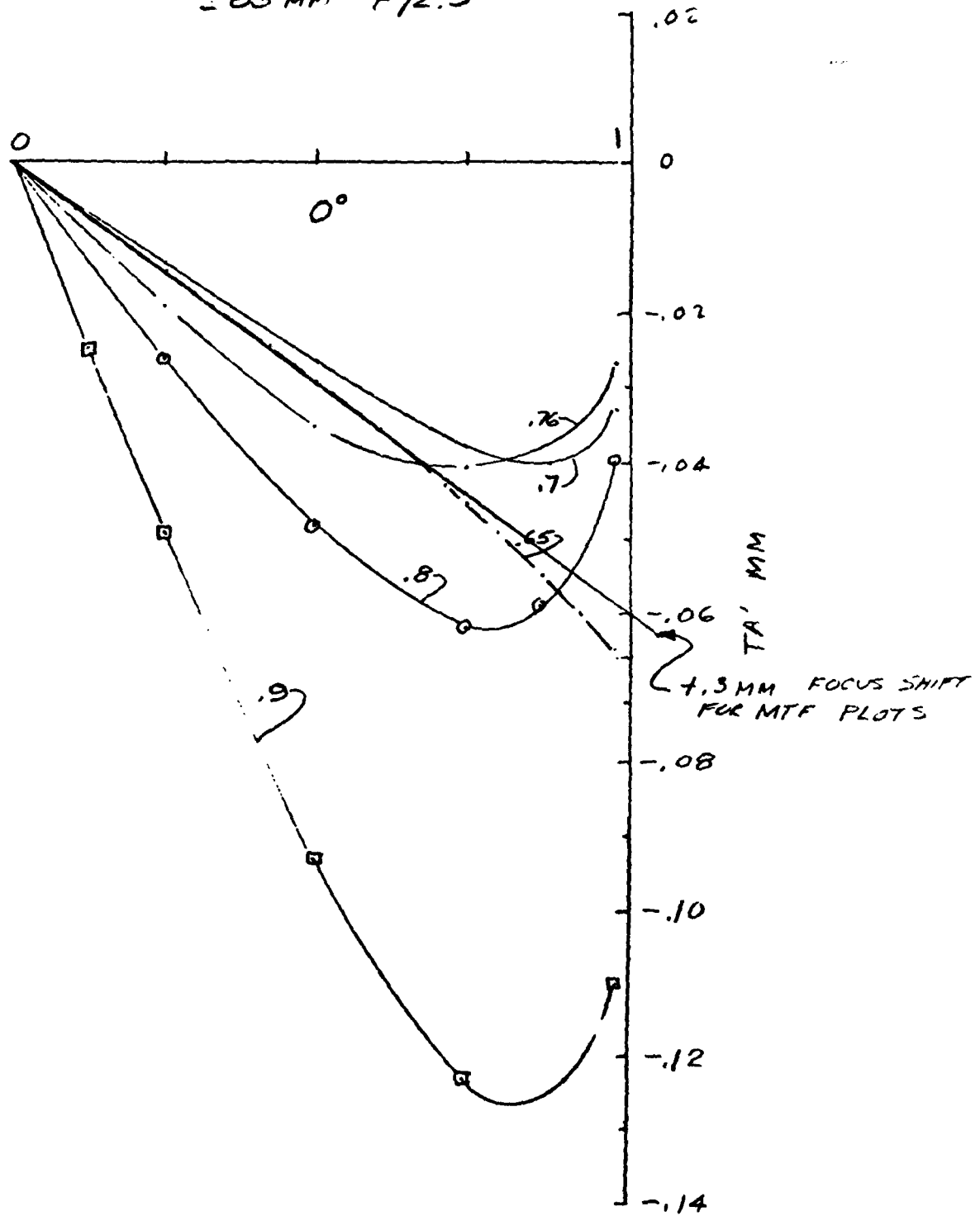

FIGURE 7

CATIES NIPDV AXIAL FAN-
 263 MM F/2.5



PRECEDING PAGE BLANK-NOT FILLED

APPENDIX D
TO
R&D STATUS REPORT NO. 22

GENERAL ELECTRIC

AEROSPACE ELECTRONIC SYSTEMS

TRAVELER: DAN PULTORAK	PLACE VISITED SSL/GE Valley Forge, Pa.	DATE 7/17/78
ACCOMPANIED BY: Mike Kolesa Al Lamphear	COPIES OF THIS REPORT TO J. Juliano R. Kies R. Sukackas J. Antonelli R. Knoeller R. H. Smith	
OBJECT OF VISIT: Establish packaging concept of PbV Illuminator compatible with CATIES configuration		DATE OF VISIT 7/13/78

The illuminator for CATIES will be built from all new materials. Some parts are already available at SSL, and some longer lead items have been ordered (glass, thyratron, high voltage components, etc.) Jerry has modified the existing demo laser-illuminator and operated it at 4.3 watts average power (up from previous high of 3.8 watts). The primary objective of their contract with the Air Force is to deliver a 4 watt air-cooled illuminator. He is pretty confident at this time that in order to do this, the raw output beam divergence will have to increase by approximately 50% to 7 or 8 milliradians. This change will have to be factored into the laser insertion optical path design prior to the final melt recomputation for the optical assembly.

REPORT

The pulse forming generator will be designed and built by SSL. It will be housed in the intermediate control console which will also be supplied by SSL. This console (approximately 25" H x 22" W x 14 1/2" D, on casters) will contain vacuum and temperature monitoring meters, primary power controls and the internal free running oscillator circuit so that the illuminator can be operated and tested without having the camera electronics unit in the system. Input power will be hard-wired into the console as required. The high voltage D.C. power supply which is a separate unit is a GFE item and will be shipped directly from Dayton to Utica. (mechanical and electrical data on this 10kw Electro-Power pac supply was received prior to this meeting).

Jerry Bricks feels that a September delivery to the Air Force is very tight, but is still possible. A review of the CATIES schedule indicated that a delivery of the illuminator any time prior to early November probably would not impact the program since turning mirrors, shutter assembly and optics are not scheduled for completion until this time).

The following points were brought out in the discussions:

1. All cables and exit port will be moved to the bottom of the illuminator head assembly. The unit will mount on legs 6 to 8" high to allow clearance for cables and vacuum connector.
2. Shutter should act as a failsafe and should be mounted on outside of the illuminator head front surface. The solenoid should be powered during normal operation (open position). The solenoid should be located above or adjacent to output beam port rather than below, since rising warm air currents tend to alter beam characteristics.

Trip Report
SSL/GE Valley Forge, Pa.
(July 13, 1978)

Page 2

3. Entire illuminator head with housing will weigh approximately 100 pounds (60" long x 15" wide x 12" high). Output axis will be a minimum of 4" above bottom of unit.

4. Five or more blower fans will be required for cooling.

5. Three turning mirrors will be required for laser insertion. Provision should be made to easily insert a calorimeter for power checks and to calibrate the photo detector mounted on the laser side of the shutter. This must be done so HV DC power supply adjustments can be made as necessary during operation to maintain peak output power of the laser beam. Additional interfacing will be required to establish the shutter /1st turning mirror at the output and of the illuminator.

6. Heat fin requirements at the window ends will be supplied by GE. Cooler window will be used as the exit for the laser beam.

7. Helium tank and pressure regulator are not deliverable items. They must be supplied at each test location. Regulator output pressure is less than 10 pounds.

8. Vacuum pump usually can be made to run on either 220 volts or 110 volts. GE will be notified if there is any change to input power requirements, since this GFE item will be shipped directly to SSL.

9. The illuminator will not require 28 VDC primary power. Low voltages required will be generated in the intermediate console from 110 line voltage.

10. SSL will consider mounting the thyratron in a screened enclosure outside the illuminator head enclosure. The 15" dimension could be significantly reduced if this approach is feasible.

Dan Pultorak
Dan Pultorak

Mike Kolesa
Mike Kolesa

/jip

COMMON APERTURE TECHNIQUES
FOR
IMAGING ELECTRO-OPTICAL SENSORS (CATIES)

R&D STATUS REPORT NO. 23

I. GENERAL

This twenty-third R&D Status Report describes the activities of GE/AESD in developing a Common Aperture Techniques for Imaging Electro-Optical Sensors (CATIES) Program under Contract F33615-76-C-1135, Item No. 0002, CDRL sequence 2.

II. TECHNICAL

A. SUMMARY

1. During the GE two-week vacation shutdown, enough key purchased parts were received to allow assembly and operation of several complex modules associated with the TV cameras. Two technicians have been assigned full-time to prepare cables, and to assemble and test the remaining circuit boards.
2. A visitation to the GE facility was made by James Stewart (USAF) to observe the work completed to date, and to tour the proposed test site (at Cazenovia, NY).
3. This report period marks the transition of project responsibility to Daniel Pultorak. James Juliano will continue to monitor developments throughout the control phase of optics fabrication,

and will assist as required during the program test phase.

4. The first of three design review meetings regarding CATIES optical assembly fabrication was held in Ocean Springs, Mississippi. Alpha's evaluation of the baseline design and recommendations for a new common objective assembly and zoom lens for the lead vapor illuminator were reviewed. Questions arising during this meeting were subsequently investigated and answered by Alpha and the GE optical consultant during the one-week hold provided by the control program. When it was determined that the proposed design would allow achieving predicted levels of performance without creating new problems, a go-ahead for the next program phase was given to Alpha.

5. A meeting was held at Frank Mitchell and Associates to finalize the concept (optical and mechanical) for interfacing the optical modules with each other and with the optical bench mainframe.

B. OPTICS

1. A design review meeting was held at Alpha on 17 and 18 August, with Air Force attendance on the second day. Characteristics of the proposed common objective are summarized in figure 1.

2. Alpha's preliminary design for a three or four element zoom lens for the lead vapor illuminator insertion is particularly

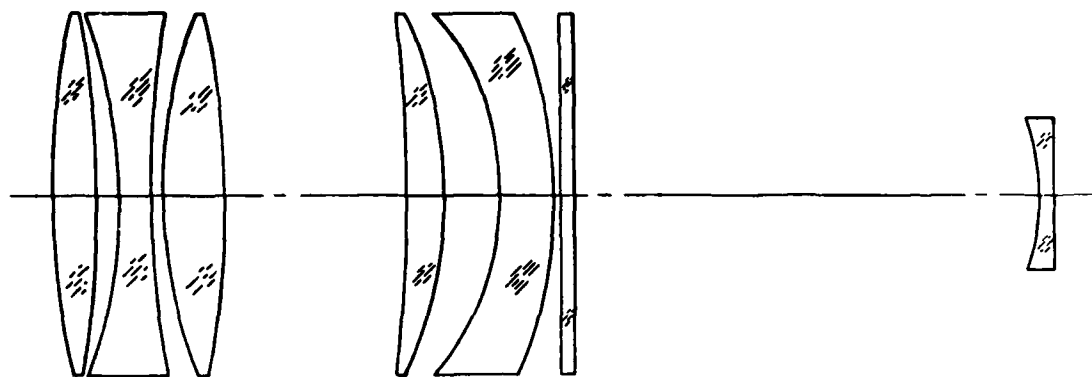

Figure 1. CATIES Common Objective (Prototype, 8-23-78)

attractive now; it has fewer elements than the fixed-focal-length turret design, and presents no severe mechanical challenges. To meet the 4 watt output requirement (a prime consideration), a 1.5 inch diameter beam having 9 milliradians divergence should be anticipated. (This was determined from subsequent calls to SSL, Valley Forge, Pa., and these numbers are still subject to change.) The zoom approach is versatile enough to accommodate changes, as adjustable mechanical stops can be implemented to obtain desired magnifications while still proving reasonable far field uniformity. For further discussion of the lead vapor illuminator, refer to paragraph F.

3. Alpha was asked to supply more information about the proposed zoom lens approach. The afocal anamorphic telescope will not be considered at this time, because the additional complexity and cost of the optical design, alignment requirements, and derotation assembly cannot be justified. Effects on far-field uniformity are not known right now. The sizes, spacing, and required movement for the zoom telescope were given for planning purposes. Alpha's final design will probably require a doublet on the input end to provide the necessary uniformity and the desired 5.5 to 1 magnification range (9 millirad to ≈ 8 millirad).

4. Performance data and other information supplied by Alpha were sent to consultant Don Kienholz. The proposed prescription for the common objective was also transferred, for independent analysis. Ray fan data for the narrow field of view appears in figure 2, and

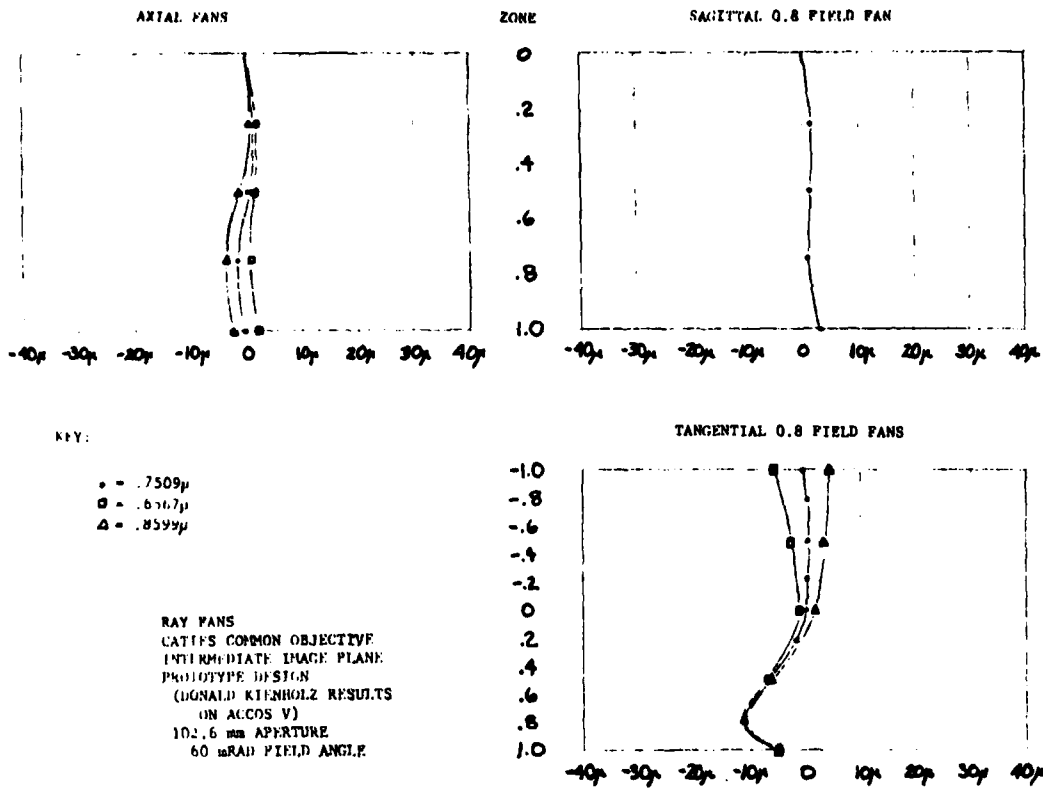
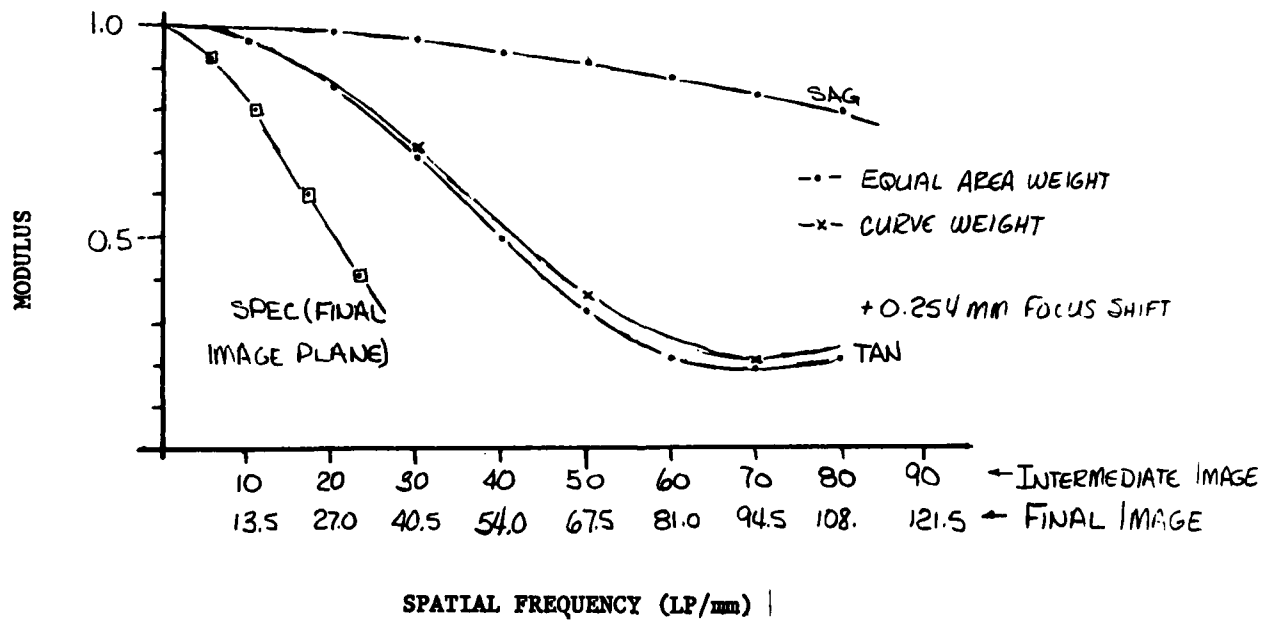
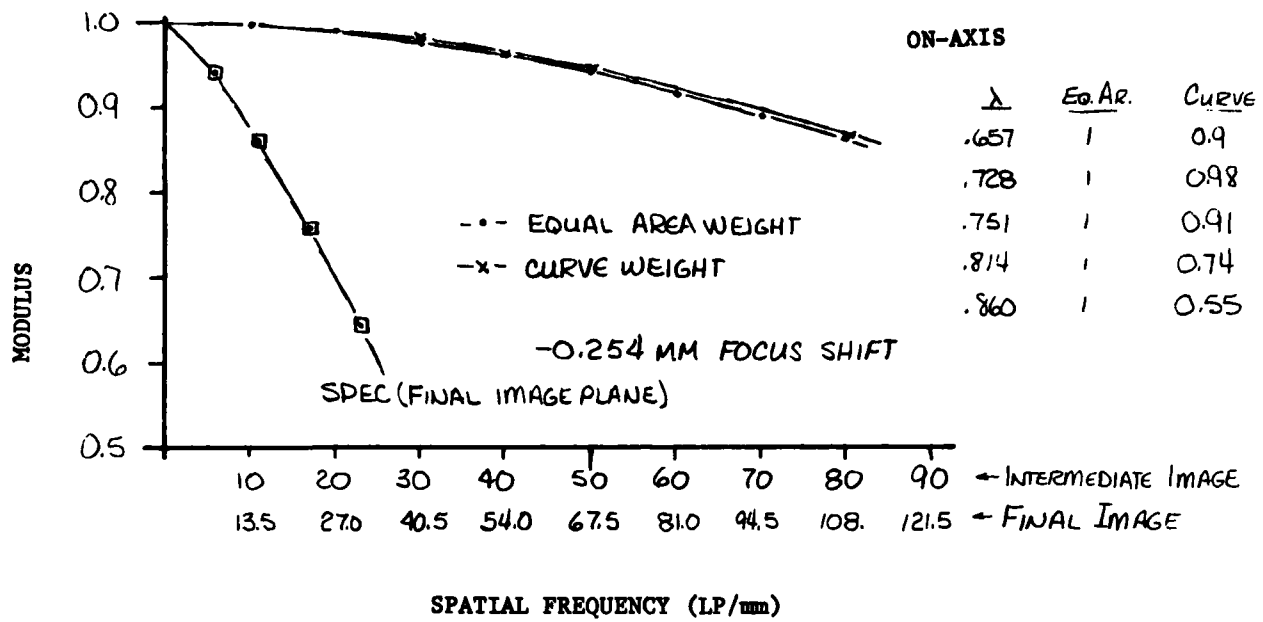

Figure 2. Ray Fan Plots (NFOV)

the following pertinent information was also provided:

- a. Very little performance difference exhibited by design when "equal area" or "points along curve" technique is used to select design wavelengths (see figure 3).
 - b. Overcorrection present at 0.8 of field is good for relay design.
 - c. Relay design appears to be feasible.
 - d. Some astigmatism present at 0.8 field.
 - e. On-axis OPD $\approx 0.1 \lambda$.
 - f. LGSK-2 is sensitive to thermal shock, per the Schott catalog. (This glass type was used, in similar size, on a Surface Navy LLLTV. The lens has been in the field for over a year.)
 - g. KZFS-5 has a different index of refraction in ACCOS and GREY programs.
5. Additional wide-field-of-view performance data supplied by Alpha during the evaluation/hold period appears in figure 4.
6. Although incomplete, the design for the common objective seems to be excellent. Accordingly, on August 30th, Alpha was told to proceed with the next phase of the program, and to complete the objective and relay design.
7. The optical filters for the filter wheel were sent out for coating, but as yet have not been returned.
8. The pointing mirror was sent out for coating. Two aluminum coatings were applied to prevent possibility of local heating due to pinholing. A magnesium oxide overcoat is used to provide maximum reflectance at TV and IR wavelengths. (A dip to 87% reflectance near 8 microns, typical for silicon monoxide coatings, does not occur with magnesium oxide.)



NOTE: DOES NOT INCLUDE
DIFFRACTION EFFECTS.

Figure 3. Geometric MTF for Prototype Objective

TANU=.100 YI=15.49 FLAT FIELD

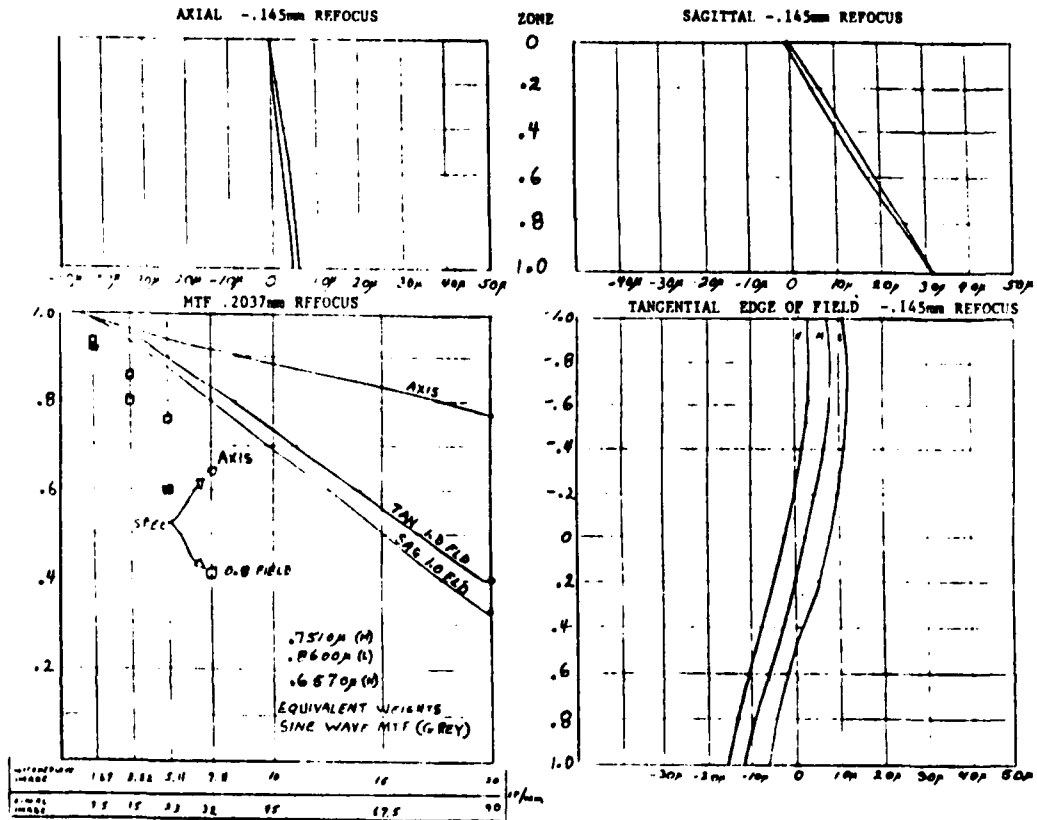

NOTES:

1. FANS ARE CONSTANT REFOCUS
DOES NOT HAVE FIELD CURVE
2. MTF IS AT GREY REFOCUS CONDITION
CONSTANT FOR ON/OFF AXIS

Figure 4. CATIES Wide Field of View (Objective Only)

C. MECHANICAL

1. On August 31st, a meeting was held at Frank Mitchell and Associates, in Pasadena, California. Its purpose was to finalize the CATIES opto-mechanical concept, incorporating all changes introduced to date. Enough information was obtained to allow the preparation of detailed drawings for the TV relay turret assembly and the optical assembly mounts.
2. The tape transport/shutter/filter assembly has been assembled and operated. The TV camera derotation/focus assembly has been fabricated. The housing for the spectral separator is complete, but will not be painted until details for adjusting and supporting the optical element have been determined and implemented.
3. The interface-electronics box (dip-brazed assembly) has been fabricated, and only requires painting by the model shop.
4. All three control panels have been painted and labeled, and are ready for wiring into the console.
5. The zinc-selenide element for the boresight assembly has been ground and polished, and is ready for edging.

D. ELECTRICAL

1. Both sync generator boards are complete and have been tested with the camera.
2. System cabling is complete, with the exception of four connectors that have not yet been received. This includes the cable and harness required to operate the TIS in the CATIES configuration.

3. Console wiring is underway. Circuit breakers and input power connectors, with associated wiring, have been installed.

E. MEETINGS

Three meetings were held during this report period (see figure 5).

F. MISCELLANEOUS

1. Increase of lead vapor illuminator beam diameter to 1.5 inches (and divergence to 9 milliradians) requires a change in the method for inserting the beam into the optical path. The reflective element cemented to the first element of the common objective may become larger by some, yet undetermined, value. It has become desirable to shorten the length of the raw beam path from illuminator to zoom telescope. A single turning mirror is being considered, and SSL has been asked to offset the output beam from the center of the housing to a position closer to the CATIES common objective.

2. For logistic purposes, the optical bench mainframe assembly will be made portable. The unit has evolved into a much heavier package than originally envisioned. The mainframe has been made extremely rigid to eliminate defocusing and boresight errors that could be caused by uneven loading; the lead vapor illuminator will require additional support structure; several electronic modules have been attached to simplify cabling and eliminate grounding problems. With Air Force concurrence, GE will add a base with casters to the mainframe to transport this assembly to various

ATTENDEES

<u>DATE AND PLACE</u>	<u>GE/AESD</u>	<u>OTHERS</u>	<u>MAIN PURPOSE</u>
17,18 August 1978 GE, Utica, NY Cazenovia Test Site	D. Pultorak J. Juliano M. Kolesa P. Tracy C. Frey	J. Stewart (AF)	View Progress of Hardware Development for CATIES System
23,24 August 1978 Alpha Optical Company Ocean Springs, MS	D. Pultorak J. Juliano M. Kolesa P. Wing	J. Stewart (AF) W. Martin (AF) G. Martin J. Hanlan R. Weaver J. Fahnestock	Review Alpha's Analysis of CATIES Baseline Optical Design, and Discuss Alpha's Recommend- ations for Improvement
31 August 1978 Frank Mitchell and Associates Pasadena, CA	M. Kolesa	F. Mitchell	Review Completed Modular Mechanical Concept and Bench Interface

Figure 5. Meeting Summary for August 1978
Report Period

test locations. A jack/leveling scheme will be used to lift the entire assembly off the casters when the system is to be operated. Based on tower requirements, the Air Force has stipulated a height of 55 inches (from floor to bottom of pointing mirror) for the assembly mounted on the detachable base.

3. Arrangements have been made to provide for a portable 1.75 kW, 400 Hz, 3 phase generator at the Cazenovia test site, to support CATIES testing.

COMMON APERTURE TECHNIQUES

FOR

IMAGING ELECTRO-OPTICAL SENSORS (CATIES)

R&D STATUS REPORT NO. 24

I. GENERAL

This twenty-fourth R&D Status Report describes the activities of GE/AESD in developing a Common Aperture Techniques for Imaging Electro-Optical Sensors (CATIES) Program under Contract F33615-76-C-1135, Item No. 0002, CDRL Sequence 2.

II. TECHNICAL

A. SUMMARY

1. Wiring and assembly tasks were continued throughout the report period. The remote control console and interface electronics unit is approximately 95% complete.
2. The azimuth drive assembly has been operated, and piece-parts for the boresight assembly are complete. Final assembly and testing will proceed when the coated optics are received by GE.
3. The intermediate design review with Alpha Optics was held at GE/AESD, Utica. The Air Force participated in this meeting, which was primarily set-up to review progress to date, and to

resolve opto-mechanical interface problems. A separate meeting was held with Air Force personnel the following day to review the total CATIES program schedule.

4. A meeting with Frank Mitchell Associates, Pasadena, California, which took place on 31 August 1978, established an opto-mechanical interface. Appendix A of Status Report No. 24 contains a trip report for this meeting.

B. OPTICS

1. An Intermediate Design Review with Alpha Air Force and AESD personnel was held in Utica on 25 and 26 September. The primary purpose for this review was to work out mechanical details for the optics; a secondary purpose was to review the optical design status.

2. No serious mechanical interface problems were encountered. A change in the relay cell mounting was established to simplify focus and alignment at test and assembly stages. The change involves having an inner sleeve containing all of the elements moving via adjustment screws within an outer sleeve which mounts on the relay turret. Alpha will align the elements in the inner sleeve and provide adjustment capability with respect to the outer sleeve. During final assembly and test the three relays will be made confocal at the appropriate distance.

3. A review of the MTF for each path is shown in Appendix B. Without considering manufacturing tolerances, the wide and narrow field of view are comfortably above the minimum MTF specs, but the very narrow field of view is only marginally set. Prior to any further optimization, Alpha will evaluate the existing design with an RG-665 filter and the night camera instead of the original design objective of using an RG-630 filter with the night camera. These results will be discussed in next month's report.

4. Preliminary assessments on the manufacturability of the Alpha design indicate that the design is sensitive, but can be built. Index sensitivity will require a melt optimization with the radii on one or two elements being used to offset index of refraction changes from nominal values.

5. The zoom illuminator optics preliminary design is complete. A 5.5:1 zoom range has been achieved with edge rolloff very good (<1 milliradian) at the 1.33:1 zoom point and adequate (<2 milliradians) at the 5.33:1 zoom point. The zoom optics contain five elements with two moveable air-spaced doublets for accomplishing the zoom function.

6. The WFOV relay lens design offered a back-focus distance of approximately 1.3 inches. The minimum clearnace required for focus-derotation and filter wheel - ALC mount is 1.51 inches. Figure 1 shows a modified relay lens design that will provide 1.75 inches of back focus distance.



OVERALL LENGTH: 14.53 INCHES
BACK FOCUS: 1.75 INCHES

SCALE: $\frac{1}{2}$

Figure 1. CATIES WFOV Relay Plus Field Lenses

7. Alpha Optics placed an order for glass (common objective) with Shott Optical Company on 15 September. It is hoped that an earlier order placed by Alpha for another requirement will be adequate for CATIES needs. This information will not be available until the next report period.

8. At the design review, considerable discussion about the scan mirror and spectral separator impact on optical performance resulted in several action items. Alpha will evaluate the mirror and separator from an overall optical performance standpoint, and AESD will investigate possible testing of the mirror and separator in their mountings.

C. MECHANICAL

1. Detailed drawings for the spectral separator mounting have been completed and released to the Model Shop for fabrication.

2. All parts for the azimuth drive assembly have been received. (This portion of the system has been operated in the laboratory.)

3. An effort is now underway to establish an optical interface mount that will, essentially, tie the major optical assemblies (i.e., objective, relay turret, zoom lens) to a common reference.

4. Fixtures for the optical portion and mechanical piece parts of the boresight spot assembly are complete. The optical elements have been cut to proper dimensions, and have been polished.

D. ELECTRICAL

1. Interface electronics unit wiring is complete. The unit will be tested, with boards in place, when the console, system cables, and motor drives are completely assembled.

2. The remote control console is nearly complete. Power and control panels have been wired and bench tested. Some components (e.g., Conrac monitor slides, potentiometer range controls, knobs) have not yet been received.

3. Electrical modifications to the silicon Vidicon camera electronics unit are nearly complete. Final assembly of the head has been deferred until machined parts are released from the Model Shop.

E. MEETINGS

Two meetings, summarized in Figure 2, were held during this report period.

ATTENDEES

<u>DATE AND PLACE</u>	<u>GE/AESD</u>	<u>OTHERS</u>	<u>MAIN PURPOSE</u>
25, 26 September 1978 GE, Utica, NY	D. Pultorak J. Juliano M. Kolesa C. Frey P. Wing	J. Stewart (AF) W. Martin (AF) J. Fahnestock (Alpha) G. Martin (Alpha) R. Weaver (Alpha)	Optics Control Phase I Design Review
27 September 1978 GE, Utica, NY	D. Pultorak C. Frey P. Tracy	J. Stewart W. Martin	CATIES Schedule Review

Figure 2. Meeting Summary for September 1978 Report Period

APPENDIX A TO R&D STATUS REPORT NO. 24

TRIP REPORT

13 Sept. 1978

Traveler: Mike Kolesa
Place Visited: Frank Mitchell Associates, So. Pasadena, Ca.
Date of Visit: August 31, 1978
Object of Visit: Preliminary Design Review of Mechanical
Concept for CATIES Optical System

The effort at Frank Mitchell Associates was reviewed and found to be consistent with the objectives of the statement of work, and progressing at a proper rate. Conceptually the design is approximately 70% complete with about 50% documented. It should be mentioned that the design effort is based on the base line configuration until better information is available from the present optical vendor. It is felt, however, that generally since only concept is being addressed, that the effort will be adaptable, barring any major optical design changes.

Concepts have been worked out for all the optical system elements, with refinements now in process. A common objective lens outline and relay lens outline are being generated and will be available on Sept. 8th. A concept has been worked out for a 2 position illuminator turret, but will be shelved since the present optical vendor is proposing a zoom lens configuration. Preliminary zoom lens mechanical criteria from the optical vendor was given to Frank Mitchell. A relay turret drive has been worked out and will be refined and detailed.

The only problems encountered have been the ambiguity, incompleteness and conflicting base line design information.

Mike Kolesa
Mike Kolesa
Sr. Engineer
Extension 5368
M.D. 908

/jip

COMMON APERTURE TECHNIQUES
FOR
IMAGING ELECTRO-OPTICAL SENSORS (CATIES)
R&D STATUS REPORT NO. 25

I. GENERAL

This twenty-fifth R&D Status Report describes the activities of GE/AESD in developing a Common Aperture Techniques for Imaging Electro-Optical Sensors (CATIES) Program under Contract F33615-76-C-1135, Item No. 0002, CDRL Sequence 2.

II. TECHNICAL

A. SUMMARY

1. The Critical Design Review (CDR) for the optical assemblies was held at Alpha Optical Company on 25 and 26 October. Delivery and limited availability of the raw glass still present problems that may have an impact on the overall program schedule. Many opto-mechanical interface details, however, were resolved at these sessions, and enough information was obtained by GE to allow finalizing work being done with Frank Mitchell Associates.
2. The spectral separator order has been placed with Valtec Company, Holliston, Massachusetts. Test and delivery of the coated substrates is expected shortly after the first of next year.
3. A relay turret concept drawing has been provided by Frank Mitchell Associates. GE is preparing detailed drawings to allow fabrication by the model shop. A change to this assembly is required for compatibility with the 1.70-inch back focal length (BFL)

in air, of the WFOV relay designed by Alpha. The original turret concept was configured about a 2.122-inch BFL, established in the baseline design, but overlooked by Alpha in its design effort.

4. A spectral separator mount, which supports and allows precise adjustment of this critical element, has been designed and fabricated.

5. Work is nearly complete on the control console and boresight assembly. Installation of terminal strips, and wiring of the sensor optical mainframe is almost completed.

6. The day camera head was assembled and operated. Picture quality is excellent; center resolution of 800 TV lines per picture height was obtained with this sensor. Assembly of the intensifier module for the night camera is underway and , barring unforeseen problems, will be completed within the next two weeks.

7. A single sketch, indicating overall dimensions of the lead vapor illuminator, has been received to date. It is our understanding that fabrication and assembly of the illuminator was to be complete by the end of October. (The month of November was reserved for testing at SSL.) it is necessary to have an accurate, detailed, mechanical drawing with dimensions, by 15 November, to minimize risk and to aid design of the support assembly.

B. OPTICS

1. The critical design, held in Ocean Springs, Mississippi, was attended by the Air Force on 26 October. The first day's meeting was used primarily to review the mechanical interface drawings, to ensure that the optical assemblies fabricated by Alpha will conform to the outline drawings developed from baseline design and prepared by GE prior to the IMDR. Besides the shortened WFOV relay BFL, several minor discrepancies in dimensions and tolerances were discussed, to arrive at mutually acceptable solutions. At the conclusion of this session, it appeared that all areas of concern had been satisfactorily explained or resolved.
2. The second day's meeting centered on reviewing performance of the completed optical design. Significant improvements in MTF and color have been realized since the Intermediate Design Review (refer to Appendix A). The MTF data shown for the NFOV and VNFOV do not take into account the effects of the obscuration introduced by the lead vapor insertion mirror. The tolerance analysis was reviewed to indicate how data would be used for fabricating and aligning the optical system.
3. Considerable information is yet to be provided by Alpha before the design can be considered complete. A description of these items (specifically tasks 2 through 9) and their current delivery dates are summarized in CDR Action Item List, Figure 1.
4. Alpha will guarantee MTF performance at the 70-percent level of paper design values, and will treat the 85-percent values as a design goal. Figure 2 shows (for a specific spatial frequency

<u>Item</u>	<u>Due Date</u>	<u>Responsibility</u>
1. Status of Raw Glass in Transit from Schott	Continuing	Alpha
2. Update Element Drawings	1 December	Alpha
3. Index Shift Study	15 November	Alpha
4. Narration on Thermal Sensitivity	15 November	Alpha
5. Complete Zoom Illuminator (Including Drawings and Tolerances)	10 November	Alpha
6. Investigate Coating Specification and Its Applicability to This Design; Make Recommendations	1 December	Alpha
7. Tabulate Interface Mounting Tolerances on All Major Subassemblies	3 November	Alpha
8. Detailed Mechanical Drawings Including LV Insertion Mirror	15 December	Alpha
9. Review Specification; Comment to GE	3 November	Alpha
10. Review Outline Drawings	3-10 November	GE
11. Update SOW and Specification to Reflect Zoom Illuminator	3 November	GE
12. Investigate MTF Test Collimator	30 December	Alpha

Figure 1. CDR Action Item List

<u>FOV</u>	<u>Percent</u>		
	<u>Wide</u>	<u>Narrow</u>	<u>Very Narrow</u>
Specified On Axis MTF	64	64	64
Paper Design (Ignoring Obscuration)	76	76	74
Predicted MTF (With Obscuration)	76	≈76	72/69*
Predicted (85 percent)	65	65	61/59*
Predicted (70 percent)	53	53	50/48*

*MTF varies with direction of scan (obscuration located at 9 o'clock, looking into common objective from front).

Figure 2. MTF Performance (Percent at 32lp/mm)

on-axis) the effect of the obscuration on each field of view, and the MTF goal and guarantee levels compared with the optical specification values. Alpha also indicated that veiling glare in the VNFOV would be higher than the two percent specified, and could be as high as eight percent. With Alpha's best effort, it is expected that the value measured during the final acceptance test will be somewhere between these two values.

5. At the CDR, Alpha still projected a zero-to-four week schedule slippage (even assuming that all goes well with the glass order). Alpha indicated that it is considering several options and shortcuts that could permit meeting the desired delivery dates (FW4 for zoom optics, FW10 for TV paths) including purchase of test glasses from outside vendors.

6. In a telephone call to GE on 31 October, Alpha supplied the following information: Four blocks of high-index glass have been received by Shott, in Pennsylvania. Of the four blocks, only one was polished; straiie was Grade-B rather than the Grade-A ordered. The quality of the remaining pieces is unknown. The shipment did not contain enough glass for two complete sets of optics, but more than enough for one complete set. If any of the remaining glass is of higher quality, it will be used in the common objective. The higher straiie content could lower MTF by three to five points, and increase veiling glare. The zero-to-four week possible schedule slippage originally predicted now looks like four weeks, because of this -- but it could change. Alpha has directed Shott

to cut and evaluate the rest of the glass (a process that will take 7 to 10 days), and is in daily telephone contact with them.

7. The purchase order for the spectral separator (fabrication and coating) was placed with Valtec on 23 October. Delivery is promised by 19 January 1979. In terms of performance, the only exception taken to baseline design optical element drawing No. PE660-4539 is to Note 5 (R2 will have 96 percent transmission minimum, with an average of 97 percent; a design goal of 98 percent will be accepted). All reflectance and transmission measurements will be made on witness samples 1.5 inches in diameter and 0.984 inches thick, polished to $\lambda/4$, parallel to 30 seconds.

8. All boresight spot assembly elements have been fabricated at GE, and sent to a vendor for coating.

C. MECHANICAL

1. All parts of the spectral separator mount have been received from the model shop, and are ready for final assembly.

2. The mechanical consultant (Frank Mitchell Associates) has completed a turret concept, and is now finalizing drawings for the other major assemblies. GE is preparing detailed drawings for fabrication, and is also ensuring that the Alpha design is compatible.

3. A detailed drawing for the joystick control is nearing completion. All necessary parts are available, and assembly of this panel will allow the control console electrical wiring to be completed.

4. The silicon vidicon camera head has been assembled, and the night camera intensifier module is nearing completion. Piece-parts for installing the interchangeable camera heads in the focus/derotation mount are complete and have been tested for proper fit.

5. Both camera monitor console adapter kits have been received and installed in the control console. These kits have been tested for compatibility with RQA-14 and RQB-14 monitors.

6. Brackets for connectors and terminal strips have been mounted on the optical bench mainframe. Wiring to the pointing mirror assembly has been routed and clamped in a manner that minimizes risk of wire beakage caused by slewing in azimuth and elevation.

D. ELECTRICAL

1. The silicon camera, operated in the laboratory, has exhibited an 800 TVL limiting center resolution. The unintensified night camera was operated, and exhibited center resolution greater than 1000 TVL per picture height. High Voltage Power Supplies are now being wired into the intensifier module.

2. An estimated 95 percent of all electrical wiring tasks are completed. Power is being applied to portions of the system to check operation of various subassemblies.

3. One of the two critical missing connectors was air-mailed to GE on 30 October; representatives are at the Deutsch Plant to arrange for the shipment of the remaining connector (or at least the insert) by 3 November.

4. A quotation for a third generation hybrid power supply has been received from Galileo Electro-Optics Corporation. Outline

drawings, for the three unit modular device compatible with the CATIES configuration were also received. Figure 3 lists major electrical characteristics of this power supply.

E. MEETINGS

Two meetings, summarized in Figure 4, were held during this report period.

Attendees

<u>Date and Place</u>	<u>GE/AESD</u>	<u>Other</u>	<u>Main Purpose</u>
13 October 1978 WPAFB, Ohio	D. Pultorak C. Frey	J. Stewart	Review CATIES Manpower Runout
25, 26 October 1978 Ocean Springs, Mississippi	D. Pultorak C. Frey M. Kolesa J. Antonelli P. Wing	J. Stewart W. Martin J. Fahnestock G. Martin R. Weaver	CATIES Optics - Critical Design Review

Figure 4. Meeting Summary for October 1978 Report Period

COMMON APERTURE TECHNIQUES
FOR
IMAGING ELECTRO-OPTICAL SENSORS (CATIES)
R&D STATUS REPORT NO. 26

I. GENERAL

This twenty-sixth R & D Status Report describes the activities of GE/AESD in developing a Common Aperture Techniques for Imaging Electro-Optical Sensors (CATIES) Program under Contract F33615-76-C-1135, Item No. 0002, CDRL Sequence 2.

II. TECHNICAL

A. SUMMARY

1. Most of the optical design data described in the CDR Action Item List (see last month's report) has been received from Alpha Optical Company. Additional delays for optical assembly delivery have been projected; these are discussed in detail in the report.
2. A trip was made to WPAFB to witness operation of the Honeywell Thermal Imaging Sensor (TIS) and verify that fabricated cables for CATIES are compatible with this Government Furnished Equipment. The TIS was shipped to GE via Griffiss AFB, and was transferred to the laboratory on 30 November.
3. Delivery of the lead vapor illuminator has been delayed until the first of the year. Space Science Laboratories will modify the laser head assembly to facilitate integration into the CATIES system. This work should preclude further delay in in-house activities, once the laser is received.

4. Valtec will have the spectral separator ready for coating by December, and will ship it to GE before the end of the year.
5. All drawings from Frank Mitchell and Associates have been received; detailed drawings are now being prepared (specifically, the relay turret, zoom lens for lead vapor illuminator insertion, and transfer housing mechanical assemblies).
6. A concept for supporting the lead vapor illuminator head has been evolved. A shutter assembly for this housing has been detailed, and a motor driven hydraulic lift (to raise and lower the entire CATIES system) has been purchased. The lift is mounted on wheels, and can be transported.
7. Pointing mirror circuitry for both azimuth and elevation has been tested and successfully operated with the fabricated joystick assembly. Efforts are now in progress to obtain proper LED display readouts in the control console.
8. The night TV camera and intensifier were operated, but significant electromagnetic interference (EMI) problems were encountered. Additional shielding of the intensifier package and decoupling of the input voltages eliminated radiation problems when the camera was operated in the gated mode. Passive mode operation, however, was still unacceptable. Discussions with Galileo resulted in a determination of the source, and a design change that should eliminate this problem. A modified supply has been shipped to GE, and will be wired-in and tested as soon as it is received.
9. Delays associated with delivery of various sensors and optics have caused GE to slow down in-house activities (and associated

manpower charges). At present, only one draftsman and one technician are applied full time to the CATIES program. In the future, specific technician tasks will be assigned as parts and equipment become available. This mode of operation is expected to continue at least until the optical assemblies are received.

B. OPTICS.

1. Appendix A of R&D Status Report No. 26 is a copy of the CDR minutes prepared by Alpha Optical Company. Only some of the listed attachments have been included, as final melt data and test glass data optimizations are yet to be preformed.
2. Appendix B of R&D Status Report No. 26 is a tabulation of interface mounting tolerances for all major subassemblies (action item 7), and a narrative discussion of thermal sensitivity (action item 4).
3. Appendix C of R&D Status Report No. 26 contains recommendations for changes to optical element coatings, based on manufacturers' data (action item 6).
4. Figure 1 is the most recent Alpha Optical milestone chart available. End item delivery for TV-related optics was extended to week 13 of 1979, because of problems (which now appear to be resolved) associated with delivery of the raw glass. Milestones 8,10,19,20 have been passed on schedule.
5. Schott has completed tests of the raw glass, and has determined that there is enough for two sets of relay blanks and "1 1/2 sets" of objective glass blanks. Straie quality is Grade A where requested. Melt designations were made for index sensitive parts that allow optimizing optical design to test glasses.

6. On the 76 optical surfaces in CATIES that require test glasses, about half the number of these glasses now needed will be eliminated by design optimization. Total manufacturing time has been shortened from 16 weeks (because of raw glass problems) to 11 weeks. To meet scheduled delivery, Alpha will subcontract selected tooling and components.

7. Figure 1 indicates that the zoom optics would not be completed until week 10 of 1979. Subsequent telephone calls revealed that most of the six-week slip was projected, because of Alpha's assumption that detailed element cell or housing drawings would not be received from GE before the end of the year. Upon receipt of this information, GE co-ordinated the task with Frank Mitchell Associates, and detailed drawings were mailed to Alpha on 30 November. This action should recover at least four weeks of the six week slip.

C. MECHANICAL

1. A concept for mounting and supporting the lead vapor illuminator head has been evolved. SSL, Valley Forge will implement some of the modifications to this unit, to make it compatible with the rest of the CATIES system. The delay (from 1 December) in shipping this unit is caused by late delivery of an air-cooled thyratron (now expected by 30 November).

2. Detailing of the turret assembly and transfer housing is now in progress; drawings will be released to the model shop, for fabrication, during the next report period.

3. An order has been placed for a South worth hydraulic lift. The lift has a 48-inch vertical travel, and a collapsed height of

approximately 8 inches. Lift capacity is 2000-pounds. The table (mounting surface) is very stable, and is 36-inches wide by 90-inches long. Promised delivery date for this unit is 4 January 1979.

4. All critical connectors have finally been received, and have been installed in the system. The joystick control box and panel assembly have been fabricated, wired into the system, and tested. A problem (i.e., unable to obtain smooth operation in one direction) with the azimuth motor gearhead was detected, and the assembly had to be returned for rework.

D. ELECTRICAL.

1. The silicon vidicon camera has been operated in the CATIES configuration with remote horizontal and vertical sweep-centering controls.
2. Electrical test and debug of the filter wheel/shutter/tape transport and the focus/derotation circuitry is complete, and schematic diagrams have been updated.
3. Azimuth and elevation drive circuits are operational, and work is progressing on the light-emitting diode (LED) readout display.
4. The gating supply has been removed from the intensifier module, and returned to Galileo for replacement. This change is expected to cleanup the EMI problem in the intensified ATV camera. The gating unit was shipped to GE on 27 November, and will be reinstalled and tested upon receipt.

E. MEETINGS

One meeting (on 16 November) was held, in Dayton, Ohio, to witness operation of the Honeywell FLIR to be incorporated into the CATIES System.

APPENDIX A TO R&D STATUS REPORT NO. 26

(13 pages)

MINUTES

CATIES FINAL DESIGN REVIEW
GE/AESD P.O. #F12-7F-02646
S.O.W. TASK 8 (3.8.3)
HELD AT ALPHA 26 OCTOBER 1978

ATTENDEES:

John M. Fahnestock, Jr.
Richard R. Weaver
Gay G. Martin
Peter H. Wing
Cliff O. Frey
Dan Pultorak
Mike Kolesa
Joe Antonelli
Bill Martin
Jim Stewart

President, Alpha Optical Systems
Chief Engineer, Alpha Optical
Sales Manager, Alpha Optical
Senior Buyer, GE AESD
Program Manager, GE AESD
Program Engineer, GE AESD
Engineer, GE AESD
Optical Specialist, GE AESD
Optical Engineer, USAF
CATIES Project Engineer, USAF

SUBMITTED BY:

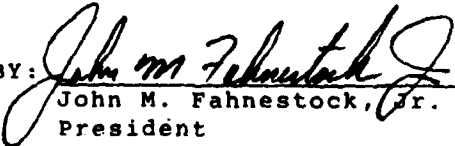
John M. Fahnestock, Jr.
President
ALPHA OPTICAL SYSTEMS, INC.

1. Optical design is complete except for final optimization to melt data and test glasses. Performance was demonstrated by presentation of fans and MTF curves. Diffraction effects of the lead vapor laser insertion mirror obscuration were considered. The design was acceptable to both GE and the Air Force, and authorization was made to proceed with its manufacture. Alpha proposed an MTF performance goal of 85% of computer design (obscured) and a specification of 70% of computer design (obscured) or the baseline specification, whichever is lower. These numbers would apply to the MTF as measured on Alpha's MTF bench. After some discussion, Alpha's proposal was accepted by GE. MTF (design and spec) is tabulated in an attachment. Prescription, fans, MTF curves, and schematic drawings are also attached.
2. The LDR focus lens design as presented was accepted by GE. Prescription and sketch is attached. No further work by Alpha is required.
3. Layouts of the mechanical design were presented. GE will advise Alpha of any required changes or recommendations. Alpha will advise GE of interface tolerance requirements.
4. It was agreed that GE will design the zoom illuminator lens housings and Alpha will manufacture and assemble. Alpha will provide GE with lens mounting information.
5. System delivery was discussed. A 0 to 4 week slippage from week 10 of 1979 is projected due to problems associated with raw glass delivery. Alpha is monitoring and expediting this problem and will keep GE advised. (The glass problem has been detailed to GE in separate correspondence since the IMDR).

6. All official contract and technical communications will be made in writing through subcontracts GE (PHW), and program manager Alpha (JMF).

MTF AT 32 lp/mm

	WIDE FOV	NARROW FOV		VERY NARROW FOV	
<u>AXIS</u>		<u>TAN/SAG</u>		<u>TAN/SAG</u>	
Unobscured	.76	.78/.78		.74/.74	
Obscured	.76	.78/.76		.72/.69	
.85 x Pred. (obscured)	.65	.66/.65		.61/.59	
.70 x Pred.(obscured)	.53	.55/.53		.50/.48	
Baseline Spec.	.64	.64		.64	
Proposed Spec.(obscured)	.53	.53		.48	
Performance Goal	.65	.65		.59	
<u>FIELD (0.8)</u>		V	H	V	H
Unobscured	.64/.72	TAN/SAG	TAN/SAG	TAN/SAG	TAN/SAG
Obscured	.64/.72	.77/.71	.74/.73	.62/.62	.67/.54
.85 x Pred.(obscured)	.54/.61	.65/.60	.63/.62	.53/.53	.57/.46
.70 x Pred.(obscured)	.45/.50	.54/.50	.52/.51	.43/.43	.47/.38
Baseline Spec.	.41	.41		.41	
Proposed Spec.(obscured)	.41	.41		.38	
Performance Goal	.54	.60		.46	

NOTES:

1. V denotes obscuration decentered vertically, or in line with field angle. H denotes obscuration decentration at right angles to field angle.
2. For reference, the VNFOV wavefront versus MTF at 32 lp/mm is approximately:

diffraction limit	.81	.5 wave	.58
.25 wave	.75	.625 wave	.47
.375 wave	.67	.75 wave	.36

3. Using a straight-line function for specification MTF plus the data in the above table, proposed MTF specification at other frequencies is:

SPATIAL FREQ. (lp/mm)	AXIS SPEC/GOAL			0.8 FIELD SPEC/GOAL		
	WFOV	NFOV	VNFV	WFOV	NFOV	VNFOV
7.5	89/92	89/92	88/90	86/89	86/91	85/87
15	78/84	78/84	76/81	72/78	72/81	71/75
23	66/75	66/75	63/71	58/67	58/71	55/61
32	53/65	53/65	48/59	41/54	41/60	38/46

ATTACHMENTS:

1. Action Items List
2. MTF Tabulation
3. Preliminary Optical Design Layouts
 - a. Objective SK1167011 (NR) 10/24/78
 - b. WFOV Relay SK1167012 (NR) 10/24/78
 - c. NFOV Relay SK 1167014 (NR) 10/24/78
 - d. VNFOV Relay SK 1167013 (NR) 10/24/78
4. Computer Prescriptions
 - a. Objective and WFOV relay
 - b. Objective and NFOV relay
 - c. Objective and VNFOV relay
 - d. LDR Transmitter
 - e. LDR Receiver
5. Viewgraph Copies
 - a. LDR focus lens
 - b. LDR transmitter angular output ray fan
 - c. WFOV TV Ray Fans
 - d. WFOV TV MTF
 - e. NFOV TV Ray Fans
 - f. NFOV TV MTF (obscured)
 - g. VNFOV TV Ray Fans
 - h. VNFOV TV MTF (obscured)
 - i. LDR Receiver Ray Fan

α

CATIES CDR 10/26/78

ACTION ITEMS:

- Alpha 1. Status of raw glass in transit from Schott.
- Alpha 2. Update element dwgs by 12/1.
- Alpha 3. Index shift study by 11/15.
- Alpha 4. Narration on thermal sensitivity by 11/15.
- Alpha 5. Complete zoom illuminator by 11/10. Includes dwgs & tolerances.
- Alpha 6. Investigate coating spec. and its applicability to this design and make recommendation by 12/1.
- Alpha 7. Tabulate interface mtg. tolerances on all major subassys by 11/3.
- Alpha 8. Detailed mechanical dwgs included LV insertion mirror 12/15.
- Alpha 9. Review spec. & comment to GE 11/3.
- GE 10. Review outline dwgs by 11/10 - 11/3.
- GE 11. Update S.O.W. and spec. to reflect zoom illuminator by 11/5.
- Alpha 12. Investigate MTF Test Collimator by 12/30.

$M = .7509 \mu\text{m}$
 $L = .8599 \mu\text{m}$
 $H = .6567 \mu\text{m}$

TANGENTIAL FIELD FANS



OCT 26 1978

CATIES WFOV
 RAY FAN PLOTS
 10-24-78

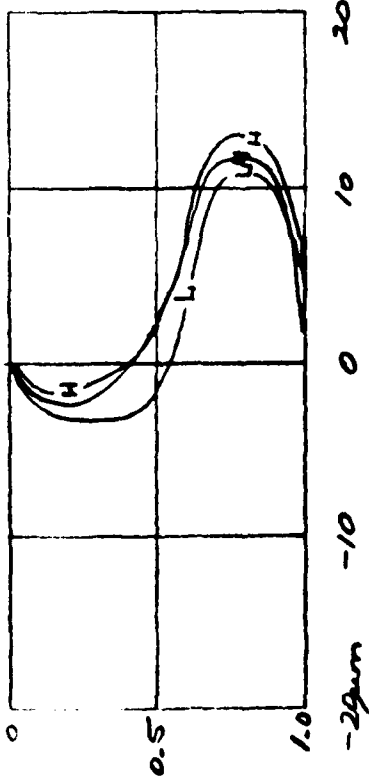

AXIAL FANS

REFOCUS $-.0528 \text{ mm}$

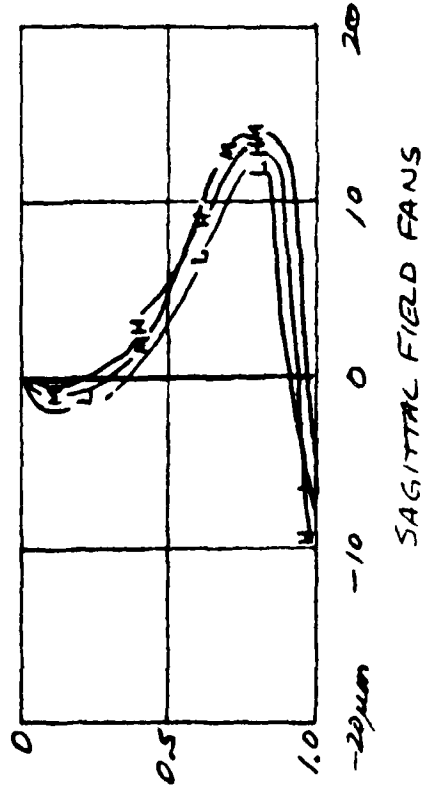

SAGITTAL FIELD FANS

OCT 26 1978

CATIES WFOV
SINE WAVE MTF
10-24-78

EQUAL WEIGHTING:
 $\lambda = 75 \mu\text{m}$
.860 μm
.657 μm
● AXIS
□ TAN 0.8 FLD
○ SAG 0.8 FLD
REFOCUS = -.1036 mm
⊙ = SPEC

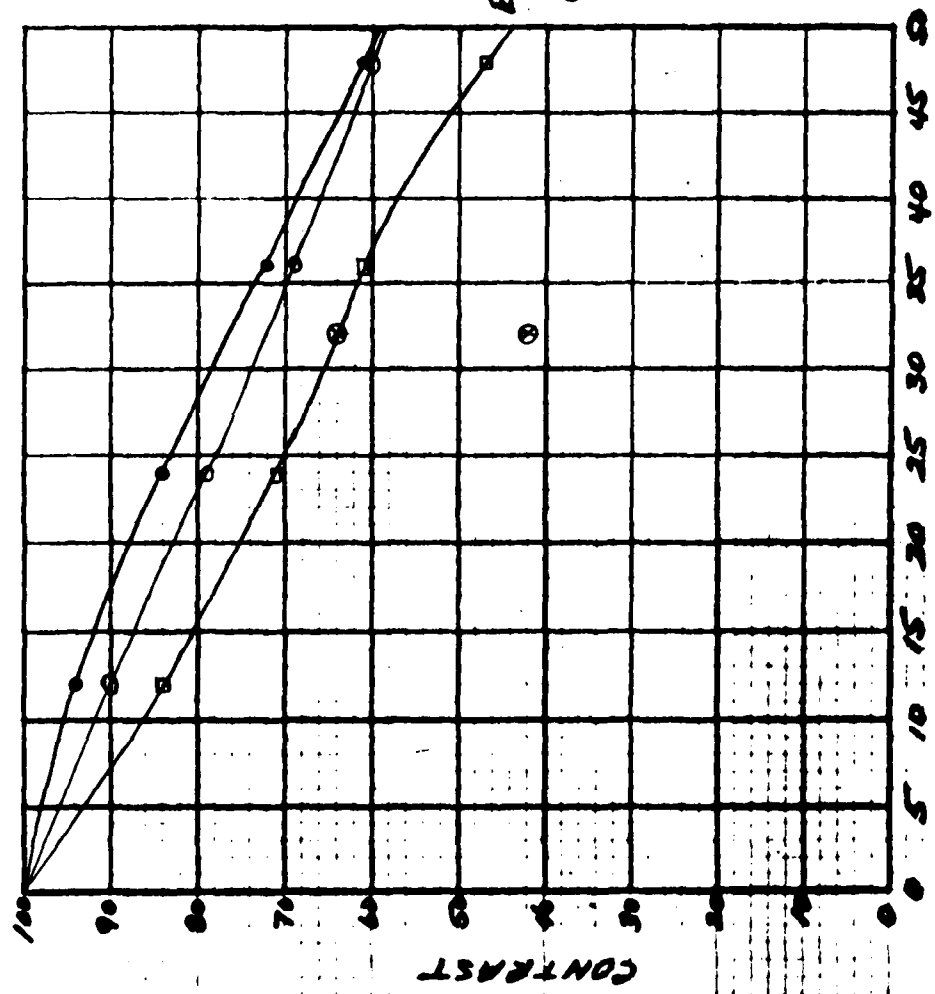

M = .7509 μm
 L = .8599 μm
 H = .6567 μm

TANGENTIAL FIELD FANS

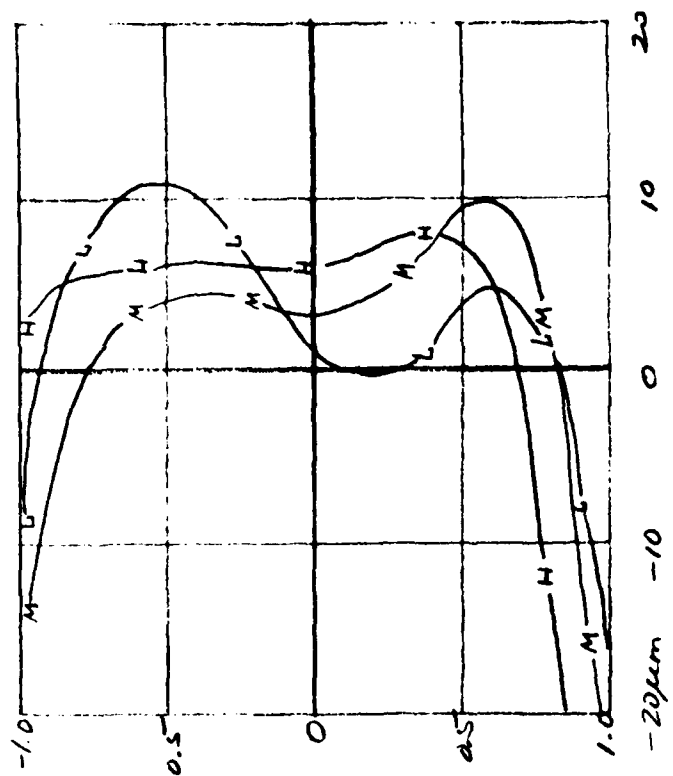

OCT 26 1978

CATIES NFOV
 RAY FAN PLOTS
 10-24-78

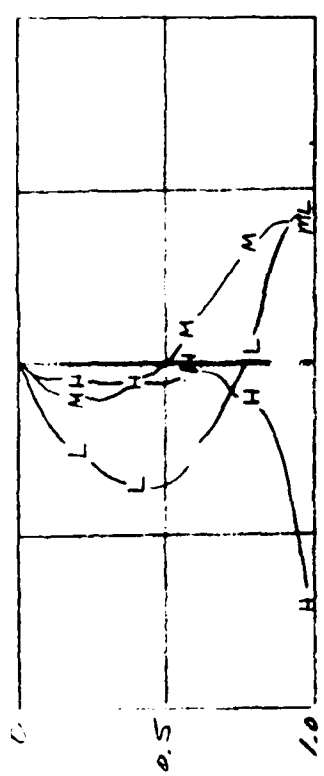

AXIAL FANS

REFOCUS ± 0.0025 mm

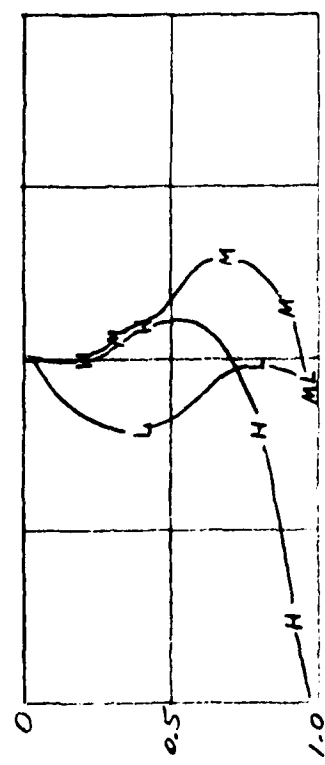

SAGITTAL FIELD FANS

OCT 26 1978

EQUAL WEIGHTING:

$\lambda = .75 \mu\text{m}$

.860 μm

.657 μm

● AXIS

□ TAN 0.8 FLD

○ SAG 0.8 FLD

REFOCUS = .0025 mm
WORST ORIENTATION
OF
DECENTERED OBSCURATION
(V)

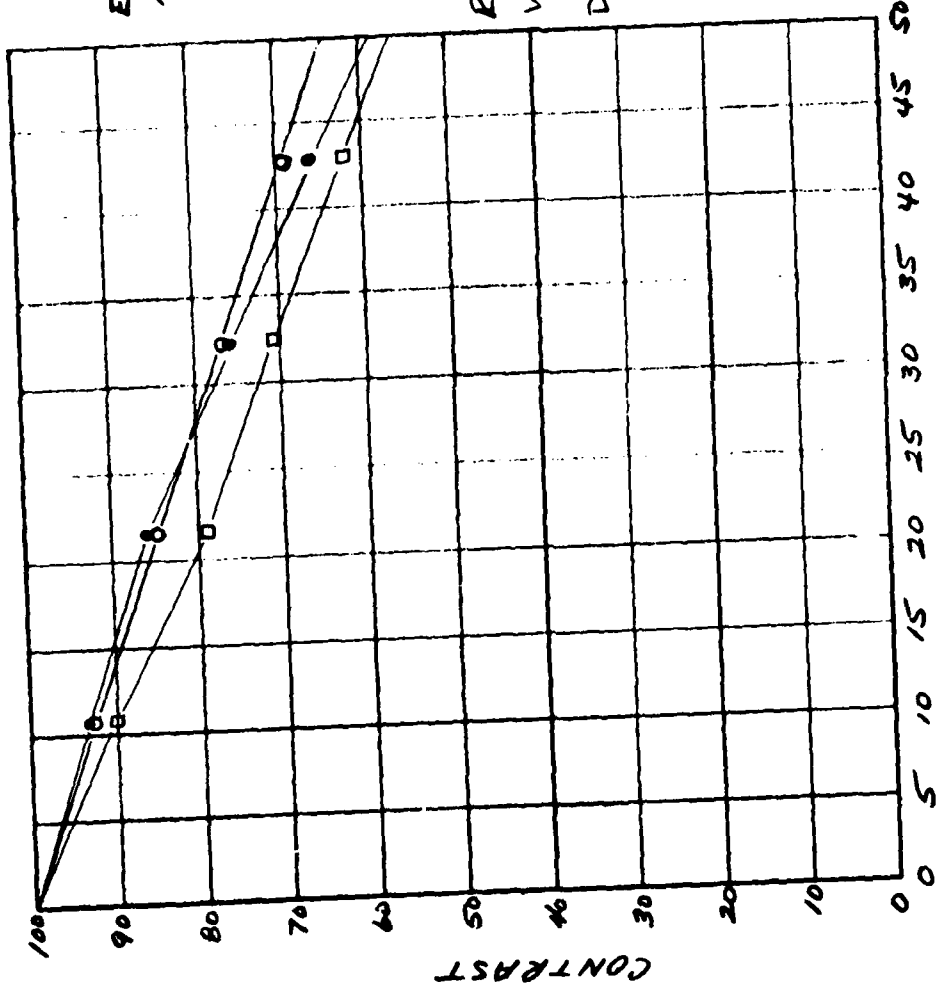

CATIES NFOV
OBSCURED
SINE WAVE MTF
10-27-78

$M = .7509 \mu\text{m}$
 $L = .8599 \mu\text{m}$
 $H = .6567 \mu\text{m}$

TANGENTIAL FIELD FANS

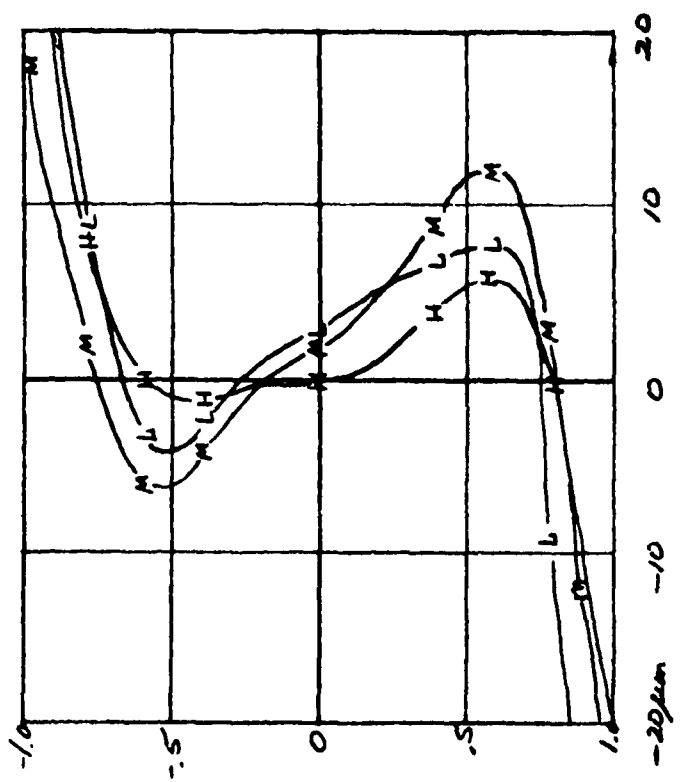

CATIES UNFOV
 RAY FAN PLOTS
 10-24-78

OCT 26 1978

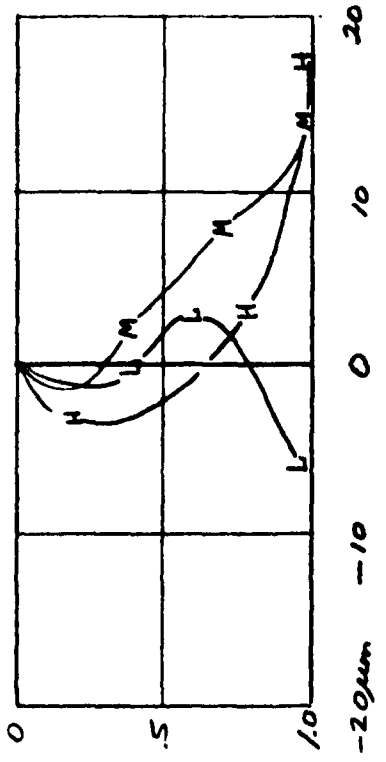

AXIAL FANS

REFOCUS .1328 mm

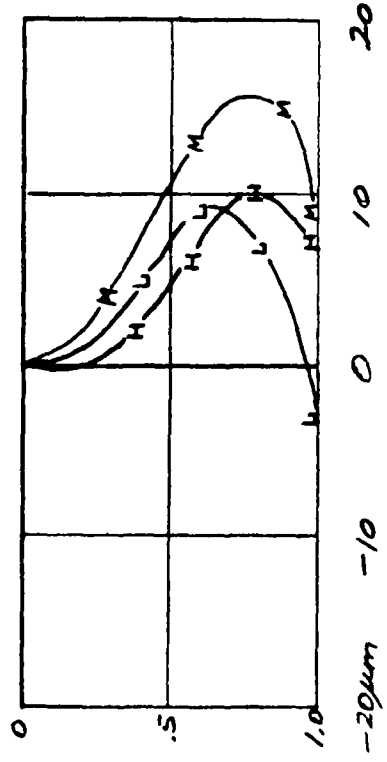

SAGITTAL FIELD FANS

OCT 26 1978

EQUAL WEIGHTING:

$\lambda = .75 \mu\text{m}$

$.860 \mu\text{m}$

$.657 \mu\text{m}$

● AXIS

□ TAN Q.B FLD

○ SAG Q.B FLD

REFOCUS = 0.0768 mm
WORST ORIENTATION
OF
DECENTERED OBSCURATION
(H)

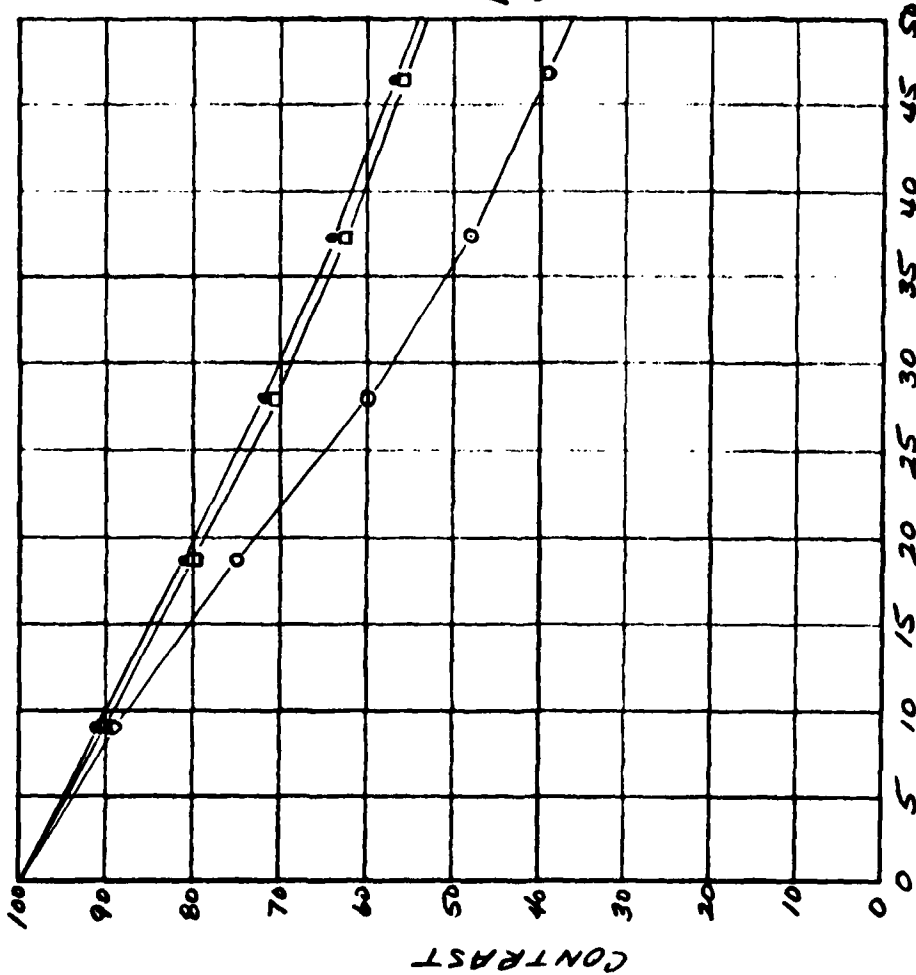

CATIES VNF0V
OBSCURED
SINE WAVE MTF
10-27-78

APPENDIX B TO R&D STATUS REPORT NO. 26

(6 pages)

Alpha
Optical Systems, Inc.

P.O. BOX 912 • 1611 GOVERNMENT STREET
OCEAN SPRINGS, MISSISSIPPI 39564
TELEPHONE 601 875 0211

cc: D. PULTORAK

10 November 1978

General Electric Corporation
901 Broad Street
Utica, New York 13502

Attention: Mr. P. H. Wing
Subject: CATIES CDR Action Items

Dear Mr. Wing:

1. Action Item 3 "Objective Index Shift Study" has been completed. Due to index sensitivity, the final optical design of the objective lens has been optimized using the melt data of the glass which will be used for elements 2 and 3. No submittal is required for this action item.
2. Attached is Alpha's submittal for action item ⁴ "Thermal Sensitivity" and action item 7 "Interface Tolerances all Major Subassemblies".

Very truly yours,
ALPHA OPTICAL SYSTEMS, INC.

John M. Fahnestock Jr.
John M. Fahnestock Jr.
President

JMF:bj

cc: Dan Pultorak with attachments

RECEIVED
NOV 14 1978
P. H. WING

ALPHA OPTICAL SYSTEMS, INC.
INTER-OFFICE MEMO

TO: J. M. Fahnestock, Jr.
FROM: R. R. Weaver
DATE: 10 November 1978
SUBJECT: CATIES Interface Tolerances

The following is a mounting interface tolerance summary for the CATIES optical subassemblies. The tolerances are a result of a computer tolerance analysis for the preliminary optical design presented at the CDR. The final optical design will consist only of fitting the lens elements to existing test glasses, and actual glass index data, and no change in the tolerance requirements will result.

FIELD FLATTENER MOUNTING (Ref. SK1167011)

Decenter

The field flattener must be mounted so that alignment with respect to the objective lens axis is within ± 0.005 ".

Tilt

Tilt alignment with respect to the objective lens axis must be within ± 2.0 mrad.

Axial Position

The axial position must be within ± 0.010 of the nominal position (12.577" dimension shown on SK1167011).

VERY NARROW FIELD OF VIEW RELAY ASSEMBLY (Ref. SK1167013)

Decenter

Decenter of the relay assembly up to 0.020" will have no detectable effect on the final image quality. However, a 0.002" decenter will shift the image centerline 0.0063" in the final image plane.

The boresight repeatability requirement of paragraph 3.2.1.5 of the specification is ± 0.1 mrad, which for the 800mm focal length converts to image stability/repeatability for the VNFOV of ± 0.003 ".

Decenter (Cont)

If the LDR is initially aligned to the VNFOV optic axis, the basic decenter positioning of the relay can be ± 0.020 ". However, the relay positioning must be repeatable and stable to within ± 0.001 ".

Tilt

Tilt in the relay assembly of 1.0 mrad has no detectable effect on image quality. A 1.0 mrad tilt will shift the final image centerline 0.004".

The boresight stability requirement stated above requires that after the initial setup, the relay assembly must be repeatable and stable in angular alignment to within ± 0.75 mrad.

Axial Positioning

Axial motion of 0.002" for the relay assembly will move the final image 0.0068". To remain within a diffraction depth-of-focus, image motion must be less than 0.002". Therefore, the axial position must have repeatability/stability from the initial setting of ± 0.00059 ".

NARROW FOV RELAY ASSEMBLY (Ref. SK1167014)

Tolerancing for the narrow FOV relay assembly given below has been derived using the same procedure and the boresight requirement as for the VNFOV.

Decenter

Decenter of the relay assembly of 0.002" will shift the image centerline by 0.0035". The image repeatability requirement for the 267mm focal length is ± 0.001 ". Therefore, relay repeatability/stability must be within ± 0.00057 ".

Tilt

A 0.38 mrad tilt of the relay assembly will have no detectable effect on image quality. To meet the boresight repeatability requirement, the relay assembly must be repeatable and stable in angular alignment to within ± 0.125 mrad.

Axial Positioning

To remain within two diffraction depths-of-focus, image motion must be less than 0.001". Therefore, the relay must have axial position repeatability/stability of ± 0.002 " from the initial setting.

WIDE FOV RELAY ASSEMBLY (Ref. 1167012)

Decenter

Decenter of the relay assembly of 0.002" will shift the image centerline by 0.0024". The image repeatability requirement for the 80mm focal length is ± 0.0003 ". Therefore, relay repeatability/stability must be ± 0.00025 ".

Tilt

A 0.50 mrad tilt of the relay assembly will have no detectable effect on image quality. To meet the boresight repeatability requirement, the relay assembly must be repeatable and stable to within ± 0.15 mrad.

Axial Positioning

To remain within two diffraction depths-of-focus, image movement must be less than $\pm .001$ ". Therefore, the relay must have axial position repeatability/stability of $\pm .001$ " from the initial setting.

RR Weaver

R. R. Weaver
Chief Engineer

RRW:bj

EX

ALPHA OPTICAL SYSTEMS, INC.
INTER-OFFICE MEMO

To: J. M. Fahnestock, Jr.
From: R. R. Weaver
Date: 10 November 1978
Subject: Thermal performance of the CATIES TV Optical System

The objective lens is a modification of the 410mm focal length air antenna lens supplied to G.E. by Alpha in April 1977. The glass types, and number of elements is the same. The overall lengths and TV clear apertures are almost identical. A complete thermal analysis and thermal test of the 410mm lens showed that the image plane shifted away from the lens (back focus increased) by 0.026" for a +50°C temperature change from ambient. No noticeable degradation in image quality was observed. A comparison of the sensitivity analysis of both lenses indicates that the CATIES objective lens will have a similar image motion (direction and magnitude) for a +50°C temperature change.

The objective image (system prime image) serves as the object for each of the 3 relays. Longitudinal motion of the prime image results in a shift of the final image in the same direction, the amount of which is different for each relay.

The sensitivity analysis shows that in each relay, the thermal effect which dominates final image shift is the change in refractive index of the glass elements with temperature. In each relay this effect will cause a plus (increased back focus) final image plane shift for plus temperature change. This effect will be different in magnitude for each relay and will add to the plus final image shift caused by the prime image shift.

VERY NARROW FOV SYSTEM

		<u>Final Image Shift</u>
50°C Prime image shift	+ .026" =	+ .101"
50°C Relay Index Change	=	+ .024"
	Total:	+ .125

NARROW FOV SYSTEM

		<u>Final Image Shift</u>
50°C Prime Image Shift	+ .026" =	+ .013"
50°C Relay Index Change	=	+ .029"
	Total:	+ .042"

OK

IOM - 11/10/78
R. R. Weaver/J. M. Fahnestock, Jr.
Page 2

WIDE FOV SYSTEM

50°C Prime Image Shift +.026"	=	+ .025"
50°C Relay Index Change	=	<u>+ .001"</u>
Total		+ .026"

None of the above estimates include the effects of temperature changes in the mounting structure. For a temperature increase, the TV camera surface will move in a positive longitudinal direction with respect to the lens system and will tend to track the lens image motion. Alpha is unable to estimate this effect because no information regarding mounting of the lens subassemblies or the camera is available. It is, therefore, not possible to estimate the amount of defocus that will result in any field-of-view for a 50°C temperature change.



R. R. Weaver
Chief Engineer

RRW:bj

APPENDIX C OF R&D STATUS REPORT NO. 26

Alpha
 &
Optical Systems, Inc.

P.O. BOX 912 * 1611 GOVERNMENT STREET
 OCEAN SPRINGS, MISSISSIPPI 39564
 TELEPHONE 601/875-0211

22 November 1978

General Electric Corporation
 901 Broad Street
 Utica, New York 13502

Attention: Mr. P. H. Wing
 Subject: CATIES CDR Action Item 6 "Coating Specification"

Dear Mr. Wing:

Alpha has reviewed the coating specifications called out on the baseline drawings and considers them to be generally acceptable. Alpha proposes slight changes in transmission or reflectance requirements based on manufacturers data and experience with LLLTV/Laser coatings.

Below is the baseline specification followed by the proposed Alpha specification for each coating requirement:

Objective Lens Elements

Baseline	Coat R1 for reflectance $\leq 0.25\%$ @ $\lambda = 0.72\mu\text{m}$ and $\lambda = 1.06\mu\text{m}$. Coating transmission to be $\geq 99\%$ for $0.65 \leq \lambda \leq 0.85\mu\text{m}$.
Alpha	Wide Band Antireflection Coating: Reflectance $\leq 0.3\%$ at 0.723 and 1.064 microns Reflectance $\leq 0.5\%$ ave. from 0.65 to 0.85 microns Absorption and scattering loss $\leq 0.6\%$ Quality provisions per coating specification 1167901.

Relay Lens Elements

Baseline	Coat R1 and R2 for transmission $\geq 99\%$ for $0.65 \leq \lambda \leq 0.85$
Alpha	Wide Band Antireflection Coating: Reflectance $\leq 0.5\%$ Ave. from 0.65 to 0.85 microns Absorption and scattering loss $\leq 0.6\%$ Quality Provisions per coating specification 1167901.

α

J. M. Fahnestock, Jr./P. H. Wing
Page 2 - 22 November 1978

Zoom Illuminator Elements

Baseline Coat R1 and R2 for transmission > 99% for
 $\lambda = 0.72\mu\text{m}$.

Alpha Coating: Laser "V" Coat
 Reflectance $\leq 0.3\%$ @ 0.723 microns
 Absorption and scattering loss $\leq 0.6\%$
 Coating shall meet the hardness and
 adherence requirements of MIL-M-13508.
 Coated witness plate shall be tested
 for hardness and adherence per MIL-M-
 13508, Para. 4.4.5 and 4.4.6

Very truly yours,
ALPHA OPTICAL SYSTEMS, INC.

John M. Fahnestock, Jr.
President

JMF:bj

cc: Dan Pultorak

COMMON APERTURE TECHNIQUES
FOR
IMAGING ELECTRO - OPTICAL SENSORS (CATIES)
R&D STATUS REPORT NO. 27

I. GENERAL

This twenty-seventh R & D Status Report describes the activities of GE/AESD in developing a Common Aperture Technique for Imaging Electro-Optical Sensors (CATIES) Program under Contract F33615-76-C-1135, Item No. 0002, CDRL Sequence 2.

II. TECHNICAL

A. SUMMARY

1. Alpha Optical Systems has received raw glass, and expects to meet scheduled deliveries (weeks of 22 January and 26 March).
2. The spectral separator fractured during processing at Valtec, and delivery is not anticipated before the end of January.
3. Console wiring is complete, and all circuitry is operational. Remote controls for the TV camera and thermal imager have been tested with 40-foot cables.
4. Video switching and display circuitry in the interface electronics unit, and the motor drive circuits for the mechanical assemblies fabricated to date, have been tested.
5. The night TV camera has been operated with the new gating module. EMI, prevalent in the earlier model, was not experienced.
6. The thermal imager (TIS) has been operated with the CATIES controls. The isolation transformer unit supplied with the system has been integrated into the console. Critical timing pulses for

synchronizing the TV and TIS (to provide split-screen and registered video) were, apparently, not brought out to the external connector as indicated in the Philco interface document. The Air Force is looking into the matter.

7. Detailed drawings for the laser shutter, laser support brackets, and turret assembly have been released to the model shop for fabrication. Drawings for the transfer housing and the boresight source assembly are nearly complete, requiring only certain interface dimensions (as yet undetermined).

8. The infrared target projector has been received from Electro-Optical Industries, but was damaged in transit. The system will be realigned at GE.

B. OPTICS

1. Alpha Optical Company foresees no significant obstacles in meeting the required delivery date. Optical element drawings are complete, although not yet received by GE. Detailed mechanical drawings are now in progress. An updated detailed schedule (figure 1, at end of report) was prepared, based on the most recent promised deliveries of various optical assemblies.

2. The reflecting surface to be cemented to the first element of the common objective will be 1-5/8 inches in diameter. This number, based on the final zoom-lens design, allows for a 0.094-inch clearance around the outside edge for alignment-tolerances and edge-defects. The cemented element location is such that no obscuration of the WFOV aperture occurs; approximately 9.8% of the VNFOV aperture is obscured.

3. On 20 December, Valtec notified GE that the spectral separator had been accidentally dropped, and was fractured. This was the date that fabrication was to have been completed and coating begun. Valtec is currently trying to locate a new substrate, and hopes to deliver by the end of January. This delivery would coincide with delivery of the zoom lens elements from Alpha, and may cause some internal scheduling problems for assembling and aligning the CATIES hardware.

4. The optics for the boresight spot assembly have been assembled and tested. Critical dimensions for the source housing and aperture have been established, and detailed drawings for this assembly are now being prepared.

C. MECHANICAL

1. Most of the optical-assembly detailed drawings are complete, and current model-shop estimates-to-fabricate are higher than anticipated. Many of the machined parts are large and unwieldy: very often requiring special tooling for handling and cutting. In some instances, the design has been modified to reduce the amount of machining needed; make-or-buy decisions are being executed to reduce costs. (The thrust lift, described in the previous monthly report, is one example where considerable savings were realized.)

2. A drive motor and eight special (non-standard) gears are on order for the turret assembly. Delivery of these parts, along with a quantity of bearings, clamps, and shims, is expected sometime in January.

3. The only mechanical assembly not yet detailed is the zoom lens for the lead vapor laser insertion. This task will be completed during the next report period.

4. The lead vapor laser support mount and bracketry is being fabricated in the model shop. SSL will ship the laser to GE with the laser head assembly dismantled (to minimize possible damage during transit). Reassembly will have to be accomplished at GE, Utica. In accordance with the Air Force contract, SSL intends to ship the equipment directly to Utica on, or before, 5 January. (This requires Air Force acceptance of the laser at SSL.) A date of 3 January (not firm) is being established for final sign-off, but depends on whether Wolfgang Shubel is available to witness the acceptance tests.

D. ELECTRICAL

1. The azimuth, elevation, and range LED circuitry is now operational, and schematics and layouts have been updated.
2. Final installation and debugging of the video processing boards (i.e., split screen, registered video) is complete, and drawings have been updated.
3. The GE-fabricated TIS cables (for remote operation capability) have been successfully substituted for the TIS test cables shipped with the equipment. Integration of this equipment with the control console is also complete, except that vertical drive and composite sync pulses are not provided at the pin locations identified in the Pave Tack interface document prepared by Philco.

Without these pulses, the TV and TIS cannot be made to operate synchronously for split-screen and registered-video-display effects.

4. The night camera video quality in both active and passive operating modes is vastly improved by the new design for the high voltage gating module. The next possible EMI source of concern is associated with the pulse forming network of the lead vapor illuminator itself. This will be checked during the next report period.

R&D STATUS REPORT NO. 28

CATIES ACTIVITY SUMMARY

Effective January 14th, all in-house efforts on CATIES were temporarily suspended except for minimal subcontractor monitoring activities. This action is made necessary by Alpha Optical delivery slippage from FW 13 to FW 16, including consideration of the risk of additional delays in optics delivery. Another factor is the continuing delays in delivery of the lead vapor illuminator from SSL due to low output power, intermittent operation and high voltage arcing problems.

While cutting one of the element blanks for the common objective for Alpha, the glass manufacturer broke the piece (shattered due to internal stresses.) This leaves no spare glass for fabricating the two elements of this glass type to be supplied. The problem is that one of the elements is extremely sensitive to index of refraction. If it breaks during processing, it can be replaced only with glass originating from the same melt without initiating a costly redesign effort. Preliminary information based on inputs from Shott and Alpha is that replacement glass is in process and would result in a three week delay in optics delivery.

Alpha submitted all optical element and mechanical detail drawings. These have been checked for compatibility with AESD fabricated parts and assembly drawings. Two potential problem areas have been identified and discussions with Alpha indicate that required changes can be made without significant rework of existing parts. All GE/AESD mechanical assemblies have been detailed sufficiently so that model shop has been able to provide accurate estimates of the remaining fabrication time necessary.

The GFE Conrac monitors have been shipped from Wright-Patterson Air Force Base.

The spectral separator delivery has been delayed by Valtec approximately two weeks (mid February) due to late receipt of raw glass and internal scheduling problems.

The zoom lens optics will be shipped from Alpha early in FW 06.

The support /lift assembly for the system has been received and moved up to the lab.

The GFE 5 kilowatt high voltage power supply (for the lead vapor illuminator) has also been received.

R&D STATUS REPORT NO. 29

CATIES ACTIVITY SUMMARY

The GFE Conrac monitors have been received, modified and mounted in the remote control console for demonstration purposes. The special effects circuitry (split screen and video mix) is operational.

A problem with the FLIR (rotating mirror would not reach synchronization speed), was resolved by implementing a chamber evacuation procedure.

Alpha Optical has submitted an Acceptance Test Procedure (ATP) for the TV and zoom optics for approval. This completes all software submittal requirements for the CATIES optics. The coated zoom optics have also been received from Alpha.

Another optical element for the common objective has been broken during processing. The last remaining spare substrate will be utilized to replace the broken piece since Schott Optical will not be able to supply new glass until May or June. Element #3 has been fabricated and element #1 will take approximately two weeks. Without further complications both elements will be hand carried to Valtec for coating during the week of March 19th (FW 12). With this schedule a final delivery of FW 16 for all the TV optics is still possible. Contingency plans are being formulated in the event of further glass breakage, which could permit assembly of the CATIES system to continue using off the shelf substitute glass until the required glass is delivered by Schott.

Valtec has notified GE that the fabricated spectral separator will reach the coating facility during the week of March 5th. Set-up and actual coating is expected to take approximately two weeks. This is a new input and is being looked into by GE purchasing personnel.

The lead vapor illuminator was received on March 1st and is being readied to operate with the GFE power supply. This task is being performed to ensure that the equipment has not been damaged in transit and to familiarize GE/AESD with loading and operation procedures.

Since the laser and zoom optics have now been received and in order to minimize future risk and permit an efficient start-up of engineering activities, it was recommended in a telecon with J. Stewart on February 28th that several tasks be started immediately. These tasks along with manpower estimates are listed below.

<u>Task</u>	<u>Function</u>	<u>Man Days (Est.)</u>
Fabricate Laser Support Structure	Model Shop	15
Operate Laser	Eng.	3
Fabricate Zoom Optics Assembly	Model Shop	30
	Drafting	2
Test Optics & Coat Turning Mirror	Eng.	4
Fabricate Optics Transfer Housing	Model Shop	5
Witness Separator Testing & Pre-Align Optical Bench	Eng.	13
Review and Amend Zoom Optics ATP	Eng.	2

Total value is \approx \$13K

A new final system delivery, schedule and manpower runnout will be completed and forwarded to the customer during the next report period.

Contract expenditures and commitments as of 28 February were \$1,004,000. This comprises an expended value of \$933,000 and a committed value of \$71,000.

R&D STATUS REPORT NO. 30

CATIES ACTIVITY SUMMARY

3 March 1979 - 31 March 1979

A response to the Acceptance Test Procedure (ATP) submitted by Alpha Optical was prepared and is attached (attch. 1) to this report. Alpha has completed the fabrication of all TV optical elements. We have also been informed that scheduling problems with coating vendors may result in a one week additional delay (see attch. 2). A change in the method of attaching and supporting the lead vapor insertion prism has been mutually agreed upon between Alpha and GE to minimize the risk of breaking the first element of the common objective during fabrication and coating. Now instead of coring and cementing to that element, the metal reflecting surface will be attached to the housing of the common objective and still retain full adjustment capability. Obscurations in the TV path (for the narrow and very narrow FOV) will still be the same as previously determined during the control phase of the optical design.

The Honeywell imager cooling system needs to be purged and recharged with helium. It has been determined in discussions with Honeywell that the detectors are not getting cold enough and the failsafe circuitry is preventing biasing of the array. They are sending a coupling which will mate to the imager, and the Air Force (Brian Yasuda) is sending a high pressure regulator so the periodically required maintenance procedure can be carried out. It is expected that GE support personnel will have the necessary valves and fittings and can perform the recharging operation. However if there is a leak in the system or if all parts are not available it may be necessary for the Air Force to arrange for necessary maintenance with Honeywell.

It was learned from Valtec that they were afraid of breaking the Germanium Spectral Separator during the final cutting operation, so as a precaution they sent it back to the supplier (Eagle-Pitcher) for this step. Since then, it has been returned and the first side coated. April 3 is the date that has tentatively been selected for witnessing final tests.

The lead vapor illuminator has been operated at two watts (start-up time is approximately one hour). A circuit has been designed and installed which detects "thyatron dumping" (laser cuts out), shuts down primary power and reactivates laser operation without requiring operator intervention. The new circuit was tested and seems to be working perfectly since no failures occurred during a 2-hour test. The laser cavity was cleaned and quartz tubing was inserted per SSL's recommendation to minimize sputtering of lead on the end windows. Operation was considerably more stable, but some double imaging of the output spot occurred, probably as a result of the quartz near the front window. This piece will be removed prior to any further operation of the laser.

R&D STATUS REPORT NO. 31

CATIES ACTIVITY SUMMARY

1 April 1979 - 30 April 1979

Alpha Optical has completed assembly of the objective and the three relays. Complete measurements on the system have not been carried out, but as a preliminary check on-axis MTF values were determined.

Objective w/VN FOV 60% @ 32 lp/mm (Slit in horizontal and vertical with obstruction of approximately same size and shape)

Objective w/N FOV > 70% @ 32 lp/mm (Some coma noted, probably will be eliminated)

Objective w/W FOV 75% @ 32 lp/mm (Again some coma existed which they are working on)

Acceptance testing has been scheduled at Alpha for May 3rd. The turning mirror (obscuration) attached to the common objective will not be complete at this time, but will be shipped by May 18th. This unit was scratched and had to be sent back for recoating.

A trip was made to Valtec to review reflectance and absorption data obtained on the spectral separator. Coating quality appears to be excellent and the unit was received at AESD on April 13. Copies of the curves have already been forwarded to the customer.

The problem with the Honeywell thermal imager described in the last monthly report (lack of coolant) has been resolved and the equipment is now operating normally. It appears that only this routine maintenance procedure was required and that no abnormally high leak rate exists within the system.

Jim Stewart visited AESD on April 19 and 20 to review progress to date and schedule for completing assembly, alignment and test of the CATIES system. A current schedule is attached which assumes a full resumption of CATIES activities on May 7th. At this time all subcontracted items will have been received (or be enroute to AESD. Also, all major assemblies currently being fabricated in Model Shop will be ready for final assembly and integration. This includes the relay turret, zoom lens assembly, illuminator support, and transfer housing.

The following concept for the CATIES test and delivery sequence was discussed and agreed upon although methods for accomplishing the required logistics have not yet been determined:

1. Engineering Lab Tests at 901 Broad Street
2. Operational Testing at GE's Cazenovia Range

3. Acceptance test at Cazenovia and then delivery from Cazenovia to AFAL Building 622
4. Operate system and familiarize responsible tower personnel with CATIES hardware

AD-A087 558

GENERAL ELECTRIC CO UTICA NY AEROSPACE ELECTRONIC SY--ETC F/G 20/6
COMMON APERTURE TECHNIQUES FOR IMAGING ELECTRO-OPTICAL SENSORS --ETC(U)
FEB 80 F33615-76-C-1135

UNCLASSIFIED

79-556C0-10

AFWAL-TR-80-1012

NL

4 of 4

80A

20-100A



END

DATE

FORMED

DTIC

DTIC

R&D STATUS REPORT NO. 32
COMMON APERTURE TECHNIQUES
FOR
IMAGING ELECTRO - OPTICAL SENSORS (CATIES)

I. GENERAL

This thirty-second R&D Status Report describes the activities of GE/AESD in developing a Common Aperture Technique for Imaging Electro-Optical Sensors (CATIES) Program under Contract F33615-76-C-1135, Item No. 0002, CDRL Sequence 2.

II. TECHNICAL

A. SUMMARY

1. Final Acceptance tests were conducted at the Alpha Optics Company plant in Ocean Springs, Mississippi. Performance in all three fields of view is excellent, and meets design goals in practically all areas. The relay assemblies were received at GE on 22 May; the objective was received on 24 May.
2. Spectral separator and pointing mirror have been installed and aligned in their respective housings. The current plan, however, is to assemble all mechanical units, check for fit, make electrical connections, and debug circuitry before installing any glass in the system. This sequence is necessary to minimize the risk of scratching or breaking the optical elements.
3. The turret, zoom lens, and laser shutter have all been assembled and mechanically interfaced with the rest of the system.
4. The optical bench and the illuminator support have been bolted to the hydraulic lift. The transfer housing with levelers has been

installed, as have two 400 Hz, 3 phase blower motors for the thermal imager. Most of the electronic units have also been mounted, and their interconnecting cables clamped in place.

5. The illuminator and thermal imager have been installed to verify the mechanical interface, and to establish cable routes and clamp locations.

B. OPTICS

1. Acceptance tests were finally held at Alpha, on 10 May, and were witnessed by Air Force and GE personnel. Performance in the VNFOV had not been optimized, however, because of problems introduced by a malfunctioning MTF bench. Tests were performed with all three relay assemblies behind the objective, in accordance with Alpha's revised Acceptance Test Plan.

2. It was understood that, once the VNFOV combination had been re-optimized, and the common objective potted and ready to ship, a full set of MTF curves would be run again. Another trip to Alpha was made by GE engineer Dan Pultorak, to verify resolution (i.e., image quality) with each relay in place, and to witness randomly-selected MTF measurements. In general, MTF performance of the narrow and wide FOV combinations were slightly better than measurements made the previous week. VNFOV performance improved from an unacceptable level to one that not only exceeded contractual requirements, but met their design goals (85% of design specification values).

3. MTF curves have already been forwarded to the Air Force. Appendix A of this report contains a typed, revised, copy of

all other measured values, including those performed on the zoom lens elements (for lead vapor illuminator insertion).

C. MECHANICAL

1. Fabrication and, where necessary, rework of the various opto-mechanical assemblies has been completed. A full mechanical and electrical integration of the CATIES system is currently underway.
2. Larger wheels have been installed on the hydraulic lift to provide additional height thereby facilitating movement (i.e., clearing grades, crossing doorway thresholds, entering elevators). Another change is a significant reduction in the descent rate of the platform in order to minimize risk of breakage or misalignment due to sudden shock. Rubber pads have been installed on the metal stops to reduce vibration when the system is being relocated or transported.
3. Several fixtures have been fabricated in the model shop to aid in system alignment. Some rework of the optical bench was also required, to permit use of autocollimation techniques when aligning the pointing mirror assembly and spectral separator.
4. Terminal strip locations and cable routes are being carefully selected to facilitate the removal and reinstallation of various major assemblies for either alignment, test, or maintenance.
5. Vibration isolators were installed on each of the thermal imager blower fans after more conventional methods (e.g., rubber pads, alternate locations) proved inadequate.

D. ELECTRICAL

1. Wiring of the laser shutter and the relay turret is complete. The associated electronics is being debugged.
2. Zoom lens and boresight assemblies will be accorded similar treatment just before the optical bench prealignment is performed at the GE French Road, Utica facility.

E. MEETINGS

Two meetings, summarized in figure 1, were held during this report period.

<u>Date and Place</u>	<u>GE/AESD</u>	<u>Attendees</u>		<u>Main Purpose</u>
		<u>Other</u>		
10 May 1979 Alpha Optics Ocean Springs, MS	D. Pultorak M. Kolesa J. Antonelli	J. Stewart (AF) W. Martin (AF) J. Fahnestock (Alpha) G. Martin (Alpha) S. Scharnhorst (Alpha) S. Manella (Alpha)	Witness Acceptance Tests	
17 May 1979 Alpha Optics Ocean Springs, MS	D. Pultorak	J. Fahnestock (Alpha) D. Weaver (Alpha) S. Scharnhorst (Alpha)	Verify Image Quality Monitor MTF Measurements	

Figure 1. Meeting Summary for May 1979 Report Period

APPENDIX A
TO
R&D STATUS REPORT NO. 32

COMMON APERTURE OPTICAL SYSTEM
ACCEPTANCE TEST DATA SHEET

Subassembly Part Nos.

Serial Nos.

1167998, Objective Ass'y.	N/A
1167997, VNFOV Relay Ass'y.	N/A
1167996, NFOV Relay Ass'y.	N/A
1167995, WFOV Relay Ass'y.	N/A
1167994, Lens Ass'y., Elem I, Zoom Illum.	N/A
1167993, Lens Ass'y., Elem II & III, Zoom Illum.	N/A
1167992, Lens Ass'y., Elem IV & V, Zoom Illum.	N/A

1.0 EFFECTIVE FOCAL LENGTH (A.T.P. Para. 5.0)

Object Separation: .1927 inches

	IMAGE SEPARATION (INCHES)	EFL = 196 I/O (INCHES)	EFL SPEC. (INCHES)
VNFOV	.031	31.53	31.5 \pm 0.63
NFOV	.01025	10.425	10.5 \pm 0.21
WFOV	.003	3.051	3.15 \pm 0.063

2.0 MTF TESTS (A.T.P. Para. 6.0)

2.1 Very Narrow FOV

MTF Curves Attached: Yes x No _____

2.2 Narrow FOV

MTF Curves Attached: Yes x No _____

2.3 Wide FOV

MTF Curves Attached: Yes x No _____

CODE IDENT NO. 54287	DRAWING NO. 1167902
REV A	SHEET 14

3.0 TRANSMISSION EFFICIENCY AND T/NO. (A.T.P. Para. 7.0)

	% Transmission	T/No.	Specification
VNFOV	66%	7.5	7.5
NFOV	62%	3.3	3.3
WFOV	66%	3.2	3.2

4.0 RELATIVE ILLUMINATION (A.T.P. Para. 8.0)

4.1 VNFOV

Distance Off-Axis (inches)	Measured % Illumination	Specification %
0.080	98%	98
0.236	96%	96
0.315	93%	92

4.2 NFOV

Distance Off-Axis (inches)	Measured % Illumination	Specification %
0.080	100	98
0.236	92	96
0.315	90	92

4.3 WFOV

Distance Off-Axis (inches)	Measured % Illumination	Specification %
0.0000	96	98
0.236	98	95
0.315	90	90

CODE IDENT NO. 54287	DRAWING NO. 1167902
REV A	SHEET 15

5.0 VEILING GLARE (A.T.P. Para. 9.0)

VNFOV: 3 %

NFOV: 4 %

WFOV: 4 %

Specification: 8%

6.0 ILLUMINATOR OPTICS TEST (A.T.P. Para. 10.0)

*DATA-PREVIOUSLY TAKEN

6.1 ILLUMINATOR POWER (A.T.P. Para. 10.1 and 10.3)

Mode	Angular Image Size (minutes)	Magnification	
		Measured	Specification
16 mrad	6.0	1.76	1.78
48 mrad	18.0	5.26	5.33

6.2 ILLUMINATOR BLUR (A.T.P. Para. 10.2 and 10.3)

Mode	Angular Image Size		Angular Errors (Milliradians)	
	Axis	Field	Axis	Field
16 mrad	60 sec	60 sec	.29 mrad	.29 mrad
48 mrad	80 sec	80 sec	.39 mrad	.39 mrad

6.3 SUBASSEMBLY SPACING (A.T.P. Para. 10.1.1)

Mode	Dimension A	Dimension B
16 mrad	5.533 in.	1.957 in.
48 mrad	6.253 in.	.140 in.

CODE IDENT NO. DRAWING NO.

54287

1167902

REV A

SHEET 16

7.0 BACK FOCAL DISTANCE (A.T.P. Para. 11.0)

	Measured (inches)	Specification (inches)
VNFOV	1.838 with haze filter and face plate 1.773 in air	1.765 \pm .120 -.060
NFOV	1.827 with haze filter and face plate 1.762 in air	1.765 \pm .115 -.055
WFOV	1.817 with haze filter and face plate 1.752 in air	1.765 \pm .120 -.060

NOTE: This measurement does not indicate parfocalization between delays.

8.0 OPTICAL/MECHANICAL AXIS RUNOUT (A.T.P. Para. 12.0)

Measured Image Runout (inches)

WFOV: .004"
 NFOV: .003"
 VNFOV: .002"

9.0 VISUAL RESOLUTION (A.T.P. Para. 13.0)

Resolution Chart Group Resolved

	MTF Plane	Best Focus	
VNFOV	3-5	4-5	Δ .004"
NFOV	3-1	4-1	Δ .002"
WFOV	1-6	2-6	Δ .0005"

TESTED BY: RS. Schenkert
 ALPHA OPTICAL SYSTEMS, INC.

DATE: May 17, 1979

WITNESSED BY: Don Potholch

DATE: May 17, 1979

--

CODE IDENT NO. 54287	DRAWING NO. 1167902
REV A	SHEET 17

COMMON APERTURE TECHNIQUES
FOR
IMAGING ELECTRO-OPTICAL SENSORS (CATIES)
R&D STATUS REPORT NO. 33

I. GENERAL

This thirty-third R&D Status Report describes the activities of GE/AESD in developing a Common Aperture Technique for Imaging Electro-Optical Sensors (CATIES) Program under Contract F33615-76-C-1135, Item No. 0002, CDRL Sequence 2.

II. TECHNICAL

A. SUMMARY

1. Electrical circuitry for the turret, zoom lens and laser shutter assembly has been "debugged". All circuits in the Interface Electronics Unit (IEU) have been operated. Final adjustments and component selection (to establish limits) will be performed prior to shipping the CATIES system to Cazenovia.
2. The system (less the Lead Vapor Illuminator) has been transported to the Measurements Lab at the GE French Road facility for optical prealignment and installation of the glass elements.
3. The Zoom Lens Assembly (for Lead Vapor Illuminator insertion) has been set for the proper magnification assuming a beam divergence of nine milliradians.
4. ITT diagnosed the Intensified Camera problem as a defective second generation intensifier. A replacement unit was coupled to a

first generation device, which still did not provide adequate performance (only 20 line pairs per millimeter resolution). ITT is searching for an alternate device which when coupled will provide adequate performance.

5. Alpha Optical shipped a turning mirror for the illuminator (to be installed on the front of the Common Objective Assembly). This mirror does not meet flatness specifications and the polished surface is scratched. The mirror will be installed temporarily while Alpha Optical fabricates a new unit. The new mirror is expected to be complete by the second week in July.

6. Copies of the System Safety Program Plan were mailed to the Air Force for approval on June 1.

7. Copies of the Acceptance Test Plan were mailed to the Air Force for approval on July 5.

8. Measurements are being made at the system and component levels. Data items as defined in the Acceptance Test Plan will be supplied at the final acceptance test at Cazenovia. Photographs of various assemblies are being obtained for incorporation into the Operation and Maintenance Manual.

B. OPTICS

1. Due to Alpha Optical's problem in fabrication of the Turning Mirror this element will not be available until about the time that the system is being prepared for transportation to Cazenovia. GE/AESD has suggested an alternate approach to ALPHA for obtaining desired flatness and will expedite transferring the completed item

to Utica. The machined part is polished, Kanigan coated and then repolished. The unit is small and it is difficult to hold the flatness at the edges of the surface. Currently a special fixture is being fabricated and coated that will effectively enlarge the surface during the final polishing stages.

2. The zoom lens elements are installed in the mechanical assembly and the mechanical stops have been located to achieve the desired magnification corresponding to the very narrow and narrow horizontal fields of view.

3. The CATIES system was transported by truck to the Measurement Lab at the GE French Road facility. The optical bench was removed from the hydraulic lift and transferred to a 5 by 6 foot granite slab. A reference was established and the mechanical and optical assemblies were systematically installed and aligned. The planned sequence for performing these tasks is shown in Appendix A. The prealignment revealed that only slight variations of this sequence were necessary in phase 1 and 2. The CATIES system will be returned to the GE Broad Street facility on July 3 and supported on the 13 foot focal length collimator to achieve parfocalization of the three relays (phase 3).

C. MECHANICAL

1. The mechanical tasks are complete except for small hardware items, modification of piece parts as necessary and updating assembly drawings. Additional alignment fixtures were fabricated during the prealignment phase.

2. Continued support from a logistics standpoint is still required for transporting and positioning the optical bench in each of its operating locations during these last critical alignment and test operations.

D. ELECTRICAL

1. The laser shutter has been remotely activated from the control console. The threshold voltage for the sensing diode in the shutter has not yet been established. This diode provides a laser ready indication at the console.

2. The turret circuitry starts, stops and controls the direction of movement of the relay lenses as desired. The relays index to the location indicated at the remote control console. If the control is repositioned while power is off the relays will, upon application of power, index to the selected location.

3. The zoom lens has two groups of elements that must be driven to new locations each time the camera field of view changes. Originally this circuitry was designed to operate fixed lens assemblies in a two position turret. This concept changed when the rawbeam divergence characteristics of the Lead Vapor Illuminator could not be precisely established. The circuits have been modified to drive a motor coupled to both moving element assemblies via a slip clutch. To insure that the motor runs long enough for both groups of elements to reach their mechanical stops a time delay circuit which applies power to the drive motor for approximately 30 seconds has been incorporated.

4. The Remote Control Console and Interface Electronics Unit was not taken to the Measurements Lab during the optical prealignment. Therefore, DC power supplies were used to operate the motor driven assemblies during this phase of testing.

E. MEETINGS

No meetings were held during this report period.

F. MISCELLANEOUS

1. This is the last monthly status report before system delivery. The following list represents current estimates of planned major events.

- a. System transported to long focal length collimator at GE Broad Street facility (July 3).
- b. Parfocalization complete and system returned to the Electro Optics Lab (July 12).
- c. System shipped to Cazenovia Test Range via air suspension van (July 23).
- d. System delivered to WPAFB (August 2).

2. The System Safety Program Plan (SSPP) and the Acceptance Test Plan have been sent to the Air Force for approval. The data identified in the checklist of the Acceptance Test Plan are being gathered into a single package. Such items as field of regard limits and thermal imager MRT data are being measured during final alignment and assembly as minimal set-up and transfer of test equipment is required at this time.

APPENDIX A TO R&D STATUS REPORT NO. 33

BASIC CATIES ALIGNMENT

Phase I

1. Pointing Mirror (within its housing).
2. Spectral Separator (within its housing).
3. Alignment and divergent magnification tests.
4. Rotating Bearing Alignment.
5. Assembly/Alignment of Pointing Mirror to Spectral Separator with reference to Rotating Bearing.
6. Establishment of L.O.S. at ∞ , parallel to transfer plate optical axis. Double pass.
7. Align laser optics bed and boresight laser using A.C. to simulate laser as reference.

Phase II

1. Align box hole for divergent lens in center of common objective aperture.
2. Align centers of turret holes to be concentric with field lens aperture. radially and axially.
3. Mount microscope inside camera derotation neck, align and center.
4. Use wide F.O.V., 80 MM E.F.L. lens as boresight reference. Project beam from longest F.L. auto-collimator aligned on center axis. Preliminary alignment with laser on center spot.
5. Switch remaining lenses in just to see alignment boresight using laser spot on axis.

Phase III

1. Parafocalization and maximum resolution on 156" F.L. collimator.
2. Set up on narrow F.O.V. and make the remaining F.O.V.'s parfocal with maximum resolution.
3. Mark center of image on wide F.O.V. for boresight reference by inserting laser spot at the resolution chart center. Keep reference as close as possible to wide F.O.V. for proper boresight.

(NOTE: W.F.O.V. is reference for boresight).

J. F. Antonelli
Electro-Optics Systems Engineering