

MICROCOPY RESOLUTION TEST CHART

NATIONAL BUREAU OF STANDARDS-1963-A

LEVEL II

DELAWARE RIVER BASIN
TRIBUTARY TO SOUTHWEST BRANCH
RANCOCAS CREEK
CAMDEN COUNTY, NEW JERSEY

ADA 087631

CEDAR LAKE DAM

NJ 00407

PHASE 1 INSPECTION REPORT NATIONAL DAM SAFETY PROGRAM

S DTIC
ELECTE **D**
AUG 8 1980
B



ORIGINAL CONTAINS COLOR PLATES: ALL DDC
REPRODUCTIONS WILL BE IN BLACK AND WHITE

APPROVED FOR PUBLIC RELEASE
DISTRIBUTION UNLIMITED.

DEPARTMENT OF THE ARMY

Philadelphia District
Corps of Engineers
Philadelphia, Pennsylvania

THIS DOCUMENT IS BEST QUALITY PRACTICE
THE COPY FURNISHED TO DDC CONTAINED A
SIGNIFICANT NUMBER OF PAGES WHICH DO NOT
REPRODUCE LEGIBLY.

MARCH 1980
APPROVED FOR PUBLIC RELEASE;
DISTRIBUTION UNLIMITED

DDC FILE COPY

DDC FILE COPY

80 87 038

DISCLAIMER NOTICE

THIS DOCUMENT IS BEST QUALITY PRACTICABLE. THE COPY FURNISHED TO DTIC CONTAINED A SIGNIFICANT NUMBER OF PAGES WHICH DO NOT REPRODUCE LEGIBLY.

REPORT DOCUMENTATION PAGE		READ INSTRUCTIONS BEFORE COMPLETING FORM
1. REPORT NUMBER NJ00407	2. GOVT ACCESSION NO. AD-A087 634	3. RECIPIENT'S CATALOG NUMBER
4. TITLE (and Subtitle) Phase I Inspection Report National Dam Safety Program Cedar Lake Dam NJ00407 Camden County, New Jersey...		5. TYPE OF REPORT & PERIOD COVERED FINAL
		6. PERFORMING ORG. REPORT NUMBER
7. AUTHOR(s) RUDOLPH WRUBEL		8. CONTRACT OR GRANT NUMBER(s) DACW61-79-C-0011
9. PERFORMING ORGANIZATION NAME AND ADDRESS Louis Berger & Associates ✓ 100 Halstead St. East Orange, N.J. 07019		10. PROGRAM ELEMENT, PROJECT, TASK AREA & WORK UNIT NUMBERS
11. CONTROLLING OFFICE NAME AND ADDRESS NJ Department of Environmental Protection Division of Water Resources P.O. Box CN029 Trenton, NJ 08625		12. REPORT DATE March 1980
		13. NUMBER OF PAGES 56
14. MONITORING AGENCY NAME & ADDRESS (if different from Controlling Office) U.S. Army Engineer District, Philadelphia Custom House, 2d & Chestnut Streets Philadelphia, PA 19106		15. SECURITY CLASS. (of this report) Unclassified
		15a. DECLASSIFICATION/DOWNGRADING SCHEDULE
16. DISTRIBUTION STATEMENT (of this Report) Approved for public release; distribution unlimited.		
17. DISTRIBUTION STATEMENT (of the abstract entered in Block 20, if different from Report)		
18. SUPPLEMENTARY NOTES Copies are obtainable from National Technical Information Service, Springfield, Virginia 22151.		
19. KEY WORDS (Continue on reverse side if necessary and identify by block number) Dams National Dam Safety Program Embankments Cedar Lake Dam, New Jersey Visual Inspection Spillways Structural Analysis		
20. ABSTRACT (Continue on reverse side if necessary and identify by block number) This report cites results of a technical investigation as to the dam's adequacy. The inspection and evaluation of the dam is as prescribed by the National Dam Inspection Act, Public Law 92-367. The technical investigation includes visual inspection, review of available design and construction records, and preliminary structural and hydraulic and hydrologic calculations, as applicable. An assessment of the dam's general condition is included in the report.		



IN REPLY REFER TO

NAPEN-N

DEPARTMENT OF THE ARMY
PHILADELPHIA DISTRICT, CORPS OF ENGINEERS
CUSTOM HOUSE-2 D & CHESTNUT STREETS
PHILADELPHIA, PENNSYLVANIA 19106

ACCESSION FOR	
THIS	Write Section <input checked="" type="checkbox"/>
DATE	DATE Section <input type="checkbox"/>
DISTRIBUTION/AVAILABILITY CODES	
Dist	SPECIAL and/or SPECIAL
A	TS

04 AUG 1980

Honorable Brendan T. Byrne
Governor of New Jersey
Trenton, New Jersey 08621

Dear Governor Byrne:

Inclosed is the Phase I Inspection Report for Cedar Lake Dam in Camden County, New Jersey which has been prepared under authorization of the Dam Inspection Act, Public Law 92-367. A brief assessment of the dam's condition is given in the front of the report.

Based on visual inspection, available records, calculations and past operational performance, Cedar Lake Dam, initially listed as a high hazard potential structure, but reduced to a significant hazard potential structure as a result of this inspection, is judged to be in fair overall condition. The dam's spillway is considered inadequate because a flow equivalent to 29 percent of the One Hundred Year Flood would cause the dam to be overtopped. To ensure adequacy of the structure, the following actions, as a minimum, are recommended:

a. The spillway's adequacy should be determined by a qualified professional consultant engaged by the owner using more sophisticated methods, procedures, and studies within one year from the date of approval of this report. Within three months of the consultant's findings remedial measures to ensure spillway adequacy should be initiated.

b. Within twelve months from the date of approval of this report, the following remedial actions should be initiated:

(1) The downstream embankment areas at the ends of the culvert wingwalls should be regraded and protected.

(2) Remove trees and brush on the downstream embankment to lessen the piping potential.

(3) Backfill and regrade the downstream backslopes and seed the repaired areas.

c. The owner should develop an emergency action plan that outlines actions to be taken by the operator in the event of an emergency at the dam and a downstream warning system within six months from the date of approval of this report.

NAPEN-N

Honorable Brendan T. Byrne

d. The owner should develop written operating procedures and a periodic maintenance plan to ensure the safety of the dam within one year from the date of approval of this report.

A copy of the report is being furnished to Mr. Dirk C. Hofman, New Jersey Department of Environmental Protection, the designated State Office contact for this program. Within five days of the date of this letter, a copy will also be sent to Congressman Florio of the First District. Under the provision of the Freedom of Information Act, the inspection report will be subject to release by this office, upon request, five days after the date of this letter.

Additional copies of this report may be obtained from the National Technical Information Services (NTIS), Springfield, Virginia 22161 at a reasonable cost. Please allow four to six weeks from the date of this letter for NTIS to have copies of the report available.

An important aspect of the Dam Inspection Program will be the implementation of the recommendations made as a result of the inspection. We accordingly request that we be advised of proposed actions taken by the State to implement our recommendations.

(10) Rudolph / Wrobel

Sincerely,

(9) Final report

James G. Ton

(12) 6/7/71

1 Incl
As stated

(11) Mar 87

JAMES G. TON
Colonel, Corps of Engineers
District Engineer

(13) DAZW61-79-2-0011

Copies furnished:

Mr. Dirk C. Hofman, P.E., Deputy Director
Division of Water Resources
N.J. Dept. of Environmental Protection
P.O. Box CN029
Trenton, NJ 08625

(6) National Dam Safety

Mr. John O'Dowd, Acting Chief
Bureau of Flood Plain Regulation
Division of Water Resources
N.J. Dept. of Environmental Protection
P.O. Box CN029
Trenton, NJ 08625

Program, Cedar Lake Dam (NJ 00407)
Delaware River Basin, ~~Eastern~~
Run Tributary to Southwest
Branch, Rancocas Creek,
Camden County, New Jersey.
Phase I Inspection Report.

410871

JK

CEDAR LAKE DAM (NJ00407)

CORPS OF ENGINEERS ASSESSMENT OF GENERAL CONDITIONS

This dam was inspected on 21 November 1979 by Louis Berger and Associates Inc. under contract to the State of New Jersey. The State, under agreement with the U.S. Army Engineer District, Philadelphia, had this inspection performed in accordance with the National Dam Inspection Act, Public Law 92-367.

Cedar Lake Dam, initially listed as a high hazard potential structure, but reduced to a significant hazard potential structure as a result of this inspection, is judged to be in fair overall condition. The dam's spillway is considered inadequate because a flow equivalent to 29 percent of the One Hundred Year Flood would cause the dam to be overtopped. To ensure adequacy of the structure, the following actions, as a minimum, are recommended:

a. The spillway's adequacy should be determined by a qualified professional consultant engaged by the owner using more sophisticated methods, procedures, and studies within one year from the date of approval of this report. Within three months of the consultant's findings remedial measures to ensure spillway adequacy should be initiated.

b. Within twelve months from the date of approval of this report, the following remedial actions should be initiated:

(1) The downstream embankment areas at the ends of the culvert wingwalls should be regraded and protected.

(2) Remove trees and brush on the downstream embankment to lessen the piping potential.

(3) Backfill and regrade the downstream backslopes and seed the repaired areas.

c. The owner should develop an emergency action plan that outlines actions to be taken by the operator in the event of an emergency at the dam and a downstream warning system within six months from the date of approval of this report.

d. The owner should develop written operating procedures and a periodic maintenance plan to ensure the safety of the dam within one year from the date of approval of this report.

APPROVED:

James G. Tom
JAMES G. TOM

Colonel, Corps of Engineers
District Engineer

DATE:

22 Jul 80

III

PHASE I REPORT
NATIONAL DAM INSPECTION PROGRAM

Name of Dam Cedar Lake Dam Fed ID# NJ 00407 and
NJ ID# 31-78

State Located New Jersey
County Located Camden
Coordinates Lat. 3950.8 - Long. 7455.8
Stream Barton Run Tributary of Southwest Branch
Rancocas Creek
Date of Inspection November 21, 1979

ASSESSMENT OF
GENERAL CONDITIONS

Cedar Lake Dam is assessed to be in a good overall condition and it is recommended that it be downgraded from a high hazard to a significant hazard category. Overtopping of the dam would not greatly increase the danger of loss of life as the downstream flood plain is basically uninhabited. No detrimental findings were uncovered to render a hazardous assessment except further studies are recommended in the future to ascertain the embankment permeability. Remedial actions recommended to be undertaken in the future are 1) regrade and protect the downstream embankment, 2) remove dead root systems on downstream embankment slopes.

This dam has an inadequate spillway capacity, being able to accommodate only 28% of the design flood. Hence, further hydraulic studies are recommended in the future.

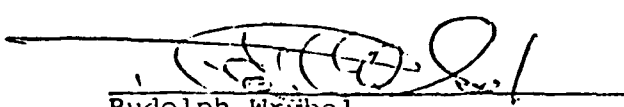
Rudolph Wrübel
Vice President
Louis Berger & Associates, Inc.



OVERVIEW OF CEDAR LAKE DAM

November, 1979

TABLE OF CONTENTS

	<u>Page</u>
Assessment of General Conditions	
Overall View of Dam	
Table of Contents	
Preface	
Section 1 - Project Information	1-4
Section 2 - Engineering Data	5-6
Section 3 - Visual Inspections	7-8
Section 4 - Operational Procedures	9
Section 5 - Hydraulic/Hydrologic	10
Section 6 - Structural Stability	11-12
Section 7 - Assessments/Recommendations/ Proposed Remedial Measures	13-14

FIGURES

Figure 1 - Regional Vicinity Map
Figure 2 - General Plan
Figure 3 - Spillway Details
Figure 4 - Spillway Section

APPENDIX

Check List - Visual Inspection	
Check List - Engineering Data	
Photographs	
Check List - Hydrologic and Hydraulic Data Computations	A1-A16

PREFACE

This report is prepared under guidance contained in the Recommended Guidelines for Safety Inspection of Dams, for Phase I Investigations. Copies of these guidelines may be obtained from the Office of Chief of Engineers, Washington, D.C. 20314. The purpose of Phase I Investigation is to identify expeditiously those dams which may pose hazards to human life or property. The assessment of the general condition of the dam is based upon available data and visual inspections. Detailed investigation, and analyses involving topographic mapping, subsurface investigations, testing, and detailed computational evaluations are beyond the scope of a Phase I investigation; however, the investigation is intended to identify any need for such studies.

In reviewing this report, it should be realized that the reported condition of the dam is based on observations of field conditions at the time of inspection along with data available to the inspection team. It is important to note that the condition of a dam depends on numerous and constantly changing internal and external conditions, and is evolutionary in nature. It would be incorrect to assume that the present condition of the dam will continue to represent the condition of the dam at some point in the future. Only through continued care and inspection can there be any chance that unsafe conditions be detected.

Phase I inspections are not intended to provide detailed hydrologic and hydraulic analyses. In accordance with the established Guidelines, the Spillway Test flood is based on the estimated "Probable Maximum Flood" for the region (greatest reasonably possible storm runoff), or fractions thereof. The test flood provides a measure of relative spillway capacity and serves as an aid in determining the need for more detailed hydrologic and hydraulic studies, considering the size of the dam, its general condition and the downstream damage potential.

PHASE I INSPECTION REPORT
NATIONAL DAM INSPECTION PROGRAM
NAME OF DAM CEDAR LAKE DAM FED ID# NJ 00407

SECTION 1 - PROJECT INFORMATION

1.1 GENERAL

a. Authority

This report is authorized by the Dam Inspection Act, Public Law 92-367, and has been prepared in accordance with Contract FPM-36 between Louis Berger & Associates, Inc. and the State of New Jersey and its Department of Environmental Protection, Division of Water Resources. The State, in turn, is under agreement with the U.S. Army Engineer District, Philadelphia to have this inspection performed.

b. Purpose of Inspection

The purpose of this inspection is to evaluate the structural and hydraulic condition of the Cedar Lake Dam and appurtenant structures, and to determine if the dam constitutes a hazard to human life or property.

1.2 DESCRIPTION OF PROJECT

a. Description of Dam and Appurtenances

Cedar Lake Dam is a 40 year old earth roadway embankment approximately 410 feet in length with a vehicular bridge and spillway located about 150 feet from the east abutment. The embankment carries an access road used by maintenance vehicles from the east to the west shores of the recreation lake. The concrete spillway and superstructure have a clear span of 18 feet. The spillway overflow is a three-sided concrete drop inlet structure affixed to the south bridge fascia and has one wheel-operated sluice gate 2 feet wide by 3 feet high. The embankment has a finished concrete block wall along the entire upstream face to control erosion.

b. Location

Cedar Lake Dam is located 3,800 feet southwest of the intersection of Kresson Road (Route 671), Gibbsboro-Milford Road (Route 685) and State Highway 73, Voorhees Township, Camden County and is built across the Barton Run Tributary of the South Branch of the Rancocas Creek. It is one of a series of several small dams along this stream.

c. Size Classification

The maximum structural height of the dam is 13 feet at the spillway and the maximum storage is estimated to be 115 acre-feet. Therefore, the dam is placed in the small size category as defined by the Recommended Guidelines for Safety Inspection of Dams.

d. Hazard Classification

Based on the Corps of Engineers criteria and the fact that in the event of a failure, some moderate damage could be inflicted on downstream property, the classification of the dam is recommended to be downgraded to significant hazard. The immediate downstream floodplain is basically undeveloped. However, there are two lakes downstream (Lion and Kresson) and with the spillway of Kresson Lake immediately adjacent to the Route 73 roadway embankment and bridge structure, this creates a potential for an embankment washout or bridge failure in the event of an extreme flood or a series of dam breaks produced by the upper dams. Thus, a few lives could be endangered should there be passing traffic on this portion of Route 73.

e. Ownership

Cedar Lake Dam is owned by Mr. Herman Aducat, Kresson-Gibbsboro Road, Marlton, New Jersey.

f. Purpose of Dam

The dam was constructed to impound a recreation lake for a commercial amusement and summer recreational area.

g. Design and Construction History

Little information is known about the dam prior to its first recorded failure in September, 1940. This breaching washed away approximately 50 feet of the

embankment along with an existing timber spillway. The breaching was attributed to the failures of one or more smaller dams upstream. Because the failure meant the loss of revenue for the owner, steps for the reconstruction of the embankment were immediately undertaken. After incorporating design changes suggested by the State Engineer the spillway and embankment were reconstructed with the completion being in May, 1941 and final acceptance recommended in February 1942. The spillway design was accomplished by Mr. E. W. Bryant, P.E.

h. Normal Operating Procedures

No specific operating procedures are presently followed. However, the owner dewateres the lake each fall for cleaning and repairs of the docks and bulkheads of the amusement facilities and refills the lake each spring.

1.3 PERTINENT DATA

a. Drainage Area

The drainage area of Cedar Lake Dam is 3.0 square miles.

b. Discharge of Dam Site

The spillway capacity with the reservoir at the abutment top elevation is calculated to be approximately 1,304 cfs. No discharge records are available at this site. However, earlier dam applications indicate a design discharge of 700 cfs (see Section 5).

c. Elevation (Above M.S.L.)

Top of dam - 94.8
Recreation pool - 90.0 (Spillway crest)
Streambed at center line of dam - 82₊

d. Reservoir

Length of recreation pool - 600 feet
Length of maximum pool - 2,250 feet

e. Storage

Recreation pool - 40 acre-ft.
Top of dam - 115 acre-ft.

f. Reservoir Surface

Top of dam - 21 acres
Recreation pool - 9 acres

g. Dam

Type - Earth embankment with concrete spillway
Length - 410 feet
Height - 13 feet
Freeboard between normal reservoir and top of
dam - 4.8 feet
Top width - 12+ feet
Side slopes - 2H:1V
Zoning - composition and compactness unknown

h. Diversion and Regulating Tunnel

None

i. Spillway

Type - reinforced concrete drop inlet
Effective length of weir - 40 feet
Crest elevation - 90.0

j. Regulating Outlets

1 - 2'Wx3'H sluiceway

SECTION 2 - ENGINEERING DATA

2.1 DESIGN

Design information available for review were the 1941 construction drawings prepared by E.K. Bryant, P.E. of Mount Holly which are on microfilm file in the Division of Water Resources. Although no computations were located, the spillway structure is founded on untreated timber piling driven into the predominant recent alluvium and swampy soils which consist primarily of silt, sand and some clay. Below these lies the Kirkwood Sand formation, consisting of stratified deposits of marine origin having the general characteristics of a very fine micaceous quartz sand. The depth to bedrock is greater than 100 feet. The details of the footings, piling layout and reinforcing placement are clearly indicated on the plans.

2.2 CONSTRUCTION

The spillway structure and the repair to the embankment were constructed by William C. Smith, Contractor. Nothing is known about the earlier embankment that existed prior to the 1940 breaching. The 1941 reconstruction was closely monitored by State engineers who inspected the project weekly.

2.3 OPERATION

From statements made by the owner, and the appearance of the dam, it appears that the dam has functioned satisfactorily from an engineering standpoint since its reconstruction. There is no day-to-day operation although the lake is drained for over one-half of each year.

2.4 EVALUATION

a. Availability

In view of the size and hazard classification it is felt that sufficient engineering data is available except for the geotechnical composition of the embankment.

b. Adequacy

The original plans reveal that the spillway was carefully and conservatively designed and from the results of the field inspection, is built in accordance with the design plans. The data is deemed adequate for the analysis for this inspection.

c. Validity

Based on field observations, the validity of the 1941 design plans is not challenged but further investigations would be required to assess the permeability of the embankment and to verify the phreatic water levels in the lower portions of the backslopes.

SECTION 3 - VISUAL INSPECTION

3.1 FINDINGS

a. General

Visual inspections were conducted on November 21, 1979 and February 6, 1980 and revealed a stable structure which had been dewatered earlier in the fall. At the first inspection, discussions were held with the owner who accompanied the inspection team.

b. Dam

The overall structure is in generally good condition. The low concrete wall which has been constructed along the upstream shoreline stabilizes the 2H:1V slope which is well protected by a grassed area which contains several small trees. The embankment backslope is somewhat overgrown with brush and secondary growth (up to 24"). Several wet and spongy areas were observed on the left of the spillway (in the vicinity of the 1940 breaching) at the toe of the slope. In many areas, the top of the slope has been eroded to steep (75°+) angles with several trees and a telephone pole leaning downstream due to this surficial erosion. The low level seepage has triggered a sloughing of the downstream toe of the slope. The right downstream embankment appears in better condition and no evidence of seepage was noted.

The unpaved roadway crest is level and in satisfactory condition. In most areas, it is considerably wider than the 12' plan dimension.

The low concrete block protection along the face of the dam was positioned to stop wave action from the battering area on the right shoreline.

c. Appurtenant Structures

The hydraulic opening of the 3-sided concrete drop inlet appears adequate for handling normal flows but is somewhat restricted for larger design storms (as reviewed in Section 5). The exposed concrete is in satisfactory condition and most minor cracks and spalled areas have been patched. As the spillway is supported on timber piles, there is no differential settlement or major structural cracking. The low block wall along

the upstream shoreline frames into the spillway wingwalls and further protects the face of the dam from erosion.

The vehicular bridge deck over the spillway is in a sound integral condition and supports a low curb and chain link fencing on each facia which ties into similar fencing along the perimeter blockwall.

The wheel and low-level slide gate are in operable condition and appear satisfactorily maintained.

d. Reservoir Area

The man-made lake has well-defined shorelines which are protected in part by returns from the toe wall along the dam. The bathing beach area at the right abutment contains several pieces of swimming apparatus but most of the lake bottom is well graded and in a compact condition. Part abuts a golf course and the headwaters extend into a natural undisturbed swampy area.

e. Downstream Channel

The Barton Run flows less than 1,000 feet before entering Lion Lake, another small recreation pond. The channel is quite narrow (8-10 feet) and is partially blocked with fallen timber. Below Lion Lake, the run discharges into Kresson Lake just west of Route 73 and flows through a substandard culvert to the northeast.

SECTION 4 - OPERATIONAL PROCEDURES

4.1 PROCEDURES

Operational procedures were not physically observed by the inspection team although they were discussed with the owner during the November inspection.

4.2 MAINTENANCE OF DAM

Maintenance for the dam and spillway structure is handled by Mr. Aducat and maintenance employees of Cedar Lake Park and is performed continuously throughout the summer tourist season. As previously stated, the lake is dewatered from October through April thus allowing access to the spillway and concrete wall along the lake edge.

4.3 MAINTENANCE OF OPERATING FACILITIES

The only operating facility is the steel sluice gate which is well greased and in good operating condition.

4.4 DESCRIPTION OF WARNING SYSTEM IN EFFECT

None exists except for the continual monitoring by park personnel. The steel sluicgate is available to help control flooding, however, the owner stated that the need never has arisen to use the gate for that purpose.

4.5 EVALUATION

The present operations are deemed to be adequate in view of the height of the dam and the fact that there is no record of overtopping since 1940. The upkeep of the spillway and dam is adequate. In addition, the fact that the lake is dewatered for six months of every year reduces the possibility of flooding or failure.

SECTION 5 - HYDRAULIC/HYDROLOGIC

5.1 EVALUATION OF FEATURES

a. Design Data

Based on the criteria in the Recommended Guidelines for Safety Inspection of Dams, Cedar Lake dam is small in size and is placed in the significant hazard category. Accordingly, a 100-year frequency event was selected as the design storm and an inflow hydrograph calculated using precipitation data from Technical Paper 40 and NOAA Technical Memorandum NWS Hydro-35. Inflow to the reservoir was calculated utilizing the HEC-1 computer program, discharging a peak into the reservoir of 4,760 cfs. Routing this through the reservoir reduced the value slightly to 4,700 cfs. The spillway capacity before overtopping of the embankment is 1,304 cfs and is therefore able to accommodate only 28% of the design flood.

b. Experience Data

Division of Water Resources records state that the spillway and a portion of the embankment washed out in September, 1940. The new spillway was constructed for a design flow of 700 cfs at a head of three feet and this capacity has apparently proved sufficient to date.

c. Visual Observations

There is no evidence of any problem concerning overtopping; however, the lake was in a dewatered condition at the time of inspection.

d. Overtopping Potential

The appended hydraulic analysis indicates a considerable potential exists for overtopping, due primarily to the limited spillway capacity. The design flood would overtop the dam crest by approximately 1.8 feet.

e. Drawdown Potential

Utilizing the 2'x3' sluiceway in the main face of the spillway, it would take approximately 30 hours to dewater the lake.

SECTION 6 - STRUCTURAL STABILITY

6.1 EVALUATION OF STRUCTURAL STABILITY

a. Visual Observations

Based upon the existing conditions inspected in the field and review of the 1941 spillway construction plans, the dam is judged to be in a relatively good condition except for the erosion and irregularity of the downstream slopes to the left of the spillway. The embankment is quite wide with respect to its height and accordingly, its stability is adequate in the opinion of the inspection team. Some seepage was noted in the natural downstream terrain immediately below the embankment. The concrete spillway is in satisfactory condition and is constructed on timber piling. The steel sluice gate is operable and in a well maintained condition.

b. Design & Construction History

Although no design computations were available, the concrete spillway structure is of modest span and height and displays only minor cracking after 40 years of service. Its structural stability, in spite of its age, is satisfactory. The low toewall at the lake shore edge of the upstream slope has no structural effect upon the dam but helps stabilize the toe of the sloped surface.

c. Operating Records

No records are available but the drop inlet sluiceway operates satisfactory for normal flows. There is no record of any overtopping since 1940.

d. Post Construction Changes

The only post construction changes since the 1941 widening and reconstruction have been the addition and modification of the roadway appurtenances and the addition of the low seawall and sidewalk along the upstream face. The crest roadway drainage appears to be a continual maintenance problem but is presently causing only minor erosion to the dam face and can easily be repaired.

e. Seismic Stability

Cedar Lake Dam is located in Seismic Zone 1 and due to its large width to height ratio has adequate stability under dynamic loadings as it is stable under static loading conditions.

SECTION 7 - ASSESSMENTS/RECOMMENDATIONS/
PROPOSED REMEDIAL MEASURES

7.1 DAM ASSESSMENT

a. Safety

Subject to the inherent limitations of the Phase I visual inspection, the Cedar Lake Dam is classified as being in a good overall structural condition although the spillway is incapable of passing the design flood. The embankment is built of unknown composition. However, with the possible exception of the area to the left of spillway, the embankment is believed to be of a sufficient impermeable condition due to its width to height ratio to withstand all normally anticipated hydraulic heads. The present spillway capacity is inadequate and does not meet the requirements of the Recommended Guidelines for Safety Inspection of Dams, being able to accommodate 28% of the design flood as calculated by Corps of Engineers criteria. However, the calculated SDF would overtop the dam by only slightly more than 1.8 feet at the low point of the dam crest and except for the probable erosion of the downstream face, it is felt that little other damage would occur should the crest be overtopped.

b. Adequacy of Information

The information gathered for the Phase I inspection is deemed to be adequate regarding structural stability. However, no recent surveys have been made and recorded performance information is non-existent. The dam has apparently never been inspected by the Division of Water Resources since the 1941 reconstruction.

c. Urgency

No urgency is attached to implementing further studies. It is recommended that the remedial measures enumerated below be accomplished in the future.

d. Necessity for Further Study

Due to the significant hazard classification and the present spillway capacity, engineering studies, under the purview of P.L. 92-367, are believed necessary to ascertain more precisely the hydraulic conditions. It is further recommended that Division of Water Resources personnel reinspect the dam during dry weather in the summer months to further ascertain the sloughing and spongy conditions below the left abutment zone.

7.2 RECOMMENDATIONS/REMEDIAL MEASURES

a. Recommendations

On the basis of the visual inspection, improvements to the principal spillway are not warranted until the hydraulic studies mentioned in the preceding paragraph are completed. The downstream embankment areas at the ends of the culvert wingwalls should be regraded and protected. Other remedial measures to be taken under advisement include:

- 1) removal of the trees, brush and major root systems on the downstream embankment to lessen the piping potential
- 2) Backfill and regrade the downstream backslopes and seed the repaired areas.

b. O&M Maintenance and Procedures

In the near future the owner should develop written operating procedures and a periodic maintenance plan to insure the safety of the dam. Additionally, the owner should develop an emergency action plan commensurate with the hazard conditions which would outline actions to lessen downstream effects during an emergency.

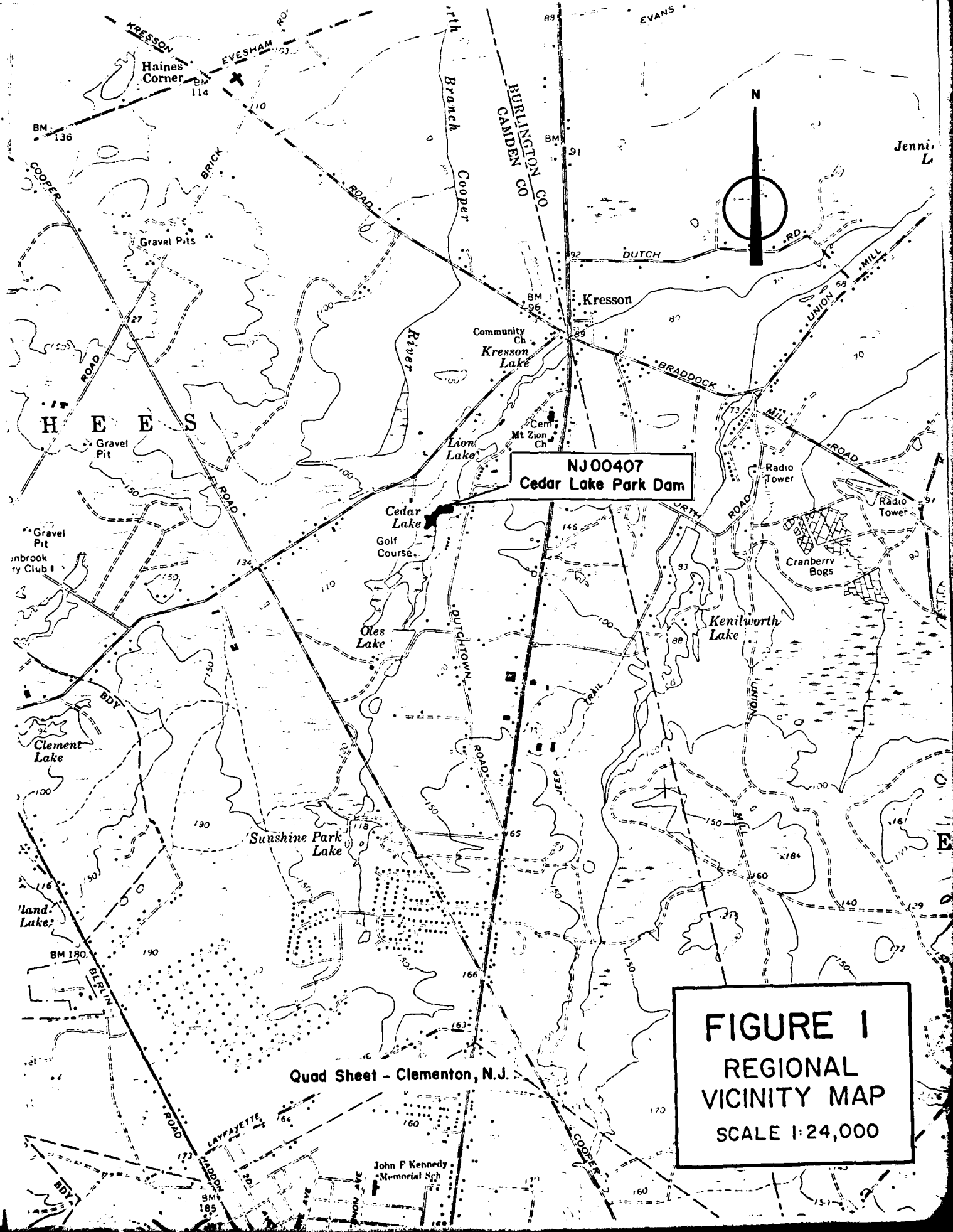

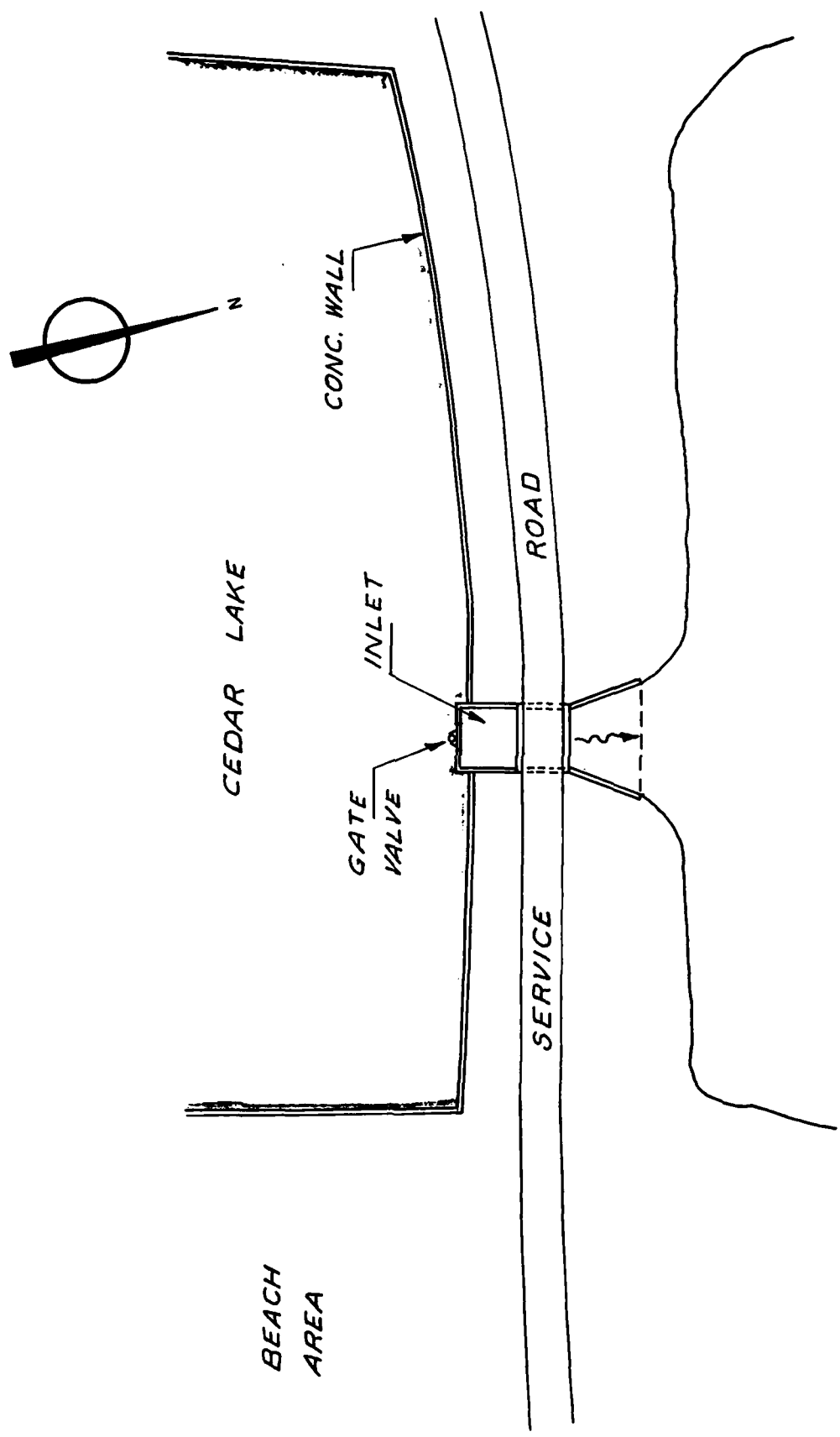

PLAN
NOT TO SCALE

FIGURE 2

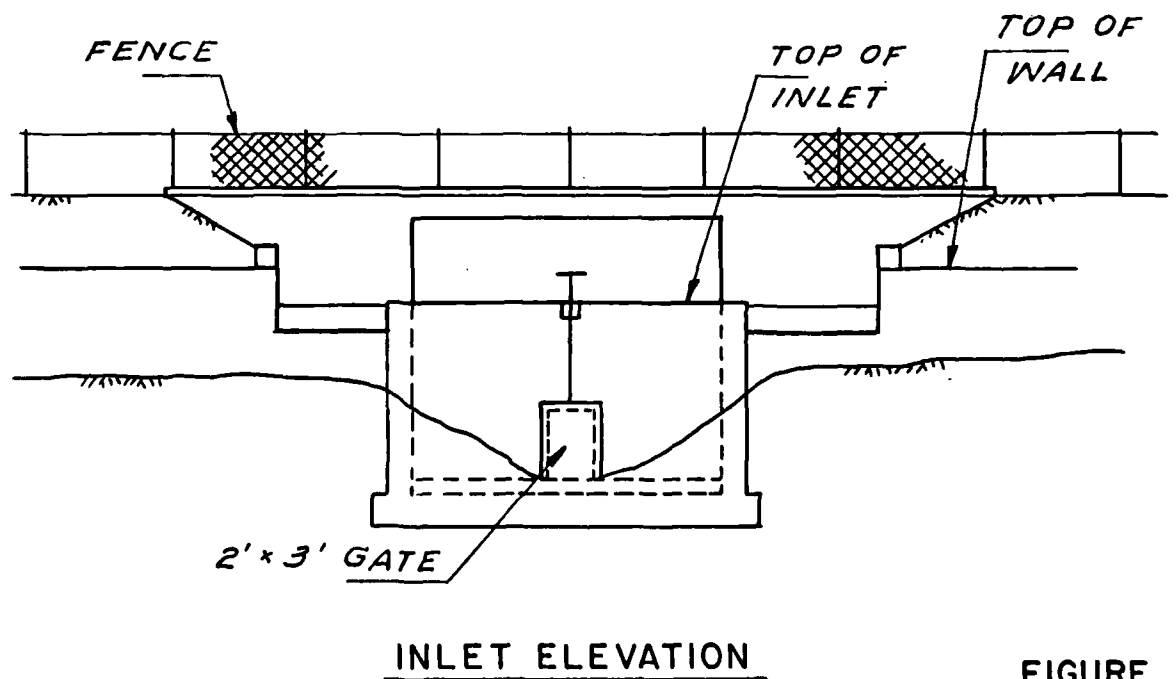
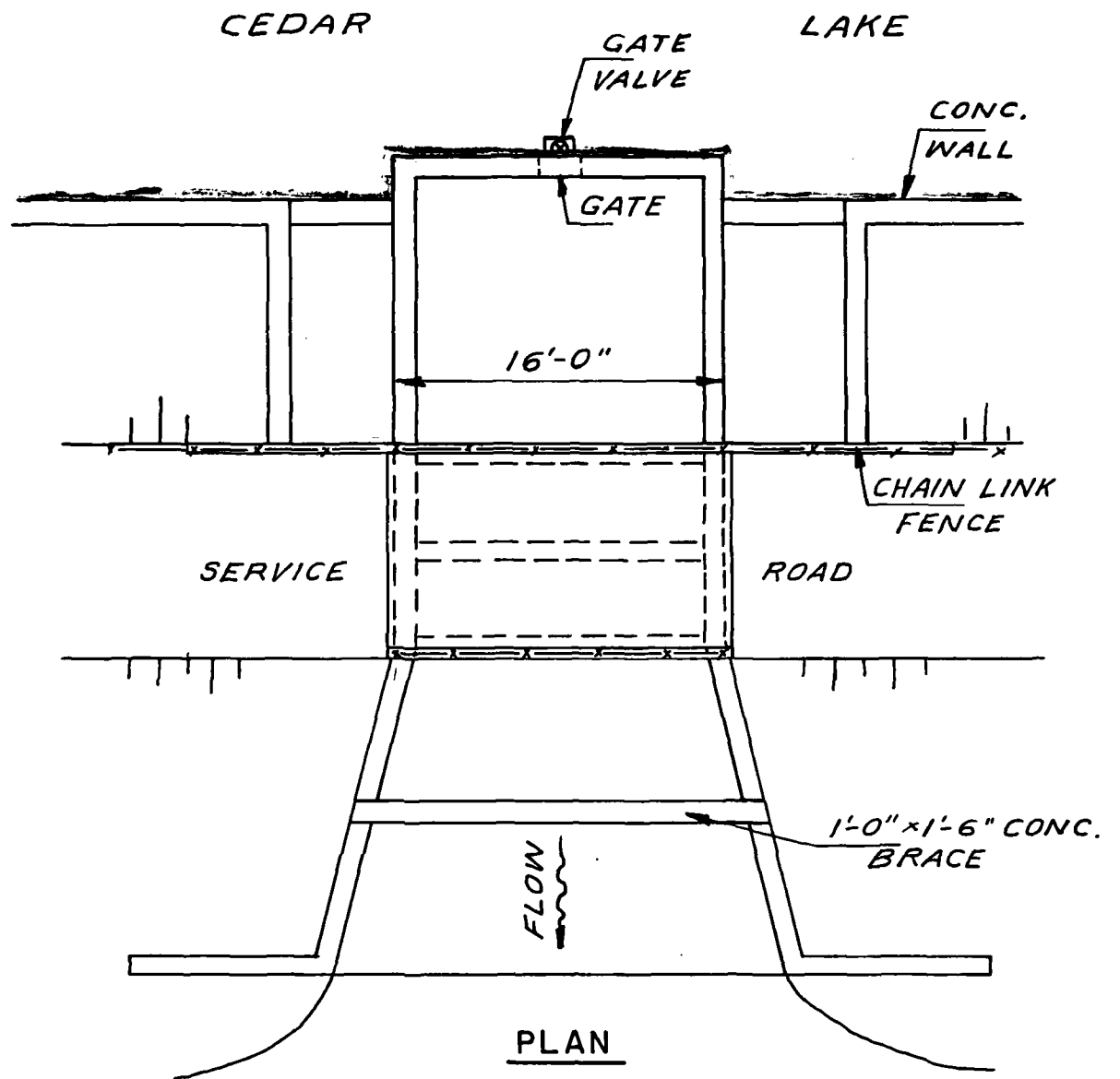
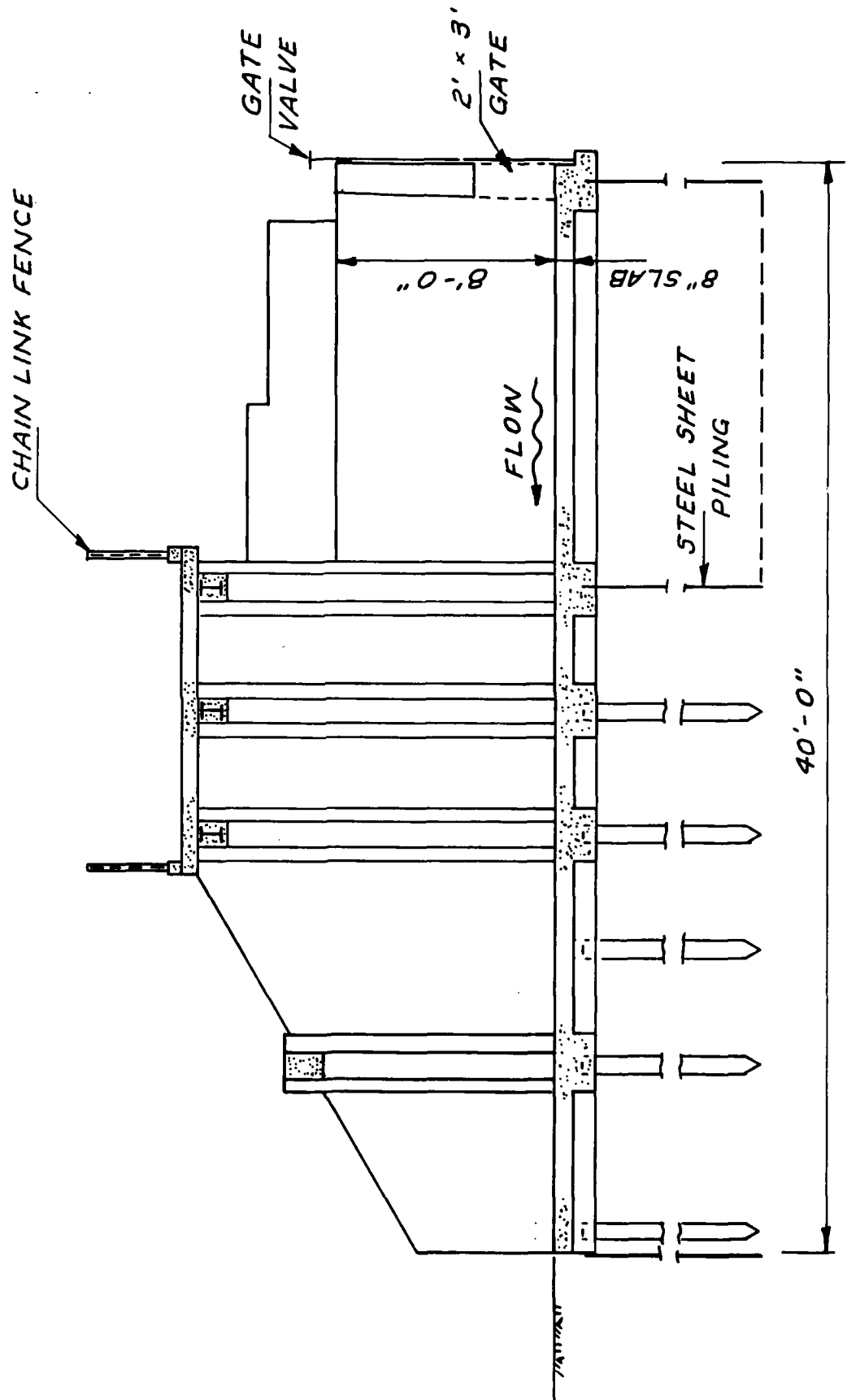

FIGURE 3



SECTION THRU SPILLWAY
NOT TO SCALE

FIGURE 4

Check List
Visual Inspection
Phase I

Name Dam Cedar Lake County Camden State New Jersey Coordinators NJDEP

Date(s) Inspection 11-21-79 Weather Sunny Temperature 60°

2-6-80

Pool Elevation at Time of Inspection 82.5 M.S.L. Tailwater at Time of Inspection 82.5 M.S.L.
(dewatered)

Inspection Personnel:

R. Lang L. Baines K. Jolls

J. Voorhees Herman Aducat (owner)

E. Simone

R. Lang Recorder

SHEET 1

CONCRETE/MASONRY DAMS

VISUAL EXAMINATION OF	OBSERVATIONS	REMARKS OR RECOMMENDATIONS
-----------------------	--------------	----------------------------

SEE PAGE ON LEAKAGE

STRUCTURE TO
ABUTMENT/EMBANKMENT
JUNCTIONS

Good, no differential elevation
or surface cracks noticed.

DRAINS

None

WATER PASSAGES

Lift gate in center spillway.

3'x2' wheel operated.

FOUNDATION

See plans, probable timber piling.

CONCRETE/MASONRY DAMS

VISUAL EXAMINATION OF	OBSERVATIONS	REMARKS OR RECOMMENDATIONS
SURFACE CRACKS CONCRETE SURFACES	Minor cracking at NE wingwall, rebar exposed hand troweled patches on wall surfaces.	
STRUCTURAL CRACKING	None observed - concrete structure in good condition.	
VERTICAL AND HORIZONTAL ALIGNMENT	Good alignment, roadway bridge deck. Structure in overall good condition.	
MONOLITH JOINTS	Satisfactory	
CONSTRUCTION JOINTS	Satisfactory	

EMBANKMENT

VISUAL EXAMINATION OF	OBSERVATIONS	REMARKS OR RECOMMENDATIONS
SURFACE CRACKS	Embankment in good condition. Concrete block wall said to be placed for wave protection 6" freeboard when lake is up to top of concrete wall upstream another 4' to top of roadway	
UNUSUAL MOVEMENT OR CRACKING AT OR BEYOND THE TOE	Backslope 150' west of spillway is near vertical, much sloughing.	Backfill and regrade. Seed repaired areas.
SLOUGHING OR EROSION OF EMBANKMENT AND ADJACENT SLOPES	Embankment on downstream slope is heavily wooded, upstream side is spongy to walk on. Downstream toe has possible seepage, erosion due to surface runoff appears to be some problem.	
VERTICAL AND HORIZONTAL ALIGNMENT OF THE CREST	Good, roadway embankment, sand material.	
RIPRAP FAILURES	None evident.	

EMBANKMENT

VISUAL EXAMINATION OF	OBSERVATIONS	REMARKS OR RECOMMENDATIONS
-----------------------	--------------	----------------------------

JUNCTION OF EMBANKMENT
AND ABUTMENT, SPILLWAY
AND DAM

Good, embankment stabilized with good grass cover on upstream, downstream west embankment are subject to question, downstream east side slopes are fairly good, less sloughing.

ANY NOTICEABLE SEEPAGE

Lake dewatered, downstream toe quite spongy though.

Lake must be reinspected with water level up to recreation pool.

STAFF GAGE AND RECORDER

None

DRAINS

None

OUTLET WORKS

VISUAL EXAMINATION OF

**CRACKING AND SPALLING OF
CONCRETE SURFACES IN
OUTLET CONDUIT**

No spalling evident

OBSERVATIONS

REMARKS OR RECOMMENDATIONS

INTAKE STRUCTURE

Good condition.

OUTLET STRUCTURE

Bridge structure 360' long. Built in conjunction with spillway.

OUTLET CHANNEL

Natural channel, heavily wooded low lying floodplain.

EMERGENCY GATE

Lift gate.

UNGATED SPILLWAY

VISUAL EXAMINATION OF	OBSERVATIONS	REMARKS OR RECOMMENDATIONS
CONCRETE WEIR	<p>Three sided over flow weir 40' long See plans for dimension breakdown.</p>	<p>Side weir troughs should have debris removed.</p>
APPROACH CHANNEL	<p>Cedar Lake - open and clear</p>	
DISCHARGE CHANNEL	<p>Natural channel (see downstream channel section).</p>	
BRIDGE AND PIERS	<p>Bridge integral part of spillway and embankment.</p>	

①

GATED SPILLWAY

VISUAL EXAMINATION OF	OBSERVATIONS	REMARKS OR RECOMMENDATIONS
CONCRETE SILL	N/A	
APPROACH CHANNEL	N/A	
DISCHARGE CHANNEL	N/A	
BRIDGE AND PIERS	N/A	
GATES AND OPERATION EQUIPMENT	Wheel operated lift gate, good condition.	



RESERVOIR

VISUAL EXAMINATION OF

OBSERVATIONS

REMARKS OR RECOMMENDATIONS

SLOPES

Very gentle slopes, beach area on all sides.

SEDIMENTATION

Yes, silting up about upstream face of embankment.

DOWNSTREAM CHANNEL

VISUAL EXAMINATION OF

OBSERVATIONS

REMARKS OR RECOMMENDATIONS

**CONDITION
(OBSTRUCTIONS,
DEBRIS, ETC.)**

Natural meandering channel, heavily wooded 8-10' wide

SLOPES

Low lying flood plain.

**APPROXIMATE NO.
OF HOMES AND
POPULATION**

Few on east side, appear to be above floodplain.

CHECK LIST
ENGINEERING DATA
DESIGN, CONSTRUCTION, OPERATION

ITEM	REMARKS
PLAN OF DAM	Available - NJDEP - Div. of Water Resources - Bureau of Flood Plain Management Trenton, New Jersey
REGIONAL VICINITY MAP	Available - USGS Quad - New Jersey
CONSTRUCTION HISTORY	Available - 1941 reconstruction (NJDEP)
TYPICAL SECTIONS OF DAM	Available (NJDEP)
HYDROLOGIC/HYDRAULIC DATA	None available
OUTLETS - PLAN	Available (NJDEP)
- DETAILS	Available (NJDEP)
-CONSTRAINTS	Not available
-DISCHARGE RATINGS	Available (NJDEP)
RAINFALL/RESERVOIR RECORDS	None

ITEM _____ REMARKS _____

SPILLWAY PLAN Available (NJDEP)

SECTIONS " "

DETAILS " "

OPERATING EQUIPMENT
PLANS & DETAILS None available

ITEM

REMARKS

DESIGN REPORTS

None available

GEOLOGY REPORTS

None available

DESIGN COMPUTATIONS
HYDROLOGY & HYDRAULICS
DAM STABILITY
SEEPAGE STUDIES

Some available (1941 Reconstruction) (NJDEP)
None available
Available (NJDEP)
None available

MATERIALS INVESTIGATIONS
BORING RECORDS
LABORATORY
FIELD

Not available
"
"
"

POST-CONSTRUCTION SURVEYS OF DAM

Not available

BORROW SOURCES

Unknown

ITEM _____ REMARKS _____

MONITORING SYSTEMS None

MODIFICATIONS Not since 1941 Reconstruction

HIGH POOL RECORDS None available

POST CONSTRUCTION ENGINEERING None
STUDIES AND REPORTS

PRIOR ACCIDENTS OR FAILURE OF DAM September 1940
DESCRIPTION Available (NJDEP)
REPORTS None

MAINTENANCE None available
OPERATION
RECORDS

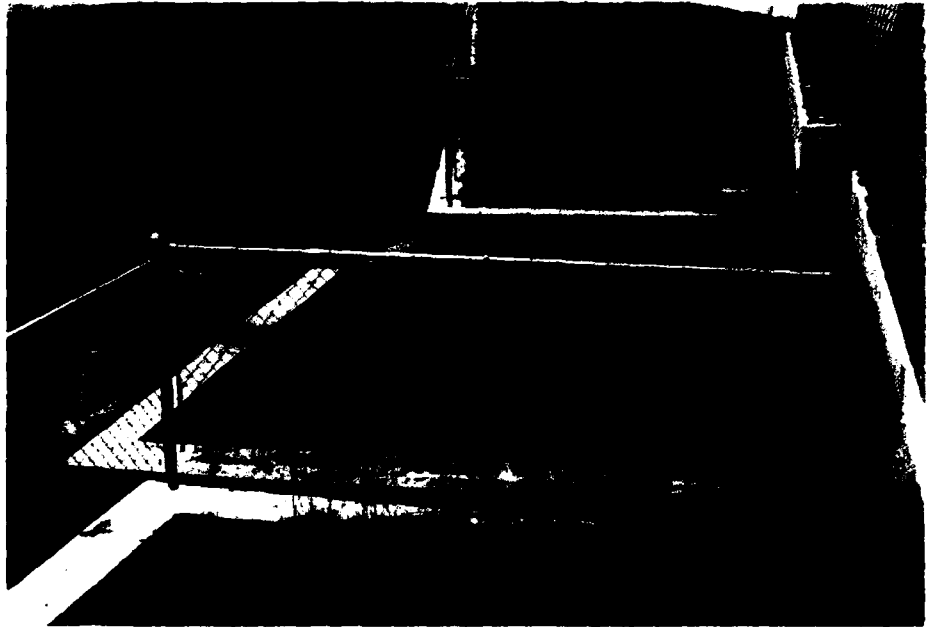

February, 1980

View of Spillway

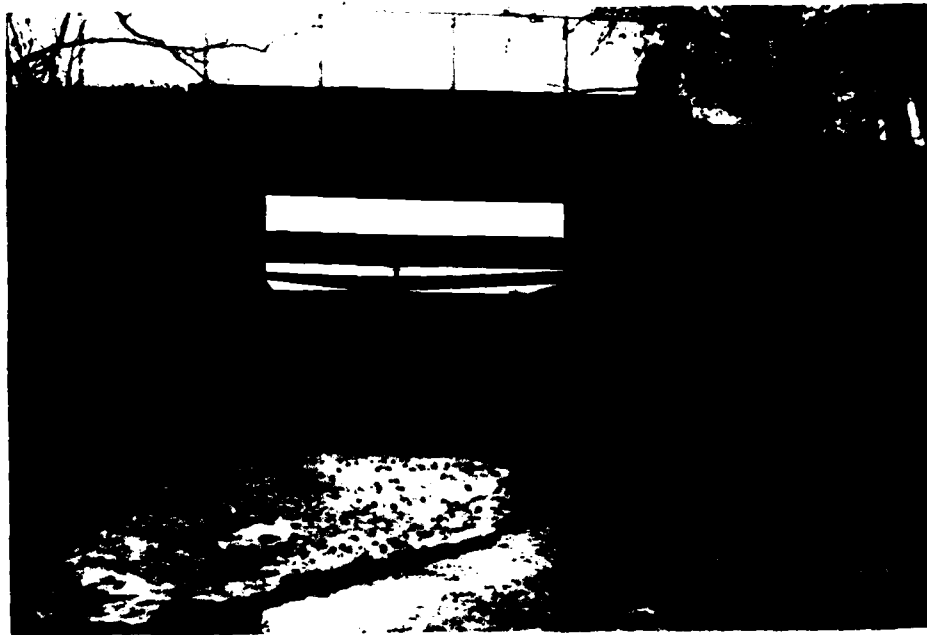

February, 1980

Downstream View of Spillway



November, 1979

View of Downstream Slope of
Right Embankment



November, 1979

View of Slide Gate



November, 1979

View of Crest Looking East



November, 1979

View Upstream

CHECK LIST
HYDROLOGIC AND HYDRAULIC DATA
ENGINEERING DATA

DRAINAGE AREA CHARACTERISTICS: 3.0 square miles

ELEVATION TOP NORMAL POOL (STORAGE CAPACITY): +90.0 MSL (40 acre-ft.)

ELEVATION TOP FLOOD CONTROL POOL (STORAGE CAPACITY): _____

ELEVATION MAXIMUM DESIGN POOL: _____

ELEVATION TOP DAM: +94.8 MSL (111 acre-feet)

CREST: _____

- a. Elevation +94.8 MSL
- b. Type Earth embankment with concrete spillway
- c. Width 12'±
- d. Length 410'
- e. Location Spillover 150' from east end
- f. Number and Type of Gates _____

OUTLET WORKS: _____

- a. Type Three sided concrete box
- b. Location 150' from east end
- c. Entrance inverts +90.0 MSL
- d. Exit inverts +82.0 MSL
- e. Emergency draindown facilities 1 - 3'x2' sluiceway

HYDROMETEOROLOGICAL GAGES: None

- a. Type _____
- b. Location _____
- c. Records _____

MAXIMUM NON-DAMAGING DISCHARGE: 1,304 cfs

BY L. B. DATE 5-80
CHKD. BY _____ DATE _____
SUBJECT _____

LOUIS BERGER & ASSOCIATES INC.

SHEET NO. A1 OF _____
PROJECT C-246

TIME OF CONCENTRATION :

LENGTH ALONG WATERCOURSE TO DRAINAGE DIVIDE = 11,000 FT
= 2.08 MI

$$\Delta H = 190' - 90' = 100 \text{ FT}$$

$$\text{SLOPE} = \frac{100 \times 100}{11,000} \approx 1\% \quad \text{ASSUME VELOCITY} = 2 \text{ FT/SEC}$$

$$t_c = \frac{11,000}{2 \times 3600} = 1.53 \text{ HRS}$$

BY CALIFORNIA CULVERTS METHOD

$$t_c = \left(\frac{11.9 L^3}{H} \right)^{0.385} = \left[\frac{11.9 (2.03)^3}{100} \right]^{0.385} = 1.03 \text{ HRS}$$

BY SCS METHOD (FROM URBAN HYDROLOGY FOR SMALL WATERSHEDS
TECHNICAL RELEASE NO. 55)

ASSUME CN FOR WATERSHED = 78

SLOPE = 1%

L = 11,000 FT

USING NOMOGRAM (FIG. 3.3) FOR $L = \frac{2^{0.8} (S+1)^{0.7}}{1500 Y^{0.5}}$

L = 2.5 HRS

L = LAG IN HOURS

$$\therefore t_c = \frac{\text{LAG}}{0.6} = \frac{2.5}{0.6} = 4.2 \text{ HRS} \quad (\text{High})$$

USE $t_c = 1.20 \text{ HRS}$

$$T_p = \frac{D}{2} + 0.6 t_c \quad T_p = \frac{0.25}{2} + 0.6 (1.2) = 0.88$$

BY RFB DATE 1-14-50
 CHKD. BY _____ DATE _____
 SUBJECT _____

LOUIS BERGER & ASSOCIATES INC.
CEDAR LAKE DAM

SHEET NO. A2 OF _____
 PROJECT _____

$$Q_p = \frac{484 A (1)}{T_p} = \frac{484 (3.0) (1)}{0.88} = 1650 \text{ CFS}$$

UNIT GRAPH TIME HOURS	T/T _p	DIMENSIONLESS ORDINATE (D.O.)	Q (CFS) Q _p x D.O.
0.25	0.28	0.140	231
0.50	0.57	0.547	902
0.75	0.85	0.932	1539
1.00	1.17	0.940	1551
1.25	1.42	0.732	1208
1.50	1.70	0.480	792
1.75	1.99	0.324	535
2.00	2.27	0.213	360
2.25	2.56	0.138	228
2.50	2.84	0.093	152
2.75	3.12	0.062	104
3.00	3.41	0.041	68
3.25	3.69	0.0282	47
3.50	3.98	0.0182	30
3.75	4.26	0.012	20
			<u>Σ = 7768</u>

CHECK

$$\frac{7768 \times 12 \times 3600}{4 \times 3.0 \times 5280^2} = 1.0031 \approx 1 \text{ INCH}$$

BY L. B. DATE 5-80

LOUIS BERGER & ASSOCIATES INC.

SHEET NO. A3 OF

CHKD. BY _____ DATE _____ CECAP LAKE DAM

PROJECT C-246

SUBJECT TEST STORM 8 100 YR FREQUENCY

PRECIPITATION DATA FROM TP-40 E NOAA TECHNICAL
MEMORANDUM NWS HYDRO-35 (DISTRIBUTION FROM COE)

TIME	PRECIPITATION	Δ	REARRANGE Δ
0.25	1.7	1.7	0.06
0.50	2.4	0.7	0.06
0.75	2.8	0.4	0.06
1.00	3.1	0.3	0.06
1.25	3.4	0.3	0.07
1.50	3.7	0.3	0.07
1.75	3.86	0.16	0.08
2.00	4.00	0.14	0.09
2.25	4.11	0.11	0.14
2.50	4.22	0.11	0.16
2.75	4.31	0.09	0.3
3.00	4.40	0.09	0.3
3.25	4.49	0.09	0.3
3.50	4.57	0.08	0.7
3.75	4.64	0.07	1.70
4.00	4.71	0.07	0.4
4.25	4.78	0.07	0.11
4.50	4.84	0.06	0.11
4.75	4.89	0.06	0.09
5.00	4.96	0.06	0.09
5.25	5.02	0.06	0.07
5.50	5.08	0.06	0.06
5.75	5.14	0.06	0.06
6.00	5.20	0.06	0.06

BY RFB DATE 1-14-80 **LOUIS BERGER & ASSOCIATES INC.** SHEET NO. A4 OF
 CHKD. BY DATE CEDAR LAKE DAM PROJECT
 SUBJECT SPILLWAY ANALYSIS

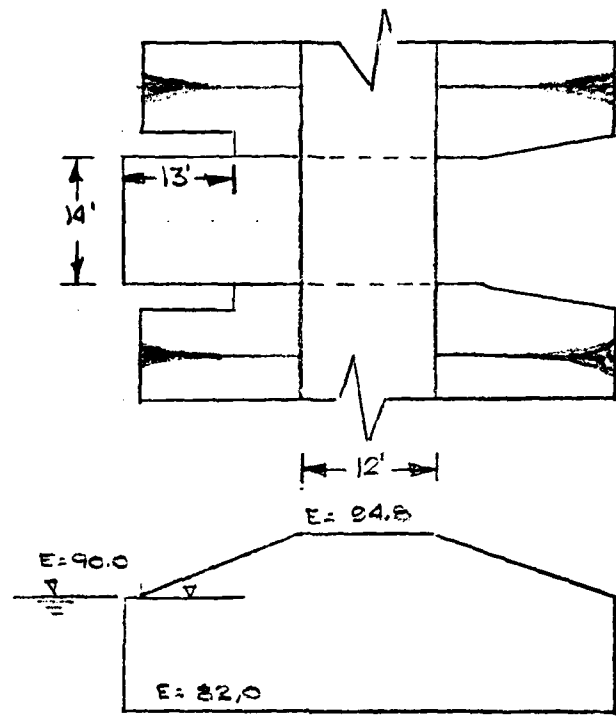

H	SPILLWAY			EMBANKMENT			Σ Q	ELEV FT	
	C	L	Q	H	C	L			Q
0.5	3.1	4.0	44	0	2.6	42E	0	45	90.5
1	↓	↓	124	0	↓	↓	0	125	91
1.5	↓	↓	226	0	↓	↓	0	230	91.5
2	↓	↓	351	0	↓	↓	0	350	92
3	↓	↓	644	0	↓	↓	0	645	93
4	↓	↓	992	0	↓	↓	0	990	94
4.8	↓	↓	1304	0	↓	↓	0	1300	94.8
5	↓	↓	1836	.2	↓	↓	99	1435	95
6	↓	↓	1802	1.2	↓	↓	1452	3275	96
7	↓	↓	2296	2.2	↓	↓	3606	5900	97
8	↓	↓	2806	3.2	↓	↓	6325	9130	98

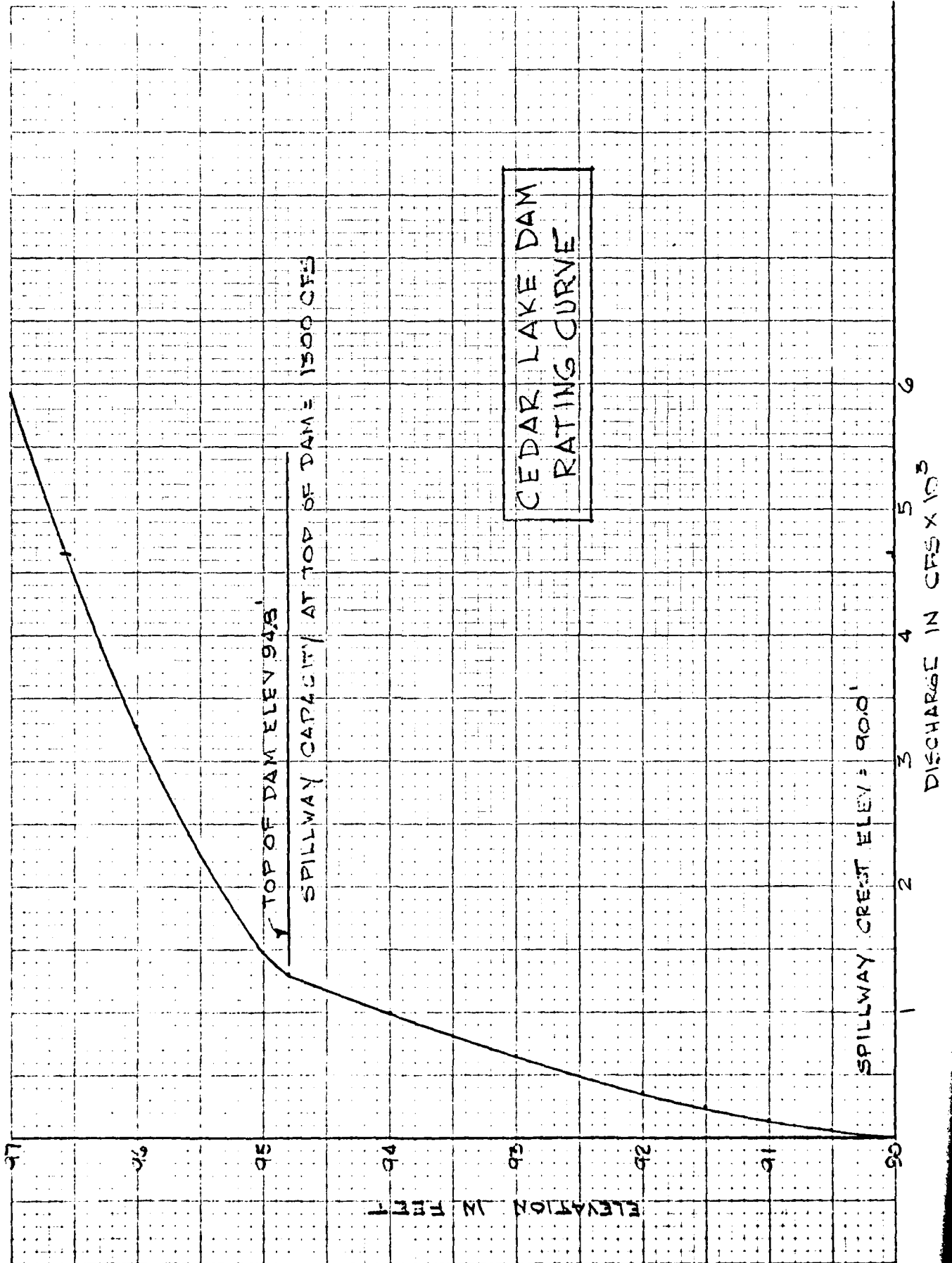

BY RFB DATE 1-14-50 **LOUIS BERGER & ASSOCIATES INC.** SHEET NO. A6 OF
 CHKD. BY DATE CEDAR LAKE DAM PROJECT
 SUBJECT SURCHARGE STORAGE

AREA OF LAKE @ ELEV 90.0 = 9.0 ACRES

AREA @ 100 FT CONTOUR = 33.1 ACRES

ASSUME POOL ABOVE 100 FT CONTOUR PROJECTS
 AT SAME RATE

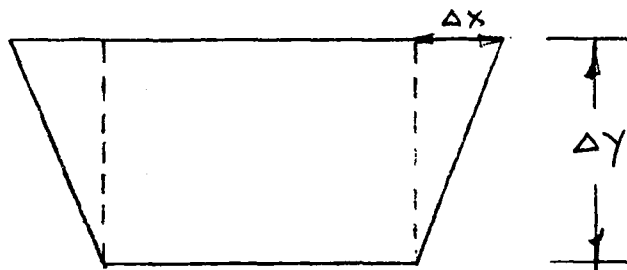

$$\Delta y^2 = \Delta y (x + \Delta x)$$

HEIGHT ABOVE SPILLWAY CREST	AREA ACRES	SURCHARGE STORAGE ACR.-FT
0	9	0
1	11.4	10
2	13.6	22
3	16.2	36
4	18.6	55
5	21.0	75
6	23.5	97
7	25.1	122
8	28.2	149
9	30.7	179
10	33.1	210

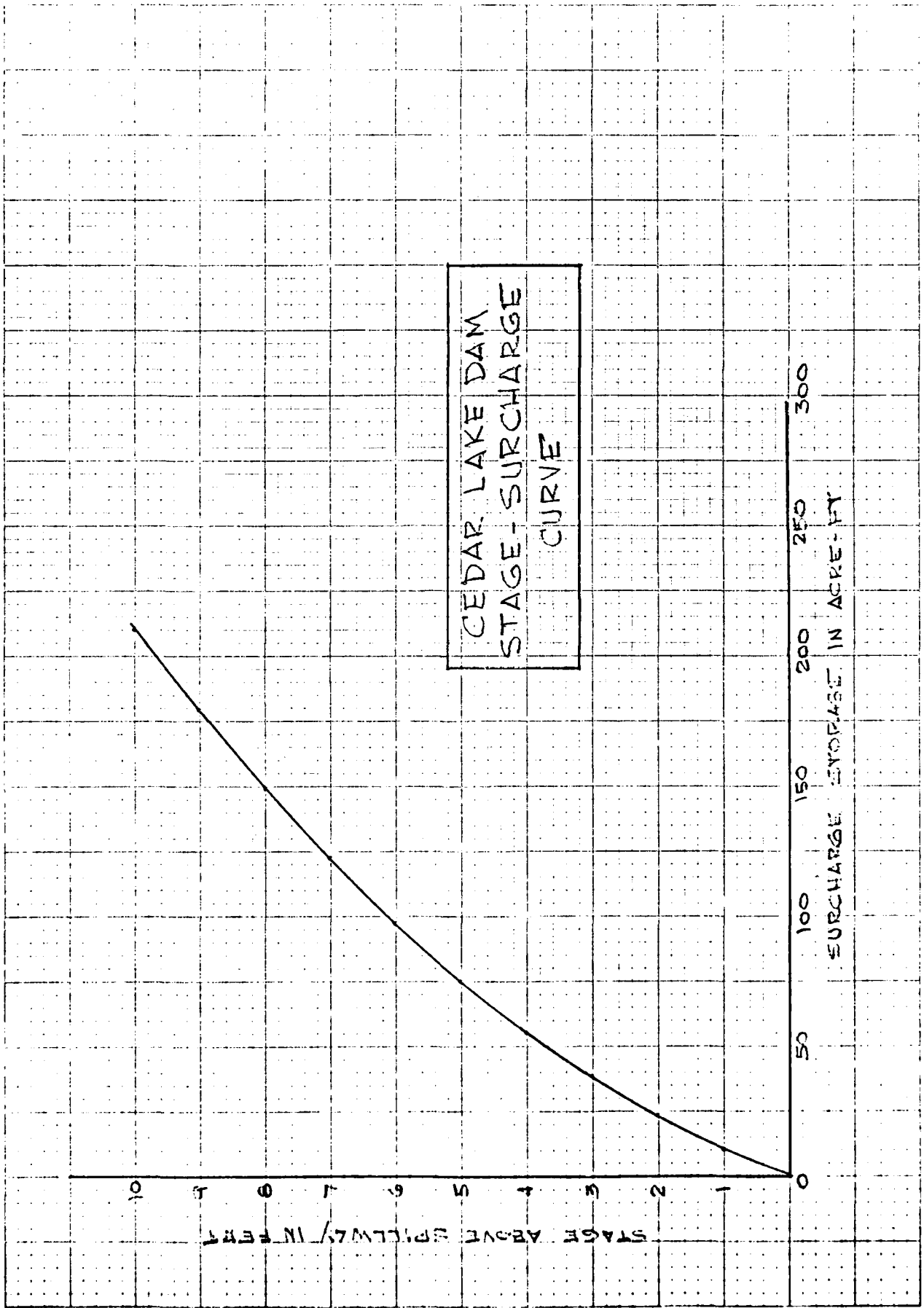

CEDAR LAKE DAM
STAGE - SURCHARGE
CURVE

BY J.E. DATE 5-80

LOUIS BERGER & ASSOCIATES INC.

SHEET NO. 18 OF

CHKD. BY _____ DATE _____

CHEMICAL WASTE PAPER

PROJECT C-2/H2

SUBJECT DRAWDOWN CALCULATIONS

LOW LEVEL OUTLET - RECTANGULAR SLUICE
SIZE: 3' HIGH x 2' WIDE = 6 SQ. FT.

ASSUME AN INFLOW OF 3 CFS

ASSUME DRAWDOWN IN 3 STAGES

STAGE 1

$$H = 4.5$$

$$Q = CA^{1/2} \sqrt{2gH} \quad C = 0.5; A = 6 \text{ SQ. FT.}$$

$$Q = 0.5(6) \sqrt{64.4(4.5)}$$

$$= 51.3$$

$$= 48 \text{ CFS}$$

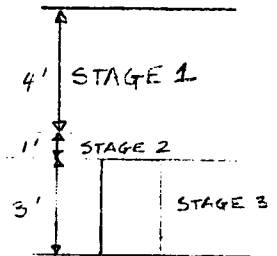

$$\Delta \text{ TIME}_{\text{STAGE 1}} = \frac{42560 \times 40}{2 \times 48 \times 3600}$$

$$= 5 \text{ HRS}$$

STAGE 2

$$H = 2'$$

$$Q = 0.5(6) \sqrt{64.4(2)}$$

$$= 24 \text{ CFS} - 3 \text{ CFS}$$

$$= 21 \text{ CFS}$$

$$\Delta \text{ TIME}_{\text{STAGE 2}} = \frac{42560 \times 40}{8 \times 21 \times 3600}$$

$$= 2 \text{ HRS}$$

STAGE 3

$$H = 1.5' \quad (\text{WEIR FLOW})$$

$$Q = 2(2.1)(1.5)^{3/2} \quad C = 3.1 \quad L = 2'$$

$$Q = 11.3$$

$$= 8 \text{ CFS}$$

$$\Delta \text{ TIME}_{\text{STAGE 3}} = \frac{42560 \times 40 \times 3}{3 \times 8 \times 3600} = 23 \text{ HRS}$$

$$\text{TOTAL TIME} = 5 + 2 + 23 = 30 \text{ HRS}$$

BY RFB DATE 1-14-50 LOUIS BERGER & ASSOCIATES INC.

CHKD. BY DATE CEDAR LAKE DAM

SHEET NO. A9 OF

PROJECT C-246

SUBJECT

COMPUTER 1/2 & 1/3 CARDS INPUT DATA
FROM COMPUTATIONS AND CURVES

STAGE OVER SPILLWAY CREST	Q CFS	SURCHARGE ACRE-FT
0	0	0
1	125	10
2	350	22
3	645	38
4	990	55
4.8	1300	71
5	1485	75
6	3075	97
7	5900	122
8	9120	149

 HEC-1 VERSION DATED JAN 1973
 UPDATED AUG 74
 CHANGE NO 01

 CEDAR LAKE DAM
 R.F. BERRY
 MAY, 1980

JOB SPECIFICATION
 NG NHR NMIN IDAY IHR IMIN METRC IPLT IPRT NSTAN
 100 0 15 0 0 0 0 0 0 0 0
 JOPER 0 NJT
 3 0

SUB-AREA RUNOFF COMPUTATION

INFLOW TO RESERVOIR
 I1STAG 1
 ICOMP 0
 IECON 0
 ITAPE 0
 JPLT 0
 JPRRT 0
 INAME 1

INHYDG	IUNG	TAREA	SNAP	TRSDA	TRSPC	RATIO	ISNOW	ISAME	LOCAL
0	-1	3.00	0.00	3.00	0.00	0.000	0	0	0
0.06	0.06	0.06	0.06	0.07	0.07	0.07	0.08	0.09	0.14
0.30	0.30	0.30	0.70	1.70	0.40	0.11	0.11	0.11	0.09
0.07	0.06	0.06	0.06						0.09

PRECIP DATA
 NP STDRM DAK
 24 0.00 0.00
 PRECIP PATTERN
 0.07 0.07
 1.70 0.40

LOSS DATA
 STRKS RTIOK STRTL
 0.00 1.00 0.50

STRKR	DLTKR	RTIOK	ERAIN	STRTL	CNSTL	ALSMX	RTIMP
0.00	0.00	1.00	0.00	0.50	0.10	0.00	0.00
902	1539	47	1551	15	535	360	228
104	68	30	792	153			

UNIT GRAPH TOTALS 7768. CFS OR 1.00 INCHES OVER THE AREA
 RECESION DATA
 STRTG= 0.00 GRCSN= 0.00 RTIOR= 1.00

END-OF-PERIOD FLOW
 TIME RAIN EXCS COMP Q
 1 0.06 0.00 0.
 2 0.06 0.00 0.
 3 0.06 0.00 0.

4	0.06	0.00	0.
5	0.07	0.00	0.
6	0.07	0.00	0.
7	0.08	0.00	0.
8	0.09	0.04	8.
9	0.14	0.12	59.
10	0.16	0.13	190.
11	0.30	0.27	418.
12	0.30	0.27	741.
13	0.30	0.27	1112.
14	0.70	0.67	1527.
15	1.70	1.67	2359.
16	0.40	0.38	3735.
17	0.11	0.08	4760.
18	0.11	0.08	4603.
19	0.09	0.07	3706.
20	0.09	0.07	2704.
21	0.07	0.04	1989.
22	0.06	0.03	1477.
23	0.06	0.03	1088.
24	0.06	0.03	824.
25	0.00	0.00	634.
26	0.00	0.00	475.
27	0.00	0.00	338.
28	0.00	0.00	226.
29	0.00	0.00	141.
30	0.00	0.00	71.
31	0.00	0.00	42.
32	0.00	0.00	27.
33	0.00	0.00	17.
34	0.00	0.00	10.
35	0.00	0.00	6.
36	0.00	0.00	3.
37	0.00	0.00	2.
38	0.00	0.00	1.
39	0.00	0.00	0.
40	0.00	0.00	0.
41	0.00	0.00	0.
42	0.00	0.00	0.
43	0.00	0.00	0.
44	0.00	0.00	0.
45	0.00	0.00	0.
46	0.00	0.00	0.
47	0.00	0.00	0.
48	0.00	0.00	0.
49	0.00	0.00	0.
50	0.00	0.00	0.
51	0.00	0.00	0.
52	0.00	0.00	0.
53	0.00	0.00	0.
54	0.00	0.00	0.
55	0.00	0.00	0.
56	0.00	0.00	0.
57	0.00	0.00	0.
58	0.00	0.00	0.

59	0.00	0.00	0.00	0.00
60	0.00	0.00	0.00	0.00
61	0.00	0.00	0.00	0.00
62	0.00	0.00	0.00	0.00
63	0.00	0.00	0.00	0.00
64	0.00	0.00	0.00	0.00
65	0.00	0.00	0.00	0.00
66	0.00	0.00	0.00	0.00
67	0.00	0.00	0.00	0.00
68	0.00	0.00	0.00	0.00
69	0.00	0.00	0.00	0.00
70	0.00	0.00	0.00	0.00
71	0.00	0.00	0.00	0.00
72	0.00	0.00	0.00	0.00
73	0.00	0.00	0.00	0.00
74	0.00	0.00	0.00	0.00
75	0.00	0.00	0.00	0.00
76	0.00	0.00	0.00	0.00
77	0.00	0.00	0.00	0.00
78	0.00	0.00	0.00	0.00
79	0.00	0.00	0.00	0.00
80	0.00	0.00	0.00	0.00
81	0.00	0.00	0.00	0.00
82	0.00	0.00	0.00	0.00
83	0.00	0.00	0.00	0.00
84	0.00	0.00	0.00	0.00
85	0.00	0.00	0.00	0.00
86	0.00	0.00	0.00	0.00
87	0.00	0.00	0.00	0.00
88	0.00	0.00	0.00	0.00
89	0.00	0.00	0.00	0.00
90	0.00	0.00	0.00	0.00
91	0.00	0.00	0.00	0.00
92	0.00	0.00	0.00	0.00
93	0.00	0.00	0.00	0.00
94	0.00	0.00	0.00	0.00
95	0.00	0.00	0.00	0.00
96	0.00	0.00	0.00	0.00
97	0.00	0.00	0.00	0.00
98	0.00	0.00	0.00	0.00
99	0.00	0.00	0.00	0.00
100	0.00	0.00	0.00	0.00

SUM 5.20 4.25 33293.

PEAK	6-HOUR	24-HOUR	72-HOUR	TOTAL VOLUME
47.50	1385.	347.	333.	33295.
CFS	4.30	4.30	4.30	4.30
INCHES	687.	688.	688.	688.
AC-FT				

HYDROGRAPH ROUTING

ROUTING THROUGH RESERVOIR
 ISTAG ICONIF 1 1

IECON ITAPE JPLT JPRT INAME
 0 0 0 0 1

ROUTING DATA
 GLOSS CLOSS AVG IRES ISAME
 0.0 0.000 0.00 1 0

NSTPS NSTOL LAG AMSKK X TSK STORA
 : 0 0 0.000 0.000 0.000 0.000 0.

STORAGE= 0. 10. 12. 38. 55. 71. 75. 122. 149.
 OUTFLOW= 0. 125. 350. 645. 990. 1300. 1465. 5900. 9130.

TIME	EOP	STOR	AVG IN	EDP	OUT
1	0.	0.	0.	0.	0.
2	0.	0.	0.	0.	0.
3	0.	0.	0.	0.	0.
4	0.	0.	0.	0.	0.
5	0.	0.	0.	0.	0.
6	0.	0.	0.	0.	0.
7	0.	0.	0.	0.	0.
8	0.	0.	4.	1.	1.
9	1.	34.	34.	8.	8.
10	3.	125.	125.	35.	35.
11	8.	304.	304.	97.	97.
12	16.	580.	580.	234.	234.
13	28.	927.	927.	455.	455.
14	43.	1319.	1319.	749.	749.
15	64.	1943.	1943.	1157.	1157.
16	88.	3047.	3047.	2558.	2558.
17	105.	4247.	4247.	4216.	4216.
18	111.	4691.	4691.	4700.	4700.
19	105.	4154.	4154.	4132.	4132.
20	96.	3205.	3205.	3181.	3181.
21	86.	2347.	2347.	2419.	2419.
22	77.	1733.	1733.	1792.	1792.
23	73.	1282.	1282.	1373.	1373.
24	66.	956.	956.	1198.	1198.
25	58.	729.	729.	1042.	1042.
26	49.	555.	555.	875.	875.
27	41.	407.	407.	713.	713.
28	34.	282.	282.	566.	566.
29	27.	183.	183.	436.	436.
30	22.	106.	106.	327.	327.
31	17.	57.	57.	245.	245.
32	13.	35.	35.	181.	181.
33	10.	22.	22.	133.	133.
34	8.	14.	14.	104.	104.
35	7.	8.	8.	82.	82.
36	5.	5.	5.	64.	64.
37	4.	4.	4.	50.	50.
38	3.	3.	3.	39.	39.
39	2.	2.	2.	30.	30.
40	2.	2.	2.	23.	23.

96	0.	0.	0.	0.
97	0.	0.	0.	0.
98	0.	0.	0.	0.
99	0.	0.	0.	0.
100	0.	0.	0.	0.

SUM 33295.

PEAK	6-HOUR	24-HOUR	72-HOUR	TOTAL VOLUME
4700.	1370.	347.	333.	33295.
CFS	4.25	4.30	4.30	4.30
INCHES	680.	688.	688.	688.
AC-FT				

RUNOFF SUMMARY, AVERAGE FLOW

HYDROGRAPH AT	PEAK	6-HOUR	24-HOUR	72-HOUR	AREA
ROUTED TO	4760.	1385.	347.	333.	3.00
	4700.	1570.	347.	333.	3.00