

LEVEL 1

12
B.S.



ADA 087799

**DEPARTMENT OF DEFENCE
DEFENCE SCIENCE AND TECHNOLOGY ORGANISATION
AERONAUTICAL RESEARCH LABORATORIES ✓**

AERODYNAMICS NOTE 391 ✓

**WESSEX MODERNIZATION:
A PRELIMINARY SIMULATION STUDY**

by

C. R. GUY

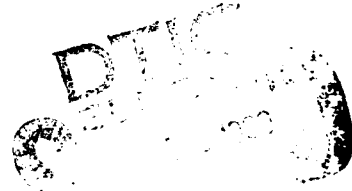

Approved for Public Release.



© COMMONWEALTH OF AUSTRALIA 1979

APRIL 1979

DDC FILE COPY

No 14

80 8 12 010

DEPARTMENT OF DEFENCE
DEFENCE SCIENCE AND TECHNOLOGY ORGANISATION
AERONAUTICAL RESEARCH LABORATORIES

12

AERODYNAMICS NOTE 391

11) 4/2/41

①
WESSEX MODERNIZATION:
A PRELIMINARY SIMULATION STUDY,

(A) 7/3/41

by
D. R. GUY
Christopher

DTIC
AUG 13 1980

14 AF/A. - 0 NIT: - 112

SUMMARY

A preliminary simulation study for a modernized Wessex helicopter, proposed for use by the RAN, is presented. The study uses mathematical models of the Wessex Mk31B aerodynamics/kinematics and modified Sea King Mk50 flight control system to simulate the flight dynamic behaviour of the modernized Wessex. Results indicate that good flight performance can be obtained provided system parameters are chosen correctly.

POSTAL ADDRESS: Chief Superintendent, Aeronautical Research Laboratories,
Box 4331, P. O., Melbourne, Victoria, 3001, Australia

This document has been approved
for public release and sale; its
distribution is unlimited.

11/2/80

DOCUMENT CONTROL DATA SHEET

Security classification of this page: Unclassified

- | | |
|----------------------------------------------------------------------------------------------------------------------------------------------------------------------------------|------------------------------------------------------------------------------------------------------------------------------------------------------------------------------------|
| <p>1. Document Numbers</p> <p>(a) AR Number:
AR-001-727</p> <p>(b) Document Series and Number:
Aerodynamics Note 391</p> <p>(c) Report Number:
ARL-Aero-Note-391</p> | <p>2. Security Classification</p> <p>(a) Complete document:
Unclassified</p> <p>(b) Title in isolation:
Unclassified</p> <p>(c) Summary in isolation:
Unclassified</p> |
|----------------------------------------------------------------------------------------------------------------------------------------------------------------------------------|------------------------------------------------------------------------------------------------------------------------------------------------------------------------------------|

3. Title: WESSEX MODERNIZATION: A PRELIMINARY SIMULATION STUDY

- | | |
|-------------------------------------------------------|------------------------------------------|
| <p>4. Personal Author(s):
Guy, Christopher R.</p> | <p>5. Document Date:
April, 1979</p> |
| <p>6. Type of Report and Period Covered:</p> | |

- | | |
|-----------------------------------------------------------------------|----------------------------------------------------------------------------|
| <p>7. Corporate Author(s):
Aeronautical Research Laboratories</p> | <p>8. Reference Numbers</p> <p>(a) Task:</p> <p>(b) Sponsoring Agency:</p> |
| <p>9. Cost Code:
51 2130</p> | |

- | | |
|---------------------------------------------------------------------------|----------------------------------------------------------------------------------------------------------|
| <p>10. Imprint:
Aeronautical Research Laboratories,
Melbourne</p> | <p>11. Computer Program(s)
(Title(s) and language(s)):
RW (CSMP-10 (ARL) and
Fortran IV)</p> |
|---------------------------------------------------------------------------|----------------------------------------------------------------------------------------------------------|

12. Release Limitations (of the document)
Approved for public release

12-0. Overseas:	N.O.	P.R.	I	A	B	C	D	E
-----------------	------	------	---	---	---	---	---	---

13. Announcement Limitations (of the information on this page):
No limitations

- | | | |
|-----------------------------------------------------------------------------|------------------------------------------------|--------------------------------------------------|
| <p>14. Descriptors:</p> <p>Control equipment</p> <p>Mathematical models</p> | <p>Flight control</p> <p>Wessex helicopter</p> | <p>15. Cosati Codes:</p> <p>0103</p> <p>1201</p> |
|-----------------------------------------------------------------------------|------------------------------------------------|--------------------------------------------------|

16. **ABSTRACT**

A preliminary simulation study for a modernized Wessex helicopter, proposed for use by the RAN, is presented. The study uses mathematical models of the Wessex Mk31B aerodynamics kinematics and modified Sea King Mk50 flight control system to simulate the flight dynamic behaviour of the modernized Wessex. Results indicate that good flight performance can be obtained provided system parameters are chosen correctly.

CONTENTS

1. INTRODUCTION	1
2. THE AERODYNAMICS/KINEMATICS MODEL	2
2.1 Assumptions and Comments	2
2.1.1 Rotor-induced velocity	2
2.1.2 Rotor-blade characteristics	2
2.1.3 Rotor-blade motion	2
2.1.4 Other	2
2.2 Structure of the Model	2
2.2.1 Main rotor aerodynamics	2
2.2.2 Axis transformation	3
2.2.3 Tail rotor aerodynamics	3
2.2.4 Fuselage aerodynamics	3
2.2.5 Equations of motion of the helicopter	3
2.2.6 Kinematics	3
3. THE FLIGHT CONTROL SYSTEM MODEL	3
3.1 Flying Controls	3
3.1.1 Pitch channel	3
3.1.2 Roll channel	3
3.1.3 Yaw channel	4
3.1.4 Collective channel	4
3.2 Automatic Flight Control System	4
3.2.1 Autostabilizer/autopilot and barometric height hold modes	4
3.2.2 Doppler and radio altitude hold modes	5
4. SAMPLE RESULTS	6
5. CONCLUDING REMARKS	7
NOMENCLATURE	
REFERENCES	
APPENDIX I. Fundamental Control Laws	
FIGURES	
DISTRIBUTION	

Accession For	
NTIC Control	<input checked="" type="checkbox"/>
DDC TAB	<input type="checkbox"/>
Unpublished	<input type="checkbox"/>
Justification	
A	

1. INTRODUCTION

This study results from the planned replacement of the Royal Australian Navy (RAN) Wessex Mk31B and Iroquois utility helicopters by either a new helicopter type or a modernized Wessex. In respect of the latter option, Hawker de Havilland Australia Pty. Ltd., are undertaking a design definition study covering the costing and technical implications of the modernization.

The aspect of the proposed modernization studied here is the fitting of a Louis Newmark flight control system (FCS), based on the Sea King system, into the Wessex. As this type of FCS has not been used in a Wessex hitherto, this study is useful in evaluating the feasibility of the exercise and in calculating the values of parameters (gains, time constants etc.) to be used in the control systems. The study also illustrates the standard of performance which may be expected from the aircraft/flight control system and should be useful in aiding flight testing of the prototypes.

The study is carried out using mathematical models and their associated computer programs for the Wessex Mk31B aerodynamics/kinematics and the Sea King Mk50 flight control system. These models may be joined together to represent a model of the modernized Wessex so that its dynamic flight behaviour can be studied under a wide range of conditions. The effects of varying control system parameters on flight behaviour may be investigated easily.

In undertaking a study of this type, certain simplifying assumptions are necessary. The aerodynamics/kinematics part of the model is taken from Packer's work (Ref. 1) and consequently is directed towards the behaviour of the aircraft at low speeds such as occur in automatic transitions from cruising flight to near-hover conditions. In addition, the rotor aerodynamics is based on blade element and actuator-disc theory rather than detailed wake modelling techniques to produce a realistic, manoeuvrable and versatile model without undue complexity.

The control systems model used in the study represents the overall control laws and systems used in the aircraft, although it does not represent each individual element of the aircraft's flying controls and automatic flight control system. The approach adopted in formulating this model was to keep the control systems simple, but without impairing their ability to work realistically. To do this, characteristics such as the input/output relationships of the primary servos are represented as constant gearings, with time constants and non-linearities neglected, because they have little effect on the behaviour of the aircraft in the majority of operating conditions. However, facilities such as FCS authority limits, the automatic cyclic stick (beeper) trim system and the secondary servo open-loop spring operation, which have a significant influence on aircraft behaviour, are included.

An overall block diagram showing the relationships between the components of the modernized Wessex model is given in Figure 1. Block 1 is an empirical human pilot model which enables FCS mode decisions and stick/pedal movements to be executed. These movements are input to block 2, a model of the flying controls, and result in collective, cyclic and tail rotor blade angles. Blocks 3 and 4 collectively represent the aerodynamics/kinematics model. The blade angles supplied to block 3 act through the aerodynamics of the rotors and airframe to produce forces and moments, and the aircraft dynamics (block 4) transforms these into aircraft motions. Wind velocity relative to the ground is supplied by means of block 5. When the pilot selects the autostabilizer, autopilot mode of the AFCS, a feedback loop around the aerodynamics is formed through blocks 6, 7 and 2. Block 6 represents motion sensors such as gyros, barometric altimeter and compass, while block 7 represents the autostabilizer autopilot mode of the AFCS amplifier unit. When the doppler and/or radio altimeter modes are selected, a second feedback loop is formed around the aerodynamics which includes blocks 8 and 9. Block 8 represents the doppler radar and radio altimeter sensing devices, while block 9 represents the doppler and radio altimeter modes of the AFCS amplifier unit. It should be noted that only principal paths and

switchings have been included in Figure 1 and more detail of the model is included in the relevant sections of this document.

2. THE AERODYNAMICS/KINEMATICS MODEL

The theoretical derivation of the aerodynamics and kinematics mathematical model for the Wessex Mk31B helicopter is described in Reference 1 and the Aeronautical Research Laboratories (ARL) computer program for this is outlined in Reference 2. The model is applicable to most kinds of flight manoeuvres, although its accuracy of prediction of steady state behaviour can be expected to decrease at advance ratios greater than about 0.2. The main assumptions and features of the model (extracted from Ref. 1) are summarized in this section.

2.1 Assumptions and Comments

2.1.1 Rotor-induced velocity

It is assumed that the velocity of flow induced through the rotor is constant over the disc. In addition, the model predicts the variation of the mean induced velocity with blade angle input, aircraft motion and thrust over the full range of high lift and negative lift and through the vortex-ring state.

2.1.2 Rotor-blade characteristics

- (i) The rotor blades are assumed to be infinitely stiff in torsion and bending (a valid assumption for this model).
- (ii) Reversed flow on the retreating blades is ignored, but for simulation purposes, this effect should be negligible for speeds up to 83 kt (43 m/s).
- (iii) Blade stall and compressibility effects are ignored.
- (iv) Blade spanwise twist, flap-hinge radial offset, blade root radius and tip-loss are all taken into account.

2.1.3 Rotor-blade motion

- (i) Rotor blade motion components at the higher harmonics of the basic rotor frequency are neglected.
- (ii) Transient rotor-disc motions excited by fuselage motion disturbances are ignored.
- (iii) Rotor speed is assumed to be held constant even in high torque situations.

2.1.4 Other

- (i) The model includes all inter-plane cross-coupling terms whether inertial or aerodynamic and so is not limited to small perturbation studies. The model is not simply an empirical one in which "derivatives" are fitted to experimental data.
- (ii) Generally, terms higher than first order in advance ratio and blade root ratios, have been omitted.

2.2 Structure of the model

Figure 2 presents a block diagram of the structure of the model (based on Ref. 1). This shows the model as a group of six blocks and the connections between these, representing information-flow, form a set of closed loops. Brief descriptions of these blocks follow:

2.2.1 Main rotor aerodynamics

In this section the main rotor inflow, forces and moments are derived, on the basis of the assumptions of Section 2.1. Aircraft motion components and rotor blade angle changes are first expressed in the helicopter shaft-axis system, then resolved into axes-of-no-feathering (ANF axes), so that rotor forces, moments, induced flow and flapping coefficients can be evaluated. The ANF axes move angularly so as to contain the apparent wind vector and are referred to as W (wind shaft) axes in Figure 2.

2.2.2 Axes transformation

The aerodynamics forces and moments acting on the main rotor, which have been resolved in ANF axes, are transformed into helicopter axes (H-axes on Fig. 2), which are fixed in the vehicle.

2.2.3 Tail-rotor aerodynamics

The analysis of the aerodynamics of the tail-rotor is very similar in form to that of the main rotor. The concepts of ANF axes aligned into the apparent wind direction and wind/shaft axes are again employed. There is, of course, no need for cyclic pitch control of the tail rotor.

2.2.4 Fuselage aerodynamics

The aerodynamics loads on the fuselage and tail assembly of a helicopter are generally small compared with the major airloads on the rotors. This is especially true in the low-to-medium speed flight range for which this model is predominantly designed. Consequently, only rough approximations to these loads have been included.

2.2.5 Equations of motion of the helicopter

To complete the derivation of helicopter motion, all the forces are combined to give the total aerodynamic forces along the three helicopter axes. The moments are similarly combined to give the total aerodynamic moments about the three axes. The classical equations of motion of a rigid body, expressed in axes fixed in the body, are then applied to provide motion of the helicopter relative to axes fixed in the earth, and resolved into moving helicopter axes (H-axes).

2.2.6 Kinematics

Using the Euler angle method, transformations from helicopter axes to earth axes are made to give components of helicopter velocity relative to the earth, in earth axes. The position co-ordinates of the helicopter (in earth axes), can be derived from the velocities by integration. Other quantities used in the main rotor, tail rotor and fuselage aerodynamics are also calculated in this Section (see Fig. 2).

3. THE FLIGHT CONTROL SYSTEM MODEL

As part of the Wessex modernization task, Louis Newmark Ltd. have reported on a flight control system for the Wessex Mk.31B, based on the Sea King FCS (Ref. 3). This section describes a mathematical model of this FCS which is to be used in conjunction with the aerodynamics kinematics model outlined in Section 2. The FCS model is derived from the simplified control systems mathematical model for the Sea King Mk 50 reported in detail in Reference 4. A general description of the arrangement is given here together with block diagrams (Figs 3-15) and fundamental control laws are presented in Appendix 1.

3.1 Flying controls

3.1.1 Pitch channel (Fig. 3)

A block diagram for the simplified pitch channel flying controls is shown in Figure 3. The longitudinal cyclic blade pitch angle BIS^{\dagger} comprises the longitudinal cyclic stick angle (THE STK) multiplied by gearing (CP), plus the AFCS output signal (AUTO PL). An integrator is used to model the cyclic stick so that THE STK can be generated either by the pilot (THE PIL) or the beeper trim system (THE TDT).

3.1.2 Roll channel (Fig. 4)

Similar to pitch channel.

\dagger Throughout this document, the nomenclature for variables is of the type used here.

3.1.3 Yaw channel (Fig. 5)

Unlike the secondary servos in the pitch and roll channels, that in the yaw channel incorporates an open-loop spring which influences the operation of the flying controls and hence must be represented. Referring to Figure 5, the secondary servo has been mathematically modelled as a first order lag circuit, with an extra input for the AFCS signal (AUTO YL) and an open-loop spring linkage position (D SPR Y). D SPR Y operates through the spring compression limit EL OY and gearing CY11 to produce the rate of change of pedal movement (D PED DT) during open-loop spring operation. Constant CY2 represents the mid-point of the range of THETA T.

3.1.4 Collective channel (Fig. 6)

Assuming that an open-loop spring system is retained (rather than replaced by a parallel actuator), this is generally similar to the yaw channel.

3.2 Automatic Flight Control System

3.2.1 Autostabilizer/autopilot and barometric height hold modes

3.2.1.1 Pitch channel (Fig. 7)

The attitude holding and stabilizing characteristics of the system are achieved by use of the geared pitch attitude angle signal (THE HE * CP3) and its geared approximate derivative. The stick canceller signal (THE STK * CP2) partially cancels the attitude signal so as to allow a wider range of attitude control without exceeding the authority limit (EL AP) and also improves the response of the aircraft to pilot demands. Doppler mode and pitch trim signals are incorporated through the terms ASW P and THE TRM respectively.

3.2.1.2 Roll channel (Fig. 8)

This is similar to the pitch channel except for:

- (i) A lag network, which is used to improve the roll response of the aircraft. This operates on the combined stick canceller and trim signals.
- (ii) Sign conventions of terms (model only).

3.2.1.3 Yaw channel (Fig. 9)

When the stabilizer switch S AUTO Y is on and the pedals switch S PEDLS is off, heading hold and rate damping are provided. When both S AUTO Y and S PEDLS are on (pilot operating the pedals), the channel functions as a yaw damper only. Damping is provided by the geared R HEH rate feedback signal and heading hold is achieved through the heading error signal (PSI ERR) plus its integral (PSI INT). A washout loop is placed around the integrator to zero PSI INT after a new heading is adopted and limits are placed on the integrator (EL IY). A heading trim control (PSI TRM), a collective to yaw crossfeed signal (taken from THEC ST) and authority limits (EL AY) are all provided.

3.2.1.4 Barometric height hold (Fig. 10)

At the moment when the barometric height hold switch is engaged, the height datum (H REF) is set and subsequent deviations in height are fed through the collective channel to stabilize the aircraft at H REF. When a barometric altitude manoeuvre is made, S BAR A must be switched off. Immediately S BAR A is re-engaged, altitude hold is re-established relative to the new value of barometric altitude.

These facilities are achieved as follows. A reference altitude signal (H REF) is obtained from aircraft altitude (Z HEE) by means of a sample and hold device (note Z HEE and H REF are of opposite signs). The altitude error signal (BAR A) is the difference between Z HEE and H REF after smoothing by a gust filter. When open-loop spring operation of the secondary servo occurs, the collective stick position is determined by the feedback signal CLU A provided by a clutched stick position pick-off. EL AC represents the authority limit and RAD A the input from the radio altitude hold mode.

3.2.2 Doppler and radio altitude hold modes

Doppler and radio altitude hold facilities incorporated in the model are:

- (i) Radio altitude hold.
- (ii) Transition down.
- (iii) Doppler hover.
- (iv) Auxiliary hover trim.
- (v) Transition up.

Descriptions of these manoeuvres are given in References 3 and 4.

3.2.2.1 Pitch channel (Fig. 11)

This channel governs control of transition, doppler hover and auxiliary hover trim facilities in the fore-aft direction. The action of the control causes cyclic changes of blade pitch which result in airspeed variations and hence groundspeed changes.

To achieve control, a law which is essentially proportional plus integral is used. The longitudinal groundspeed error signal (ASW P) comprises:

- (i) The difference between the aircraft's longitudinal groundspeed (U HEH) and the reference longitudinal groundspeed (U COMM). U COMM determines the groundspeed profile for transition manoeuvres and is programmed to vary linearly from the entry speed to zero, or from zero to the exit speed, over a time period of 78s. Note that U HEH, which is used here in the model, is an approximation to the velocity signal provided by the ground velocity smoother in the control system of the aircraft.
- (ii) Signal CADO IP, which is the integral of the modified groundspeed error signal U ERR. U ERR is the difference between U HEH and U COMM when the latter has been fed through the 'aircraft model' lag circuit.
- (iii) The pitch auxiliary hover trim signal, P HOV T, which replaces the U COMM signal when the auxiliary hover trim facility is used (switch S AHT is on).

3.2.2.2 Roll channel (Fig. 12)

This is similar to the pitch channel except that a speed control program is not incorporated.

3.2.2.3 Radio altitude hold (Fig. 13)

For level flight with the radio altitude mode operative, H COMM is the set radio height and control maintains the height of the aircraft (Z HEE) at H COMM (note that the sign conventions for Z HEE and H COMM are opposite). During transition manoeuvres, H COMM varies linearly from the aircraft's altitude to the hover height (or vice-versa) over a time period of 62s. When large changes in height are demanded by the AFCS, open-loop operation of the secondary servo has the effect of trimming the collective lever (see also Section 3.2.1.4).

A law which is essentially proportional plus integral plus velocity damping is used for control. The radio altitude hold signal, RAD A, comprises:

- (i) An altitude error term (proportional to the difference between Z HEE and H COMM).
- (ii) A damping term (proportional to vertical velocity, W HEE).
- (iii) A signal proportional to the integral of the difference between Z HEE and H COMM when the latter is modified by an 'aircraft model' lag circuit.

3.2.2.4 Beeper trim system (Figs 14 and 15)

The beeper trim system provides for cyclic stick positioning, where control is accomplished automatically under signals from the AFCS, or by manual control switches on the cyclic stick. The system enables manual fine control of the cyclic stick and also extension of authority for the Doppler mode command signals by actuating the stick directly at a fixed rate. Block diagrams for the pitch and roll channels respectively are shown in Figures 14 and 15, and their operation is fully described in Reference 4.

4. SAMPLE RESULTS

To demonstrate the performance of the modernized Wessex, the results from three different tests are presented. In the first test, the Modernized Wessex, Wessex Mk31B and Sea King models were subjected to the following manoeuvre for comparison purposes:

- (i) Initial conditions; near-steady flight at a forward velocity of 68 ft/s† (40 kt or 20.7 m/s), altitude 120 ft (36.5 m), with autostabilizer, heading hold and radio altitude hold engaged.
- (ii) Transition to hover at 35 ft (10.7 m) altitude begun at 5s.
- (iii) Wind gust rising from zero to 35 ft/s (10.7 m/s) in 1s beginning at 95s, duration 5s.
- (iv) Run terminated at 120s.

Such a manoeuvre illustrates the performance of all parts of the control system except the barometric altitude hold and auxiliary hover trim facilities. The time histories of some important variables are shown in Figures 16, 17 and 18 for the modernized Wessex, Mk31B and Sea King respectively.

The second test was designed to show the performance of the barometric altitude hold facility in the modernized Wessex. To do this, a steady, level flight manoeuvre at a speed of 40 kt (20.7 m/s) was performed with the barometric altitude hold engaged. The aircraft was subjected to a downwards wind gust rising from zero to 5 ft/s (1.5 m/s) in 1s, beginning at 10s, duration 5s. Time histories for some relevant variables are shown in Figure 19.

The third test illustrates the operation of the auxiliary hover trim facility. The aircraft model was run from near hover initial conditions with the auxiliary hover trim and radio altitude hold facilities operating. After 5s of hovering, a step forward velocity command of 10 ft/s (3 m/s), lasting 15s and decaying over 10s in a ramp manner, was used to test the pitch channel auxiliary hover trim facility. A generally similar profile, starting after 35s, but having different dimensions, was also used to test the roll channel. Time histories for some relevant variables are shown in Figure 20.

It should be noted that in all tests, the fundamental control laws stated in Appendix I were used for the Modernized Wessex, where gains and time constants are based on Sea King values. Note also that care should be taken with scales when comparing the results of Figures 16-18.

Comments on the results from the tests are listed below:

1. Test 1, Figures 16-18.

- (i) Overall, the Modified Wessex performs the level flight, transition down and doppler hover manoeuvres, shown in Figure 16, smoothly and correctly.
- (ii) The Mk31B (Fig. 17) does not have pre-programmed transition profiles in height and velocity. An approximation to the manual procedure is made in the Mk31B model, which results in a faster transition down than the programmed manoeuvres of the Sea King and Modernized Wessex.
- (iii) It is not known whether the limit cycle oscillations apparent in the Mk31B model results (Fig. 17) occur in the aircraft. This model is a copy of the Weapons Research Establishment model of that helicopter (Refs 1, 5, 6 and 7) which has been validated by WRE. However, the presence of these oscillations is open to question. They appear to arise because of certain non-linearities in the control systems which have been modelled in the Mk31B but not in the simplified control systems of the Modified Wessex and Sea King.
- (iv) Although not immediately obvious from Figures 16-18, tighter control of height and velocity occur in the Modified Wessex and Sea King than in the Mk31B. When detailed studies of the relevant variables are made, the Mk31B overshoots its hover height and velocity at the end of the transition down and is slow to return to the demanded levels. The Modified Wessex and Sea King perform these manoeuvres more accurately.
- (v) The disturbances in the roll angle and sideways velocity time histories of the Modified Wessex at approximately 30s and 55s (Fig. 16) are due to lateral cyclic stick beeping.
- (vi) The disturbances which appear on Figures 16-18 starting at 95s are due to the wind

† Because the computer programs for the models use imperial units, they are retained here.

gust. The Modified Wessex and Mk31B are relatively unaffected by this, although the Sea King shows significant deflections in a number of variables. However, as the Sea King model has not yet been validated, this behaviour still has to be confirmed.

(vii) Note that aircraft altitude (Z HEE) is measured positive downwards in the results presented. This follows from the (standard) conventions used for body axes in the aircraft.

2. Test 2, Figure 19.

- (i) Barometric height hold functions satisfactorily in the Modified Wessex model.
- (ii) While the wind gust disturbs the model, it regains its set height in a smooth and reasonable manner.
- (iii) Note that the model has a residual roll angle when flying at 40 kt (20.7 m/s), which causes yaw angle to be non-zero in steady flight at this speed.

3. Test 3, Figure 20.

- (i) The auxiliary hover trim facility functions satisfactorily in the model.
- (ii) The pitch channel shows a slightly overdamped response to a step change in input, whereas the response of the roll channel is slightly underdamped. These characteristics could be adjusted easily by varying the system gains.

5. CONCLUDING REMARKS

A mathematical model for a Modernized Wessex, which has been proposed for use by the RAN, is described. This comprises:

- (i) An aerodynamics/kinematics model for the Wessex Mk31B.
- (ii) A flying controls model for the Mk31B which has a modified secondary servo.
- (iii) A modified automatic flight control system model for the Sea King Mk50, where modifications include removal of the cable mode facilities, the inclusion of a collective-to-yaw crossfeed term and the modified secondary servo.

Sample results, illustrating the performance of the aircraft with its control system, have indicated that the Modified Wessex will perform well if gain and time constants based on Sea King values are used. However, no attempt has been made to optimize values in this preliminary study. Although space has limited the number of results presented, the model can be used to determine the flight behaviour of the aircraft for a wide variety of manoeuvres.

If required, a more comprehensive study could follow up this preliminary work. In addition to presenting further results, modifications could be made to the aerodynamics kinematics and control systems models to improve their range and detail. For example, a detailed model of the Sea King control systems will be available in the near future, which simulates each individual element of the system and this could be modified to replace the simplified model (which simulates overall systems and laws) used here.

To conclude, the study presented here has confirmed the statement made in Reference 3 concerning the performance of the Modified Wessex: i.e. "It is expected that the performance obtained in Pitch, Roll, Yaw and Bar. Alt. will be as good as, and probably better than, that obtained in the Wessex 31B and that in Rad. Alt. and Transition Height a definite improvement over present standards will occur."

NOMENCLATURE

ASW P, ASW R	Doppler mode output signals
AUTO C, ... P, ... R, ... Y	Autostabilizer autopilot mode output signals unlimited
AUTO CL, ... PL, ... RL, ... YL	Autostabilizer autopilot mode output signals limited
AIS, BIS	Cyclic blade pitch angles
BAR A, RAD A	Height hold signals (barometric and radio respectively)
CADO IP, CADO IR	Doppler mode integral error signals
CC1, ... CC14	Constants (collective channel)
CLU A	Clutched collective stick difference signal
CLU ERR	Clutched collective stick error signal
CPI, ... CP12	Constants (pitch channel)
CRI, ... CR17	Constants (roll channel)
CY1, ... CY13	Constants (yaw channel)
D AUX C, D AUX Y	Auxiliary servo output positions
D PED DT	Rate of change of rudder pedals position
D PEDLS	Rudder pedals position
D PIL Y	Pilot's rudder pedals position
D SPR C, D SPR Y	Open-loop spring linkage positions
EL AC, ... AP, ... AR, ... AY	Autostabilizer autopilot authority limits
EL BP, EL BR	Beeping limits
EL IY	Yaw integrator limit
EL CC, ... CP, ... CR, ... CY	Control stop angles
EL OC, EL OY	Open-loop spring compression limits
H COMM	Reference radio altitude (positive upwards)
H REF	Reference barometric height (positive upwards)
PHI HE, PSI HE, THE HE	Attitude angle of helicopter relative to earth in roll, yaw and pitch respectively
PHI PIL, THE PIL	Pilot's cyclic stick angles
PHI STK, THE STK	Cyclic stick angles
PHI TDT, THE TDT	Cyclic stick angle rates of change
PHI TRM, PSI TRM, THE TRM	Trim angle signals in roll, yaw and pitch respectively
P HOV T, R HOV T	Pitch and roll auxiliary hover trim velocity demand signals respectively
PSI ERR	Heading error signal (proportional)

PSI INT	Heading error signal (integral)
PSI PI	Heading error signal (proportional plus integral)
PSI REF	Reference heading signal
R HEH	Yaw rate of helicopter relative to earth
s	Laplace operator
S AFT, S AFT H, S AFT NU	Aft motion beeping switches
S AHT	Auxiliary hover trim switch
S AUTO C, . . . P, . . . R, . . . Y	Autostabilizer/autopilot mode selector switches
S BAR A, S RAD A	Height hold selector switches, barometric and radio respectively
S DOP	Doppler mode selector switch
SC ST	Collective stick friction switch
S FWD, S FWD H, S FWD NU	Forward motion beeping switches
S MULT P, S MULT R	Multivibrator signals
S NEG P, S NEG R	Aft motion beeping switches
S PEDLS	Yaw force link switch
S PORT, S PORT H, S PORT NU	Port motion beeping switches
S POS P, S POS R	Forward motion beeping switches
S STBD, S STBD H, S STBD NU	Starboard motion beeping switches
S TRM RL	Cyclic stick trim release switch
t	Time
T CS PL	Pilot's collective stick angle
TC1, TC2	Time constants
TH CS D	Rate of change of collective stick angle
THE CLU	Clutched collective stick angle
THEC ST	Collective stick angle
THETA C, THETA T	Collective blade pitch angles, main and tail rotors respectively
TMP, TMR	'On' period for multivibrator signals
TPI, . . . TP3	Time constants
TRI, . . . TR5	Time constants
TSMP, TSMR	Multivibrator signal frequencies
TYI	Time constant
U COMM	Reference longitudinal groundspeed
U ERR	Modified longitudinal groundspeed error signal
U HEH, V HEH	Longitudinal and lateral groundspeeds respectively
W WEE	Wind gust velocity (vertical)

W HEE, W HEH

Vertical velocity relative to earth in earth and helicopter axes respectively

Z ERI

Integral radio altitude error signal

Z ERR

Barometric height error signal

Z HEE

Altitude (positive downwards)

REFERENCES

1. Packer, T. J. Wessex helicopter/sonar dynamics study. The mathematical model of the helicopter aerodynamics and kinematics. WRE Technical Memorandum SAD 203, November 1969.
2. Williams, N. V.,
Guy, C. R.,
Williams, M. J. and
Gilbert, N. E. Wessex helicopter/sonar dynamics study.
ARL program description and operation.
ARL Aerodynamics Note 385, February 1979.
3. — A flight control system for the Wessex Mk.31B based on the Sea King F.C.S. Louis Newmark publication, LN. 35.
4. Guy, C. R. Sea King Mk.50 helicopter/sonar dynamics study. A simplified control systems mathematical model. ARL Aerodynamics Report 152, February 1979.
5. Packer, T. J. Wessex helicopter/sonar dynamics study. Initial report. WRE Technical Note SAD 216, January 1969.
6. Packer, T. J. Wessex helicopter/sonar dynamics study. The mathematical model of the sonar cable and transducer. WRE Report 951 (WR & D), May 1973.
7. Packer, T. J. and
Lane, R. C. Wessex helicopter/sonar dynamics study. The system simulation program. WRE Technical Note 937 (WR & D), May 1973.

APPENDIX I

Fundamental Control Laws

The fundamental control laws (i.e. those having a similar form to the control laws given in Reference 3, but some different signs because of the sign conventions of the mathematical model) used in the simulation studies of the Modernized Wessex are stated below. Gain and time constant values, which are based on the Sea King laws, use units and values consistent with those of Reference 3. Some fine tuning of these values may still be required for optimum performance. The fundamental laws, which cover only the main features of the control system, do not contain all the terms used in the mathematical model block diagrams (Figs 3-15). However, a more detailed listing of the equations of the control systems mathematical model for the Sea King Mk50 is given in Reference 4. While the Modernized Wessex control systems mathematical model is not absolutely identical to that of the Sea King, changes should be self-evident by studying the block diagrams.

1. Flying Controls

1.1 Pitch channel

$$BIS = 0.832 * THE STK$$

1.2 Roll channel

$$AIS = 0.628 * PHI STK$$

1.3 Yaw channel

$$THETA T = (1.608 * D PEDLS) + 0.0938$$

1.4 Collective channel

$$THETA C = (0.743 * THEC ST) + 0.267$$

2. AFCS Autostabilizer/autopilot and barometric height hold modes

2.1 Pitch channel

$$BIS = \left(0.5 * THE HE \right) + \left(\frac{0.68s}{1 + 0.07s} * THE HE \right) + \left(0.37 * THE STK \right)$$

2.2 Roll channel

$$AIS = - \left(0.2 * PHI HE \right) - \left(\frac{0.13s}{1 + 0.01s} * PHI HE \right) + \left(\frac{1.4 * (1 + 0.1s)}{1 + s} * PHI STK \right)$$

2.3 Yaw channel

$$THETA T = (0.16 * PSI HE) + (0.61 * R HEH) + (0.03 * \int (PSI HE) dt) \\ + \left(\frac{0.43s}{1 + 2.0s} * THEC ST \right)$$

† To speed computation, a value of 0.05 has been used here for the simulation results shown in Section 4. Performance does not appear to be affected significantly by this change.

2.4 Barometric height hold

$$\text{THETA C} = \left(\frac{0.028}{1 + 0.45s} * \text{Z ERR} \right) - \left(0.2769 * \text{CLU ERR} \right)$$

3. AFCS Doppler and Radio Altitude Hold Modes

3.1 Pitch channel

$$\text{BIS} = \left(0.34 * \left(\text{U HEH} - \text{U COMM} \right) \right) - \left(0.021 * \int \left(\text{U HEH} - \frac{\text{U COMM}}{1 + 2.1s} \right) dt \right)$$

3.2 Roll channel

$$\text{AIS} = (0.7 * \text{V HEH}) - (0.022 \int (\text{V HEH}) dt)$$

3.3 Radio altitude hold

$$\text{THETA C} = (0.37 * (\text{Z HEE} + \text{H COMM})) + (0.46 * \text{W HEE}) \\ + \left(0.062 * \int \left(\text{Z HEE} + \frac{\text{H COMM}}{1 + 4.6s} \right) dt \right)$$

4. AFCS Authority limits (from Ref. 3)

Cyclic pitch	: 10°, total blade angle (BIS)
Cyclic roll	: 10°, total blade angle (AIS)
Yaw	: 10°, total blade angle (THETA T) (open loop spring operates at : 5°)
Collective	: 10°, total blade angle (THETA C) (open loop spring operates at : 5°)

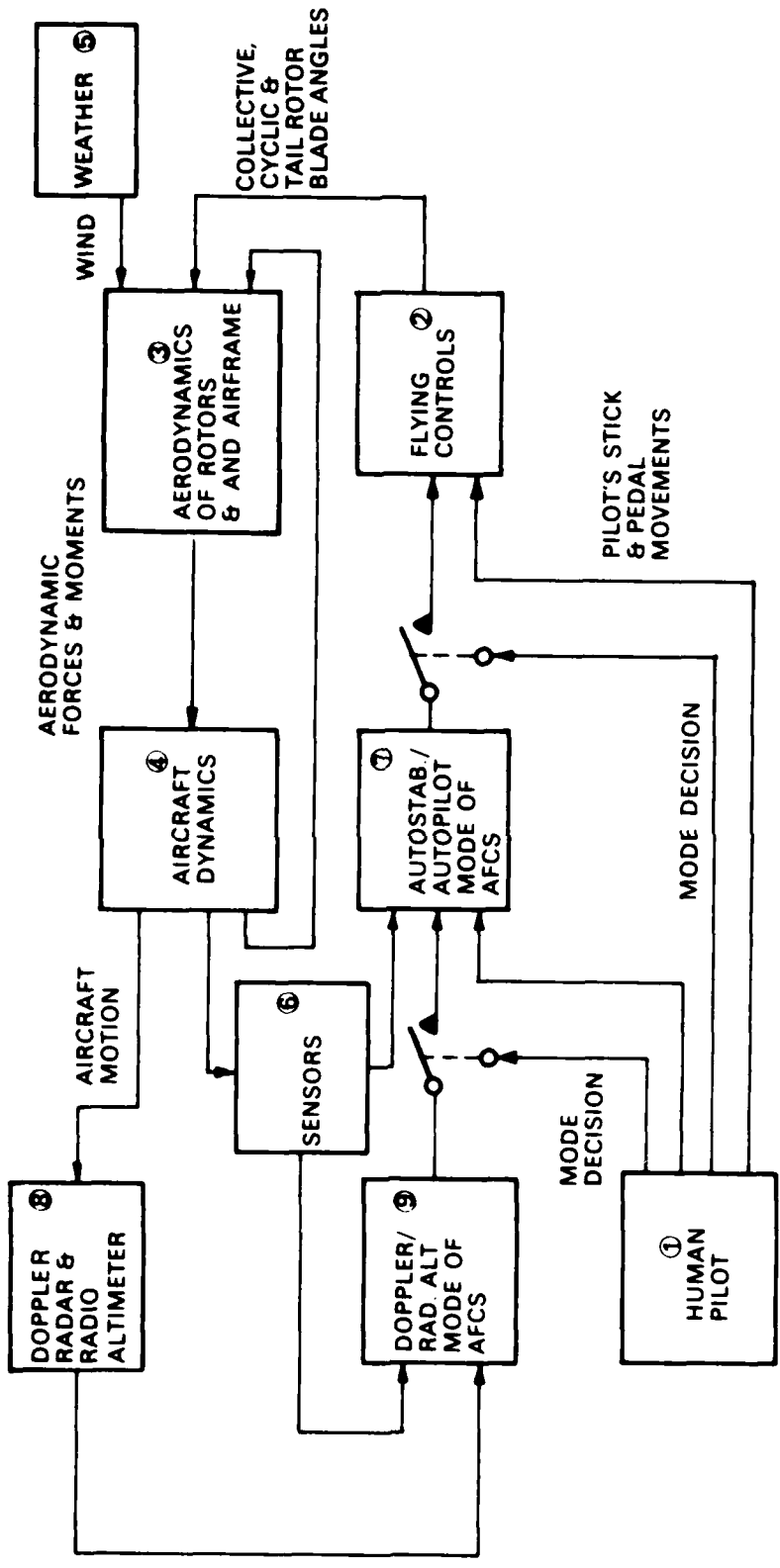

FIG 1 OVERALL BLOCK DIAGRAM FOR THE MODERNIZED WESSEX MODEL

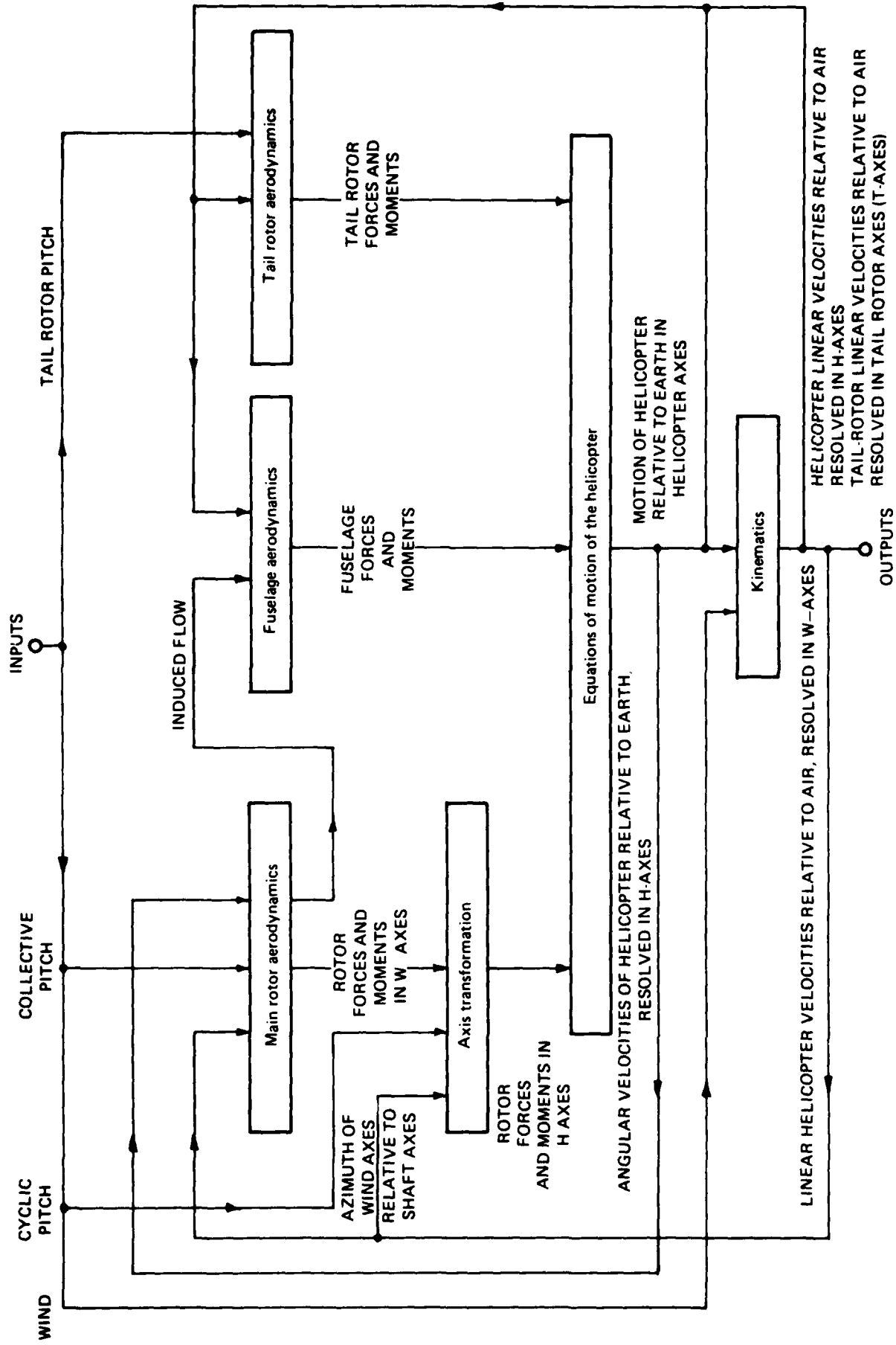

FIG 2. STRUCTURE OF THE AERODYNAMICS/KINEMATICS MODEL (based on ref 1)

Key to switch positions: ○--▽ 'ON'
○--▼ 'OFF'

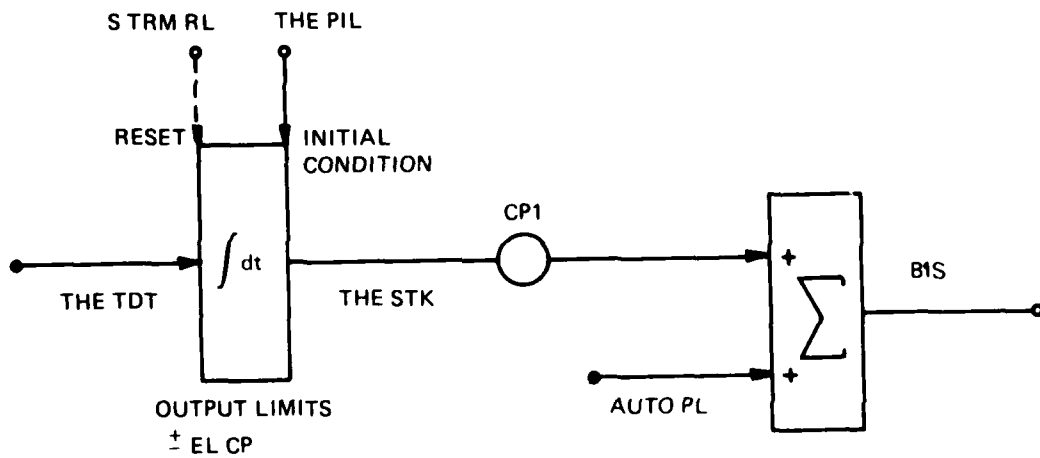

FIG 3. FLYING CONTROLS (PITCH CHANNEL)

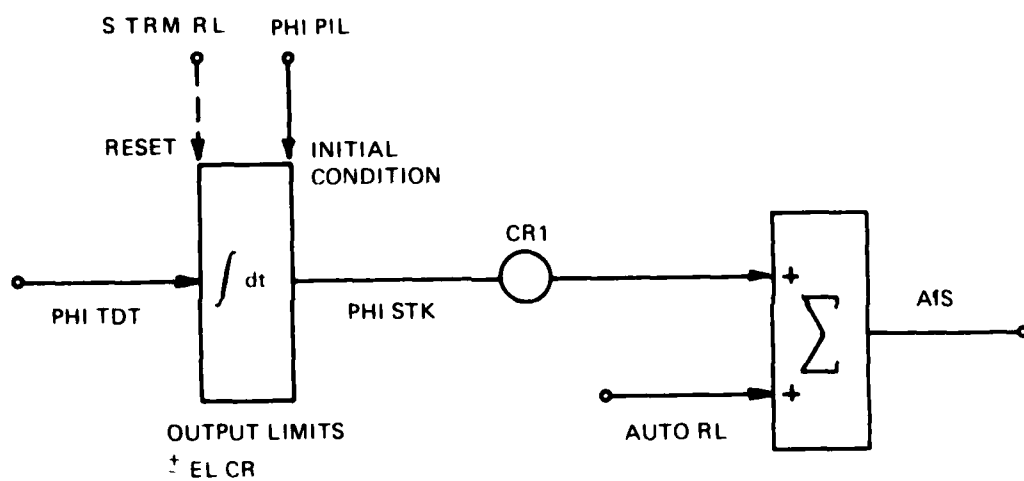

FIG 4. FLYING CONTROLS (ROLL CHANNEL)

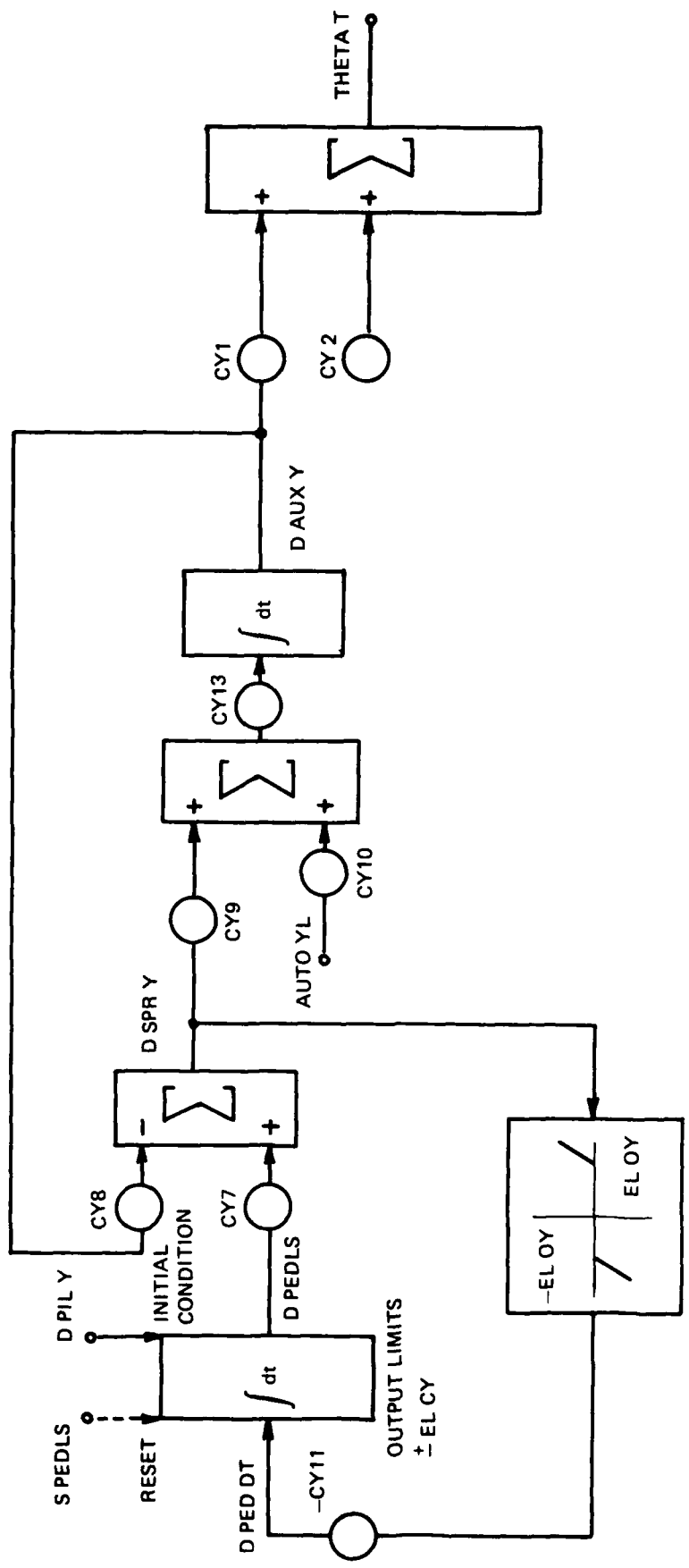

FIG 5. FLYING CONTROLS (YAW CHANNEL)

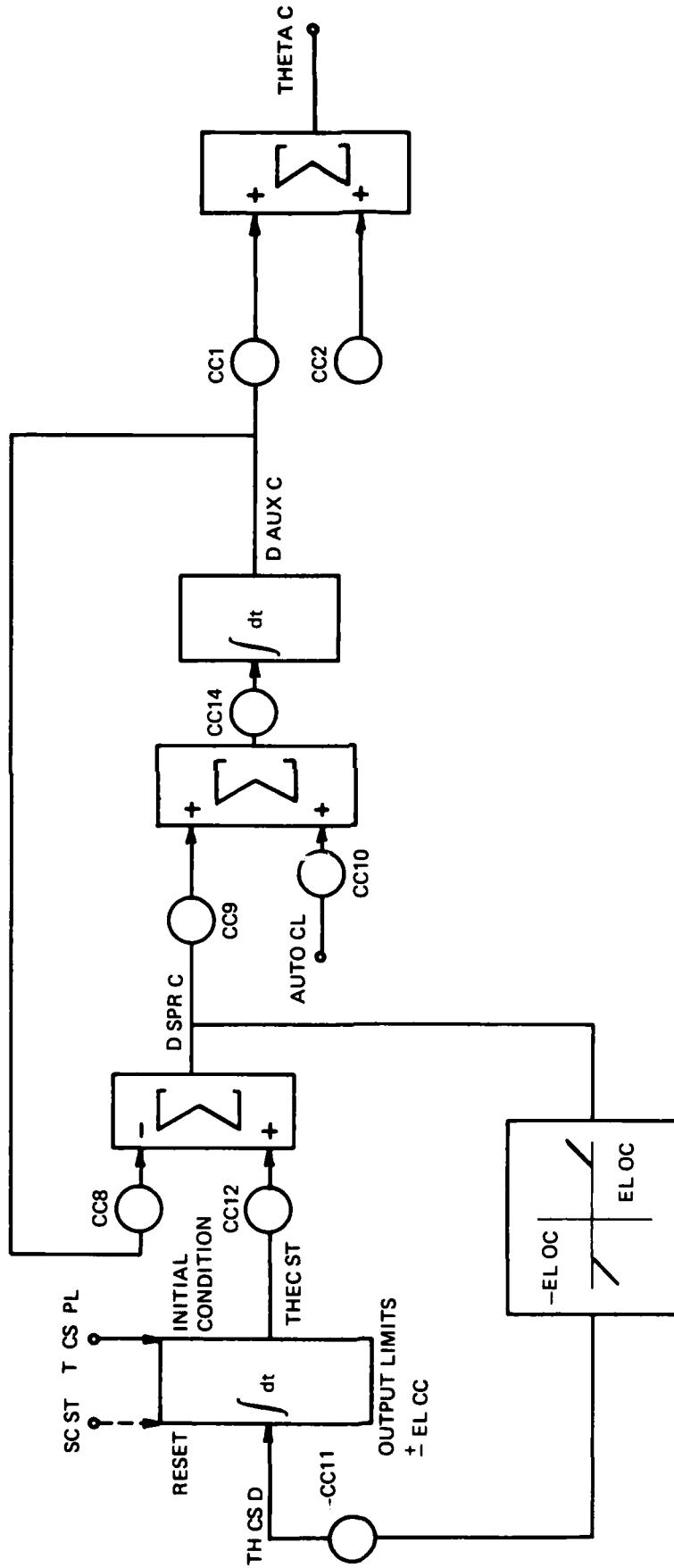

FIG 6. FLYING CONTROLS (COLLECTIVE CHANNEL)

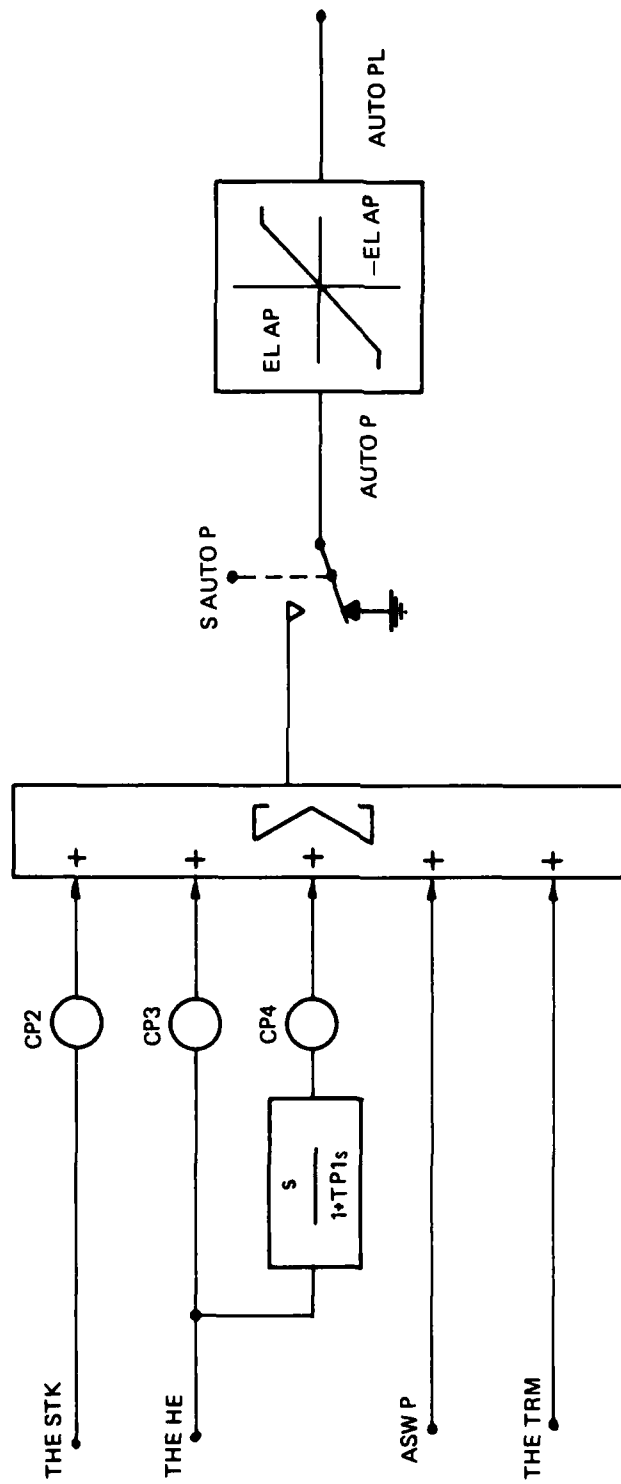

FIG 7. AFCS AUTOSTABILIZER/AUTOPILOT MODE (PITCH CHANNEL)

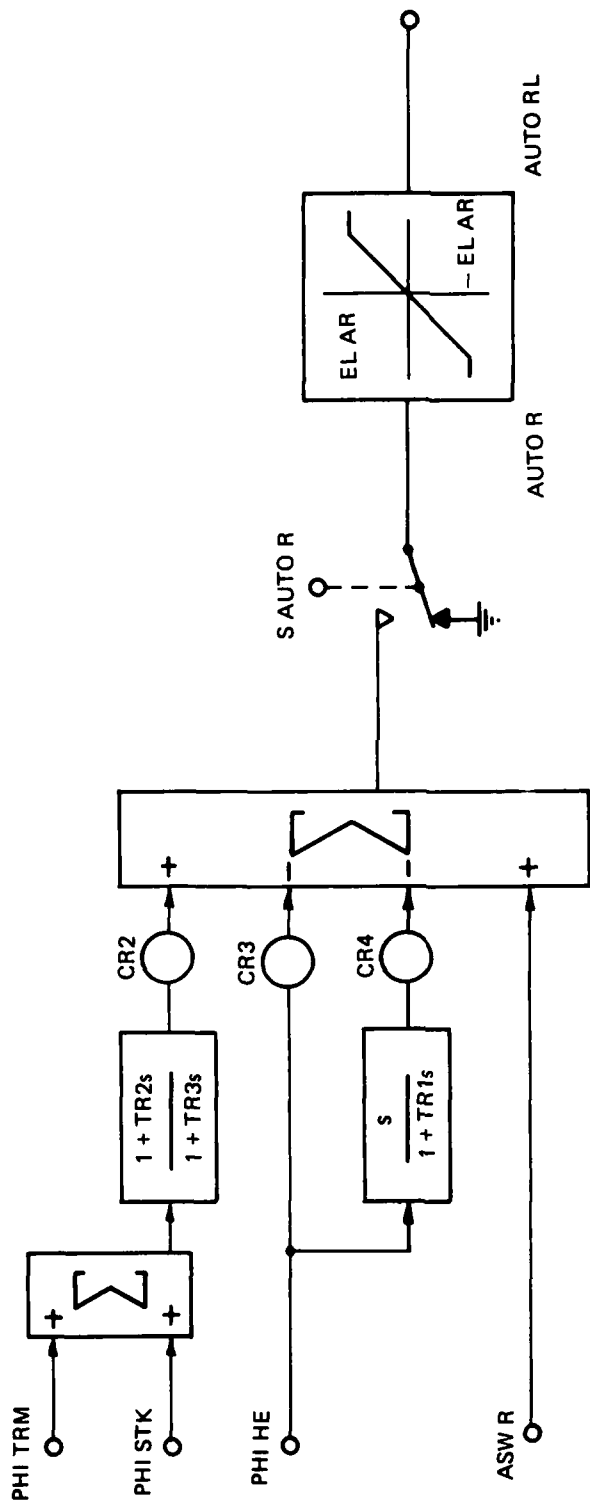

FIG 8. AFCS AUTOSTABILIZER/AUTOPILOT MODE (ROLL CHANNEL)

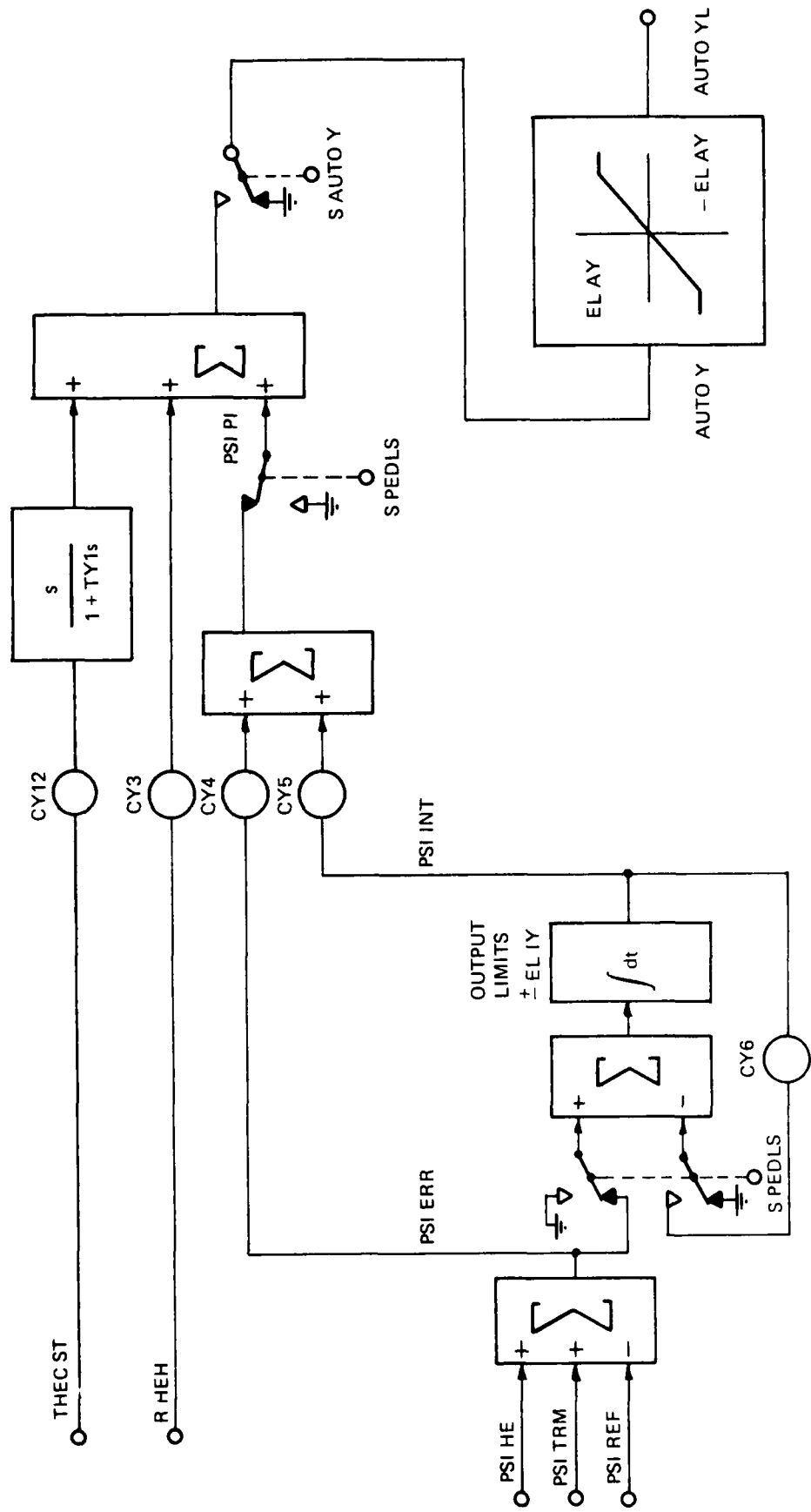

FIG. 9. A FCS AUTOSTABILIZER AUTOPILOT MODE (YAW STABILIZER AND HEADING HOLD)

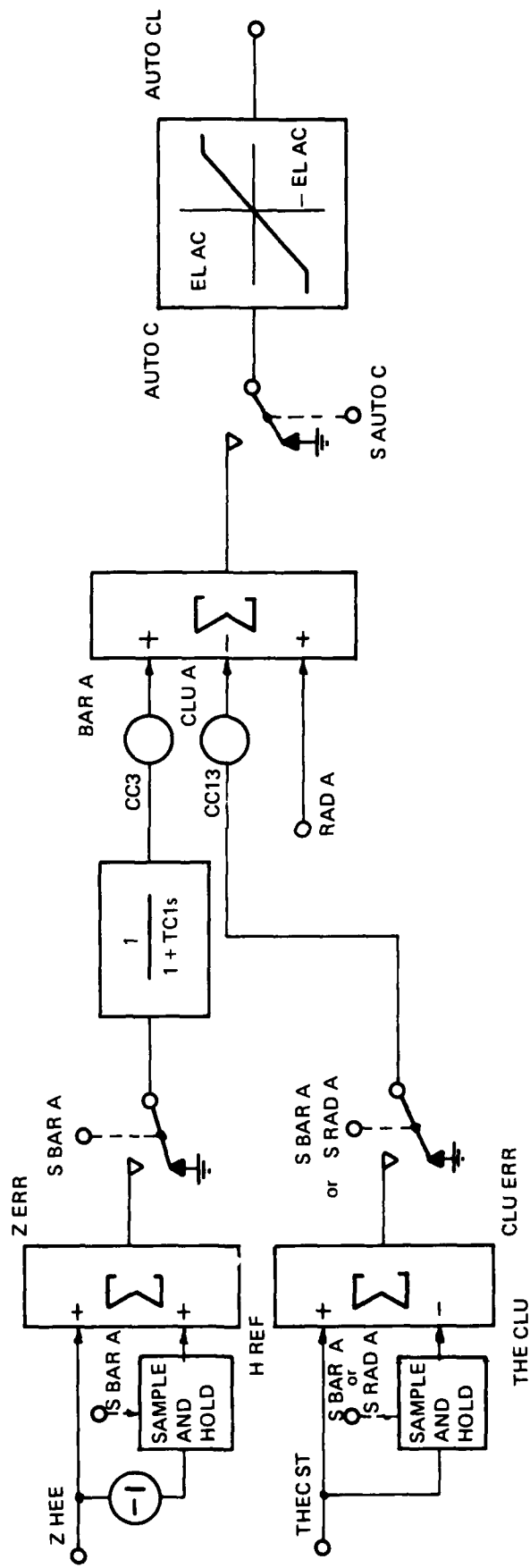

FIG 10. AFCS AUTOSTABILIZER/AUTOPILOT MODE (BAROMETRIC HEIGHT HOLD)

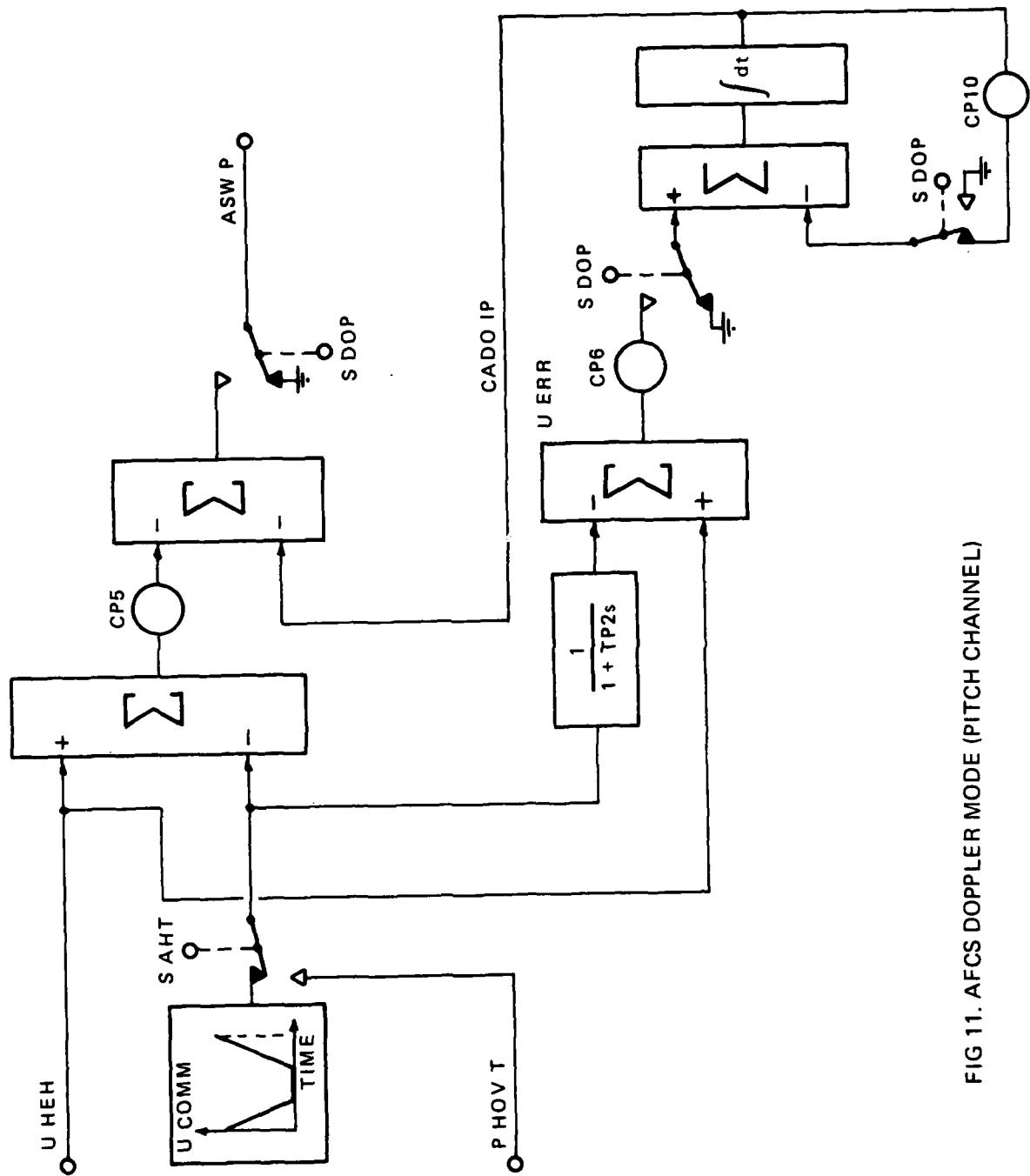

FIG 11. AFCS DOPPLER MODE (PITCH CHANNEL)

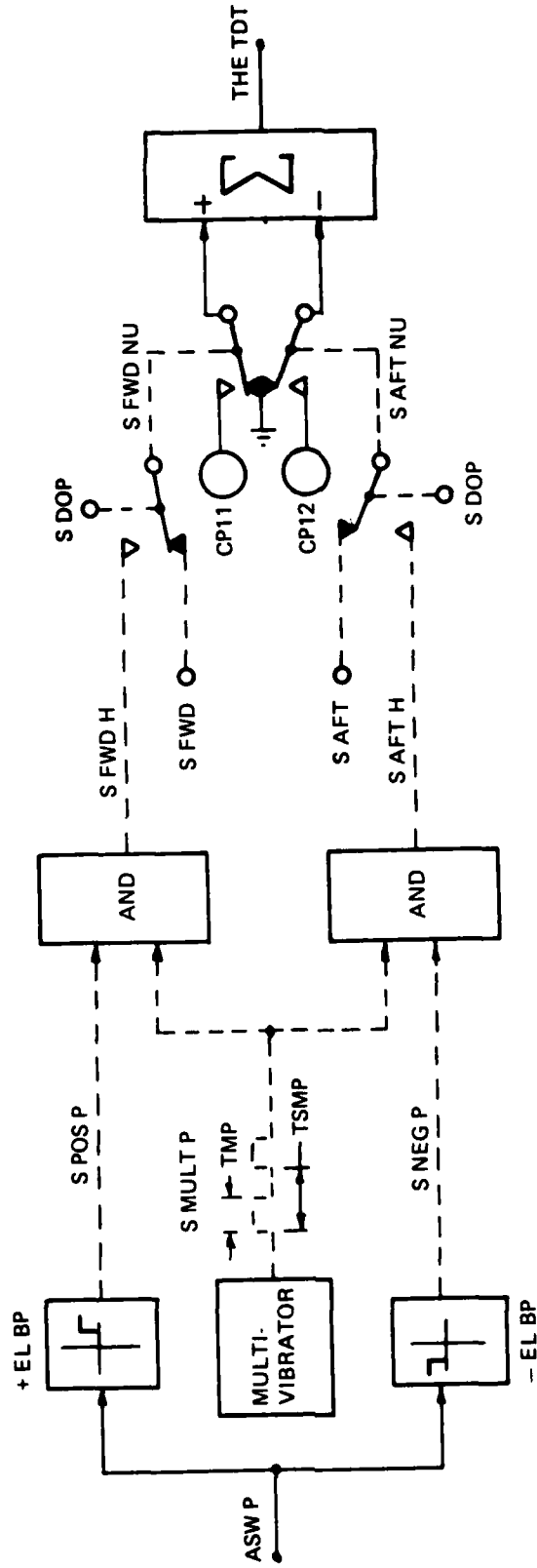

FIG 14. BEEPER TRIM SYSTEM (PITCH CHANNEL)

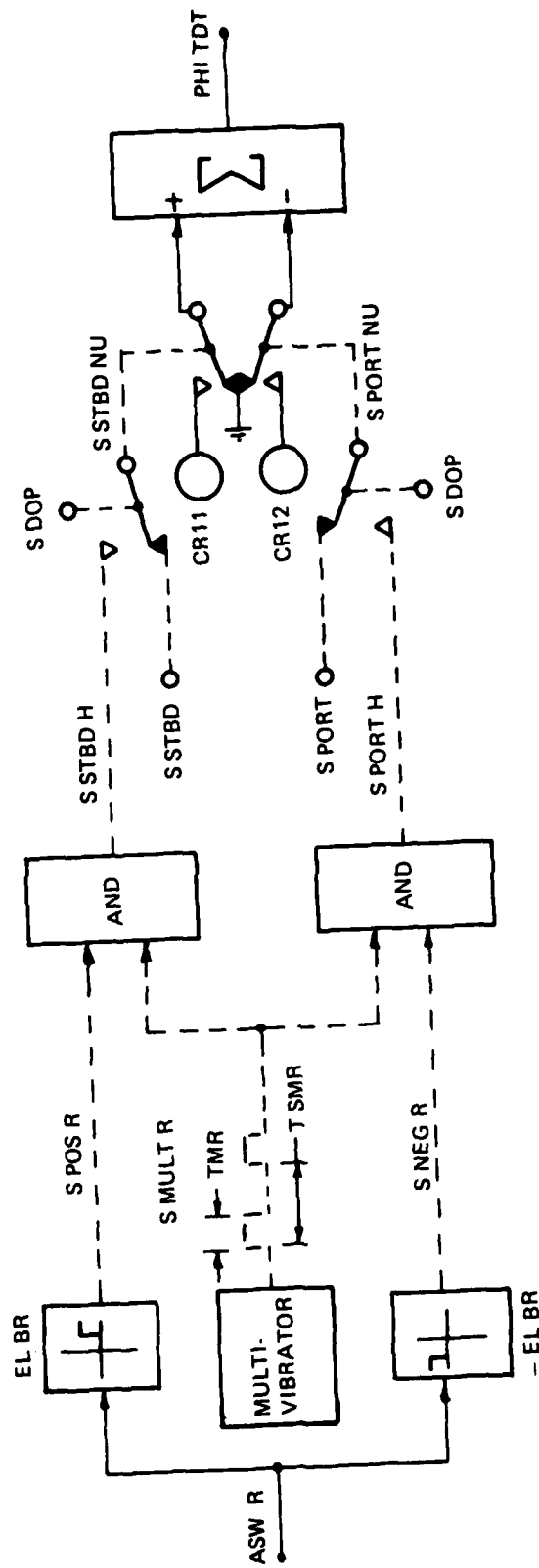

FIG 15. BEEPER TRIM SYSTEM (ROLL CHANNEL)

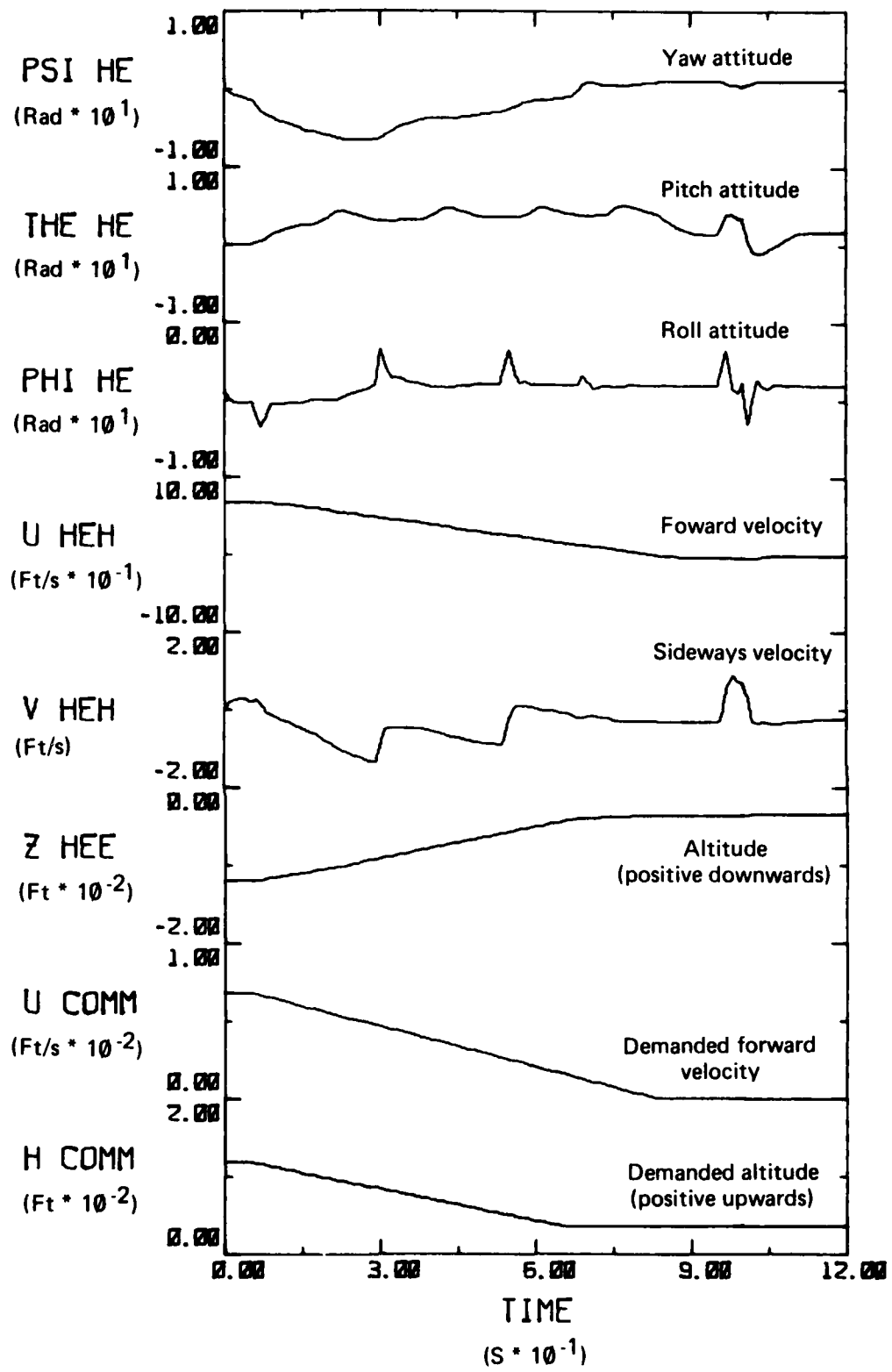

FIG 16A. MODERNIZED WESSEX: TIME HISTORIES FOR VARIABLES (TEST 1)

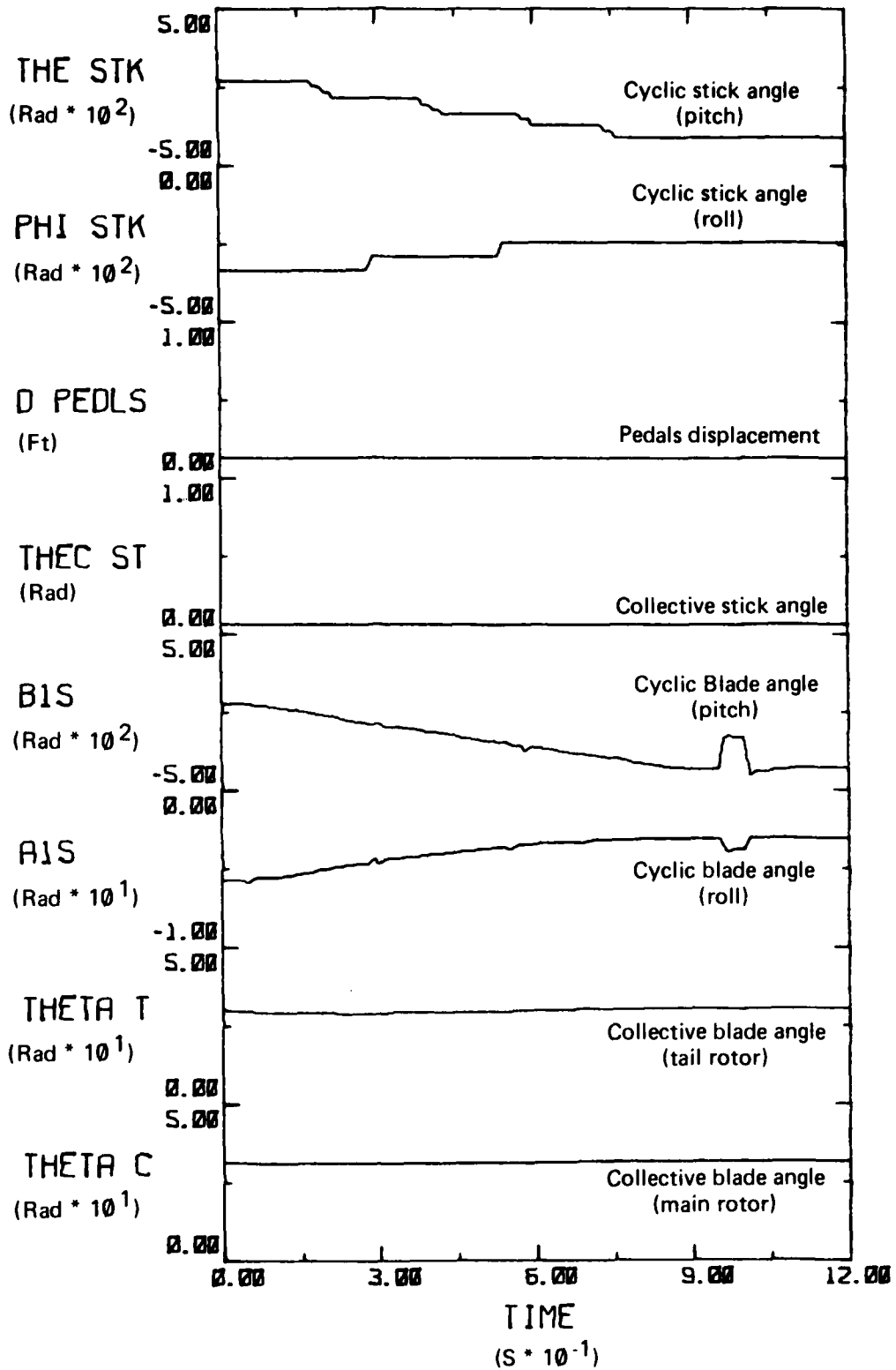

FIG 16B. MODERNIZED WESSEX: TIME HISTORIES FOR VARIABLES (TEST 1)

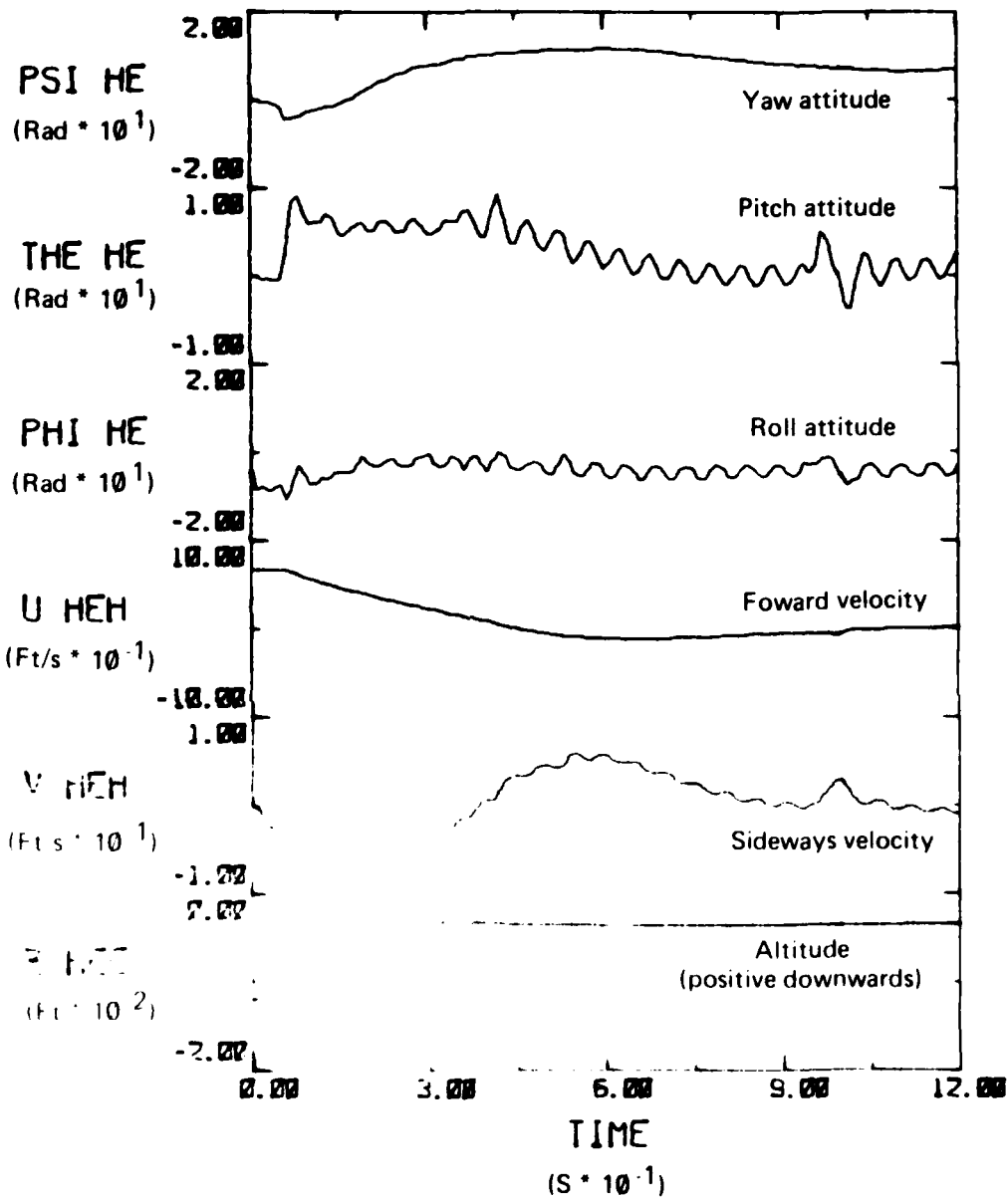

FIG 17A. WESSEX MK 313: TIME HISTORIES FOR VARIABLES (TEST 1)

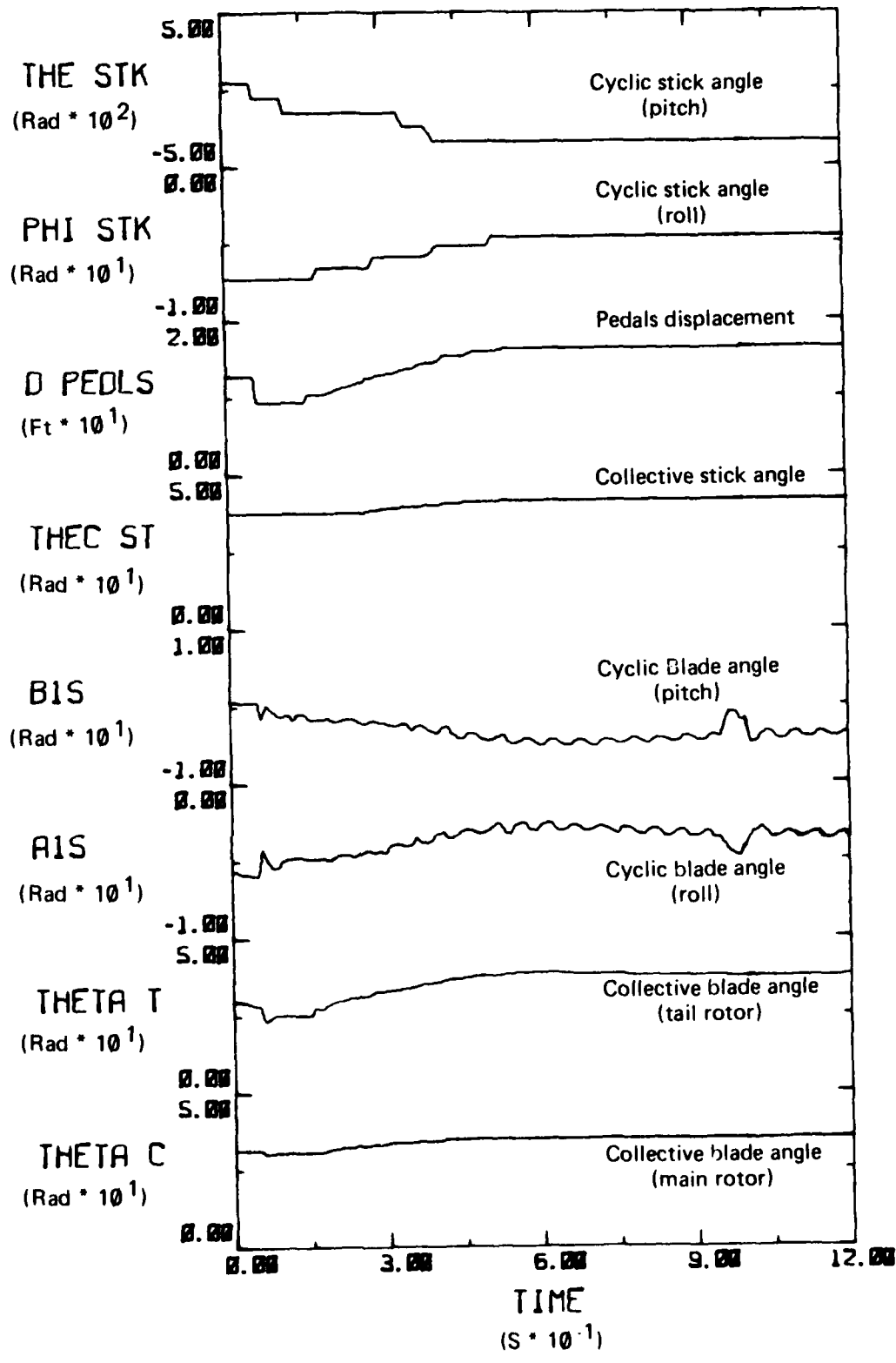

FIG 17B. WESSEX MK 31B: TIME HISTORIES FOR VARIABLES (TEST 1)

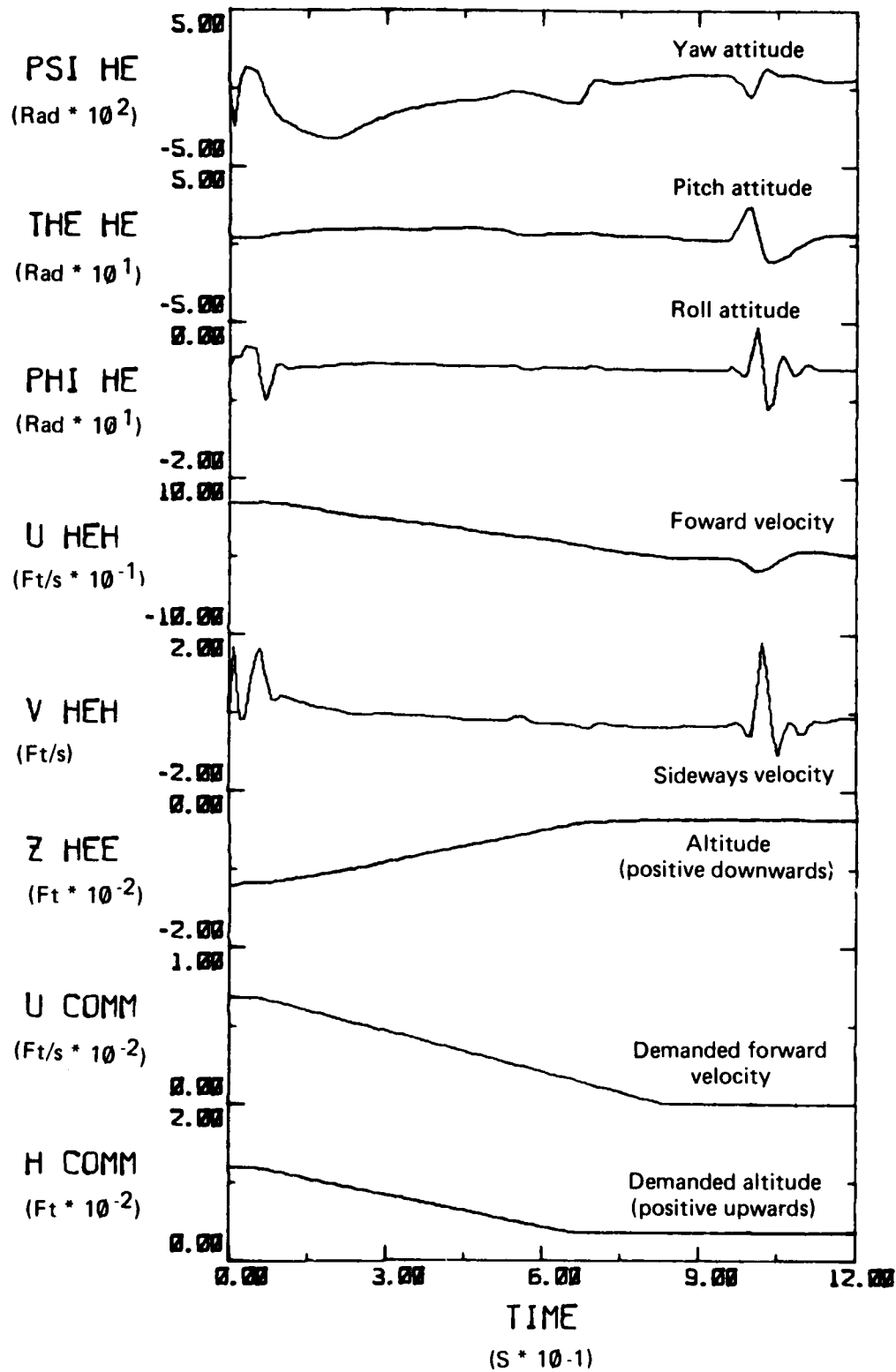

FIG 18A. SEA KING MK 50: TIME HISTORIES FOR VARIABLES (TEST 1)

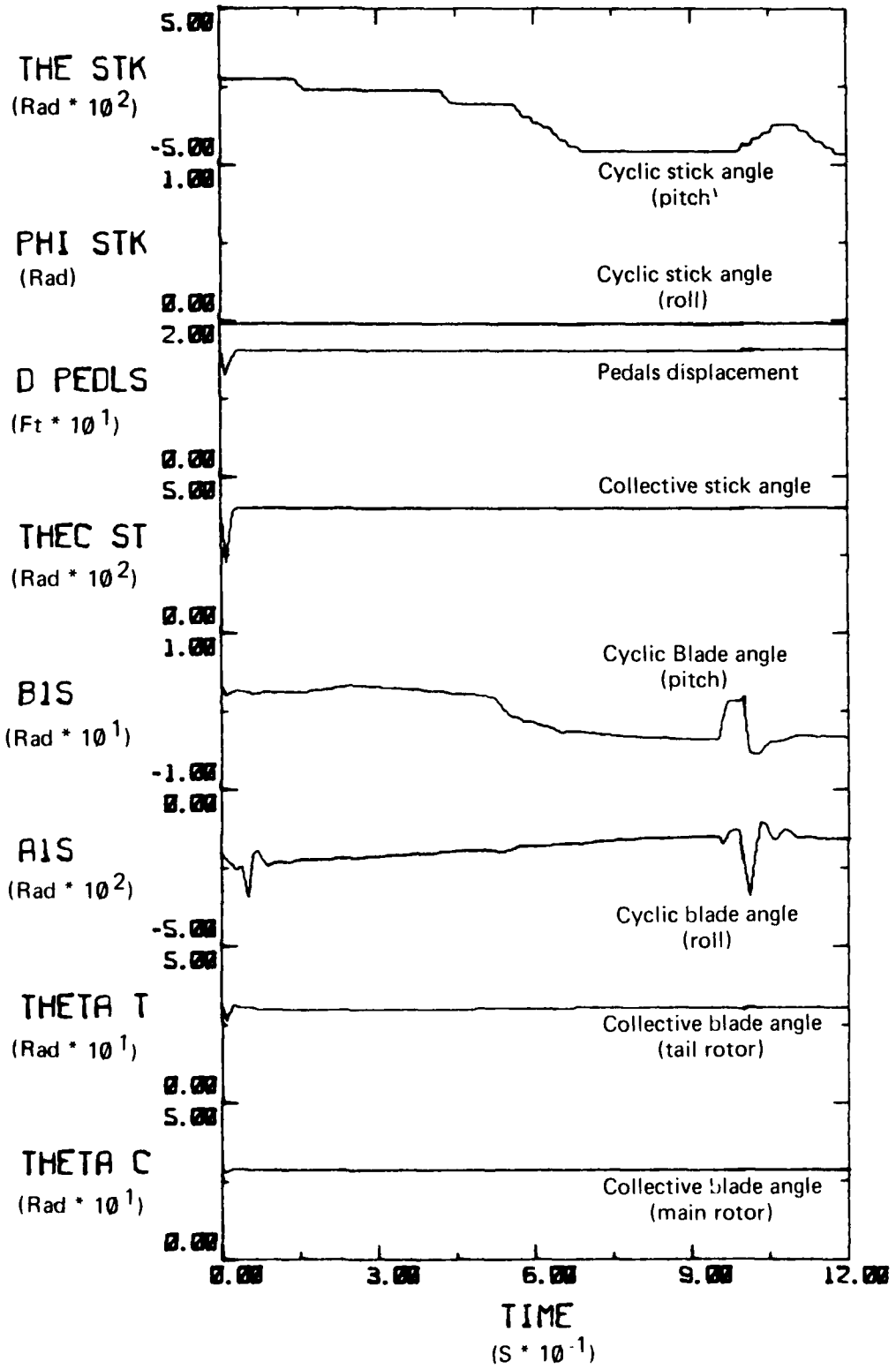

FIG 18B. SEA KING MK 50: TIME HISTORIES FOR VARIABLES (TEST 1)

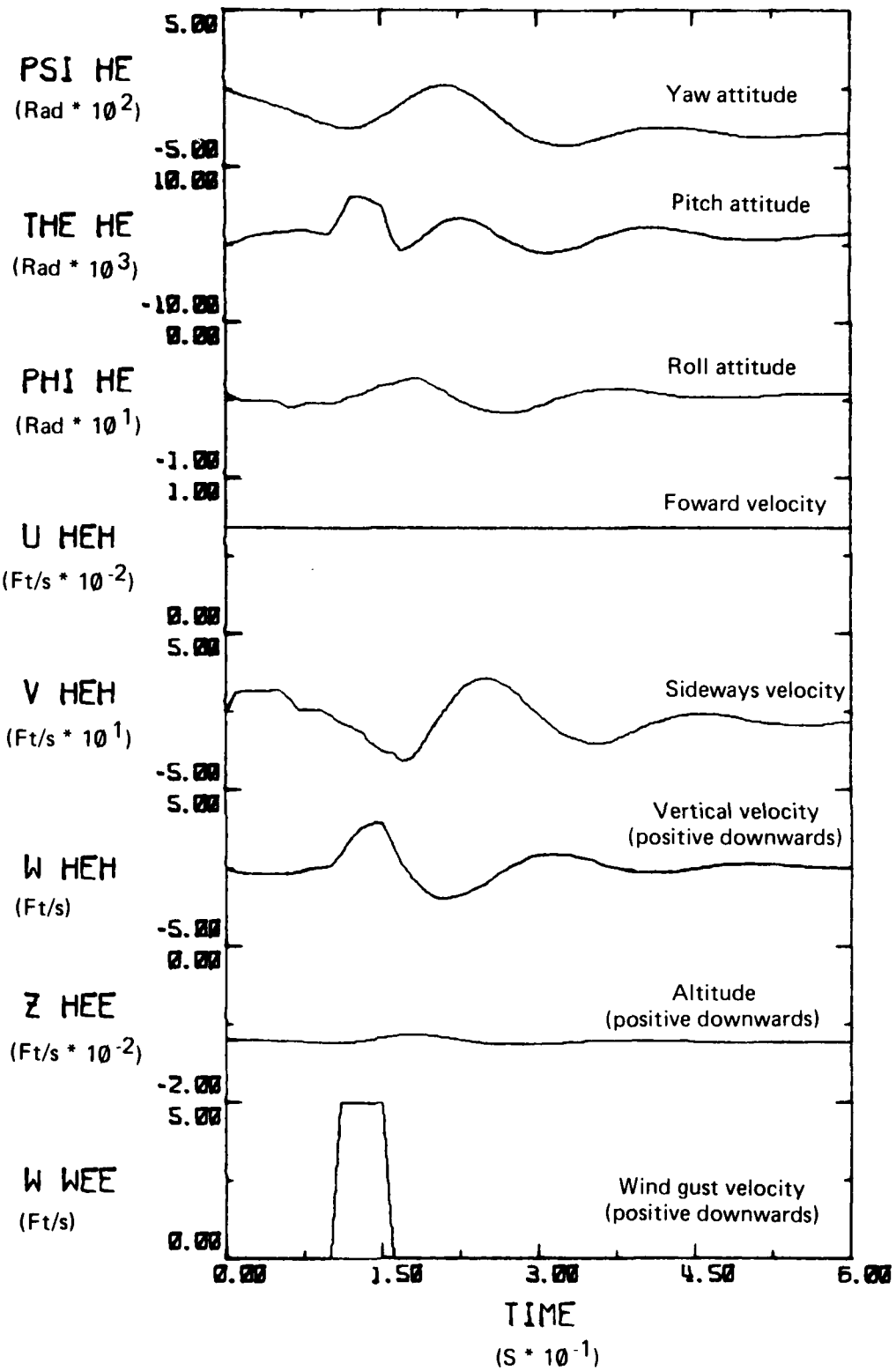

FIG 19. MODERNIZED WESSEX: TIME HISTORIES FOR VARIABLES (TEST 2)

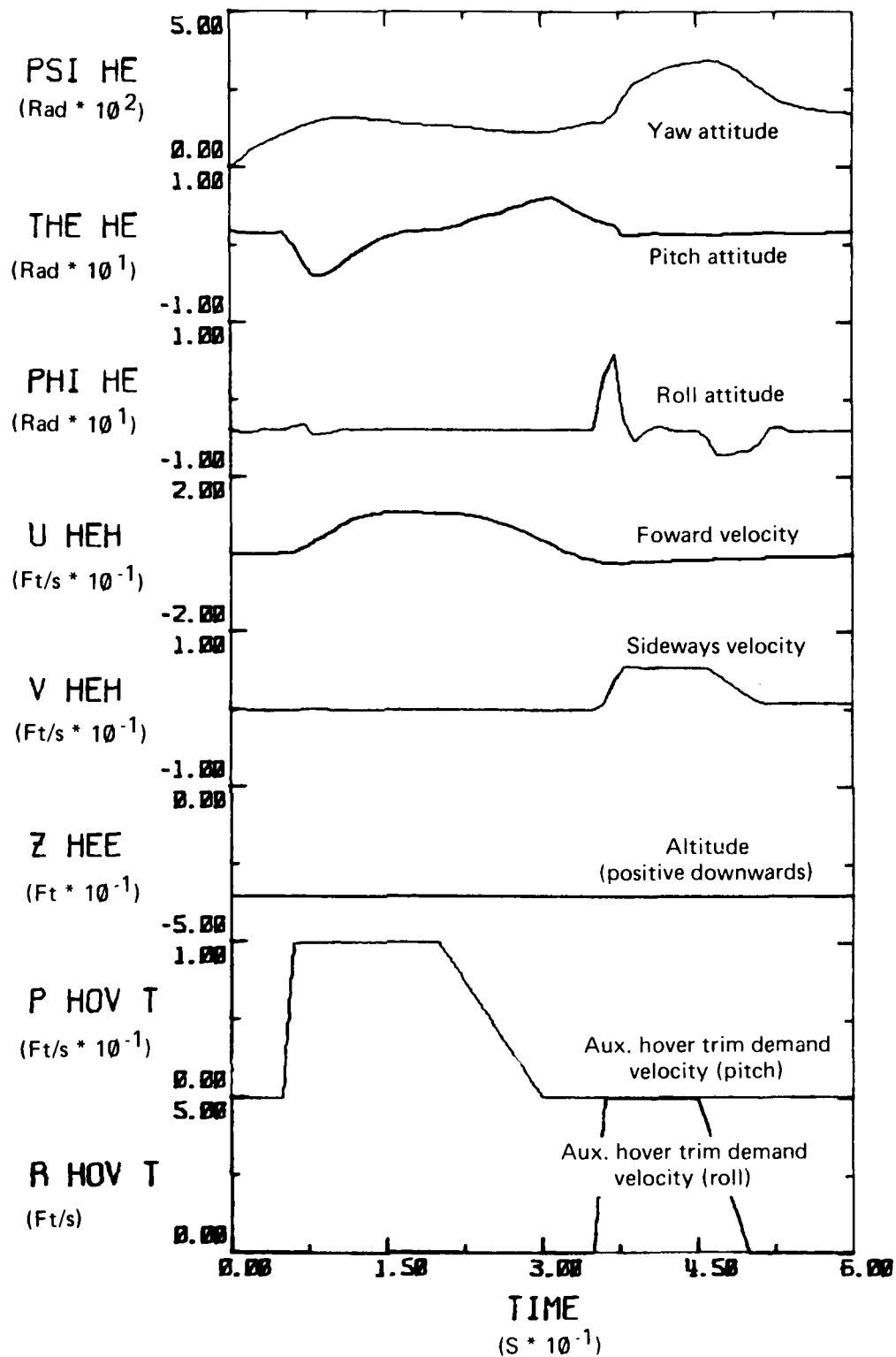

FIG 20. MODERNIZED WESSEX: TIME HISTORIES FOR VARIABLES (TEST 3)

DISTRIBUTION

Copy No.

AUSTRALIA

Department of Defence

Central Office

Chief Defence Scientist	1
Deputy Chief Defence Scientist	2
Superintendent, Science and Technology Programs	3
Defence Library	4
Australian Defence Scientific and Technical Representative (U.K.)	5
Counsellor, Defence Science (U.S.A.)	6
Joint Intelligence Organisation	7
Assistant Secretary, D.I.S.B.	8-23

Aeronautical Research Laboratories

Chief Superintendent	24
Library	25
Superintendent, Aerodynamics Division	26
Aerodynamics Divisional File	27
Author: C. R. Guy	28-29
D. C. Collis	30-33
D. A. Secomb	34
D. E. Hatton	35

Materials Research Laboratories

Library	36
---------	----

Defence Research Centre, Salisbury

Library	37
---------	----

Central Studies Establishment

Information Centre	38
--------------------	----

Engineering Development Establishment

Library	39
---------	----

RAN Research Laboratory

Library	40
---------	----

Navy Office

Naval Scientific Adviser	41
Director of Naval Aircraft Engineering	42
Director of Naval Aviation Policy	43
AMAFTU, Nowra	44

Army Office

Army Scientific Adviser	45
Royal Military College	46
US Army Standardisation Group	47

Air Force Office

Air Force Scientific Adviser	48
Aircraft Research and Development Unit	49

Engineering (CAFTS) Library	50
D. Air Eng.-AF	51
HQ Support Command (SENGSO)	52
Department of Productivity	
Government Aircraft Factories	
Library	53
Department of Transport	
Director-General/Library	54
Statutory, State Authorities and Industry	
Commonwealth Aircraft Corporation	
Manager	55
Hawker de Havilland Pty Ltd	
Librarian, Bankstown	56
Manager, Lidcombe	57
Universities and Colleges	
Sydney Professor G. A. Bird, Aeronautical Engineering	58
RMIT Mr H. Millicer, Aeronautical Engineering	59
CANADA	
NRC, National Aeronautics Establishment, Library	60
FRANCE	
AGARD Library	61
ONERA Library	62
Service de Documentation Technique de L'Aeronautique	63
INDIA	
Hindustan Aeronautics Ltd, Library	64
National Aeronautical Laboratory (Director)	65
NETHERLANDS	
National Aerospace Laboratory (NLR) Library	66
UNITED KINGDOM	
Aeronautical Research Council NPL (Secretary)	67
Royal Aircraft Establishment Library, Farnborough	68
Royal Aircraft Establishment Library, Bedford	69
Westland Helicopters Ltd	70
UNITED STATES OF AMERICA	
NASA Scientific and Technical Information Facility	71
American Institute of Aeronautics and Astronautics	72
Spares	73-87