

AD-A087 845

HONEYWELL INC HOPKINS MN  
THE MINI-REFRACTIONSONDE SYSTEM (MRS) FOR MEASURING REFRACTIVE --ETC(U)  
JUN 79 C D NOTCHENBACHER

F/G 20/6

UNCLASSIFIED

GIDEP-E164-0689

NL

1 OF 1

SEARCHED



END

DATE

FILED

9-80

DTIC

# LEVEL

12/6

18 GIVEM 17

11 4x47

## THE MINI-REFRACTIONSONDE SYSTEM (MRS) FOR MEASURING REFRACTIVE INDEX

AUG 14 1980

10 Curtis D. Motchenbacher

Honeywell, Inc.

Hopkins, Minnesota 55343

A

ADA 087845

### 1. INTRODUCTION

The Navy has a requirement to measure the vertical profile of index-of-refraction from sea level to above 15,000 feet. It is necessary to make these measurements from many classes of ships under typical operating conditions. To fill this need, a light-weight balloon sonde and processor (mini-refractionsonde system) is being developed by Honeywell under contract from Naval Air Development Center and sponsored by Naval Air Systems Command (AIR-370).

This paper discusses the mini-refractionsonde program plan and status. The development of the sonde, ground station, balloon filling and handling equipment are described. Discussions on utilization of the sonde are included.

### 2. BACKGROUND

The principal purpose of the mini-refractionsonde program is to develop a system for measuring the altitude and strength of atmospheric inversion layers. Near a land mass, these layers will create cells of atmosphere that are homogeneous over a distance of 10 to 20 miles. These cells create holes or ducts for radar signals. For shipboard radars this can greatly extend the range of radar detection along the surface, but can create elevated holes in the radar coverage. Communications signals are also affected by the inversion layers. This is particularly a problem when trying to communicate from surface ships to aircraft aloft.

There are three difficulties in measuring atmospheric refractivity from a shipboard environment. First it is desirable to measure refractivity in localized areas of 10 to 20 miles. Second it is necessary to make the measurements while operating in a confined shipboard space. Third, it is necessary to operate in a high radar and RF interference environment.

A solution to the problem of measuring atmospheric refractivity from a shipboard environment is to develop a small light-weight miniature balloon sonde that can be launched with small 30 gram or 100 gram pibal balloons. Because of the smaller balloon it is possible to launch the sondes from ships such as destroyers and frigates where conventional sonde launching capabilities are not available. For ease of handling, the equipment is made semi-automated for one man operation. The system is one-man portable for transfer from ship to ship. This way data can be obtained over a wide area as the ship is

deployed. The telemetry system is being made RF tolerant so it will operate in an EMI and radar environment.

### 3. DESCRIPTION OF DEVELOPMENT

#### 3.1 Mini-Refractionsonde

The function of the sonde is to measure temperature and humidity versus altitude so refractive index can be calculated.

A VIZ premium rod thermistor is used for temperature measurement over the range of -95°C to +55°C. A VIZ premium carbon hygistor is used for humidity measurement over the range of 0 to 100 percent RH.

For pressure measurement, a Honeywell silicon diaphragm barometer is used. This device was originally developed for measuring altitude in commercial aircraft. The miniature pressure sensor consists of a 0.1 inch square silicon chip with strain sensitive resistors diffused into the surface of a one mil thick diaphragm. The back of the sensor is mounted on an evacuated tube to measure absolute pressure. The diaphragm is normally deflected by atmospheric pressure on the front of the diaphragm. As the pressure changes the diaphragm deflection decreases giving a change in reading on the diffused piezoresistive sensors. The altitude and pressure change is read out as a varying DC voltage. The pressure sensor has a basic accuracy of 5 millibars and has a reproducible accuracy of much better than one millibar. The resolution and hysteresis are much better than 0.1 millibar. The barometers are calibrated to one millibar and an overall accuracy of approximately 1.5 millibar over the pressure range of 0 to 1,050 millibars is expected. The barometer is capable of operating to greater than 10 atmospheres. This light-weight low cost barometer is the technological breakthrough that allowed the development of a light-weight mini-sonde.

A cut-away view of the mini-refractionsonde is shown in Figure 1. The sensors are mounted at the top in an air duct. Inside the case are located the meteorological electronics, the NAVAID receiver for wind sensing, the battery power supply, and telemetry transmitter. The antenna projects from the bottom of the case.

DDC FILE COPY

81 170 170

DISTRIBUTION STATEMENT A  
Approved for public release;  
Distribution is unlimited.

10  
2

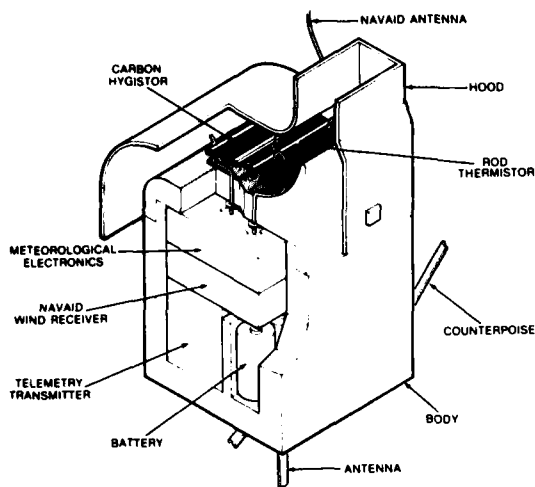

Figure 1. Mini-Refraktionssonde, Cutaway

The sensor signals are commutated by an integrated electronics package which commutates at a 10 cycle per second rate. This gives an output of a high reference and all three sensor signals every 0.4 second. At a vertical ascent rate of 700 feet per minute, this gives a complete data frame every five feet of vertical ascent. The sensor voltage signals are converted to audio frequencies in the range of 200 to 2500 hertz by a linear voltage-to-frequency converter. These frequencies are telemetered to the ground station processor by an FM telemetry transmitter. The transmitter operates with 1/2 watt of power in the 400 to 406 megahertz meteorological telemetry band. Frequency modulation minimizes interference from other radio frequency sources. The telemetry transmitter antenna is a quarter wave ground plane antenna to give omnidirectional signal radiation.

Power for the mini-sonde is provided by three lithium/sulfur dioxide cells. These cells each weigh 12 grams and will power the sonde for approximately two hours of operation. This is sufficient time for an ascent to 90,000 feet using a 300 gram balloon or to 20,000 feet using a 30 gram balloon. The cells are available either from PR Mallory & Company or from Honeywell's Power Sources Center. The development of high energy light-weight cells that can operate at 0°C has been a real boon to the mini-refraktionssonde program.

The case for the sonde is made of molded styrofoam for light-weight and insulation. The upper hood shown in Figure 1 can be removed for insertion of the carbon hygistor. When the hood is placed on top of the sonde it forms a duct that increases the air flow past the hygistor to 1.8 times the vertical ascent velocity. This improves the carbon hygistor time-constant. The hood is metallized to eliminate solar effects on the carbon hygistor.

### 3.2 Ground Station

A drawing of the intended ground station is shown in Figure 2. The ground station consists of an antenna, preamplifier, telemetry receiver, micro-processor and printer. The present shipboard 400 megahertz dipole ground plane antennas will be used

for the mini-refraktionssonde system. A preamplifier and filter will be mounted at the antenna to improve telemetry range and interference signal rejection.

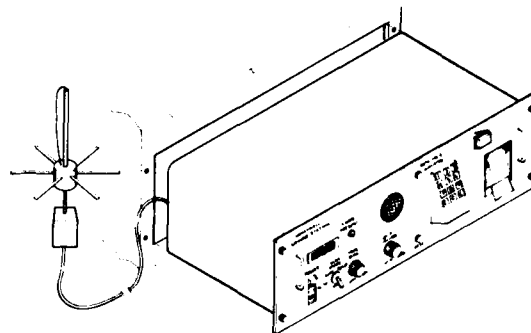

Figure 2. Ground Station

A special telemetry receiver has been developed to receive the meteorological signals in the presence of a high EMI environment. The receiver has high skirt rejection for out-of-band signals and a high intermodulation intercept point to reject in-band signal interference. Large radar pulses that overload the receiver are automatically blanked for the duration of the interference pulse. The receiver has automatic track-and-lock so that it will search for the sonde telemetry signal, lock-on and track the signal if the transmitter frequency drifts.

When the receiver is operated in the automatic mode it will scan for a signal until a sonde is acquired. If no signal is detected it will continue scanning until one is found. If the signal detected is not from a sonde, the processor will inform the receiver to continue scanning for a sonde signal.

The data processor consists of three micro-processor chips. The first microprocessor is concerned with telemetry receiver control and data reception. This first processor reads the sonde signal during each 0.1 second commutation, and passes the frequency on to the second processor. The second processor calculates the temperature, pressure and humidity using a dedicated arithmetic microprocessor. This second processor automatically analyzes the data, looking for inflection points in the temperature and humidity profiles. The output consists of a report of all of the significant levels as well as the mandatory levels required by the WMO format. A complete dump of all the sonde data is available on-line as the signals are being received.

The data is outputted on a 40 character wide ruggedized printer. The output is either in refractivity format or WMO format.

The mini-sonde does not require baselining. The sonde comes with lock-in values for the thermistor, hygistor and barometer stored in a PROM. Prior to launch, the PROM is inserted in the ground station processor. This automatically inputs all of the calibration data for the sonde into the calculation algorithms. If the PROM is lost or damaged, a set of nominal values are stored in the processor memory so the sonde can be used with

slightly degraded accuracy. A 12 button keyboard inputs launch altitude and launch location.

The ground station will be made for permanent mount or portable operation. The unit will be mountable in a standard 19-inch rack or in a water-proof carrying case. For ease of maintainability, the same units are used for permanent and mobile operation so they can be interchanged in case of breakdown.

The telemetry receiver can be operated in a manual mode with the front panel controls. A speaker is provided for monitoring the sonde telemetry signal. This may prove useful in accessing possible interference sources. A digital frequency display is provided.

### 3.3 Balloon Filling and Handling Equipment

To ease the task of balloon filling and insure inflation accuracy, an automatic balloon inflation device was constructed. The automatic filling mechanism is shown in Figure 3. The balloon is attached to a cup and hooked to a lever arm. As the balloon fills, it raises the lever arm and rotates the cam turning off the helium supply. If a greater free-lift is desired, the balloon is moved to a shorter lever arm. This requires a greater lifting force to turn off the helium. Either 300 or 100 gram balloons can be inflated by using their respective holes.

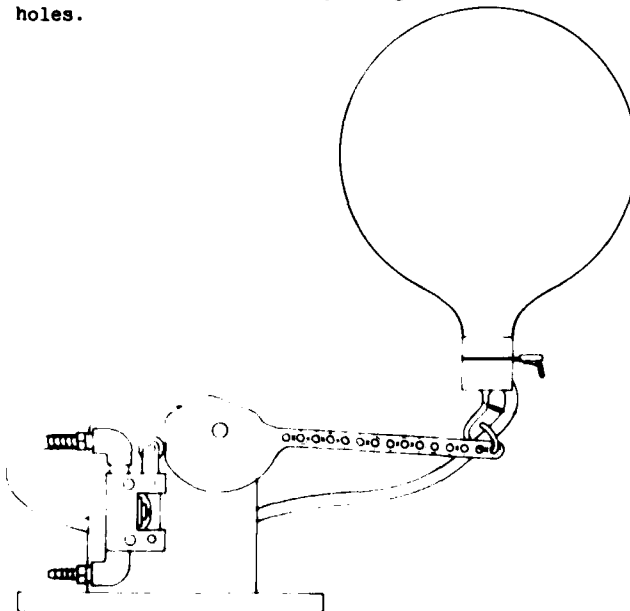

Figure 3. Balloon Filling Mechanism

For ease of handling a nylon shroud is placed over the balloon. Since the balloon is approximately 30 inch diameter it will pass through a standard hatchway door. The nylon shroud minimizes damage due to brushing against the door or overhead pipes. A covering shroud will be provided with each case of sondes.

After the balloon has been filled, the neck is tied using the cable tie strip shown in Figure 4. The sonde is supported by a harness line. The line is wrapped around a light-weight disposable train regulator. On the end of the line is a connector

that inserts into the balloon tie strap, attaching the sonde to the balloon without making any knots.

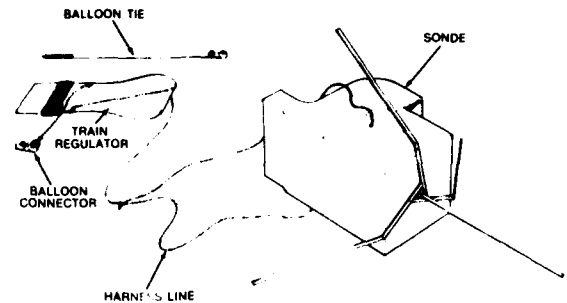

Figure 4. Launch Assembly

### 4. OPERATION WITH THE MINI-REFRACTIONSONDE SYSTEM

A typical operational sequence for a mini-refractionsonde launch is listed in Table 1. Except for the balloon filling and sonde launch, the operation is totally automatic. There is no baselining of the sonde, only the launch altitude must be entered. As the sonde is activated the receiver will automatically acquire and track the telemetry frequency. As the sonde is launched, the processor will detect the rise in altitude and begin the data processing. As the sonde ascends the refractive profile will be calculated and reported as each significant level is reached. When the balloon bursts and the sonde begins to descend, the processor will terminate the message.

TABLE 1. OPERATIONAL SEQUENCE

- o TURN "ON" GROUND STATION POWER
- o UNWRAP SONDE & BALLOON
- o INSERT ROM IN PROCESSOR
- o ENTER LAUNCH ALTITUDE
- o FILL & TIE BALLOON
- o PLACE COVER ON BALLOON
- o OPEN HYGRISTOR CAN & INSERT IN SONDE
- o CHECK FOR "DATA RECEIVED" LIGHT
- o ATTACH SONDE TO BALLOON
- o CARRY BALLOON & SONDE ON DECK
- o RELEASE BALLOON & SONDE
- o REFRACTIVITY MESSAGE BEGINS IMMEDIATELY
- o COMPLETE MESSAGE IN 15 to 30 MINUTES

Some of the advantages of the mini-refractionsonde system compared to the present system are tabulated in Table 2. These advantages are primarily in the ease of operation and the reduction of the number of personnel required for launch. The amount of helium required for a typical operation is also significantly reduced.

TABLE 2. MRS ADVANTAGES

	PRESENT SYSTEM	MRS
LAUNCH PERSONNEL REQUIRED	3	1
TIME FOR A SOUNDING	3 HRS.	45 MINS.
BASELINE OF SONDE	YES	NO
AUTOMATIC DATA REDUCTION	NO	YES
BALLOONS FILLED/TANK	2-1/2	40

There is a cost savings in making a sounding only to the altitude required for the operation. A lower level sounding uses both a less expensive balloon and less helium. For soundings to 20,000 feet a 30 gram balloon can be used. A 100 gram balloon will carry the mini-sonde to 35,000 feet. A 300 gram balloon will provide a sounding to 90,000 feet.

Since most refractive anomalies occur below 10,000 feet, it is anticipated that the 30 gram balloon will be the primary ascent vehicle. If higher altitude soundings are desired, a larger balloon can then be selected.

5. WIND SENSING CAPABILITY

The Mini-Refractiosonde System does not presently measure winds aloft. There is a strong interest in incorporating wind sensing into the sonde. The sonde could be made into a wind sonde without the use of a tracking antenna by using the Omega NAVAIID station signals. The use of Omega for wind sensing was demonstrated by Honeywell for NADC using the AMT-22 dropsonde. This wind sensing system consists of an Omega receiver in the sonde that receives and retransmits the Omega signals to the ground processor. The addition of wind sensing to the sonde would increase the weight and cost of the sonde by less than 10 percent. There is no formal plan to incorporate wind sensing in the Mini-Refractiosonde System; however, wind sensing Omega receivers are being added to some of the sondes for demonstration purposes. It is hoped that wind sensing capabilities can be added to the mini-refractiosonde within this year's program.

6. MRS PROGRAM PLAN AND STATUS

A copy of the Mini-Refractiosonde System program plan is shown in Figure 5. The program is proceeding in two stages. The first stage to be completed in mid-1979, will cover the advanced development of the mini-sonde, ground station and launch support equipment. The mini-sonde has previously gone through two development cycles and this is the third iteration. During the first project, the feasibility of a 100 gram sonde was demonstrated. During the second step, lab tests and flight tests at Wallops Island demonstrated the capabilities of the sonde. This advanced development phase is directed at making a producible sonde.

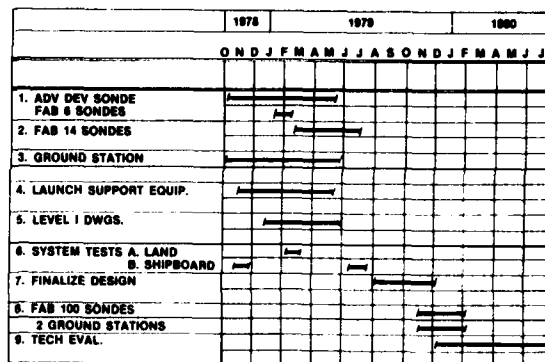

Figure 5. Mini-Refractiosonde System Program Plan

A ground station is being developed to automatically receive and process the telemetry signals from the sonde. A special RF telemetry receiver has been developed to receive the meteorological signals in the presence of radar interference. A micro-processor based ground station is being developed to provide on-line real-time data reduction and display. A ruggedized paper printer will output the data. The breadboard model of this ground station has been constructed and tested.

The launch support equipment consists of a method for filling and handling small balloons in a confined environment. The filling mechanism is a semi-automatic system to fill the balloon with helium to a predetermined nozzle lift. A model of the launch and fill mechanisms have been constructed and lab tested.

After the construction of 20 sondes, there will be a series of land tests in mid-1979 to demonstrate the operation of the mini-refractiosonde system. These tests will be conducted in an area with a high refractive anomaly probability. After successful completion of land tests of the sonde, further tests onboard an aircraft carrier will be conducted to demonstrate the system's operability under field operating conditions.

After successful demonstration of system operation under land and shipboard conditions, the Mini-Refractiosonde System will go through the final preproduction design phase in which any operational difficulties will be corrected. An additional quantity of 100 sondes and two ground stations will be constructed for use during TECHEVAL. TECHEVAL will take place during early 1980.

7. ACKNOWLEDGEMENTS

We would like to acknowledge the support of our sponsor, Mr. Ted Czuba of Naval Air Systems Command (AIR-370) and the contracting agent, Mr. Ed Schmidt of Naval Air Development Center. Thanks are also due to Lt. Commander Dan Gleavy for his support of our tests aboard the USS Ranger.

GOVERNMENT-INDUSTRY DATA EXCHANGE PROGRAM

# GENERAL DOCUMENT SUMMARY SHEET

1 OF 1

Please Type All Information - See Instructions on Reverse

1. ACCESS NUMBER <b>E164-0689</b>		2. COMPONENT/PART NAME PER GIDEP SUBJECT THESAURUS <b>Environmental Studies, Analysis</b>	
3. APPLICATION <b>Engineering</b>		4. MFR NOTIFICATION <input type="checkbox"/> NOTIFIED <input checked="" type="checkbox"/> NOT APPLICABLE	
5. DOCUMENT ISSUE (Month/Year) <b>June 1979</b>		6. DOCUMENT TYPE <input checked="" type="checkbox"/> GEN RPT <input type="checkbox"/> NONSTD PART <input type="checkbox"/> SPEC	
7. ORIGINATOR'S DOCUMENT TITLE <b>The Mini-Refractiosonde System (MRD) for Measuring Refractive Index</b>		8. ORIGINATOR'S DOCUMENT NUMBER <del>NOSS TD 060</del>	
9. ORIGINATOR'S PART NAME/IDENTIFICATION <b>None</b>		10. DOCUMENT (SUPERSEDES) (SUPPLEMENTS) ACCESS NO. <b>None</b>	
11. ENVIRONMENTAL EXPOSURE CODES <b>N/A</b>		12. MANUFACTURER <b>N/A</b>	
13. MANUFACTURER PART NUMBER <b>----</b>		14. INDUSTRY/GOVERNMENT STANDARD NUMBER	

15. OUTLINE, TABLE OF CONTENTS, SUMMARY, OR EQUIVALENT DESCRIPTION

The Navy has a requirement to measure the vertical profile of index-of-refraction from sea level to above 15,000 feet. It is necessary to make these measurements from many classes of ships under typical operating conditions. To fill this need, a light-weight balloon sonde and processor (mini-refractiosonde system) is being developed by Honeywell under contract from Naval Air Systems Command (AIR-370).

The paper discusses the mini-refractiosonde program plan and status. The development of the sonde, ground station, balloon filling and handling equipment are described. Discussions on utilization of the sonde are included.

Accession For	
NTIS Class	<input checked="" type="checkbox"/>
DOC Tab	<input checked="" type="checkbox"/>
Unannounced	<input type="checkbox"/>
Justification	<input type="checkbox"/>
By	
Availability Codes	
Dist	Avail and/or special
<b>A</b>	

**80 2 5 359**

16. GIDEP INDEXING <b>Index of Refraction; Balloon Sonde; Mini-Refractiosonde (Doc Des--P)</b>	
17. GIDEP REPRESENTATIVE <b>Joseph Hirsch</b>	18. PARTICIPANT ACTIVITY AND CODE <b>USN Ocean Systems Center, San Diego, CA (Y3)</b>