

AD-A087 921

NEW JERSEY DEPT OF ENVIRONMENTAL PROTECTION TRENTON F/6 13/13  
NATIONAL DAM SAFETY PROGRAM, N.J. NO NAME DAM NUMBER 40 (NJ0629--ETC(U)  
MAR 80 J P TALERICO DACW61-79-C-0011  
NL

UNCLASSIFIED

Line 1  
AD  
A087 921

END  
DATE  
FILMED  
9-80  
DTIC

**LEVEL**

PASSAIC RIVER BASIN  
BRANCH OF POST BROOK,  
PASSAIC COUNTY  
NEW JERSEY

(C)  
B.S.

AD A087921

**N.J. NO NAME DAM  
NO. 40**

**NJ 00208**

**PHASE 1 INSPECTION REPORT  
NATIONAL DAM SAFETY PROGRAM**

DACW 61-79-C-0011



SDTIC  
E.  
AUG 13 1980  
C

APPROVED FOR PUBLIC RELEASE;  
DISTRIBUTION UNLIMITED.

DEPARTMENT OF THE ARMY

Philadelphia District  
Corps of Engineers  
Philadelphia, Pennsylvania

DDG FILE COPY

MARCH 1980  
APPROVED FOR PUBLIC RELEASE;  
DISTRIBUTION UNLIMITED.

80 8 11 188

REPORT DOCUMENTATION PAGE		READ INSTRUCTIONS BEFORE COMPLETING FORM
1. REPORT NUMBER NJ00208	2. GOVT ACCESSION NO. AD-A087921	3. RECIPIENT'S CATALOG NUMBER
4. TITLE (and Subtitle) Phase I Inspection Report National Dam Safety Program NJ No Name Dam No. 40 NJ00208 Passaic County, New Jersey		5. TYPE OF REPORT & PERIOD COVERED  FINAL
		6. PERFORMING ORG. REPORT NUMBER
7. AUTHOR(s)  JOHN P. TALERICO		8. CONTRACT OR GRANT NUMBER(s) DACW61-79-C-0011 ✓
9. PERFORMING ORGANIZATION NAME AND ADDRESS Frederic R. Harris, Inc. 453 Amboy Ave. Woodbridge, N.J. 07095		10. PROGRAM ELEMENT, PROJECT, TASK AREA & WORK UNIT NUMBERS
11. CONTROLLING OFFICE NAME AND ADDRESS NJ Department of Environmental Protection ✓ Division of Water Resources P.O. Box CN029 Trenton, NJ 08625		12. REPORT DATE March, 1980
		13. NUMBER OF PAGES 84
14. MONITORING AGENCY NAME & ADDRESS (if different from Controlling Office) U.S. Army Engineer District, Philadelphia Custom House, 2d & Chestnut Streets Philadelphia, PA 19106		15. SECURITY CLASS. (of this report)  Unclassified
		15a. DECLASSIFICATION/DOWNGRADING SCHEDULE
16. DISTRIBUTION STATEMENT (of this Report)  Approved for public release; distribution unlimited.		
17. DISTRIBUTION STATEMENT (of the abstract entered in Block 20, if different from Report)		
18. SUPPLEMENTARY NOTES  Copies are obtainable from National Technical Information Service, Springfield, Virginia 22151.		
19. KEY WORDS (Continue on reverse side if necessary and identify by block number)		
Dams Embankments Structural Analysis Visual Inspection	National Dam Safety Program N.J. No Name Dam No. 40, New Jersey Spillways Seepage	Erosion
20. ABSTRACT (Continue on reverse side if necessary and identify by block number) This report cites results of a technical investigation as to the dam's adequacy. The inspection and evaluation of the dam is as prescribed by the National Dam Inspection Act, Public Law 92-367. The technical investigation includes visual inspection, review of available design and construction records, and preliminary structural and hydraulic and hydrologic calculations, as applicable. An assessment of the dam's general condition is included in the report.		



IN REPLY REFER TO  
NAPEN-N

DEPARTMENT OF THE ARMY  
PHILADELPHIA DISTRICT, CORPS OF ENGINEERS  
CUSTOM HOUSE—2 D & CHESTNUT STREETS  
PHILADELPHIA, PENNSYLVANIA 19106

C

Honorable Brendan T. Byrne  
Governor of New Jersey  
Trenton, New Jersey 08621

05 AUG 1980

Dear Governor Byrne:

Inclosed is the Phase I Inspection Report for N.J. No Name Dam No. 40 in Passaic County, New Jersey which has been prepared under authorization of the Dam Inspection Act, Public Law 92-367. A brief assessment of the dam's condition is given in the front of the report.

Based on visual inspection, available records, calculations and past operational performance, N.J. No Name Dam No. 40, a high hazard potential structure, is judged to be in poor overall condition. In addition, the spillway is considered seriously inadequate because a flow equivalent to twelve percent of the Probable Maximum Flood (PMF) would cause the dam to be overtopped. The seriously inadequate spillway is assessed as an UNSAFE, non-emergency condition, until more detailed studies prove otherwise or corrective measures are completed. The classification of UNSAFE applied to a dam because of a seriously inadequate spillway is not meant to indicate the same degree of emergency as would be associated with an UNSAFE classification applied for a structural deficiency. It does mean, however, that based on an initial screening, and preliminary computations, there appears to be a serious deficiency in spillway capacity so that if a severe storm were to occur, overtopping and failure of the dam would take place, significantly increasing the hazard of loss of life downstream from the dam. To ensure adequacy of the structure, the following actions, as a minimum, are recommended.

a. The spillway's adequacy should be determined by a qualified professional consultant engaged by the owner using more sophisticated methods, procedures and studies within six months from the date of approval of this report. The ability of the dam to withstand overtopping should also be studied. Within three months of the consultant's findings, remedial measures to ensure spillway adequacy should be initiated. In the interim, a detailed emergency operation plan and warning system should be promptly developed. Also, during periods of unusually heavy precipitation, around the clock surveillance should be provided.

This document has been approved  
for public release and sale; its  
distribution is unlimited.

NAPEN-N

Honorable Brendan T. Byrne

b. Within six months from the date of approval of this report, the following engineering studies and analyses should be initiated:

(1) Observation wells or piezometers should be installed in the embankment to determine the location of the phreatic surface and the paths of the seepage observed. This should be done within six months.

(2) The flow of the seepage should be monitored monthly to determine its volume and whether it presents a problem to the safety of the dam.

c. The following remedial measures should be completed within twelve months from the date of approval of this report:

(1) Repair all cracked and spalled concrete.

(2) All brush and trees should be removed from the downstream and upstream slopes to avoid problems which may develop from roots. The embankment face should then be seeded to develop a growth of grass for surface erosion protection.

(3) Provide a headwall and side slope and channel bottom protection for both the approach and discharge channels. Extend the protection for the discharge channel to beyond the embankment toe of slope, provided the pipe is not required to be replaced as a result of the hydrologic and hydraulic analysis of the dam.

(4) Construct channels to carry the discharge from the spillway and the low-level outlet to the existing downstream channel.

(5) Remove the boulders from the discharge end of the low-level outlet, and provide a headwall and apron and a cover for the valve chamber.

d. Consider providing additional low-level outlet facilities to decrease drawdown time.

e. The owner should develop written operating procedures and a periodic maintenance plan to ensure the safety of the dam within one year from the date of approval of this report.

A copy of the report is being furnished to Mr. Dirk C. Hofman, New Jersey Department of Environmental Protection, the designated State Office contact for this program. Within five days of the date of this letter, a copy will also be sent to Congressman Roe of the Eighth District. Under the provision of the Freedom of Information Act, the inspection report will be subject to release by this office, upon request, five days after the date of this letter.

NAPEN-N

Honorable Brendan T. Byrne

Additional copies of this report may be obtained from the National Technical Information Services (NTIS), Springfield, Virginia 22161 at a reasonable cost. Please allow four to six weeks from the date of this letter for NTIS to have copies of the report available.

An important aspect of the Dam Inspection Program will be the implementation of the recommendations made as a result of the inspection. We accordingly request that we be advised of proposed actions taken by the State to implement our recommendations.

Sincerely,

*James G. Ton*  
JAMES G. TON  
Colonel, Corps of Engineers  
District Engineer

1 Incl  
As stated

Copies furnished:  
Mr. Dirk C. Hofman, P.E., Deputy Director  
Division of Water Resources  
N.J. Dept. of Environmental Protection  
P.O. Box CN029  
Trenton, NJ 08625

Mr. John O'Dowd, Acting Chief  
Bureau of Flood Plain Regulation  
Division of Water Resources  
N.J. Dept. of Environmental Protection  
P.O. Box CN029  
Trenton, NJ 08625

Accession For	
NTIS GRA&I	<input checked="" type="checkbox"/>
DDC TAB	<input type="checkbox"/>
Unannounced	<input type="checkbox"/>
Justification <i>See memo</i>	
<i>50 was file</i>	
By _____	
Distribution/	
Availability Codes	
Dist	Avail and/or special
<i>A</i>	

N.J. NO NAME DAM NO. 40 (NJ00208)

CORPS OF ENGINEERS ASSESSMENT OF GENERAL CONDITIONS

This dam was inspected on 21 November 1979 by Harris-ECI, Associates, Inc., under contract to the State of New Jersey. The State, under agreement with the U.S. Army Engineer District, Philadelphia, had this inspection performed in accordance with the National Dam Inspection Act, Public Law 92-367.

N.J. No Name Dam No. 40, a high hazard potential structure, is judged to be in poor overall condition. In addition, the spillway is considered seriously inadequate because a flow equivalent to twelve percent of the Probable Maximum Flood (PMF) would cause the dam to be overtopped. The seriously inadequate spillway is assessed as an UNSAFE, non-emergency condition, until more detailed studies prove otherwise or corrective measures are completed. The classification of UNSAFE applied to a dam because of a seriously inadequate spillway is not meant to indicate the same degree of emergency as would be associated with an UNSAFE classification applied for a structural deficiency. It does mean, however, that based on an initial screening, and preliminary computations, there appears to be a serious deficiency in spillway capacity so that if a severe storm were to occur, overtopping and failure of the dam would take place, significantly increasing the hazard of loss of life downstream from the dam. To ensure adequacy of the structure, the following actions, as a minimum, are recommended.

a. The spillway's adequacy should be determined by a qualified professional consultant engaged by the owner using more sophisticated methods, procedures and studies within six months from the date of approval of this report. The ability of the dam to withstand overtopping should also be studied. Within three months of the consultant's findings, remedial measures to ensure spillway adequacy should be initiated. In the interim, a detailed emergency operation plan and warning system should be promptly developed. Also, during periods of unusually heavy precipitation, around the clock surveillance should be provided.

b. Within six months from the date of approval of this report, the following engineering studies and analyses should be initiated:

(1) Observation wells or piezometers should be installed in the dam to determine the location of the phreatic surface and the paths of seepage observed. This should be done within six months.

(2) The flow of the seepage should be monitored monthly to determine whether it presents a problem to the safety of the dam.

The following remedial measures should be completed within twelve months from the date of approval of this report:

(1) Repair all cracked and spalled concrete.

(2) All brush and trees should be removed from the downstream and upstream slopes to avoid problems which may develop from roots. The embankment face should then be seeded to develop a growth of grass for surface erosion protection.

(3) Provide a headwall and side slope and channel bottom protection for both the approach and discharge channels. Extend the protection for the discharge channel to beyond the embankment toe of slope, provided the pipe is not required to be replaced as a result of the hydrologic and hydraulic analysis of the dam.

(4) Construct channels to carry the discharge from the spillway and the low-level outlet to the existing downstream channel.

(5) Remove the boulders from the discharge end of the low-level outlet, and provide a headwall and apron and a cover for the valve chamber.

d. Consider providing additional low-level outlet facilities to decrease drawdown time.

e. The owner should develop written operating procedures and a periodic maintenance plan to ensure the safety of the dam within one year from the date of approval of this report.

APPROVED: \_\_\_\_\_

*James G. Ton*  
JAMES G. TON

Colonel, Corps of Engineers  
District Engineer

DATE: \_\_\_\_\_



IN REPLY REFER TO  
NAPEN-N

DEPARTMENT OF THE ARMY  
PHILADELPHIA DISTRICT, CORPS OF ENGINEERS  
CUSTOM HOUSE - 2 D & CHESTNUT STREETS  
PHILADELPHIA, PENNSYLVANIA 19106

22 MAY 1980

Honorable Brendan T. Byrne  
Governor of New Jersey  
Trenton, NJ 08621

Dear Governor Byrne:

This is in reference to our ongoing National Program for Inspection of Non-Federal Dams within the State of New Jersey. N.J. No Name Dam No. 40 (Federal I.D. No. NJ00208), a high hazard potential structure, has recently been inspected. The dam is owned by Mr. John Kalas and is located on a branch of Post Brook in West Milford Township.

Using Corps of Engineers screening criteria, it has been determined that the dam's spillway is seriously inadequate because a flow equivalent to 12 percent of the Probable Maximum Flood would cause the dam to be overtopped. The seriously inadequate spillway is assessed as an UNSAFE, non-emergency condition, until more detailed studies prove otherwise, or corrective measures are completed. The classification of UNSAFE applied to a dam because of a seriously inadequate spillway is not meant to indicate the same degree of emergency as would be associated with an UNSAFE classification applied for a structural deficiency. It does mean, however, that based on an initial screening and preliminary computations, there appears to be a serious deficiency in spillway capacity so that if a severe storm were to occur, overtopping and failure of the dam could take place, significantly increasing the hazard potential to loss of life downstream from the dam. As a result of this UNSAFE determination, it is recommended that the dam's owner take the following measures within 30 days of the date of this letter:

- a. Engage the services of a qualified professional consultant to more accurately determine the spillway adequacy by using more detailed and sophisticated hydrologic and hydraulic analyses, and to recommend any remedial measures required to prevent overtopping of the dam.

NAPEN-N

Honorable Brendan T. Byrne

b. In the interim, a detailed emergency operation plan and downstream warning system should be promptly developed. Also, around the clock surveillance should be provided during periods of unusually heavy precipitation.

A final report on this Phase I Inspection will be forwarded to you within two months.

Sincerely,

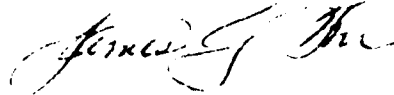

JAMES G. TON  
Colonel, Corps of Engineers  
District Engineer

**Copies Furnished:**

Mr. Dirk C. Hofman, P.E., Deputy Director  
Division of Water Resources  
N.J. Dept. of Environmental Protection  
P.O. Box CN029  
Trenton, NJ 08625

Mr. John O'Dowd, Acting Chief  
Bureau of Flood Plain Regulation  
Division of Water Resources  
N.J. Dept. of Environmental Protection  
P.O. Box CN029  
Trenton, NJ 08625

UNSAFE DAM  
NATIONAL PROGRAM OF INSPECTION OF DAMS

a. NAME: N.J. No Name Dam No. 40      b. ID NO.: NJ00208      c. LOCATION State: New Jersey, County: Passaic.  
d. HEIGHT: 15 feet      e. MAXIMUM IMPOUNDMENT CAPACITY: 226 ac. ft.  
River or Stream: Branch of Post Brook.  
Nearest D/S City or Town: West Milford.

f. TYPE: Earthfill.

g. OWNER: Mr. John Kalas.

h. DATE GOVERNOR NOTIFIED OF UNSAFE CONDITIONS:

i. CONDITION OF DAM RESULTING IN UNSAFE ASSESSMENT: Preliminary report calculations indicate 12% of the PMF would overtop the dam.

j. EMERGENCY CATEGORY: HIGH HAZARD, UNSAFE, Non-Emergency.

k. EMERGENCY ACTIONS TAKEN:

l. DESCRIPTION OF DANGER INVOLVED: Overtopping and failure of the dam would significantly increase hazard potential to loss of life and property downstream of dam.

m. REMEDIAL ACTIONS TAKEN:

n. RECOMMENDATIONS GIVEN TO GOVERNOR: Within 30 days of the date of the District Engineer's letter the owner should do the following:

o. REMARKS: Final report, to be issued within six weeks, will have WHITE cover.

- a. Engage the services of a qualified professional consultant to more accurately determine the spillway adequacy by using more detailed and sophisticated hydrologic and hydraulic analyses, and to recommend any remedial measures required to prevent overtopping of the dam.
- b. In the interim, a detailed emergency operation plan and downstream warning system should be developed. Also, around-the-clock surveillance should be provided during periods of unusually heavy precipitation.

T.B. HEVERIN, Coordinator  
Dam Inspection Program  
U.S.A.E.D., Philadelphia

PASSAIC RIVER BASIN  
BRANCH OF POST BROOK, PASSAIC COUNTY  
NEW JERSEY

9) Final rept.

11) Mar 1980

N.J. NO NAME DAM NO. 40

15) 172

NJ00208

6) PHASE I INSPECTION REPORT

NATIONAL DAM SAFETY PROGRAM N.J. No Name

Lia Number 48 (NJ00208), Passaic River  
Basin Branch of Post Brook, Passaic  
County, New Jersey.

10) J. P. / Talerico

15) DAM 43-11-E-0812

DEPARTMENT OF THE ARMY  
PHILADELPHIA DISTRICT, CORPS OF ENGINEERS  
PHILADELPHIA, PENNSYLVANIA 19106

MARCH 1980

424472 OK

PHASE I INSPECTION REPORT  
NATIONAL DAM SAFETY PROGRAM

Name: N.J. No Name Dam No. 40, I.D. NJ 00208  
State Located: New Jersey  
County Located: Passaic County  
Stream: Branch of Post Brook  
River Basin: Passaic River  
Date of Inspection: November 21, 1979

Assessment of General Conditions

N.J. No Name Dam No. 40 is an earthfill dam containing a 48-inch corrugated metal pipe through the embankment as a spillway at the left end of the dam. The overall condition of the dam is poor. There is no major sign of distress or instability in the embankment. A significant amount of seepage was observed along the downstream toe of the slope at the center of the dam. There is no slope or channel protection for either the approach or discharge channel of the spillway. There is no defined downstream channel for 200 to 300 feet from the embankment. The low-level outlet is in operable condition. The hazard potential is rated as "high".

The adequacy of N.J. No Name Dam No. 40 is considered questionable in view of its lack of spillway capacity to pass the SDF (1/2 PMF) without overtopping the dam. The spillway is capable of passing a flood equal to 11 percent of the PMF (22 percent of the 1/2 PMF), and is assessed as "seriously inadequate".

At present, the engineering data available is not sufficient to make a definitive statement on the stability of the dam, but based on the findings of the visual inspection, the preliminary assessment of static stability is that it is satisfactory. The following actions are recommended along with a timetable for their completion. All recommended actions should be conducted under the supervision of an Engineer who is experienced in the design, construction and inspection of dams.

1. Carry out a more precise hydrologic and hydraulic analysis of the dam within twelve months, to determine the need and type of mitigating measures necessary. Based on the results of these studies, remedial measures should be instituted. This should include the installation of a tailwater gage.

2. Observation wells or piezometers should be installed in the embankment to determine the location of the phreatic surface and the paths of the seepage observed. This should be done within six months.
3. The flow of seepage should be monitored monthly to determine its volume and whether it presents a problem to the safety of the dam.
4. Repair all cracked and spalled concrete within twelve months.
5. All brush and trees should be removed from the downstream and upstream slopes to avoid problems which may develop from roots. The embankment face should then be seeded to develop a growth of grass for surface erosion protection. This program should be started within twelve months.
6. Provide a headwall and side slope and channel bottom protection for both the approach and discharge channels. Extend the protection for the discharge channel to beyond the embankment toe of the slope. This should be completed within twelve months, providing the pipe is not required to be replaced as a result of the hydrologic and hydraulic analysis of the dam. (Ref. Item 1).
7. Construct channels to carry the discharge from the spillway and the low-level outlet to the existing downstream channel within twelve months.
8. Remove the boulders from the discharge end of the low-level outlet and provide a headwall and apron, and a cover for the valve chamber within twelve months.
9. The owner should develop an emergency action plan (if one is not already available) outlining actions to be taken by the operator to minimize downstream effects of an emergency and establish a flood warning system for the downstream communities within three months.

Furthermore, while of a less urgent nature, the following additional action is recommended and should be carried out within twenty-four months .

1. Consider providing additional low-level outlet facilities to decrease the drawdown time.

2. The owner should develop within one (1) year after formal approval of the report, written operating procedures and a periodic maintenance plan to insure the safety of the dam.

  
John P. Talerico, P.E.  
HARRIS-ECI ASSOCIATES



Photo taken on November 21, 1979

N.J. NO NAME DAM NO. 40

## PREFACE

This report is prepared under guidance contained in the Recommended Guidelines for Safety Inspection of Dams, for Phase I Investigations. Copies of these guidelines may be obtained from the office of the Chief of Engineers, Washington, D.C. 20314. The purpose of a Phase I Investigation is to identify expeditiously those dams which may pose hazards to human life or property. The assessment of the general condition of the dam is based upon available data and visual inspections. Detailed investigation, and analyses involving topographic mapping, subsurface investigations, testing, and detailed computational evaluations are beyond the scope of a Phase I investigation; however, the investigation intended to identify any need for such studies.

In reviewing this report, it should be realized that the reported condition of the dam is based on observations of field conditions at the time of inspection along with data available to the inspection team. It is important to note that the condition of a dam depends on numerous and constantly changing internal and external conditions, and is evolutionary in nature. It would be incorrect to assume that the present condition of the dam will continue to represent the condition of the dam at some point in the future. Only through continued care and inspection can there be any chance that unsafe conditions be detected.

Phase I inspections are not intended to provide detailed hydrologic and hydraulic analyses. In accordance with the established Guidelines, the Spillway Test flood is based on the estimated "Probable Maximum Flood" for the region (greatest reasonably possible storm runoff), or fractions thereof. The test flood provides a measure of relative spillway capacity and serves as an aide in determining the need for more detailed hydrologic and hydraulic studies, considering the size of the dam, its general condition and the downstream damage potential.

## TABLE OF CONTENTS

### ASSESSMENT OF GENERAL CONDITIONS

#### OVERVIEW PHOTO

#### PREFACE

#### Page

SECTION 1	PROJECT INFORMATION .....	1
	1.1 General .....	1
	1.2 Description of Project .....	1
	1.3 Pertinent Data .....	4
SECTION 2	ENGINEERING DATA.....	6
	2.1 Design .....	6
	2.2 Construction.....	6
	2.3 Operation .....	6
	2.4 Evaluation.....	6
SECTION 3	VISUAL INSPECTION.....	7
	3.1 Findings .....	7
SECTION 4	OPERATION PROCEDURES.....	9
	4.1 Procedures .....	9
	4.2 Maintenance of Dam.....	9
	4.3 Maintenance of Operating Facilities.....	9
	4.4 Evaluation .....	9
SECTION 5	HYDRAULIC/HYDROLOGIC .....	10
	5.1 Evaluation of Features.....	10
SECTION 6	STRUCTURAL STABILITY .....	12
	6.1 Evaluation of Structural Stability.....	12
SECTION 7	ASSESSMENT/REMEDIAL MEASURES .....	14
	7.1 Dam Assessment .....	14
	7.2 Remedial Measures .....	14

TABLE OF CONTENTS CONTINUED

	<u>No.</u>
KEY MAP AND VICINITY MAP.....	1 & 1A
GEOLOGIC MAP.....	2
DRAWINGS OF DAM.....	3

APPENDICES

APPENDIX A - CHECK LIST - VISUAL OBSERVATIONS CHECK LIST - ENGINEERING, CONSTRUCTION, MAINTENANCE DATA.....	1 - 14
APPENDIX B - PHOTOGRAPHS	
APPENDIX C - SUMMARY OF ENGINEERING DATA.....	1
APPENDIX D - HYDROLOGIC COMPUTATIONS.....	1 - 21

PHASE I INSPECTION REPORT  
NATIONAL DAM SAFETY PROGRAM

N.J. NO NAME DAM NO. 40, I.D. NJ 00208

SECTION 1

1. PROJECT INFORMATION

1.1 General

a. Authority

The National Dam Inspection Act (Public Law 92-367, 1972) provides for the National Inventory and Inspection Program by the U.S. Army Corps of Engineers. This inspection was made in accordance with this authority under Contract C-FPM No. 35 with the State of New Jersey who, in turn, is contracted to the Philadelphia District of the Corps of Engineers, and was carried out by the engineering firm of Harris-ECI Associates of Woodbridge, N.J.

b. Purpose of Inspection

The visual inspection of N.J. No Name Dam No. 40 was made on November 21, 1979. The purpose of the inspection was to make a general assessment as to the structural integrity and operational adequacy of the dam embankment and its appurtenant structures.

c. Scope of Report

The report summarizes available pertinent data relating to the project; presents a summary of visual observations made during the field inspection; presents an evaluation as to the structural adequacy of the various project features; and assesses the general condition of the dam with respect to safety.

1.2 Description of Project

a. Description of Dam and Appurtenances

N.J. No Name Dam No. 40 is an earth-fill dam approximately 190-foot long and 15-foot high. There is a concrete wall, 0.70-foot wide, on the upstream side of the dam. The spillway is located at the left end of the dam. It is a 48-inch diameter corrugated metal pipe approximately 40-foot long across the embankment. The former spillway is filled in with boulders and dirt. The top of the dam serves as a dirt road having a minimum width of approximately 21 feet. The downstream side slope of the embankment

varies with a maximum slope of 1:H to 1:V.

According to the owner, the low-level outlet consists of an 18-inch cast iron pipe through the dam located approximately 105 feet from the left end of the dam. The flow through the pipe is controlled by a manually operated gate valve located on top of the embankment. The inlet end of the pipe is located at the upstream toe of the slope. The outlet discharges through loose boulders on the slope of the downstream side of the embankment. No formal downstream channel exists, rather the discharge spreads over a wide area near the dam. The condition of the channel improves further downstream.

There are no known boring or test pit logs taken for this dam.

A generalized description of soil conditions is contained in Report No. 3, Passaic County, Engineering Soil Survey of New Jersey, by Rutgers University. The report, dated 1951, describes the lake area as a swamp. The surrounding deposit is glacial ground moraine. Glacial ground moraine is unstratified, heterogeneous material including clay, silt and sand sizes with varying amounts of gravel, cobbles and boulders. The depth to bedrock is variable but is generally shallow. Geologic Overlay Sheet 22 describes the bedrock around the lake as Hornblende Granite and Gneiss or Hypersthene-Quartz-Andesine Gneiss.

b. Location

N.J. No Name Dam No. 40 is located on a branch of Post Brook in the township of W. Milford, Passaic County. It is accessible by way of Algonquin Road.

c. Size Classification

According to the "Recommended Guidelines for Safety Inspection of Dams" by the U.S. Department of the Army, Office of the Chief Engineers, the dam is classified in the dam size category as being "small", since its storage volume of 226 acre-feet is less than 1,000 acre-feet. The dam is also classified as "small" because its height of 15 is less than 40 feet. The overall size classification of N.J. No Name Dam No. 40 is classified as "small" in size.

d. Hazard Classification

A hazard potential classification of "high" has been assigned to the dam on the basis that a hypothetical failure would result in excessive damage to the five houses, approximately 1000 feet downstream of the dam, and, therefore, the possibility exists of the loss of more than a few lives in the event of dam failure.

e. Ownership

N.J. No Name Dam No. 40 is owned by:

Mr. John Kalas  
220 Cartland Street  
Belleville, N.J. 07109

(201) 751-0136

f. Purpose

N.J. No Name Dam No. 40 is presently used for recreational purposes only.

g. Design and Construction History

No records are available on the design and construction history of N.J. No Name Dam No. 40.

h. Normal Operating Procedures

The discharge from the lake is unregulated and is allowed to naturally balance the inflow into the lake. The low level outlet is used to lower the lake level as required.

1.3 Pertinent Data

- a. Drainage Area 0.54 sq. mi.
- b. Discharge at Dam Site

Ungated spillway capacity at elevation of top of dam: 30 cfs (960.0 NGVD)

Total spillway capacity at maximum pool elevation (SDF): 1292 cfs (961.97 NGVD)

c. Elevation (Feet above NGVD)

Top of dam: 960  
Maximum pool design surcharge (SDF): 961.92  
Recreation pool: 957.6  
Spillway crest: 957.6  
Streambed at centerline of dam: 945.4 (estimated)  
Maximum tailwater: 948.0 (estimated)

d. Reservoir

Length of maximum pool: 2500 ft.(estimated)  
Length of recreation pool: 2400 ft.(estimated)

e. Storage (acre-feet)

Spillway Crest: 108  
Top of dam: 171  
Maximum pool (SDF): 226

f. Reservoir Surface (acres)

Top of dam: 27.5 (estimated)  
Maximum pool (SDF): 29.0 (estimated)  
Spillway crest: 25.7 (957.6 NGVD)

g. Dam

Type:	Earth fill with 48-inch diameter CMP culvert
Length:	190 ft. (effective)
Height:	15 ft.
Top width:	21 ft.
Side slopes - Upstream:	1H:1V
- Downstream:	1H:1V, Max. & Variable
Zoning:	Unknown
Impervious core:	Unknown
Cutoff:	Unknown
Grout curtain:	None

h. Diversion and Regulating Tunnel

N/A

i. Spillway

Type:	48-inch CMP culvert
Invert Elevation:	957.6
Gates:	None
U/S Channel:	Dirt ditch approximately 5 ft. wide and 5 ft. deep
D/S Channel:	No specific channel at D/S of dam. The water discharges into a wide valley and flows into the natural channel about a few hundred feet downstream of the dam.

j. Regulating Outlets

Low level outlet:	According to owner, 18 inch C.I.P.
Controls:	Manually controlled gate valve
Emergency gate:	None
Outlet:	949.4 NGVD

## SECTION 2

### 2. ENGINEERING DATA

#### 2.1 Design

No plans for the original construction of N.J. No Name Dam No. 40 are available at the Trenton Offices of the N.J. Department of Environmental Protection (N.J.-DEP). No embankment data from soil borings, soil tests, design computations, or other geotechnical data are available to assess the embankment stability properly. No data concerning the hydraulic capacity of the spillway is available.

#### 2.2 Construction

Data is not available concerning the as-built construction of the dam. No data exists of construction methods, borrow sources, or other data pertinent to the construction of the dam.

#### 2.3 Operation

Formal operation records are not kept for the dam and reservoir. The lake is allowed to operate naturally without regulation.

#### 2.4 Evaluation

##### a. Availability

The availability of engineering data is very poor. No plans, computations, or correspondences concerning the original construction of the dam are available from the NJ-DEP.

##### b. Adequacy

The engineering data obtained in the field was adequate to perform hydrologic and hydraulic computations. The data was insufficient to perform a stability analysis, but preliminary evaluation could be made based on visual observations.

##### c. Validity

Since no existing engineering data exists, the validity of that data could not be compared to the data obtained in the field.

## SECTION 3

### 3. VISUAL INSPECTION

#### 3.1 Findings

##### a. General

The visual inspection of N.J. No Name Dam No. 40 revealed the dam to be in poor condition. The main safety concern is related to the significant seepage on the downstream side of the embankment slope.

##### b. Dam

The earth embankment appears sound. The top of the embankment is not paved but serves as a roadway. No vehicles traveled the roadway during the time of inspection. There is a concrete wall along the embankment on the upstream side. Cracking and spalling of this wall were noticed in the vicinity left of the former spillway. Erosion was observed on the downstream side of the embankment opposite the former spillway. Vertical and horizontal alignment of the crest at the embankment could not be checked because the underlying "original" embankment has been covered over with rocks and dirt to form the dirt road. Small to medium sized birch trees were observed growing on the embankment. Seepage was significant on the down stream side of the embankment. The location of the seepage was at about the center of the dam just above the toe and was running clear. No evidence of burrowing by animals was discovered.

##### c. Appurtenant Structures

###### 1. Spillways

According to the owner, the former spillway was concrete. It is now filled and covered by the existing roadway. A break in the concrete wall along the embankment, on the upstream side, is the location of the former spillway. A 48-inch corrugated metal pipe is now the present spillway. The C.M.P., in good condition, is at the left end of the dam and is approximately 40-foot long. Cover (the dirt road) over the C.M.P. is less than 12 inches. The spillway's approach and discharge channels are dirt ditches, approximately 5-foot deep x 5-foot wide.

###### 2. Outlet Works

According to the owner, an 18-inch cast iron pipe serves as the low level outlet drain. Loose boulders covered the drain so the verification of the size and type of the drain could not be made. However, discharge from this low level outlet drain was observed downstream on the side of the embankment rather than its toe. The low level control valve was housed in a concrete chamber located on the embankment left of the former spillway. The chamber has no cover.

d. Reservoir Area

The side slopes of the reservoir are flat to moderate. There was no indication of slope instability. The reservoir water was clear with no growth of algae.

e. Downstream Channel

No formal downstream channel exists in the vicinity of the embankment. The discharge spreads over a wide area. Numerous uprooted trees lay in the channel. The condition of the channel improves further downstream. Five houses are located approximately 1000 feet from the dam.

## SECTION 4

### 4. OPERATIONAL PROCEDURES

#### 4.1 Procedures

N.J. No Name Dam No. 40 is used to impound water for recreational activities. The level of the lake is maintained through the unregulated flow over the spillway.

#### 4.2 Maintenance of the Dam

There is no regular inspection and maintenance program for the dam and appurtenant structures. Mr. John Kalas is responsible for the maintenance of the dam.

#### 4.3 Maintenance of Operating Facilities

The low-level outlet operating facilities consist of the one manually operated 18-inch gate valve. Operation of the valve was satisfactorily demonstrated.

#### 4.4 Evaluation

The present operational and maintenance procedures are fair with the dam and spillway being maintained in a serviceable condition.

## SECTION 5

### 5. HYDRAULIC/HYDROLOGIC

#### 5.1 Evaluation of Features

##### a. Design

The drainage area above N.J. No Name Dam No. 40 is approximately 0.54 square miles. A drainage map of the water shed of the dam site is presented on Plate 1, Appendix D.

The topography within the basin is generally moderately sloped. Elevations range from approximately 1190 feet above MSL at the Northwest end of the watershed to about 968 feet at the dam site. Land use patterns within the watershed are mostly woodland and swamp with some residential development around the lake area.

The evaluation of the hydraulic and hydrologic features of the dam was based on criteria set forth in the Corps guidelines and additional guidance provided by the Philadelphia District, Corps of Engineers. The SDF for the Dam falls in a range of 1/2 PMF to PMF. In this case, the low end of the range, 1/2 PMF, is chosen since the factors used to select size and hazard classification are on the low-side of their respective ranges.

The probable Maximum Flood (PMF) was calculated from the probable maximum precipitation using Hydrometeorological Report No. 33 with standard reduction factors. Due to the small drainage area, the SCS triangular hydrograph transformed to a curvilinear hydrograph was adopted for developing the unit hydrograph, with the aid of the HEC-1-DB Flood Hydrograph Computer Program.

Initial and constant infiltration loss rates were applied to the Probable Maximum Precipitation to obtain rainfall excesses. The rainfall excesses were applied to the unit hydrograph to obtain the PMF and various ratios of PMF utilizing program HEC-1-DB.

The SDF peak outflow calculated for the dam is 1,292 cfs. This value is derived from the half PMF, and results in overtopping of the dam, assuming that the lake was originally at the spillway crest elevation.

The stage-outflow relation for the spillway was determined from the geometry of the spillway and dam, utilizing HEC-1-DB program.

The reservoir stage-storage capacity relationship was computed directly by the conic method, utilizing the HEC-1-DB program. The reservoir surface areas at various elevations were measured by planimeter from a U.S.G.S. Quadrangle topographic map. Reservoir storage capacity included surcharge levels exceeding the top of the dam, and the spillway rating

curve was based on the assumption that the dam remains intact during routing. The spillway rating curve is presented in the Hydrologic Computation, Appendix D.

A breach analysis indicates that the stage of the stream where it crosses Crescent Road is 5.4 feet higher, due to dam failure from overtopping at 0.2 PMF than it would be without failure at 0.2 PMF. This is likely to jeopardize the well traveled road downstream significantly more than without failure. The discharge facility is thus rated "seriously inadequate".

Drawdown calculations indicate that to empty the lake to an elevation of 951.8 NGVD through the one low-level outlet would take 10 days, assuming a 2 cfs/square mile inflow. This is considered to be an excessive draw-down period, and provision of additional outlets should be considered.

b. Experience Data

No records of reservoir stage or spillway discharge are maintained for this site.

c. Visual Observation

No defined discharge channel exists immediately downstream of the embankment and the water flows over a wide area. Numerous uprooted trees lay within this area. The condition of the channel improves further downstream. The slopes of the channel are flat and trees are growing on them. Five houses are located approximately 1200 feet from the dam.

The side slopes of the reservoir are flat to moderate and do not exhibit signs of instability. The drainage area is wooded and moderately flat sloped.

d. Overtopping Potential

A storm of magnitude equivalent to the SDF would cause overtopping of the dam to a height of 1.97 feet. Computations indicate that the dam can pass approximately 11 percent of the PMF without overtopping the dam crest. Since the 1/2 PMF is the Spillway Design Flood (SDF) for this dam, according to the Recommended Guidelines for Safety Inspection of Dams by the Corps of Engineers, the spillway capacity of the dam is assessed as "seriously inadequate".

## S E C T I O N 6

### 6. STRUCTURAL STABILITY

#### 6.1 Evaluation of Structural Stability

##### a. Visual Observations

The earth embankment appears sound. The misalignment of the roadway which is the present crest appears due to the method of construction rather than settlement or movement. The trees that are growing on the embankment could pose a threat to stability. Seepage was observed above the toe at the downstream slope near the center of the dam. It was significant but was running clear. No evidence of burrowing by animals was discovered.

##### b. Design and Construction Data

No design computations relating to stability were uncovered during the report preparation phase. No embankment or foundation soil parameters are available for carrying out a conventional stability analysis on the embankment.

##### c. Operating Records

No operating records are available relating to the stability of the dam.

##### d. Post-Construction Changes

A roadway was constructed on the original crest and spillway of the dam. Also a 48-inch C.M.P. was placed through the embankment to serve as the new spillway.

##### e. Static Stability

A static stability analysis was not performed for N.J. No Name Dam No. 40 because the lack of data on which to base assumptions of material properties within the embankment zones might produce misleading results. The recommended remedial actions must be implemented in order to decrease the risk of local failure, but based on the findings of the visual inspection, the preliminary assessment of static stability is that it is satisfactory.

##### f. Seismic Stability

N.J. No Name Dam No. 40 is located in Seismic Zone 1, as defined in Recommended Guidelines for Safety Inspection of Dams, prepared by the Corps of Engineers. In general, projects located in Seismic Zones 0, 1 and 2 may be assumed to present no hazard from earthquake, provided the static stability condition are satisfactory and conventional safety margins

exist and based on the findings of the visual inspection, the preliminary assessment of the static and seismic stabilities is that they are satisfactory.

## SECTION 7

### 7. ASSESSMENT/REMEDIAL MEASURES

#### 7.1 Dam Assessment

##### a. Safety

The dam has been inspected visually and a review has been made of the available engineering data. This assessment is subject to the limitations inherent in the visual inspection procedures stipulated by the Corps of Engineers for a Phase I report.

The safety of N.J. No Name Dam No. 40 is in question because the dam does not have adequate spillway capacity to pass the SDF, one half of the PMF, without overtopping. Overtopping of the dam carries with it the danger of a likely progressive failure of the dam. The present spillway capacity of the dam is approximately 11 percent of the PMF.

No definitive statement pertaining to the safety of the embankment can be made without acquisition of embankment material engineering properties and determination of phreatic levels in the downstream part of the embankment, but based on the findings of the visual inspection, preliminary assessment of the static stability is that it is satisfactory.

##### b. Adequacy of Information

The information uncovered was adequate to perform hydrologic and hydraulic computations. The data was insufficient to perform even an approximate computation of the stability of the dam. A preliminary assessment of the dam could be made by visual observation only.

##### c. Urgency

The remedial measures and recommended actions along with a timetable for their completion are detailed below. All recommended action should be conducted under the supervision of an engineer who is experienced in the design, construction and inspection of dams.

#### 7.2 Remedial Measures

##### a. Alternatives for Increasing Spillway Capacity

Alternatives for increasing spillway capacity are as follows:

1. Increase the embankment height of the dam thus permitting a higher discharge to pass

over the spillway and reducing the possibility of overtopping.

2. Lower the spillway crest elevation.
3. Increase the effective spillway crest length.
4. A combination of any of the above alternatives.

b. Recommendations

1. Carry out a more precise hydrologic and hydraulic analysis of the dam within twelve months, to determine the need and type of mitigating measures necessary. If required, conduct a study of the means of increasing spillway discharge capacity and develop alternative schemes for construction. This should include the installation of headwater and tailwater gages. The ability of the dam to withstand overtopping should also be studied.
2. Observation wells or piezometers should be installed in the embankment to determine the location of the phreatic surface and the paths of the seepage observed. This should be done within six months.
3. The flow of the seepage should be monitored monthly to determine its volume and whether it presents a problem to the safety of the dam.
4. Conduct a complete topographic survey of the dam and surrounding area in order to develop a detail plan and cross-section of the dam to form a coherent as-built set within twenty-four months.
5. Repair all cracked and spalled concrete within twelve months.
6. All brush and trees should be removed from the downstream and upstream slopes to avoid problems which may develop from roots. The embankment face should then be seeded to develop a growth of grass for surface erosion protection. This program should be started within twelve months.
7. Provide a headwall and side slope and channel bottom protection for both the approach and discharge channels. Extend the protection for the discharge channel to beyond the embankment toe of slope. This should be completed within twelve months providing the pipe is not

required to be replaced as a result of the hydrologic and hydraulic analysis of the dam. (See Item 1 above).

8. Construct channels to carry the discharge from the spillway and the low-level outlet to the existing downstream channel within twelve months.
9. Remove the boulders from the discharge end of the low-level outlet, and provide a headwall and apron and a cover for the valve chamber within twelve months.

The following additional actions are recommended:

1. The owner should develop an emergency action plan (if one is not already available) outlining actions to be taken by the operator to minimize downstream effects of an emergency and establish a flood warning system for the downstream communities within three months.
2. Consider providing additional low-level outlet facilities to decrease drawdown time.

c. O & M Procedures

The owner should develop, within one (1) year after formal approval of the report, written operating procedures and a periodic maintenance plan to insure the safety of the dam.

P L A T E S

N. J. NO NAME  
DAM NO. 40

WEST MILFORD TWP.  
PASSAIC COUNTY, N. J.

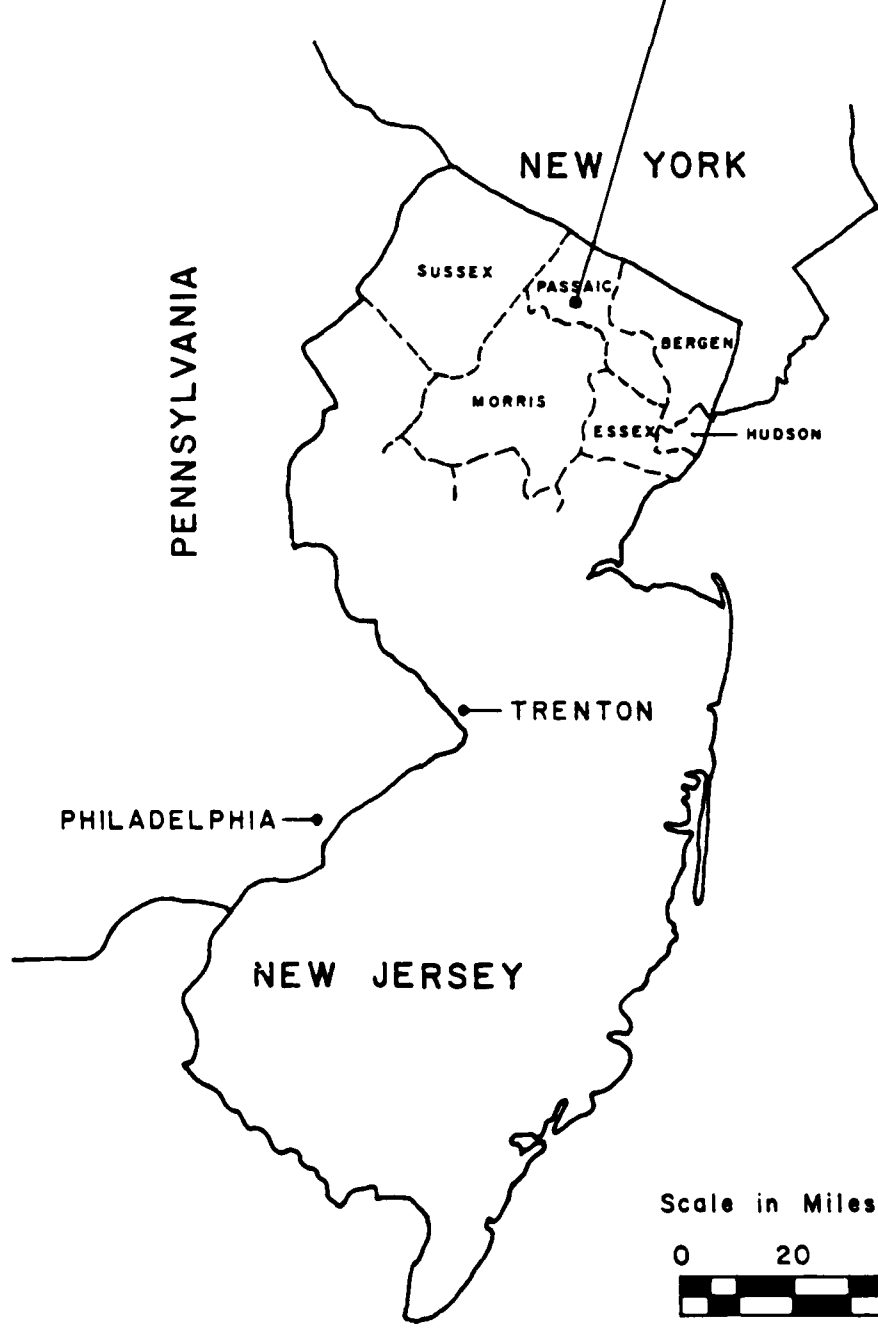

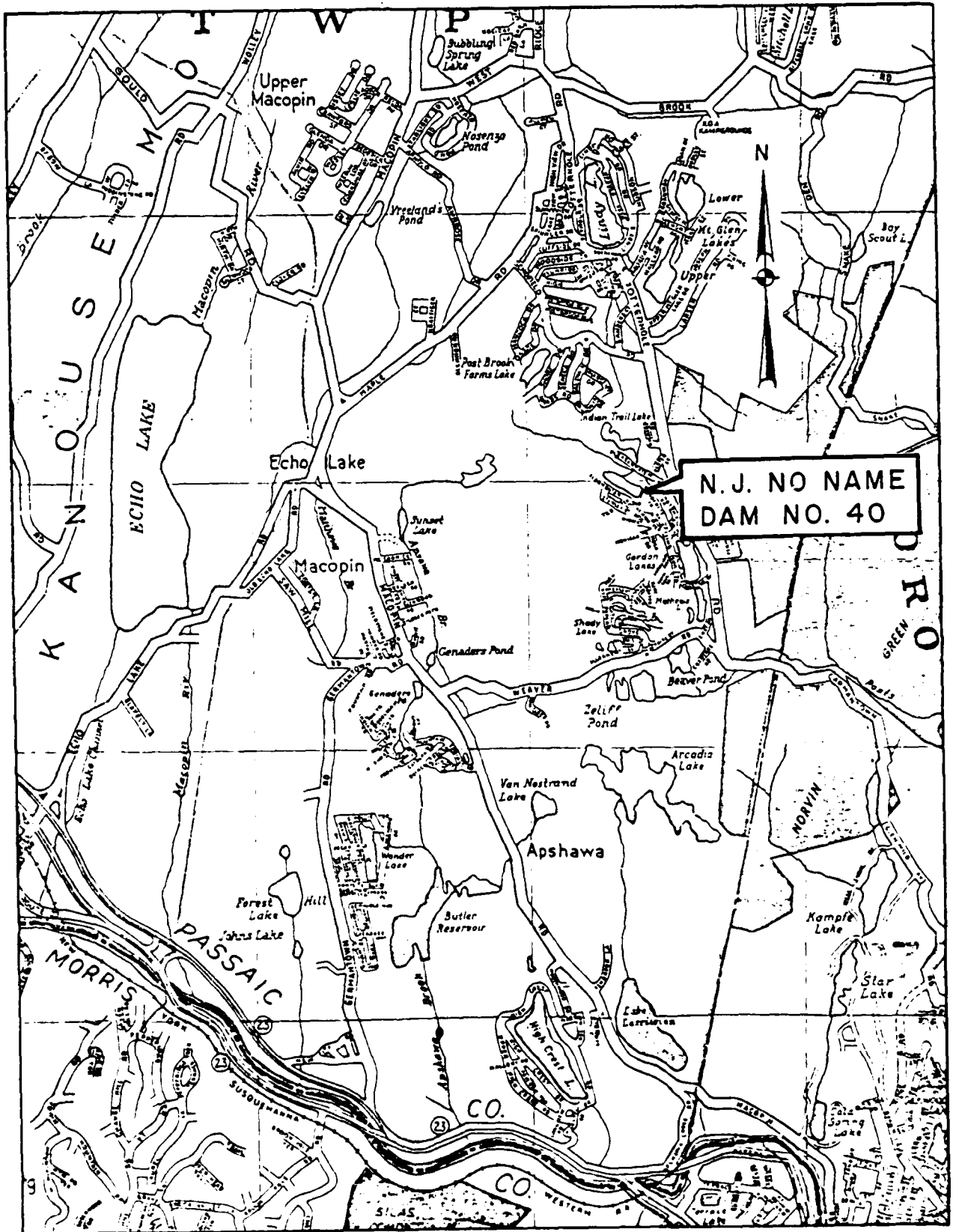

N.J. NO NAME  
DAM NO. 40

Scale in Feet (Approx.)

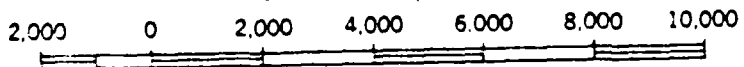

VICINITY MAP

PLATE IA

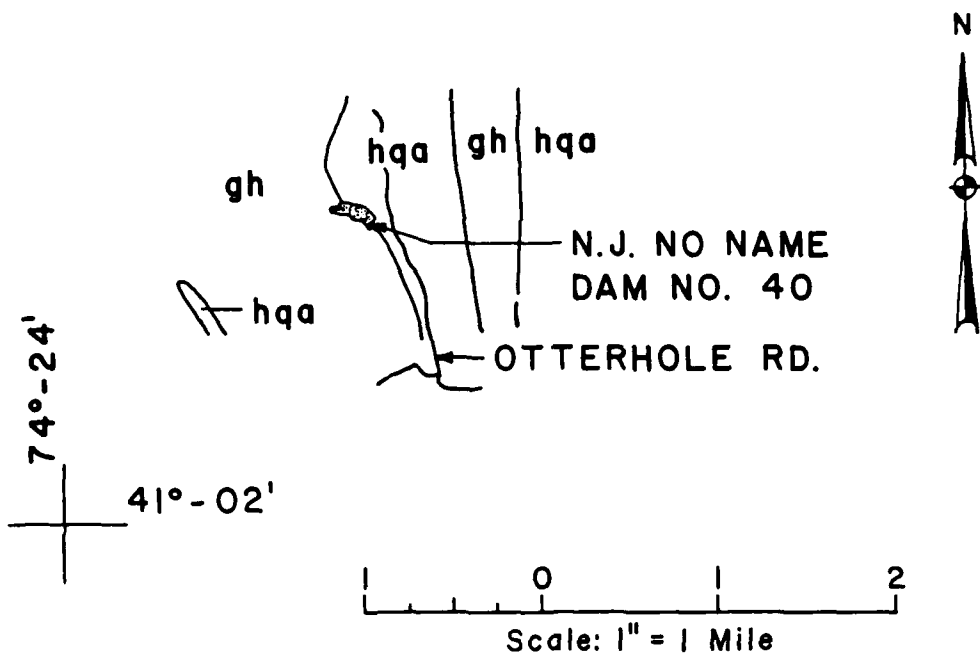

LEGEND:

PRECAMBRIAN

gh Mostly Hornblende Granite and Gneiss.

hqa Hyperstene-Quartz-Andesine Gneiss.

     Fault

GEOLOGIC MAP  
N. J. NO NAME DAM NO. 40

L A

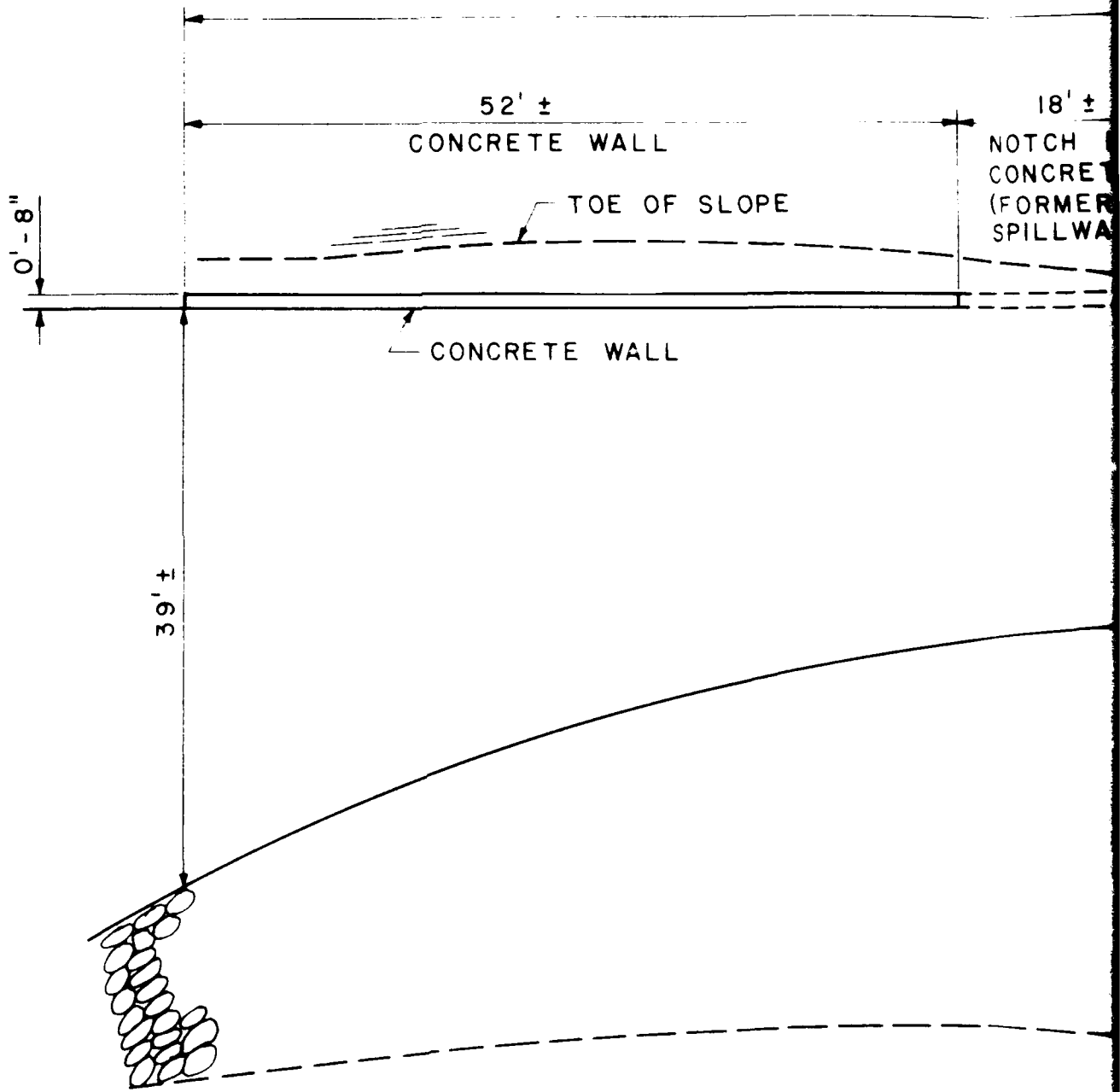

1

A K E

186' ±  
EMBANKMENT

18' ±  
NOTCH IN  
CONCRETE  
(FORMER  
SPILLWAY)

116' ±  
CONCRETE WALL



CONCRETE CHAMBER  
HOUSING FOR LOW  
LEVEL CONTROL  
VALVE

CONCRETE WALL

DIRT ROAD

2' ±

18" C.I.P.

8' ±

TOP OF EMBANKMENT

LOOSE BOULDERS

TOE OF SLOPE



PLAN

2

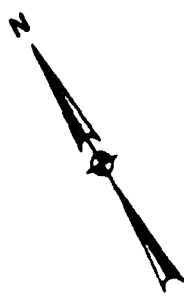

4'-0"  
SPILLWAY



0'-8"

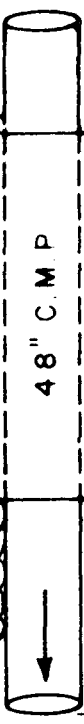

21' ±

40' ±

EMENT

3

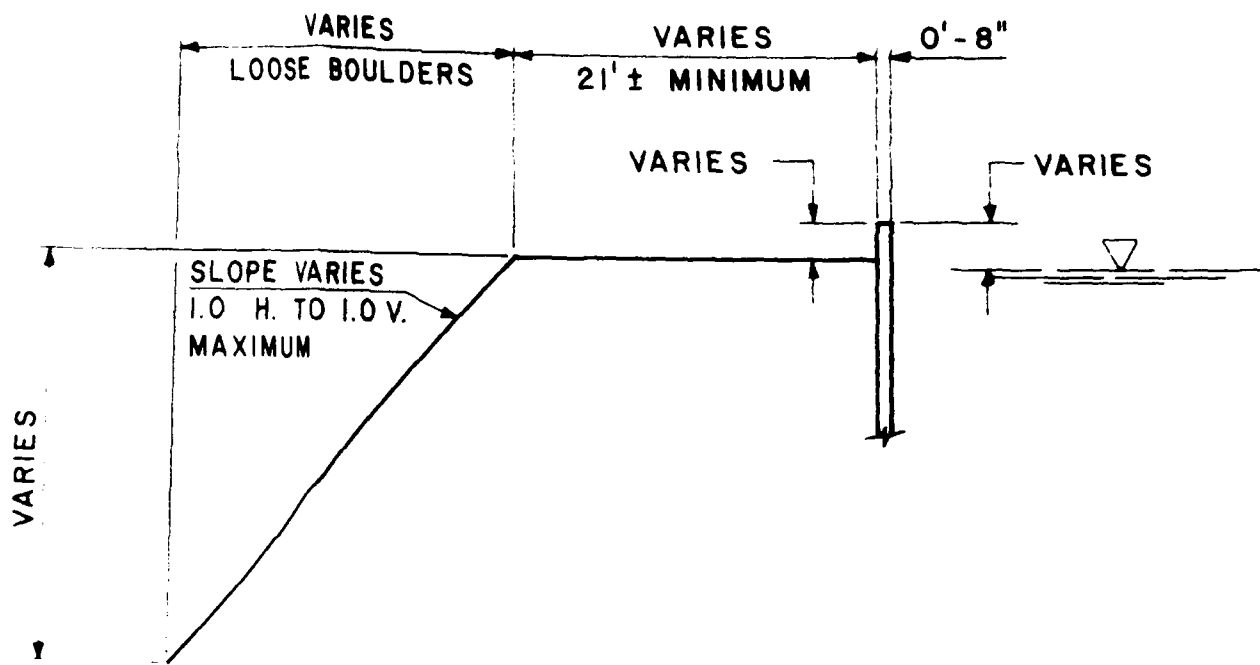

SECTION A-A

N. J. NO NAME DAM NO. 40  
 WEST MILFORD TWP., PASSAIC COUNTY, N. J.

SKETCHES OF PLAN AND SECTION  
 PREPARED FROM FIELD NOTES TAKEN  
 DURING INSPECTION ON NOV. 21, 1979

BY:  
 HARRIS - ECI ASSOCIATES  
 WOODBRIDGE, NEW JERSEY

SCALE: 1" = 10 FEET  
 DATE: JAN. 31, 1980  
 SHEET: 1 OF 1

APPENDIX A  
CHECK LIST - VISUAL OBSERVATIONS  
CHECK LIST - ENGINEERING, CONSTRUCTION  
MAINTENANCE DATA

CHECK LIST  
VISUAL INSPECTION  
PHASE 1

Name Dam NEW JERSEY NO NAME DAM NO. 40 County Passaic State New Jersey Coordinators NJ-DEP

Date(s) Inspection November 21, 1979 Weather Sunny Temperature 40°F

Pool Elevation at Time of Inspection 957.6 NGVD \*Tailwater at Time of Inspection 945.7 NGVD

Inspection Personnel:

November 21, 1979:

Chuck Chin  
Eugene Koo (Recorder)  
Thomas Lakovich

Owner/Representative:

Mr. John Kalas  
220 Cartland Street  
Belleville, NJ 07109

\* At the toe of slope.

VISUAL EXAMINATION OF	CONCRETE/MASONRY DAMS OBSERVATIONS	REMARKS AND RECOMMENDATIONS
SEEPAGE OR LEAKAGE N/A		
STRUCTURE TO ABUTMENT/EMBANKMENT JUNCTIONS N/A		
DRAINS N/A		
WATER PASSAGES N/A		
FOUNDATIONS N/A		

CONCRETE/MASONRY DAMS

VISUAL EXAMINATION OF

OBSERVATIONS

REMARKS AND RECOMMENDATIONS

SURFACE CRACKS CONCRETE SURFACES  
N/A

STRUCTURAL CRACKING  
N/A

VERTICAL & HORIZONTAL ALIGNMENT  
N/A

MONOLITH JOINTS  
N/A

CONSTRUCTION JOINTS  
N/A

VISUAL EXAMINATION OF	EMBANKMENT OBSERVATIONS	REMARKS AND RECOMMENDATIONS
SURFACE CRACKS None noticed.		
UNUSUAL MOVEMENT OR CRACKING AT OR BEYOND THE TOE Cracking and spalling of the concrete wall were observed. The wall is on the upstream side of embankment and the cracking and spalling is just left of the former spillway.		Repair cracking and spalling.
SLOUGHING OR EROSION OF EMBANKMENT AND ABUTMENT SLOPES Erosion was observed on the downstream side of the embankment opposite the former spillway.		Refill eroded area.
VERTICAL & HORIZONTAL ALIGNMENT OF THE CREST Crest of the existing embankment has been covered over with rocks and dirt to form the dirt road. Therefore, the vertical and horizontal alignment of the original embankment could not be ascertained, but the alignment of the road is uneven.		
RIPRAP FAILURES N/A		

VISUAL EXAMINATION OF	EMBANKMENT OBSERVATIONS	REMARKS AND RECOMMENDATIONS
EARTH EMBANKMENT	Top of embankment is not paved but used as a roadway. No vehicles traveled it during time of inspection. Small to medium sized birch trees are growing on both sides of the embankment. Some of the trees are uprooted. Loose boulders are scattered along the embankment with majority of the boulders being on the downstream side of the embankment.	Remove trees.
JUNCTION OF EMBANKMENT AND ABUTMENT, SPILLWAY AND DAM	N/A. See "DRAINS" below.	
ANY NOTICEABLE SEEPAGE	Seepage was significant on the downstream side of the embankment. Location of seepage was at about center of dam just above the toe. Seepage was clear.	Collect, monitor and measure seepage. Determine origin, if possible.
STAFF GAGE AND RECORDER	None	
DRAINS	A 48-inch diameter corrugated metal pipe, in good condition, is at the left side of the dam. It takes the place of the former spillway. Cover over the pipe is less than 12 inches.	

OUTLET WORKS  
OBSERVATIONS

VISUAL EXAMINATION OF

REMARKS AND RECOMMENDATIONS

CRACKING & SPALLING OF CONCRETE SURFACES IN STILLING BASIN

Loose boulders and dirt covered the stilling basin of the low-level outlet drain. The low-level outlet drain discharges downstream on the side of the embankment rather than at its toe.

INTAKE STRUCTURE

Low level outlet drain under water in lake. Not visible.

OUTLET STRUCTURE

According to the owner, an 18-inch cast iron pipe is the low-level outlet drain. Loose boulders covered the drain and therefore verification of the size and the type of drain could not be made. However, discharge from the pipe was observed on the downstream side of the embankment. The control valve for the low-level outlet drain was housed in a concrete chamber. The chamber, located on the embankment left of the former spillway, has no cover. Control valve operated satisfactorily. A 12-inch diameter rubber pipe, used to siphon water out of the lake, was not operating.

Remove boulders from discharge end of pipe and provide a head-wall and apron for embankment protection. Provide a cover for the outlet valve chamber.

OUTLET FACILITIES

None

EMERGENCY GATE

None

UNGATED SPILLWAY

REMARKS AND RECOMMENDATIONS

OBSERVATIONS

VISUAL EXAMINATION OF

**CONCRETE WEIR**

According to the owner, a concrete spillway did exist. The spillway has been filled and covered over with dirt and rock and is now part of the dirt road. The 48-inch C.M.P., described under "EMBANKMENT", serves as the present spillway.

**APPROACH CHANNEL**

An unlined ditch, about 5 feet deep by 5 feet wide, forms the approach channel to the 48-inch C.M.P.

Provide headwall, side slope and channel bottom protection.

**DISCHARGE CHANNEL**

The discharge channel from the 48-inch C.M.P. is also an unlined ditch approximately 5 feet deep by 5 feet wide.

Provide a headwall, side slope and channel bottom protection. Carry protection to beyond embankment toe of slope.

**BRIDGE AND PIERS**

None

GATED SPILLWAY

REMARKS AND RECOMMENDATIONS

OBSERVATIONS

VISUAL EXAMINATION OF

CONCRETE SILL  
N/A

APPROACH CHANNEL  
N/A

DISCHARGE CHANNEL  
N/A

BRIDGE AND PIERS  
N/A

GATES & OPERATION EQUIPMENT  
N/A

VISUAL EXAMINATION OF	INSTRUMENTATION OBSERVATIONS	REMARKS AND RECOMMENDATIONS
MONUMENTATION/SURVEYS None		
OBSERVATION WELLS None		
WEIRS None		
PIEZOMETERS None		
OTHER None		

RESERVOIR OBSERVATIONS	REMARKS AND RECOMMENDATIONS
VISUAL EXAMINATION OF SLOPES Side slopes are flat to moderate. No indication of slope instability.	
SEDIMENTATION None noticed.	

DOWNSTREAM CHANNEL  
OBSERVATIONS

REMARKS AND RECOMMENDATIONS

CONDITION (OBSTRUCTIONS, DEBRIS, ETC.)

There is no formal downstream channel for 200 - 300 feet from the embankment. The discharge flows into a relatively wide area just below the downstream side of the embankment. Numerous uprooted trees lay within this wide discharge area.

SLOPES

Flat. Covered with trees.

APPROXIMATE NUMBER OF HOMES AND POPULATION

Five houses are located approximately 1,000 feet from the dam.

CHECK LIST  
ENGINEERING DATA  
DESIGN, CONSTRUCTION, OPERATION

ITEM	REMARKS
PLAN OF DAM	None available.
REGIONAL VICINITY MAP	Available - Passaic County Map and U.S.G.S. Quadrangle Sheet for Wanaque, N.J.
CONSTRUCTION HISTORY	According to the owner, the former spillway had flashboards.
TYPICAL SECTIONS OF DAM	Not available.
HYDROLOGIC/HYDRAULIC DATA	Not available.
OUTLETS - PLAN	Not available.
- DETAILS	Not available.
- CONSTRAINTS	None
- DISCHARGE RATINGS	Not available.
RAINFALL / RESERVOIR RECORDS	Not available.

CHECK LIST  
ENGINEERING DATA  
DESIGN, CONSTRUCTION, OPERATION  
(continued)

ITEM	REMARKS
DESIGN REPORTS	None available.
GEOLOGY REPORTS	Available U.S.G.S. Geologic overlay sheet for Passaic County and Engineering Soils Survey of New Jersey, Report No. 3 - Passaic County, by Rutgers University.
DESIGN COMPUTATIONS HYDROLOGY & HYDRAULICS DAM STABILITY SEEPAGE STUDIES	None available.
MATERIALS INVESTIGATIONS BORING RECORDS LABORATORY FIELD	None available.
POST-CONSTRUCTION SURVEYS OF DAM	None
BORROW SOURCES	Unknown
SPILLWAY PLAN - SECTIONS - DETAILS	Not available.

CHECK LIST  
ENGINEERING DATA  
DESIGN, CONSTRUCTION, OPERATION  
(continued)

ITEM	REMARKS
OPERATING EQUIPMENT PLANS AND DETAILS	None available.
MONITORING SYSTEMS	None available.
MODIFICATIONS	Unknown.
HIGH POOL RECORDS	Not kept.
POST CONSTRUCTION ENGINEERING STUDIES AND REPORTS	None available.
PRIOR ACCIDENTS OF FAILURE OF DAM - DESCRIPTION - REPORTS	None known to exist.
MAINTENANCE OPERATION RECORDS	None known to exist.

APPENDIX B

PHOTOGRAPHS

(Photos taken on November 21, 1979)



Photo 1 - View of embankment toward spillway (not visible - is 48-inch C.M.P. across embankment). Concrete chamber housing the low-level control valve is at lower left. Note trees growing on embankment.



Photo 2 - View toward lake. In foreground is concrete chamber housing the low-level control valve mentioned in Photo 1. Abandoned siphon, from lake to chamber, is at left. Notch in concrete wall is location of former spillway.



Photo 3 - Detail of concrete wall, shown in Photo 2, depicting cracking and spalling.



Photo 4 - View of downstream channel. Discharge from low-level outlet drain, covered by boulders, is shown at bottom center. All visible piping is dumped refuse.



Photo 5 - View of downstream side of the embankment looking toward the low-level outlet drain. Discharge from the drain is visible at left center. Note loose boulders and trees growing on the embankment.

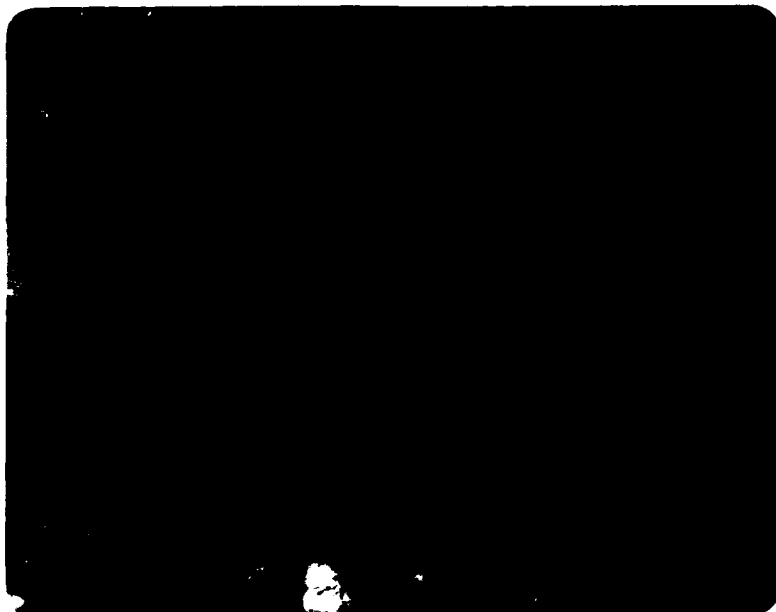

Photo 6 - View of lake from embankment.



Photo 7 - View of spillway from the lake. The spillway, a 48-inch corrugated metal pipe, crosses under the embankment at its left side.



Photo 8 - View of the lake from embankment. Portion of spillway, the 48-inch corrugated metal pipe, is shown at bottom.



Photo 9 - View of downstream channel just beyond the spillway (48-inch C.M.P.), a portion of which is shown at bottom right.

APPENDIX C  
SUMMARY OF ENGINEERING DATA

CHECK LIST  
HYDROLOGIC AND HYDRAULIC DATA  
ENGINEERING DATA

Name of Dam: NJ NO NAME DAM NO. 40

Drainage Area Characteristics: 0.54 square miles

Elevation Top Normal Pool (Storage Capacity): 957.6 NGVD (108 acre-feet)

Elevation Top Flood Control Pool (Storage Capacity): N/A

Elevation Maximum Design Pool: 961.97 NGVD (SDF pool: 226 acre-feet)

Elevation Top Dam: 960.0 NGVD (171 acre-feet)

SPILLWAY CREST:

a. Elevation 957.6 NGVD

b. Type 48-inch diameter C.M.P. Culvert

c. Width -

d. Length 40 feet

e. Location Spillover Left of the dam.

f. No. and Type of Gates None

OUTLET WORKS:

a. Type 18-inch C.I.P. (According to owner)

b. Location Right center of the dam.

c. Entrance Inverts 951 NGVD (estimated)

d. Exit Inverts 949.4 NGVD

e. Emergency Draindown Facilities 18-inch Valve, 18-inch dia. CIP  
(According to owner)

HYDROMETEOROLOGICAL GAGES:

a. Type None

b. Location None

c. Records None

MAXIMUM NON-DAMAGING DISCHARGE: 30 cfs at elevation 960.0 NGVD

APPENDIX D  
HYDROLOGIC COMPUTATIONS

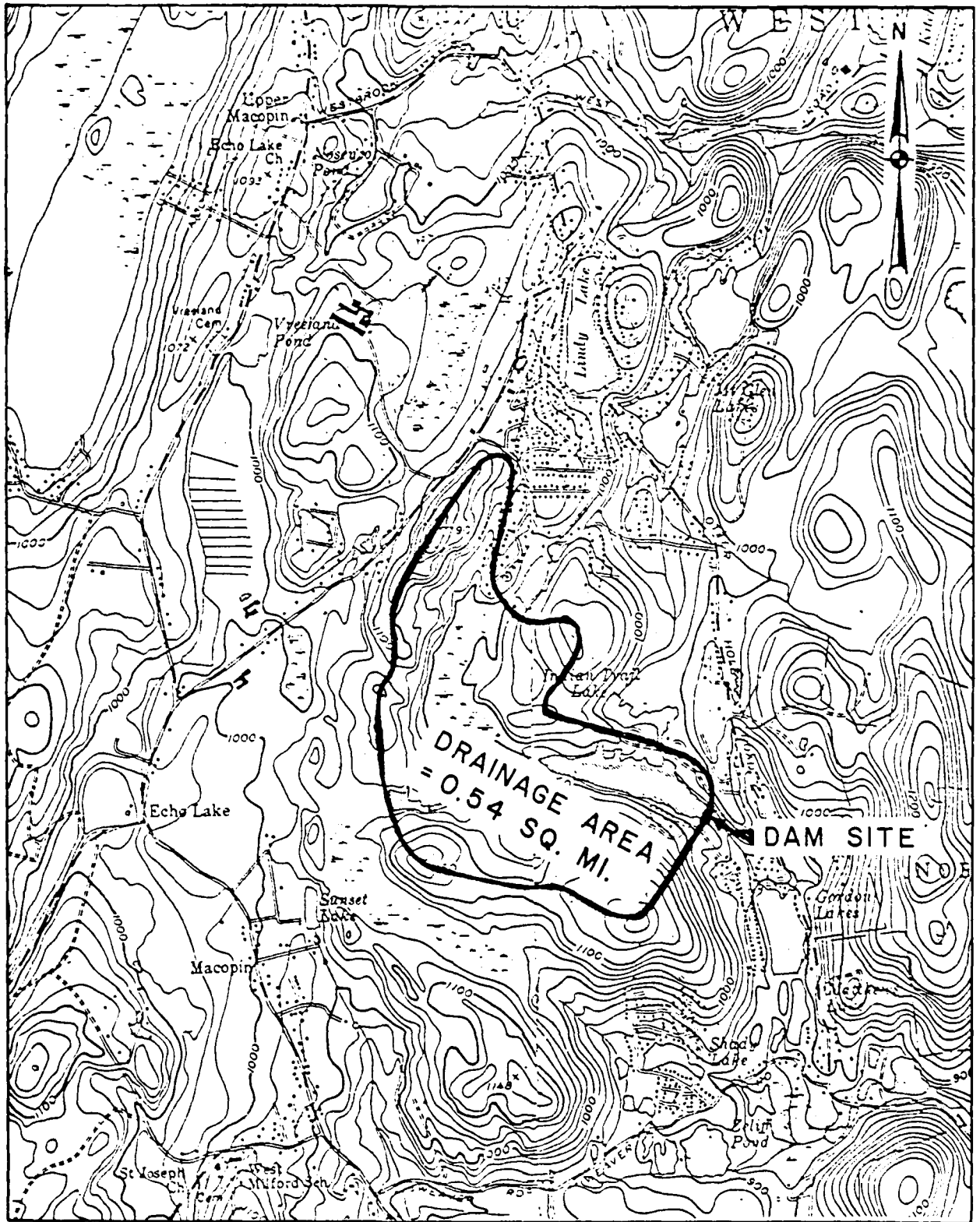

2,000 0 2,000 4,000

Scale: 1" = 2,000 FT.

N. J. NO NAME DAM NO. 40  
DRAINAGE BASIN

FREDERIC R. HARRIS, INC.  
CONSULTING ENGINEERS

SUBJECT N.J. DAM SAFETY INSPECTION  
N.J. NO NAME 40 DAM  
COMPUTED BY C.L.C. CHECKED BY PK

SHEET NO. 1 OF 11  
JOB NO. 10-ASB-01  
DATE 1-24-80

Group XVII

N.J. NO NAME 40 DAM (N.J. 00208)

### SIZE CLASSIFICATION

Main Impoundment Surface Area	25.7 Acres
Average Depth of Lake	
Structural Height of Dam	15 ft
Size Classification	Small

### HAZARD POTENTIAL CLASSIFICATION

Houses - nearing channel at about 1200' D/S of Dam	
Hazard Potential	High
Recommended SDF	$\frac{1}{2}$ PMF

### HYDROLOGIC ANALYSIS

Flood routing will be computed by HEC-1 DB computer program using SCS Triangular unit Hydrograph with curvilinear transformation.

D.A. = 0.54 sq. mi.

FREDERIC R. HARRIS, INC.  
CONSULTING ENGINEERS

SUBJECT N.J. DAM SAFETY INSPECTION  
N.J. NO NAME 40 DAM  
COMPUTED BY C.L.C. CHECKED BY [Signature]

SHEET NO. 2 OF 11  
JOB NO. 10-AB3-01  
DATE 1-24-80

PRECIPITATION

From fig. 15 ( Ref.: 'Design of Small Dam', p. 48 ), the drainage basin is located at Zone 1 & Zone 6 where the probable max. precipitation = 25" based on 6 hrs. duration and a 10 sq. mi basin.

DURATION (HRS.)

% OF PMF

	<u>ZONE 1</u>	<u>ZONE 6</u>	<u>AVG.</u>
6	99	100	100
12	111	109	110
24	119	117	118
48	127	126	127

Note: Values are reduced by 20% to account for misalignment of basin & storm isohyets.

INFILTRATION DATA

Drainage Area consists mostly of MMg & GMAXZAR  
MMg

Hydrologic Soil Group

D

Initial Infiltration

1.0 inch

Constant Infiltration

0.1 inch/hr

Ref.: 'Engineering Soil Survey of N.J. Report 3, Passaic County.'  
by Rutgers University, July, 1951.

TIME OF CONCENTRATION

1) From velocity & water course length:

	<u>Slope (o/o)</u>	<u>Vel. (fps)</u>	<u>Remark</u>
Overland Flow	$\frac{1190-1000}{1400} = 13.6$	3.5	Upper watershed Woodland
Overland flow	$\frac{1000-982}{1800} = 1.0$	1	Thin Swamp area
reach 1	$\frac{982-957}{750} = 3.6$	1.5	natural channel

$$t_c = \left( \frac{1400}{3.5} + \frac{1800}{1} + \frac{750}{1.5} \right) / 3600 = 0.74 \text{ hr.}$$

2) From Nomograph "Design of Small Dam," p.71

$$\Delta H = 1190 - 957 = 233 \quad L = 3900'$$

$$S = 210 / 3900 = 6.0\%$$

$$t_c = 0.22 \text{ hrs}$$

3) Using FAA Formula for surface flow (Airport Drainage)

$$T_c = \frac{1.8(1.1-C)\sqrt{L}}{\sqrt[3]{S}} = \frac{1.8(1.1-0.3)\sqrt{3900}}{\sqrt[3]{6.0}(60)} = 0.83$$

$$\text{Use } T_c = 0.60 \text{ HR.}$$

$$\text{Lag} = 0.6 T_c = 0.6(0.60) = 0.36 \text{ HR.}$$

FREDERIC R. HARRIS, INC.  
CONSULTING ENGINEERS

SUBJECT N.J. DAM SAFETY INSPECTION  
N.J. NO NAME 40 DAM  
COMPUTED BY C.L.C. CHECKED BY R.K.

SHEET NO. 4 OF 11  
JOB NO. 10-AB3-01  
DATE 1-25-80

ELEVATION-AREA-CAPACITY RELATIONSHIP

Data Estimated From U.S.G.S. Map

Elevation: (ft)	* 95.0	95.6	980	1000
Surface Area (Ac.)	0	25.7	42.2	82.7

\* Estimated lake bottom elevation at spillway

HEC-1 DB program will develop storage-capacity relationship from surface area & elevation data.

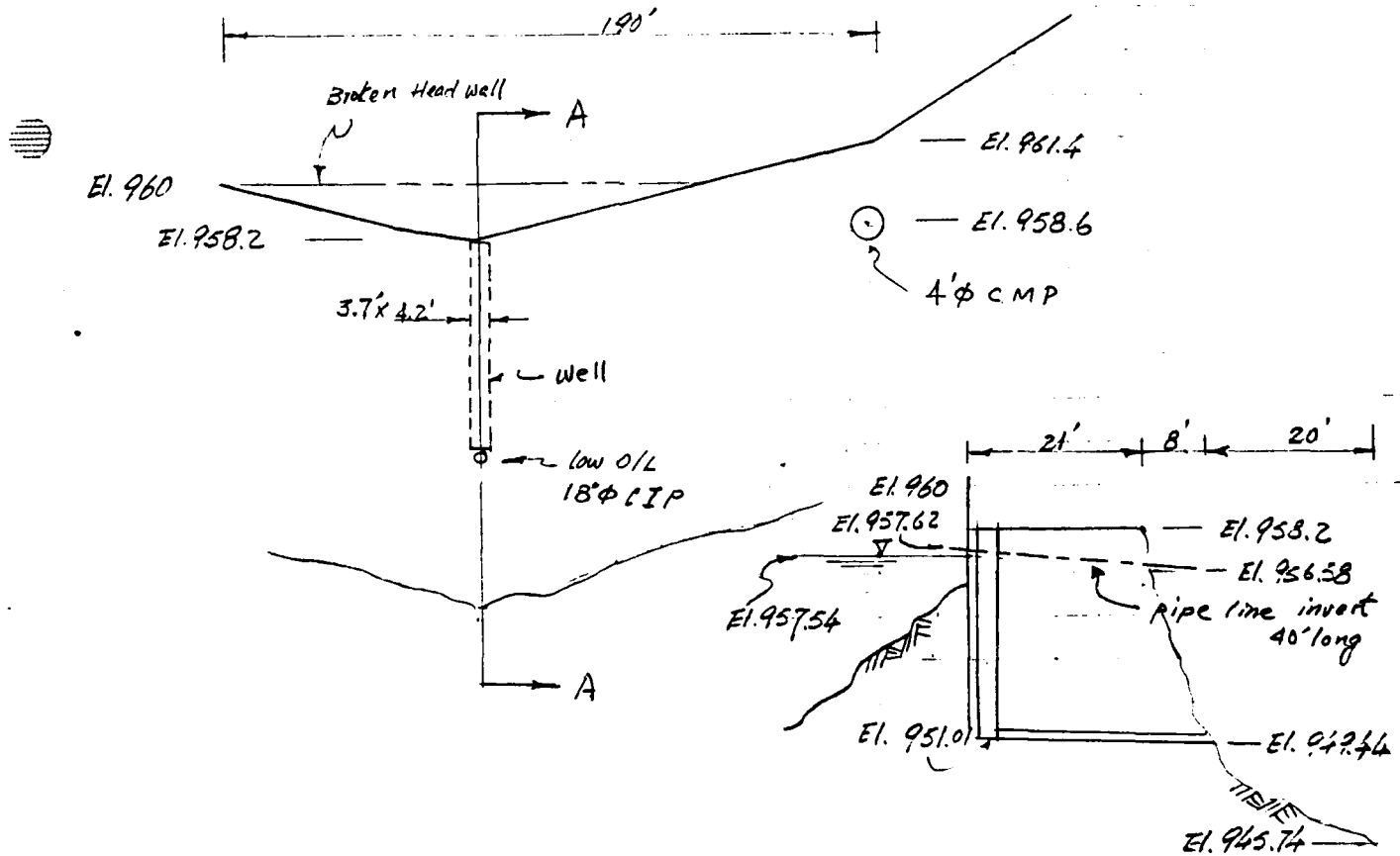

SECTION A-A

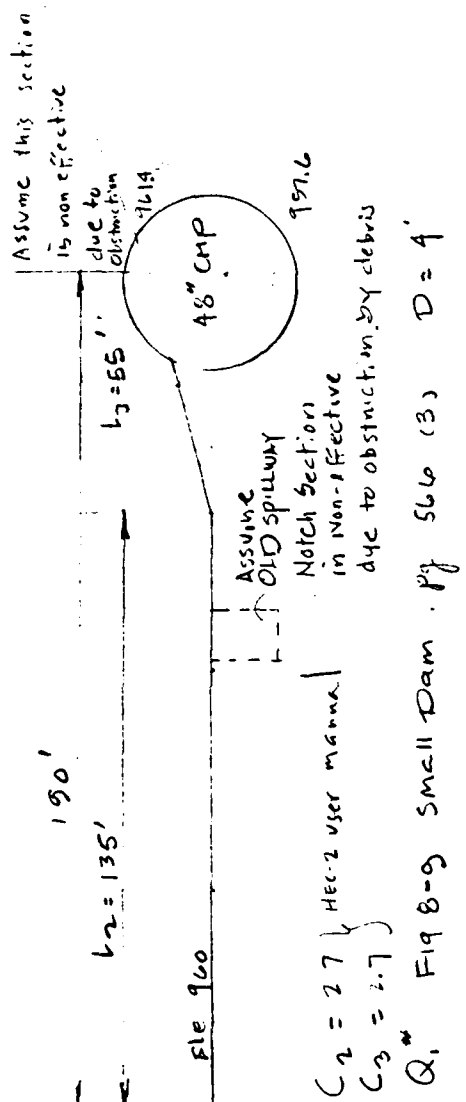

$\frac{H_1}{D}$	H <sub>2</sub>	H <sub>3</sub>	L <sub>1</sub>	L <sub>2</sub>	L <sub>3</sub>	C <sub>1</sub>	C <sub>2</sub>	C <sub>3</sub>	$Q = Q_1 + C_2 L_2 H_2^{1.5} + C_3 L_3 H_3^{1.5}$
0									0
0.25									14
0.5									21
0.6									30
0.75	0.6			135			2.7		42 + 169
0.78	0.7			135			2.7		45 + 214
0.95	1.4	0.7		135	55		2.7	2.7	60 + 604 + 87
1.1	2.0	1.3		135	55		2.7	2.7	73 + 1031 + 220
1.6	4.0	3.3		135	55		2.7	2.7	108 + 2916 + 890

0  
= 14  
= 21  
= 30  
= 211  
= 259  
= 751  
= 1324  
= 3914

PRC Harris, Inc.  
CONSULTING ENGINEERS

SUBJECT NJ Dam Insp Prog. Group VIII  
NJ No Name 40  
COMPUTED BY EK CHECKED BY \_\_\_\_\_

SHEET NO. 6 of 11  
JOB NO. 10-A93-01  
DATE 1/30/80

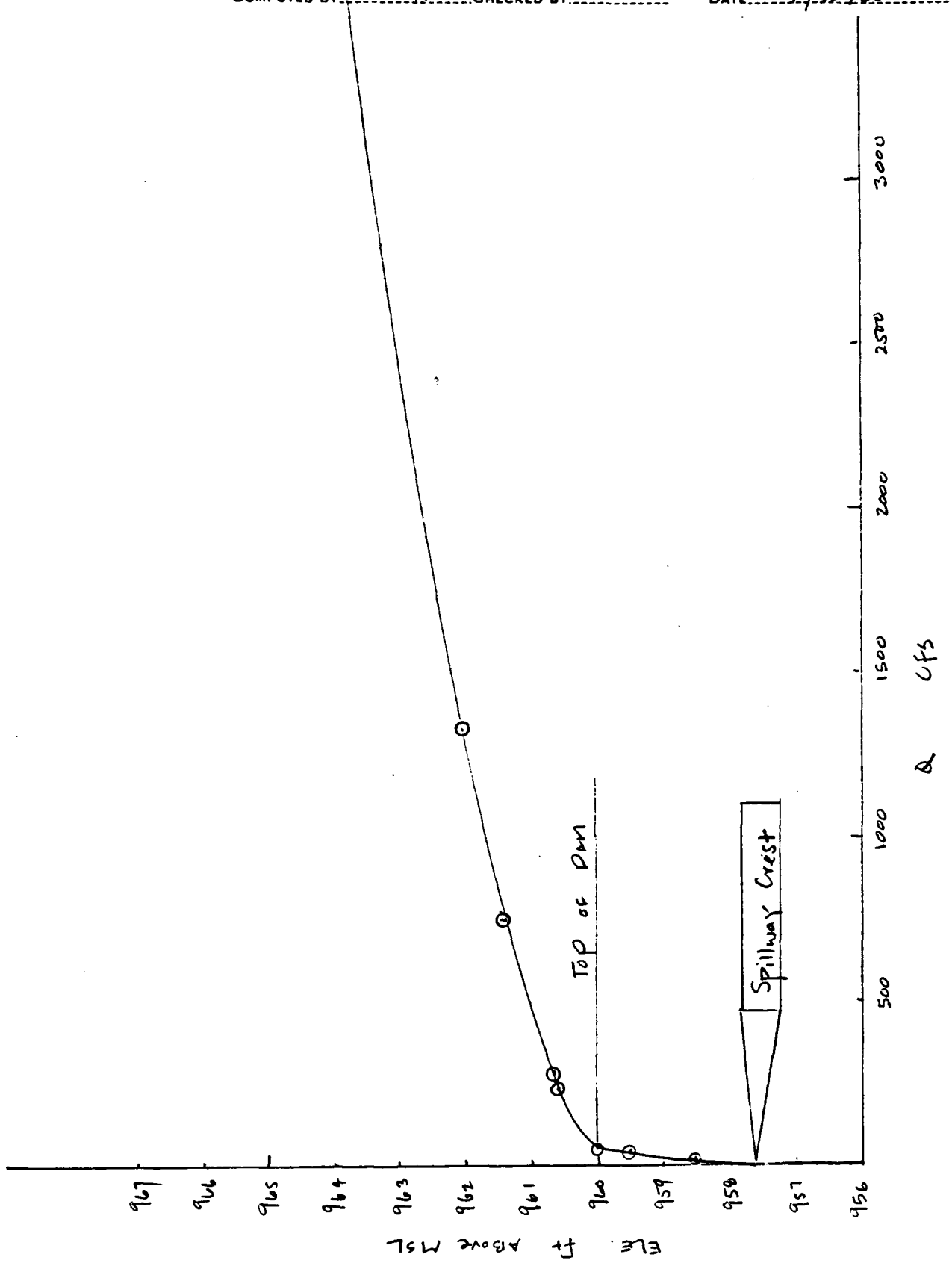

Overtopping Potential

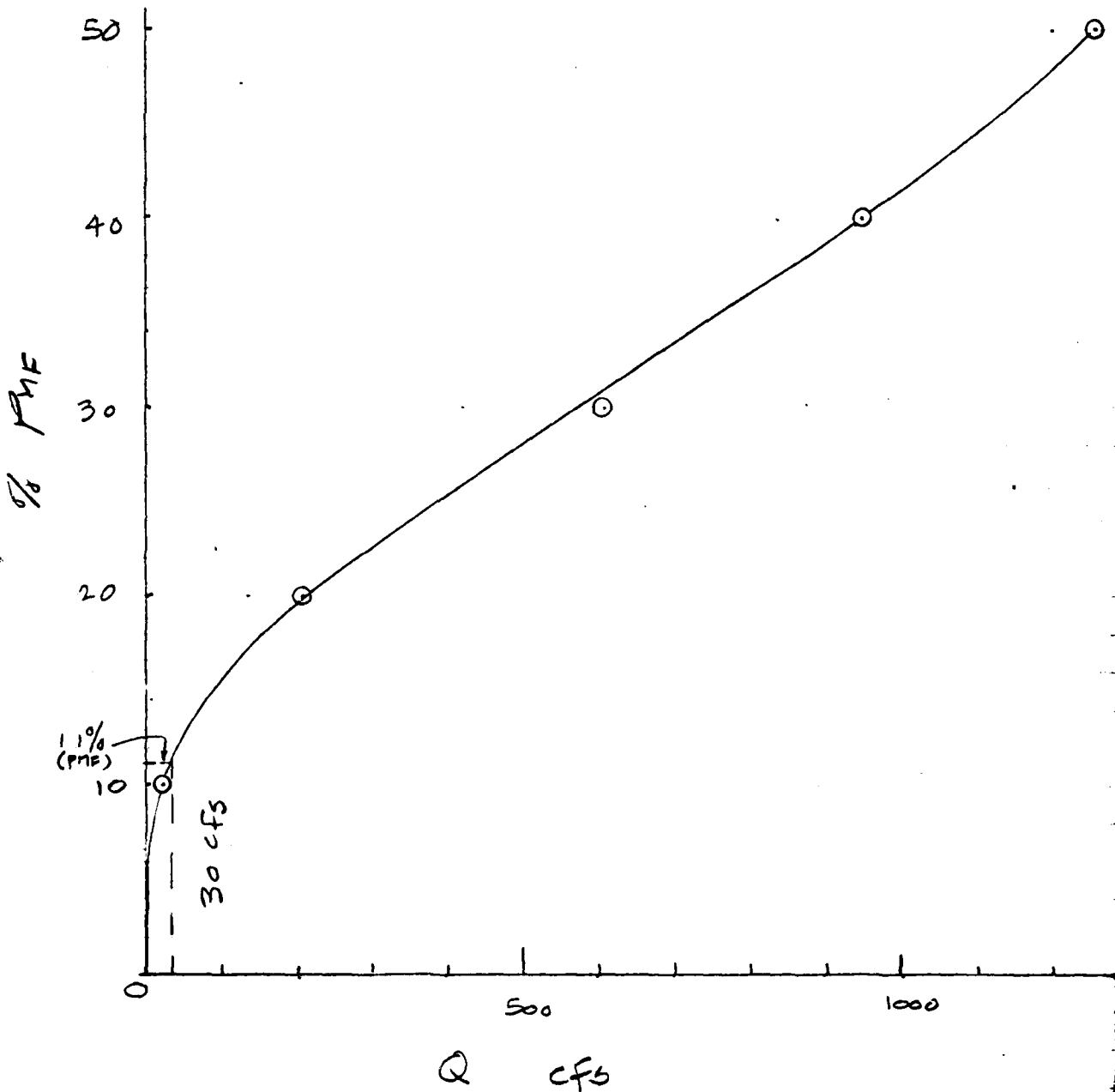

Overtopping of Dam occurs at Elev. 960 with  $Q = 30$  cfs ( $\sim 11\%$  PMF)

Sensitivity Analysis Summary

Breach width Ft	Side slope	Breach bottom Elev.	Fail time	Initial Water Surface Elev.	Ratio of PMF	Fail Elev.	D/S channel		Diff. Stag. Ft.
							Max. Stage with failure Ft	Stage w/no failure overlap Ft	
45	1	948	0.5	957.6	0.2	960.58	909.1	903.7	5.4
45	1	948	0.5	957.6	0.3	960.58	909.4	902.0	4.4
45	1	948	0.5	957.6	0.4	960.58	909.5	905.9	3.6
45	1	948	0.5	957.6	0.5	960.58	909.2	906.3	2.9

Breach Analysis

Based on Sensitivity analysis, the breach begins to develop when Lake Stage to reach Elev. 960.58 at 20% PMF with fail time = 0.5 hr.

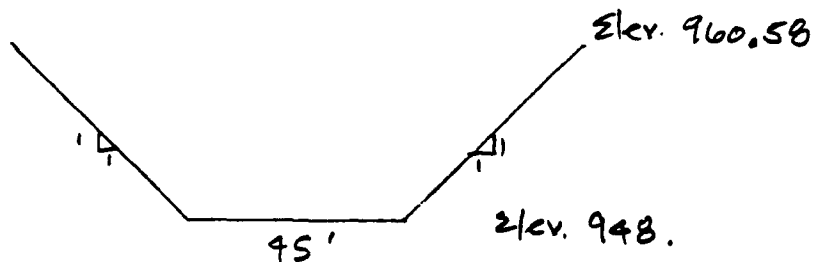

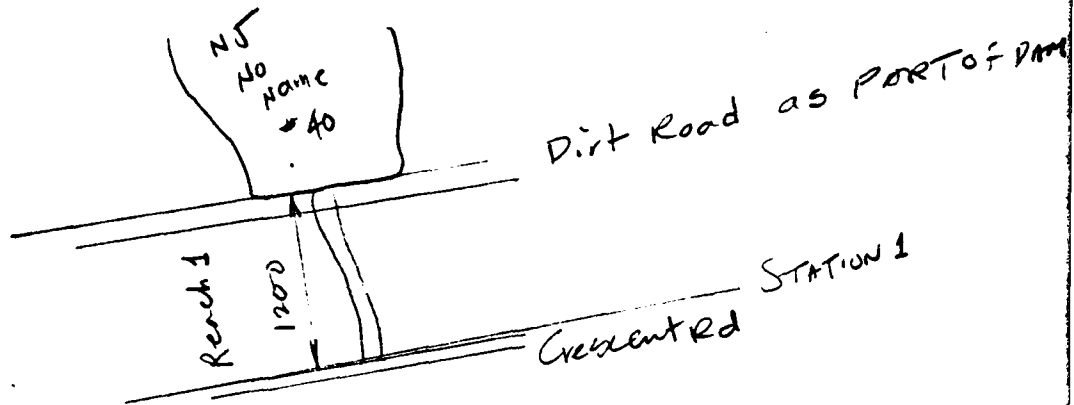

Assume Bridge across the Stream fails instantly upon impact of the flood wave.

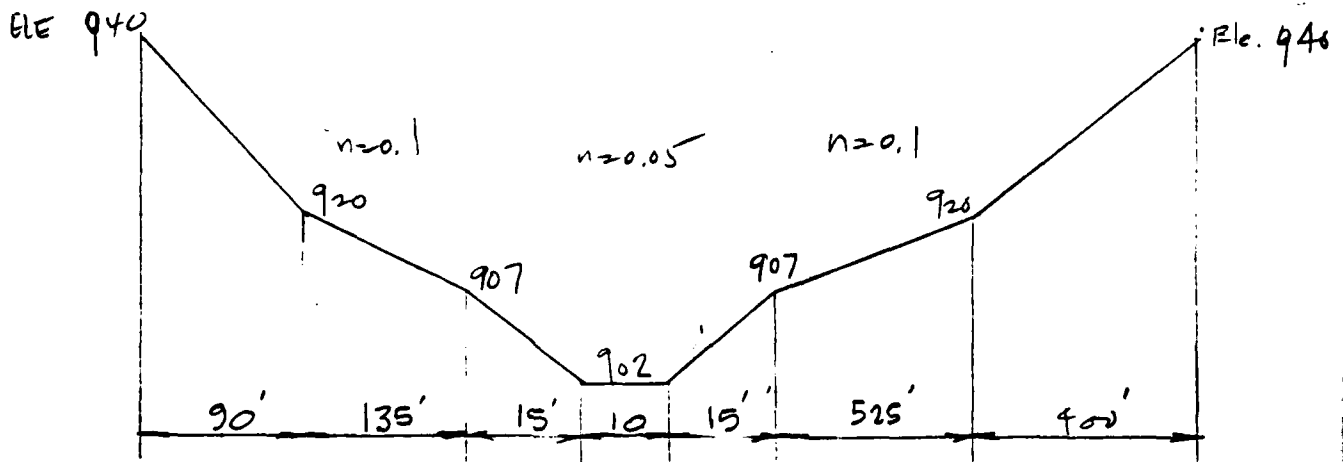

Cross-section

END of Reach 1

$$S = 0.042$$

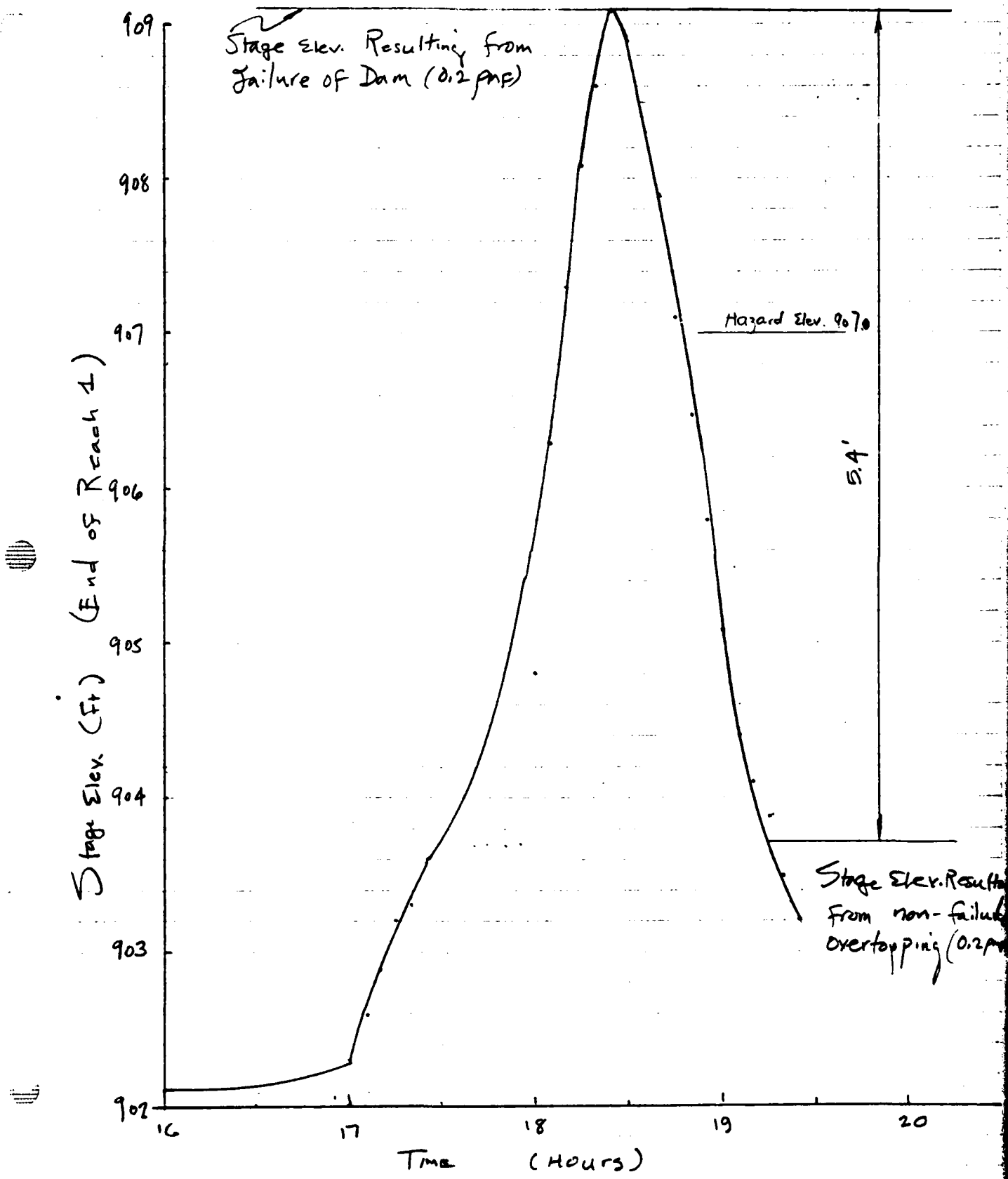

Drawdown time computation

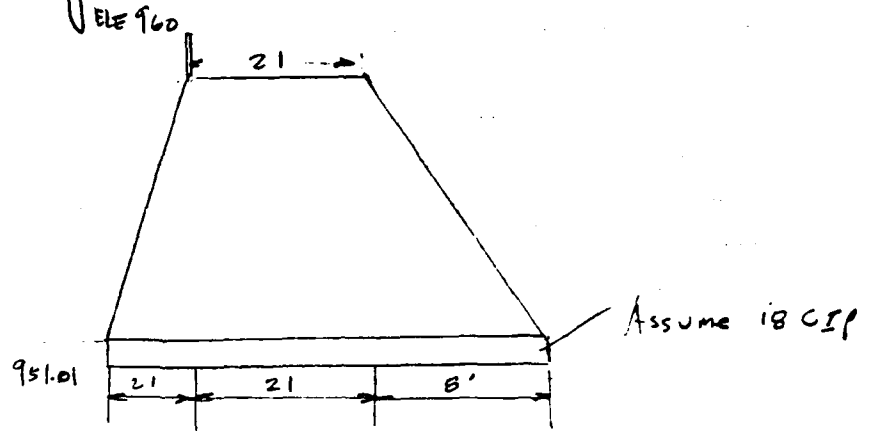

Assume total pipe length = 50'

Assume water starts to drain @ 956.6

$DH = 0.59 \text{ sq.}$        $1^{\text{st}} \text{ Flow} = 2 \times 0.59 = 1.08 \text{ cfs}$

Assume at half depth of outlet =  $951 + 0.75 = 951.75$

Res Ele	Area* Ac	Average Area Ac	Vol Ac-ft	Average H H	H/D	Q** Average outlet discharge	t <sub>1</sub> Time of drawdown $\frac{\text{Vol} \times 24}{1.48 \times Q}$	Cal time hr	t <sub>2</sub> $1.05 \times \frac{t_1}{a}$	Cal time hr
957.6	25.7									
		22.7	36.2	5.05	3.37	15.0	29.3	29.3	2.1	31.4
956.0	19.6									
		16.4	32.8	7.25	2.17	11.5	34.6	63.9	3.3	69.3
954.0	13.1									
		10.5	21.0	1.25	0.83	4.4	57.9	121.8	14.2	141.9
952.0	7.9									
		7.05	1.9	0.13	0.18	0.7	32.9	157.7	50.9	228.1
951.75	7.4									

A) TIME OF complete drawdown with no inflow = 157.7 hrs  $\approx$  7 days

B) TIME OF complete drawdown with inflow = 228.1 hrs  $\approx$  10 days

\*  $A_1 = \frac{A_2}{(H_1/H_2)^2}$        $H_1 + H_2 = 957.6 - 945 = 12.6$        $A_2 = 25.7 \text{ Ac}$

\*\* Q obtained from Fig 8-9 Pg. 566 design of Small dam

N I DAM SAFETY INSPECTION PROGRAM---GROUP XVII 10A8301  
 N J 00190 N.J. NO NAME #40 DAM, PASSAIC COUNTY, NJ  
 MUT RATIO ROUTING,FKC-HARRIS INC., WOODBRIDGE, N J  
 0 5 0 0 4

B1 5  
 J 1  
 J1 4  
 K 2  
 LANE 1  
 K 0  
 N1 1  
 N 2  
 F 25  
 T 99  
 W2 5  
 X -1  
 K 1  
 K1 1  
 Y 1

INFLOW HYDROGRAPH THROUGH N.J. NO NAME #40 DAM  
 54 0.8 1  
 99.5 110 118 1.0 0.10  
 0.36  
 -.05  
 DAM  
 ROUTING DISCHARGE THROUGH DAM  
 1 1  
 957.6 959.6 960 960.6 960.7 961.4 962.0 964.0  
 14 21 30 211 259 751 1324 3914  
 957.6 42.2 82.7 980 1000  
 957.6 960 99

Y1 1  
 Y4 957.6  
 Y5 0  
 Y6 0  
 Y7 945  
 Y8 957.6  
 Y9 960  
 Y10 99  
 Y11 99

N J DAM SAFETY INSPECTION PROGRAM--GROUP XVII 10A8301  
N J 00190 N J NO NAME #40 DAM, PASSAIC COUNTY, N J  
MULTI RATIO ROUTING, PRC-HARRIS INC., WOODBRIDGE, N J

NO 288 NHK 0 NMIN 5 IDAY 0 IMIN 0 METK 0 IFLT 0 IFRT 4 NSTAN 0  
JOFER 0 NMT 0 LKOPT 0 IRACE 0  
JOB SPECIFICATION

MULTI-PLAN ANALYSES TO BE PERFORMED  
NFLAN= 1 NRTO= 5 LRTO= 1

RTIOS= 50 40 30 20 10

\*\*\*\*\* \*\*\*\*\* \*\*\*\*\* \*\*\*\*\* \*\*\*\*\*

SUB-AREA RUNOFF COMPUTATION

INFLOW HYDROGRAPH THROUGH N J NO NAME #40 DAM

I STAQ 0 ICOMP 0 IFCN 0 ITAPE 0 JPLT 0 JFRT 0 INAME 1 ISTAGE 0 IAUTO 0  
LAKE 0 TAREA 54 0.00 SNAP TRSDA TRSPC RATIO ISNOW 0 ISAME 1 LDCN 0

HYDROGRAPH DATA  
PRECIP DATA  
R6 R12 R24 R48 R72 R96  
0.00 25.00 99.50 110.00 118.00 0.00 0.00 0.00 0.00

LOSS DATA

SIRK 0 DLTKR 0.00 RTIOL 1.00 ERAIN SIRKS RTIOK SIRTL CNSL ALSHX RTIMP  
0.00 0.00 0.00 0.00 0.00 1.00 1.00 10 0.00 0.00  
UNIT HYDROGRAPH DATA  
TC= 0.00 LAG= 36

RECESSION DATA  
STRIO= -1.00 DRCSN= .05 RTIOR= 2.00

57 217 84 3 452 60 1 616 43 0 504 22 473 16 525 11 56 277 8 908 1 00 164 6  
 118 4 69 60 1 616 43 0 504 22 473 16 525 11 56 277 8 908 1 00 164 6

MO	DA	IN	AM	PERIOD	RATE	EXCS	LOSS	COMP	END OF PERIOD FLOW	MO	DA	IN	AM	PERIOD	RATE	EXCS	LOSS	COMP
1	01	1	05	1	01	0 00	01	1	1 01	12	07	145	17	16	01	97		
1	01	1	10	2	01	0 00	01	0	1 01	12	10	146	17	16	01	124		
1	01	1	15	3	01	0 00	01	0	1 01	12	15	147	17	16	01	180		
1	01	1	20	4	01	0 00	01	0	1 01	12	20	148	17	16	01	222		
1	01	1	25	5	01	0 00	01	0	1 01	12	25	149	17	16	01	341		
1	01	1	30	6	01	0 00	01	0	1 01	12	30	150	17	16	01	430		
1	01	1	35	7	01	0 00	01	0	1 01	12	35	151	17	16	01	505		
1	01	1	40	8	01	0 00	01	0	1 01	12	40	152	17	16	01	549		
1	01	1	45	9	01	0 00	01	0	1 01	12	45	153	17	16	01	580		
1	01	1	50	10	01	0 00	01	0	1 01	12	50	154	17	16	01	603		
1	01	1	55	11	01	0 00	01	0	1 01	12	55	155	17	16	01	619		
1	01	1	00	12	01	0 00	01	0	1 01	13	00	156	17	16	01	640		
1	01	1	05	13	01	0 00	01	0	1 01	13	05	157	20	19	01	641		
1	01	1	10	14	01	0 00	01	0	1 01	13	10	158	20	19	01	654		
1	01	1	15	15	01	0 00	01	0	1 01	13	15	159	20	19	01	673		
1	01	1	20	16	01	0 00	01	0	1 01	13	20	160	20	19	01	698		
1	01	1	25	17	01	0 00	01	0	1 01	13	25	161	20	19	01	720		
1	01	1	30	18	01	0 00	01	0	1 01	13	30	162	20	19	01	741		
1	01	1	35	19	01	0 00	01	0	1 01	13	35	163	20	19	01	758		
1	01	1	40	20	01	0 00	01	0	1 01	13	40	164	20	19	01	769		
1	01	1	45	21	01	0 00	01	0	1 01	13	45	165	20	19	01	777		
1	01	1	50	22	01	0 00	01	0	1 01	13	50	166	20	19	01	785		
1	01	1	55	23	01	0 00	01	0	1 01	13	55	167	20	19	01	797		
1	01	2	00	24	01	0 00	01	0	1 01	14	00	168	20	19	01	790		
1	01	2	05	25	01	0 00	01	0	1 01	14	05	169	25	24	01	796		
1	01	2	10	26	01	0 00	01	0	1 01	14	10	170	25	24	01	808		
1	01	2	15	27	01	0 00	01	0	1 01	14	15	171	25	24	01	831		
1	01	2	20	28	01	0 00	01	0	1 01	14	20	172	25	24	01	863		
1	01	2	25	29	01	0 00	01	0	1 01	14	25	173	25	24	01	895		
1	01	2	30	30	01	0 00	01	0	1 01	14	30	174	25	24	01	925		
1	01	2	35	31	01	0 00	01	0	1 01	14	35	175	25	24	01	949		
1	01	2	40	32	01	0 00	01	0	1 01	14	40	176	25	24	01	965		
1	01	2	45	33	01	0 00	01	0	1 01	14	45	177	25	24	01	976		
1	01	2	50	34	01	0 00	01	0	1 01	14	50	178	25	24	01	985		
1	01	2	55	35	01	0 00	01	0	1 01	14	55	179	25	24	01	991		
1	01	3	00	36	01	0 00	01	0	1 01	15	00	180	25	24	01	995		
1	01	3	05	37	01	0 00	01	0	1 01	15	05	181	25	24	01	991		
1	01	3	10	38	01	0 00	01	0	1 01	15	10	182	30	29	01	987		
1	01	3	15	39	01	0 00	01	0	1 01	15	15	183	30	29	01	973		
1	01	3	20	40	01	0 00	01	0	1 01	15	20	184	45	45	01	993		
1	01	3	25	41	01	0 00	01	0	1 01	15	25	185	53	52	01	1061		
1	01	3	30	42	01	0 00	01	0	1 01	15	30	186	1 29	1 28	01	1740		
1	01	3	35	43	01	0 00	01	0	1 01	15	35	187	2 12	2 11	01	1632		
1	01	3	40	44	01	0 00	01	0	1 01	15	40	188	83	82	01	2249		
1	01	3	45	45	01	0 00	01	0	1 01	15	45	189	53	52	01	2955		
1	01	3	50	46	01	0 00	01	0	1 01	15	50	190	45	45	01	5439		
1	01	3	55	47	01	0 00	01	0	1 01	15	55	191	30	29	01	5567		
1	01	4	00	48	01	0 00	01	0	1 01	16	00	192	40	39	01	3300		

1.01	4.00	47	01	0.00	01	0	1.01	16.05	194	25	22	01	3010
1.01	4.10	50	01	0.00	01	0	1.01	16.10	194	23	22	01	2546
1.01	4.15	51	01	0.00	01	0	1.01	16.15	195	23	22	01	2130
1.01	4.20	52	01	0.00	01	0	1.01	16.20	196	25	22	01	1036
1.01	4.25	53	01	0.00	01	0	1.01	16.25	197	23	22	01	1590
1.01	4.30	54	01	0.00	01	0	1.01	16.30	198	23	22	01	1404
1.01	4.35	55	01	0.00	01	0	1.01	16.35	199	23	22	01	1289
1.01	4.40	56	01	0.00	01	0	1.01	16.40	200	23	22	01	1174
1.01	4.45	57	01	0.00	01	0	1.01	16.45	201	23	22	01	1105
1.01	4.50	58	01	0.00	01	0	1.01	16.50	202	23	22	01	1037
1.01	4.55	59	01	0.00	01	0	1.01	16.55	203	23	22	01	1022
1.01	5.00	60	01	0.00	01	0	1.01	17.00	204	23	22	01	997
1.01	5.05	61	01	0.00	01	0	1.01	17.05	205	10	17	01	976
1.01	5.10	62	01	0.00	01	0	1.01	17.10	206	18	17	01	953
1.01	5.15	63	01	0.00	01	0	1.01	17.15	207	18	17	01	921
1.01	5.20	64	01	0.00	01	0	1.01	17.20	208	18	17	01	884
1.01	5.25	65	01	0.00	01	0	1.01	17.25	209	18	17	01	845
1.01	5.30	66	01	0.00	01	0	1.01	17.30	210	18	17	01	811
1.01	5.35	67	01	0.00	01	0	1.01	17.35	211	18	17	01	785
1.01	5.40	68	01	0.00	01	0	1.01	17.40	212	19	17	01	768
1.01	5.45	69	01	0.00	01	0	1.01	17.45	213	18	17	01	756
1.01	5.50	70	01	0.00	01	0	1.01	17.50	214	18	17	01	748
1.01	5.55	71	01	0.00	01	0	1.01	17.55	215	18	17	01	742
1.01	6.00	72	01	0.00	01	0	1.01	18.00	216	18	17	01	738
1.01	6.05	73	03	0.00	03	0	1.01	18.05	217	01	00	01	723
1.01	6.10	74	03	0.00	03	0	1.01	18.10	218	01	00	01	684
1.01	6.15	75	03	0.00	03	0	1.01	18.15	219	01	00	01	606
1.01	6.20	76	03	0.00	03	0	1.01	18.20	220	01	00	01	501
1.01	6.25	77	03	0.00	03	0	1.01	18.25	221	01	00	01	391
1.01	6.30	78	03	0.00	03	0	1.01	18.30	222	01	00	01	292
1.01	6.35	79	03	0.00	03	0	1.01	18.35	223	01	00	01	211
1.01	6.40	80	03	0.00	03	0	1.01	18.40	224	01	00	01	173
1.01	6.45	81	03	0.00	03	0	1.01	18.45	225	01	00	01	162
1.01	6.50	82	03	0.00	03	0	1.01	18.50	226	01	00	01	151
1.01	6.55	83	03	0.00	03	0	1.01	18.55	227	01	00	01	141
1.01	7.00	84	03	0.00	03	0	1.01	19.00	228	01	00	01	131
1.01	7.05	85	03	0.01	02	1	1.01	19.05	229	01	00	01	124
1.01	7.10	86	03	0.02	01	4	1.01	19.10	230	01	00	01	114
1.01	7.15	87	03	0.02	01	12	1.01	19.15	231	01	00	01	107
1.01	7.20	88	03	0.02	01	24	1.01	19.20	232	01	00	01	100
1.01	7.25	89	03	0.02	01	37	1.01	19.25	233	01	00	01	93
1.01	7.30	90	03	0.02	01	50	1.01	19.30	234	01	00	01	87
1.01	7.35	91	03	0.02	01	60	1.01	19.35	235	01	00	01	81
1.01	7.40	92	03	0.02	01	68	1.01	19.40	236	01	00	01	75
1.01	7.45	93	03	0.02	01	74	1.01	19.45	237	01	00	01	70
1.01	7.50	94	03	0.02	01	77	1.01	19.50	238	01	00	01	66
1.01	7.55	95	03	0.02	01	80	1.01	19.55	239	01	00	01	61
1.01	8.00	96	03	0.02	01	82	1.01	20.00	240	01	00	01	57



\*\*\*\*\*  
\*\*\*\*\*  
\*\*\*\*\*  
\*\*\*\*\*  
\*\*\*\*\*

PLAN FLOW AND STORAGE (END OF PERIOD) SUMMARY FOR MULTIPLE PLAN-RATIO ECONOMIC COMPUTATIONS  
 FLOWS IN CUBIC FEET PER SECOND (CUBIC METERS PER SECOND)  
 AREA IN SQUARE MILES (SQUARE KILOMETERS)

OPERATION	STATION	AREA	PLAN	RATIOS APPLIED TO FLOWS				
				RATIO 1	RATIO 2	RATIO 3	RATIO 4	RATIO 5
HYDROGRAPH AT	LANE	.54 ( 1.40)	1	1781. ( 50.43)	1425. ( 40.34)	1069. ( 30.26)	712. ( 20.17)	356. ( 10.09)
ROUTED TO	DAM	.54 ( 1.40)	1	1292. ( 36.60)	982. ( 27.80)	615. ( 17.41)	205. ( 5.81)	21. ( .59)

SUMMARY OF DAM SAFETY ANALYSIS

PLAN 1	ELEVATION STORAGE OUTFLOW	INITIAL VALUE	SPILLWAY CREST	TUF OF DAM	DURATION OVER TOP HOURS	MAXIMUM OUTFLOW CFS	MAXIMUM STORAGE AC-FT	MAXIMUM DEPTH OVER DAM	MAXIMUM RESERVOIR W.S. ELEV	TIME OF FAILURE HOURS	TIME OF MAX OUTFLOW HOURS
		957.60	957.60	960.00	7.67	1292.	226.	1.97	961.97	16.17	16.17
		108.	108.	171.	7.00	982.	217.	1.64	961.64	16.17	16.17
		0.	0.	30.	5.92	615.	205.	1.21	961.21	16.25	16.25
					4.83	205.	187.	.58	960.58	16.92	16.92
					0.00	21.	160.	0.00	959.58	18.58	18.58

\*\*\*\*\*  
 C:\DDP\B\BEGG\BEGG.DDU DAMAGE JUNE 11

N J DAM SAFETY INSPECTION PROGRAM---GROUP XVII 10A8301  
 N J 00190 N.J. NO NAME #40 DAM, PASSAIC COUNTY, NJ  
 MULTI RATIO ROUTING, PRC-HARRIS INC. / WOODBRIDGE, N.J.

NO	DESCRIPTION	1	2	3	4	5	6	7	8	9	10
A1											
A2											
A3											
B	288	0	5	0	0	0	0	0	0	0	1
B1	5	1	1								
J1	2										
K	0										
K1											
M	1	2	54	54	0.8	1					
P		25	99.5	110	118						
W2		0.36									1.0
X	-1										0.10
K	1										
K1											
Y											
Y1	1										
Y4	957.6	958.6	959.6	960	960.6	960.7	1961.4	962.0	964.0		
Y5	0	14	21	30	211	259	751	1324	3914		
Y6	0	25.7	42.2	82.7							
Y8	945	957.6	980	1000							
Y9	957.6										
Y10	960										
Y11	45	1	948	0.5	957.6	990.00					
Y12	45	1	948	0.5	957.6	960.58					
Y13	1										
Y14	1										
Y15	1										
Y16	1160	907	1750	920	1885	907	1900	902	1910	902	
Y17	1925	907	2450	920	2850	940					
Y18	99										
Y19											
Y20											
Y21											
Y22											
Y23											
Y24											
Y25											
Y26											
Y27											
Y28											
Y29											
Y30											
Y31											
Y32											
Y33											
Y34											
Y35											
Y36											
Y37											
Y38											
Y39											
Y40											
Y41											
Y42											
Y43											
Y44											
Y45											
Y46											
Y47											
Y48											
Y49											
Y50											
Y51											
Y52											
Y53											
Y54											
Y55											
Y56											
Y57											
Y58											
Y59											
Y60											
Y61											
Y62											
Y63											
Y64											
Y65											
Y66											
Y67											
Y68											
Y69											
Y70											
Y71											
Y72											
Y73											
Y74											
Y75											
Y76											
Y77											
Y78											
Y79											
Y80											
Y81											
Y82											
Y83											
Y84											
Y85											
Y86											
Y87											
Y88											
Y89											
Y90											
Y91											
Y92											
Y93											
Y94											
Y95											
Y96											
Y97											
Y98											
Y99											
Y100											

ROUTING DISCHARGE THROUGH DAM  
 REACH1  
 CHANNEL ROUTING

STATION DAM

(C) INTERPOLATED BREACH HYDROGRAPH (\*) POINTS AT NORMAL TIME INTERVAL

(D) COMPUTED BREACH HYDROGRAPH

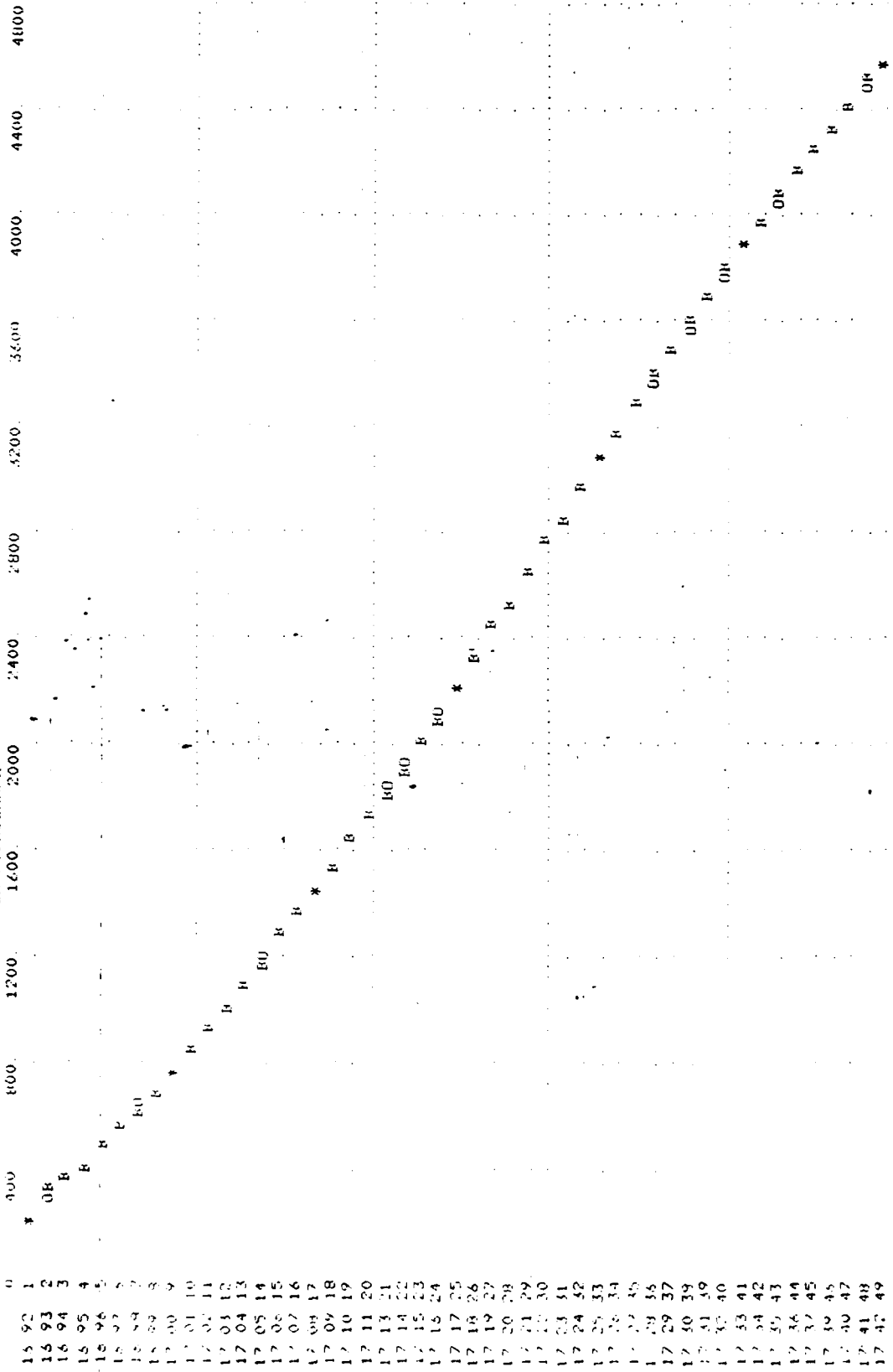

18-0000

\*\*\*\*\*

HYDROGRAPH ROUTING

\*\*\*\*\*

CHANNEL ROUTING

ISLAG ICOMP IRECON ITAPE JFILT JFRT INAME IJSTAGE JAU10

0 0 0 0 0 0 0 0 0 0 0 0

REACH1 1

ALL PLANS HAVE SAME ROUTING DATA

IKES ISAME IDPT IPMP ISIR

0 0 0 0 0 0

NS1FS NS1DL IAG AMSKK X YSK S10R0 ESPROT

1 0 0 0 0 0 0 0 0 0 0

\*\*\*\*\*

GENERAL DEPTH CHANNEL ROUTING

GN(1)	GN(2)	GN(3)	FINVT	ELMAX	R1NTH	SEL
1000	0500	1000	902.0	940.0	1200	04200
0 00	177.25	223.99	2.42	276.20	5.24	13.04
0 00	246.07	988.12	988.12	2572.82	333.86	396.97
97022.59	130037.07	169311.27	169311.27	215164.62	5791.30	11378.68
902.00	904.00	904.00	904.00	908.00	910.00	912.00
922.00	924.00	924.00	926.00	928.00	930.00	932.00
97022.59	130037.07	169311.27	169311.27	215164.62	5791.30	11378.68
0 00	246.07	988.12	988.12	2572.82	333.86	396.97
97022.59	130037.07	169311.27	169311.27	215164.62	5791.30	11378.68
STORAGE	0 00	177.25	223.99	2.42	276.20	5.24
OUTFLOW	0 00	246.07	988.12	988.12	2572.82	333.86
STAGE	902.00	904.00	904.00	908.00	910.00	912.00
FLOW	922.00	924.00	926.00	928.00	930.00	932.00
	97022.59	130037.07	169311.27	215164.62	5791.30	11378.68
	0 00	246.07	988.12	988.12	2572.82	333.86
	97022.59	130037.07	169311.27	215164.62	5791.30	11378.68
	100.10	703.97	70.00	619.04	45.42	539.56
	48636.20	555728.08	32323.87	471568.89	20021.90	395791.55
	918.00	938.00	916.00	936.00	914.00	914.00
	48836.20	555728.08	32323.87	471568.89	20021.90	395791.55
	70073.94	648619.69	70073.94	648619.69	70073.94	648619.69



DATE

ILMED

-88