

AD-A087 95A

ARMY ELECTRONICS RESEARCH AND DEVELOPMENT COMMAND FO--ETC F/6 9/1  
DESIGN: FABRICATION AND EVALUATION OF LOW COST DIODE OSCILLATOR--ETC(U)  
APR 80 E E MALECKI, H JACOBS  
DELET-TR-80-8

UNCLASSIFIED

NL

1 of 1  
FOIA  
b7c



END  
DATE  
FILMED  
9-80  
DTIC



**LEVEL**

10  
B.S.

RESEARCH AND DEVELOPMENT TECHNICAL REPORT  
DELET-TR-80-8

AD A087954

DESIGN, FABRICATION AND EVALUATION OF LOW COST DIODE  
OSCILLATOR FOR MILLIMETER WAVES

Edmund E. Malecki  
Harold Jacobs  
ELECTRONICS TECHNOLOGY & DEVICES LABORATORY

April 1980

DTIC  
ELECTE  
AUG 18 1980  
S D C

DISTRIBUTION STATEMENT  
Approved for public release;  
distribution unlimited.

**ERADCOM**

US ARMY ELECTRONICS RESEARCH & DEVELOPMENT COMMAND  
FORT MONMOUTH, NEW JERSEY 07703

DDC FILE COPY

80 8 15 009

HISA-FM 196-78

## NOTICES

### Disclaimers

The citation of trade names and names of manufacturers in this report is not to be construed as official Government indorsement or approval of commercial products or services referenced herein.

### Disposition

Destroy this report when it is no longer needed. Do not return it to the originator.

UNCLASSIFIED

SECURITY CLASSIFICATION OF THIS PAGE (When Data Entered)

<b>REPORT DOCUMENTATION PAGE</b>		<b>7</b> READ INSTRUCTIONS BEFORE COMPLETING FORM
<b>1</b> REPORT NUMBER DELET-TR-86-8	<b>2</b> GOVT ACCESSION NO. AD A087954	<b>3</b> RECIPIENT'S CATALOG NUMBER Research and development
<b>4</b> TITLE (and Subtitle) DESIGN, FABRICATION AND EVALUATION OF LOW COST DIODE OSCILLATOR FOR MILLIMETER WAVES		<b>5</b> TYPE OF REPORT AND DATED TECHNICAL REPORT
<b>7</b> AUTHOR(s) EDMUND E. MALECKI HAROLD JACOBS		<b>8</b> CONTRACT OR GRANT NUMBER(s) N/A 17 07
<b>9</b> PERFORMING ORGANIZATION NAME AND ADDRESS USA ELECTRONICS RESEARCH & DEVELOPMENT COMMAND ERADCOM ATTN: DELET-MJ FORT MONMOUTH, NJ 07703		<b>10</b> PROGRAM ELEMENT, PROJECT, TASK AREA & WORK UNIT NUMBERS 1162705AH94 07
<b>11</b> CONTROLLING OFFICE NAME AND ADDRESS		<b>12</b> REPORT DATE 11 Apr 80
<b>14</b> MONITORING AGENCY NAME & ADDRESS (if different from Controlling Office) 12 18		<b>13</b> NUMBER OF PAGES 14
		<b>15</b> SECURITY CLASS. (of this report) UNCLASSIFIED
		<b>15a</b> DECLASSIFICATION/DOWNGRADING SCHEDULE
<b>16</b> DISTRIBUTION STATEMENT (of this Report) APPROVED FOR PUBLIC RELEASE: DISTRIBUTION UNLIMITED.		
<b>17</b> DISTRIBUTION STATEMENT (of the abstract entered in Block 20, if different from Report)		
<b>18</b> SUPPLEMENTARY NOTES		
<b>19</b> KEY WORDS (Continue on reverse side if necessary and identify by block number) GUNN DIODES, OSCILLATORS, CAVITY DESIGN, MILLIMETER-WAVES, DIELECTRIC WAVEGUIDE		
<b>20</b> ABSTRACT (Continue on reverse side if necessary and identify by block number) There are urgent requirements for millimeter-wave oscillators in the range of 60 GHz, particularly for local oscillators, receivers, and low power transmit/receive applications such as the self-oscillating mixer. This report describes the design, fabrication and evaluation of a low cost Gunn diode oscillator structure where the diode is placed adjacent to a dielectric waveguide, which in turn, provides output coupling for radiation. Ten milliwatt output power was obtained from a diode at a frequency of 60 GHz.		

410698 2W

**SECURITY CLASSIFICATION OF THIS PAGE(When Data Entered)**

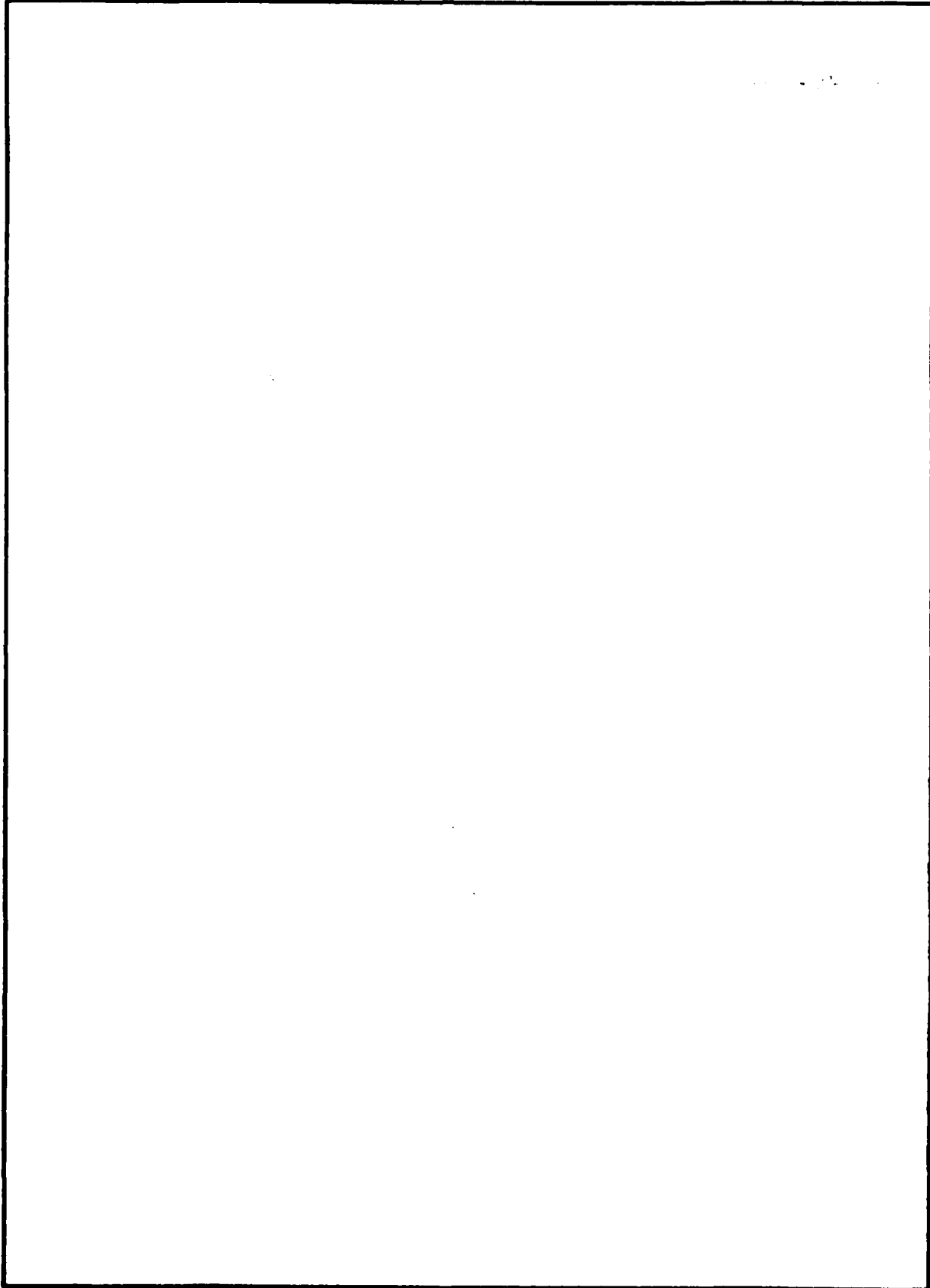

**SECURITY CLASSIFICATION OF THIS PAGE(When Data Entered)**

CONTENTS

	<u>Page</u>
INTRODUCTION	1
CIRCUIT DESIGN AND PACKAGING	1
DATA	2
DISCUSSION	2
CONCLUSIONS	3
ACKNOWLEDGEMENTS	3

TABLES

1	Test Results GaAs Gunn Diode Assembled on Metal Block With 0.2540cm (0.1000 in.) Diameter Disc Attached to Anode	4
2	Pellet Form GaAs Gunn Diode Assembled on Metal Block	5
3	Pellet Form GaAs Gunn Diode Assembled on Metal Block	6
4	GaAs Gunn Diode	7

FIGURES

1	Gunn Diode Packaged in Pellet Form	8
2	Pellet Diode Soldered to Metal Block for Base Bending and Heat Sink	9
3	Dielectric Waveguide and Transformer Strips Bonded on Heat Sink and Carrier Substrate	10
4	Diode Assembly Inclosed Within Rectangular Waveguide	11
5	Modified RF Connector With Discs	12
6	Diode Mounted in Metal Box	13
7	Gunn Oscillator Construction	14

Accession For	
NTIS GRA&I	<input checked="" type="checkbox"/>
DDC TAB	<input type="checkbox"/>
Unannounced	<input type="checkbox"/>
Justification	<input type="checkbox"/>
By _____	
Distribution/ _____	
Availability Codes	
Dist	Avail and/or special
<b>A</b>	

DESIGN, FABRICATION AND EVALUATION OF  
LOW COST DIODE OSCILLATOR FOR MILLIMETER-WAVES

INTRODUCTION

This project was undertaken to demonstrate the feasibility of fabricating a low cost diode oscillator.<sup>1</sup> Indium Phosphide and gallium arsenide diodes were designed into a package where sufficient power was obtained for applications to the development of low power transmitter/receivers. Present day oscillators consist of a diode (Gunn or IMPATT) mounted in a metal cavity, costing about \$3,000 for a single unit because of precision machining required for the cavity walls. The aim of this project was to design a low cost, simplified circuit package where maximum power could be obtained from the Gunn diode at a desired frequency with nearly fixed impedance so that little or no tuning is required.

CIRCUIT DESIGN AND PACKAGING

Preliminary design and packaging was directed toward establishing the relative locations of components to minimize power loss, due to radiation, in the passive dielectric transmission line and the oscillating diode region. A detailed illustration (Fig. 1) shows the basic solid state oscillator diode's structural design and package in pellet form. It is a gallium arsenide or indium phosphide solid state diode approximately 0.0102cm x 0.0102cm x 0.0051cm (0.004 in. x 0.004 in. x 0.002 in.) and is eutectically bonded to a gold-plated copper disc cover approximately 0.0889cm (0.035 in.) in diameter. The device is surrounded by a quartz ring 0.0127cm (0.005 in.) high with a 0.0127cm (0.005 in.) thick wall. The anode or top of the diode is interconnected with gold ribbon 0.0051cm x 0.0025cm (0.002 in. x 0.001 in.) to the top surface of the quartz ring. The assembly is capped with the gold-plated copper disc. The Gunn diode oscillator, in pellet form, as shown in Figure 2, is then soldered in a small vertical hole drilled in a gold-plated copper block 1.3462cm x 0.7620cm x 0.2540cm (0.530 in. x 0.300 in. x 0.100 in.) for base bonding and also serves as a heat sink. The pellet diode is soldered in the cavity with 60-37-3 silver solder at 220°C. The next assembly step consists of bonding a dielectric waveguide adjacent to the diode and then bonding the diode with dielectric waveguide and heat sink on a 2.5400cm x 0.0508cm (1.000 in. x 0.020 in.) gold-plated alumina carrier substrate (Fig. 3). The dielectric waveguide tapered at one end is machined from alumina, is 2.540cm (1.000 in.) long, 0.3048cm (0.120 in.) wide, and 0.1016cm (0.040 in.) thick. By utilizing impedance transformer concepts and subsequent experimentation, it was found that by placing metal strips along the dielectric waveguide's upper surface, power output can be increased significantly. On the top part of the dielectric waveguide two metal strips 0.2032cm (0.080 in.) wide were placed alongside each other spaced 0.0127cm (0.005 in.) apart; in addition, a metal strip 0.0254cm (0.010 in.) wide was placed beside the dielectric, adjacent to the diode. The metal strips serve as transformers to match the diode and resonant disc to the dielectric transmission lines. The diode structure was then inclosed in a rectangular metal guide. For simplicity and ease in structure, the

<sup>1</sup> This report is being written in support of Patent Disclosure No. 1969.

dielectric waveguide was bonded to the heat sink with conductive silver epoxy "Ablestick 71-1", cured for 10 minutes at 165°C, then for 10 minutes at 200°C. The heat sink block, with dielectric bonded on it, was bonded to the metallized alumina carrier substrate with 60-40 tin lead solder at 188°C utilizing flow solder technique. The diodes investigated were designed to oscillate at 50-60 GHz and it was appropriate to inclose the diode assembly within a standard V-band waveguide. Diode assembly inclosure and waveguide size are shown in Figure 4. A clearance hole is drilled through the V-band waveguide directly above the diode assembly for insertion of a microwave connector for contact with the anode surface of the diode (Fig. 5). The RF connector was modified by adding two discs to the positive bias; the lower disc serves as a resonant tuner, the upper disc as a choke. The first disc, nearest to the surface of the dielectric is 0.2286cm (0.090 in.) in diameter and is positioned so that when contact is made with the diode the disc will be approximately 0.0254cm (0.010 in.) above the surface of the dielectric. The second disc, slightly larger, is 0.2794cm (0.110 in.) in diameter, is positioned so that it will be approximately 0.0762cm (0.030 in.) above the first disc and is also approximately the same distance from the base of the RF connector. The entire assembly (Fig. 6) is placed in a metal box (cover) 4.2cm x 3.8cm; mounted in the V-Band waveguide to the rear, is a slide screw tuner. The front of the waveguide section is open with the dielectric pointed section protruding. The bias to the diode is fed from the top through a coaxial line.

#### DATA

Test results and parameters recorded were obtained from tests set up in the standard V-Band waveguide. Table 1 shows test results of the first GaAs Gunn diode assembled on a metal block with a 0.254cm (0.1000 in.) diameter disc attached to the anode. Table 2 gives test results of a second GaAs Gunn diode where 10 mW was obtained. Table 3 gives test results from a third GaAs Gunn diode (73-1); 7.4 mW was obtained. The diode was accidentally shorted before accurate frequency measurements could be obtained. Table 4 gives test results from a screw type GaAs Gunn diode. A photograph of the entire assembly is shown in Figure 7. In testing these oscillators, power and frequency were directly measured. The  $Q_{ext}$  or  $Q_{loaded}$  were not measured. Testing these units as self-oscillating mixers, it was determined that oscillator spectrums were sufficiently narrow to be used in this application or for transmitters and receivers.

#### DISCUSSION

In considering the most important factors in the design of this oscillator, it is first assumed that the diode has relatively small parasitics and a low negative resistance. Given these factors the following items are of concern:

a. The tuning disc on the top of the diode is the first and most important requirement. Theory<sup>2</sup> indicates that this disc is essentially an open circuited quarter-wavelength line with the diode at the input providing a low-negative resistance generator. This factor is well established and tuning discs have been used for IMPATT and Gunn diodes in metal walled cavities.

<sup>2</sup> S. Ramo, J. R. Whinnery and T. VanDuzer, "Fields and Waves in Communications Electronics", John Wiley & Sons, Inc. New York, 1967, pp. 453-457.

b. The second most important factor is that the flat metal stripes on top of the  $\text{Al}_2\text{O}_3$  (or silicon) dielectric waveguide greatly enhance coupling of power from the diode disc resonator to the dielectric waveguide.<sup>3</sup> These metal stripes are essentially transformers from the disc edges to the dielectric transmission line. The actual length of transformer stripes used was determined empirically. It is further noted that the Gunn diode can be placed outside the dielectric or in a hole cut into the dielectric line. The stripe transformers thus provide a great deal of freedom of choice.

c. The mechanical slide screw tuner is of lesser importance, and the fact that it changed the frequency very little indicates a high Q resonant circuit for the oscillator.

d. Finally the transformer stripes must be covered with a metal wall to prevent radiation. In fact, the entire structure was covered with a second metal box. It appears that any diode imbedded in a dielectric or placed near the rear side of the dielectric will radiate into space. The dimensions of these metal covers is not critical since most of the power is in the dielectric; however, covers are necessary to prevent emanating radiation for specific applications, such as local oscillators, transmitters, etc. The metal covers may not be required for beacon applications or where the oscillator is required as a separate assembly to be placed in a waveguide at the discretion of the user for his own purposes.

The design parameters used in the fabrication of the diode oscillator are preliminary and thus considerable potential for upgrading exists in this particular structure. The metal box's (cover) dimensions could be at least one-third smaller thus minimizing energy losses due to multimode reflections from the walls of the large box. The base of the dielectric should be metallized and soldered to the diode heat sink block. The transformer stripes, when the proper dimensions are established, should be metallized permanently in the dielectric, insuring good bias and low skin effect losses and presumably increasing the radiation energy into the dielectric.

#### CONCLUSIONS

Based upon test results, sufficient power was obtained for local oscillator applications. Significant achievements obtained were small size, simplicity of structure, and good output. This data clearly demonstrates the potential for designing special custom oscillators employing solid state diodes.

#### ACKNOWLEDGEMENTS

Acknowledgement is made to Mr. S. Dixon, Physicist, of the Millimeter-Wave Devices & Circuits Team, Microwave & Signal Processing Devices Division, Electronics Technology and Devices Laboratory, ERADCOM, Fort Monmouth, NJ, for self-oscillating mixer measurements and to Hughes Corporation, Torrance, CA, for the fabrication of the diode pellets.

<sup>3</sup> M.M. Chrepta and H. Jacobs, "Self-oscillating Mixers in Dielectric Waveguide," Research and Development Technical Report, ECOM-4514, August, 1977.

Table 1: Test Results GaAs Gunn Diode Assembled  
 On Metal Block With 0.2540cm (0.1000 in.)  
 Diameter Disc Attached to Anode

DIODE	OPERATION		POWER	FREQUENCY	REMARKS
	Volts	Amps	mW	GHz	
Diode assembled in metal block with 0.2540cm (0.1000 in.) diameter disc attached to Anode 72-1	2.5	2.0	1.2		
	3.5	2.0	2.5		
	3.5	2.2	2.8		
	3.4	2.0	2.9		
	3.4	2.0	2.9		
	3.4	2.0	2.9		
	3.7	2.0	3.0		
	3.4	2.0	3.0		
	3.4	1.9	3.0	50.42	
	4.0	1.8	4.2	50.48	
	3.5	1.8	4.4		Tuned with slide screw
	3.9	1.7	4.3		
	4.0	1.78	5.0	50.40	
	3.7	1.8	4.0		
	3.6	1.8	4.2		Tuned with slide screw

Table 2: Pellet Form GaAs Gunn Diode  
Assembled on Metal Block

DIODE	OPERATION		POWER	FREQUENCY	REMARKS
	Volts	Amps	mW	GHz	
73-5 Pellet Form 0.2286cm (0.090 in.) Cap	0.5	0.6			
	0.8	1.0			
	1.2	1.4			
	1.8	2.0			
	2.0	2.0			
	2.5	1.8			
	2.6	1.8	0.8		
	2.7	1.8	1.0		
	2.8	1.8	3.0		
	2.9	1.8	3.4		
	3.0	1.8	4.0		
	3.0	1.8	4.6	59.1	
	3.1	1.8	5.0	59.12	Tuned with slide screw
	3.2	1.8	5.2	59.02	
	3.2	1.8	5.4	58.92	
	3.2	1.8	6.0		Tuned with slide screw
	3.2	1.8	6.2	58.98	
	3.0	1.8	7.0		
	3.1	1.8	8.0	59.1	
	3.2	1.7	9.0	58.28	Tuned with slide screw
3.2	1.7	10			
3.3	1.8	10			

Table 3: Pellet Form GaAs Gunn Diode  
Assembled On Metal Block

DIODE	OPERATION		POWER	FREQUENCY	REMARKS
	Volts	Amps	mW	GHZ	
73-1 Pellet Form 0.2286cm (0.090 in.) Cap	0.5	0.6			
	0.6	0.9			
	0.7	1.1			
	0.9	1.2			
	1.5	1.4			
	2.0	1.6			
	2.3	1.9			
	2.5	2.0			
	2.5	1.8	4.0		
	2.7	1.8	4.4		
	2.8	1.8	4.6		
	2.8	1.8	5.0		
	2.6	1.8	5.4		Tuned with slide screw.
	2.6	1.8	5.8		
	2.6	1.8	6.0		
2.6	1.8	6.4		Tuned with slide screw.	
2.7	1.8	7.0			
2.8	1.8	7.2			
2.8	1.8	7.4			

Table 4: GaAs Gunn Diode

DIODE	OPERATION		POWER	FREQUENCY	REMARKS
	Volts	Amps	mW	GHz	
					Placed shield over transformer strips on dielectric
Microwave Assoc. Screw Type Diode No. 0411016	3.0	1.2	4.0		
	3.0	1.2	6.0		Tuned with slide screw.
Vendor's Rating VT = 1.26V IT = 1.384A Vop = 3.6V Iop = 1.061A	3.1	1.2	10.0		Increased bias voltage.
	3.1	1.2	18.0		Tuned with slide screw.
	3.2	1.2	20.0		Increased bias volt.
	2.8	1.2	15.0	47.5	Inserted B band frequency meter.
	2.8	1.2	15.0	47.5	
	2.8	1.2	15.0	47.6	
	2.8	1.2	7.4	48.0	Decreased power by tuning effect with slide screw plunger.
	2.5	1.2	7.0	47.5	Maximum tuning with decreased voltage.
	2.7	1.2	8.0	47.5	Increased bias volt.
	2.9	1.2	9.0	47.5	Increased bias volt.
	3.0	1.2	10.0	48.5	Increased bias volt.

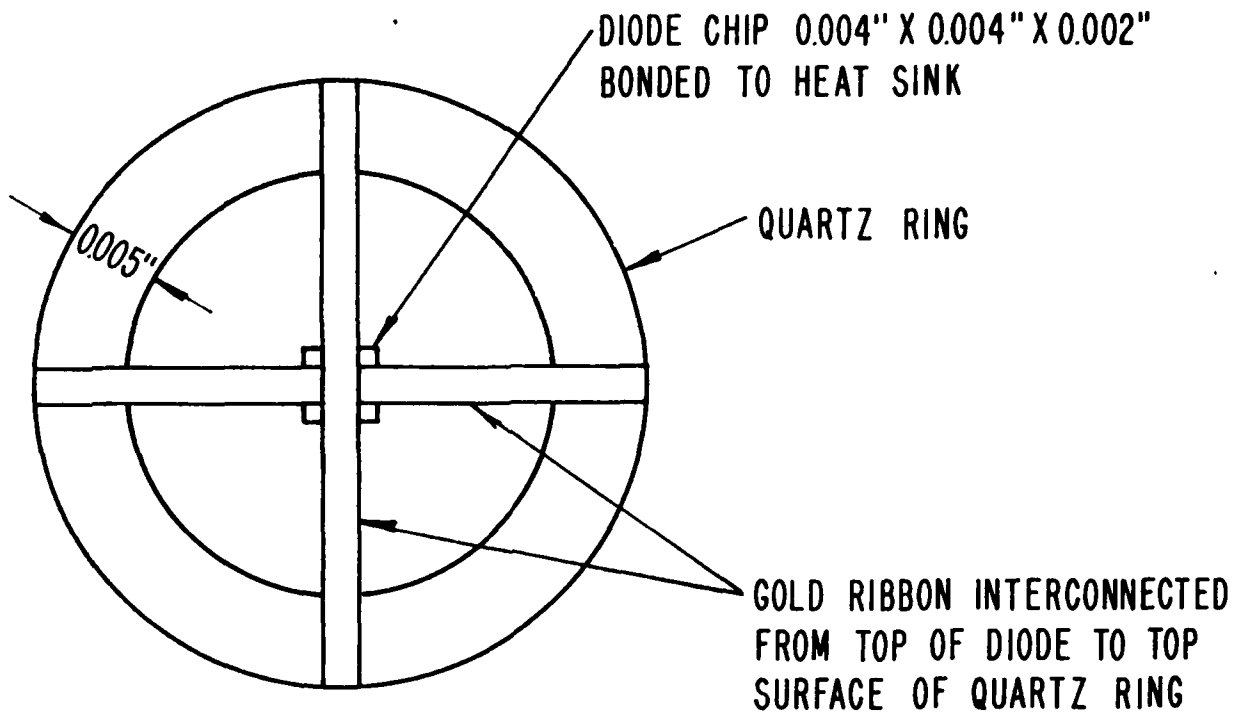

PACKAGE, TOP VIEW (WITH DIODE CAP REMOVED)

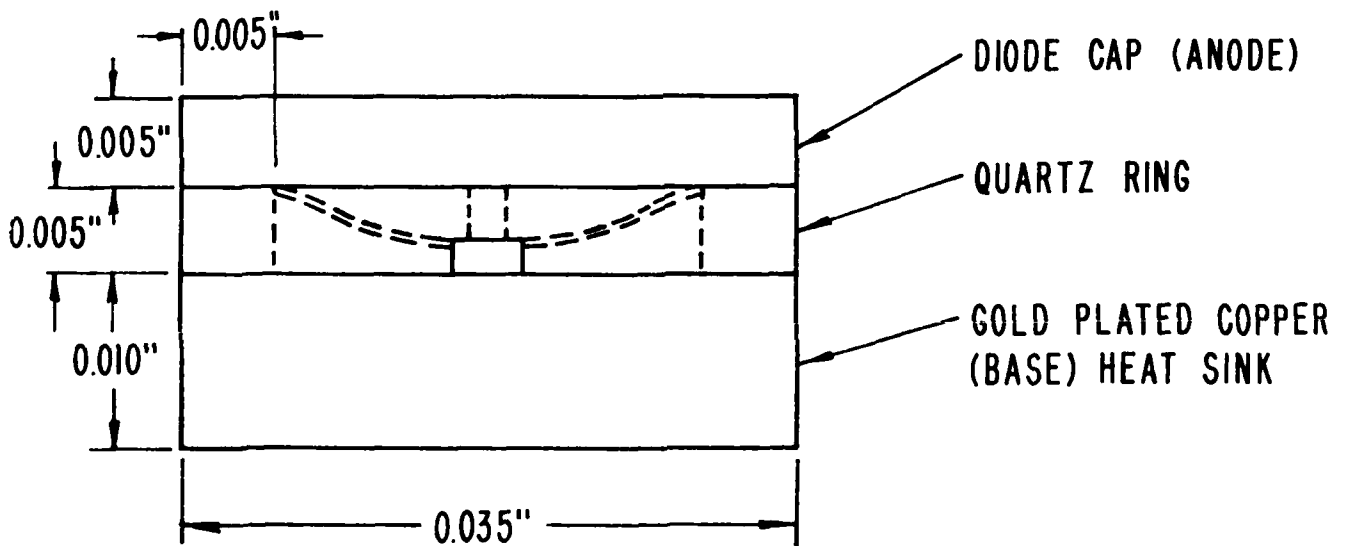

PACKAGE, SIDE VIEW (WITH DIODE CAP REMOVED)

Figure 1. Gunn Diode Packaged in Pellet Form

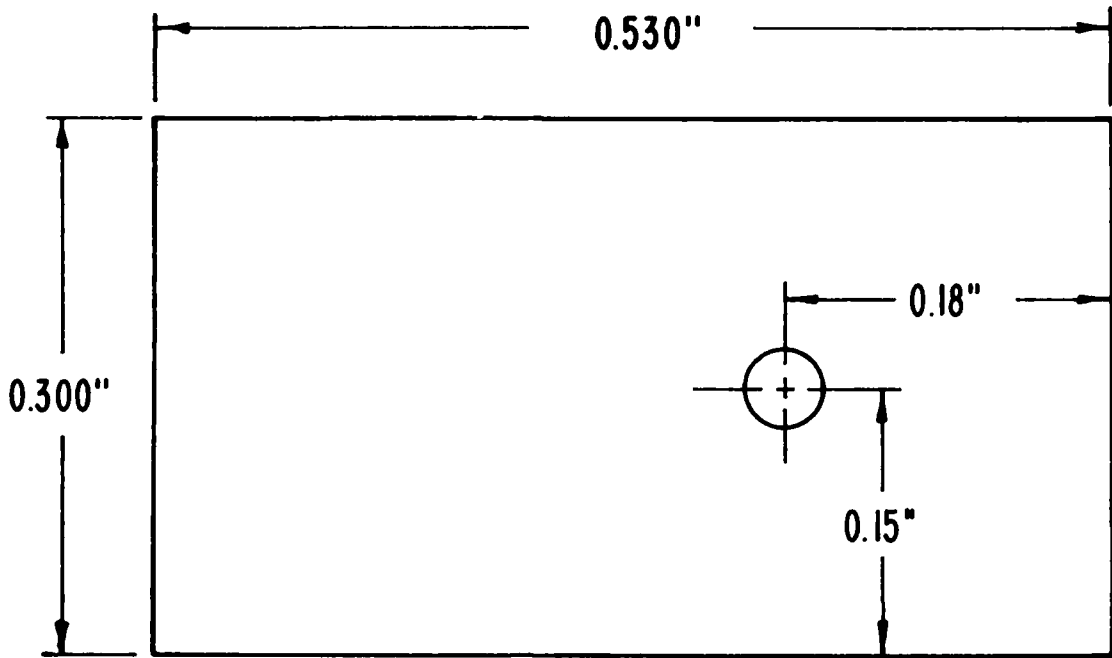

TOP VIEW

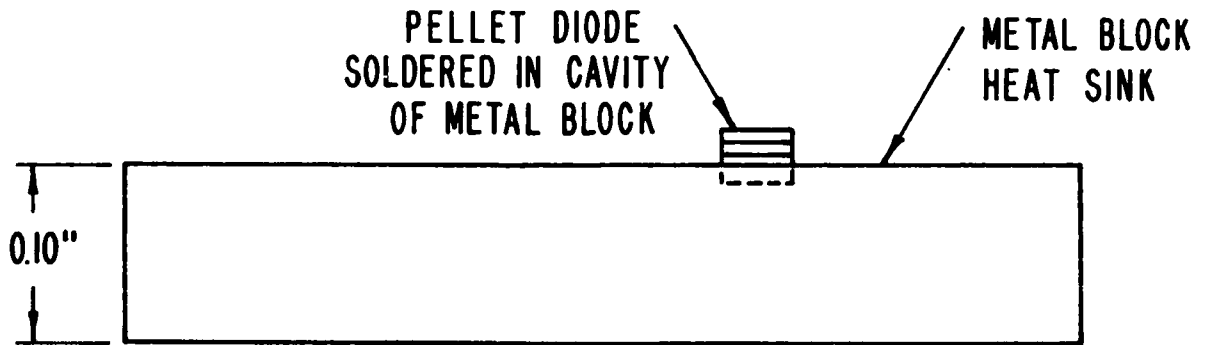

SIDE VIEW

Figure 2. Pellet Diode Soldered to Metal Block for Base Bending and Heat Sink

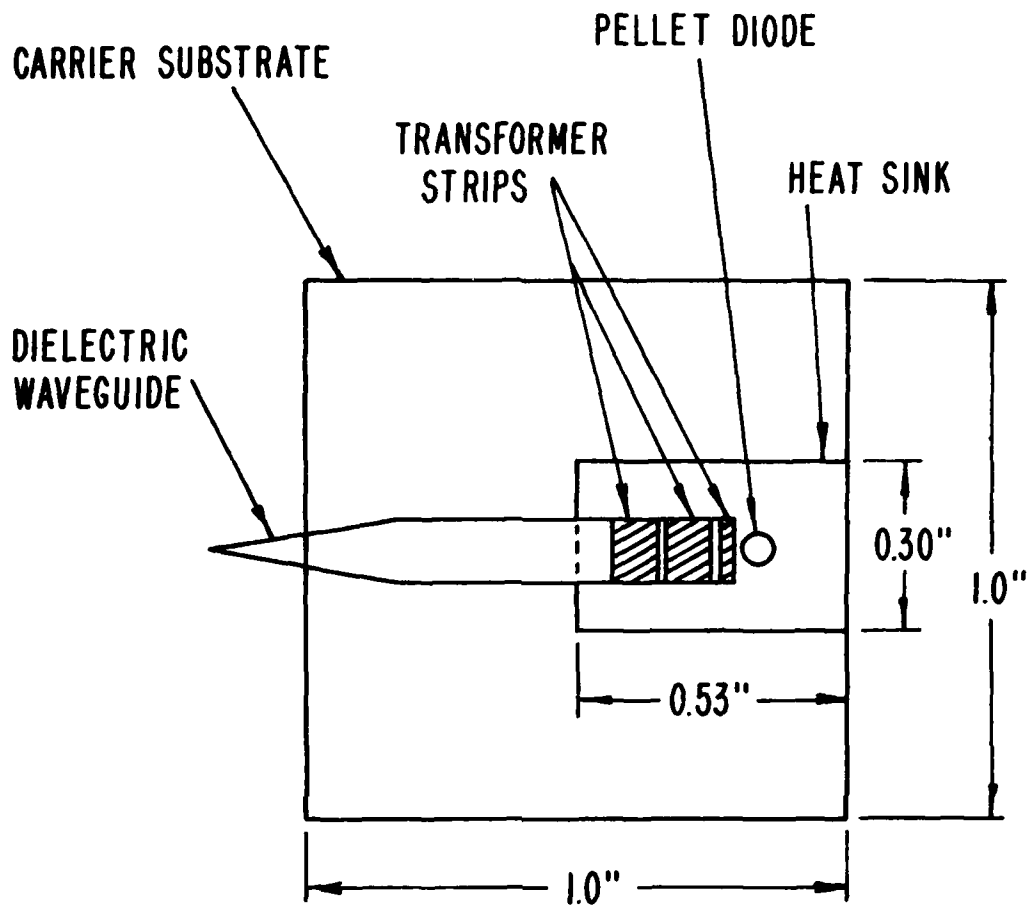

TOP VIEW

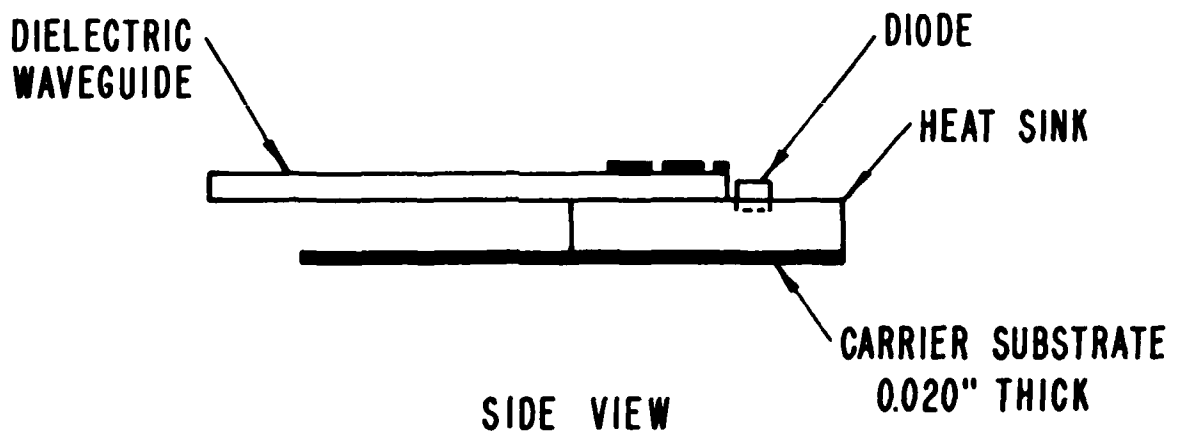

SIDE VIEW

Figure 3. Dielectric Waveguide with Transformer Strips Bonded on Heat Sink and Carrier Substrate

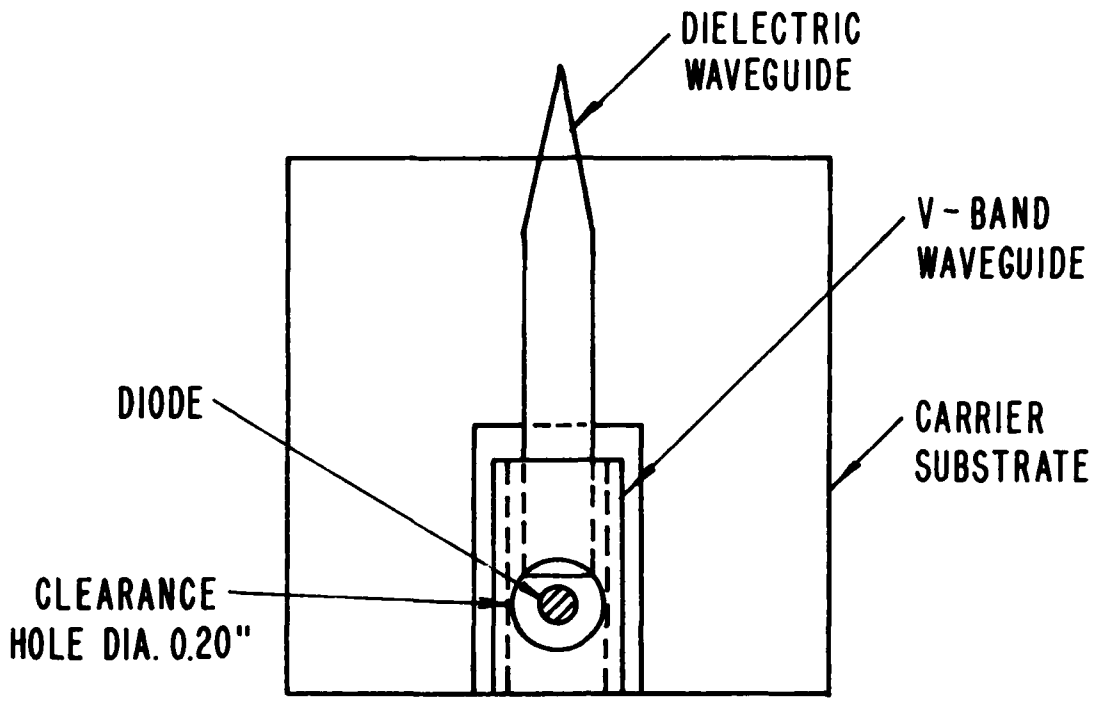

TOP VIEW

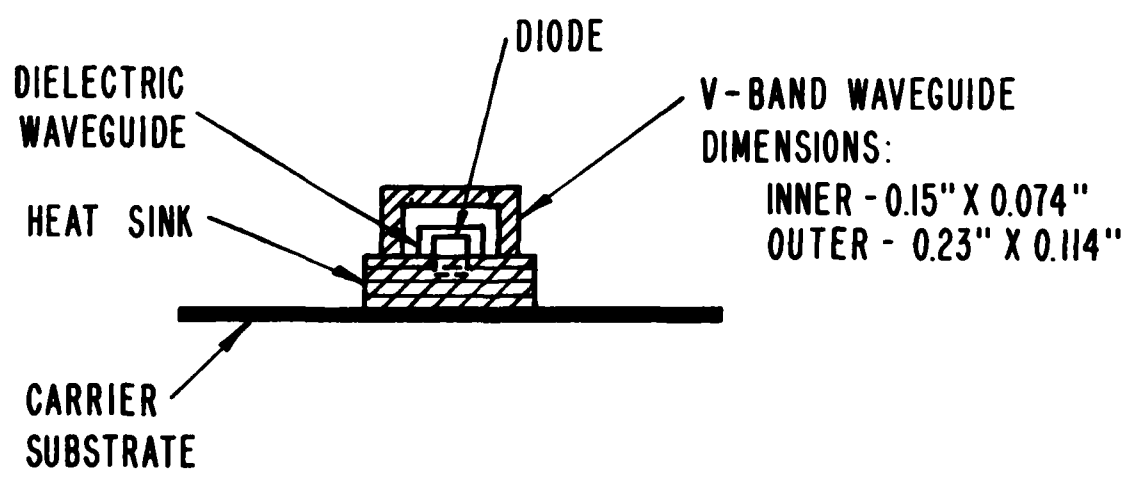

FRONT VIEW

Figure 4. Diode Assembly Inclosed Within Rectangular Waveguide

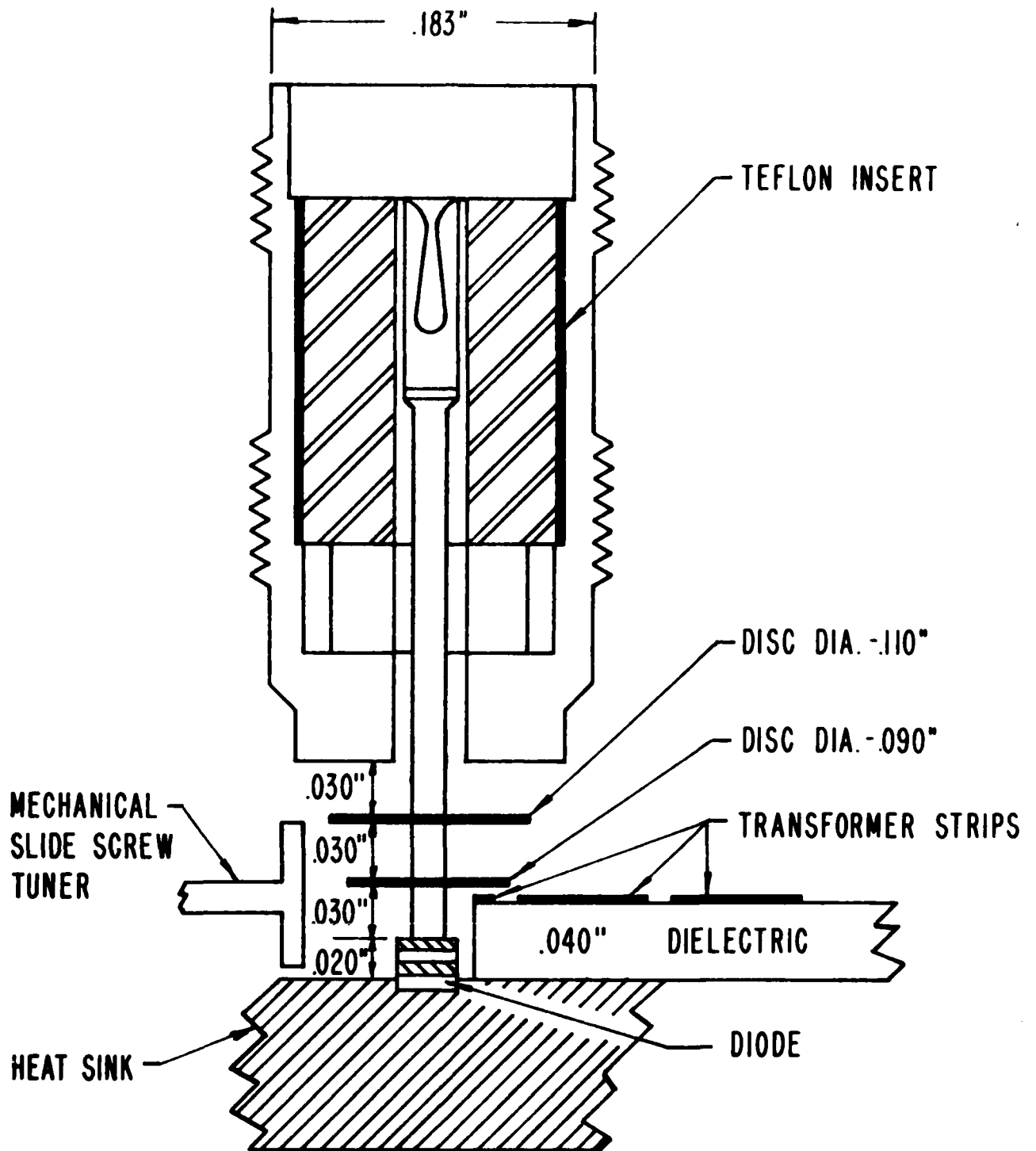
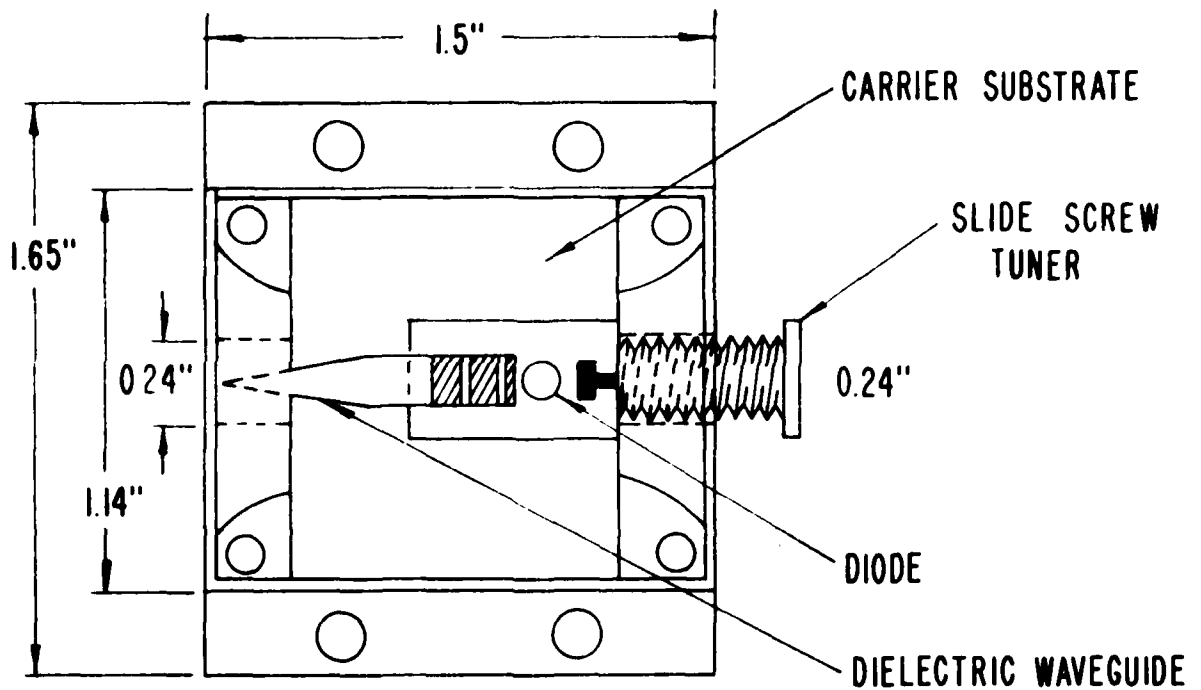
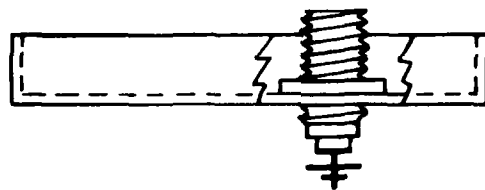

Figure 5. Modified RF Connector With Discs



TOP VIEW WITH V-BAND WAVEGUIDE REMOVED  
AND DC INPUT CONNECTOR AND COVER REMOVED



DC INPUT CONNECTOR AND COVER (SIDE VIEW)

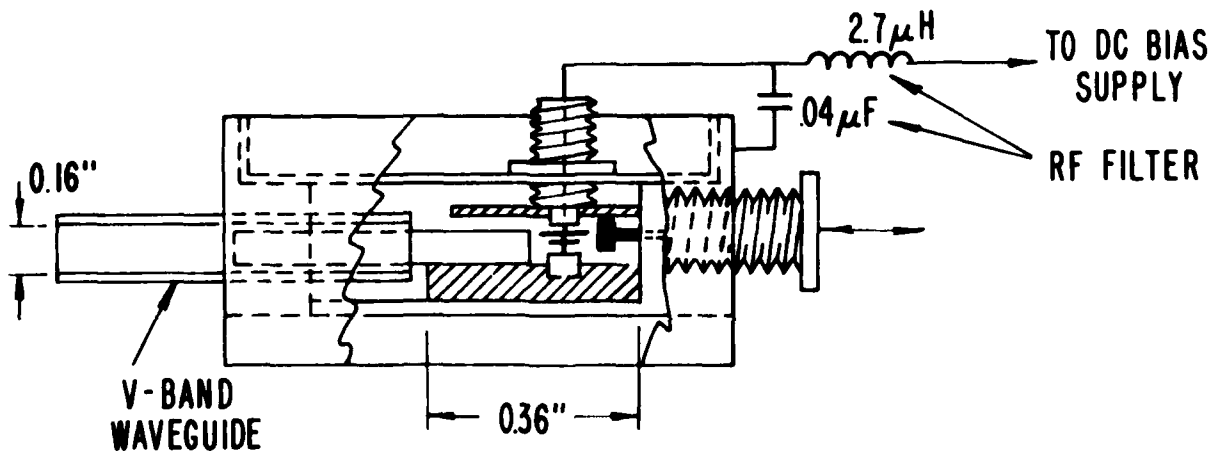

TOP VIEW WITH RF CONNECTOR AND COVER  
INSTALLED AND V-BAND WAVEGUIDE CONNECTED

Figure 6. Diode Mounted In Metal Box

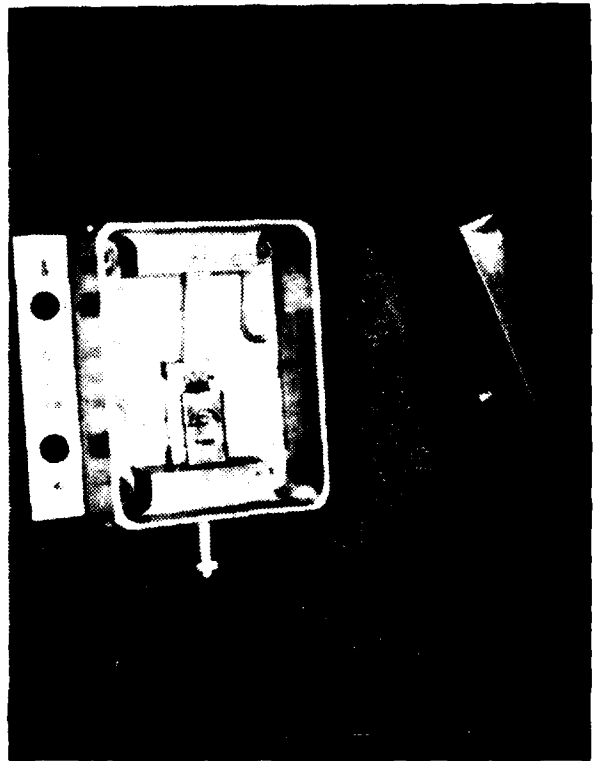
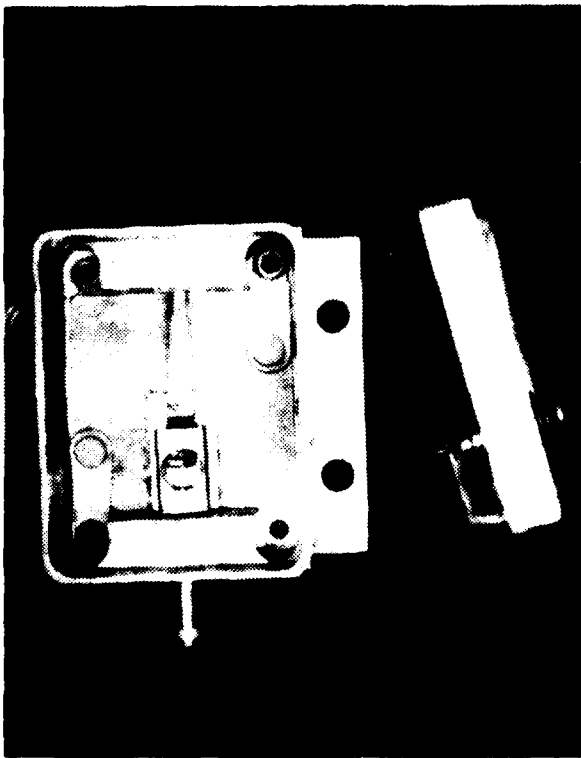

Figure 7. Gunn Oscillator Construction