

MICROCOPY RESOLUTION TEST CHART
NATIONAL BUREAU OF STANDARDS-1963-A

AEDC-TSR-80-V7

LEVEL II

2
B.S.

AD A088031



HEAT TRANSFER AND STATIC STABILITY TESTS OF THE
GENERAL PURPOSE HEAT SOURCE (GPHS) CONFIGURATIONS
AT MACH 8.0

W. A. Crosby and E. C. Knox
ARO, Inc.

January 1980

Final Report for Period 16 November - 7 December 1979

Approved for public release; distribution unlimited

DTIC
ELECTE
AUG 19 1980

A

ARNOLD ENGINEERING DEVELOPMENT CENTER
ARNOLD AIR FORCE STATION, TENNESSEE
AIR FORCE SYSTEMS COMMAND
UNITED STATES AIR FORCE

80 8 19 074

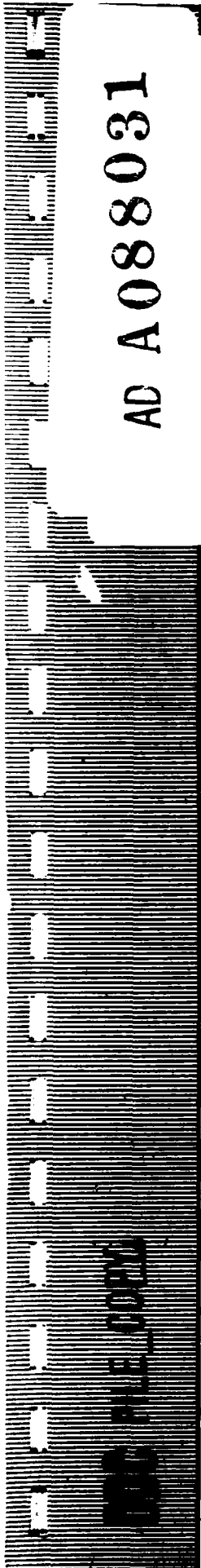

UNCLASSIFIED

REPORT DOCUMENTATION PAGE		READ INSTRUCTIONS BEFORE COMPLETING FORM
1. REPORT NUMBER AEDC-TSR-80-V71 ✓	2. GOVT ACCESSION NO. AD-A088	3. RECIPIENT'S CATALOG NUMBER 0349
4. TITLE (and Subtitle) HEAT TRANSFER AND STATIC STABILITY TESTS OF THE GENERAL PURPOSE HEAT SOURCE (GPHS) CONFIGURATIONS AT MACH 8.0.		5. TYPE OF REPORT & PERIOD COVERED Final report November 16 - December 1979
7. AUTHOR(s) W. A. Crosby and E. J. Knox, ARO, Inc., a Sverdrup Corporation Company		8. CONTRACT OR GRANT NUMBER(s)
9. PERFORMING ORGANIZATION NAME AND ADDRESS Arnold Engineering Development Center/DO Air Force Systems Command Arnold Air Force Station, TN 37389		10. PROGRAM ELEMENT, PROJECT, TASK AREA & WORK UNIT NUMBERS Program Element 921G03 Control Number 9G03-00-0
11. CONTROLLING OFFICE NAME AND ADDRESS Department of Energy Germantown, MD 20767		12. REPORT DATE Jan 1980
14. MONITORING AGENCY NAME & ADDRESS (if different from Controlling Office) General Electric Company Space Division King of Prussia, PA 19406		13. NUMBER OF PAGES 29
		15. SECURITY CLASS. (of this report) Unclassified
		15a. DECLASSIFICATION/DOWNGRADING SCHEDULE N/A
16. DISTRIBUTION STATEMENT (of this Report) Approved for public release; distribution unlimited		
17. DISTRIBUTION STATEMENT (of the abstract entered in Block 20, if different from Report)		
18. SUPPLEMENTARY NOTES Available in Defense Technical Information Center (DTIC).		
19. KEY WORDS (Continue on reverse side if necessary and identify by block number) nuclear fuel cell heat transfer static stability wind tunnel tests hypersonic flow		
20. ABSTRACT (Continue on reverse side if necessary and identify by block number) - Heat transfer and static stability tests were conducted in the VKF Tunnel B at Mach 8. Discrete point surface heat flux measurements were made on the reference (unmodified) GPHS configuration over a range of inclination angles from -50 to 140 deg at several model orientations. Six-component static force and moment measurements were made on the reference GPHS configuration and three design modifications. An angle-of-attack range of -5 to 95 deg was covered at angles of sideslip from -9 to 15 deg and aerodynamic roll angles from -45 to 45 deg.		

UNCLASSIFIED

CONTENTS

	<u>Page</u>
NOMENCLATURE	2
1.0 INTRODUCTION	6
2.0 APPARATUS	
2.1 Test Facility	6
2.2 Test Article	
2.2.1 Heat Transfer Model	7
2.2.2 Static Stability Models	7
2.3 Test Instrumentation	7
3.0 TEST DESCRIPTION	
3.1 Test Conditions and Procedures	
3.1.1 General	8
3.1.2 Data Acquisition	9
3.2 Data Reduction	
3.2.1 Heat Transfer Phase	9
3.2.2 Static Stability Phase	9
3.3 Uncertainty of Measurements	11
4.0 DATA PACKAGE PRESENTATION	11

APPENDIXES

I. ILLUSTRATIONS

Figure

1. Tunnel B	13
2. Installation Photographs	14
3. Sketch of Model Orientations	16
4. Force Model Details	17
5. Windshield with Pressure Tube Location	18
6. Force Phase Installation Sketch	19
7. Gage Locations	20

II. TABLES

Table

1. Estimated Uncertainties	22
2. Test Summary	24

III. SAMPLE TABULATED DATA

1. Sample Tabulated Heat Transfer Data	27
2. Sample Tabulated Static Force and Moment Data	28

NOMENCLATURE

A	Reference area, 57.906 in. ²
AB	Base area (face-on = 55.501 in. ² , side-on = 31.168 in. ²)
ACAV	Cavity area, 2.405 in. ²
ALPHA	Angle of attack, deg
ALPI	Indicated sector pitch angle, deg
ALPP	Total angle of attack, missile axes, deg
ALPPB	Prebend angle, deg
BETP	Sideslip angle, body axes, deg
C1	Thermopile Gardon gage calibration factor measured at 530°R, Btu/ft ² -sec/MV
C2	Temperature corrected thermopile Gardon gage calibration factor, Btu/ft ² -sec/MV (see Eq. 1)
CA	Forebody axial-force coefficient, body axes, CAT-CAB-CACAV (applicable when ALPHA < 45 deg)
CAB	Base axial-force coefficient, body axes, -AB(PB-P)/Q · A
CACAV	Cavity axial force coefficient, body axes, -ACAV(PCAV-P)/Q · A
CAP	Forebody axial-force coefficient, missile axes
CAT	Total axial-force coefficient, body axes, total axial force/Q · A
CLL	Rolling-moment coefficient, body axes, rolling moment/Q · A · L
CLLP	Rolling-moment coefficient, missile axes
CLM	Pitching-moment coefficient, body axes, pitching moment/Q · A · L
CLMP	Pitching-moment coefficient, missile axes
CLN	Yawing-moment coefficient, body axes, yawing moment/Q · A · L
CLNP	Yawing-moment coefficient, missile axes
CN	Normal-force coefficient, body axes, CNT-CAB-CACAV (applicable when ALPHA ≥ 45 deg)
CNP	Normal-force coefficient, missile axes

CNT	Total normal force coefficient, body axes, total normal force/ $Q \cdot A$
CODE	Number used to designate model-to-balance orientation
CONFIG	Model configuration designation. Designates model orientations for heat transfer phase (see Fig. 3)
CY	Side-force coefficient, body axes, side force/ $Q \cdot A$
CYP	Side-force coefficient, missile axes
E	Thermopile Gardon gage output, mv
GAGE	Thermopile Gardon gage identification number
H(REF)	Reference heat-transfer coefficient (Fay-Riddell) on a hemisphere of radius R, $\text{Btu/ft}^2\text{-sec-}^\circ\text{R}$
H(TT)	Heat-transfer coefficient based on QDOT and TT, $\text{QDOT}/(\text{TT}-\text{TW})$, $\text{Btu/ft}^2\text{-sec-}^\circ\text{R}$
KG	Thermopile Gardon gage temperature calibration factor, $^\circ\text{R}/\text{mv}$
L	Reference length, 4.302 in.
M	Free-stream Mach number
NCP	Normal-force center-of-pressure location, body axes, inches from model moment reference point ($\text{CLM} \cdot \text{L}/\text{CN}$)
NCPP	Normal-force center-of-pressure location, missile axes, inches from model moment reference point ($\text{CLMP} \cdot \text{L}/\text{CNP}$)
P	Free-stream static pressure, psia
PB	Base pressure, psia
PCAV	Cavity pressure, psia
PHI	Roll angle, deg
PHII	Indicated roll angle, deg
PHIP	Aerodynamic roll angle, deg
PN	Data point number

PT	Tunnel stilling chamber pressure, psia
Q	Free-stream dynamic pressure, psia
QDOT	Measured heat flux, Btu/ft ² -sec
R	Effective hemisphere radius, ft
RE	Free-stream unit Reynolds number, ft ⁻¹
RHO	Free-stream density, lbm/ft ³
RUN	Data set identification number
S	Surface distance from reference point used in plotting data, in.
ST(TT)	Stanton number based on TT $H(TT)/(RHO)(V) [0.2235 + 1.35 \times 10^{-5}(TT + TW)]$
T	Free-stream static temperature, °R
TGE, TEDGE	Thermopile Gardon gage edge temperature, °R
THETA	Angular measurement of gage locations, deg (see Fig. 7)
TT	Tunnel stilling chamber temperature, °R
TW, TGAGE	Model surface temperature, °R
x, y	Linear measurements of gage locations, in. (see Fig. 7)
V	Free-stream velocity, ft/sec
YCP	Side-force center-of-pressure location, body axes, inches from model moment reference point (CLN · L/CY)
YCPP	Side-force center-of-pressure location, missile axes, inches from model moment reference point (CLNP · L/CYP)
ΔT	Temperature difference from the Gardon gage center to its edge, °R

MODEL CONFIGURATION NOMENCLATURE

CONFIGURATION

DESCRIPTION

A	LM/RB (Low Mass/Revision B) reference sharp corner
B	Round edge chamfer
C	39° edge chamfer
D	45° corner chamfer

1.0 INTRODUCTION

The work reported herein was conducted by the Arnold Engineering Development Center (AEDC), Air Force Systems Command (AFSC), under Program Element 921G03, Control Number 9G03-00-0, at the request of the Department of Energy (DOE) for the General Electric Company (GE). The DOE project monitor was Mr. Robert Morrow and the GE project monitor was Mr. Lewis Feldman. The results were obtained by ARO, Inc., AEDC Division (a Sverdrup Corporation Company), operating contractor for the AEDC, AFSC, Arnold Air Force Station, Tennessee. The test was conducted in the von Karman Gas Dynamics Facility (VKF), Tunnel B, during the period 16 November - 7 December 1979, under ARO Project No. V41B-B9.

The primary objectives of the tests were to obtain heat transfer measurements and static stability data on the General Purpose Heat Source (GPHS) nuclear fuel cell. The heat transfer results will be used to verify heating correlations currently used in reentry analyses. Aerodynamic data are to be used in 6DOF simulation studies to demonstrate GPHS stability characteristics and to determine effective design modifications. As a power source for satellite applications, the GPHS will be designed to survive accidental earth reentry and terminal impact.

Heat transfer measurements were obtained on the reference sharp corner GPHS design at angles of attack from -50 to 140 deg at Mach 8. A wide range of model attitudes were covered simulating a tumbling reentry from which average heat inputs to each surface could be inferred. In addition, oil flow photographs and shadowgraph movies were obtained at selected model attitudes.

Static stability, axial force, and base pressure data were also obtained at Mach 8. An angle of attack range from -5 to 95 deg at sideslip angles of -9 to 15 deg and aerodynamic roll angles from -45 to 45 deg was obtained. Model flow-field shadowgraphs were obtained on all configurations at selected model attitudes.

Inquiries to obtain copies of the test data should be directed to the Department of Energy, Germantown, MD 20767. A microfilm record has been retained in the VKF at AEDC.

2.0 APPARATUS

2.1 TEST FACILITY

Tunnel B (Fig. 1) is a closed circuit hypersonic wind tunnel with a 50-in. diam test section. Two axisymmetric contoured nozzles are available to provide Mach numbers of 6 and 8 and the tunnel may be operated continuously over a range of pressure levels from 20 to 300 psia at Mach number 6, and 50 to 900 psia at Mach number 8, with air supplied by the VKF main compressor plant. Stagnation temperatures sufficient to avoid air liquefaction in the test section (up to 1350°R) are obtained through the use of a natural-gas-fired combustion heater. The entire tunnel (throat,

nozzle, test section, and diffuser) is cooled by integral, external water jackets. The tunnel is equipped with a model injection system, which allows removal of the model from the test section while the tunnel remains in operation. A description of the tunnel may be found in the Test Facilities Handbook*.

2.2 TEST ARTICLE

2.2.1 Heat-Transfer Model

The test article was a twice-scale model of the actual GPHS. A photograph of the model installed in the test section is presented in Fig. 2a. The model material was 304 stainless steel. Four of the model's six sides were instrumented and two sides were used for sting attachment. The material thickness on each side was 0.375-in.

A knuckle-jointed sting which could be rotated in 20-deg increments was used with the model to provide a 130-deg angle of attack variation over the primary instrumented surfaces (2 and 5). A sketch of the model in the four different orientations tested is shown in Fig. 3. Overall model dimensions are also shown in this figure.

2.2.2 Static Stability Models

Four twice-scale configurations of the GPHS were tested. These included the LM/RB reference sharp corner model and three proposed design modifications consisting of straight- and round-edge chamfers and a corner chamfer (see Fig. 4). All model components were fabricated of 304 stainless steel. Two models of each configuration were provided to facilitate both face-on and side-on sting attachment. An angle of attack range up to 95 deg was achieved by using the two attachment methods along with two sting prebend angles (ALPPB = 3 and 30 deg). Model roll angles were typically accomplished by rotating the model on the balance. Roll angles from -90 to 180 deg in 45 deg increments were obtained in this manner. Other roll angles were obtained by sector roll. Due to a partially external balance mounting, a windshield of 1.75 in. OD 304 stainless steel tubing was designed and manufactured by VKF (see Fig. 5) to isolate the balance from the tunnel flow. An installation sketch depicting both prebend installations is given in Figure 6. A photograph of the low prebend installation is presented in Fig. 2b.

2.3 TEST INSTRUMENTATION

The measuring devices, recording devices, and calibration methods used for all measured parameters are listed in Table 1 along with the estimated measurement uncertainties. Heat-transfer rate measurements were obtained using thermopile Gardon-type gages that were manufactured and calibrated by the VKF. The thermopile gage utilizes vapor-deposited

*Test Facilities Handbook (Eleventh Edition). "von Karman Gas Dynamics Facility Vol. 3." Arnold Engineering Development Center, June 1979.

layers of antimony and bismuth to form a thermopile on the back surface of a thin sensing foil. The gage diameter was 0.125-in. and the foil thickness was 0.005-in. A total of 45 thermopile gages were used in the heat-transfer model; gage locations are illustrated in Fig. 7.

Two additional heat-transfer measurement devices were installed for check-out of the gage design. These gages were the Schmidt-Bouelster type* (see Reference below for detailed description). The diameter of these gages was 0.1875-in. and their locations are also shown in Fig. 7.

Oil flow photographs were taken at selected model attitudes with a Varitron Model E 70mm camera mounted on the top window of the test section. An automatic camera control system was used to provide shutter sequencing in 4-sec intervals.

3.0 TEST DESCRIPTION

3.1 TEST CONDITIONS AND PROCEDURES

3.1.1 General

The nominal test condition is given below.

<u>M</u>	<u>PT, psia</u>	<u>TT, °R</u>	<u>Q, psia</u>	<u>P, psia</u>	<u>RE x 10⁻⁶/ft</u>
8.0	275	1260	1.3	0.028	1.3

A test summary showing all configurations tested and the variables for each is presented in Table 2.

In the VKF continuous flow wind tunnels (A, B, C), the model is mounted on a sting support mechanism in an installation tank directly underneath the tunnel test section. The tank is separated from the tunnel by a pair of fairing doors and a safety door. When closed, the fairing doors, except for a slot for the pitch sector, cover the opening to the tank and the safety door seals the tunnel from the tank area. After the model is prepared for a data run, the personnel access door to the installation tank is closed, the tank is vented to the tunnel flow, the safety and fairing doors are opened, and the model is injected into the airstream, and the fairing doors are closed. After the data are obtained, the model is retracted into the tank and the sequence is reversed with the tank being vented to atmosphere to allow access to the model in preparation for the next run. The sequence is repeated for each configuration change.

Model attitude positioning and data recording were accomplished with the point-pause and sweep modes of operation, using the VKF Model Attitude Control System (MACS). Model pitch and yaw requirements were entered into the controlling computer prior to the test. Model positioning and data recording operations were performed automatically during the test by selecting the list of desired model attitudes and initiating the system.

*Carhanan, K. R., Hartman, G. J., and Neuner, G. J. "Development of TPS Flight Test and Operational Instrumentation," Aerotherm Final Report. FR-75-135, NASA Contract NA59-13543, January 1975.

3.1.2 Data Acquisition

For the heat-transfer test phase, the outputs from the 47 gages and their edge temperatures were recorded on a Beckman 210 analog-to-digital converter with each channel being sampled approximately every 0.068 sec. Prior to each test run, the thermocouples were monitored to ascertain that the model temperature was uniform within ± 5 deg. The model was then injected at the desired test attitude, taking about 2.5 sec to reach the tunnel centerline. Shortly before liftoff a single loop of data was taken, and after liftoff data were recorded continuously with a period of 0.068 sec. The model remained at the centerline position for about 2 sec. Upon retraction data recording ceased. After each test run the model was cooled and prepared for a subsequent injection.

Static stability data were recorded in either the point-pause or sweep mode of operation, using the MACS. The mode for each data group is identified in the test summary (Table 2).

The point-pause data were obtained for finite values of ALPHA and PHI with a delay before each data point to allow the base pressures to stabilize. Model roll angles were adjusted manually in 45 deg increments. Each data point for this mode of operation represents the resultant of a Kaiser-Bessel digital filter utilizing 16 samples taken over a time span of 0.33 sec.

The continuous sweep data were obtained for a fixed value of PHI with a sweep (ALPHA) rate of 1.0 deg/sec. A data sample was recorded every 0.0208 sec and 16 samples were applied to a Kaiser-Bessel digital filter to produce a data point every 0.31 deg in pitch. The data were then interpolated to obtain the data at the requested model attitudes. The base pressures were obtained using a curve fit of data obtained during the point-pause mode to calculate the base and cavity axial-force coefficients.

3.2 DATA REDUCTION

3.2.1 Heat Transfer Phase

The thermopile Gardon-type gages used in the model are direct reading heat-flux transducers whose output is converted to heat flux by a scale factor. The scale factor has some temperature dependency and is corrected for the gage-edge temperature by the equation

$$\begin{aligned} C2 = & C1 [4.72878 - (2.83765 \times 10^{-2})(TGE) \\ & + (7.82707 \times 10^{-5})(TGE)^2 - (9.44869 \times 10^{-8})(TGE)^3 \\ & + (4.30151 \times 10^{-11})(TGE)^4] \end{aligned} \quad (1)$$

The gage heat flux is then computed by the equation

$$QDOT = C2(E) \quad (2)$$

The gage wall temperature used in computing the gage heat transfer coefficient is obtained from two parts - the output of the gage edge thermocouple and the temperature difference from the gage center to its edge, which is proportional to the gage output, E. The latter temperature differences are computed by the equation

$$\Delta T = KG(E) \quad (3)$$

and the gage edge temperature, TGE, was computed using NBS Tables for Fe-Cn thermocouples. The gage wall temperature is then computed as

$$TW = TGE + 0.75(\Delta T) \quad (4)$$

The 0.75 factor represents an average, or integrated, value across the gage.

The gage output (E) used in Eq. (2) is an average of five consecutive samples of the gage output, commencing with the data loop recorded at least one second after the model arrived on centerline. The average output was compared to that for each of the five data loops used in the average and if any of the separate values differed from the average by ± 2 percent or ± 15 counts, whichever is larger, an asterisk (*) was printed by the computed values for that gage. This procedure has been adopted to designate "wild" points that occur from noise spikes, etc. There were no occurrences of this type in the data for this test. The gage-edge temperature was averaged in the same manner with ± 5 deg allowable deviation from the average.

The gage heat-transfer coefficient was computed using the equation

$$H(TT) = \frac{QDOT}{(TT-TW)} \quad (5)$$

and the gage Stanton number by the equation

$$ST(TT) = \frac{H(TT)}{(\text{RHO})(V)} [0.2235 + 1.35 \times 10^{-5}(TT + TW)]^{-1} \quad (6)$$

3.2.2 Static Stability Phase

The static force data were obtained utilizing the data acquisition procedures as described in Section 3.1. The force and moment measurements were reduced to coefficient form using the digitally filtered data points and correcting for first and second order balance interaction effects. The coefficients were also corrected for model tare weight and balance-sting deflections. Model attitude and tunnel stilling chamber pressure were also calculated from digitally filtered values.

Aerodynamic force and moment coefficients are presented in the body and nonrolling body (missile) axis systems. For the missile axis system the normal-force direction is always in the pitch plane of the tunnel and normal to the longitudinal axis of the model. Pitching- and yawing-moment coefficients are referenced to the geometric center of the LM/RB reference configuration. Model thickness (4.302 in.) and broad face area (57.906 in.²) were used as the reference length and area for the missile aerodynamic coefficients.

3.3 UNCERTAINTY OF MEASUREMENTS

In general, instrumentation calibrations and data uncertainty estimates were made using methods recognized by the National Bureau of Standards (NBS)*. Measurement uncertainty is a combination of bias and precision errors defined as:

$$U = \pm (B + t_{95}S)$$

where B is the bias limit, S is the sample standard deviation, and t_{95} is the 95th percentile point for the two-tailed Student's "t" distribution, (95-percent confidence interval) which for sample sizes greater than 30 is taken equal to 2.

Estimates of the measured data uncertainties for this test are given in Table 1a. With the exception of the force and moment balance, data uncertainties are determined from in-place calibrations through the data recording system and data reduction program. Static load hangings on the balance simulated the range of loads and center-of-pressure locations anticipated during the test, and measurement errors are based on differences between applied loads and corresponding values calculated from the balance equations used in the data reduction. Load hangings to verify the balance calibration are made in-place on the assembled model.

Propagation of the bias and precision errors of measured data through the calculated data was made in accordance with the reference* below and the results are given in Table 1b.

4.0 DATA PACKAGE PRESENTATION

Tabulated results and plotted data were furnished to DOE and GE in a data package. For convenience, results from the heat and force test phases were bound in separate volumes. Samples of the tabulated data from both phases are presented in Appendix III.

The tabulated static force and moment data are given in the body and nonrolling body axis systems. Correction to CAT for Runs 1 through 3 and correction to CNT for Runs 4 through 8 was required due to possible amplifier gain drift of the axial force component. CAT and CNT were both measured by the axial force gage for the given runs because of face-on and side-on model attachment. The correction consisted of shifting data points of the runs involved by a constant based on the level of CAT on Run 22, a repeat of Run 1.

A complete set of equations used to calculate model attitudes and static force and moment coefficients in the nonrolling body axes are provided in the Data Package.

*Abernethy, R. B. et al. and Thompson, J. W. "Handbook Uncertainty in Gas Turbine Measurements." AEDC-TR-73-5 (AD 755356), February 1973.

I

APPENDIX I

ILLUSTRATIONS

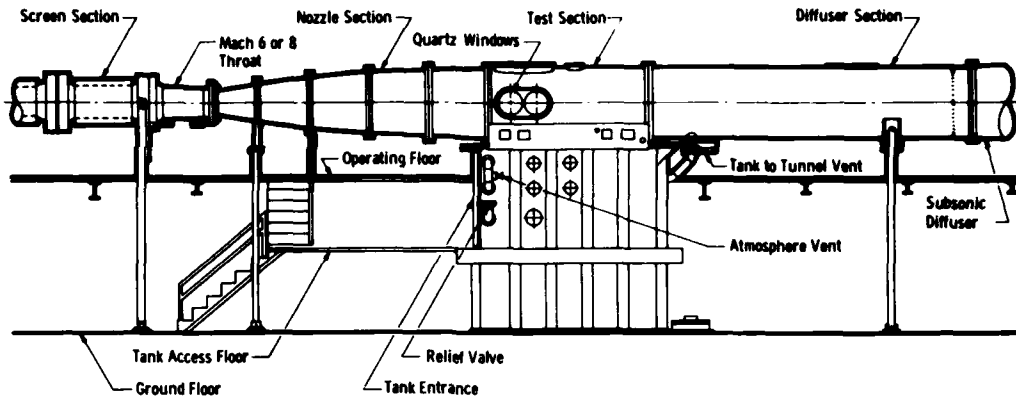

a. Tunnel assembly

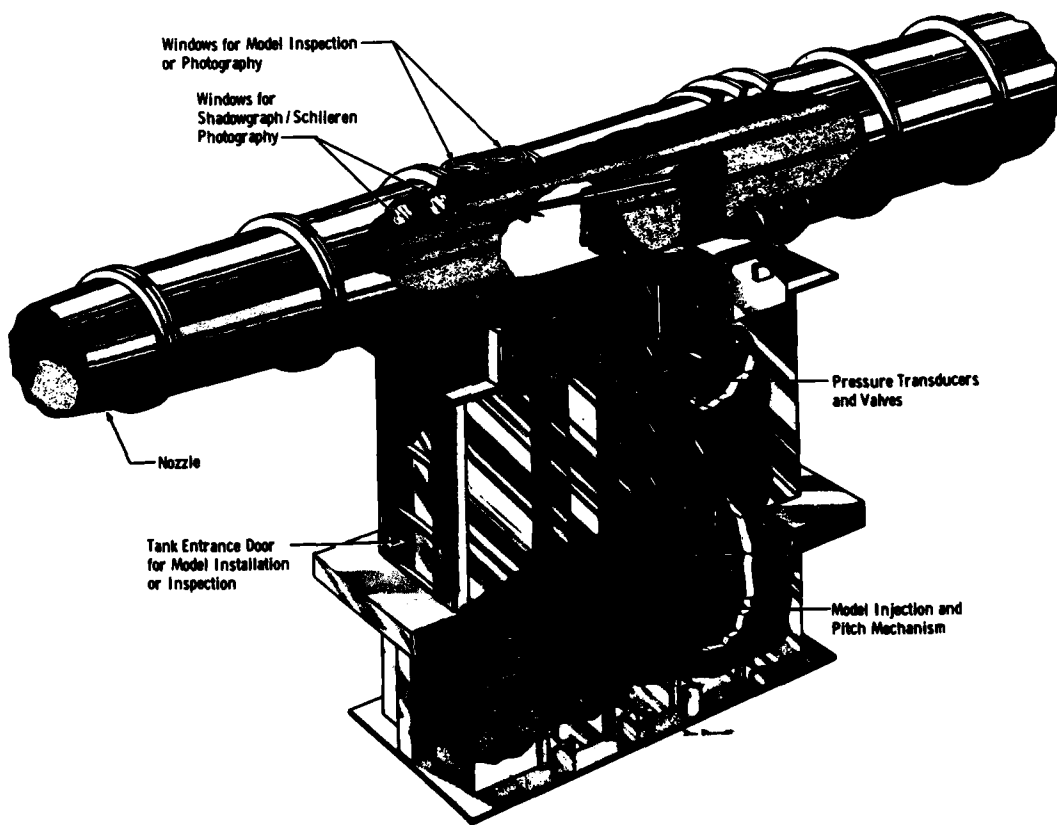

b. Tunnel test section
Fig. 1. Tunnel B

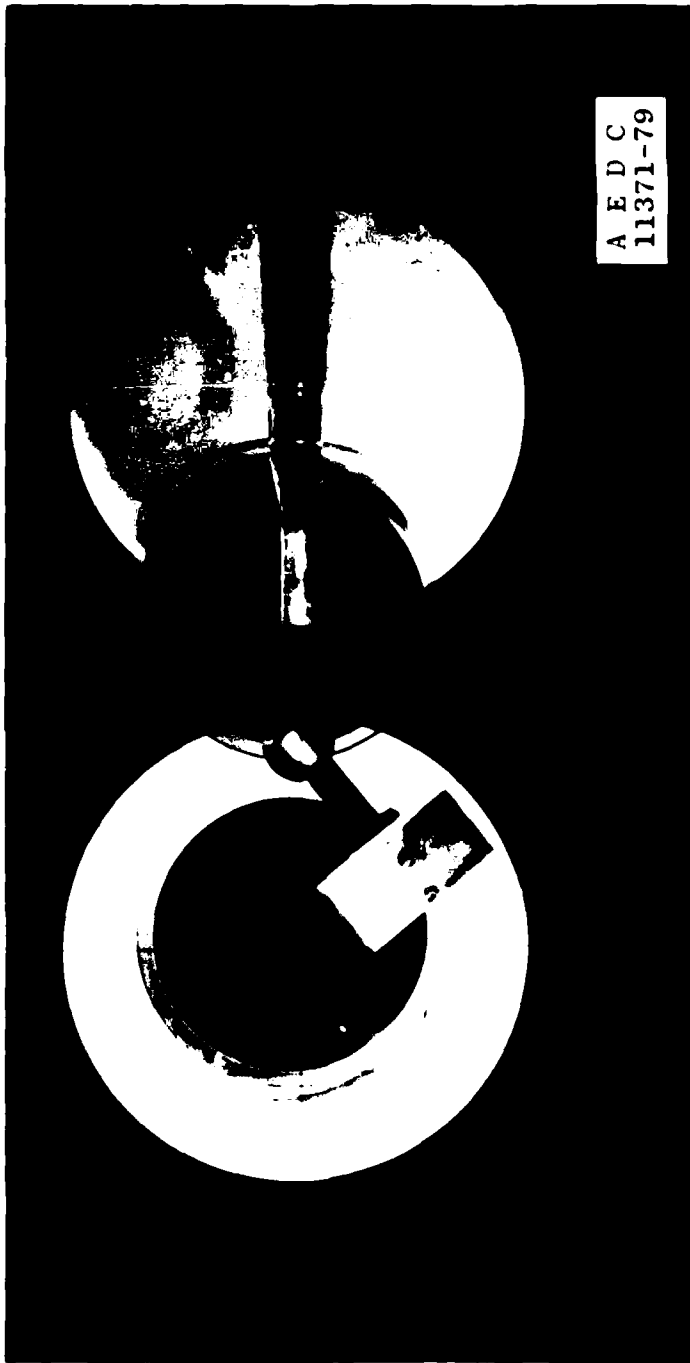

a. Heat-transfer phase
Figure 2. Installation. Photographs



b. Force phase
Figure 2. Concluded

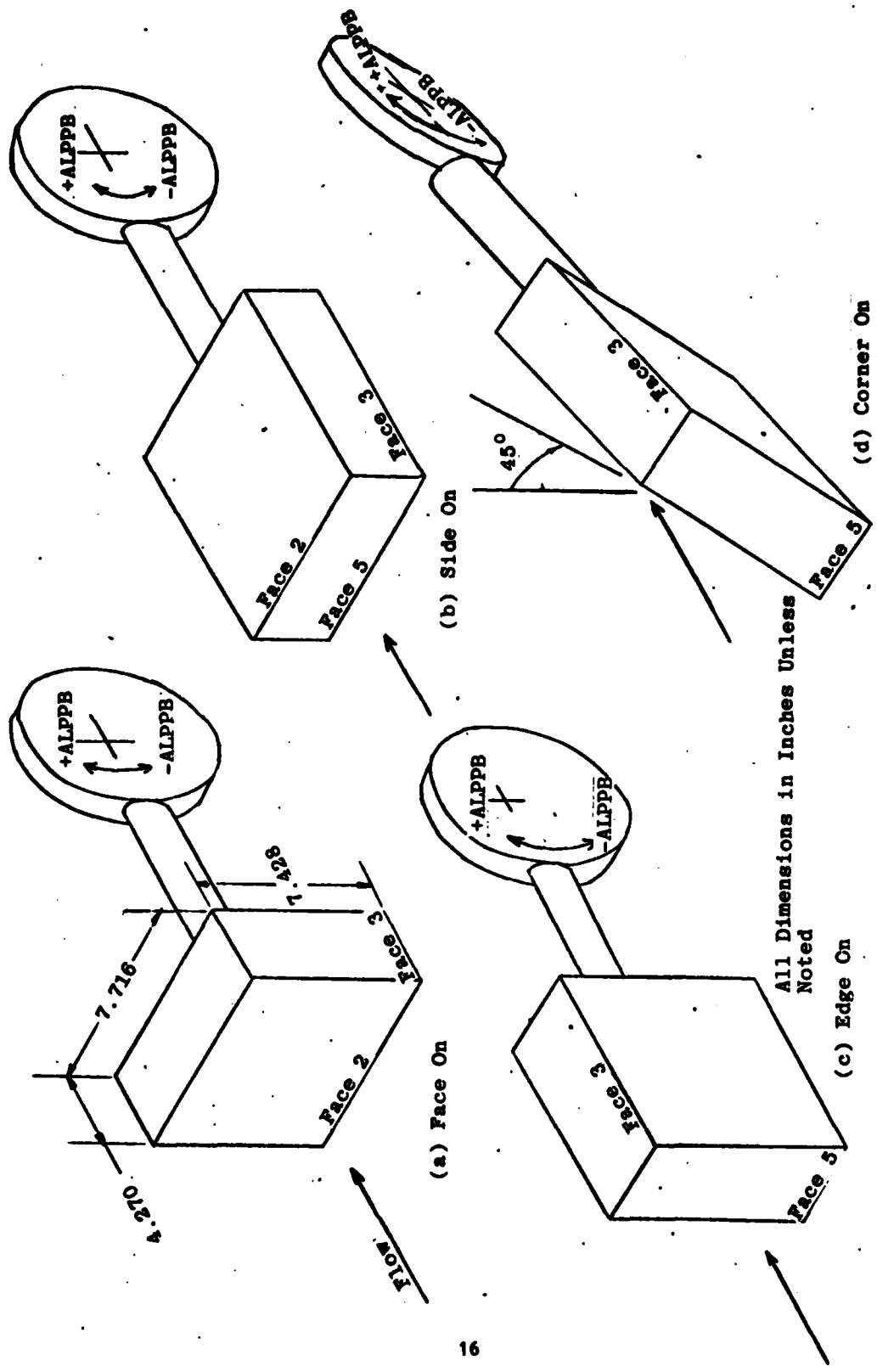
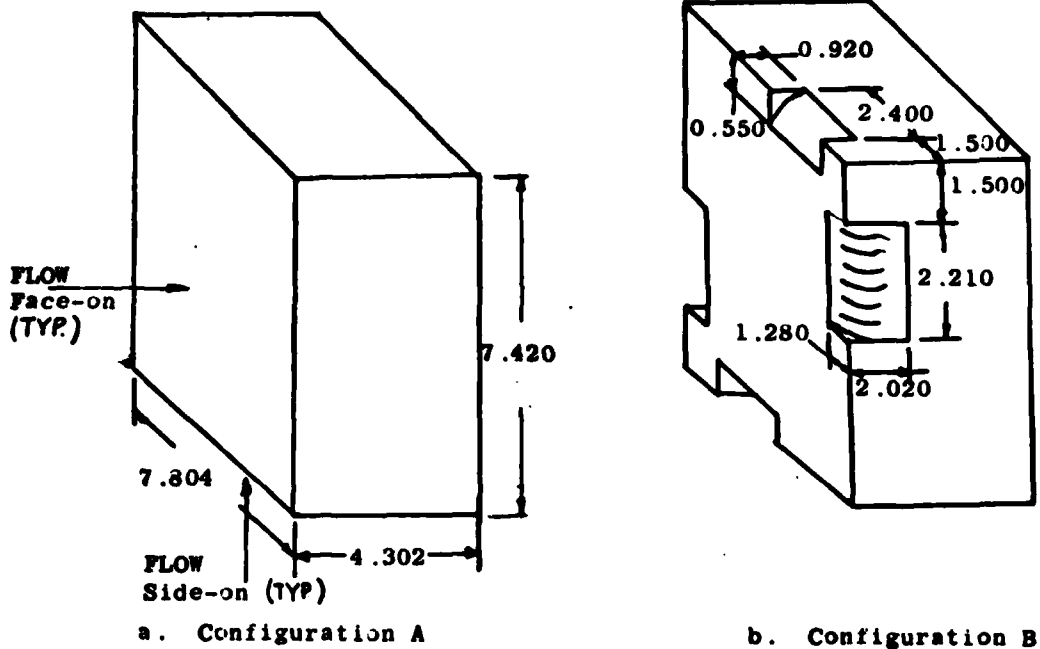

Figure 3. Sketch of Model Orientations

- Notes: 1. Models Shown at Roll Angle = 0.0 deg
 2. Cut-outs on opposite faces are identical.



All dimensions given are typical.
 All dimensions in inches.

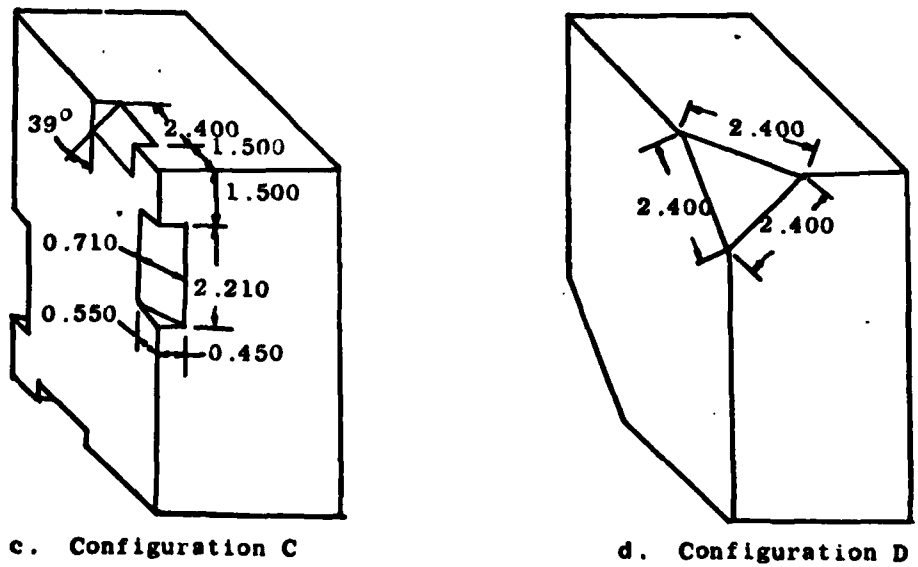
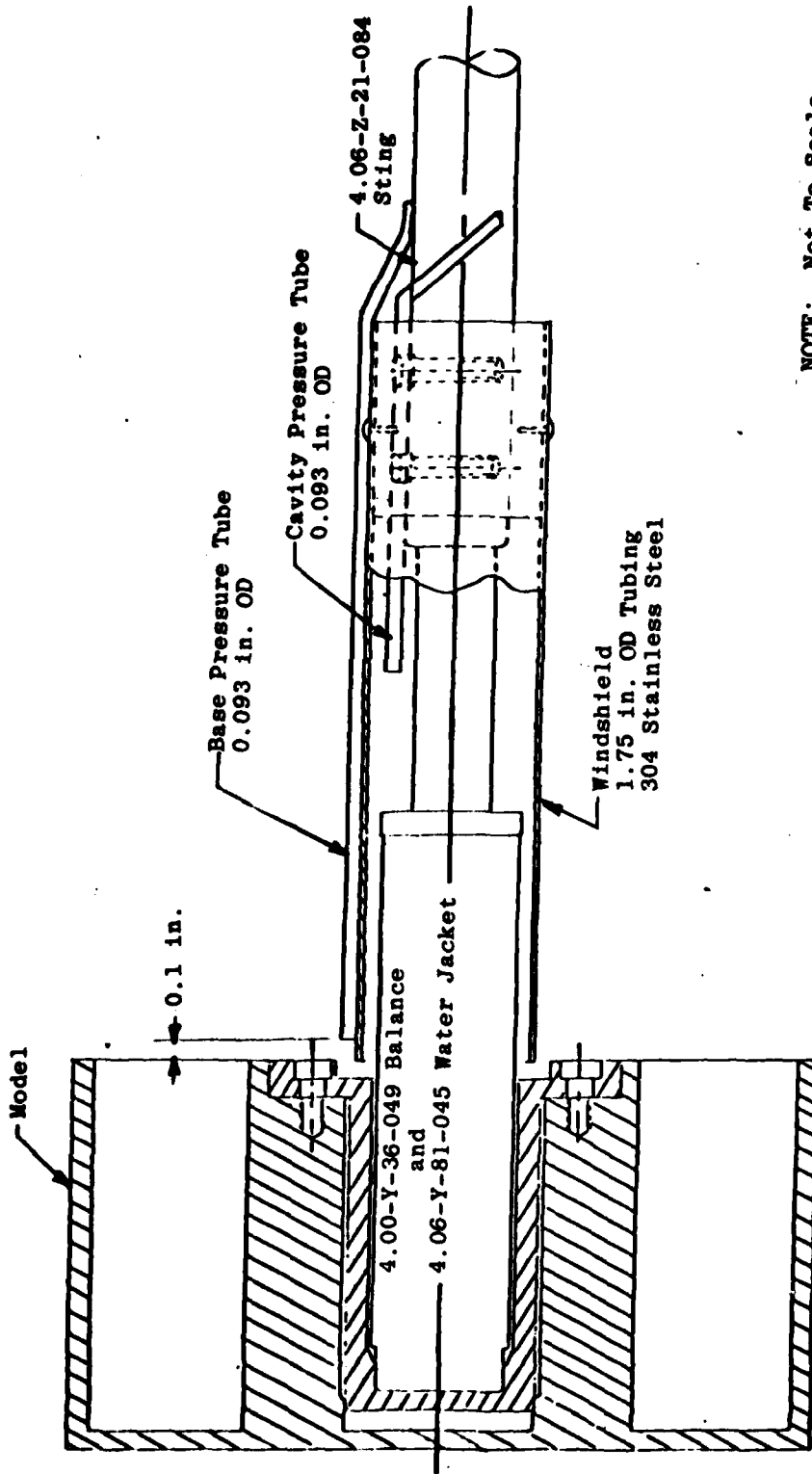
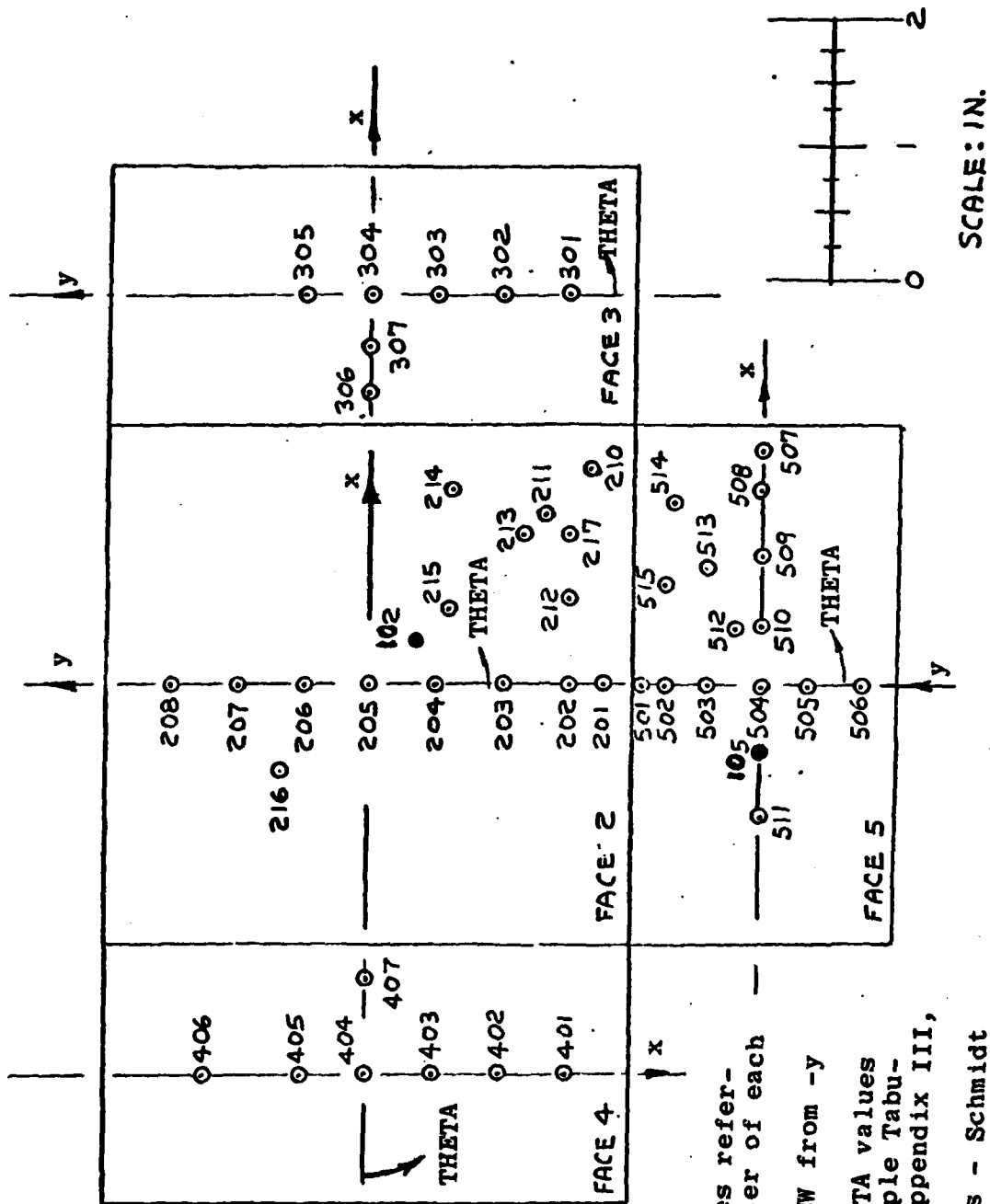

Figure 4. Force Model Details



NOTE: Not To Scale

Figure 5. Windshield with Pressure Tube Location



1. x and y values referenced to center of each face
2. THETA pos. CCW from -y axis
3. x, y, and THETA values listed on Sample Tabulated Data, Appendix III, Sample 1
4. Filled symbols - Schmidt Bouelster gages

Figure 7. Gage Locations

APPENDIX II

TABLES

TABLE 1. ESTIMATED UNCERTAINTIES
a. Basic Measurements

Parameter Designation	STEADY-STATE ESTIMATED MEASUREMENT*										Type of Measuring Device	Type of Recording Device	Method of System Calibration
	Precision Index (S)		Bias (B)		Uncertainty $\pm(B + 1.95S)$		Range	Type of Measuring Device	Type of Recording Device	Method of System Calibration			
	Percent of Reading	Unit of Measure	Degree of Freedom	Percent of Reading	Unit of Measure	Percent of Reading							
PT, psia	± 0.11	>30	± 0.25		± 0.91	275	WIANCO Variable Reluctance Transducer	Digital Data Acquisition System Analog to Digital Converter	0.1 Dead Weight Tester Secondary Standard				
TT, °F	± 1.0	>30	± 0.375		± 5.0	800	Chromel-Alumel Thermocouple	Doric Temperature Instrument/Digital Data Acquisition System	Thermocouple Verification by NBS Comparison/Voltage Substitution Calibration				
ALPI, deg	± 0.025	>30		0 ⁺	± 0.05	± 15	Potentiometer	Digital Data Acquisition System Analog to Digital Converter	Precision Inclination Meter Gage Reading				
PHII, deg	± 0.15	>30		0 ⁺	± 0.30	± 180	Gardon Gage	Beckman 210 Analog to Digital Converter	Comparison with Secondary Standard Gage				
QDOT, BTU/ft ² -sec	± 0.015	>30	± 2.0		$\pm (2.0\% + 0.03)$	<1	Iron-Constantan Thermocouple		Voltage Substitution				
TOE, °F	± 1.5	>30	± 2.0		± 5.0	1 to 10							
E, mv	± 0.1	>30		± 2.0	± 4.0	50 to 300							
Normal Force, lbs	± 0.161	>30		± 0.01	$\pm (0.01 + 0.2\%)$	0 to 5	Gardun Gage						
Pitching Moment, in.-lbs	± 0.160	>30		± 0.095	± 0.457	± 200	Six-Component Strain Gage	Digital Data Acquisition System Analog to Digital Converter	Static Loading				
Side Force, lbs	± 0.044	>30		± 0.103	± 0.423	± 600	Balance (4.00-Y-36-049)						
Rolling Moment, in.-lbs	± 0.071	>30		± 0.029	± 0.125	± 200							
Rolling Moment, in.-lbs	± 0.072	>30		± 0.013	± 0.185	± 600							
Rolling Moment, in.-lbs	± 0.059	>30		± 0.010	± 0.154	± 100							
Rolling Moment, lbs	± 0.0075	>30	± 0.3	± 0.038	± 0.156	0 to 100	RMS Transducers						
Longitudinal Moment Transfer Distance, in.	± 0.0025	>30		0 ⁺	$\pm (0.3\% + 0.0015)$	<1	Precision Height Gage and Micro-meters	Manual	In-place Air Dead Weight Calibration Calibrated in Standards Laboratory				

* Thompson, J. W. and Abernethy, R. B. et al. "Handbook Uncertainty in Gas Turbine Measurements." AEDC-TR-73-5 (AD 755356), February 1973.
+ Assumed to be zero

TABLE 1. Concluded
b. Calculated Parameters

Parameter Designation	STEADY-STATE ESTIMATED MEASUREMENT*										M/REX10 ⁻⁶	Remarks	
	Precision Index (S)			Bias (B)			Uncertainty ±(B + 19S)						
	Percent of Reading	Unit of Measure	Degree of Freedom	Percent of Reading	Unit of Measure	Percent of Reading	Unit of Measure	Percent of Reading	Unit of Measure	Unit of Measure			
K		0.015					0 ⁺				0.03		
P, psia		0.0003					0.0001				0.0009		
Q, psia		0.0106					0.0032				0.0244		
RHOx10 ⁻⁵ , lbm/ft ³		0.728					0.375				1.431		
V, ft/sec		1.48					7.03				9.99		
REX10 ⁻⁶ , ft ⁻¹		0.0069					0.0081				0.0219		
TW, °R	0.2					0.4				0.8			
H(TT)		2.1x10 ⁻⁵				2.1				2.1% + 4.2x10 ⁻⁵			510 to 760
	1.5					2.1				5.1			QDOT < 1
ST(TT)		2.7x10 ⁻⁵				2.1				2.1% + 5.1x10 ⁻⁵			QDOT > 1
	1.8					2.1				5.7			QDOT < 1
CNT		0.0067					0.0023				0.0157		
CN		0.0085					0.0026				0.0196		
CLM		0.0013					0.0004				0.0030		
CY		0.0010					0.0005				0.0025		
CLN		0.0010					0.0002				0.0022		
CLL		0.00027					0.00003				0.00057		
CAT		0.0146					0.0043				0.0335		
CA		0.0148					0.0044				0.0340		
ALPHA, deg		0.05					0 ⁺				0.10		
BETA, deg		0.05					0 ⁺				0.10		
PHIP, deg		0.20					0 ⁺				0.40		

*Abernethy, R. B. et al. and Thompson, J. W. "Handbook Uncertainty in Gas Turbine Measurements." AEDC-TR-73-5 (AD 755356), February 1973. Assumed to be zero

TABLE 2. Test Summary
a. Heat-transfer phase

CONFIG	ALPI	ALPPB	RUNS	REMARKS
FACE ON	0	0	1,2,23,24	Repeat runs. Shadowgraph movie taken of model sweeping between ± 10 deg after run 24
↓	1.0	↓	3	
↓	-5.0	↓	4	
↓	-10.0	↓	5	
↓	5.0	↓	6	
↓	10.0	↓	7	
↓	-5.0	20.0	8	
↓	0	↓	9	
↓	10.0	↓	10	
↓	0	40.0	11	
↓	5.0	↓	12,13	Repeat runs
↓	5.0	-20.0	14	
↓	0	↓	15	
↓	-2.5	↓	16	
↓	-5.0	↓	17	
↓	-7.5	↓	18	
↓	-10.0	↓	19	
↓	2.5	20.0	20	
↓	5.0	↓	21	
↓	7.5	↓	22	
SIDE ON	0	0	25,28	
↓	-10.0	↓	26	
↓	-5.0	↓	27	
↓	5.0	↓	29	
↓	10.0	↓	30	
↓	-10.0	20.0	31	Model angle of attack same as run 30
↓	-10.0	-20.0	32	
↓	-5.0	↓	33	
↓	0	↓	34	
↓	5.0	↓	35	
EDGE ON	-5.0	-40.0	36	
↓	-10.0	↓	37	
↓	0	↓	38	
↓	5.0	↓	39	
↓	10.0	↓	40	
↓	-5.0	↓	41	
CORNER ON	-5.0	-40.0	42,47	Model was rolled -45.0 about tunnel axis for runs 42 thru 47
↓	-10.0	↓	43	
↓	0	↓	44	
↓	5.0	↓	45	
↓	10.0	↓	46	
EDGE ON	-5.0	↓	48,53	Oil flow photographs only for runs 48 thru 53
↓	10.0	↓	49	
↓	0	↓	50	
↓	12.5	↓	51	
↓	14.5	↓	52	

TABLE 2. Concluded
b. Static Stability Phase

CODE	CONFIG	MODE ¹	MODEL ROLL ANGLE	ALPPB	RUN			
1	A	F	0	3	1 ² , 2, 3, 22 ²			
↓			↓	↓	30	23 ² , 24, 25, 34, 45 ² , 46		
↓			↓	22.5	↓	47, 48		
↓			↓	-22.5	↓	50		
↓			↓	67.5	↓	49		
2	B	S	-67.5	↓	51			
↓			↓	180	3	4 ² , 5		
↓			↓	↓	30	26 ² , 27, 28		
3			↓	90	3	6 ² , 7, 8		
↓			↓	↓	30	29 ² , 30		
4	C	F	0	3	9			
↓			↓	↓	30	31		
↓			↓	22.5	↓	52		
↓			↓	-22.5	↓	54		
↓			↓	67.5	↓	53		
5	D	F	-67.5	↓	55			
↓			↓	45	3	10		
6			↓	90	30	32		
↓			↓	↓	3	11		
7			↓	180	↓	12		
8	A	S	↓	30	33			
↓			↓	90	3	13		
9			↓	↓	30	35		
↓			↓	-90	↓	36		
10			B	F	0	3	14	
↓	↓	↓			30	37		
↓	↓	22.5			↓	56		
↓	↓	-22.5			↓	58		
↓	↓	67.5			↓	57		
11	C	F	-67.5	↓	59			
↓			↓	45	3	15		
12			↓	180	↓	16		
↓			↓	↓	30	38		
13			↓	90	3	17		
14	D	F	↓	30	39			
↓			↓	-90	↓	40		
15			A	F	0	3	18	
↓					↓	↓	30	41
↓					↓	22.5	↓	60
↓	↓	-22.5			↓	62		
↓	↓	67.5			↓	61		
16	B	F	-67.5	↓	63			
↓			↓	45	3	19		
17			↓	180	↓	20		
↓			↓	↓	30	42		
18			↓	90	3	21		
↓	C	F	↓	30	43			
19			↓	-90	↓	44		

¹ MODE: F - FACE-ON, S - SIDE-ON

² DATA TYPE: Point-pause run. All other runs are continuous sweep.

APPENDIX III

SAMPLE TABULATED DATA

ARG, INC. - AERC DIVISION
 A MEMBERSHIP CORPORATION COMPANY
 VON KARMAN GAS DYNAMICS FACILITY
 ARNOLD AIR FORCE STATION, TAMPSREF
 DORJE/CF CHR TEST
 PAGE 1

DATE COMPUTED 7-JAN-89
 TIME COMPUTED 20:18:23
 DATE RECORDED 7-DEC-79
 TIME RECORDED 1:49:17
 PROJECT NUMBER V41B-89

RUN CODE M KT TT D P T RE A REF LENGTHS(CLM,CLM,CLL)
 29 3 7.94 274.33 1264.7 1.288 0.029 92.5 0.133E+07 57.906 4.302 4.302 4.302

COSMIC
 A

---TUNNEL CONDITIONS---

BM	ALPI	PVEY	PT	TT	O	P	CAR	PR/P	CACAV	PCAV/P
1	13.97	0.00	274.33	1264.7	1.288	0.029	0.0052	0.5750	0.0004	0.5788
2	9.97	-0.00	274.33	1265.7	1.288	0.029	0.0052	0.5685	0.0004	0.5725
3	4.99	-0.00	274.44	1265.7	1.288	0.029	0.0055	0.5438	0.0004	0.5448
4	-0.01	0.01	274.34	1266.7	1.288	0.029	0.0057	0.5242	0.0004	0.5298
5	-5.01	0.01	274.34	1266.7	1.288	0.029	0.0053	0.5019	0.0004	0.5098
6	-10.00	0.00	274.36	1265.7	1.288	0.029	0.0046	0.4744	0.0003	0.4811
7	-14.20	0.01	274.25	1266.7	1.287	0.029	0.0038	0.4645	0.0003	0.4641

a. Tunnel conditions
 Sample 2. Sample Tabulated Static Force and Moment Data

DATE COMPUTED 7-JAN-88
 TIME COMPUTED 2011023
 DATE RECORDED 7-DEC-79
 TIME RECORDED 1149117
 PROJECT NUMBER V418-R9

ARO, INC. - AERC DIVISION
 A STEPHENSON CORPORATION COMPANY
 VON KARMAN GAS DYNAMICS FACILITY
 ARNOLD AIR FORCE STATION, TENNESSEE
 PORTAGE GPHS TEST
 PAGE 7

RUN CODE M PT TT Q P T Y RK A REF LENGTHS(CUM,CLM,CLL)
 29 3 7.94 274.33 1264.7 1.288 0.029 92.5 0.133E+07 57.906 4.302 4.302 4.302

CONFIG
 A

---BODY AXIS---

BA ALPHA	RLTP	PHI	CMT	CN	CLM	CYP	CX	CLN	CLL	CAT	CA	MCP/L	YCP/L
1 80.00	80.00	90.32	0.6204	0.6153	-0.0002	-0.5954	0.0007	-0.0033	-0.0022	-0.0022	-0.0022	0.0003	0.0012
2 80.00	80.00	90.31	0.6950	-0.6994	-0.0001	-0.5241	0.0009	-0.0149	-0.0021	-0.0021	-0.0021	0.0002	0.0017
3 80.00	80.00	90.31	0.7802	0.7743	-0.0000	-0.4207	0.0011	-0.0257	-0.0018	-0.0018	-0.0018	0.0000	0.0025
4 80.00	80.00	90.33	0.8553	0.8492	0.0001	-0.3129	0.0010	-0.0314	-0.0013	-0.0013	-0.0013	-0.0001	0.0032
5 90.00	90.00	90.33	0.9083	0.9076	0.0001	-0.2094	0.0009	-0.0290	-0.0006	-0.0006	-0.0006	-0.0001	0.0044
6 90.00	90.00	90.32	0.9447	0.9398	-0.0001	-0.1339	0.0010	-0.0220	-0.0007	-0.0007	-0.0007	-0.0001	0.0074
7 90.00	90.00	90.33	0.9653	0.9612	-0.0000	-0.0950	0.0011	-0.0192	-0.0005	-0.0005	-0.0005	0.0000	0.0111

---NON-ROLLING BODY AXIS---

PN ALPHA	RLTP	PHIP	ALPP	CHP	CLHP	CYP	CLMP	CLLP	CAP	MCP/L	YCPP/L
1 50.00	80.00	44.71	90.00	0.5920	-0.0007	0.6186	-0.0002	-0.0033	-0.0022	0.0012	0.0003
2 80.00	80.00	40.03	90.00	0.5204	-0.0009	0.6923	-0.0001	-0.0149	-0.0021	0.0017	0.0002
3 90.00	80.00	35.54	90.00	0.4165	-0.0011	0.7766	-0.0000	-0.0257	-0.0018	0.0016	0.0000
4 90.00	80.00	30.46	90.00	0.3081	-0.0010	0.8510	0.0001	-0.0314	-0.0013	0.0032	-0.0001
5 90.00	90.00	25.39	90.00	0.2042	-0.0009	0.9038	0.0001	-0.0289	-0.0006	0.0045	-0.0001
6 90.00	80.00	20.35	90.00	0.1246	-0.0010	0.9406	-0.0001	-0.0220	-0.0007	0.0077	0.0001
7 90.00	90.00	16.11	90.00	0.0894	-0.0011	0.9617	-0.0000	-0.0192	-0.0005	0.0116	0.0001

b. Body and nonrolling body axes
 Sample 2. Concluded

ATE
LMED
—8