

A7-AUB8 057

BOEING VERTOL CO PHILADELPHIA PA
DESIGN AND ANALYSIS OF CH-47 EXTERNAL CARGO HANDLING SYSTEM (SN--ETC(U)
OCT 79 T S GARNETT, R F CAMPBELL, D J HODDER DAAJ02-77-C-0069
D210-11555-1

F/8 1/3

UNCLASSIFIED

NL

Per 5

302005-

REVISED

LEVEL

(Handwritten circled 'P' with 'S' below it)

BOEING

AD A088057

**DESIGN AND ANALYSIS OF
CH-47
EXTERNAL CARGO HANDLING SYSTEM
(SNUBBED LOAD)**

**DTIC
SELECTED
AUG 18 1980**

THIS DOCUMENT IS BEST QUALITY PRACTICABLE.
THE COPY FURNISHED TO DDC CONTAINED A
SIGNIFICANT NUMBER OF PAGES WHICH DO NOT
REPRODUCE LEGIBLY.

DDC FILE COPY

This document has been approved
for public release and sale; its
distribution is unlimited.

RD 2 14 031

①

D210-11555-1

**DESIGN AND ANALYSIS OF
CH-47
EXTERNAL CARGO HANDLING SYSTEM
(SNUBBED LOAD)**

FINAL REPORT

OCTOBER 1979

By

Theodore S. Garnett, Jr.
Richard F. Campbell
David J. Hodder

DTIC
ELECTE
AUG 18 1980
D

Prepared by

BOEING VERTOL COMPANY
A DIVISION OF THE BOEING COMPANY

PHILADELPHIA, PENNSYLVANIA 19142

Prepared for

Applied Technology Laboratory
U. S. Army Research and Technology Laboratories
Fort Eustis, Virginia 23604

DAAJ02-77-C-0069

This document has been approved
for public release and sale; its
distribution is unlimited.

UNCLASSIFIED

SECURITY CLASSIFICATION OF THIS PAGE (When Data Entered)

REPORT DOCUMENTATION PAGE		READ INSTRUCTIONS BEFORE COMPLETING FORM										
1. REPORT NUMBER <u>C</u>	2. GOVT ACCESSION NO. <u>AD-A088057</u>	3. RECIPIENT'S CATALOG NUMBER										
4. TITLE (and Subtitle) <u>DESIGN AND ANALYSIS OF CH-47 EXTERNAL CARGO HANDLING SYSTEM (SNUBBED LOAD).</u>		5. TYPE OF REPORT & PERIOD COVERED <u>Final Report.</u> <u>September 1977-October 1979</u>										
7. AUTHOR(s) T. Garnett R. Campbell D. Hodder		6. PERFORMING ORG. REPORT NUMBER <u>D210-11555-1</u> A. CONTRACT OR GRANT NUMBER(s) <u>DAAJ02-77-C-0069</u>										
9. PERFORMING ORGANIZATION NAME AND ADDRESS Boeing Vertol Company/ P.O. Box 16858 Philadelphia, Pa. 19142		10. PROGRAM ELEMENT, PROJECT, TASK AREA & WORK UNIT NUMBERS <u>14 Oct 77</u>										
11. CONTROLLING OFFICE NAME AND ADDRESS Applied Technology Laboratory U.S. Army Research and Technology Laboratories Fort Eustis, Virginia 23604		12. REPORT DATE										
14. MONITORING AGENCY NAME & ADDRESS (if different from Controlling Office) <u>Mr. S. J. G. ... Jr.</u> <u>David T. Hodder</u>		13. NUMBER OF PAGES										
16. DISTRIBUTION STATEMENT (of this Report) <div style="border: 1px solid black; padding: 5px; text-align: center;">This document has been approved for public release and sale; its distribution is unlimited.</div>		15. SECURITY CLASS. (of this report) Unclassified										
17. DISTRIBUTION STATEMENT (of the abstract entered in Block 20, if different from Report)		15a. DECLASSIFICATION/DOWNGRADING SCHEDULE										
18. SUPPLEMENTARY NOTES												
19. KEY WORDS (Continue on reverse side if necessary and identify by block number)												
<table border="0"> <tr> <td>External Cargo Handling System (ECHS)</td> <td>MILVAN</td> </tr> <tr> <td>CH-47</td> <td>Gondola</td> </tr> <tr> <td>Snubbed Load</td> <td>Hoist</td> </tr> <tr> <td>Terrain Flight</td> <td>Vibration Isolation</td> </tr> <tr> <td>Cargo Lift Adapter - Helicopter (CLAH)</td> <td>Twistlock</td> </tr> </table>			External Cargo Handling System (ECHS)	MILVAN	CH-47	Gondola	Snubbed Load	Hoist	Terrain Flight	Vibration Isolation	Cargo Lift Adapter - Helicopter (CLAH)	Twistlock
External Cargo Handling System (ECHS)	MILVAN											
CH-47	Gondola											
Snubbed Load	Hoist											
Terrain Flight	Vibration Isolation											
Cargo Lift Adapter - Helicopter (CLAH)	Twistlock											
20. ABSTRACT (Continue on reverse side if necessary and identify by block number)												
<p>Development of a preliminary design concept to snub containerized external cargo loads to the CH-47 aircraft, for improved terrain and Night/IMC flight capability, has been completed. Results are suitable for detail design implementations leading to prototype demonstration of the system in the future. The External Cargo Handling System (ECHS) snubs loads (of up to 25,000 lbs. weight) against the helicopter landing gear, using a self hoisting adapter.</p>												

19. Key Words (Continued)

Guide Arms
 Landing Gear
 Masking
 Maneuverability
 Wind Tunnel

Generalized Load Snubbing Evaluation
 Adapter Aerodynamic Clean-up
 Gear Extension Arms
 Work Load

20. Abstract (Continued)

framework powered by 6 horsepower tandem electric hoists installed on non-linear vibration isolation mounts to interface the load with the aircraft. The ECHS snubbing adapter uses guide arms for load acquisition assistance, and twistlocks to lock the load to the adapter. No structural modification to the CH-47 is required. Compared to carrying cargo on conventional external sling suspension with a CLAH adapter, load snubbing provides a substantial performance benefit for terrain flight missions; and at the same time improves both masking and maneuverability along with capability for flight at night, or in IMC condition.

Accession For	
KTIS GRA&I	<input checked="" type="checkbox"/>
DCC TAB	<input type="checkbox"/>
Unannounced	<input type="checkbox"/>
Justification	
By	
Distribution/	
Availability Codes	
Dist	Avail and/or special
A	2

DISCLAIMER NOTICE

THIS DOCUMENT IS BEST QUALITY PRACTICABLE. THE COPY FURNISHED TO DTIC CONTAINED A SIGNIFICANT NUMBER OF PAGES WHICH DO NOT REPRODUCE LEGIBLY.

DDC AVAILABILITY NOTICES

1. Approved for public release; distribution unlimited
2. Distribution limited to U. S. Gov't. agencies only; (state reason indicated in a, b, c, d or e); _____(date statement applied). Other requests for this document must be referred to the Applied Technology Laboratory, US Army Research and Technology Laboratories (AVRADCOM), Fort Eustis, VA 23604
 - a. _____ Classified
 - b. _____ Contractor Performance Evaluation
 - c. _____ Foreign Information
 - d. _____ Proprietary Information
 - e. _____ Test and Evaluation

DISCLAIMER

3. The findings in this report are not to be construed as an official Department of the Army position unless so designated by other authorized documents.

4. When Government drawings, specifications, or other data are used for any purpose other than in connection with a definitely related Government procurement operation, the US Government thereby incurs no responsibility nor any obligation whatsoever; and the fact that the Government may have formulated, furnished, or in any way supplied the said drawings, specifications, or other data is not to be regarded by implication or otherwise as in any manner licensing the holder or any other person or corporation, or conveying any rights or permission, to manufacture, use, or sell any patented invention that may in any way be related thereto.

5. Trade names cited in this report do not constitute an official endorsement or approval of the use of such commercial hardware or software.

DISPOSITION INSTRUCTIONS

6. Destroy this report when no longer needed. Do not return it to the originator.

7. When this report is no longer needed, Department of the Army organizations will destroy it in accordance with the procedures given in AR 380-5.

PREFACE

This report presents a preliminary design and Critical Item Development Specification (CIDS) for an External Cargo Handling System (ECHS), suitable for snubbing containerized loads against the CH-47D airframe in order to substantially improve terrain and Night/IMC flight capability of this helicopter.

The work was sponsored by The Applied Technology Laboratory, U.S. Army Research and Technology Laboratories (AVRAD COM), Fort Eustis, Virginia, and was performed by the Boeing Vertol Company, Philadelphia, Pennsylvania; under contract DAAJ02-77-C-0069, "External Cargo Handling Systems (Snubbed Load)," during the period from September 1977 through October 1979.

The U.S. Army technical representative was Mr. Thomas B. Allardice. Contributions of Mr. Allardice and other Army personnel to this effort are gratefully acknowledged.

The following Boeing Vertol personnel contributed to the program:

Mr. B. B. Blake	- Manager, Flying Qualities Staff
Mr. T. S. Garnett	- Program Manager
Mr. R. F. Campbell	- Project Engineer
Mr. D. J. Hodder	- Wind Tunnel Project Engineer
Mr. V. Szewczyk	- Senior Design Technician
Mr. D. Breger	- Flying Qualities Engineer
Mr. F. White	- Senior Flying Qualities Engineer
Mr. D. Anastas	- Design Engineer
Mr. C. Robinson	- Flying Qualities Technician
Mr. L. Simpson	- Senior Design Engineer - Electrical Systems
Mr. P. A. Teare	- Senior Dynamics Engineer
Mr. J. McLaughlin	- Senior Engineering Technician

TABLE OF CONTENTS

<u>SECTION</u>	<u>PAGE</u>
PREFACE	3
LIST OF ILLUSTRATIONS	7
LIST OF TABLES	11
1.0 SUMMARY	13
1.1 Background and Approach	13
1.2 Program Ground Rules & Organization	15
1.3 Phase I - Concept Evaluation & Selection	16
1.4 Phase II/III - Preliminary Design & Layouts/CIDS Development	19
1.5 Phase IV - Snub Load Wind Tunnel Test Results	24
2.0 INTRODUCTION	33
3.0 PHASE I - CONCEPT ANALYSIS	41
3.1 Concept Evaluation & Selection	41
3.2 Vibration Isolation Analysis	48
3.3 Preliminary Hoist Concept Development	60
4.0 PHASE II/III - PRELIMINARY DESIGN, INCLUDING LAYOUTS/CIDS	65
4.1 System Description & Operation	65
4.2 Structural Arrangement	70
4.3 Load & Stress Analysis	78
4.4 Hoist Design	82
4.5 Vibration Isolator Development	89
4.6 Load Acquisition & Release	98
4.7 Electrical System	104
4.8 Airframe/Aircraft Modifications	111
4.9 Snubbed Load Dynamics (Air Resonance)	113
4.10 Safety and Emergency Operation	114
4.11 Costs and Weights	114
5.0 PHASE IV - CH-47 LOAD SNUBBING WIND TUNNEL RESULTS ANALYSIS	119
5.1 Generalized Load Snubbing Evaluation	126
5.2 Snubbing Adapter Aerodynamic Cleanup & Performance Assessment	133
5.3 Gondola Aerodynamic Evaluation	150

TABLE OF CONTENTS

<u>SECTION</u>	<u>PAGE</u>
6.0 CONCLUSIONS	165
7.0 RECOMMENDATIONS	167
8.0 REFERENCES	169
APPENDICES	171
A. CH-47 EXTERNAL CARGO HANDLING SYSTEM (SNUBBED LOAD): CRITICAL ITEM DEVELOPMENT SPECIFICATION (CIDS)	
B. SNUB LOAD WIND TUNNEL TEST DATA REPORT	
C. BREEZE CORPORATION, HOIST PROPOSAL	

LIST OF ILLUSTRATIONS

<u>Figure</u>		<u>Page</u>
1.1	Terrain Flight Definitions	14
1.2	CH-47 External Cargo Handling System (Snubbed Load)	18
1.3	Evolution of Load Snubbing Device	21
1.4	Snubbing Adapter Subsystems	23
1.5	Generalized Load Snubbing Evaluation	26
1.6	Effect of Load Snubbing on Lift	27
1.7	Snubbing Adapter Development	28
1.8	Comparison of Milvan Carried on Conventional and Snubbed Suspensions	30
1.9	Gondola Drag	32
2.1	Forward "DASH" Maneuver	34
2.2	Container Lift Adapter - Helicopter (CLAH) General Arrangement	38
3.1	Configurations Maintaining Tension On Cables	44
3.2	Configurations Locking to Fuselage - No Tension on Cables	45
3.3	No. 8 Selected Configuration	46
3.4	Forward Landing Gear Properties	53
3.5	Aft Landing Gear Properties	54
3.6	Effect of Support Isolation on Frequency Placement for Snubbed Load Configurations 1 & 8 (Tandem Hooks)	56
3.7	Effect of Support Isolation on Frequency Placement for Snubbed Load Configuration 7 (Three Hook Redundant)	57
3.8	Effect of Support Isolation on Frequency Placement for Snubbed Load Configuration 6 (Tandem Hook + Bumpers on Frame)	59
3.9	CH-47C Vibratory Gear Motions with Snubbed External Loads	61

LIST OF ILLUSTRATIONS (Continued)

<u>Figure</u>		<u>Page</u>
4.1	General Arrangement of Original (Phase II) Adapter	66
4.2	General Arrangement of ECHS Final Adapter	67
4.3	Initial Phase II Structural Design	71
4.4	Final ECHS Structural Design	73
4.5	Wheel Pad Structure - Detail	74
4.6	Wheel Pad Structure - Detail	75
4.7	Hoist Support Structure	76
4.8	Center Hook Redundant Safety Attachment	77
4.9	Geometry of Snubbed Load	79
4.10	Hoist Cable Eye End	86
4.11	Hoist Design - Boeing Vertol Concept	87
4.12	Hoist Design - Existing Breeze BL-6700	88
4.13	Hoist Design - Western Gear Concept	90
4.14	Hoist Design - All American Concept	91
4.15	Hoist Design - Breeze Concept	92
4.16	Isolator Requirements and Geometry	93
4.17	Elastomeric Isolator Concept	95
4.18	Installation of Isolator Spring	96
4.19	Isolator Spring Characteristics	97
4.20	Twistlock Push-Pull Rod Actuator Arrangement	99
4.21	Twistlock Housing	100
4.22	Interlock Plunger Switch	102
4.23	Twistlock Position Indicators	103
4.24	Twistlock Alignment Limits	105
4.25	Electrical System Concept	106
4.26	Electrical Control Panel	108
4.27	Landing Gear Pad Switch	110
4.28	Order-of-Magnitude Costs for ECHS	116
4.29	Production Cost Breakdown - Initial Two Units	116

LIST OF ILLUSTRATIONS (Continued)

<u>Figure</u>		<u>Page</u>
5.1	Snubbed Load Wind Tunnel Test Equipment	121
5.2	Baseline Fuselage Drag	122
5.3	" " Lift	123
5.4	" " Pitching Moment	124
5.5	" " Yawing Moment	125
5.6	CH-47 Model Configured with MILVAN for "Generalized" Load Snubbing Evaluation	127
5.7	"Generalized" Load Snubbing Evaluation with MILVAN	128
5.8	Effect of Load/Fuselage Separation on MILVAN Drag	129
5.9	Effect of Load/Fuselage Separation on MILVAN Lift	130
5.10	Effect of Load/Fuselage Separation on MILVAN Pitching Moment	131
5.11	Effect of Load/Fuselage Separation on MILVAN Yawing Moment	132
5.12	Comparison of MILVAN Strut Tare Drag	134
5.13	" " " " " Lift	135
5.14	" " " " " Pitching Moment	136
5.15	Comparison of MILVAN Tandem Strut Tare Yawing Moment	137
5.16	CH-47 Model Configured with Initial Phase II/III Snubbing Adapter at Start of Aerodynamic Cleanup Testing	138
5.17	Cleaned Up Snubbing Adapter & MILVAN Load	139
5.18	Aerodynamic Configuration Development of Snubbing Adapter - Drag	140
5.19	Aerodynamic Configuration Development of Snubbing Adapter - Lift	141
5.20	Aerodynamic Configuration Development of Snubbing Adapter - Pitching Moment	142
5.21	Aerodynamic Configuration Development of Snubbing Adapter - Yawing Moment	143
5.22	Adapter Aerodynamic Configuration - "Clean-Up"	146

LIST OF ILLUSTRATIONS (Continued)

<u>Figure</u>		<u>Page</u>
5.23	Effect of Load Snubbing on Lift	147
5.24	Comparison of MILVAN Carried on Conventional and Snubbed Suspensions	148
5.25	CH-47 Model with Load Gondola Mounted on Simulated Inverted "Vee" Suspension Slings	151
5.26	Gondola Aerodynamic Evaluation	152
5.27	Effect of Internal Load on Gondola Aerodynamics - Drag	153
5.28	Effect of Internal Load on Gondola Aerodynamics - Lift	154
5.29	Effect of Internal Load on Gondola Aerodynamics - Pitching Moment	155
5.30	Effect of Internal Load on Gondola Aerodynamics - Yawing Moment	156
5.31	Effect of 10" "Vee" Struts on Fuselage Drag	157
5.32	" " " " " " " Lift	158
5.33	" " " " " " " Pitching Moment	159
5.34	Effect of 10" "Vee" Struts on Fuselage Yawing Moment	160
5.35	Gondola/MILVAN Comparison on Snubbing Adapter - Drag	161
5.36	Gondola/MILVAN Comparison on Snubbing Adapter - Lift	162
5.37	Gondola/MILVAN Comparison on Snubbing Adapter - Pitching Moment	163
5.38	Gondola/MILVAN Comparison on Snubbing Adapter - Yawing Moment	164

LIST OF TABLES

<u>Table</u>		<u>Page</u>
2.1	CH-47 Terrain Flying Effectiveness (with an Empty MILVAN Container)	35
3.1	System Features Considered in Load Snubbing Concept Selection	47
3.2	Load Snubbing Concept Evaluation	49
3.3	Isolator Considerations	55
3.4	Load Snubbing Hoist - Preliminary Considerations & Design	62
4.1	Flight Maneuver Design Conditions	80
4.2	Results of Load Analysis	81
4.3	Stress Analysis	83
4.4	Aircraft Modification Summary	112
4.5	Projected Weights for ECHS	117

1.0 SUMMARY

1.1 BACKGROUND AND APPROACH

Army cargo and utility helicopters form an important link in the logistical chain which must deliver supplies and equipment to troops deployed in rapidly moving forward battle areas (FEBA). In many instances, the tactical application of helicopter airlift capability is the only practical way to meet an ever changing battle situation effectively. With this assigned mission responsibility, it is obvious that weather, darkness, and the enemy threat are factors which require careful consideration to ensure successful task accomplishment.

Helicopter flight operations near to the FEBA dictate the use of Nap of the Earth (NOE), Contour, and Low Level terrain flight techniques (Figure 1.1), in order to counter the sophisticated and possibly lethal air defense threat existing today. Terrain flying with external cargo (which is necessary in certain battlefield resupply scenarios) requires agile flight maneuvering close to the ground or shielding provided by natural obstructions, in order to hide the aircraft from enemy detection (called masking).

Because of excessive load oscillations characteristic of external cargo suspension systems in use today, the potential for restricting helicopter terrain maneuverability, and flight characteristics at night or in limited visibility/IMC conditions, exists. In addition, minimum safe flight altitudes with external loads slung beneath the aircraft are somewhat higher than with internal cargo, with the result that masking effectivity is reduced accordingly.

Contract DAAJ02-76-C-0028 (Reference 1) funded an in-depth flight simulation study to determine "Limitations of the CH-47 Helicopter in Performing Terrain Flying with External Loads". Study results defined and quantified aircraft capability to successfully perform terrain flight maneuvers (which is substantial), and at the same time delineated problem areas and limitations associated with this type of flying. Specific maneuvers selected for this evaluation are shown in the Figure 1.1 sketch, and are grouped into the NOE, Contour, and Low Level modes chosen for quantitative comparisons made during the study.

To overcome limitations identified in the Reference 1 study, a cargo handling concept, capable of firmly "snubbing" a MILVAN or Gondola container to the CH-47 aircraft fuselage was proposed as an effective technical approach. By preventing load motion relative to the airframe, this device restored aircraft maneuverability typically lost where conventional external load suspensions were utilized, and provided for vastly improved masking characteristics as well.

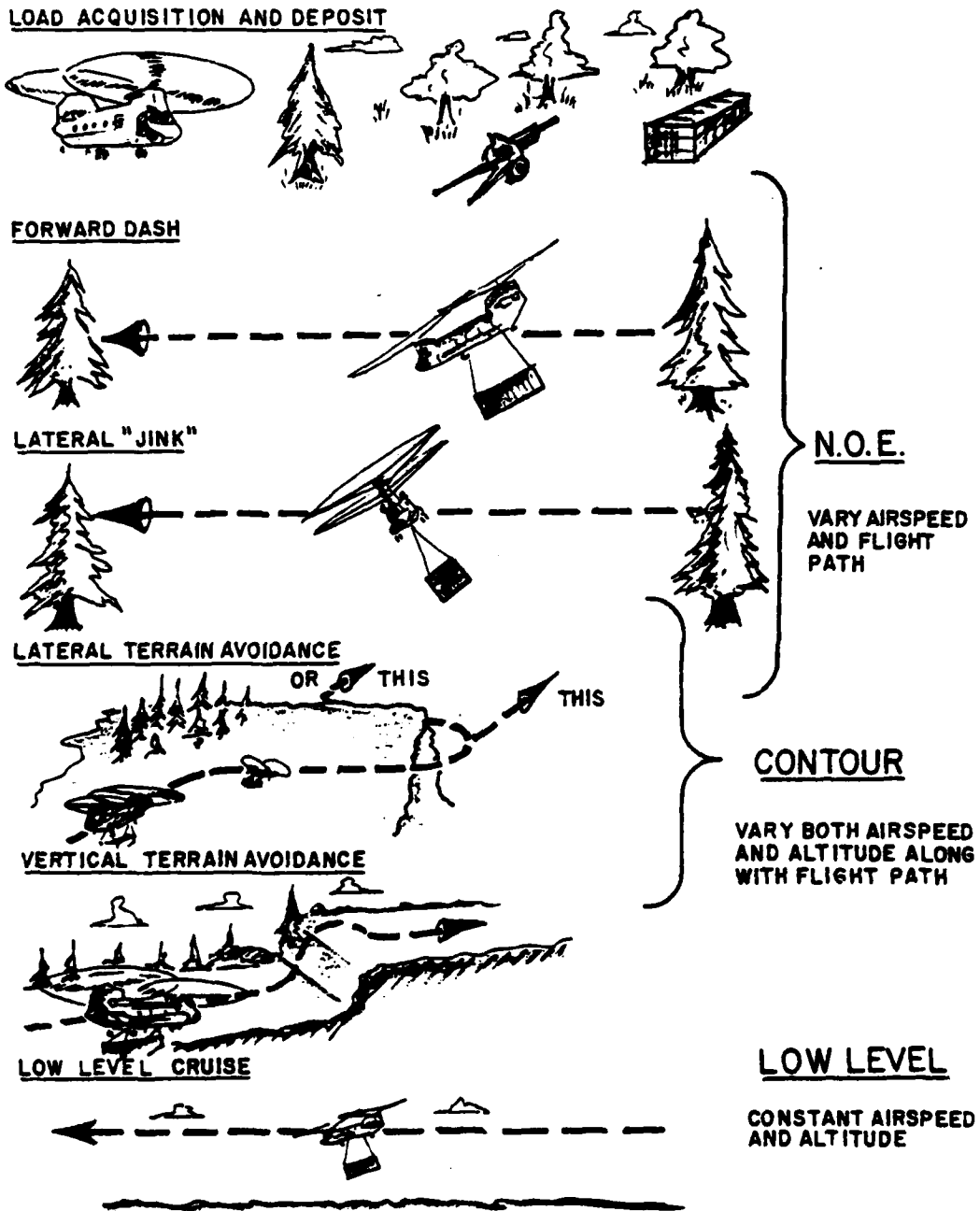

Figure 1.1 Terrain Flight Definitions

This report documents the continued development of the load snubbing concept into a Preliminary Design and Critical Item Development Specification (CIDS), under contract DAAJ02-77-C-0069, "CH-47 External Cargo Handling Systems (Snubbed Load)" described in Reference 2. The Preliminary Design layouts and CIDS information presented herein are applicable to any follow-on detail design effort leading to fabrication of prototype or production load snubbing systems for the CH-47D aircraft.

In addition to background requirements defined under the Reference 1 terrain flying study, the new snub load developmental activity described in this report leans heavily upon work performed when the Container Lift Adapter-Helicopter (CLAH) system was designed for the Army in 1976/77 (under contracts DAAJ02-76-C-0005 and DAAJ02-77-C-0001 - References 3 and 4). The CLAH is intended to serve as a standard interfacing device for carrying cargo containers, and will normally be carried on conventional tandem or single point suspensions. Use of this adapter facilitates load acquisition and deposit without the necessity of ground crew personnel, and requires no pre-rigging of MILVAN or Gondola payloads.

1.2 PROGRAM GROUND RULES & ORGANIZATION

Contract ground rules established at the start of the External Cargo Handling Systems (ECHS) developmental effort require that the ECHS design shall:

- Be compatible with the CH-47D aircraft
- Be compatible with MILVAN and Gondola container payloads
- Be capable of snubbing 25,000 lb
- Maximize simplicity
- Require minimum aircraft modification
- Stress low cost and weight
- Consider cargo only - not personnel

In order to best comply with these ground rules, the program was initially demarcated into three distinct phases of activity. A fourth phase was added midway through the program to increase confidence in the design concept selected, as indicated below:

- Phase I - Concept Evaluation & Selection

- Phase II - Preliminary Design
 - Phase III - Layout and CIDS Preparation
- Added by Contract Amendment:
- Phase IV - Wind Tunnel Tests

A brief review of the results of each program phase is presented next.

1.3 PHASE I - CONCEPT EVALUATION & SELECTION

The principal objectives of the initial program phase were to select the best concept for snubbing and attaching loads to the aircraft, with minimum airframe structural modification required; to establish whether or not vibration isolation of the load is necessary for either aircraft safety or crew comfort; and finally to review existing aircraft hoisting hardware for potential application in the Phase II/III Preliminary Design and CIDS preparation.

Concept Selection - Using the load snubbing approach developed during the Reference 1 Terrain Flying Study as a starting point, a number of different ways to interface the load and airframe (in a "snubbed" configuration) were conceived, and were then evaluated quantitatively to select the best system for further design development. Early on, it became apparent that requirements for rapid acquisition and deposit of the load by the CH-47 helicopter (without ground crew assistance) would dictate major design constraints for the snubbing system.

Two approaches available for use in load acquisition/deposit were to: either use a CLAH like adapter framework with guide arms for mechanically centering and acquiring the load; or to install an HLH type velocity control mode in the CH-47 Automatic Flight Control System (AFCS) to improve hover accuracy for precision load acquisition. Although both approaches had previously been demonstrated to be technically feasible, the second option was eliminated because of contractual requirements for minimum aircraft modification.

Accordingly, eight concepts for snubbing loads to the aircraft with various types of adapter mounting/suspension systems were developed for evaluation. Four of these utilized an adapter mounted hoist to raise the load to the snubbed position beneath the aircraft; whereupon the load was firmly locked to a vibration isolation system on the airframe, and the hoist cables slacked off. The remaining four candidates utilized the hoists in the same manner, but maintained load on the hoist cables during normal flight.

Various isolation springs, bumpers, over center latches etc. were interposed between the adapter (carrying the load), and the fuselage to provide a snubbing interface. One system even used a large flat air bag spring for isolation. System concepts "locking" the load to the airframe turned out to be somewhat heavier and more cumbersome than those maintaining load on the cables; because of redundant structural load paths required in the airframe for load attachment or snubbing.

Quantitative (weighted) comparisons of all candidate systems indicated a strong preference for snubbing the adapter/load combination against the aircraft landing gear as shown at the bottom of Figure 1.2. Although this sketch represents the final preliminary system (CIDS) design, with Phase IV wind tunnel mods incorporated, it is essentially the "winning" concept developed under the Phase I parametric concept selection process.

System Operation - As shown at the top of Figure 1.2, the adapter is lowered in hover, 10-12 feet below the aircraft and acquires the load through use of self-centering spring tube guide arms. Twistlocks at the corner of the adapter lock the load in place (to the adapter), and the aircraft lifts the load off of the ground into stabilized hover. A tandem hoist system installed in the adapter then raises the load to snub against the aircraft landing gear (which provide partial vibration isolation of the load from the airframe). Additional vibration isolation springs installed in the hoist mounts (described later), provide the remaining required isolation.

For protection from forward or aft suspension failures (including inadvertant operation of either tandem hook), a center hook redundant latch system is incorporated into the ECHS adapter framework. This latch carries no load under normal system operating conditions, but picks up (and retains) most of the load if either suspension malfunctions. Should it become necessary to salvo the load in flight, the normal CH-47D cargo hook jettison functions are utilized to release all three hooks simultaneously.

When the snubbed load mission is completed, cargo deposit on the ground is achieved by reversing operational procedures executed by the aircrew during load acquisition.

Vibration Isolation - An in-depth analysis of the potential vibration characteristics of snubbed external payloads indicated that isolation of the load (from the airframe) would be necessary. Unlike conventional external cargo suspensions (which have inherent vibration isolation due to the elastic characteristics of nylon slings), a snubbed load attached to

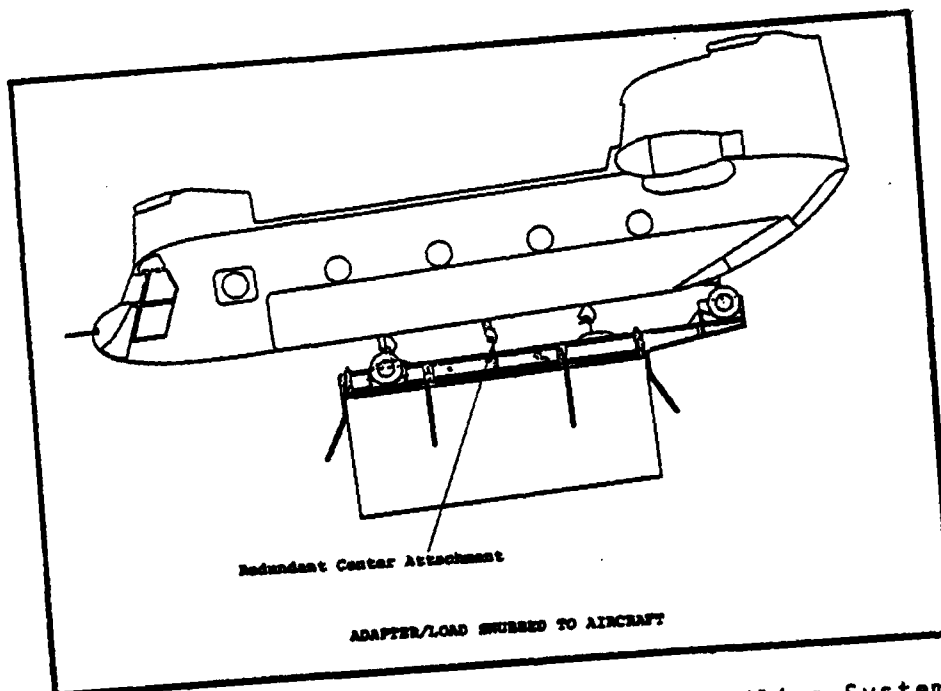
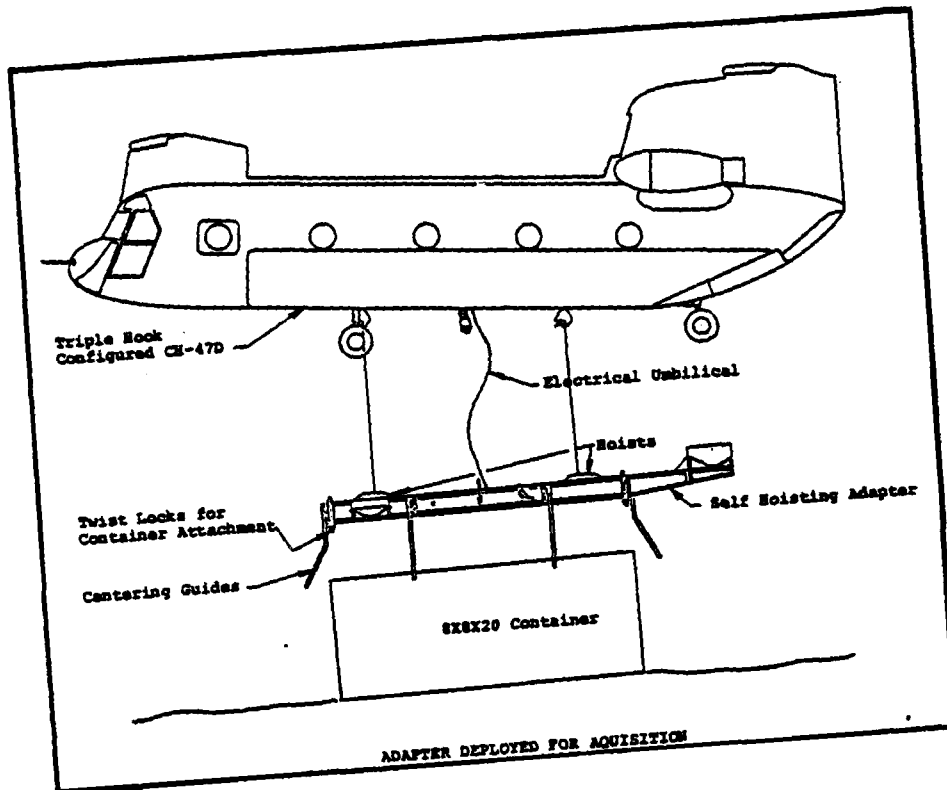

Figure 1.2 CH-47 External Cargo Handling System (Snubbed Load)

the aircraft behaves more like an internal cargo configuration. Using the internal load analogy applied in design of an isolated floor for early model CH-47 aircraft, it was determined that placement of the snub load principal vertical and pitch modal frequencies at about 8 Hz, would prevent load vibratory motion amplification in the critical one and three-per-rev rotor frequency range.

A scheme to achieve 8 Hz isolation, using a simple non-linear (but otherwise) conventional steel spring at each hoist attachment, was devised. The hoist isolation spring acts in series with the spring rate of airframe backup structure installed to mount each cargo hook. These two springs, in turn, operate in parallel with gear oleo bottoming springs, to form the complete load vibration isolation system. The non-linear characteristic of the hoist spring maintains constant 8 Hz load frequency, for all cargo payload weights from 5000 to 25000 lbs.

Hoist System - Parametric evaluations of the hoist system requirement in Phase I revealed that tandem hoist configurations were significantly lighter than comparable single hoist/pulley-sheave arrangements, for snubbing the load/adaptor combination to the airframe. Hoist electrical power requirements, compatible with what is available aboard the CH-47 aircraft (to power such auxiliary devices), dictated the use of about 5.5 to 6 horsepower motors to drive each hoist drum. Flexible hoist cable (0.625 inches in diameter) was required to support the ECHS and cargo payload during design flight maneuvers. Another cable with 0.70 inch diameter, developed for the HLH helicopter hoist system (and described in Reference 5) was determined to be a suitable substitute for the ECHS prototype system development; and a preliminary hoist layout developed by Boeing Vertol to solicit vendor hoist design responses reflected use of the HLH cable.

No suitable existing hoist system hardware was found to be available which could be used directly in the ECHS developmental effort without extensive, or costly modification.

1.4 PHASE II/III PRELIMINARY DESIGN & LAYOUTS/CIDS DEVELOPMENT

On the basis of Phase I results which selected the gear-snubbing concept for further development, a set of preliminary design criteria were adopted to guide the remaining design activities. Principal criteria included the following requirements for the snubbing system:

- Acquire and snub std 8 x 8 x 20 MILVAN/ISO CONTAINER/Gondola
- Maximum load - 25,000 lb
- Limit loads - 2g, or those resulting from critical maneuvers (as defined in structural design of the CH-47D triple hook system)
- Ultimate load factor - 1.5
- Hoists: Max speed 10 ft/min
 - 12 ft cable length (max load)
 - 22 ft cable length (no load)
- Fail-safe suspension - load retained after single suspension failure

Structural Arrangement - Figure 1.3 presents a sketch of the ECHS adapter framework developed for snubbing container payloads against the CH-47 landing gear. At the top of the figure is shown the initial Phase II/III design, with extensions protruding from a central box framework to provide support for the four landing wheel interfacing pads. Guide arms for centering the adapter on the load during acquisition are shown, along with corner twistlocks to attach the load to the adapter. Guide and twistlock design technology was based on the earlier CLAH developmental work (References 3 and 4).

At the bottom of Figure 1.3 is the final revised ECHS design; reflecting modifications resulting from changes made to the original configuration during the Phase IV wind tunnel test (discussed later). Principal among the structural revisions was a widening and thinning of the adapter to conform to the lateral dimensions of the 8 foot MILVAN load; and a 3° nose-up increase in positive incidence angle, at which the adapter is snubbed to the landing gear. These two changes, along with a rounding of the adapter forward edge, produced a significant improvement in aerodynamic flow over the snubbed load.

Subsystem Development - In addition to the adapter framework, principal ECHS subsystems developed during the Phase II/III effort included:

- The vibration isolation system
- The hoist system
- The ECHS electrical power and control systems

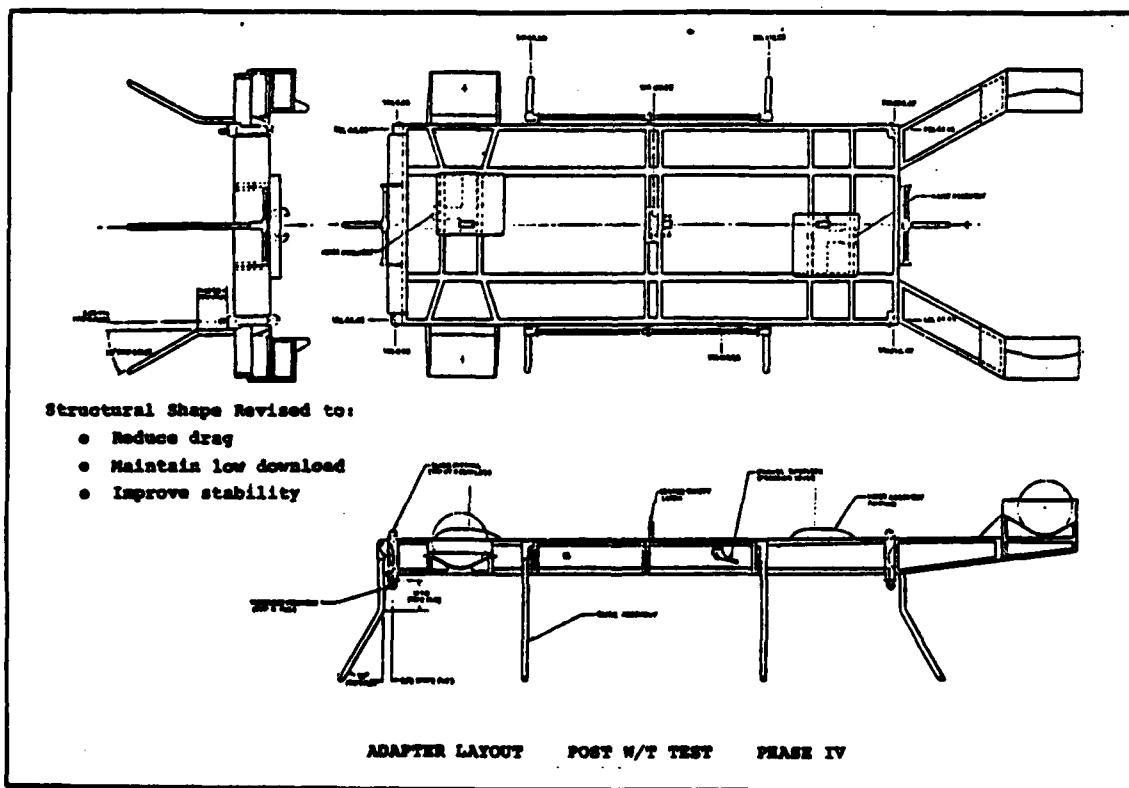
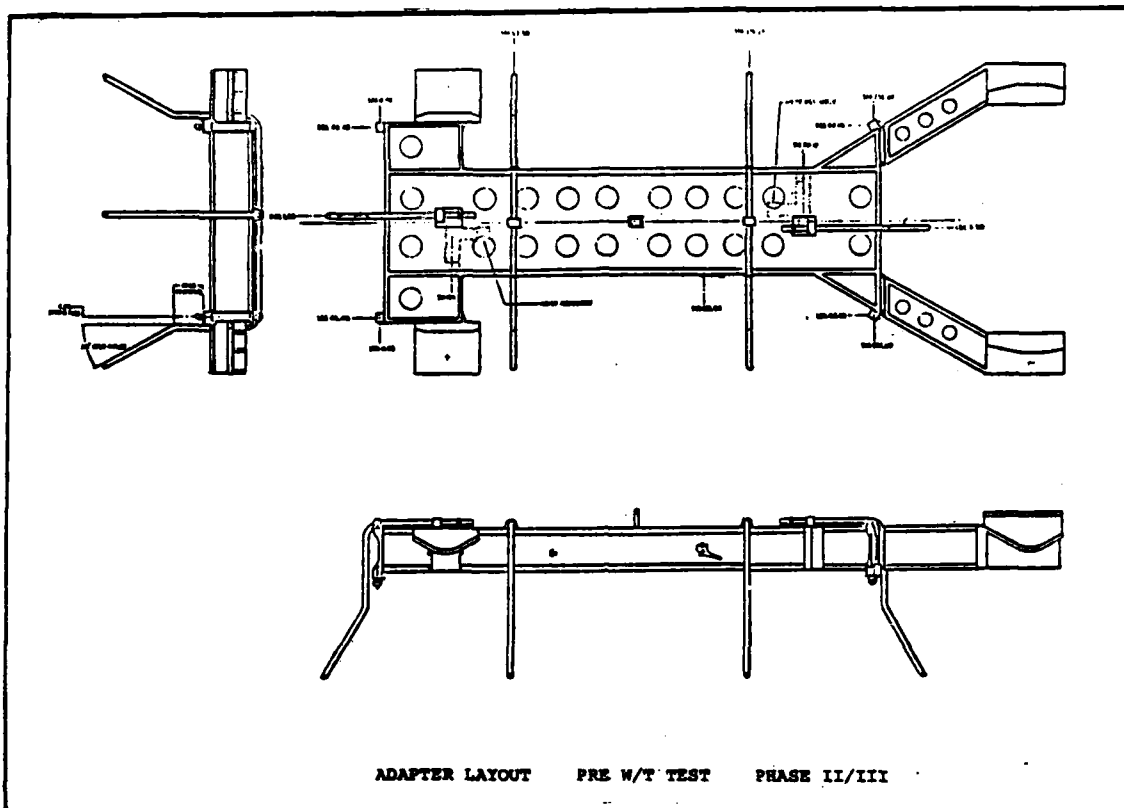

Figure 1.3 Evolution of Load Snubbing Device

All three subsystem elements are illustrated in the Figure 1.4 sketches.

Isolator - At the top of the figure is shown the hoist mounting scheme which provides the non-linear vibration characteristics determined to be necessary in Phase I. With the 8 to 1 moment arm ratio shown, spring rates required at the cable (which vary from about 13,000 lb/inch for minimum load, to ones 200,000 lb/inch when the hoist is loaded to 10,000 lbs) are reduced at the isolator spring by a factor of 64 (which is the moment arm ratio squared). This design feature permits the generation of high spring rates at the suspension cable, with a relatively light and compact non-linear spring grounded to the adapter structure. Decreasing coil pitch, incorporated into the constant diameter spring when it is fabricated, allows individual coils to bottom as the load is increased; and this in turn raises the stiffness as the spring is compressed.

Hoist Selection - With the preliminary design concept developed under Phase I as a guide, proposals for development of a suitable hoist system were solicited from industry. The three responses received reflected the work of the Western Gear Corporation, All American Engineering and the Breeze Corporation.

The Breeze response (shown at the center of Figure 1.4) best met requirements for a highly efficient, lightweight system, which would fit into the envelope restrictions of the ECHS adapter framework. This device reflected use of an existing 6 horsepower hoist motor, and technology used in other hoists currently produced by the company. Projected efficiency of the drive gearing system was superior to others proposed - and this is a significant fact - since aircraft electrical power available to power the hoist is limited (especially when one considers potential installation of sophisticated additional NAV/COM equipment on the aircraft in the future to permit effective terrain flying in battle situations).

Electrical System - The electrical system schematic shown at the bottom of Figure 1.4 reflects all major sub-system components required for ECHS operation. Aircraft AC and DC power is used to activate the twistlocks and to power the hoist systems. A carry on controller is mounted in the aircraft at the cargo hatch, and an override capability is provided to the pilots in the cockpit. Operation of this ECHS controller is normally performed by the aircraft crew chief, while looking at the load through the cargo hatch. All power to ECHS adapter subsystems is supplied through a self-reeling umbilical cable (with breakaway fittings for emergency jettison).

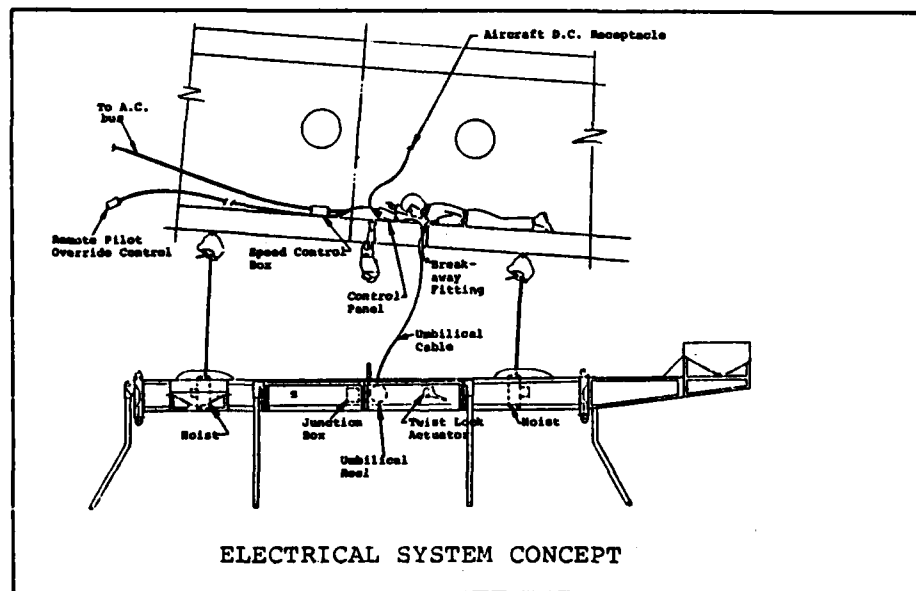
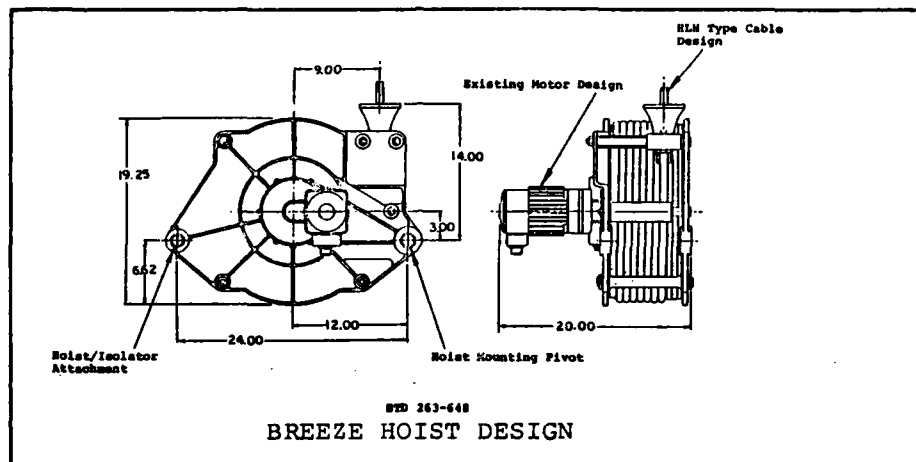
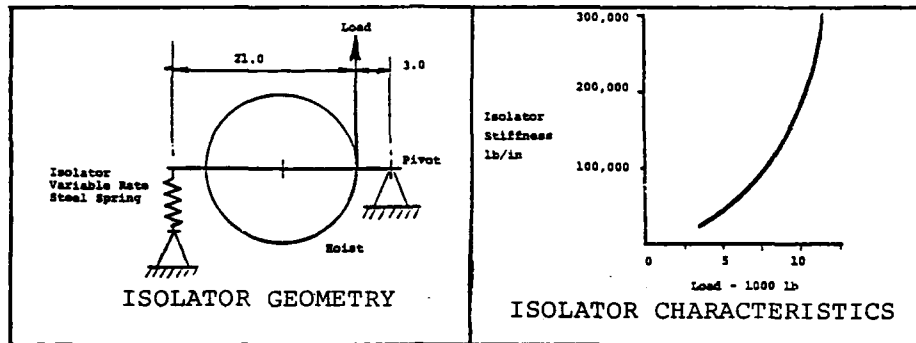

Figure 1.4 Snubbing Adapter Subsystems

An additional interconnect with the aircraft electrical/AFCS system is also provided. This function disables the gear - squat switch - AFCS signal (when the load is snubbed), to prevent AFCS reversion in flight, to its on-ground mode of operation during maneuvers.

Aircraft Modification Kit - As indicated earlier, the ECHS adapter concept selected for development requires no structural modification to the aircraft for system interfacing. Additions to the helicopter electrical system are:

- Receptacles for ECHS AC power cable attachment
and
- Landing gear squat switch - AFCS signal disable interconnection

Other ECHS system elements can be removed from the aircraft, any time load snubbing missions with container payloads are not being conducted.

System Weights - Estimates of prototype and mature production ECHS system weights revealed that the snubbing device would only exceed the weight of the CLAH by 558 to 970 pounds. This weight delta is more than compensated for, by substantially reduced aerodynamic downloads experienced with the snubbed configuration (as will be shown in the wind tunnel results presented later in this section).

The projected prototype ECHS system weight is on the order of 1870 pounds. With application of composite structural elements and lightened hoist components (which are well within state of the art limits), this weight is expected to decrease to about 1460 pounds for a system designed for quantity production.

Critical Item Development Specification (CIDS) - A detailed CIDS has been prepared for the ECHS, and is included as an Appendix to this report. This specification delineates all major system (and sub-system) design and performance requirements, necessary for detail design implementation leading to a prototype hardware demonstration of the load snubbing concept on a CH-47D helicopter.

1.5 PHASE IV - SNUB LOAD WIND TUNNEL TEST RESULTS

Results of Phase IV wind tunnel tests to evaluate aerodynamic viability of the load snubbing concept are summarized in Figures 1.5 through 1.9. The principal purpose of this testing, with a 1/8 scale CH-47 drag model, was to determine whether or not load snubbing causes any aerodynamic problem

that would invalidate the concept, as a method for future improvement of terrain and night/IMC flight capability with external loads.

Wind tunnel data clearly indicated the snubbing concept to be both sound and technically feasible. In fact, snubbing MILVAN and Gondola loads on the adapter framework shown in Figure 1.3 improves overall performance capability, when compared to conventional load suspension systems employing the CLAH. Testing was conducted in three phases, and each is summarized briefly below.

Generalized Load Snubbing Evaluation - Figures 1.5 and 1.6 summarize the principal effects of mounting a MILVAN container at various distances beneath the fuselage bottom, in order to determine potential aerodynamic interference relationships as the load is drawn closer to the airframe in intervals, ending with the snubbed position. Both figures show a reduction in aerodynamic penalty when the load approaches the fuselage (Figure 1.5 indicates reduced drag in the cruise angle of attack range of the aircraft, and Figure 1.6 reveals less download or negative lift). These results were at first puzzling, since increased drag and download were expected to go hand and hand with the snubbing process.

What actually occurred was a modification of airflow around the aircraft ramp; which, in effect, "decambered" the fuselage and substantially reduced its induced drag, as the load was brought closer and closer to the aircraft lower surface. Concurrent with improved drag and lift characteristics, was an improvement in static directional stability (N_{β}) at low yaw angle, and a neutral pitch stability (M_{α}) contribution of the load. These stability characteristics are significant, since no modification to the aircraft AFCS is required when carrying loads in the snubbed configuration.

Adapter Aerodynamic Cleanup & Performance Summary - Figure 1.7 reflects a 20 ft² drag improvement achieved during "cleanup" testing of the Phase III adapter framework sketched at the top of Figure 1.3. As indicated earlier, widening and changing the adapter incidence (as shown at the bottom of this figure) produced this drag reduction with the MILVAN installed. A 20 ft² drag improvement increases normal power speed by 4 to 5 knots, and reduces aircraft power required by about 400 shaft horsepower (both of which are worthwhile when considered in the context of fleet life cycle fuel costs etc.)

Also shown for comparison in Figure 1.7 are drag results for a MILVAN supported on a level, equal length, 10 foot full scale simulated sling suspension (just as the model was tested in the "generalized" snubbing evaluation discussed above). Flight test experience indicates that in order to achieve

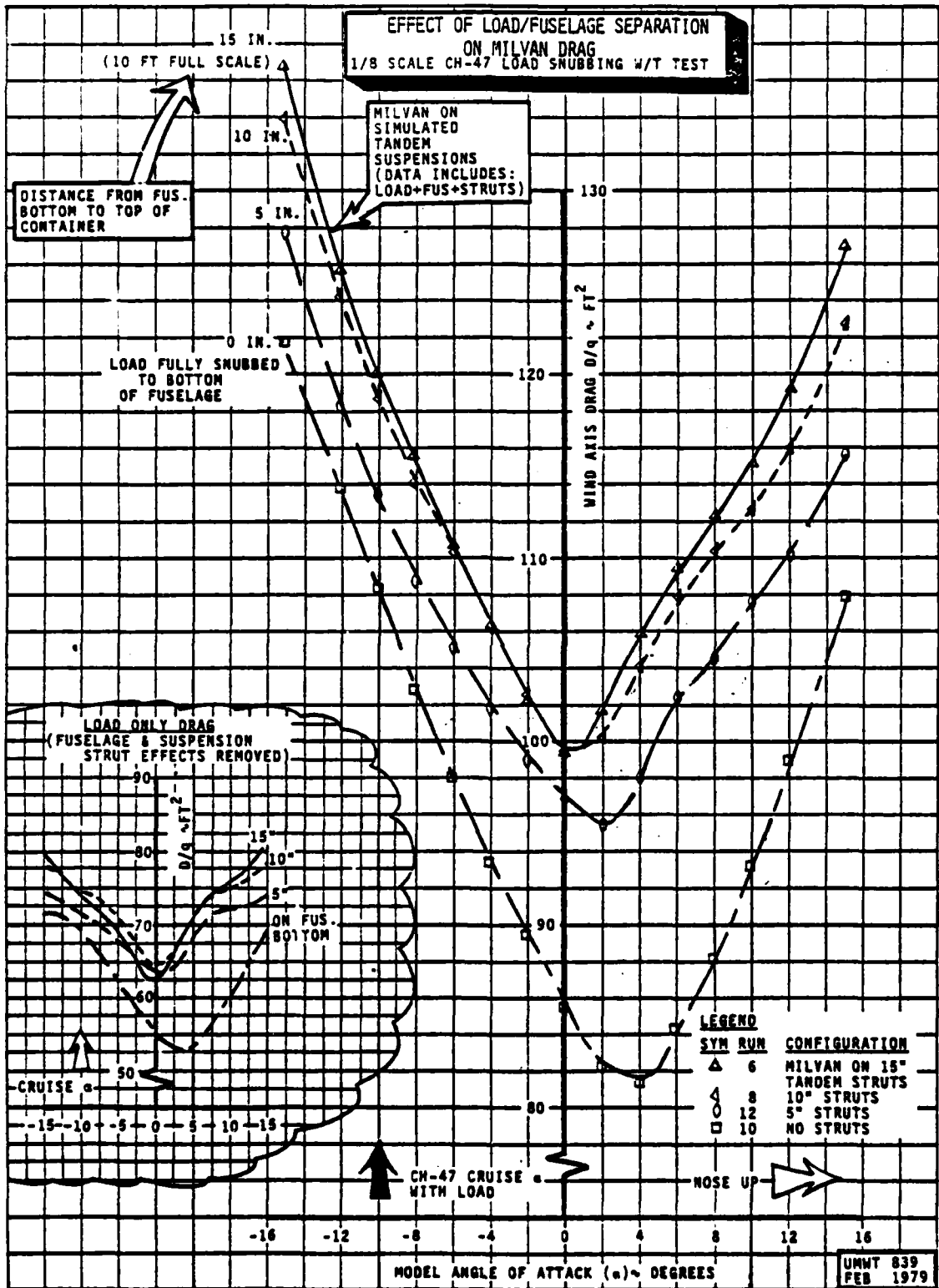

Figure 1.5 Generalized Load Snubbing Evaluation

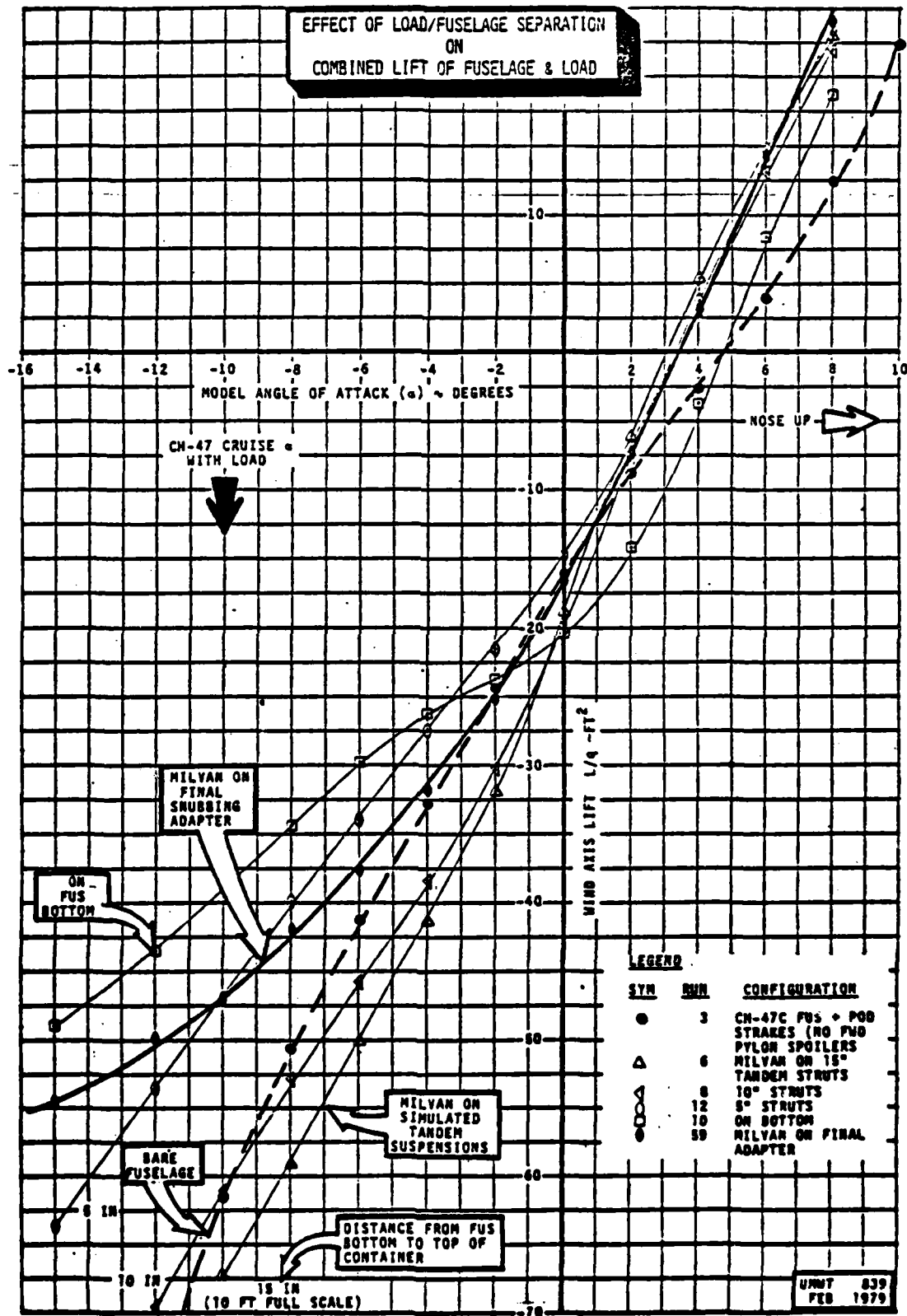

Figure 1.6 Effect of Load Snubbing on Lift

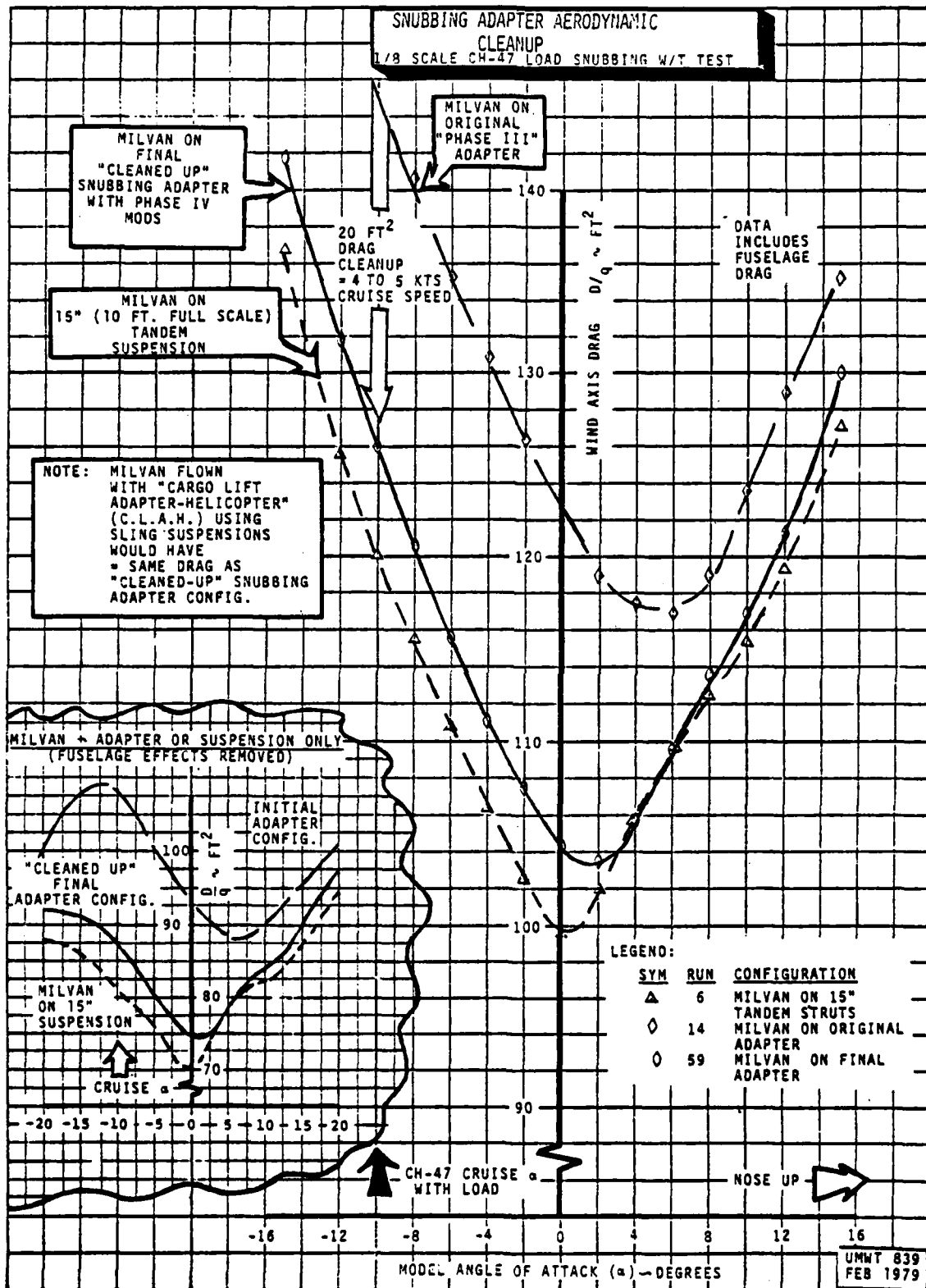

Figure 1.7 Snubbing Adapter Development

satisfactory levels of load directional stability, suspensions providing 10° nose down attitudes for the MILVAN are required.

When this nose down load increment is accounted for, and then added to the 5 to 7 ft² drag projection for the CLAH adapter, the result is a drag polar somewhat above that shown for the "final" snubbed MILVAN result. In short, flying a MILVAN snubbed will have a substantially lower drag penalty, when compared to doing the job with a 10 to 20 foot conventional sling suspension and CLAH arrangement.

Figure 1.8 presents a comparison of the cruise download contribution of snubbed and conventionally suspended MILVAN containers. The left hand plot reflects a lower download with the snubbed MILVAN (than is produced when payloads are carried internally) out to about 70 knots cruise speed. At 50 knots the conventional 10° nose down suspension has a download exceeding that of the snubbed configuration by over 900 pounds. At 110 knots (which is well within the low level terrain flight speed range), the snubbed download advantage grows to over 3800 lbs.

By adding the weights of the snubbing adapter and CLAH to their respective download curves, the potential cruise payload penalty (or required thrust increase to overcome download and empty weight delta) is derived (right hand plot). This curve clearly demonstrates the potential advantages of load snubbing.

To complete the download picture, results of carrying MILVAN containers at various heights below tandem helicopter models with powered rotors in hover (during the HLH program) were analyzed, and corrected for CH-47D configuration differences. Test results clearly showed that hover download on a snubbed container would be negligible (and might in fact reduce the overall aircraft download, because of improved vertical fuselage fineness ratio).

On the other hand, when the load was mounted away from the fuselage, at simulated suspension lengths of from 10 to 20 feet, substantial downloads were encountered. Hover download projections for the CH-47/MILVAN combination (based on these wind tunnel results) are listed below:

<u>ΔD/L (STD. SUSPENSION MINUS SNUB) ~ LBS</u>				
	<u>SUSPENSION LT.</u>	<u>10 FT</u>	<u>15 FT</u>	<u>20 FT</u>
FOR	30,000 LB A/C	440	580	700
	50,000 LB A/C	730	950	1160

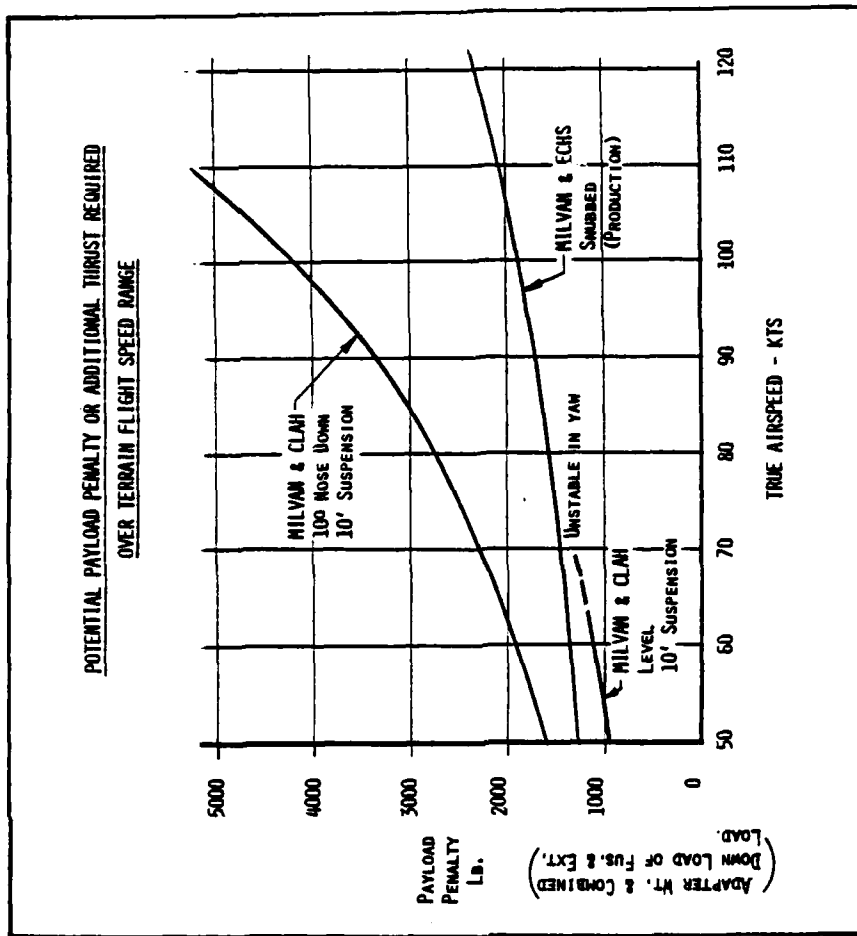
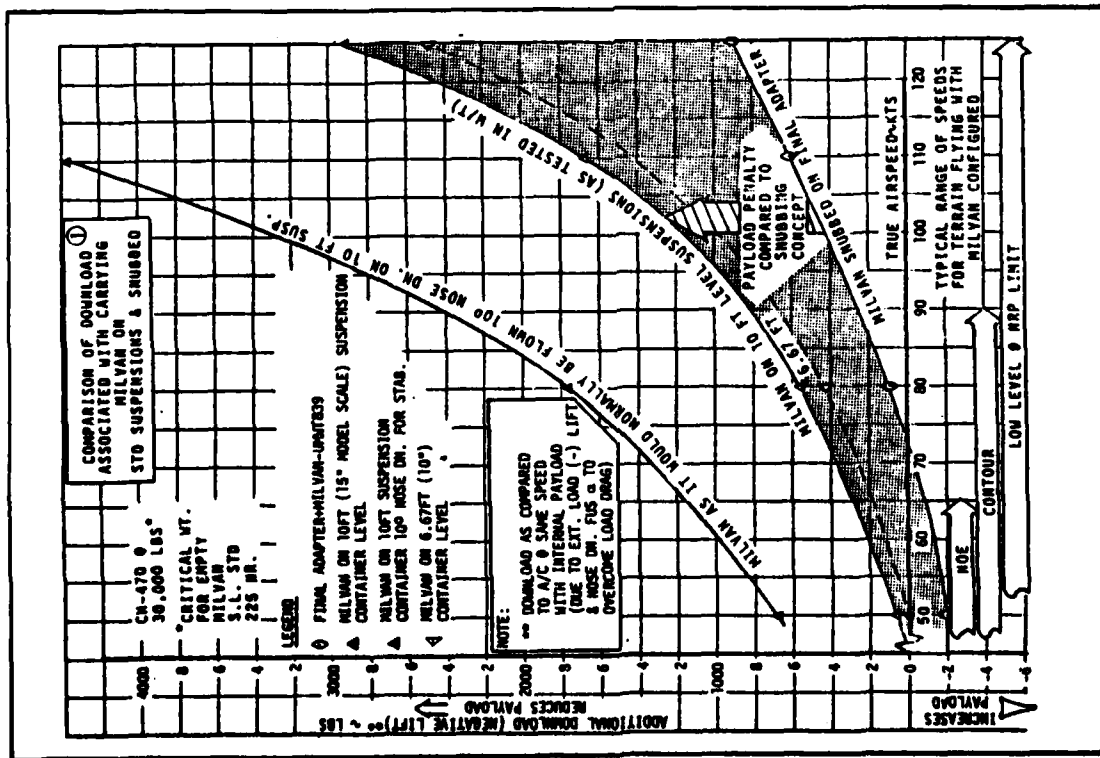

Figure 1.8 Comparison of Milvan Carried on Conventional and Snubbed Suspensions

Obvious from this table is the advantage that load snubbing carries over conventional external suspension methods. Even accounting for the (558 lb) empty weight difference between the CLAH and final snubbing system, the ECHS has a potential payload advantage for most practical flight gross weights.

This advantage can be realized for terrain flying missions, because takeoff gross weight is not predicated on O.G.E. hover capability alone, as in most mission scenerios. For terrain flight, the pilot must have O.G.E. hover power available, plus additional torque ranging from 5% upwards to over 15% (depending on the intended mission); in order to perform the various avoidance and bob or pop-up maneuvers required to evade the enemy. This extra torque available can be used to overcome additional download, during hovering as the load is being hoisted to the snubbed position.

Gondola Aerodynamics Evaluation - Figure 1.9 presents the results of an additional evaluation conducted to assess prototype Gondola aerodynamic characteristics for the Army. Since no wind tunnel data had been generated with this type of container before, the Army was interested in assessing aerodynamics for both an empty and loaded configuration, with the container mounted first on a standard suspension, and then on the snubbing adapter. Testing was accomplished with the Gondola mounted on simulated 7 foot (full scale) inverted "Vee" suspensions, and on an early snubbing adapter version.

As shown in Figure 1.9, when loaded with a simulated Forward Area Rearm and Refuel Point (FARRP) payload, the Gondola exhibits drag characteristics about the same as for a MILVAN, on similar length suspensions. In the empty configuration, Gondola drag was reduced by about 15 ft², but was still significant in the negative angle of attack cruise α range.

With the Gondola attached to the snubbing adapter, drag and lift characteristics (when loaded) were again about the same as for the MILVAN. A 15 ft² drag reduction was also produced when the FARRP payload was removed.

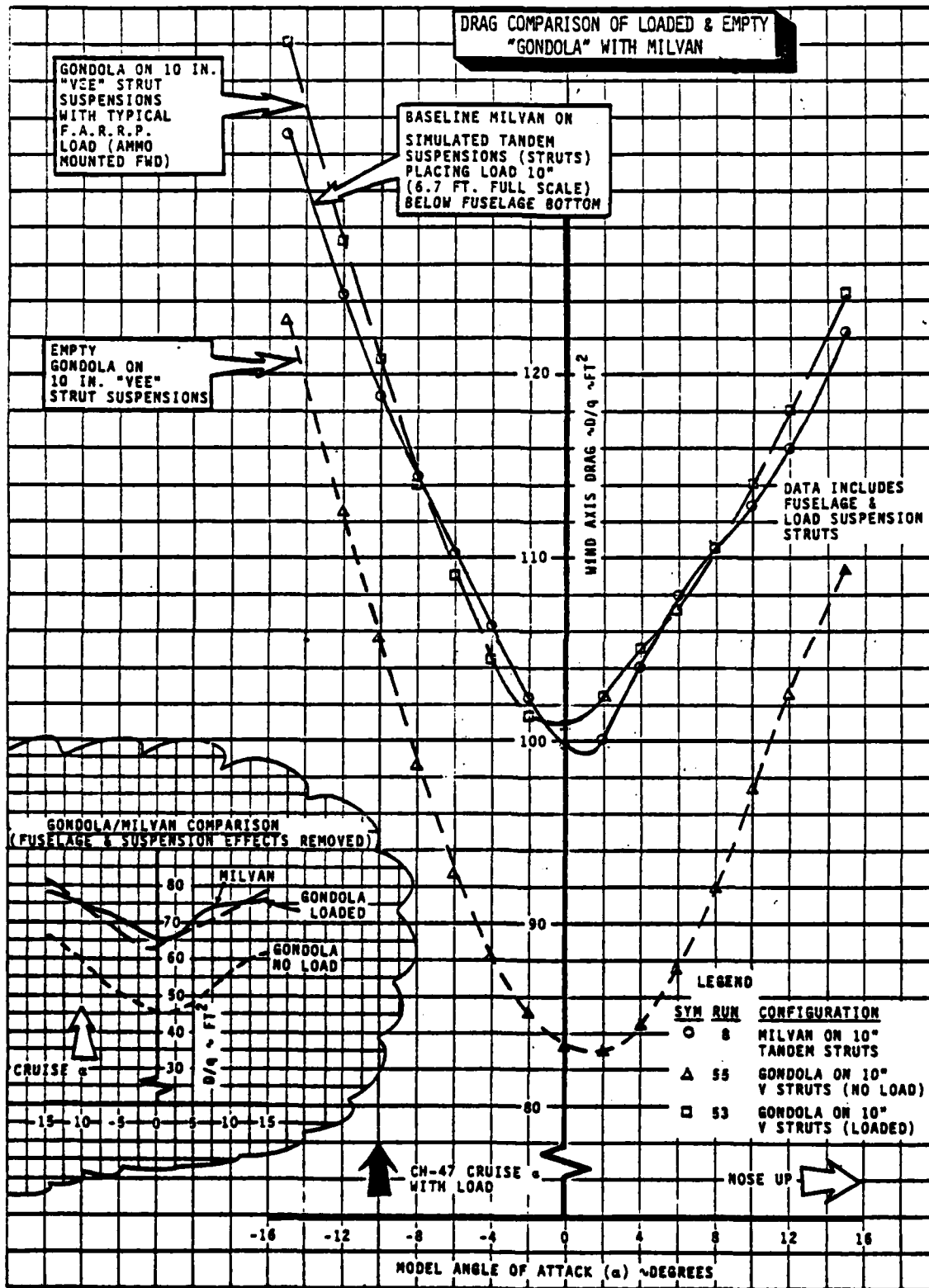

Figure 1.9 Gondola Drag

2.0 INTRODUCTION

Current U.S. Army doctrine, as defined in References 6 and 7 ("Employment of Army Aviation Units in a High Threat Environment", Field Manual 90-1; and "Terrain Flying", Field Manual 1-1), provides for employment of the CH-47 helicopter in a combat support role on mid-intensity battlefields of the future. Terrain flying with the CH-47 will be necessary, if it is to survive and complete its mission in this high threat environment. Carrying cargo externally on missions of this type is highly desirable, even if internal loading is a viable alternative. Combat vulnerability is minimized, as it reduces to seconds the forward area exposure time during cargo deposit. Productivity is enhanced when large quantities of containerized cargo are transported externally, and this can be accomplished very rapidly, with a minimum number of helicopters. If CH-47 combat support effectiveness is to be maximized, then terrain flying with external loads must also be conducted around the clock, and in all weather conditions.

CH-47 Terrain Flying Study

A cursory examination of the concept of terrain flying with external loads suggests that successful mission conduct is currently restricted by a broad spectrum of limitations. In 1977, the U.S. Army ATL-AVRADCOM laboratory sponsored an in depth study by Boeing Vertol, to quantitatively assess "Limitations of the CH-47 Helicopter in Performing Terrain Flying with External Loads" (Reference 1). The study included a comprehensive flight simulation to determine the ability of the CH-47 to perform terrain flying maneuvers, both with and without external loads, at any time of day, and in all weather conditions. Potential systems for reducing pilot workload, and for improving his ability to see terrain features in poor visibility, were looked at.

Figures 1.1 and 2.1 were taken from results of the Reference 1 terrain flight study, along with information presented in Table 2.1. The sketches shown in Figure 1.1 depict the various terrain flying maneuvers simulated in the study; along with the NOE, Contour and Low Level flight mode groupings used in the quantitative assessment of aircraft/aircrew capabilities. Roughly defined, NOE flight maneuvers were considered to be those executed close to the terrain (or masking cover), where the aircraft flew between or around obstructions while varying airspeed and flight path. Contour mode flying included going around obstructions where practical, and over those which could not be flown around; again at low altitude close to the ground. At the time the study was performed, Low Level flight was considered to be constant airspeed and altitude missions, at about 200 feet or less over obstructions.

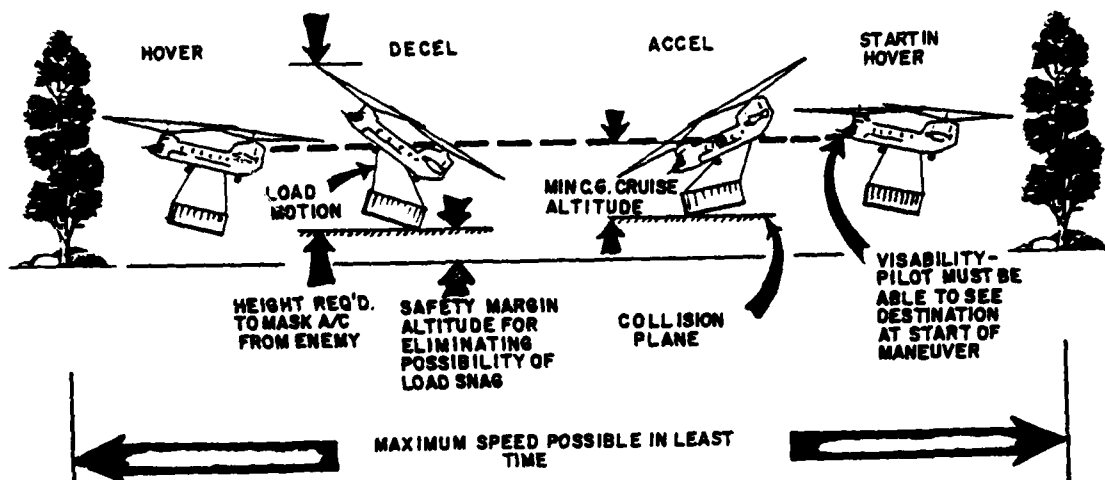

LIMITATIONS:

MANEUVERABILITY

- AIRCRAFT LOW SPEED PERFORMANCE
- LOAD MOTION (SEVERE RESTRICTION)
 - POORLY DAMPED LONGITUDINAL SWAY
 - LOAD TO FUSELAGE STRIKES OR STRUCTURAL LIMITS
- PILOT INDUCED OSCILLATIONS (PIO)
 - POTENTIAL HIGH IN NIGHT/IMC
 - ALSO EXPERIENCED IN VFR OPERATIONS

WORKLOAD (VERY HIGH)

- HANDLING QUALITIES
- LOAD MOTION
- VISIBILITY

"EXPOSURE"

MASKING (OBSTACLE HEIGHT REQUIRED) TO HIDE AIRCRAFT

- AIRCRAFT AND LOAD HEIGHT
- MANEUVER SEVERITY (LARGE ALTITUDE CHANGES)
- SAFETY MARGIN TO PREVENT LOAD SNAGS

SPEED/TIME

- AIRCRAFT MANEUVERABILITY
- DASH LENGTH
- VISIBILITY-OBSTACLE AVOIDANCE

NAVIGATION/COMMUNICATIONS

- GENERALLY NOT COMPATIBLE WITH NOE/ CONTOUR AND HIGH THREAT
 - SYSTEMS REQUIRE LINE OF SIGHT
 - JAMMABLE ETC.

(NOT EMPHASIZED IN THIS STUDY)

Figure 2.1 Forward "DASH" Maneuver

	MAP OF THE EARTH		CONTOUR		LOW LEVEL		RIGHT/IMC P/O SUSCEPTABILITY
	MASKING	MANEUVERABILITY	MASKING	MANEUVERABILITY	MASKING	SPEED	
INTERNAL LOAD BASELINE	0%	0%	0%	0%	0%	0% POWER LIMIT	NONE
STD SUSPENSION	102.5% (4)	41.2% (4)	94.5% (4)	16% (4)	251% (5)	50% (4)	HIGH WITH INCREASED LOAD WEIGHTS
STD SUSPENSION WITH LSS	110.5% (5)	0% (1)	94.5% (4)	4.7% (3)	216% (4)	30% (3)	NEGLECTIBLE
SHORT SUSPENSION	43.5% (2)	73.2% (5)	57.5% (2)	16.3% (5)	163% (3)	50% (4)	HIGH WITH INCREASED LOAD WEIGHTS
SHORT SUSPENSION WITH LSS	58.5% (3)	8.3% (3)	57.5% (2)	4% (2)	137% (2)	27% (1)	NEGLECTIBLE
SHURBED LOAD	29.6% (1)	0% (1)	26.5% (1)	2.3% (1)	89% (1)	27% (1)	NONE

% DEGRADATION FROM INTERNAL LOADED BASELINE

RANKING OF SUSPENSION SYSTEM

Table 2.1 CH-47 Terrain Flying Effectiveness (With an Empty Milvan Container)

Technical issues considered in making the quantitative maneuver evaluations required for the study are illustrated for the Forward "Dash" or Accel/Decel overview sketched in Figure 2.1. Items such as aircraft maneuverability, masking, and speed or time required to execute the maneuver were computed with the simulation math model. Under each of these major items were all of the sub-considerations which would tend to influence how well the maneuver could be performed; first with a baseline internal payload case, and then with the appropriate external cargo configuration at the same aircraft gross weight. As an example of how "maneuverability" was evaluated, things like low speed aircraft performance, load motions and tendencies for the pilot to excite the load longitudinally and cause PIO (pilot induced oscillation), were accounted for.

Two types of payloads were evaluated: a light empty MILVAN, exhibiting strong aerodynamic and weak inertial characteristics when suspended externally; and a very heavy point-mass type 155MM howitzer load. Conventional and short sling suspensions, using single point and tandem hook arrangements, were investigated, along with a group of automatic load stabilization and self hoisting load snubbing systems intended to overcome shortcomings of the sling suspended loads.

Using the terrain maneuver groupings of Figure 1.1 and individual considerations of the type pointed out in Figure 2.1, results of the MILVAN study were quantified as shown in Table 2.1. This chart compares aircraft masking and maneuverability for all three terrain flight modes, with each type of load suspension evaluated. Percentage figures given in the table indicate how much worse any given suspension was, when compared to the internal load baseline at the top of the table. Numbers in parentheses rank the various suspension alternatives, with (1) representing the best performance relative to the baseline, etc. Obvious from the table, is the superior capability of the load snubbing concept for overcoming external load suspension problems.

The three significant conclusions of the study relative to load snubbing against the aircraft were:

- It would stop all load motion and thus prevent:
 - Load/fuselage collisions
 - Longitudinal PIO potential at night or in reduced visibility
 - Increased pilot workload due to oscillation of poorly damped loads

- It would provide the potential for the best masking effectiveness possible, when carrying external cargo
- The self hoisting adapter concept suggested permits reasonable load acquisition and deposit capability, without requiring incorporation of sophisticated Automatic Flight Control System modes (in the aircraft) to accomplish the task.

Recommendations of the study (relative to cargo handling systems) were to continue development of the self-hoisting container handling device for snubbing loads to the CH-47 aircraft by:

- Conducting a preliminary design study
- Evaluating the necessity for load vibration isolation
- Establishing aerodynamic consequences of snubbing loads to the aircraft.

All three of these recommended tasks were performed under the Reference 2 contract described in this report. The principle purpose of this follow-on work has been to develop Preliminary Design Layouts and a Critical Item Development Specification (CIDS), suitable for application in detail design leading to prototype demonstration of the CH-47 load snubbing concept.

In addition to the background provided by the CH-47 Terrain Flying Study, another cargo handling effort completed at about the same time also provided useful input into the current snub load program. This was the Container Lift Adapter - Helicopter (CLAH) design development described in References 3 and 4. Several sub-system concepts utilized in the CLAH, have been carried over in design implementation of the snubbing concept.

CLAH Description

Figure 2.2 presents a general arrangement sketch of the CLAH, with two acquisition guide arms retracted for storage. The system is intended for use with aircraft tandem hook cargo systems, and will normally be flown on inverted "Vee" conventional slings. Single point suspensions are also possible for retrieval of the device.

The CLAH provides an interfacing system between the containerized payload and the aircraft suspension slings, and

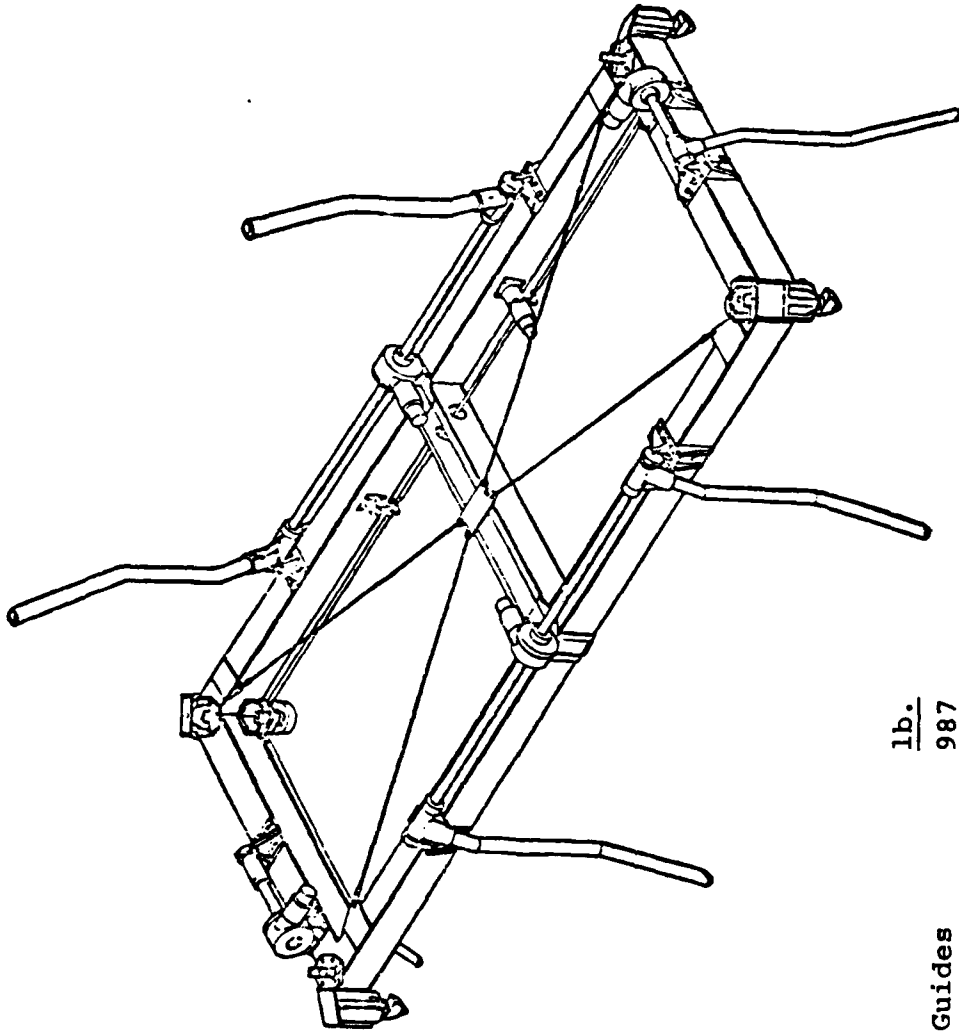

CLAH WEIGHT	lb.
With Operable Guides	987
With Fixed Guides	823
With Fixed Guides & Slings	903

Figure 2.2 Container Lift Adapter - Helicopter (CLAH) General Arrangement

performs the following functions:

- Acquisition and deposit of MILVAN/Gondola/ISO container payloads without ground handling personnel

and

- No pre-rigging of the container payload is required for use of the system.

These two capabilities of the CLAH have special significance, in light of current requirements to reduce the number of people involved with cargo handling logistics (and, instead, concentrate personnel in areas directly related to accomplishing battlefield tasks where they are critically needed). Modern battle strategy is changing from a personnel intensive approach, to one centering on the application of advanced technology and hardware.

As shown in Figure 2.2, the CLAH employs six retractable guide arms to center the device (during acquisition) on the load, for insertion of the corner mounted twistlocks. The retractable feature allows adjacent stacking of MILVANS, Gondolas, etc., and deposit or extraction of these containers from confined areas such as cargo ship holds. At the present time, two prototype CLAH units being fabricated for Army evaluation do not include the guide arm retraction feature.

In developing the snub load concept, the fixed guide arm, and corner twistlock functions of the CLAH have been incorporated in the new design. Both of these features provide a straightforward and relatively light-weight mechanical approach to the difficult task of rapidly acquiring and securing the load for transport. As in the CLAH application, the snub load corner twistlock system is intended to operate only before the load is picked up off the ground, or after it is deposited at the end of a mission. Emergency jettison of the snubbed load is effected through operation of the aircraft cargo hook system - not the twistlocks.

3.0 PHASE I - CONCEPT ANALYSIS

As described in the contract statement of work, Phase I snub load developmental activity was to include an "assessment of concept feasibility and actual design constraints, for the following areas:

- (1) Establishing need for load vibration isolation,
- (2) Methods for attachment of the load to the fuselage with minimum airframe structural modification required,
- (3) Review existing hoisting hardware for application in the Preliminary Design Phase."

All three of these tasks were successfully accomplished in Phase I. The net outcome of this concept evaluation work was selection of a system that snubs the load against the aircraft landing gear; and employs a self hoisting adapter framework for acquisition/deposit and load/aircraft interfacing, along with electrically powered 6 horsepower tandem hoists installed on 8 Hz vibration isolation spring mounts (as shown earlier in Figures 1.2 and 1.4).

Highlights of the selection process are described in this section of the report. Although the initial evaluation of candidate concepts and vibration isolation requirement analysis studies took place at essentially the same time, concept evaluation is described first, followed by the vibration assessment. This section of the report concludes with a description of the hoist preliminary design work, accomplished to provide background information for a summary of existing aircraft hoist hardware.

3.1 CONCEPT EVALUATION AND SELECTION

Using the load snubbing approach developed during the Reference 1 CH-47 Terrain Flying Study as a starting point, a number of different ways to interface the load and airframe in the "snubbed" configuration were conceived of, and each was then evaluated quantitatively to select the best system for further design development. Very early in the conceptual phase of this snubbing design synthesis, it became apparent that load snubbing, per se, was not the problem - the real difficulty with any system of this type (intended for deployment with the CH-47) was load acquisition/deposit; which was to be accomplished without assistance of ground crew personnel, or pre-rigging of the cargo in any way.

System Alternatives

Two possible approaches to the load acquisition/deposit problem were to either:

- Utilize a CLAH like adapter framework with guide arms for mechanically centering on, and acquiring the load for twistlock insertion (as described in Section 2)

or

- Modify the CH-47D mechanical and automatic flight control (AFCS) systems with linear velocity control functions (similar to those developed for the HLH helicopter, and flight test demonstrated on the Model 347 aircraft) to substantially improve CH-47 low speed flight precision and hovering accuracy

- and at the same time -

Provide mechanical capture capability on the aircraft, to perform final guidance and locking functions for attaching the load to the airframe.

Although both of these approaches appear to be technically feasible (based on 347/HLH flight test results), the second was eliminated from consideration because of extensive modifications required to the CH-47 control system and airframe to make the system work. These modifications violate contractual requirements for minimal aircraft change. As a point of interest, flight test results from the HLH program (described in Reference 8) indicated hovering accuracies with 10 knot steady winds gusting to 24 knots (which are reasonably low speeds when considering "all-weather" load acquisition requirements) to be in the following range:

- With SCAS Only 4 FT. CEP*
- With Low Speed Velocity Control using IMU 1 1/2 FT. CEP
- With Precision Hover (PHS) Velocity, Control Mode Engaged 4 IN. CEP

*Circular Error Probability

These hover accuracy figures indicate that an aircraft using SCAS functions alone (similar to those in the CH-47D AFCS) would only be capable of hovering inside a circle with a four foot radius during load acquisition. Linear velocity control improves this substantially, but even with a PHS installed,

additional capability in any load snubbing and acquisition system would have to be provided, because the CEP hover accuracy exceeds the size of the corner rigging holes in the container by a factor or two.

The "capture" capability of a CLAH like adapter concept employing mechanical guide arms extending downward and outward, allows the pilot to "bomb" the load with the adapter, anytime the crew chief tells him he is approximately centered over the container. By lowering collective pitch, the adapter settles onto the load, centers itself for twistlock insertion automatically, and the suspension cables then become slack.

In this configuration with cables slacked off, the aircraft is essentially "free" from the constraint of the load during the critical hookup and locking process. This freedom in the horizontal and vertical directions (although limited by suspension cable length) is essential because of the hover accuracies pointed out above. Alternative systems rigidly connecting or pinning the aircraft and load would make the acquisition process in winds a virtual impossibility; not to mention the problem associated with aircraft control once it was attached to a heavy stationary load on the ground.

Concept Evaluation

With the adapter/guide arm approach to load acquisition selected, eight separate conceptual methods for snubbing the load to the bottom of the aircraft were devised. Figures 3.1, 3.2, and 3.3 present sketches and brief descriptions of these eight concepts, and Table 3.1 lists the salient features of each used in judging which was best for follow-on preliminary design. Among the items considered were:

- Guidance for load acquisition
- Load/adapter retention
- Method of Vibration Isolation
- Fail-safe features
- Structural load reaction against the airframe
- Emergency release approach
- Aircraft rework required for system interfacing
- Logistics

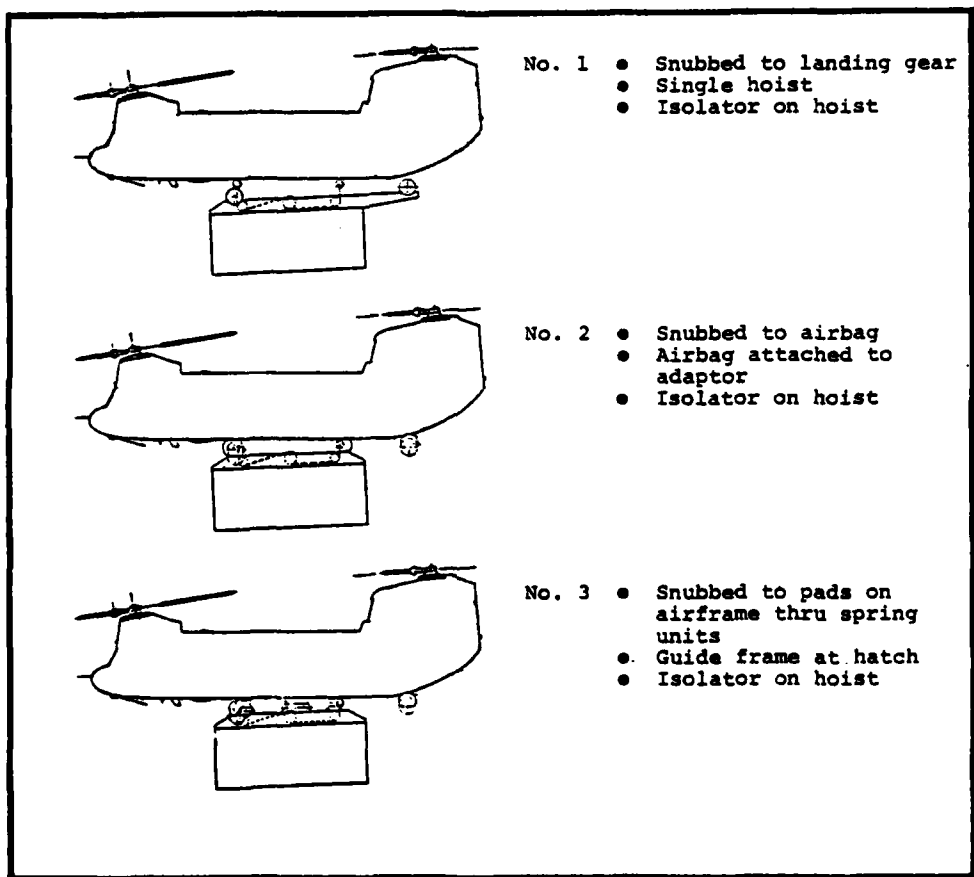

Figure 3.1 Configurations Maintaining Tension on Cables

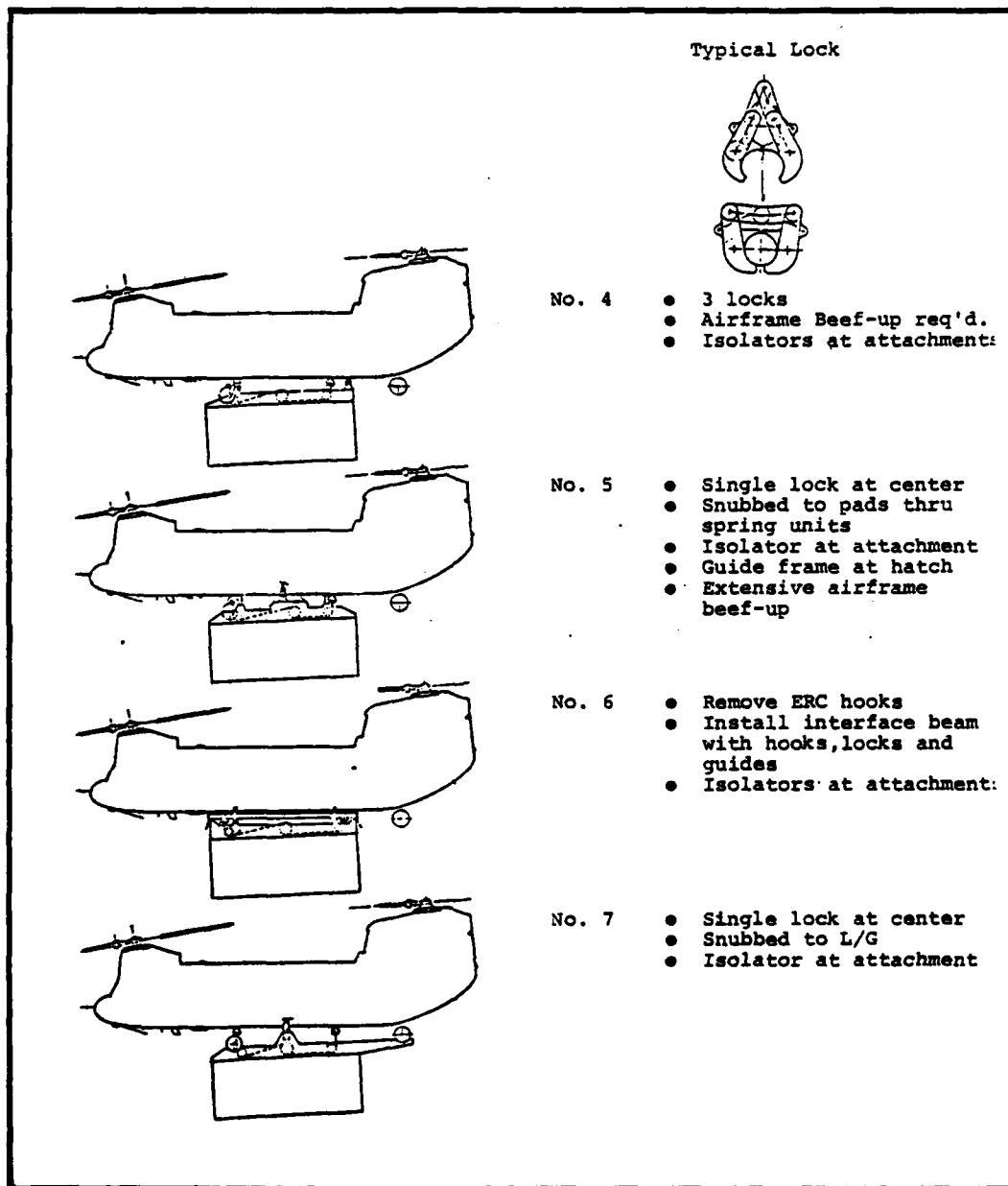

Figure 3.2 Configurations Locking to Fuselage
No Tension on Cables

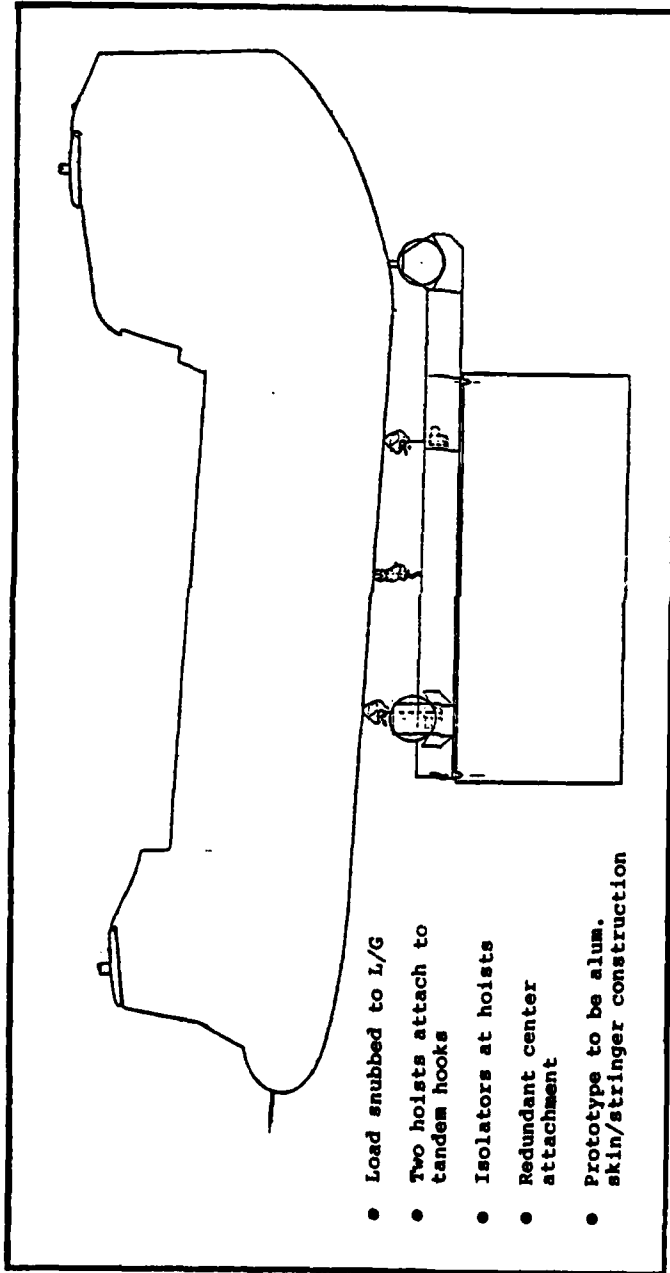

Figure 3.3 No. 8 Selected Configuration

LOAD SNUBBING CONCEPT EVALUATION

CONCEPT	1	2	3	4	5	6	7	8
GUIDANCE	BUILT INTO FRAME-GUIDE TO L.G.	MINIMUM GUIDANCE REQ'D TO CLEAR L.G.	GUIDE FRAME INSTALLED IN MATCH	PROBABLY GUIDE FRAME SIMILAR TO 3 POSSIBLY LOCAL GUIDES AT LOCKS	GUIDE FRAME INSTALLED IN MATCH	GUIDE CORNERS	BUILT INTO FRAME - GUIDE TO L.G.	BUILT INTO FRAME - GUIDE TO L.G.
RETENTION	MAINTAIN TENSION ON CABLES - LOCK HOIST	MAINTAIN TENSION ON CABLES - LOCK HOIST	MAINTAIN TENSION ON CABLES - LOCK HOIST	3 LOCKS ON A/F 0 TENSION KEEP HOIST UNLOCKED	SINGLE LOCK AT CENTER HOIST LOCATION 0 REMOVE TENSION FROM CABLE	3 LOCKS ON BEAM 0 TENSION & KEEP HOIST UNLOCKED	SINGLE LOCK AT CENTER HOIST LOCATION 0 TENSION ON CABLES	MAINTAIN TENSION ON CABLES
ISOLATION	COMPRESS GEAR & USE DELETTINE PLUS ISOLATOR 0 HOIST	INVESTIGATE AIR BAG CHARACTERISTICS	ISOLATOR ON HOIST	ISOLATORS AT LOCK ATTACHMENT	ISOLATOR AT LOCK	ISOLATORS AT LOCK ATTACHMENT	ISOLATOR AT LOCK	PARTIAL L.G. PLUS ISOLATORS AT HOISTS
FAIL SAFE	SINGLE HOOK OPEN OR CABLE FAILURE PROBLEM	SINGLE HOOK OPEN OR CABLE FAILURE PROBLEM	SINGLE HOOK OPEN OR CABLE FAILURE PROBLEM	LOCK RELEASES INTER-CONNECTED GOOD	SINGLE ATTACHMENT GOOD	LOCK RELEASES INTER-CONNECTED	SINGLE ATTACH. GOOD	CENTER HOOK ATTACHMENT W/IDE STIMPLE FAILURE SHEET
VERT LONG LAY REACTION LATCH TRANSMISSION ROLL	CABLES L/G L/G-SIDELOAD TEN CABLES/COMP L/G SIDELOAD L.G. TEN CABLES/COMP L/G	CABLES - TEN CABLES/COMP L/G SIDELOAD L.G. TEN CABLES/COMP L/G	CABLES GUIDE ARMS CABLES/PADS CABLES/PADS CABLES/PADS	LOCKS	LOCK GUIDE FRAME LOCK/PAD LOCK/PAD LOCK/PAD	LOCKS	LOCK L.G. LOCK/L.G. SIDELOAD L.G. LOCK/L.G.	CABLES L.G. L.G. SIDELOAD TEN CABLES/L.G. SIDELOAD L.G. TEN CABLES/L.G.
EMERGENCY RELEASE	RELEASE HOOKS	RELEASE HOOKS	RELEASE HOOKS	OPEN LOCKS (CABLES CAN REEL OFF DRUM)	OPEN LOCK (CABLES CAN REEL OFF DRUM)	OPEN LOCKS (CABLES CAN REEL OFF DRUM)	OPEN LOCK (CABLES REEL OFF DRUM)	RELEASE THREE HOOKS
URGENT REMOVAL	NIL	PROBABLY NIL	MINIMAL-TEFLON PADS AT SPRING POSITION - ATTACHMENT FOR GUIDE FRAME	EXTENSIVE BACK-UP AT THREE LOCK LOCATIONS	MINIMAL - AS 3	MINIMAL-REMOVE EBC HOOKS, ADD TEFLON PADS	MINIMAL (REPLACE CENTER HOOK WITH LOCK)	NIL
LOGISTICS	DEVICE ONLY	DEVICE ONLY	DEVICE + GUIDE FRAME + REMOVAL	DEVICE + GUIDE FRAME + REMOVAL	DEVICE + GUIDE FRAME + REPLACE CENTER HOOK + REMOVAL	DEVICE + INTER-FACE BEAM + REMOVAL	DEVICE + REPLACE HOOK	DEVICE ONLY

Table 3.1 System Features Considered in Load Snubbing Concept Selection

Table 3.2 presents numerical results of the Phase I candidate selection scoring task, which clearly identified Configuration 8 (snubbing against the aircraft landing gear while maintaining load on the suspension cables) as being superior to the other seven concepts. Weighting factors selected for the scoring were chosen on the basis of contractual guidelines requiring minimum aircraft rework, concept simplicity, etc.. It should be pointed out that configurations maintaining load on the cables during snubbed flight were superior to those which locked the load to the aircraft; because the latter required redundant load path structure to either support the load, or to react its motion through snubbing pads, springs etc.. This extra structure obviously incurs additional weight penalty, which should be avoided if possible.

Before describing the vibration isolation analysis, it is important to point out why the single point center suspension (Configuration 7) was rejected. This approach at first seemed attractive because of its simplicity; i.e. support the entire load on the center cargo hook, and react against the gear for snubbing isolation. Unfortunately the idea has two flaws, one of which made the concept impractical for further consideration.

First, insufficient stiffness is present on the aircraft backup structure around the center track to provide spring rates necessary for 8 Hz load vibration isolation (described later). The second problem is that, in the event of an inadvertent center hook operation, the load reverts to support by the hoists, and this would necessitate installation of a braking system for these devices not otherwise required.

The better solution to load retention is incorporated in Configuration 8 (Figure 3.3), which provides a redundant center hook attachment that only carries load when either the forward or aft hook (or hoist) suspension fails. Should such a failure occur, the remaining suspension and center attachment retain the load, whereupon the mission may proceed (at reduced speed and maneuver capability), or a precautionary deposit of the load can be effected by the aircraft commander if desired.

3.2 VIBRATION ISOLATION ANALYSIS

Criteria

Dynamics criteria for vibration isolation of snubbed loads considers three principal problem areas:

- Potential effect of 3/rev fuselage vibration
- Pilot induced oscillation (potential for "vertical-bounce")

QUANTITATIVE
CONFIGURATION COMPARISON











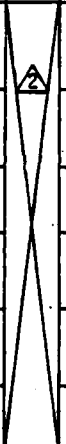

CONFIGURATION		1	2	3	4	5	6	7		8		
								1	3 			
EVALUATION CRITERIA	WT FAC											
ACFT REWORK	40	40		10	0		20		35	40		
SYSTEM SIMPLICITY	15	15			5		5		0		10	12
FAIL SAFE	15	0 		0 	10				10		15	15
COST	10	10			3		0		0		8	10
WEIGHT	10	0			10		5		0		0	0
LOGISTICS/ OPERATIONS	10	10			5		5		0		3	10
TOTAL	100	75		33	25	30		71	87			
<p> REQUIRED AIR PRESSURE OF 200 PSI IMPRACTICAL.</p> <p> SINGLE ATTACHMENT STIFFNESS TOO LOW FOR ISOLATION REQUIREMENTS.</p> <p> POOR FAIL SAFE CHARACTERISTICS MAY BE CAUSE FOR REJECTION.</p> <p> PROBLEMS OF STRUCTURAL REDUNDANCY COULD BE CAUSE FOR REJECTION.</p>												

Table 3.2 Load Snubbing Concept Evaluation

- Static deflection of the isolation system under load.

The 3/rev fuselage vibration for the CH-47 aircraft is insensitive to gross weight change with internal ballast, with fuel burnoff or with external sling loads. For internal ballast, this has been provided (in aircraft through the C Model) by an isolated cargo floor utilizing constant frequency rubber mounts that maintain a suspension frequency near 8 Hz. This causes the natural modes of the aircraft near 3/rev (11.25 Hz) to be insensitive to ballast variations, and results in low 3/rev vibration levels similar to the empty aircraft. The same isolation technique is employed for the isolated fuel tank system. With external sling loads, the ballast is dynamically isolated from the fuselage by the softness of the nylon strap sling system.

Pilot-induced oscillations at 1/rev are no longer a problem as they were in early CH-47 aircraft, because of incorporation of the ECP-410R3 thrust control system which alleviates external load vertical bounce. The CH-47D AFCS provides similar protection from this phenomena. However, external load natural frequencies should still be sufficiently removed from 1/rev vibrations, to avoid amplification where possible.

Static deflections of snubbed external loads must be relatively small in order to maintain the snubbed position during both steady 1.0g flight, and while performing terrain flight maneuvers close to the ground. The following table shows the frequency ranges required to avoid amplification of 1/rev and 3/rev vibrations, and the attendant static deflections.

	<u>FREQ. AT</u> <u>225 RPM</u>	<u>REQ'D FREQ</u> <u>FOR ISOLATION</u>	<u>STATIC</u> <u>DEFLECTION</u>
1/Rev	3.75 Hz	<2.65 Hz	1.39 Inch
1/Rev	3.75 Hz	>5.25 Hz	.36 Inch
3/Rev	11.25 Hz	<7.9 Hz	.16 Inch

Obviously, the lower frequency isolation schemes would experience large deflections, while the 7.9 Hz isolation would have manageable motions.

In summary, the following dynamic criteria were established for CH-47 snubbed external loads:

- Isolation is required to prevent degradation of the cockpit/cabin environment, which would substantially increase aircrew workload and decrease comfort

- Isolation frequency placement to be 8 Hz
- Vertical and pitch modal isolation is prime
- To maintain constant 8 Hz, non-linear isolator springs are required, as payloads are varied between 5,000 lbs and 25,000 lbs.
- Small static deflections are required (.16 inch with 8 Hz isolation).

Configuration Analysis

Dynamic analysis of a range of snubbed load weights and systems was conducted. The analysis technique employed was to convert the helicopter-suspension-external load system to a single mass system by calculating an equivalent effective mass (effective mass is equal to the product of the helicopter and external load masses divided by the sum of their masses). Then the effective mass was employed in a six degree of freedom rigid body on springs WATFOR analysis, to calculate the suspension frequencies. Weights and inertias of the CH-47C helicopter were used in the program, but these are quite similar to CH-47D values provided after the analysis was completed, and thus the results are considered to be valid for the preliminary design.

All eight candidate snubbed load suspension schemes were investigated, but in the interest of economy, only those most promising were thoroughly analyzed to derive isolator requirements, etc..

The first cut requirement of the load suspension system is to provide a vertical suspension frequency of 8 Hz. To accomplish this a total vertical spring rate of 27,500 lb/in is required for a 5,000 lb load, and 84,500 lb/in for a 25,000 lb load. The cargo hooks have vertical stiffnesses of 27,400 lb/in for the center hook, 40,500 lb/in for the forward tandem hook, and 36,800 lb/in for the aft tandem hook. Any suspension employing only the center hook would be too soft, and therefore not acceptable as described earlier. A configuration using the forward and aft hooks would be stiff enough with inclusion of the snubber stiffness; and obviously, a configuration employing all three hooks would have adequate backup structural stiffness to permit placing the vertical and pitch frequencies at 8 Hz.

To maintain a constant 8 Hz frequency placement over the 5,000 lb to 25,000 lb load range, non-linear springs are required. They must have the characteristic of increased stiffness with increased load weight, and the amount of the static load must prescribe the dynamic stiffness. The most practical solution

is to have the suspension system employ snubbers with relatively low constant stiffness, while the load supports contribute the majority of the stiffness that is non-linear with load.

A fairly low stiffness snubber is already available on the CH-47 helicopter in its landing gear. Over the first several thousand pounds of strut load, each forward gear has an equivalent stiffness of 1700 lb/in, and the aft 1300 lb/in. This stiffness is provided by the combination of a bottoming spring installed in the oleo strut, and by the spring rate of the inflated tires. Figures 3.4 and 3.5 (from Reference 9) relate oleo strut and tire deflection under load to spring rate; which can be derived for the series mounted (coupled) tire and strut combination, by summing the inverse of the spring rates for each.

A snubbing scheme employing all four landing gear would have the relatively low 6,000 lb/in stiffness desired. Two concepts utilizing the landing gear springs in parallel with the hoist and backup structure springs, (along with the tandem hooks for support), are configurations 1 and 8 (Figures 3.1-3.3). When Configuration 7 is supported on all three hooks simultaneously, and is then snubbed against the gear, this system also has the potential for providing the isolation required. Because Configuration 6 (with an interfacing framework between the aircraft and the adapter) was also considered as a possible solution; it too was analyzed to develop requirements for a vibration isolation system. Table 3.3 presents a schematic outline of how the three spring network (gear, hoist mount, and backup structure) operates to generate vertical isolation required for snubbing (using the aft hoist and gear assembly, and a 5000 lb. load as an example). At the bottom of this table are summarized the principal results of isolation analysis work conducted for candidate configurations considered worthy of further evaluation.

Figure 3.6 presents analytical results for Configuration 1 and 8. The upper plot shows the frequency placement of each mode with load variation, when no isolation is employed. The prime natural modes, vertical and pitch, are above 3/rev at light load weights, and pass thru 3/rev at a load weight of 10,000 lb. At 25,000 lb both modes are near 8 Hz which is the desired frequency placement. In order to lower the lighter load weight frequencies to 8 Hz, isolation is needed as shown in the lower plot for each hoist support. With cargo hook isolators having the characteristics shown, it is possible to get satisfactory frequency placement as indicated at the bottom of the plot. The vertical mode has a constant frequency of 8 Hz over the load range, while the pitch mode is 10 Hz at the lightest weight, and moves down to 8 Hz at the greatest weight.

Figure 3.7 shows the analysis results for Configuration 7

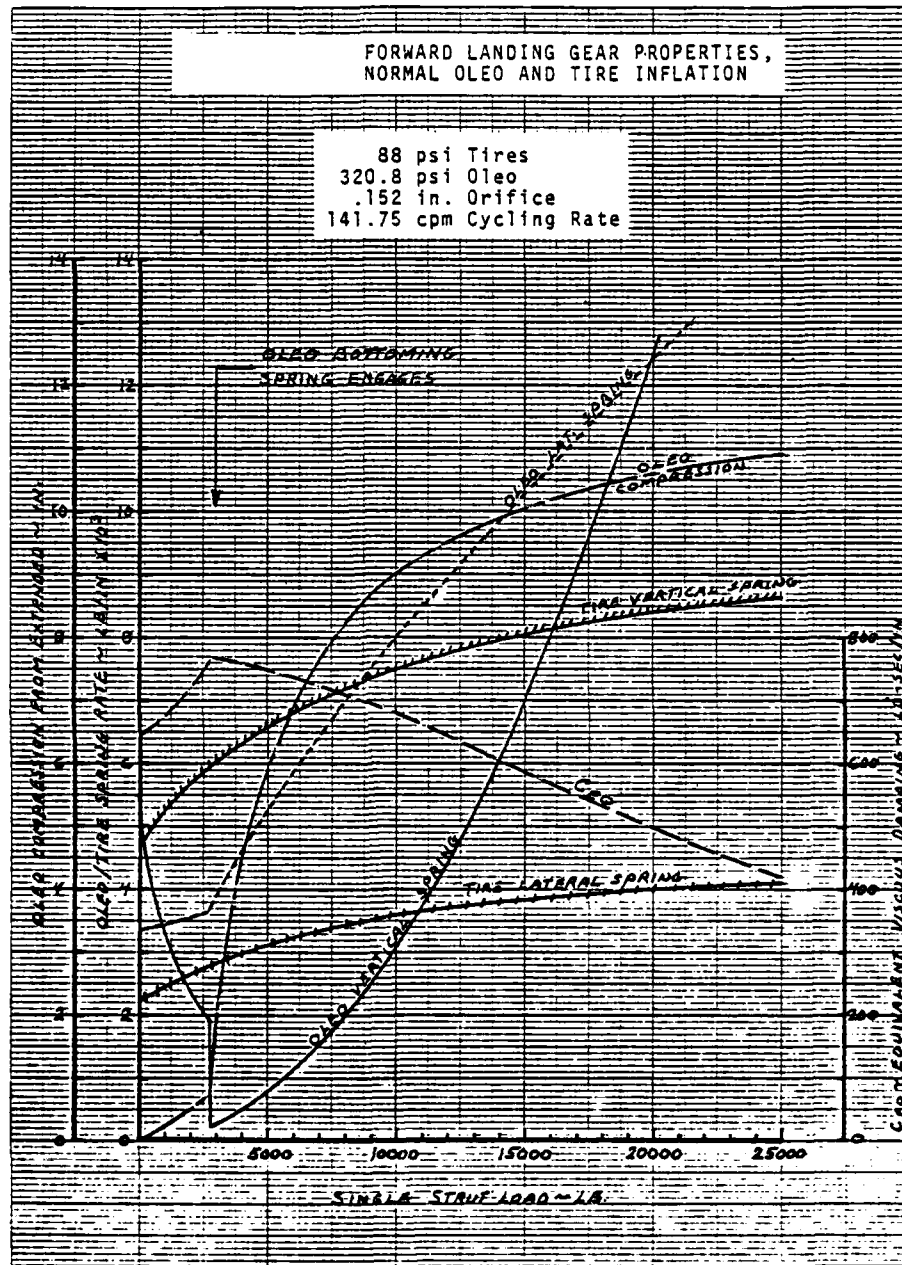

Figure 3.4 Forward Landing Gear Properties

(Data from Reference 9 for YCH-47D)

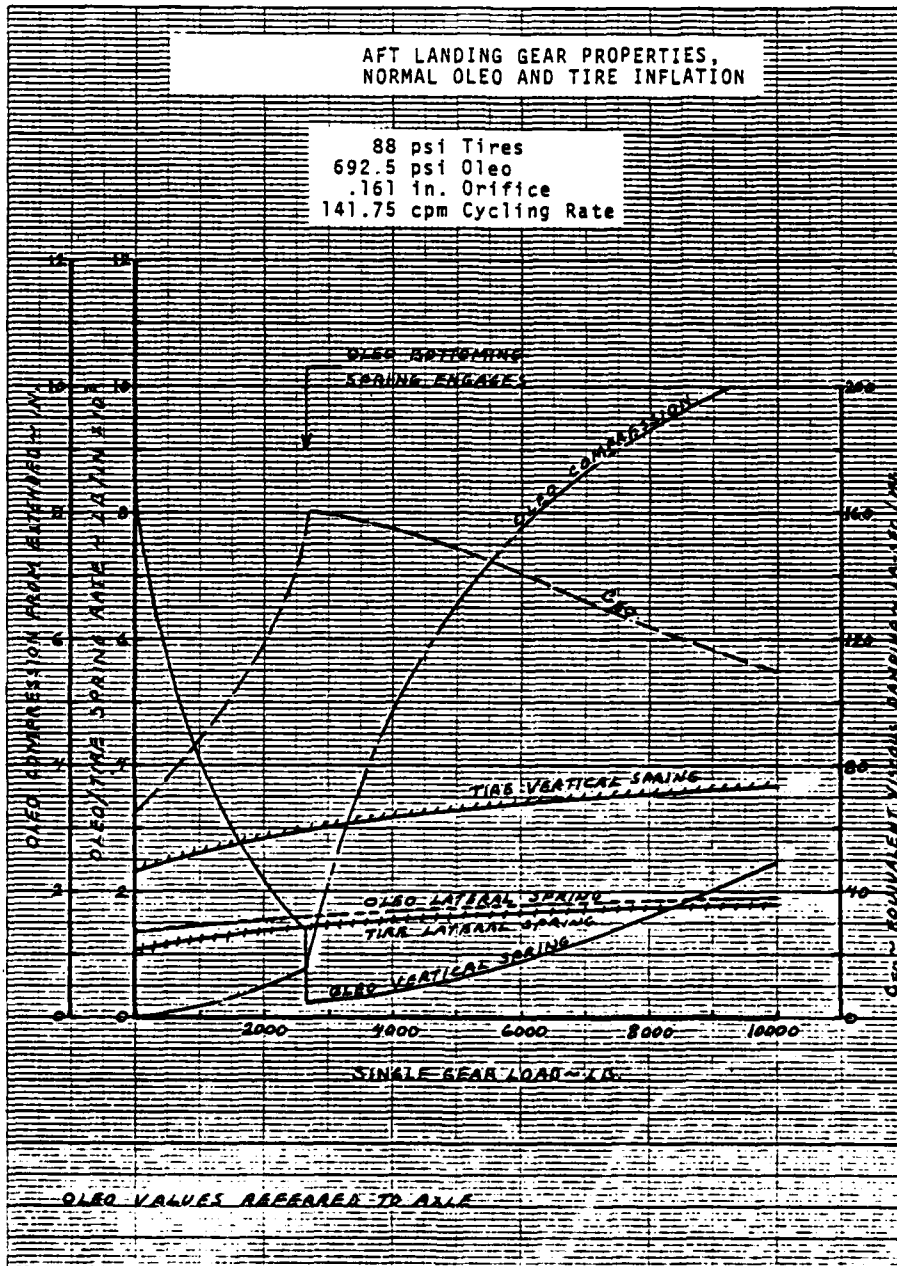

Figure 3.5 Aft Landing Gear Properties

(Data from Reference 9 for YCH-47D)

APPROACH TO ISOLATION SOLUTION

- PROVIDE CONSTANT LOW STIFFNESS ELEMENT FOR SNUBBING (I.E., GEAR AT 6,000 LB/IN TOTAL)
- COMBINE CONSTANT AIRFRAME STIFFNESS AT EACH SUPPORT (HOOK), WITH NON-LINEAR VARIABLE STIFFNESS ISOLATOR TO ACCOUNT FOR LOAD CHANGES.

• EXAMPLE:

FOR 5K LOAD

SOFT SPRING
AFT GEAR
STIFFNESS
2.6K/IN
(BOTH GEAR COMBINED)

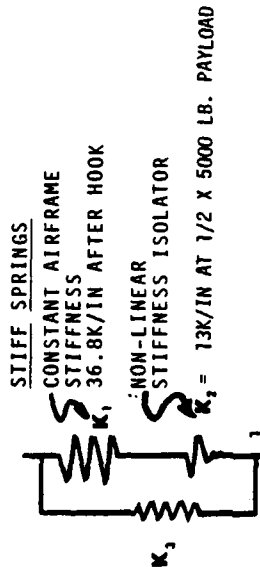

$$\begin{aligned}
 K_{TOT} &= K_3 + K_{SUP} \\
 &= 2.6K/IN + 9.6K/IN \\
 &= 1/2 \text{ REQUIRED STIFFNESS} \\
 &\text{FOR 5000 LB. LOAD}
 \end{aligned}$$

RESULTS OF CANDIDATE CONCEPT ANALYSIS

CONFIGURATIONS 1, 8 (2 HOOK GEAR SNUBBING) ANALYZED/O.K. SEE ATTACHED FIGURES
 CONFIGURATION 6, SNUB AGAINST INTERFACE FRAME/O.K. CONFIGURATIONS 3, 4 SIMILAR
 CONFIGURATION 2, NO GOOD. 200 PSI IN AIRBAG REQ.
 CONFIGURATION 7, (3) HOOKS (POOR - REDUNDANT LOAD PATH)
 CONFIGURATIONS 7, 5, (1) HOOK (NO GOOD - INADEQUATE STIFFNESS)

TABLE 3.3 ISOLATOR CONSIDERATIONS

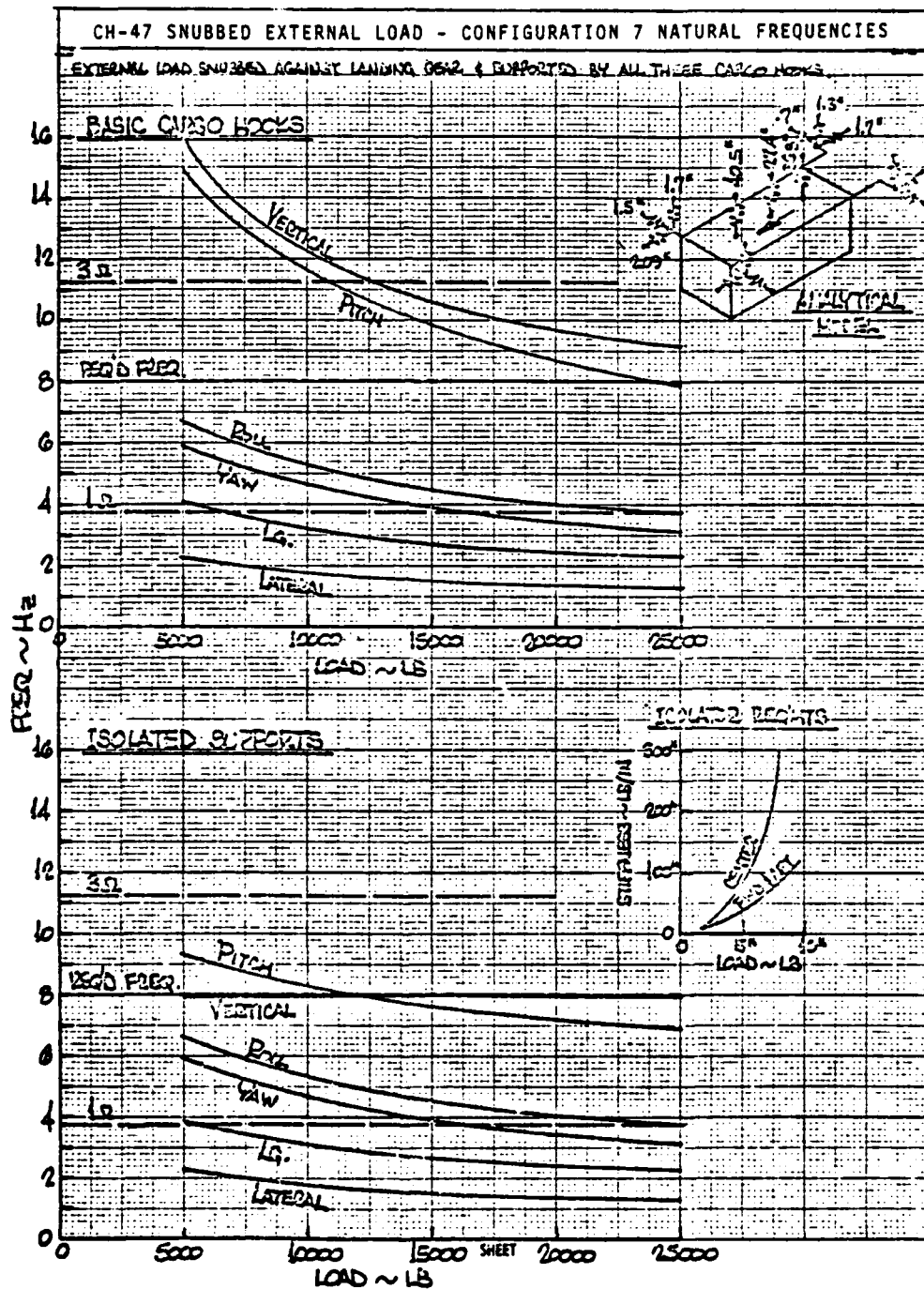

Figure 3.7 Effect of Support Isolation on Frequency Placement for Snubbed Load Configuration 7 (Three Hook Redundant)

with three load supports. In the unisolated case the results are similar to Configuration 1, except that the vertical mode has a slightly higher frequency due to the additional stiffness of the center cargo hook. Again with the isolator characteristics shown, it is possible to place the vertical and pitch modes in close proximity to the required 8 Hz. Since Configurations 1, 7, and 8 all employ forward and aft cargo hook isolators of similar stiffness, the isolator may be incorporated in either a common or tandem winch system as desired. One drawback of the three hook concept is that the redundancy of support makes load sharing difficult and troublesome. If, for example, the majority of the load was being carried on the center hook, the frequency placement would be lower than required.

Figure 3.8 contains the analysis results for Configuration 6, where the load is supported by two hooks on the interface framework, and is held against two snubbers located on either side of the forward cargo hook. A soft stiffness of 500 lb/in in all directions was arbitrarily selected for each snubber. Again, in the unisolated case the vertical and pitch modes start above 3/rev at light weight and move to just below 8 Hz at heavy weight. With a non-linear type of isolation, it is possible to place the vertical and pitch modes near 8 Hz over the entire load spectrum.

Conclusions and Recommendations of the Isolation Study

- Isolation of snubbed external loads is required. Vertical and pitch natural frequency placement should be 8 Hz.
- External load support must utilize either two or three cargo hook arrangements. One hook is too soft. Three hooks are redundant and complicate load distribution. Two hooks are the best.
- Any low stiffness snubbing arrangement with a total spring rate of 6000 lb/in or less will permit proper frequency placement. The landing gear could provide such a snubber.
- The load-support isolators must have a non-linear spring rate, which increases stiffness with increasing static load. With a two-hook arrangement one isolator could be integrated into the common hoist if this configuration is preferred to the dual hoist system discussed earlier. A three-hook configuration would require an additional isolator for the center hook.

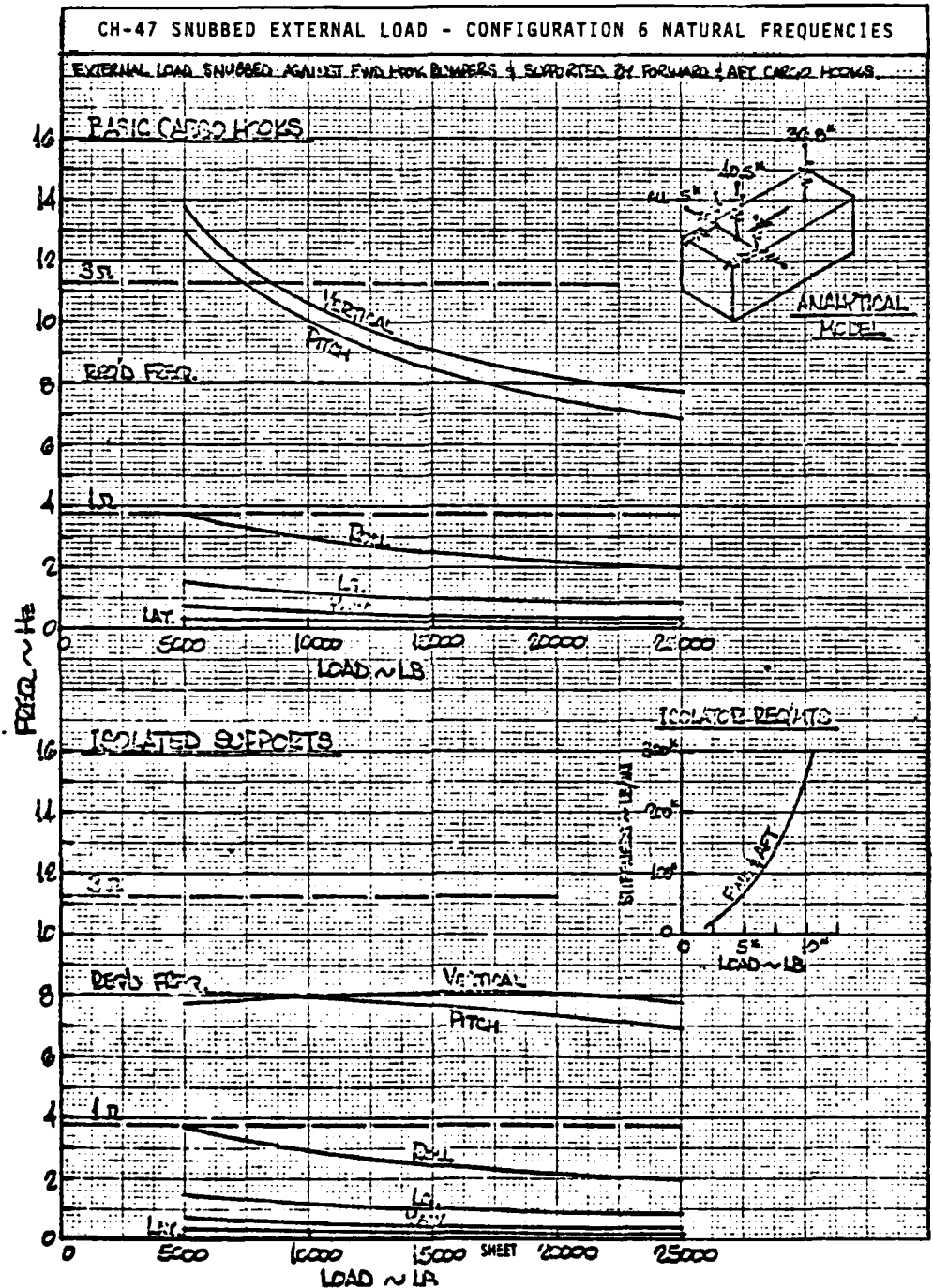

Figure 3.8 Effect of Support Isolation on Frequency Placement for Snubbed Load Configuration 6 (Tandem Hook + Bumpers on Frame)

Effect of Load Vibration on Landing Gear Oleo Life

To ensure that the landing gear snubbing concept would not reduce MTBO rates, or cause premature failure of oleo strut seals, an investigation of potential strut vibratory motions was conducted. Results are shown in Figure 3.9, which depicts vibratory movement of the gear axle for various flight regimes with a snubbed load. The tire is considered to be rigid, as is the adapter framework.

Typical oscillation amplitudes of between .006 and .05 inches are predicted to exist, if all rigid body load motion is transferred through the tire into the strut. Motions as small as these for oleo struts or hydraulic actuator pistons have the potential for causing rolling rather than sliding motion of "O" ring type seals; with a concurrent reduction in overall life. The smaller the amplitude of motion, the more likely round seals are to roll in their mounts.

At the present time, it is expected that the combination of a compliant tire tread, along with the flexibility built into the adapter structure itself will prevent the oleo seals from becoming a problem, when the load is snubbed. Nevertheless, small amplitude vibratory endurance bench testing of an oleo strut and tire system should be considered in the overall developmental program to ensure adequate seal life (prior to any flight testing of the concept). Once in flight test, oleo seals should be periodically monitored for wear. Should unexpected problems arise, potential solutions are available with improved actuator/strut seal technology demonstrated in recent years. Cylindrical rather than "O" ring type seals with special retention hardware to prevent rolling are readily available, and could be installed in the gear if necessary.

3.3 PRELIMINARY HOIST CONCEPT DEVELOPMENT

In order to determine whether or not existing aircraft hoist hardware might be suitable for the snubbing concept, a rough-cut preliminary design was developed first by Boeing Vertol to define system requirements. Highlights of this preliminary analysis work are summarized in Table 3.4; and the final hoist design resulting therefrom is sketched in Figure 4.11.

The principal results of the study found that about 12 horsepower were required to raise the load to a snubbed position, in the one minute requirement stipulated in initial criteria. This level of power can be supplied by the CH-47D electrical system, with an excess capability available for later additions of terrain flying NAV/COM gear in the future.

To meet the ultimate load carrying requirements for the hoisting system of 60,000 lb (resulting from 2g maneuvers,

REF: 114-FY-704-1, CH-47C HELICOPTER VIBRATION COMPLIANCE REPORT.
 NOTE: MANEUVERS WILL REDUCE STEADY GEAR DISPLACEMENTS OF .16 INCH/g.

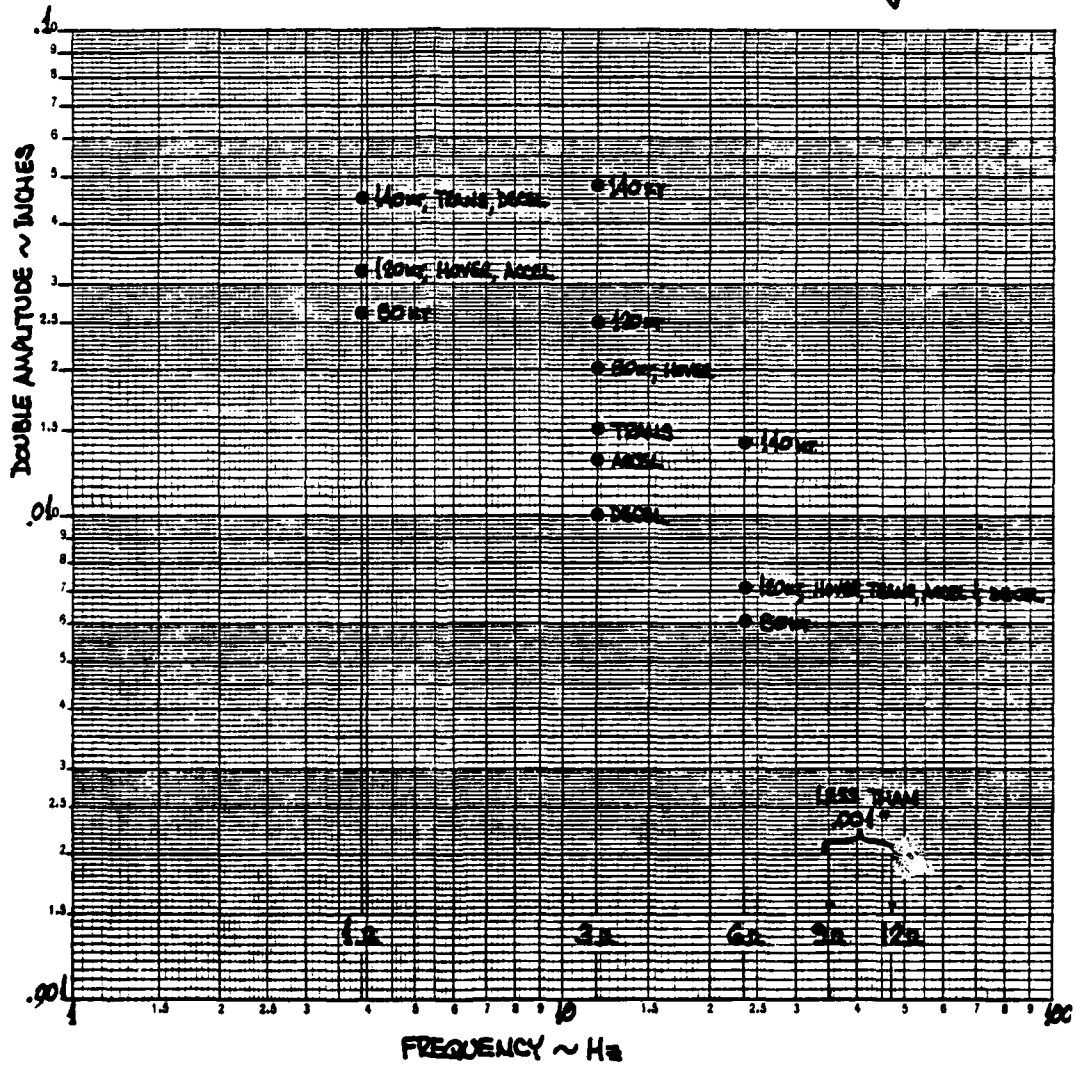

Figure 3.9 CH-47C Vibratory Gear Motions With Snubbed External Loads

LOAD SNUBBING HOIST - PRELIMINARY DESIGN

1. DESIGN CRITERIA

- EACH ATTACHMENT TO HAVE ULTIMATE LOAD CAPABILITY OF 60,000 LBS
- TOTAL PRE-LOAD ON LANDING GEAR OF 5,000 LBS (1,250 LBS EACH NOMINAL)
- HOISTING TIME NOT TO EXCEED ONE MINUTE

2. HP REQUIREMENTS

BASED ON 12 FT. OF CABLE AND HOISTING TIME OF ONE MINUTE:

$$HP_{(OUT)} = \frac{25,000 \text{ LB PAYLOAD} \times 12 \text{ FT}}{33,000} = 9.1 \text{ HP}$$

ASSUME 85% EFFICIENCY AND 90% POWER FACTOR

$$HP_{(IN)} = \frac{9.1}{.85 \times .9} = 11.9 \text{ HP AC}$$

3. CABLE SELECTION

60,000 LB ULTIMATE LOAD

MIL-C-5424 CABLE REQUIRED TO BE .875" DIA

HLH TYPE CABLE REQUIRED TO BE .625" DIA

ALTERNATIVES TO BE CONSIDERED:

- DESIGN HLH TYPE CABLE .625" DIA 61,000 LB UTS
 - USE EXISTING HLH CABLE DESIGN .700" DIA 75,000 *
 - USE MIL-X-5424 CABLE (LOW FLEXIBILITY) .875" DIA 66,000
 - USE MIL-C-5424 CABLE .625" DIA 35,000 **
- * THIS ALTERNATIVE WOULD REDUCE PAYLOAD BECAUSE OF EXCESS CAPABILITY - COULD BE CONSIDERED FOR PROTOTYPE UNITS
- ** NO 3/4 INCH CABLE AVAILABLE

4. EQUIPMENT SURVEY

VENDORS CONTACTED:

- ALL AMERICAN ENGINEERING CORPORATION
- WESTERN GEAR CORPORATION
- BREEZE CORPORATION
- HOOVER ELECTRIC COMPANY

NO EXISTING EQUIPMENT AVAILABLE WITH THE REQUIRED CAPACITY, OR SIZE ENVELOPE

5. PRELIMINARY HOIST DESIGN

THREE CONFIGURATIONS OF HOIST WERE CONSIDERED:

- CENTER MOUNTED, DUAL DRUM HOIST WITH 5/8 DIA. CABLE
- CENTER MOUNTED, DUAL DRUM HOIST WITH 7/8 DIA. CABLE
- TANDEM HOISTS, MOUNTED AT HOOK LOCATIONS WITH 5/8 DIA. CABLE

WEIGHT TRENDS WERE PREDICTED USING HLH HOIST DATA, AND WEIGHT TREND INFORMATION FROM USSAMRDL TECHNICAL REPORT 74-97A. ALL DESIGNS USE D/d RATIO OF 25. (DRUM/CABLE DIAMETER)

CONFIGURATION	CABLE DIA.	PREDICTED HOIST WEIGHT - LB	ESTIMATE OF SHEAVE INST. WT.	TOTAL WEIGHT
SINGLE HOIST, DUAL DRUM	.625	500	70	570
SINGLE HOIST, DUAL DRUM	.875	761	85	846
TANDEM HOISTS	.625	250 EACH	0	500

6. CONFIGURATION SELECTION

THE TANDEM HOIST CONFIGURATION WAS SELECTED BECAUSE OF:

- LOWER HOIST SYSTEM WEIGHT
- INCREASED FATIGUE LIFE DUE TO ELIMINATING SHEAVES (PULLEYS)
- NO FLEET ANGLE PROBLEMS
- SIMPLIFIED STRUCTURE - NO COMPRESSIVE LOADS IN ADAPTER
- PROVIDES DIFFERENTIAL HOISTING CAPABILITY

Table 3.4 Load Snubbing Hoist - Preliminary Considerations & Design

with a 1.5 ultimate load factor included) 5/8" cable is required, and needs to be flexible enough to coil over reasonable sized drum diameters without creating undesirable fatigue life constraints. Super-flexible cable of the type developed for the HLH helicopter, and described in Reference 5, meets this requirement.

For the demonstration prototype snub load units, actual HLH cable (0.70 inches in diameter) could be used, and the hoist drums (discussed in Section 4) have been sized to utilize this diameter cable. Application of the HLH cable would, of course, incur a weight penalty - but this would probably not be excessive for any demonstrator ECHS fabricated to prove that load snubbing is a workable concept.

In addition to sizing power and cable parameters for a load snubbing hoist, it was also determined (as shown at the bottom of Table 3.4) that tandem hoist systems were considerably lighter than comparable single hoist devices employing pulley sheaves at either end of the adapter to route cables up to the cargo hooks. The principle advantages of the dual hoist approach over the single system are pointed out in Item 6, at the bottom of the table.

Industry Hardware Survey

Using the preliminary design first discussed, a survey of available aircraft hardware revealed that no hoists were currently capable of meeting the needs of the snubbing system. One hydraulic powered hoist, the Breeze model BL-6700, could be reeved with pulleys to carry a reduced load factor snubbing system, but was otherwise totally unsatisfactory for application with the Vertol snubbing concept for reasons given later in Section 4.4.

4.0 PHASE II/III - PRELIMINARY DESIGN, INCLUDING LAYOUTS/CIDS

The concept established in the Phase I task has been developed into a preliminary design, and is described in this section. Major areas of consideration during these two phases of the program include: System Operation, Structural Configuration, Load Analysis, Hoist Design, Isolator Configuration, Load Acquisition and Release, Electrical Requirements, Airframe Mods, ECHS Dynamics, Safety and Emergency Operation, and Costs and Weights.

Figure 4.1 illustrates the general arrangement of the ECHS before the Phase IV wind tunnel program was conducted. Phase IV results showed that improved performance could be obtained by modifying the shape of the ECHS structure. These changes have been incorporated in the preliminary design, and the latest general arrangement of the ECHS is shown in Figure 4.2.

The end result of this preliminary design effort is a Critical Item Development Specification (CIDS), included as Appendix A of this report.

4.1 SYSTEM DESCRIPTION & OPERATION

Figure 1.2 illustrates the External Cargo Handling System (ECHS) acquiring an 8 x 8 x 20 foot container. Also shown is the ECHS in its snubbed mode, interfaced between the helicopter and the container during forward flight.

The ECHS consists of the following elements:

1. A basic structure that provides the support for the four twistlock elements to interface with a standard ISO 20 ft. container; the six guide arms to locate and assist in inserting the twistlocks into the container; and two hoists and their associated system to permit the ECHS to snub against the aircraft. The basic structure includes the extensions and pads required to locate and interface the adapter with the aircraft landing gear.
2. A twistlock system that will engage with the ISO container. The twistlocks are actuated by a single electrical actuator, with mechanical interconnection. A manual lever will provide an override capability for backup ground use, or when electrical power is not available.
3. Guide assemblies are located to provide one guide arm at each end of the container and two guide arms on each side. The guide arms are readily removable for replacement, or to allow loads to be positioned in restricted areas.

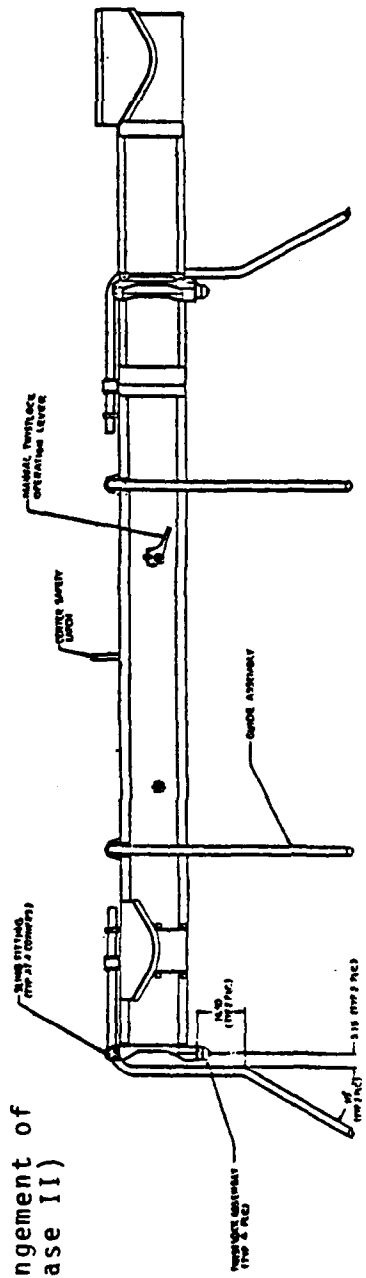
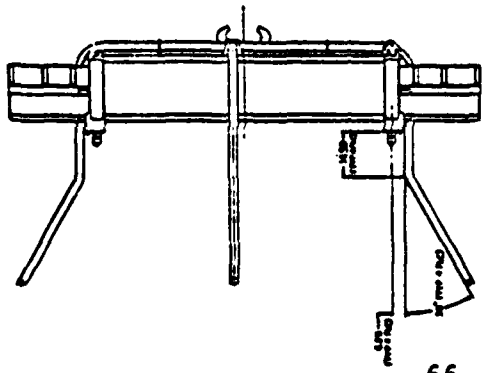
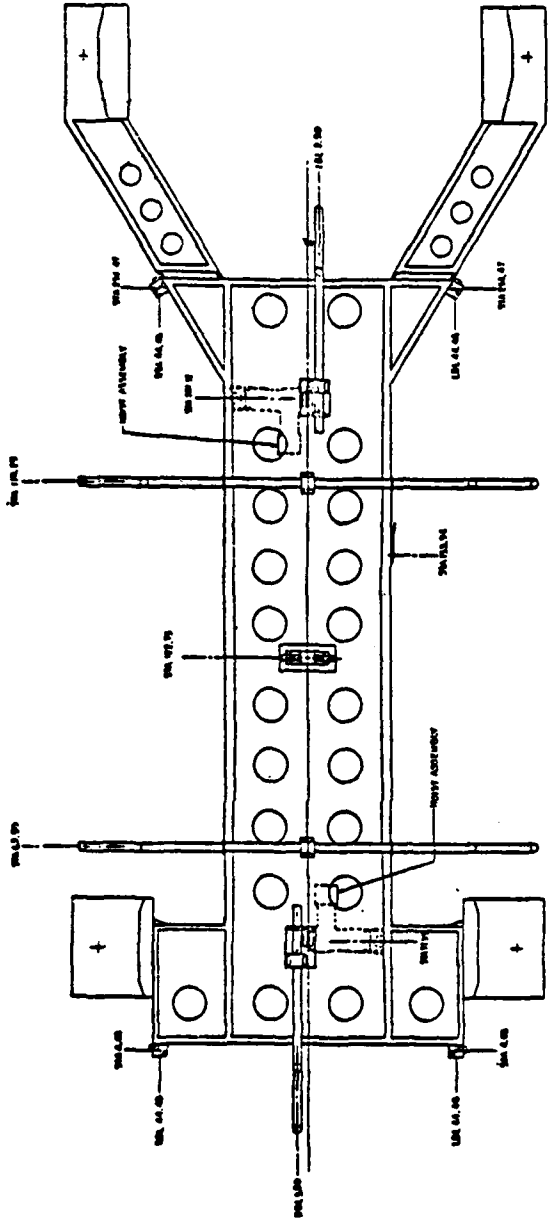

Figure 4.1 General Arrangement of Original (Phase II) Adapter

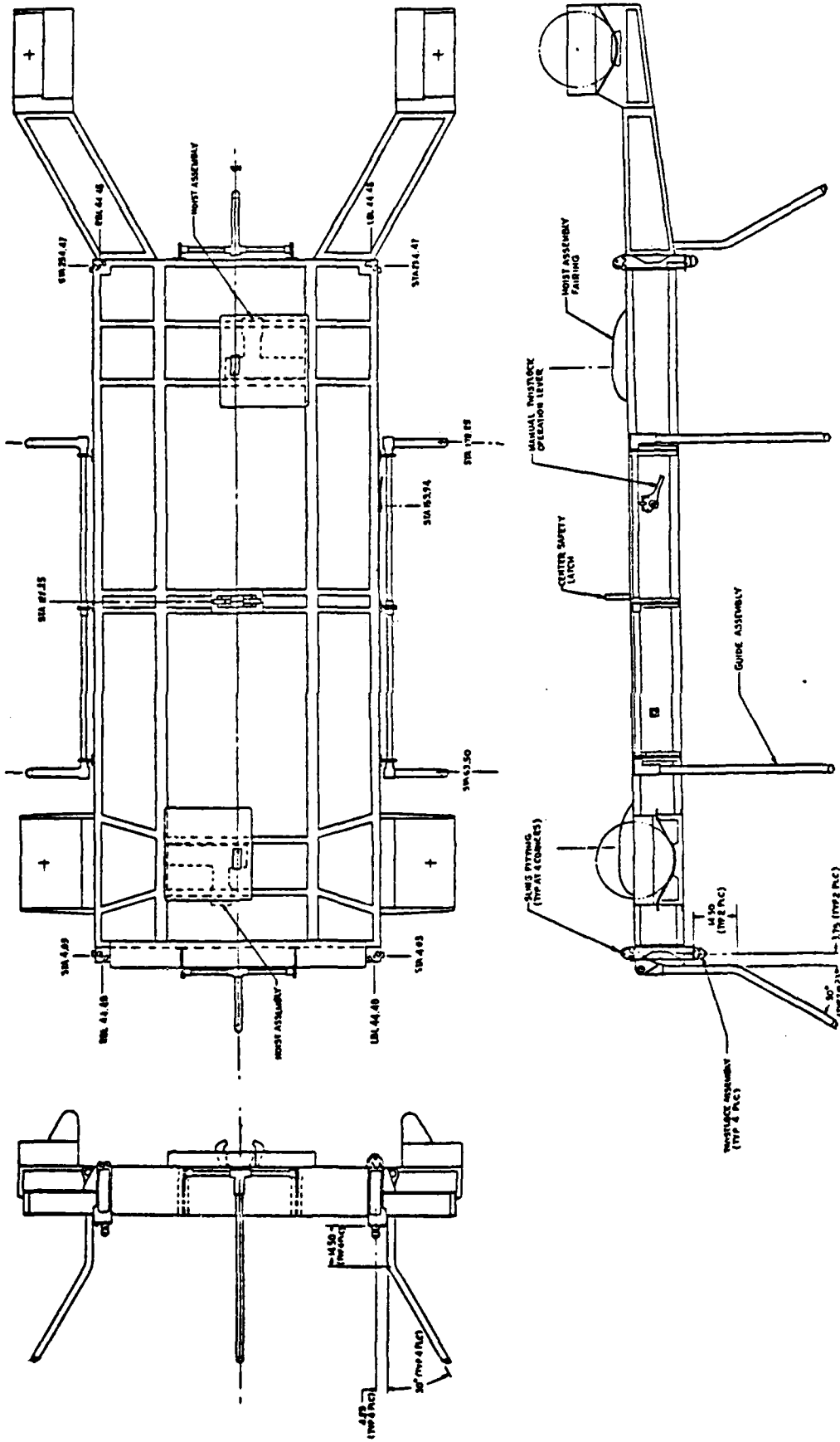

Figure 4.2 General Arrangement of ECHS Final Adapter.

4. Two hoists shall be arranged at locations to suit the tandem hook spacing on the CH-47D. The hoists are to be powered from the aircraft's electrical system by means of an umbilical cord. The hoists are mounted with dynamic isolators to prevent amplification of the airframe vibration degrading the aircrew environment.

The ECHS system will operate as follows:

The ECHS is positioned in a clear area, supported on the six guide arms. The hoist cables are fully out. (This would be the normal final configuration on completing an operation. If the cables have been rewound on the drums for storage, a ground power unit may be used to provide power to deploy the cables prior to use.) The ECHS may also be positioned alongside the CH-47D helicopter and the umbilical cable connected from the helicopter to the ECHS junction box, providing power to deploy the cables.

The CH-47D helicopter will have a hoist motor speed control unit and ECHS control panel on board. The control unit will be connected to the aircraft AC bus. The control panel will be connected to the motor speed control unit and to the cabin DC power outlet, and to the remote pilot override control installed in the cockpit. A pre-coiled umbilical cable is attached to the motor speed control unit via breakaway type quick disconnects. The umbilical cable is located adjacent to the open hatch at the center hook. The center hook would be down, ready for use.

The helicopter will hover over the ECHS at approximately 12 feet above the ground, initially aligned parallel to the adapter longitudinal axis, with the aft gear snubbing arms extended rearward. The umbilical cable is passed through the hatch to a ground crewman stationed on the ECHS, and is connected to a junction box on the ECHS structure. The ground crewman will then take the eye terminal of the forward hoist cable and attach it to the forward hook, followed by attachment of the aft hoist cable to the aft hook. The ground crewman will descend from the ECHS and clear the area. Alternatively, the two hoist cables may be connected to the hooks while the aircraft is still on the ground (with the adapter beside it) prior to takeoff, to prevent the ground crewman from having to stand close beneath the helicopter during hookup.

The helicopter will then lift the ECHS clear of the ground and energize the "hoist-up" control on the control panel, until the "safe to lift" indicator is lit on the control panel. The ECHS will now be suspended approximately 10 feet below the helicopter in a level attitude. The helicopter is then flown to the cargo area and positioned over the container or Gondola to be transported. The helicopter will slowly

descend until the ECHS guide arms are located just above the load. Continued descent will center the twistlocks on the receptacles on the container, and the weight of the ECHS is supported by the container.

At this time, the corner interlock down indicator will light on the control panel and the twistlock "lock" position can be selected. When the twistlocks are all locked, the "locked" indicator will light on the panel. The helicopter will now ascend, lifting the ECHS and the load clear of the ground. The operator now selects "hoist up" on the panel. The hoist select switch must be in "both" during normal operations. The forward hoist will begin to reel in its cable followed by the aft hoist, thus pulling the ECHS toward the helicopter. As the ECHS approaches the helicopter, the attitude of the ECHS is gradually changed to match the nose-up attitude of the aircraft. When the ECHS contacts the landing gear, limit switches will de-energize the hoists and the hoist brake will engage. The limit switches will be adjusted to provide the correct amount of pre-load on the landing gear. The "load snubbed" indicator will now be lit and the hoist control switch can be positioned "off".

The center hook attachment latch will now engage the center hook by means of the latch actuator; sequenced to operate after the hoists are "off". This is a fail-safe attachment and is only loaded if the forward or aft attachment fails. The load is now snubbed to the helicopter and can be flown to its destination.

At the destination, the helicopter will hover approximately 40 feet above the ground and the operator will select "down" on the hoist control. The first action on selecting "down" is for the center hook latch actuator to open the latch. The ECHS will then lower itself from the helicopter until the hoist mounted limit switches prevent further cable payout. The ECHS, with the load, will now be approximately 10 feet below the helicopter in a level attitude. The helicopter now descends to position the container as required on the surface. When the weight of the load is on the ground, the "down" indicator will light on the panel, and the twistlock "unlock" switch position may be selected. When the "unlocked" indicator is lit, the helicopter can ascend. The helicopter then returns for further loads with the ECHS suspended, or while in hover, the ECHS may be raised to snub with the landing gear for greater speed capability.

To refuel the helicopter without detaching the ECHS, the unloaded ECHS may be lowered beyond the normal down position by selecting "override down" on the panel. This will permit the ECHS to be suspended approximately 20 feet below the helicopter, allowing the ECHS to be lowered to the ground and the

helicopter to land alongside. An interlock feature will prevent the ECHS from lifting a load when the cables are in the extended configuration.

On completion of a mission requiring the ECHS, the system would be removed from the aircraft by disconnecting the umbilical cable at the ECHS junction box and then opening the hooks to release the cables. The load and the ECHS may be jettisoned in flight by operating the standard aircraft hook emergency release switch in the cockpit. All three hooks will open and the ECHS complete with load will fall away from the aircraft, disconnecting the breakaway fittings of the umbilical cable.

4.2 STRUCTURAL ARRANGEMENT

This preliminary design of the ECHS consists of a conventional aluminum alloy sheet and extrusion structure, arranged to mount twistlocks, guides, and hoists with a strength level consistent with the CH-47D structure.

The initial Phase II structural design is shown in Figure 4.3. The basic structure has a rectangular box section, approximately 21 x 42 inches cross section, by 230 inches long. The structure has angle section longerons at each corner, extending the full length of the structure. Aluminum alloy sheet skins are assembled to the inside face of the angles to allow all frames and stiffeners to be mounted flush on the inside surface. Sheet metal frames are located where necessary to support equipment or provide load paths. These frames have extruded aluminum caps or integral flange as necessary for the loads to be carried. The upper and lower skins have large lightening holes to reduce weight and provide access.

The basic structure has lateral extensions at the forward end. These extensions mount the two forward twistlock housings and the forward landing gear snubbing pads. The frame between the twistlock fittings is continuous, closing off the rectangular box structure. The aft end of the box has extensions that extend laterally and rearward, to mount the two aft twistlock housings and the aft landing gear snubbing pads. The aft extensions are constructed in a similar manner to the basic box. The design has bolted joints for the four landing gear snubbing arms, allowing these extensions to be removed for storage and transit; also permitting the ECHS to be used as a suspended acquisition device. Extension of each twistlock housing above the upper surface of the ECHS provides lifting points for using conventional slings to suspend the device when not used in the snubbed mode. When the extensions are removed all basic structure is within the 8 foot x 20 foot plan area of the container.

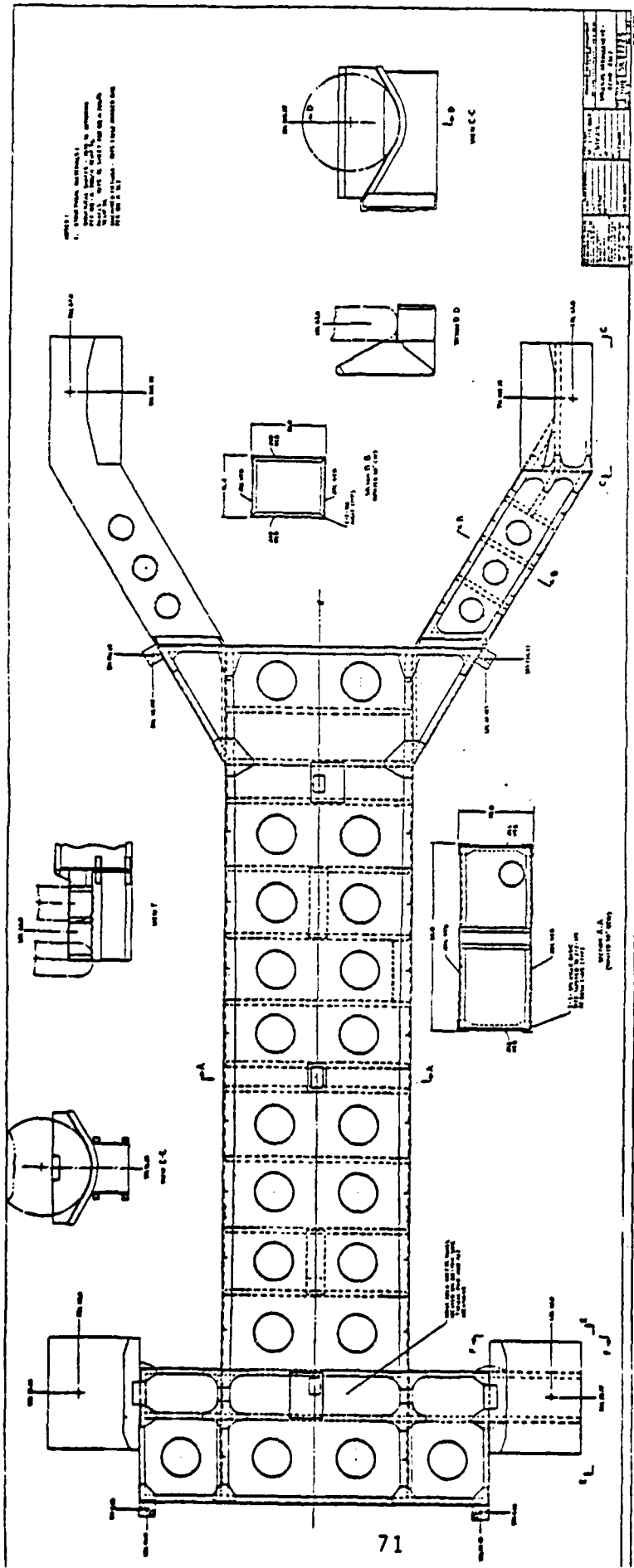

Figure 4.3 Initial Phase II Structural Design

The material used is generally 7075-T6 or T73 sheet, extrusions and bar stock. The vertical webs of the main box are .063 thick, and the horizontal webs .036 thick. The corner longerons start as 3 x 3 x 3/8 angles and taper to 2 x 2 angles at either end. The main box design is dictated by the center fail-safe hook attachment.

During the Phase IV wind tunnel program, the ECHS model was modified to reduce drag and improve stability. The modifications consisted of the following:

1. An increase of adapter incidence angle with respect to the fuselage. This change, a 3° delta, was accomplished by lowering the forward wheel support pad and raising the aft wheel pads, to a point tangent with the adapter upper surface.
2. An increase in width of basic structural box to line up with sides of the MILVAN load.
3. Streamlining the upper leading edge of the adapter structure.

On completion of the wind tunnel test, the structural arrangement was revised to include these changes. Figure 4.4 shows the revised structural arrangement. This revised structure provides for two longitudinal box beams, each approximately 22 inches wide by 16 inches deep, and separated by 52 inches laterally. Lateral frames join the two box sections at the twistlock locations, hoist locations, and center hook attachment. The vertical and horizontal webs of each box are approximately .032 aluminum alloy 7075-T6, with the longerons being 7075 extrusions (approximately 2 x 2 x 1/4 angle sections).

Figures 4.5 and 4.6 show details of the wheel pad structure. The hoist support structure remains similar to the initial structural concept, and is shown on Figure 4.7. Arrangement of the center hook attachment is shown on Figure 4.8.

The ECHS fail-safe center latch is an over center design, operated by an electrical linear actuator sequenced to close the latch as the final action when the ECHS is snubbed; and opening the latch as the initial action on lowering the adapter.

The sheet and stringer structural approach described above is applicable to an initial developmental quantity of (prototype) ECHS's. Significant weight reduction in the structure could be achieved by utilizing the superior properties of advanced composite materials such as Kevlar and Graphite. Experience with the re-design of similar conventional structural

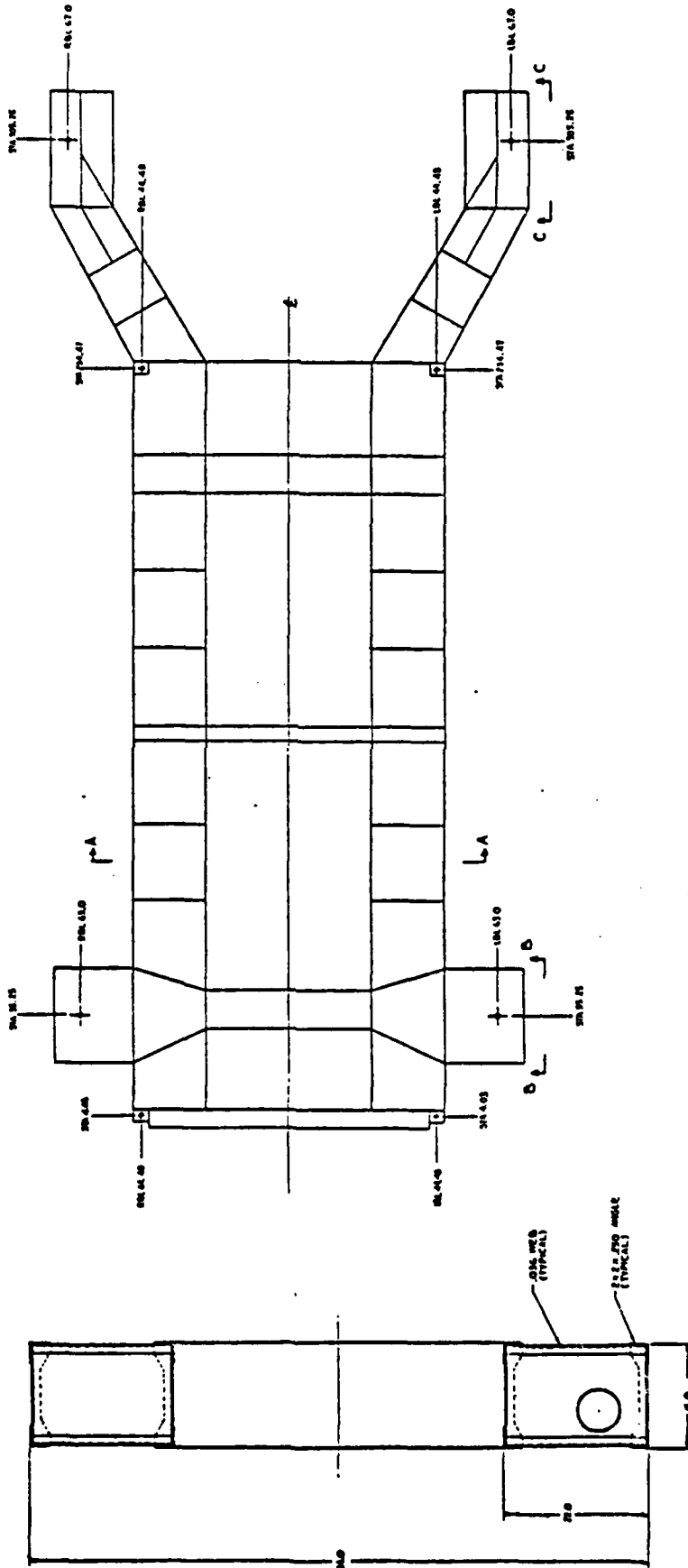

Figure 4.4 Final ECHS Structural Design

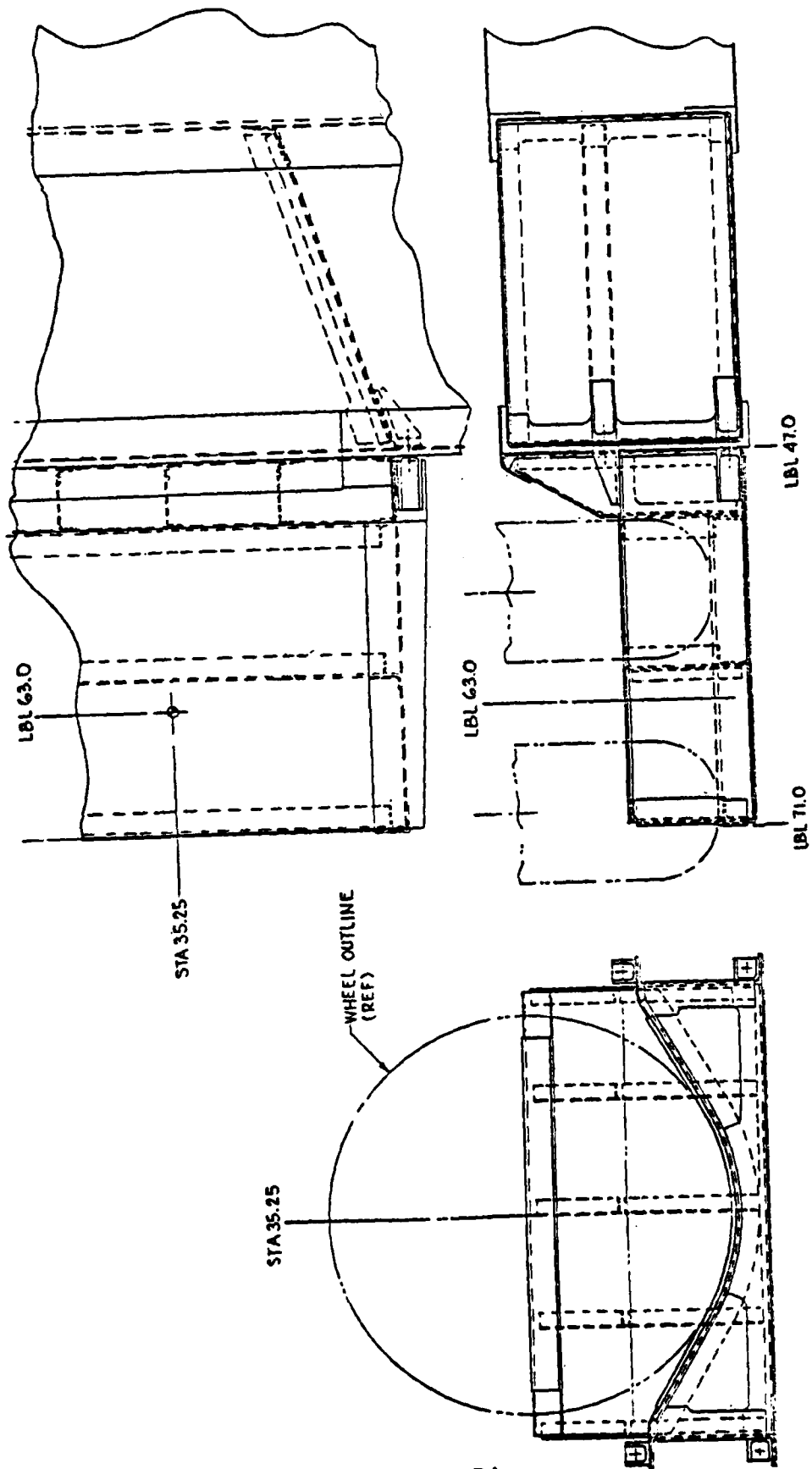

Figure 4.5 Wheel Pad Structure - Detail

VIEW B-B
FORWARD LANDING GEAR INTERFACE

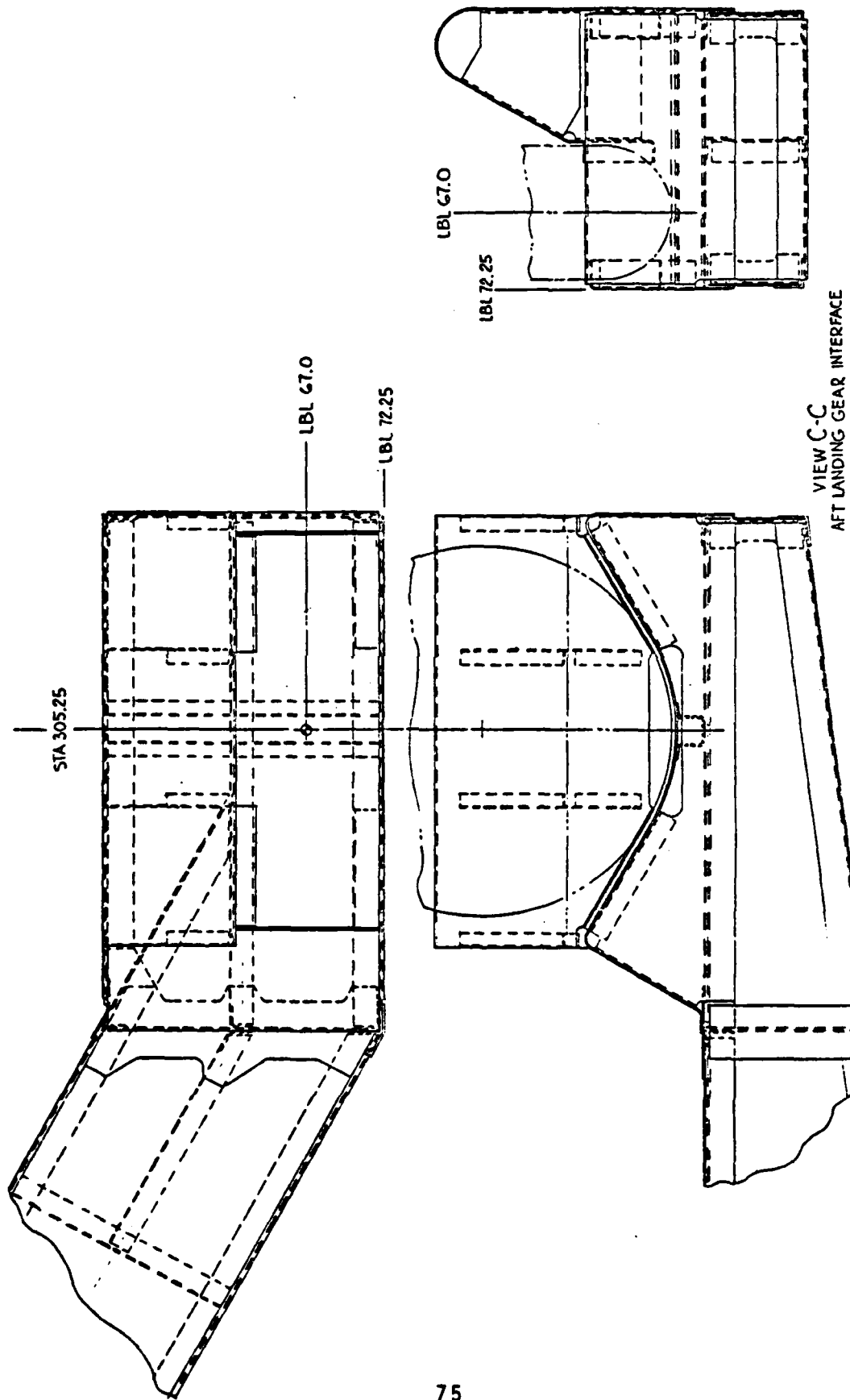
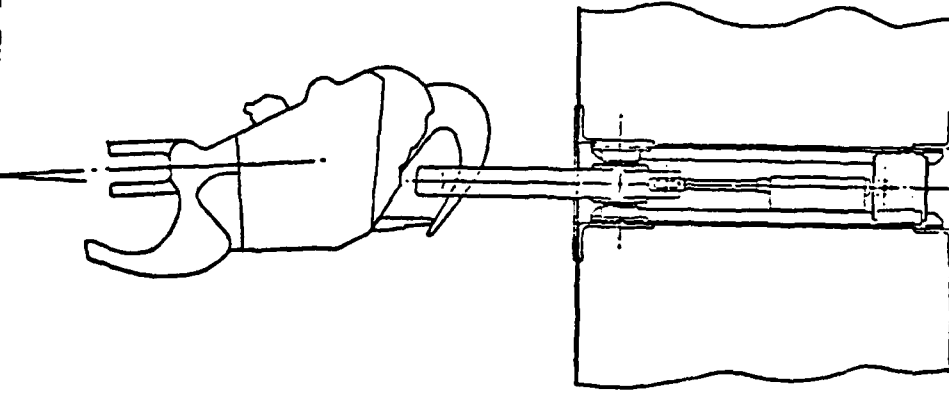

Figure 4.6 Wheel Pad Structure - Detail

Sta. 331.0 (ACFT)
WL 36.0 (ACFT)



ACFT and Device

Center Cargo Hook (ACFT)

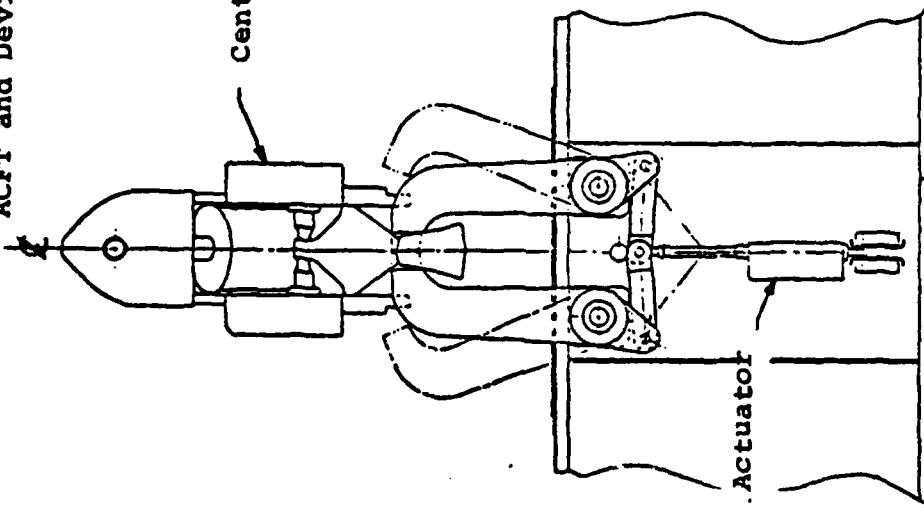

Electro-
mechanical Actuator

Figure 4.8 Center Hook Redundant Safety Attachment

arrangements to include composite structural elements has resulted in an approximate 25% weight saving. The projected weights for a fully developed "production" type ECHS reflect such a reduction.

4.3 LOAD & STRESS ANALYSIS

On completion of the Phase I concept selection, a preliminary load analysis was conducted in order to generate a viable structural design.

The analysis was based on the following assumptions and considerations:

- 1) Aircraft Gross Wt. = 25000 lb, CG Sta 331, WL 40 BL 0
Cargo Wt. 25000 lb, 20' x 8' x 8' Box with CG at
Geometric Center (A/C Sta. 331, WL -136, BL 0)
- 2) Geometry as in Figure 4.9
- 3) Variation of cargo CG considered
Longitudinal ~ giving 60/40; 50/50; 40/60 Cable Load
Lateral ~ ± 10 "
- 4) Flight maneuvers considered are as shown in Table 4.1
- 5) Air pressure loading considered

	C_L	C_D	C_p	V (KN)
(a)	+ .075 (UP)	.35 (AFT)	-.03 (NOSE DN)	135
(b)	-.075 (DN)	.35 (AFT)	+.03 (NOSE UP)	135
	(160 FT ²)	(160 FT ²)	(160 FT ² x 20 FT)	

- 6) Snubbed gear loading (preload) - 1250 lb/gear
- 7) Mass moments of inertia (slugs-ft²):

	I_{XX} (ROLL)	I_{YY} (PITCH)	I_{ZZ} (YAW)
A/C	22800	213000	198500
CARGO	8282	30021	30021
A/C + CARGO	114690	326530	228520

The results of the load analysis are shown in Table 4.2.

The ultimate loads developed at the hoist cables do not exceed the 60,000 lb maximum load design criteria for the forward and aft hooks, and hook support structure. The loads generated at the landing gear assume a rigid system. As the oleo must compress to generate these reactions, the actual result is a reduction in tension of the appropriate hoist cable and a lower reaction at the landing gear. Using this

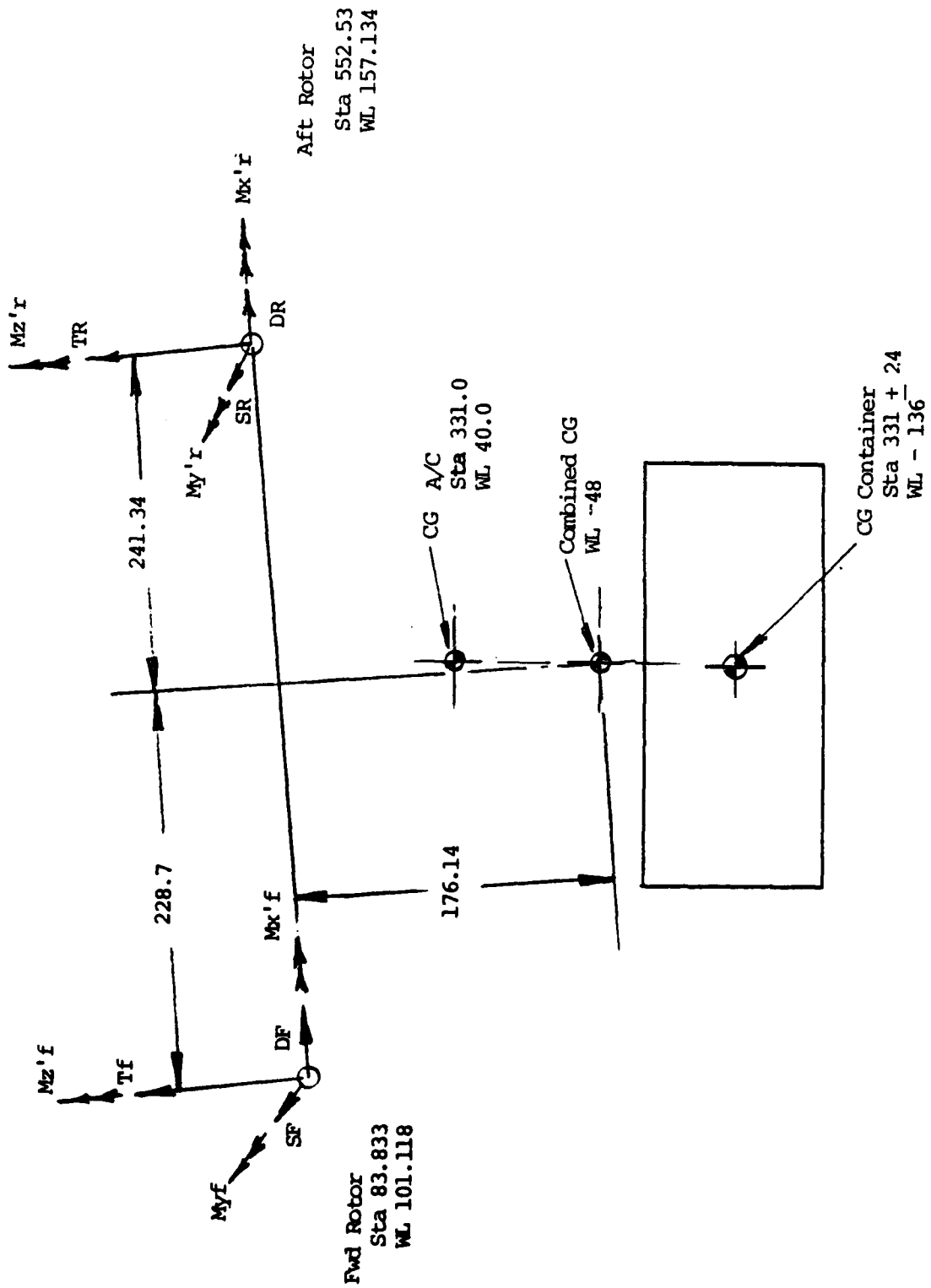
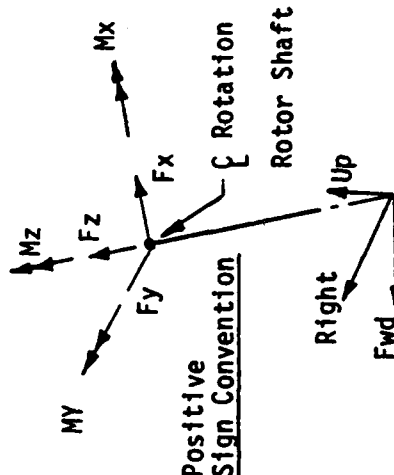

Figure 4.9 Geometry of Snubbed Load

DESIGN CONDITIONS

CONDITION DESCRIPTION	COND. NO.	ROTOR	ROTOR TORQUE M_z % TOTAL	ROTOR THRUST F_z F_z R_z	LIMIT LOAD FACTOR AT C.G.	ULT. FACTOR	ROTOR LOADS IN % OF THRUST DRAG SIDE		THRUST POSITION TO DEVELOP HUB MOMENTS M_x M_y
							F_x	F_y	
SYMMETRICAL DIVE AND PULLOUT ZERO PITCHING	1	FWD	-50	nwb/c	2.0	1.5	0	0	CENTERLINE OF ROTATION
		AFT	50	nwa/c			0	0	
SYMMETRICAL DIVE AND PULLOUT NOSE UP PITCH	2	FWD	-50	$1.2nw^b/c$	1.5	1.5	25	0	FORWARD HORIZONTAL
		AFT	50	$nw-F_zF$			25	0	
SYMMETRICAL DIVE AND PULLOUT NOSE DOWN PITCH	3	FWD	-50	$nw-F_zR$	1.5	1.5	-14	0	AFT HORIZONTAL PIN
		AFT	50	$1.2nwa/c$			-14	0	
RECOVERY FROM ROLLING PULLOUT LEFT OR RIGHT	4	FWD	-50	$nw-F_zR$	1.2	1.5	-14	± 14	$\pm 45^\circ$ FROM AFT HORIZONTAL PIN
		AFT	50	$1.2nwa/c$			-14	± 14	
ONE LIFT POINT FAILED SYMMETRICAL DIVE AND PULLOUT-ZERO PITCH	5	FWD	-50	nwb/c	2.0	1.0	0	0	CENTERLINE OF ROTATION
		AFT	50	nwa/c			0	0	

LIFTING POINTS INTACT
80



n = NORMAL LIMIT LOAD FACTOR AT C.G.

w = AIRCRAFT GROSS WT. - 50,000 LB

a = DISTANCE FWD ROTOR TO C.G.

b = DISTANCE AFT ROTOR TO C.G.

c = DISTANCE FWD ROTOR TO AFT ROTOR

DISTANCE CENTERLINE ROTATION TO HORIZONTAL PIN = 8.15"

LIMIT FACTOR ON ROTOR TORQUE = 1.4, ALL CONDITIONS

Table 4.1 Flight Maneuver Design Conditions

CH-47D SNUBBED EXTERNAL CARGO TABLE II

MAXIMUM REACTIONS

REACTION	MAXIMUM ULTIMATE LOAD (LB.)							
	MANEUVER		GEAR PRE-LOAD	C.G. TRAVEL		AIR LOAD 135 KT	TOTAL (ULTIMATE)	
	COND	LOAD		F & A	LAT.			
R1 FWD. L.H. GEAR	V	4	4331	1875		3672	9878	
R2 FWD. R.H. GEAR	V	4	4331	1875		3672	9878	
R3 FWD. GEAR	LAT	4	±3764				±3764	
R4 AFT. L.H. GEAR	V	4	3515	1875		2981	8371	
R5 AFT R.H. GEAR	V	4	3515	1875		2981	8371	
R6 AFT GEAR	LAT	4	±1276				±1276	
R7 FWD. CABLE	V	1	35484	1360	12329		3723	52896
R8 AFT CABLE	V	1	39516	6140	10172			55828
R9 DRAG PER GEAR		3	1862					1862
R10 CENTER CABLE	V	5	50000		13954			63954

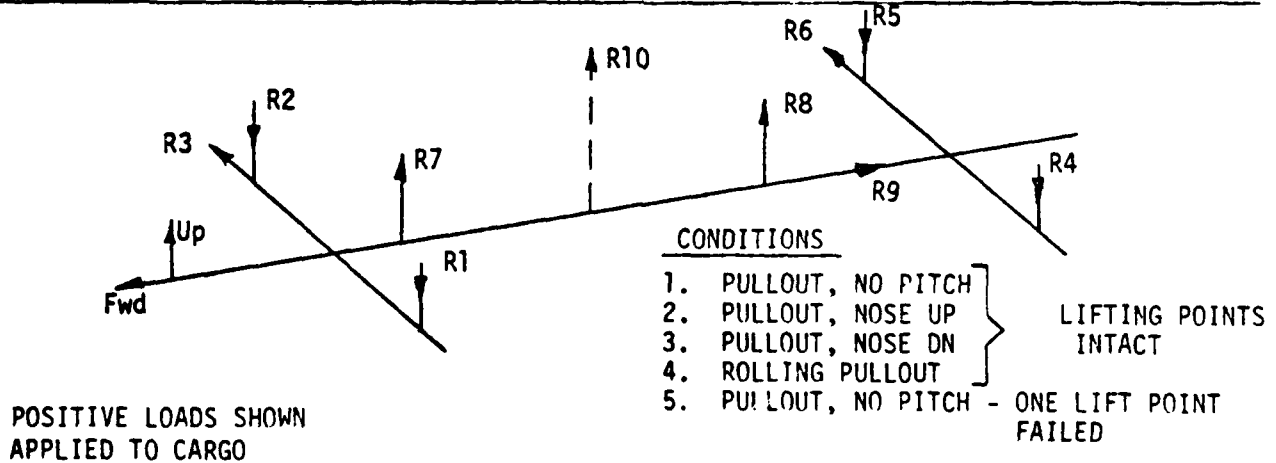

Table 4.2 Results of Load Analysis

rigid body assumption to design the landing gear pad extensions introduces a degree of conservatism.

A more rigorous analysis in the future, when the detail design is completed, would probably result in a lower weight structure. The results of the Phase IV wind tunnel tests, to determine airloads on the MILVAN and adapter, should be included in this analysis, to reflect loads accruing from high angle of attack and sideslip conditions existing for critical design conditions.

The design case for the basic twin parallel box structure is that resulting from failure of either a forward or aft attachment point. The load results in a maximum bending moment at the center hook location of 3.5 million inch-lbs.

Table 4.3 presents the results of a preliminary stress analysis of the aft landing gear extension, and of the twin box beam basic structure of the adapter. Sizing of longeron and web material thickness is annotated.

4.4 HOIST DESIGN

The hoisting system for the ECHS is the key element to a successful snubbing arrangement. During initial concept formulation, consideration was given to installing hoists in the CH-47, avoiding the need to transfer power from the aircraft to the ECHS. This approach was abandoned due to the extensive structural changes to the aircraft that would have been required, violating the principal ground rule of minimum aircraft modification.

A design was formulated for a single hoist installed on the ECHS, with dual cables operating over sheaves (pulleys) to align the cables with the CH-47D tandem hook spacing. A weight estimate made during Phase I of the program established that two individual hoists would be lighter than a single, central hoist operating with two sheaves. The use of two individual hoists had additional advantages - cable fatigue life is improved by eliminating sheaves; fleet angle problems are eliminated; and structural simplification is possible. The ability to provide differential hoisting is also an advantage of the two hoist arrangement.

Following this Phase I work, consideration was restricted to the use of two identical hoists only, to snub the adapter.

An in-house hoist design provided the basis for a weight estimate and determined a possible envelope. This information, together with the following criteria, was circulated to suppliers of aircraft hoists for review of existing designs that would fulfill, or be modified to fulfill, these requirements.

STRESS ANALYSIS

PRELIMINARY SECTION REQUIREMENTS

BASIC BOX BEAM

DESIGN CASE: FWD HOOK FAILED
CG 10% FWD & 10% LATERAL
DESIGN LOAD: 25,000 LB
LIMIT LOAD: 50,000 LB
ULTIMATE LOAD: 50,000 LB
RESULTS IN: MAX VERT SHEAR 15,000 LB/WEB
MAX BEND MOMENT 3,516,600 IN-LB/TOTAL
BASIC SECTION: 22" WIDE X 16" DEEP - TWO BOX SECTIONS
(52" APART)
VERTICAL WEBS - .032 7075-T6
VERTICAL STIFFENERS - .75 X .75 X .09 ANGLES
AT APPROX. 11"
SPACING
CORNER MEMBERS - 2 X 2 X .25 ANGLES
HORIZONTAL WEBS - .032 7075-T6

AFT LANDING GEAR ARM

DESIGN CASE: ROLLING PULLOUT (COND 4)
RESULTS IN: VERT LOAD 8371 LB ULT
LAT LOAD (ASSUME TO ACT ON ONE GEAR)
1,276 LB ULT
BASIC SECTION: 16" WIDE X 16" DEEP
VERTICAL WEBS - .036 7075-T6
VERTICAL STIFFENERS - .75 X .75 X .09
ANGLES AT APPROX.
15" SPACING
CORNER MEMBERS - 1.5 X 1.5 X .125
7075-T6 ANGLES
HORIZONTAL WEBS - .032 (HANDLING)

TABLE 4.3 STRESS ANALYSIS

HOIST CRITERIA

- Each hoist shall be capable of operating at the maximum design load resulting from the adverse CG condition. With a 160 inch hoist separation and a 24 inch CG offset, the 25,000 pound design load will result in a maximum hoist design load of 16,250 pounds.
- The hoist shall operate at a minimum speed of 10 feet per minute at 80% of design load (13,000 pounds).
- The hoist shall be capable of operating at an inertia factor of 1.2 times the maximum design load. $1.2 \times 16,250 = 19,500$ pounds.
- The hoist shall be designed to operate at the 19,500 pound load within a 15° cone angle from the vertical.
- The hoist overrun under any load condition shall not exceed 0.5 inch cable travel.
- The hoist speed may be lower than 10 feet/minute at loads above 13,000 pounds.
- The hoist shall be capable of holding a static load of 40,000 pounds without permanent deformation (limit load).
- The hoist shall be capable of holding a 60,000 pound load without failure. The hoist may experience permanent set at this load (ultimate load).
- The hoist drum shall be suitable for a cable with a 60,000 lb min. breaking strength. The drum mean diameter shall not be less than 18 inches. Consideration shall be given to a cable construction as developed for the HLH helicopter and described in report USAAMRDL-TR-74-97A. (Reference 5).
- The cable length shall result in a usable extension of 12 feet under full load, and a usable extension of 22 feet when unloaded (ECHS weight only). In the latter case there shall be a minimum of 1.5 dead wraps on the drum.

- The free end of the cable shall be formed into a loop using a MacWhyte crescent thimble, No. C-4 or equivalent. This thimble has a 1.5 inside radius loop. The free end shall be swaged through an eye splice sleeve as shown on Figure 4.10.
- The hoist design duty cycle shall be 4 minutes on; 20 minutes off. The 4 minutes on shall consist of raising the maximum design load (16,250 pounds) 10 feet, lowering the load 10 feet, raising the load 10 feet and lowering the load 10 feet.
- The hoist shall be powered by an electric motor, suitable for 115/208 VAC, 400 cycles, 3 Ph.
- Hoist efficiency shall be such that at 80% of design load and at design speed, the hoist will not require more than 6 HP (4,480 watts).
- Adjustable limit switches shall ensure that a minimum of 3 1/2 wraps of cable remain on the drum when operating under load, and a minimum of 1 1/2 wraps of cable remain when operated without a load.
- The hoist attachment to the structure shall provide for incorporation of a load isolator to the criteria of Section 4.5. Figure 4.16 illustrates a suitable schematic arrangement of hoist and isolator.

The basis for this criteria is the ability of the CH-47D electrical system to supply power for the ECHS.

Figure 4.11 shows the Boeing Vertol preliminary hoist design. The industry survey did not uncover any existing designs that would meet the criteria, or come sufficiently close to be modified for ECHS use. An existing Breeze design of Capstan Hoist, part number BL-6700 (Figure 4.12) was considered for modification for prototype use. This hoist is basically a hydraulic powered unit of 6000 lb capacity. Use of this design would involve reeving the cable (with pulleys) to increase the capacity to 12000 lb. Disadvantages of this arrangement are:

- 1) The crewman would need to lift a combined sheave and ring to attach it to each aircraft hook. The combined weight, with the supported cable, would be on the order of 40 lbs.

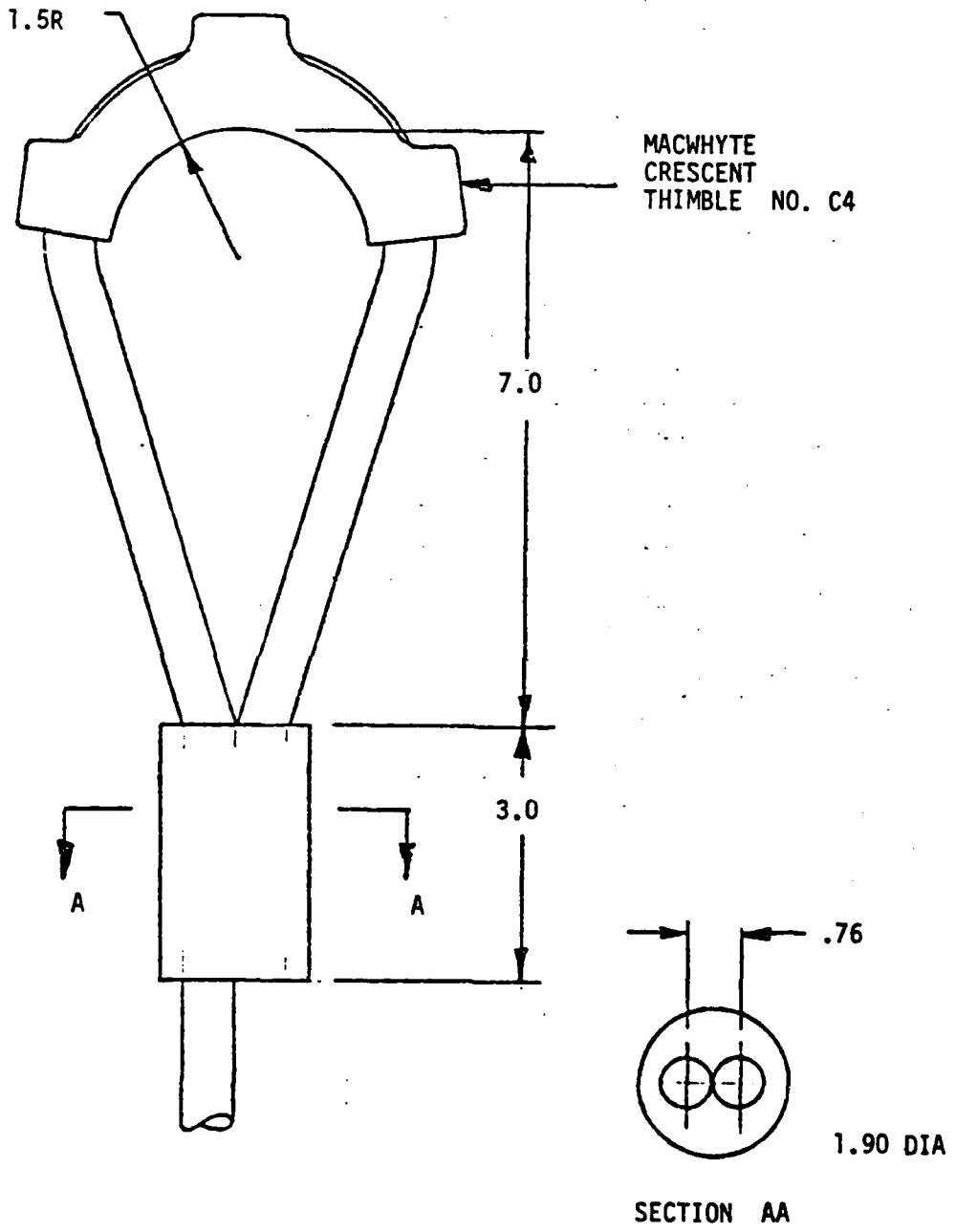
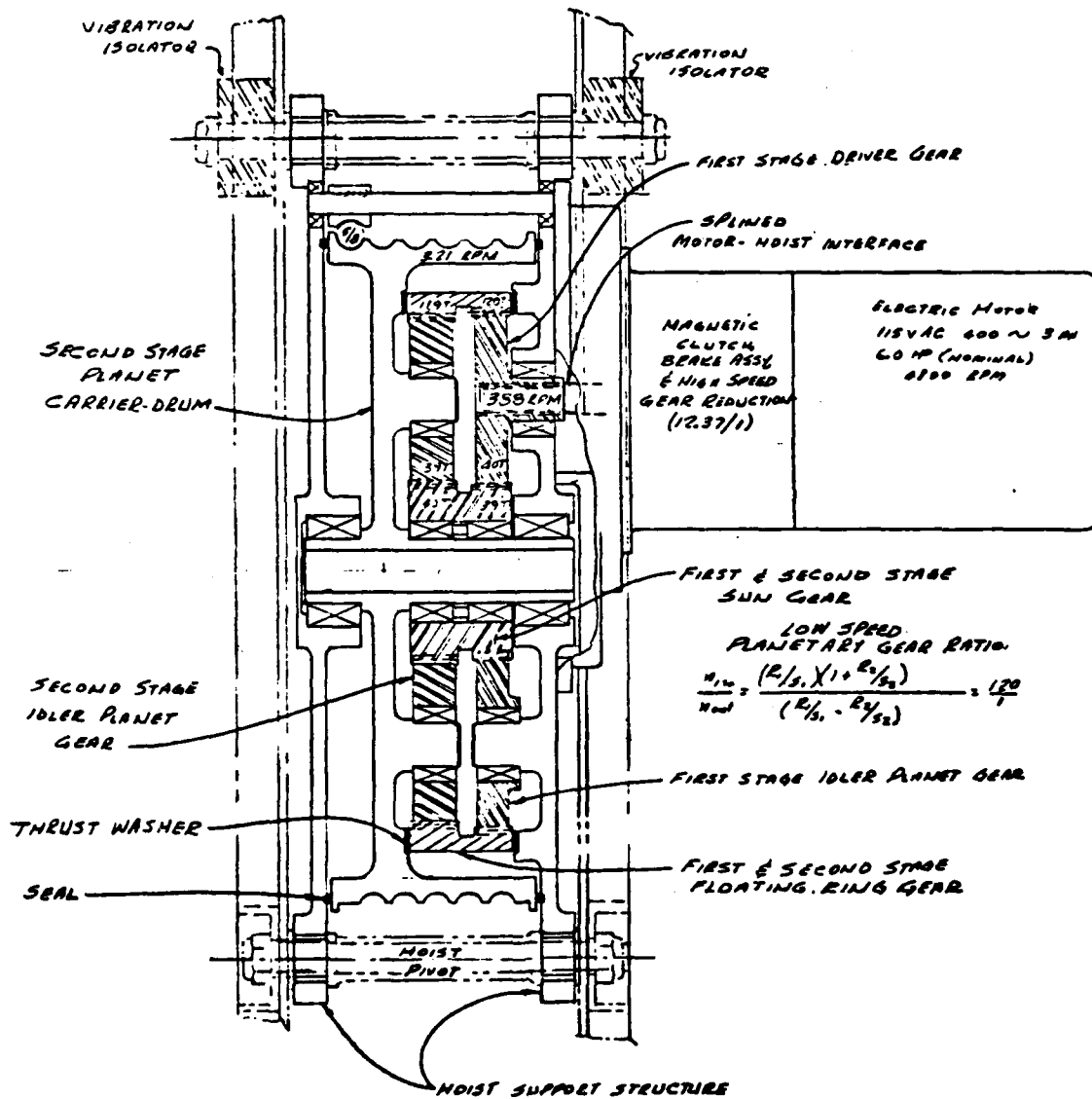

Figure 4.10 Hoist Cable Eye End

BOEING VERTOL CONCEPT



PROBLEM: Low efficiency of this type of differential gearing

Figure 4.11 Hoist Design - Boeing Vertol Concept

BREEZE BL-6700

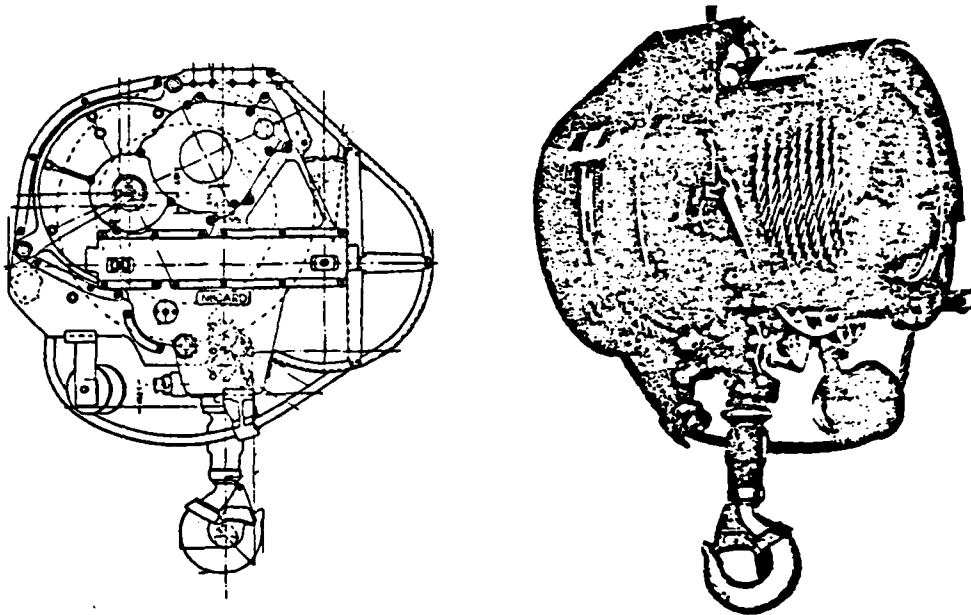

ADVANTAGE: Existing Design

- PROBLEM:
- Envelope Difficult to Integrate Into Structure
 - Requires a Reeved Installation
 - Capacity Limitation
(12,000 lb when reeved vs 20,000 lb required)
 - Requires Modification for Electric Drive

Figure 4.12 Hoist Design - Existing Breeze BL-6700

- 2) The hoist requires to be mounted "upside down", with mounting holes directly in line with the cable payout position. This arrangement results in increased separation between the ECHS and aircraft due to the depth of structure required to incorporate an isolation system.
- 3) The hoist would require modification to change the drive motor from hydraulic to electric.

Use of this hoist would result in a prototype system that would not be representative of an optimum or production type ECHS, and would therefore prevent a meaningful assessment of the total ECHS operational suitability.

Three manufacturers expressed interest in developing a hoist to meet the criteria:

- 1) Western Gear Corporation
- 2) All American Engineering Company
- 3) Breeze Corporation

The Western Gear proposal utilized a developed electric motor (from the C5A Cargo winch), and a differential planetary gear system. The design included a Western type brake for holding the load. Figure 4.13 shows the proposed hoist.

The All American Corporation proposal considered the use of a double spiroid reduction gear that has the merit of simplicity and minimum parts count. The spiroid configuration resulted in an envelope shape that was difficult to integrate into the ECHS structure, and an unacceptably high preliminary weight estimate. Figure 4.14 shows the All American concept.

The Breeze proposal includes an existing developed electric motor, a triple planetary reduction gear, and a Breeze Safety Brake. Figure 4.15 illustrates the Breeze proposal.

On the basis of weight and potential system efficiencies, the Breeze proposal was selected for integration into the ECHS structure. The Breeze Proposal is included as Appendix C of this report.

4.5 VIBRATION ISOLATOR DEVELOPMENT

The need for isolation between the aircraft and the ECHS was established during the Phase I effort. A study determined the isolator stiffness required, and these results are shown in Figure 4.16. (This isolator analysis was described earlier in report Section 3.2).

WESTERN GEAR CONCEPT

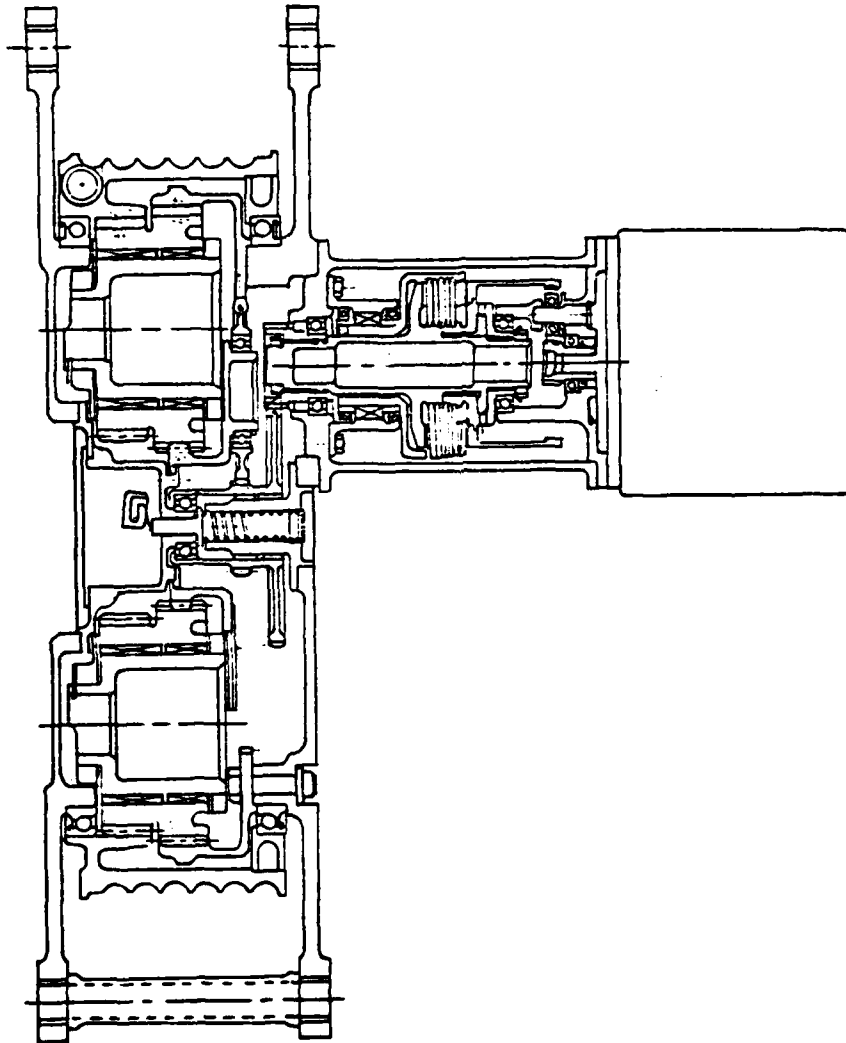

ADVANTAGE: ● Acceptable Envelope
● Developed Motor

PROBLEM: ● Relatively Low Efficiency

Figure 4.13 Hoist Design - Western Gear Concept

ALL AMERICAN ENGINEERING CONCEPT

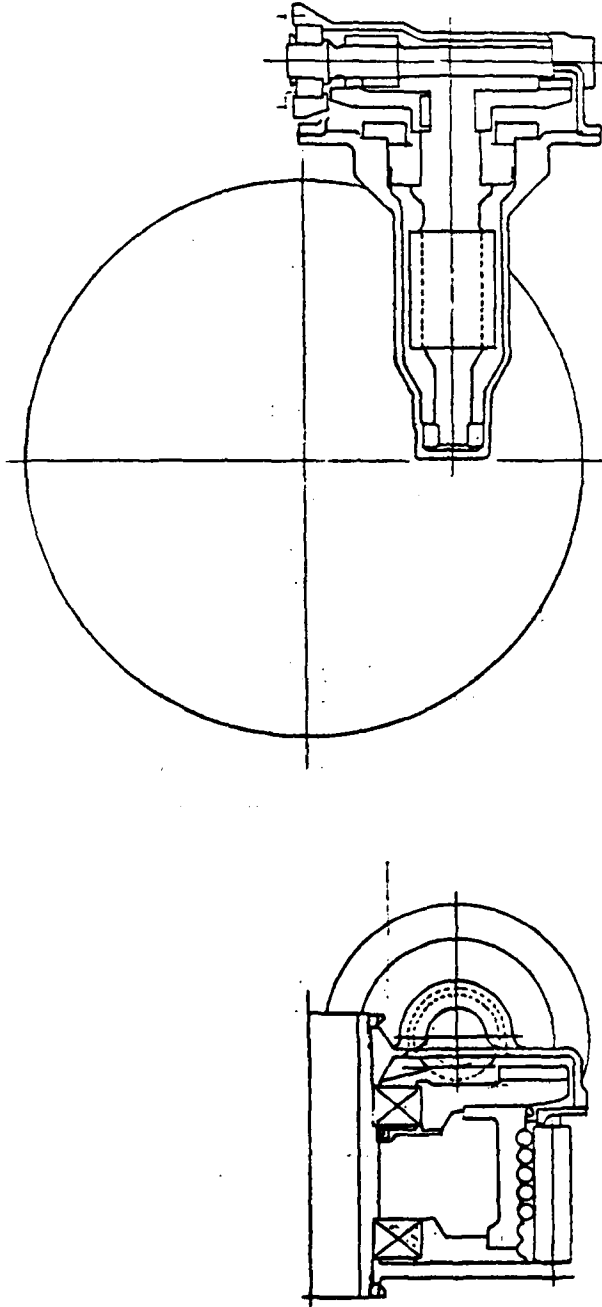

ADVANTAGE: ● Low Parts Count

PROBLEM: ● Low Efficiency

● High Weight

● Envelope Exceeded

Figure 4.14 Hoist Design - All American Concept

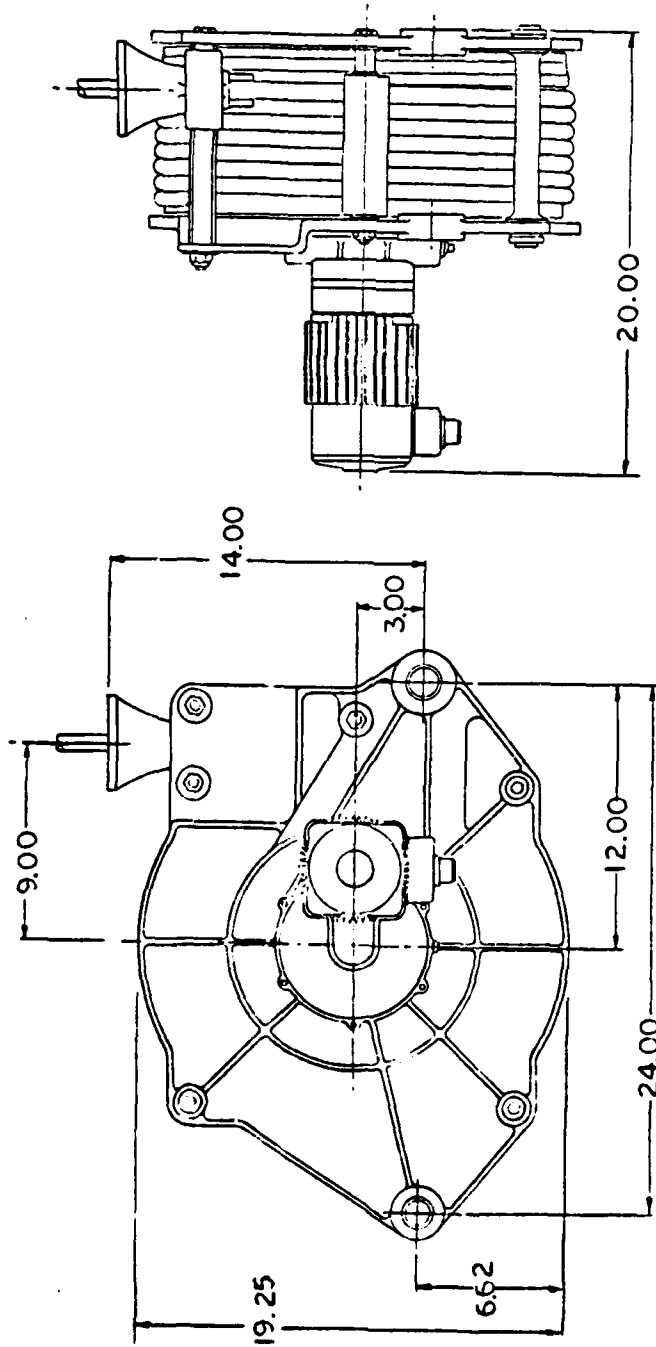
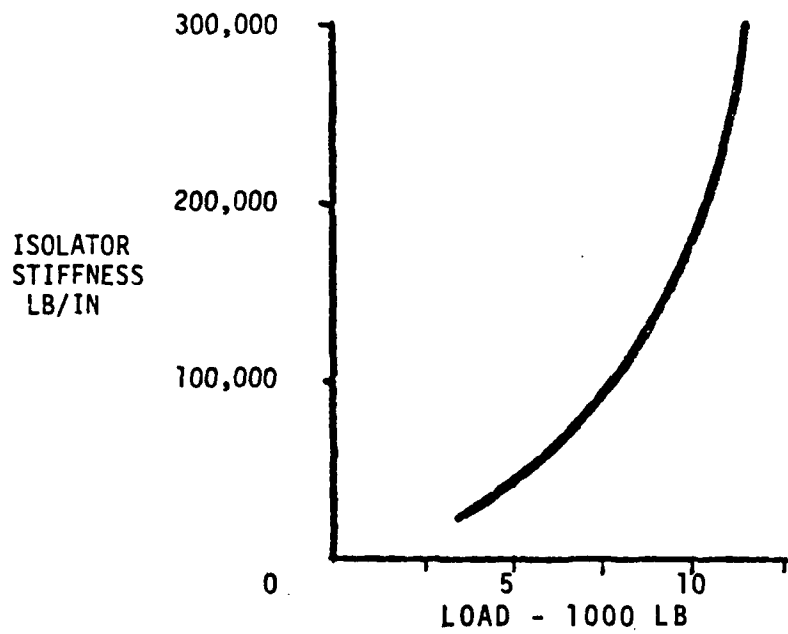

Figure 4.15 Hoist Design - Breeze Concept



ISOLATOR REQUIREMENTS *

*AT CABLE

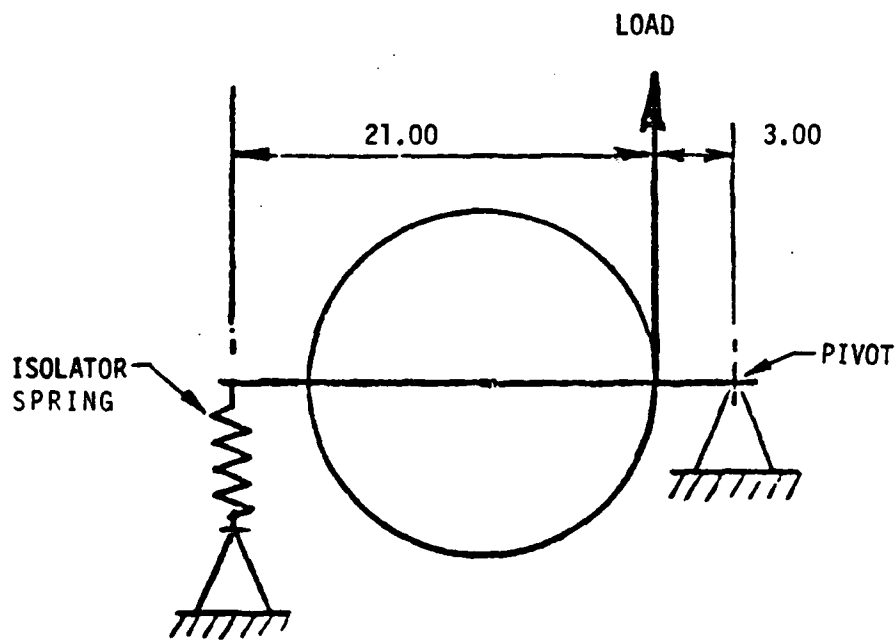

Figure 4.16 Isolator Requirements and Geometry

Several systems were considered including application of liquid spring technology, elastomeric devices, and metallic spring elements. The liquid spring arrangement was rejected as being too complex and expensive when coupled with a suitable temperature compensating device. An elastomeric approach, when arranged with suitable geometry, could possibly provide the isolator requirements. Some development would be required to determine the housing shape and how temperature variations would alter its characteristics. A concept for an elastomeric isolator is shown in Figure 4.17.

The metallic spring appeared to be a practical solution, requiring least new technical developments. Integration of the hoist design with the isolator resulted in development of the geometry shown in Figure 4.16. The moment/arm ratios provide an 8:1 movement amplification at the spring together with 1:8 load reduction, resulting in a 64:1 spring rate reduction. This makes it possible to use a steel spring of reasonable size, and light weight. The spring design is shown in Figure 4.18. This spring provides the characteristics shown in Figure 4.19. While not exactly matching the objective curve, the spring rates do provide the necessary isolation, and at the same time maintain simplicity for ease of fabrication.

The spring definition is as follows:

- .500" diameter CHROM SILICON Wire
- 21 coils
- 3.0" mean diameter
- Initial (free) length 13.02 inch
- First Coil Spacing - .050 inch
- Last Coil Spacing - .389 inch
- Installed Preload Approximately 100 pounds

This spring design demands a constantly changing coil spring, as shown in Figure 4.18. A good approximation for analysis would be to consider several springs of conventional design placed in series.

The design shown here requires the following coil spacing:

<u>Coil Number</u>	<u>Spacing-Inches</u>
Between 1 & 2	.053
3	.056
4	.059
5	.063
6	.067
7	.071
8	.076
9	.082
10	.089

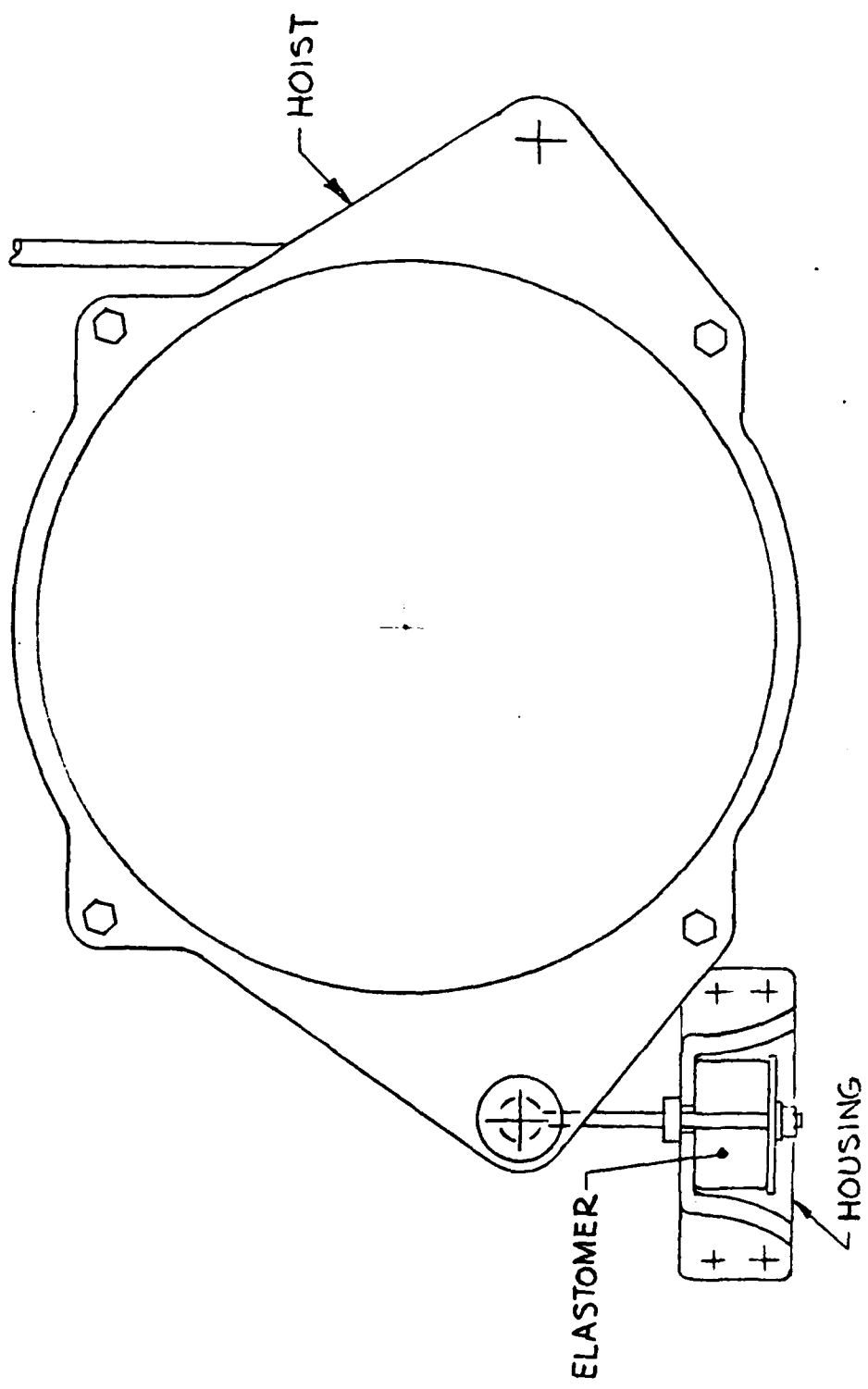

Figure 4.17 Elastomeric Isolator Concept

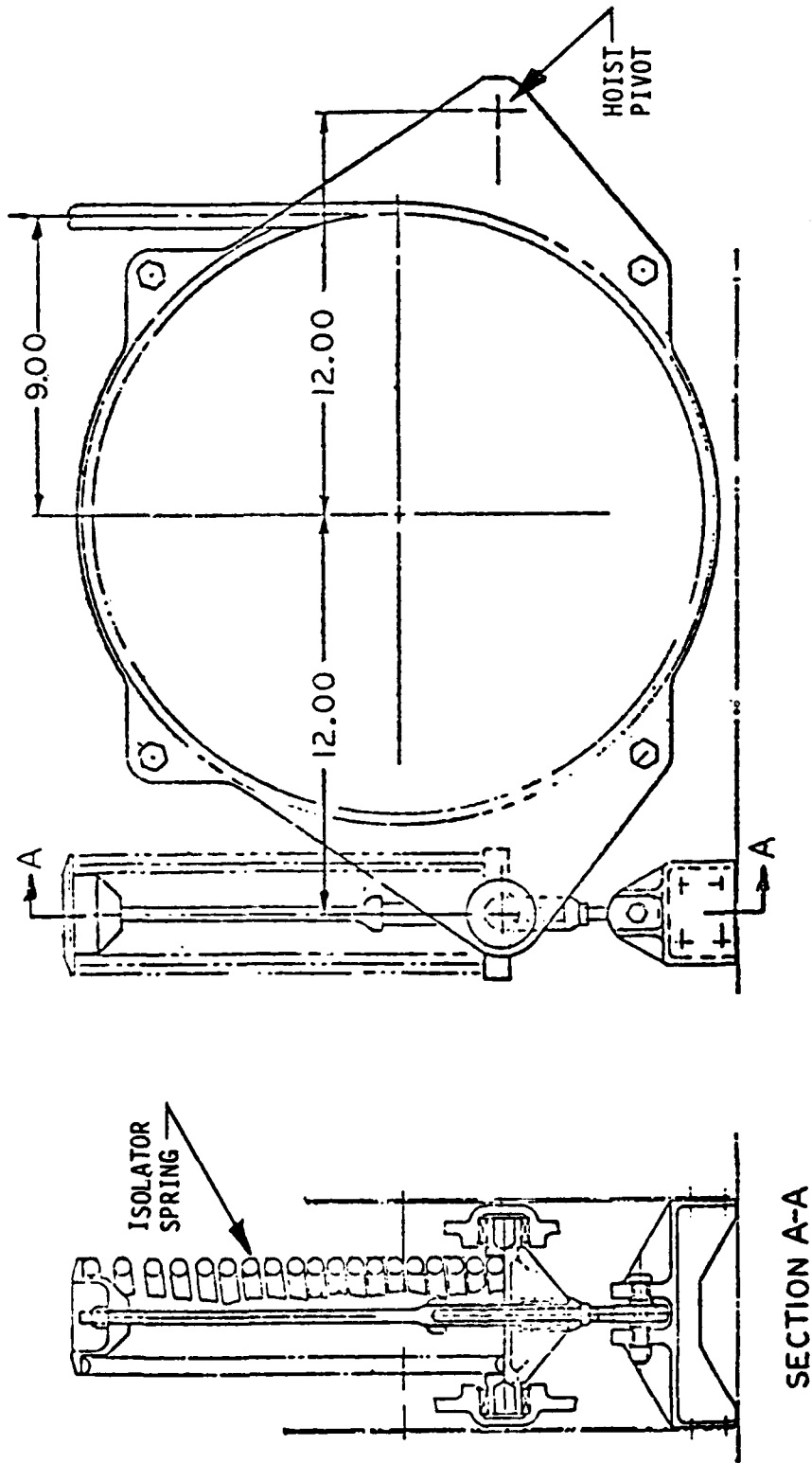

Figure 4.18 Installation of Isolator Spring

67-AU88 057

BOEING VERTOL CO PHILADELPHIA PA
DESIGN AND ANALYSIS OF CH-47 EXTERNAL CARGO HANDLING SYSTEM (SN--ETC(U)
OCT 79 T S GARNETT, R F CAMPBELL, D J HODDER DAAJ02-77-C-0069
D210-11555-1

F/8 1/3

UNCLASSIFIED

NL

2 of 5

NO. 200000

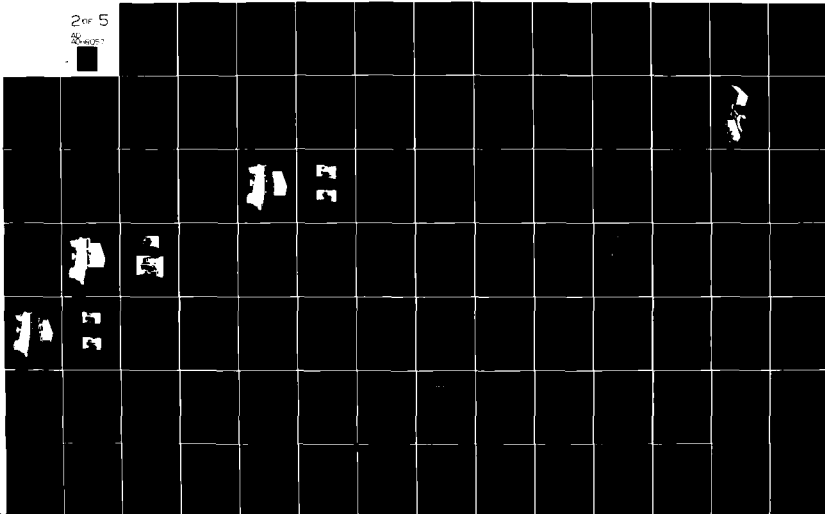

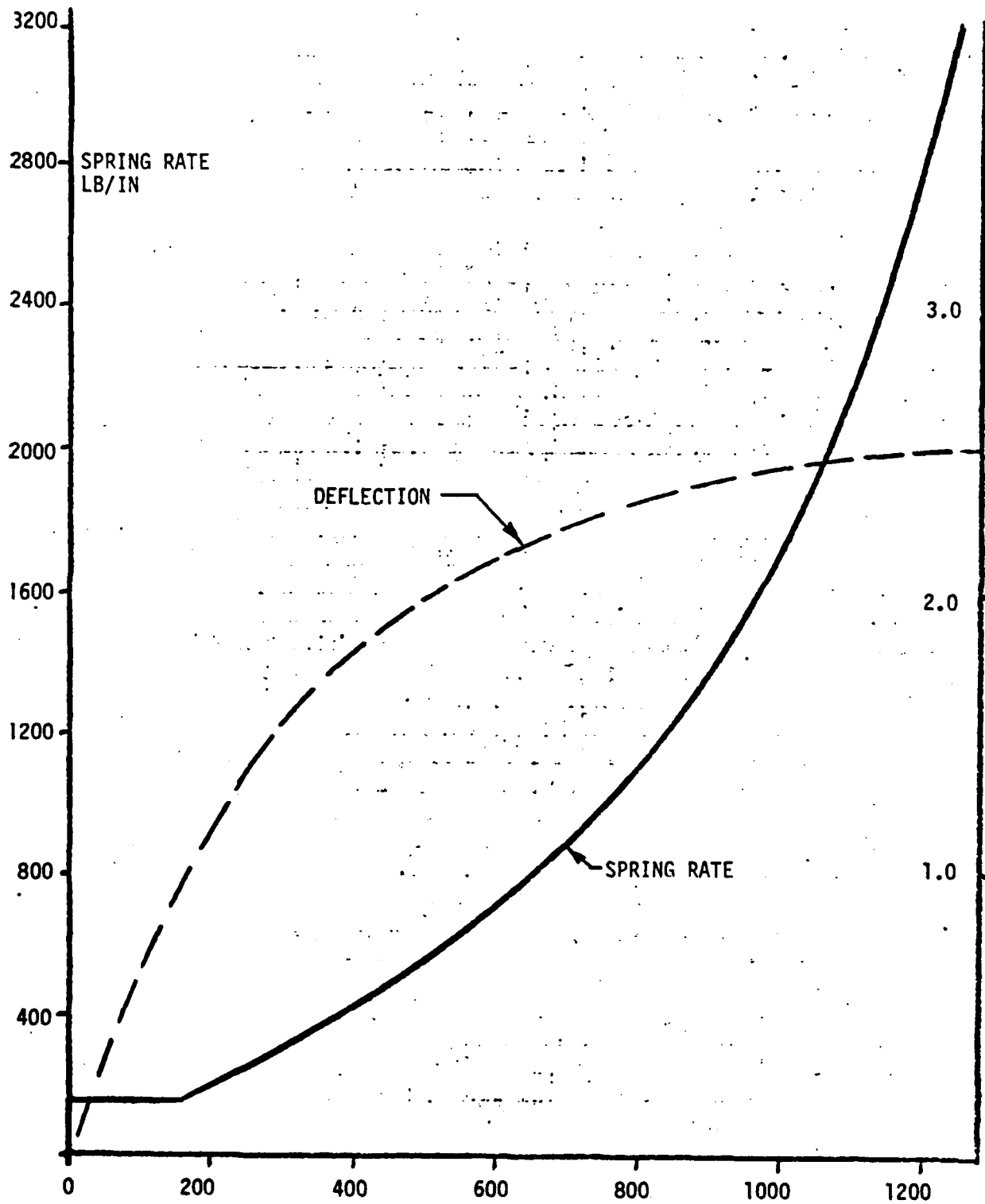

Figure 4.19 Isolator Spring Characteristics

<u>Coil Number</u>	<u>Spacing-Inches</u>
11	.097
12	.107
13	.118
14	.132
15	.149
16	.171
17	.201
18	.241
19	.299
20	.389

4.6 LOAD ACQUISITION AND RELEASE

The load acquisition and release system of the ECHS is derived directly from the system designed for the Container Lift Adapter Helicopter (CLAH), under contracts DAAJ02-76-C-0005 & DAAJ02-77-C-001 (References 3 and 4).

The CLAH design includes a motorized retraction system for the alignment guides. This feature has not been included in the ECHS. The basic concept of spring-element guides retains from the CLAH design a capability for reacting impacts from the load; and still provides the guidance necessary to allow the ECHS to be dropped onto the container or gondola with the twistlocks properly aligned over the receptacles on the load, as required for insertion. The guide arms are tubular steel members shaped to ensure guidance with up to sixteen inches of adapter misalignment.

The six tubular guide arms are arranged with two guides along either long side, and one guide at each end as shown in Figure 4.2.

The two guides along the sides are joined by a torque tube anchored midway between the guide attachments. Impacts are absorbed by bending the guide and also twisting the torque tube. End guides are attached to the center of a torque tube anchored at either end. Tubes are approximately 2.0 inches dia., with a .125 inch wall thickness. A production design should consider a graphite composite tape-wound guide tube for reduced weight, while retaining similar spring rates.

The twistlock acquisition system to secure the adapter to the container is shown on Figures 4.20 and 4.21. Figure 4.20 illustrates the arrangement of the twistlock actuator, with a push-pull rod interconnecting system operating all four twistlocks. Figure 4.21 shows a section through the twistlock housing. The twistlock rotates about a vertical retention bolt secured to the twistlock housing. The twistlock is driven by a

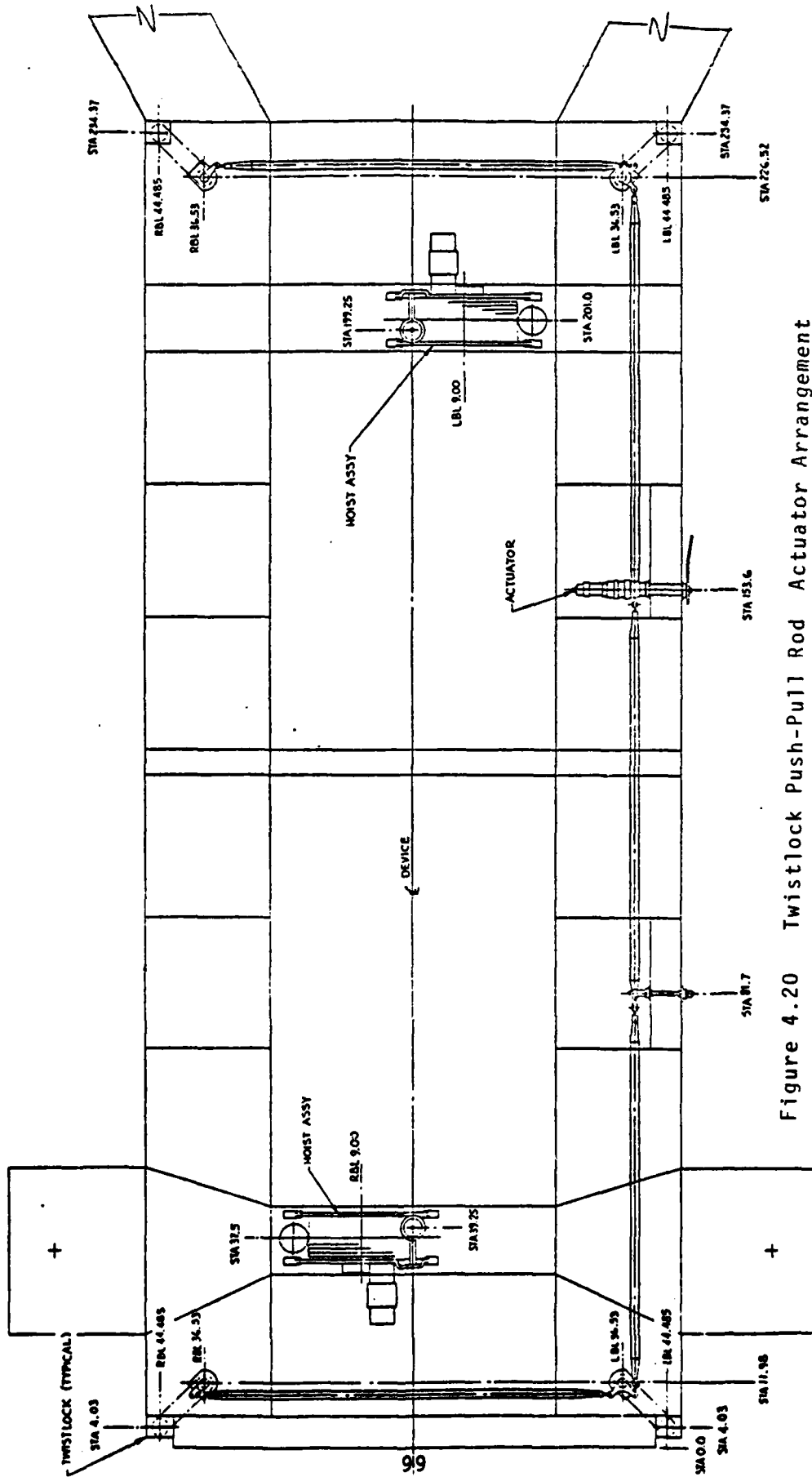

Figure 4.20 Twistlock Push-Pull Rod Actuator Arrangement

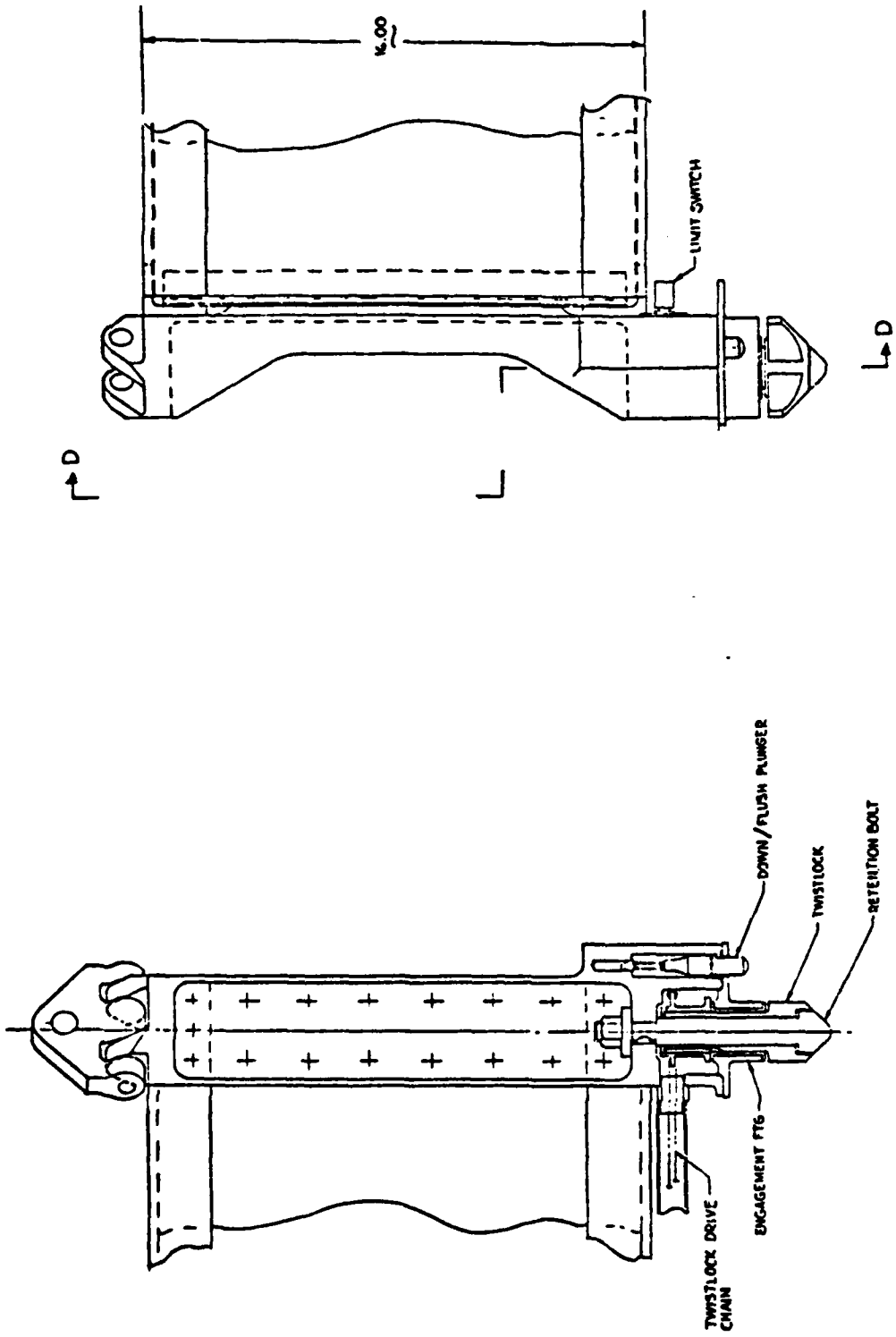

Figure 4.21 Twistlock Housing

chain & sprocket system activated by the push-pull rods attached to a bellcrank mounted inboard of the twistlock housing.

A rotary actuator is mounted on a flange of a shaft along the adapter side, such that removal of a locking pin allows the shaft to be rotated through a hand lever, thus driving the push-pull rods. This provides a back-up capability to operate the twistlocks from the ground in the event of an inoperable electrical system.

A push rod projecting from the underside of the twistlock housing activates a switch when the ECHS is fully down on the load. This switch provides a signal allowing the twistlocks to be operated - closed or open (see Figure 4.22). In operation, a switch activating cam on the twistlock shaft causes an electrical switch mounted to the twistlock housing to provide indication (via a light on the control panel) of the "locked" or "unlocked" condition (see Figure 4.23).

Guide System Criteria

- The guide shape, length and locations shall be as shown on Figure 4.2 for the demonstration ECHS.
- The guide system shall be considered as a structural spring, storing energy due to any impact, and releasing that energy in returning to a normal position.
- The guide shall be designed to accept a minimum strike velocity of 4.0 feet/second in the longitudinal, lateral or vertical direction.
- The load at the end of the guide that results from the impact velocity of 4.0 feet/second shall be considered the limit load. Ultimate load shall be 1.5 X limit load.
- Guide tube attachments shall be designed for an ultimate load of 2.0 X limit load.
- Guides shall be interchangeable and readily replaceable.

Twistlock System Criteria

- The twistlock geometry shall be compatible with the American National Standard Specification for International (ISO) Freight Containers, ANSI ME5.4-1972.

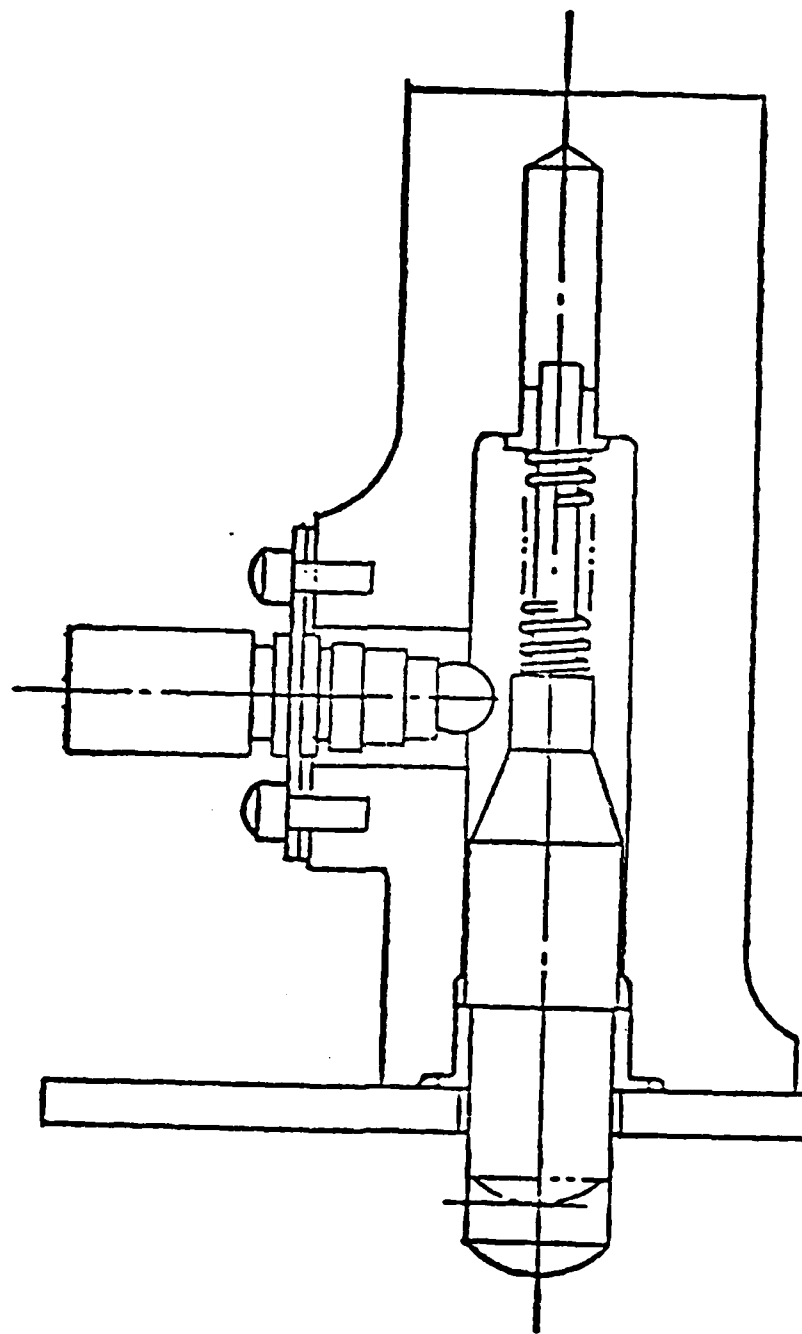

SECTION THROUGH TWISTLOCK HOUSING
TYP. 4 PLACES

Figure 4.22 Interlock Plunger Switch

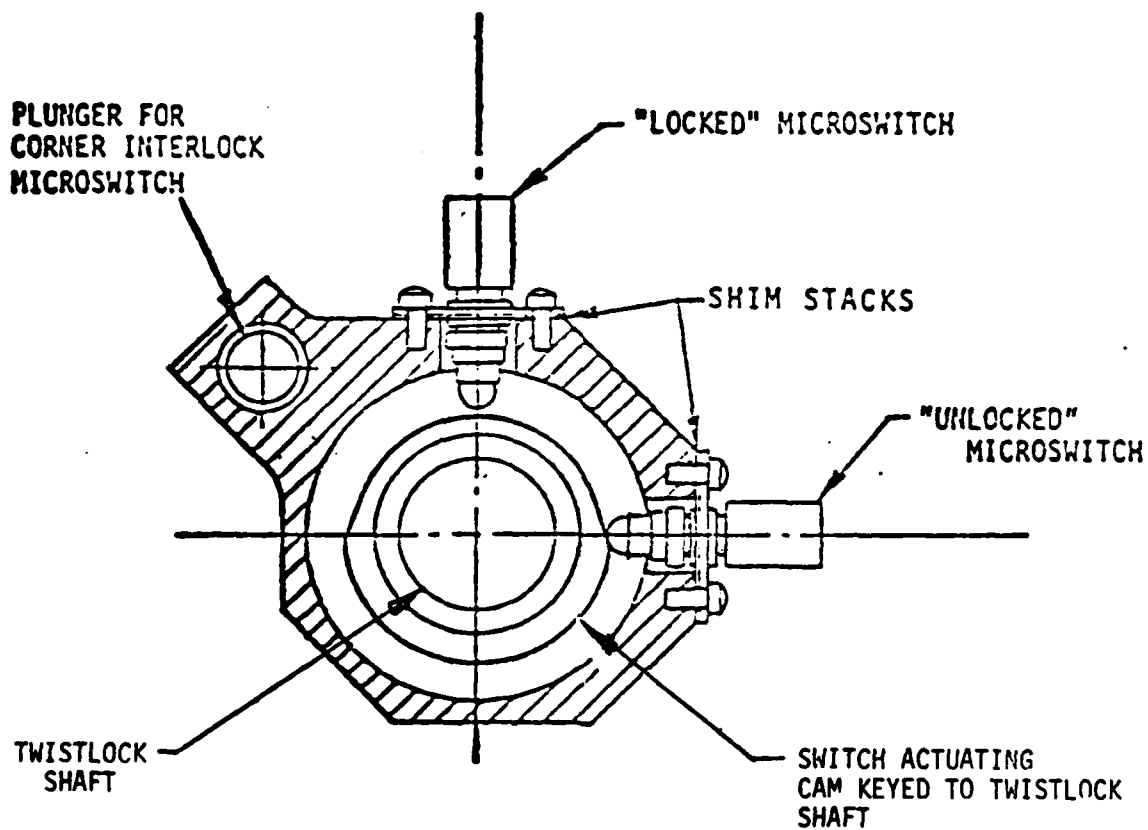

SECTION THROUGH TWISTLOCK HOUSING

Figure 4.23 Twistlock Position Indicators

- The twistlock system shall operate from locked to unlocked, or from unlocked to locked within one second.
- The twistlock actuator shall have a design torque of 250 in-lbs minimum at the design speed above.
- The twistlock actuator shall have a minimum stall torque of 500 in-lbs.
- The twistlock actuator shall require a 200 VAC
 - 400 cycle 3 ph electrical supply

NOTE: Plessey actuator Part No. M422M12 fulfills the above requirements.

- The hand lever shall not require more than 20 pounds effort at the end of the lever to lock or unlock the system.
- The twistlock control circuit shall have an electrical interlock such that the actuator cannot operate until the ECHS is correctly positioned onto the load. Figure 4.22 illustrates the plunger/switch arrangement, typical at all four corners of the ECHS. Twistlock alignment limits shall be as shown in Figure 4.24.
- Each twistlock shall have switches to indicate the position of the twistlock. Figure 4.23 shows the switch arrangement.

4.7 ELECTRICAL SYSTEM

The ECHS electrical system is supplied with the necessary AC DC power from the CH-47 aircraft. AC power cables and DC control wiring form an umbilical cable that connects between break-away fittings installed at the aircraft hatch, and a junction box mounted on the ECHS. The power cables in the aircraft connect to the two AC distribution panels in the cockpit. The DC wiring connects to an outlet in the cabin at approximately Station 350. A hoist speed control box and system control panel are portable carry-on units located in the cabin at the hatch. Figure 4.25 illustrates the system concept.

Extra slack in the umbilical cable may be wound on a spring-powered storage reel located on the ECHS. An alternative consideration is to pre-coil the cables to eliminate the need for the storage reel.

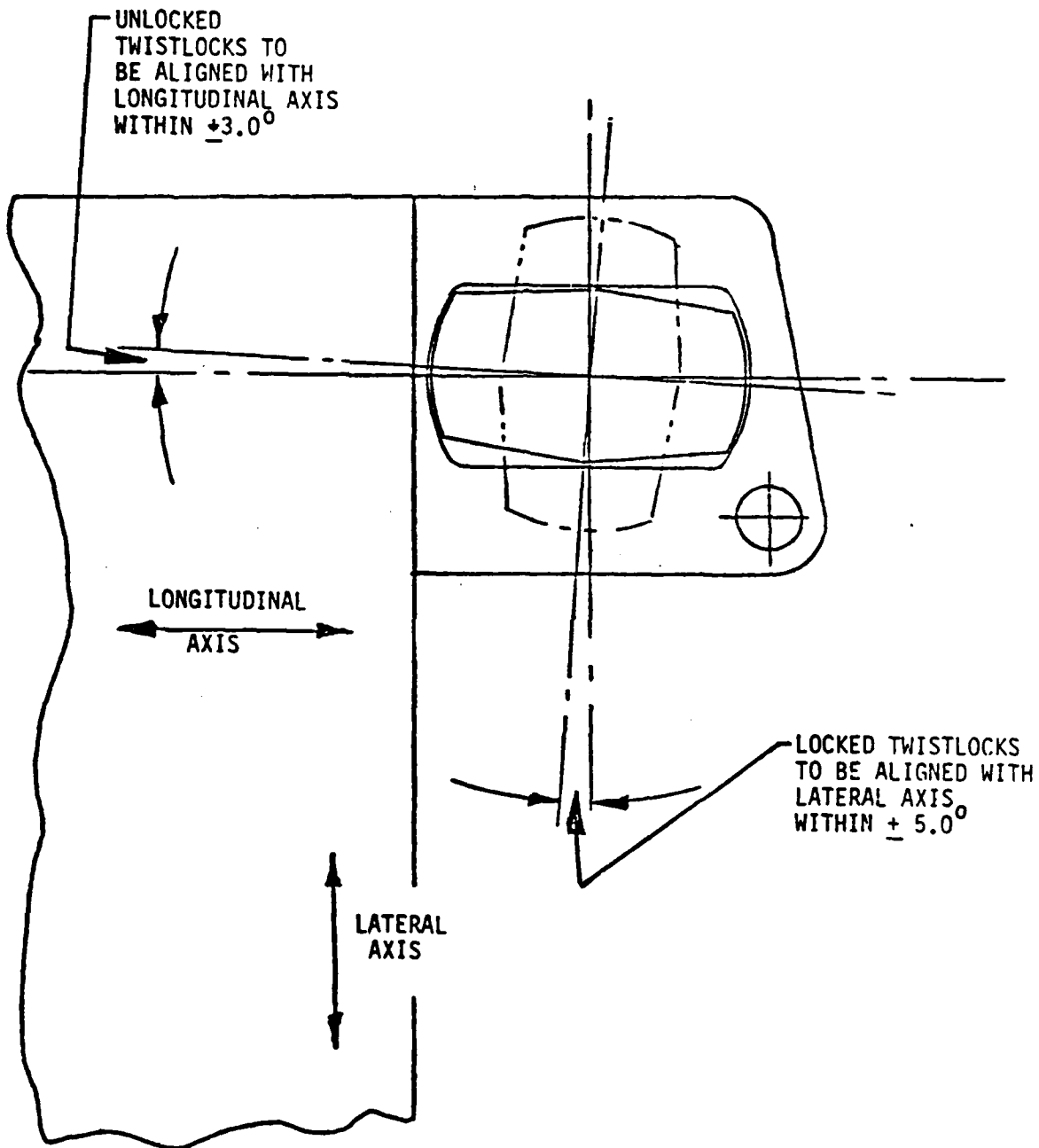

Figure 4.24 Twistlock Alignment Limits

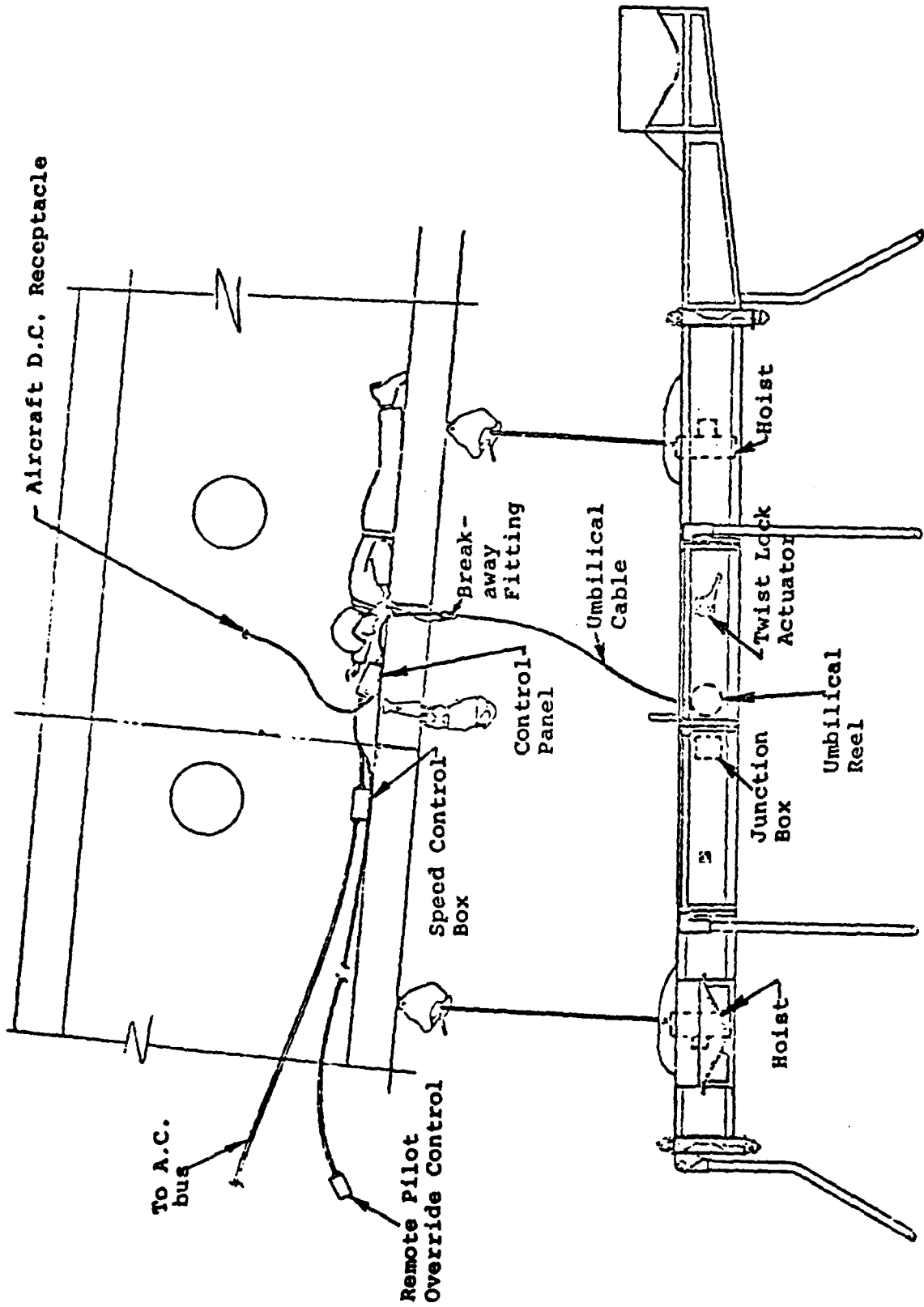

Figure 4.25 Electrical System Concept

The control panel is shown on Figure 4.26. This panel has the following controls and indicators:

- Power "on-off" switch
- Power "on" indicator
- Twistlocks "locked-unlocked" switch
- Corner interlock "down" indicator
- Corner interlock "not down" indicator
- Twistlocks "locked" indicator
- Twistlocks "unlocked" indicator
- Hoist select switch - fwd, both, aft (normally "both")
- Hoist control "up-down" switch
- Load snubbed indicator
- Hoist lower override switch
- Hoist "safe-to-lift" indicator

The hoist motor control system shall be designed to produce a differential speed capability between the two hoists, so that when fully out (under load) the forward hoist has approximately 19 inches more cable deployed than the aft hoist. This differential will permit the ECHS to be approximately level when the aircraft is in hover, and lined up with the landing gear when raised to the aircraft. An override hoist control is installed on an extension cable from the control panel, allowing emergency operation from the cockpit.

An additional electrical system interconnect to the aircraft (discussed later) provides capability for the landing gear squat switch signal to the AFCS to be disabled during load snubbing operations.

System Operation

With all cables connected and the aircraft power on, the crewman may activate the ECHS system by moving the Power Switch to "on". The power on indicator will be lit, the twistlock "unlocked" indicator will be lit, and the corner interlock "not down" indicator will be lit. The twistlocks cannot operate in this configuration until all four corner interlock switches are activated. These switches provide an electrical lock preventing the twistlocks from being powered, until the adapter is completely down and properly aligned on the container.

If the ECHS is suspended with over 12 ft of cable reeled off the hoists, the helicopter must first lift the unloaded device before a load can be acquired and lifted. The crewman selects "Hoist Override Up" to power the hoists. The hoists will be stopped by the hoist limit switches when there is approx. 12 ft of cable deployed, and the ECHS is now ready to acquire a load.

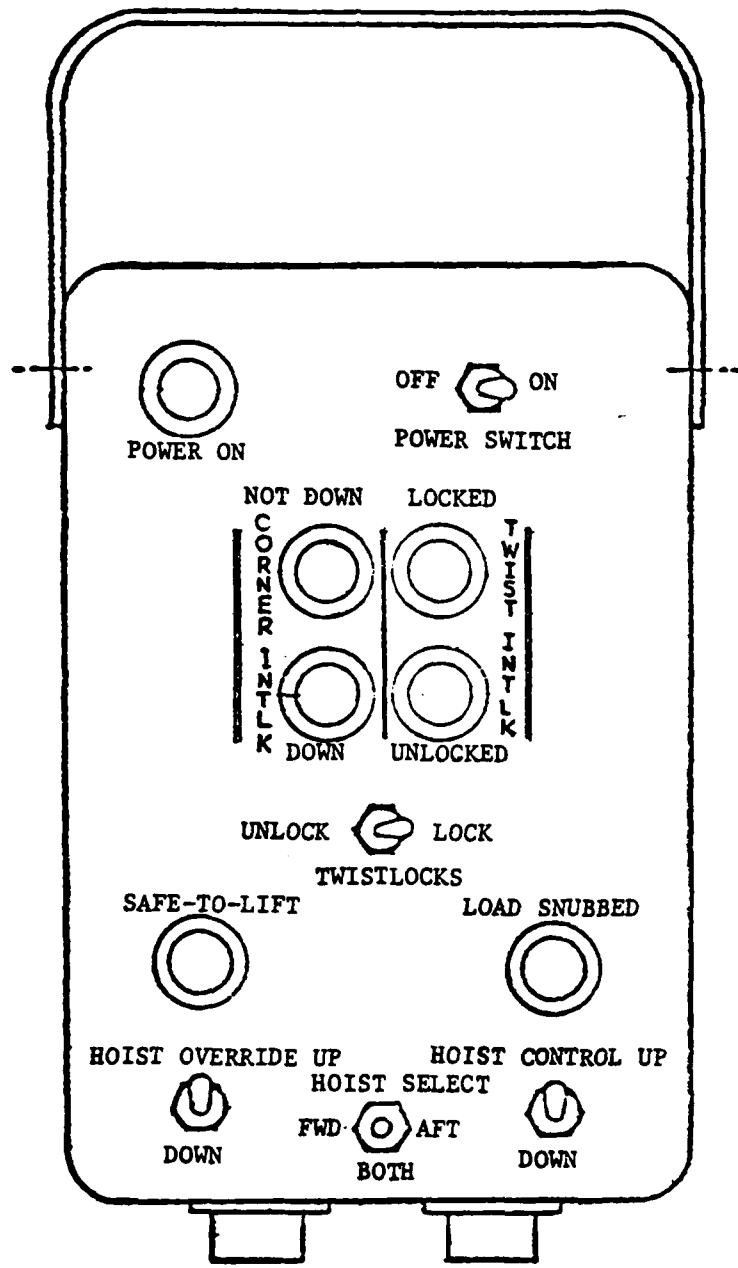

Figure 4.26 Electrical Control Panel

The helicopter positions the ECHS over the load and descends until the weight of the adapter is supported by the top of the container. The guides will have positioned the twistlocks above the container receptacles, and the interlock switch will be actuated; as indicated by the corner interlock "Down" indicator being lit, and the "not down" indicator now being out. The crewman selects "Twistlock Lock" at the control panel. The twistlock actuator is energized, rotating all four twistlocks through 90° into the locked position.

The cam on the twistlock will actuate the switch to indicate that the twistlocks are locked (see Figure 4.23), thereby releasing the "unlocked" switch. With all four twistlock switches actuated, the twistlock "Locked" indicator will be lit, and the unlocked indicator will be out, and power will be removed from the twistlock actuator. The "Safe-to-Lift" indicator now lights. This indicator requires both the hoist override to be in the up position, and the twistlocks locked, to show a safe condition.

The helicopter may now lift the load clear of the ground, and the crewman can select "Hoist Control Up"; powering the two hoists through the speed control unit. The hoists will bring the load to the landing gear in approx. 60 seconds. When the load is lifted off the ground, the corner interlock light will change from "down" to "not-down", and remain so until the load is again on the ground and the weight of the ECHS is supported by the top of the container.

Each landing gear pad has a switch controlled by the pressure of the aircraft tire against an actuating pad (or treadle) which shuts down the hoists as the ECHS reaches its snubbed position. Figure 4.27 shows the switch/treadle concept. The switch will be set to activate when the nominal pre-load on the landing gear is approximately 1250 lb. Due to drag and negative lift (of the snubbed load) which increases the up-load on the aft landing gear (and decreases it on the forward gear) in normal forward flight, the forward gear pad switches will probably have to be biased to actuate at approximately 1650 lb, and the aft landing gear pad switches at approximately 850 lb for hoist shut-off.

When the two forward landing gear pad switches are actuated, power to the forward hoist will be removed, and when the aft landing gear pad switches are actuated, power to the aft hoist will be removed. The hoists will have independent limit switches set to actuate if there is a failure of any of the landing gear pad switches.

With power removed from the hoists (after snubbing), the "Load Snubbed" indicator on the control panel will be lit and the actuator for the center hook Safety latch will be powered

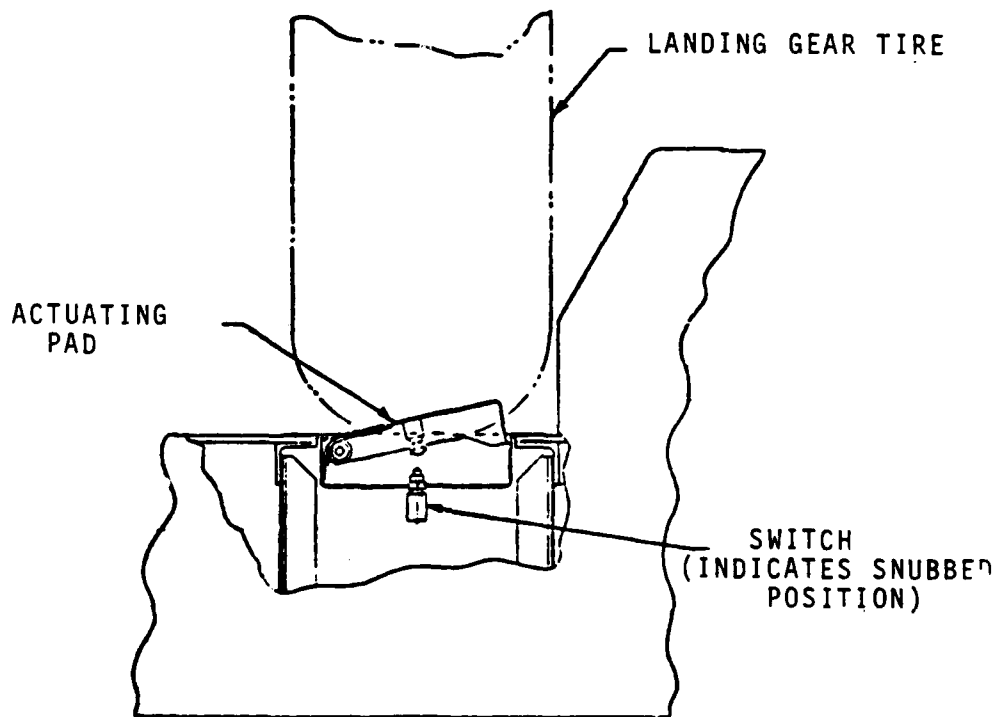
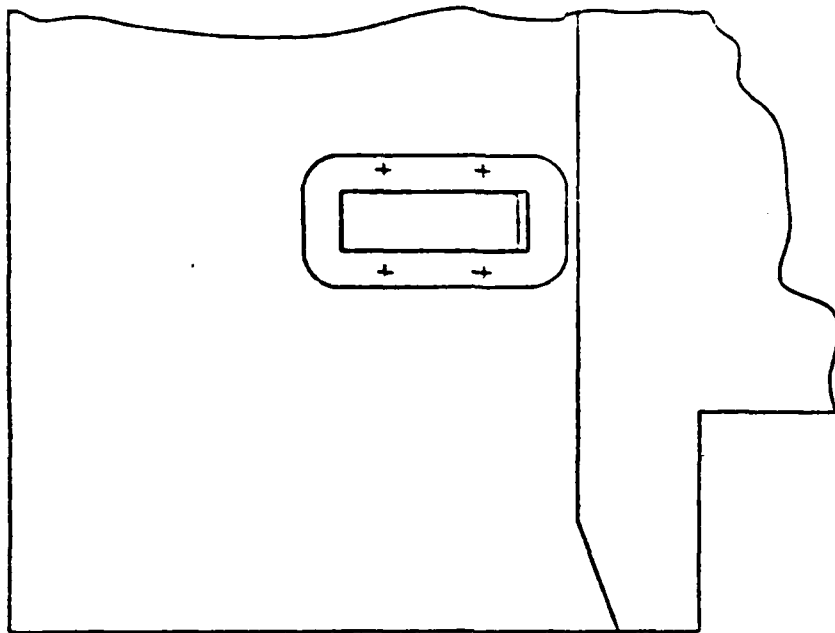

Figure 4.27 Landing Gear Pad Switch

to close the latch about the center hook load beam. This may be visually checked by the crewman through the hatch.

Deposit of the load is accomplished by a reversal of the acquisition procedure.

AFCS/Landing-Gear Squat Switch - Disable Function

It is probable that an override circuit for the landing gear squat switch (AFCS interlock) will be necessary for the ECHS. The circuit will be designed such that the squat switch would be ineffective while that ECHS is snubbed to the aircraft. In normal aircraft operation, this switch sends a signal to the aircraft AFCS which changes system function when the aircraft is in contact with the ground. Two inches of oleo deflection (from the full down position) activate the switch. Although oleo compression with the load snubbed will usually fall between 0.5 and 0.8 inches for static flight conditions (with the nominal 1250 lb pre-load established), values in excess of 2.0 inches may occur during the execution of terrain avoidance maneuvers.

4.8 AIRFRAME/AIRCRAFT MODIFICATIONS

A major objective of this program was to limit changes to the CH-47D aircraft. Basically, this objective has been met as there are no structural changes required to the aircraft, whatsoever, and systems changes are limited to the provision of power take-offs from the AC bus.

Most likely it will be necessary to provide an override circuit for the landing gear squat-switch interconnection into the aircraft AFCS. Detailed analysis, or fly-tests, are required to determine if oleo deflections are sufficient to activate the squat switch (described earlier) during flight with the ECHS. The circuit would be designed so that the squat-switch signal to the AFCS would be disabled while the ECHS is snubbed to the aircraft.

For normal operation with the ECHS, the control panel and hoist control box would need to be positioned in the cabin first, and then secured to existing floor tie-down fittings. The fixed portion of the umbilical break-away fitting would also be connected to a tie-down ring.

The remote override hoist control box would be located in the aircraft cockpit and the AC power cable connected to the AC bus, along with the AFCS/gear squat switch connection if required. DC control power would be available through a standard cabin outlet. An electrical schematic showing required system interfacing with the aircraft is presented in Figure 4.25. All necessary aircraft modifications are summarized in Table 4.4. The only remaining aircraft system functions

AIRCRAFT MODIFICATION KIT

- NO STRUCTURAL MODS
- CARRY-ON KIT:
 - Speed Control Unit
 - Control Panels
 - 1. Cabin (Crew Chief)
 - 2. Cockpit (Pilot Override)
 - Electrical Cables
- AC POWER RECEPTACLES
- SAS SQUAT SWITCH - AFCS SIGNAL
DISABLE INTERCONNECT

Table 4.4 Aircraft Modification Summary

required for use with the ECHS snubbing device are the center cargo hook hatch (which would need to be open), and the position of the center hook which must be deployed down and ready for use, prior to ECHS hook-up.

4.9 SNUBBED LOAD DYNAMICS (AIR RESONANCE)

In addition to the vibration isolation design effort described in Section 3.2, a preliminary analysis of the snubbing-against-the-landing gear concept was made; in order to determine its potential for inducing (or suffering from) air-resonance problems. Results of this evaluation were favorable, as satisfactory levels of damping were predicted for all load and airframe degrees of freedom investigated.

A six degree of freedom, small perturbation math model was used to simulate the coupled aircraft/load lateral motions. These motions included two rotor blade degrees of freedom (flap and lag), two aircraft modes (roll and lateral translation), and two external load modes (roll and lateral translation). The rotor blade modes included the steady and two cyclic components; with flap (β_0 coning, and b_1 and a_1 longitudinal and lateral flapping considered) and a steady lag angle, with two cyclic elements considered.

The basic math model was synthesized from the more complex Boeing Vertol C-59 Air Resonance computer program, and treats the tandem rotor system as a single rotor for modeling purposes.

Results of the air resonance model analysis were in the form of eigenvalues for the coupled load/airframe system. Utilizing the damping provided by the landing gear oleo struts, along with an assumed 1% of critical structural damping across system components, the roll/lateral translation modes were the only investigated (because of their critical nature relative to air resonance stability). Stability roots for the system indicated that the oscillatory roll mode of the load was driven into two stable aperiodic modes, while the oscillatory lateral load (sway) mode ended up with 6% of critical modal damping.

The coupled yaw and pitch/vertical or longitudinal degrees of freedom were not investigated because of the preliminary nature of the analysis, and because these modes are thought to be non-critical to the system, as presently conceived. Detail air-resonance investigations were not carried out at this stage of preliminary design development, but should be performed in some depth, when final prototype designs are completed in the future. At that time, analysis of air-resonance stability for the prototype or detail design system should include items such as the structural stiffness of the

adapter, and additional coupled airframe and load degrees of freedom which require treatment to ensure system safety.

4.10 SAFETY AND EMERGENCY OPERATION

A key design feature of the ECHS is the redundant center hook attachment latch that operates when the adapter is snubbed.

The latch geometry provides sufficient clearance around the hook during normal operation to avoid any effect on the isolation system. A failure or inadvertent opening of a hook on the aircraft, or hoist failure on the ECHS, will result in the center hook latch retaining the load. The load, complete with ECHS, must then be released from the aircraft by opening the hooks while the helicopter hovers close to the ground.

Load jettison in flight may be accomplished by opening the aircraft cargo hooks. Operating the aircraft cargo hook emergency release switch in the cockpit will open all three hooks. Jettison from the cabin is also possible by using the manual release system. The center hook manual release must be operated first, then the manual release lever for the forward and aft hooks. When the hooks open, the load, complete with the ECHS, will fall away from the helicopter. The umbilical cord will separate at the break-away connector.

Failure of the hoisting system during acquisition or deposit of the load will require load release by opening the aircraft hooks.

The ECHS may be used as a suspended device with the hoists inoperative, by attaching standard Army slings to the four attachment fittings located directly above the twistlocks. These points are rated for the maximum load. For suspended flight, the ECHS must be rigged in a 10° nose down attitude relative to the aircraft, to provide required directional stability of the load.

4.11 COSTS AND WEIGHTS

4.11.1 Cost Estimate

The ECHS preliminary design has been reviewed to establish an order-of-magnitude price for two systems. Some areas of the design have enough definition for a detailed estimate; while other areas have used parametric techniques to establish potential costs.

The estimates lean heavily on the cost experience with the Container Lift Adapter-Helicopter (CLAH) and are presented here as a function of CLAH costs. (See Reference 10,

DAAK-51-78-Q-0069-Proposal for Fabrication and Testing of a Container Lift Adapter Helicopter.) These order-of-magnitude costs reflect fabrication by Boeing Vertol or established sub-contractors as appropriate for economic production. Hoist cost data reflect hoist design and fabrication by Breeze Corporation for the design as proposed in Appendix C.

Figure 4.28 provides order-of-magnitude costs for various quantities of ECHS systems relative to the unit cost of the first two CLAH adapters. Figure 4.29 provides an approximate percentage breakdown of the production costs for the first two ECHS.

These estimates assume that the prototype design would continue to be produced, and do not reflect possible Design-to-Cost activities that could be introduced for a production program. The projected weights for a production design consider composite structures that would influence production costs. Projected costs for composite type production structures are generally lower than for conventional structures.

The following table projects non-recurring costs for the ECHS, again presented as a function of CLAH costs. Here the CLAH costs are for the two phases of design, structure and interface design.

	<u>Cost Ratio</u>
Design of CLAH (Baseline)	1.0
Detail Design of ECHS including Hoists	1.8
Tooling	0.8
Qualification Testing including Test Units (1 Hoist + 1 Structure)	2.0

4.11.2 Weights

Estimated weight of the ECHS preliminary design, and as projected for production (in composite materials), is shown in Table 4.5.

Production weights are based upon a detailed estimate of the preliminary design, including both the structure and hoists. The electrical system weight is based upon a modification of the CLAH system.

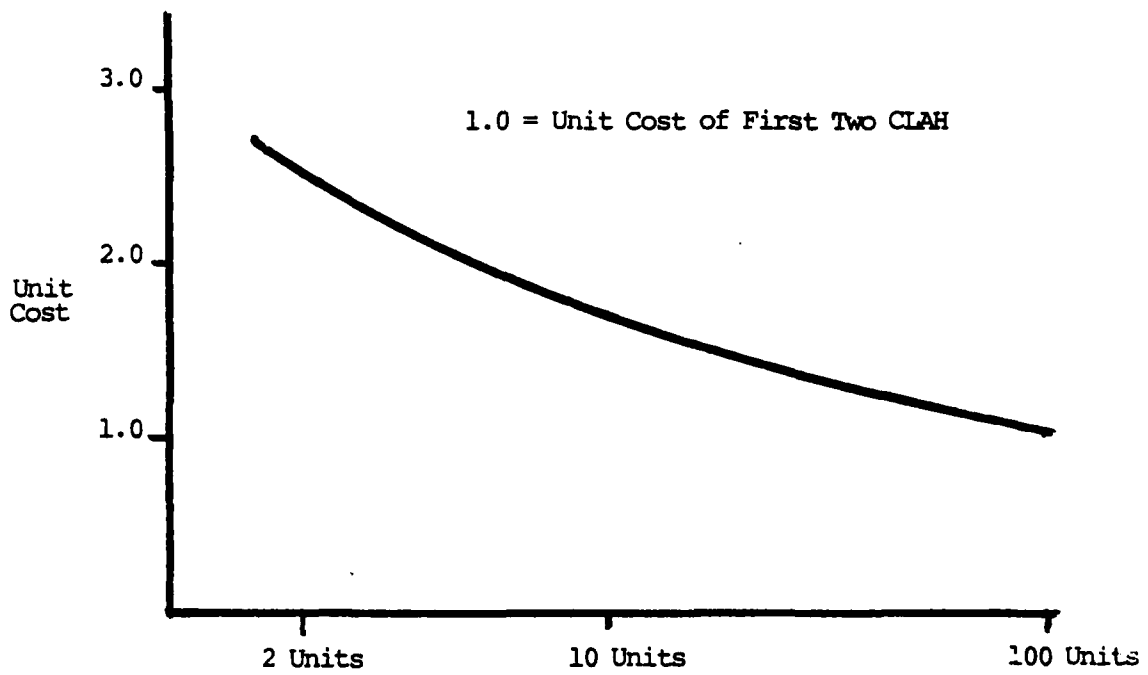

Figure 4.28 Order-of-Magnitude Costs for ECHS

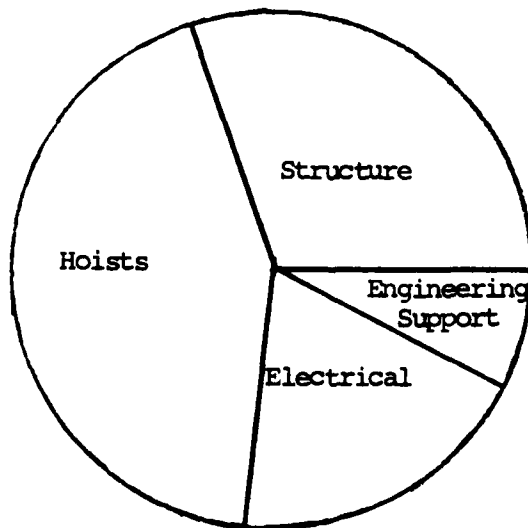

Figure 4.29 Production Cost Breakdown - Initial Two Units

WEIGHT ESTIMATE

ECHS		
	Prototype	Production
Structure	850	640
Twistlock System	110	95
Guide System	190	95
Hoists	480	400
Cables	60	48
Isolators	33	33
Electrical	100	100
Misc. Hardware	50	50
TOTAL	1873	1461

Use of Kevlar
Graphite Tubes
Graphite Wound
Alum. Drum
Reduce Dia.

Weight of CLAH & SLINGS (Fixed Guides) = 903

SNUBBING DELTA - 970 PROTOTYPE DESIGN
558 PRODUCTION DESIGN

Table 4.5 Projected Weights for ECHS

The projected weights for the production design reflect a parametric reduction of 25% in the structural weight. This factor is typical of Boeing Vertol experience in converting structural designs from skin & stringer to composite construction. The weight reduction in the guide system is shown as 50%, where wound composite tubes allow tapering of the diameter to reflect an optimum design.

The projected production hoist & cable weight reductions are based upon using new hoist cables designed for a 60,000 lb ultimate strength using technology developed during the HLH program (Reference 5 report USAAMRDL-TR-74-97A).

For proper prospective these weights must also be considered relative to the CLAH; as the ECHS can accomplish all the tasks possible with the CLAH, plus the self-hoisting and snubbing functions required for terrain flying. Deducting the weight of the CLAH plus its slings, results in a snubbing delta of 970 lbs for the prototype units, and 558 lbs for the production units, when compared to conventional suspension methods which will be used in the future.

5.0 PHASE IV - CH-47 LOAD SNUBBING WIND TUNNEL RESULTS ANALYSIS

In September 1978, the basic snub load developmental contract (Reference 2) was augmented with a "Phase IV" wind tunnel program to evaluate load snubbing aerodynamics. The principle purpose of this testing, conducted with an existing Boeing Vertol 1/8 scale CH-47 drag model, was to determine whether or not load snubbing causes any aerodynamic problem that would invalidate the concept, as a method for future improvement of terrain and night/IMC flight capability with containerized external cargo.

The Phase II contract statement of work required a stability assessment of snubbed MILVAN external loads. Except for hover flight conditions (discussed later), no relevant wind tunnel model test of theoretical data could be found which shed any light at all on the aerodynamic consequences of placing large bluff shaped objects (like cargo containers) in close proximity to helicopter fuselages. Because of the difficulty in predicting the complex flow patterns around such loads, rational theoretical assessment of the possible performance or stability penalties associated with snubbing was not practically attainable.

It was suspected that as a MILVAN load was brought closer and closer to the bottom of the Chinook fuselage, aerodynamic interference would create increased levels of drag and download, and might even degrade pitch and yaw stability. The happy result of the Phase IV exploratory test (conducted in the University of Maryland Wind Tunnel during February 1979) was exactly the opposite of pre-test expectations. Tunnel data (included in Reference 11 which is presented as Appendix B to this report) clearly indicated the snubbing concept to be both aerodynamically viable, and technically feasible. In fact, snubbing MILVAN and Gondola payloads on the adapter framework shown in Summary Figure 1.3, improves overall performance and stability levels, when compared to conventional container load suspension systems employing the CLAH.

Testing was organized into three separate tasks; each with different goals. Major test objectives are summarized below.

OBJECTIVES

TASK 1 - Generalized Load Snubbing Evaluation

- With a MILVAN mounted at 4 heights beneath the aircraft (from 10 feet - full scale - away, to installation on the fuselage bottom), conduct pitch and yaw runs to evaluate force and moment characteristics of the load/airframe combination

- α - Drag, Lift, Pitching Moment
- β - Yawing Moment

- Determine if snubbing causes aerodynamic problems.

TASK 2 - Snubbing Adapter/MILVAN Load Assessment

- Conduct pitch and yaw runs to evaluate adapter/load aerodynamic characteristics for the baseline Phase II/III design.
- Perform an aerodynamic cleanup of the device if practical.

TASK 3 - Determination of Aerodynamic Characteristics of the Gondola Prototype Container Configuration

- on simulated inverted "Vee" sling suspensions
- on the snubbing adapter
- with and without internal loading of F.A.R.R.P. equipment.

Using the Boeing supplied container, adapter, and strut suspension model components shown in Figure 5.1, virtually all pre-test objectives were either met, or exceeded. Seventy test runs were conducted during the one week program, which included 44 hours of tunnel occupancy. A summary of test results for each task area is presented next, starting with a brief description of preliminary tunnel and baseline testing with the bare airframe.

Baseline Results (Fuselage Only)

Prior to initiating the Generalized Evaluation, runs were made with no model in the tunnel test section, to assess the ambient pressure signature along the tunnel roof (as described in detail in Appendix B, Sections 4 and 5). Following these runs, baseline data with the model mounted in the inverted position on a reduced height strut, was then acquired. Figures 5.2 through 5.5 summarize force and moment coefficient data for the basic CH-47 airframe (which included the fuselage and pylons, landing gear, and fuel pod strakes - no spoilers, rotor hubs, or ramp strakes were installed).

Drag, lift, and pitching moment data were taken during pitch runs, made between 20° nose down, and 20° nose up angles of attack. Yawing moment results were acquired during yaw sweeps to 90° (where possible), in both directions, with the model pitch angle set at 10° nose down. Prior to the test,

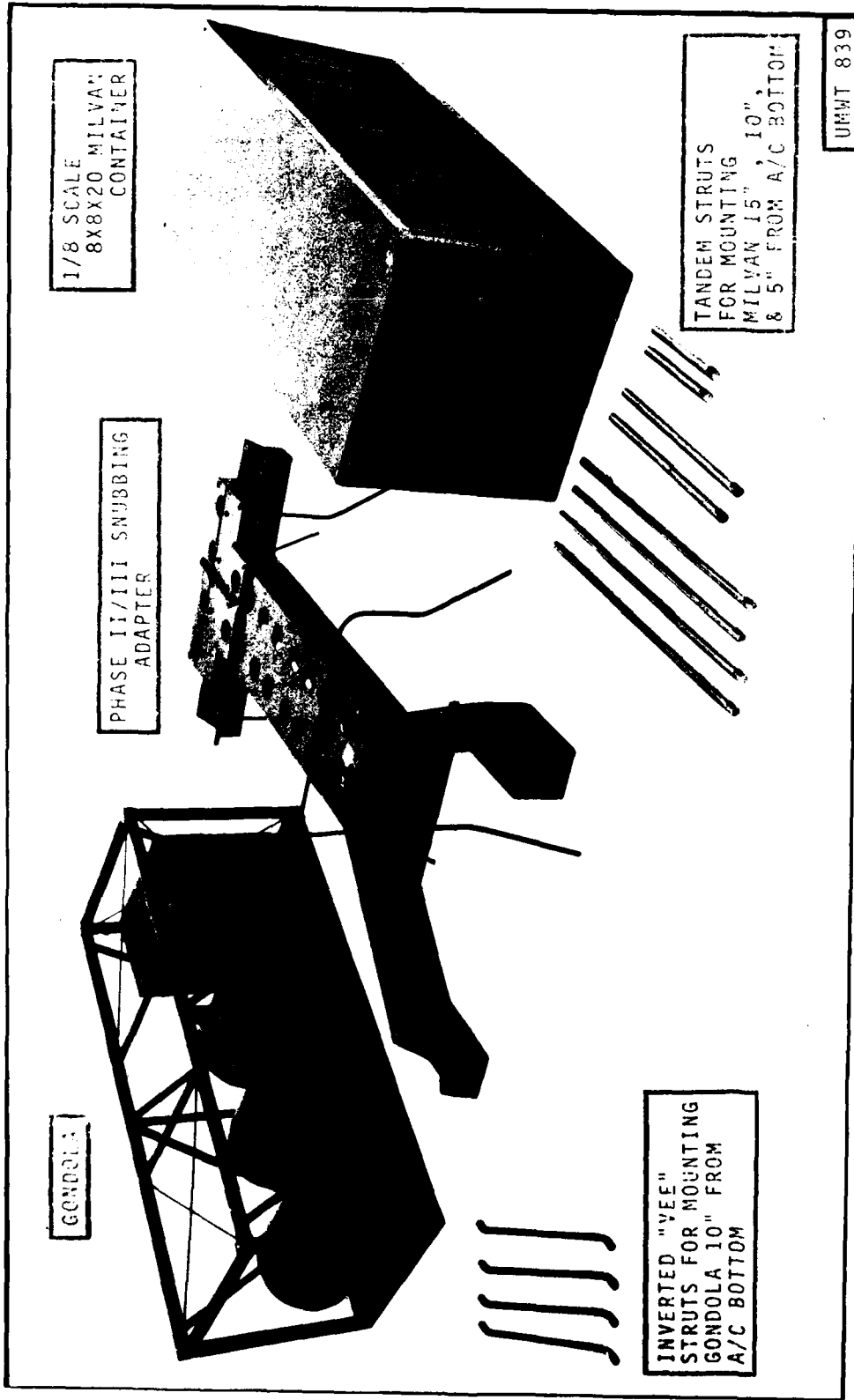

Figure 5.1 Snubbed Load Wind Tunnel Test Equipment

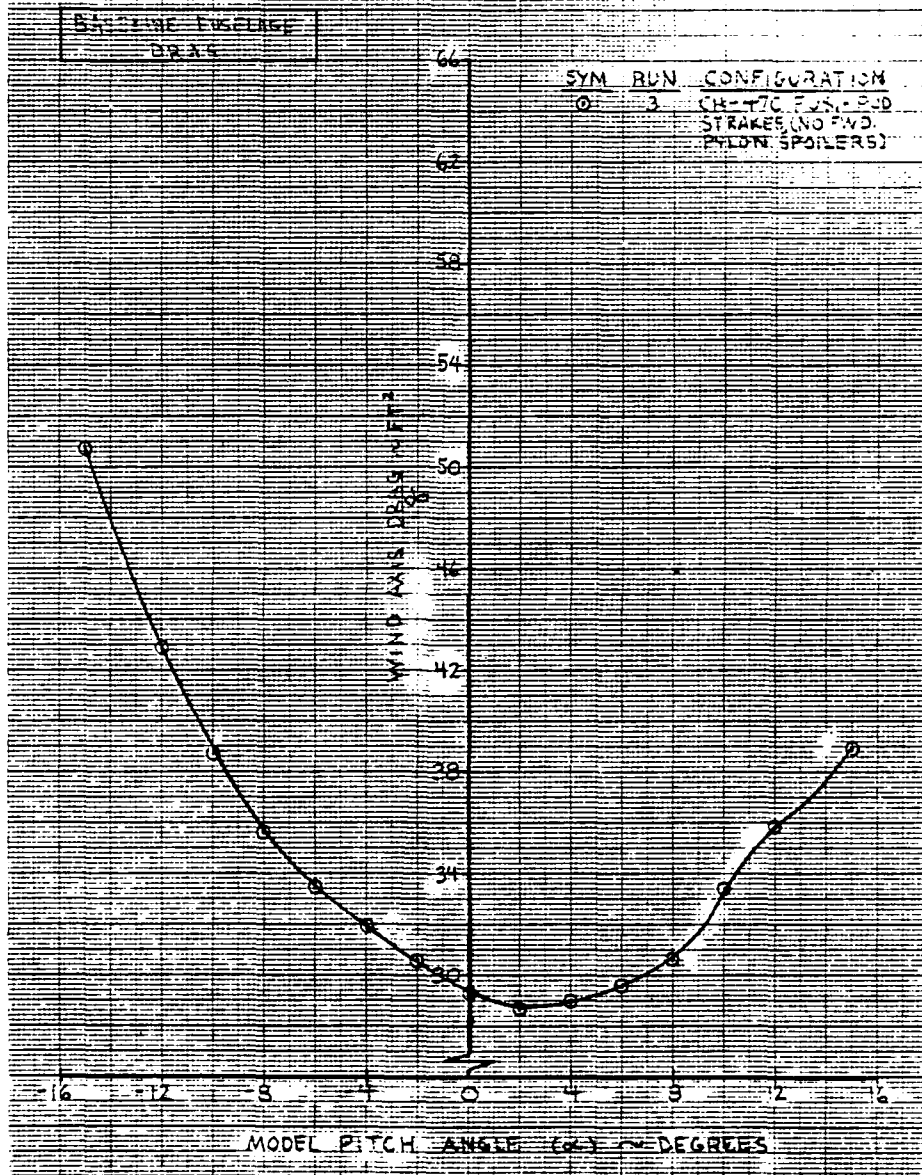

Figure 5.2 Baseline Fuselage Drag

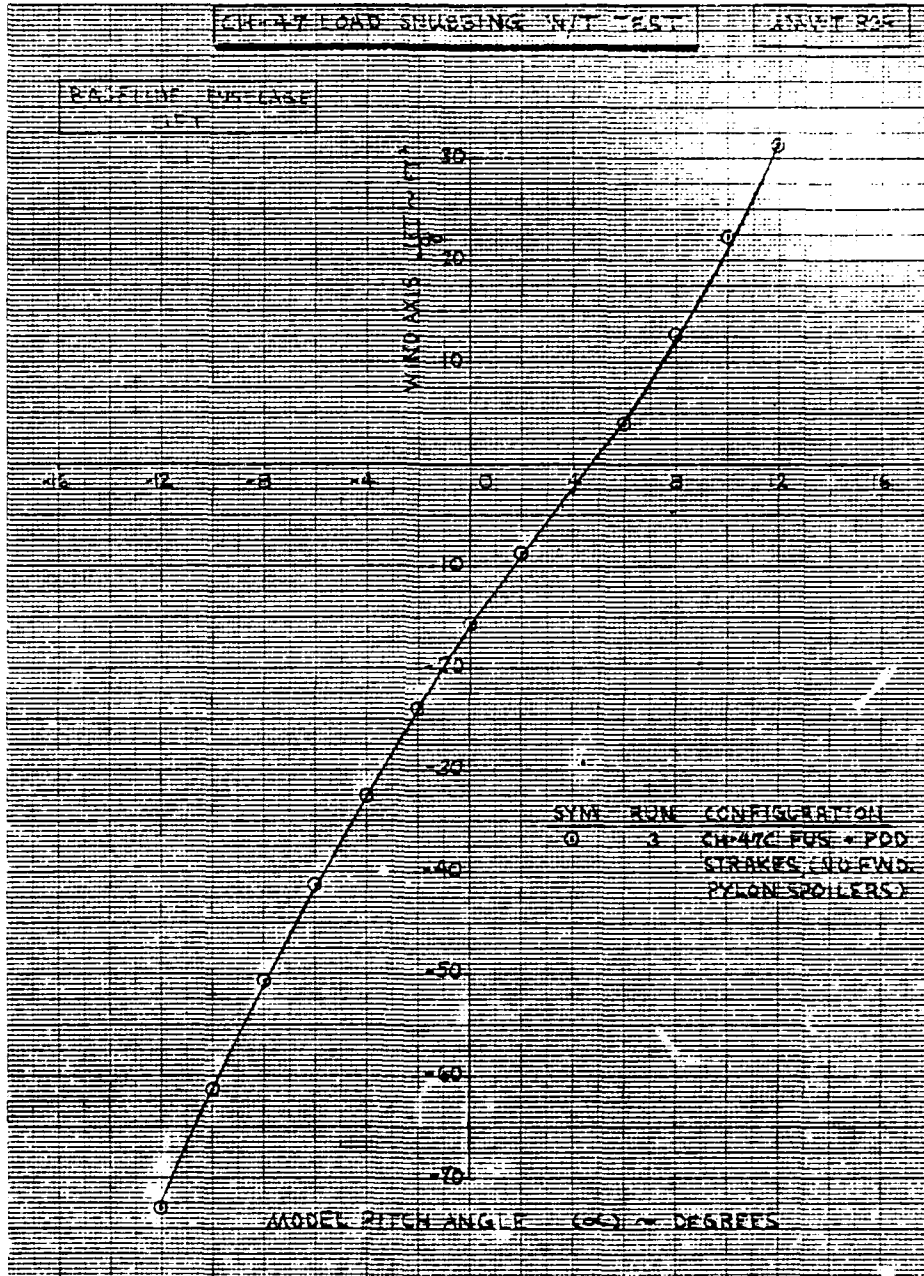

Figure 5.3 Baseline Fuselage Lift

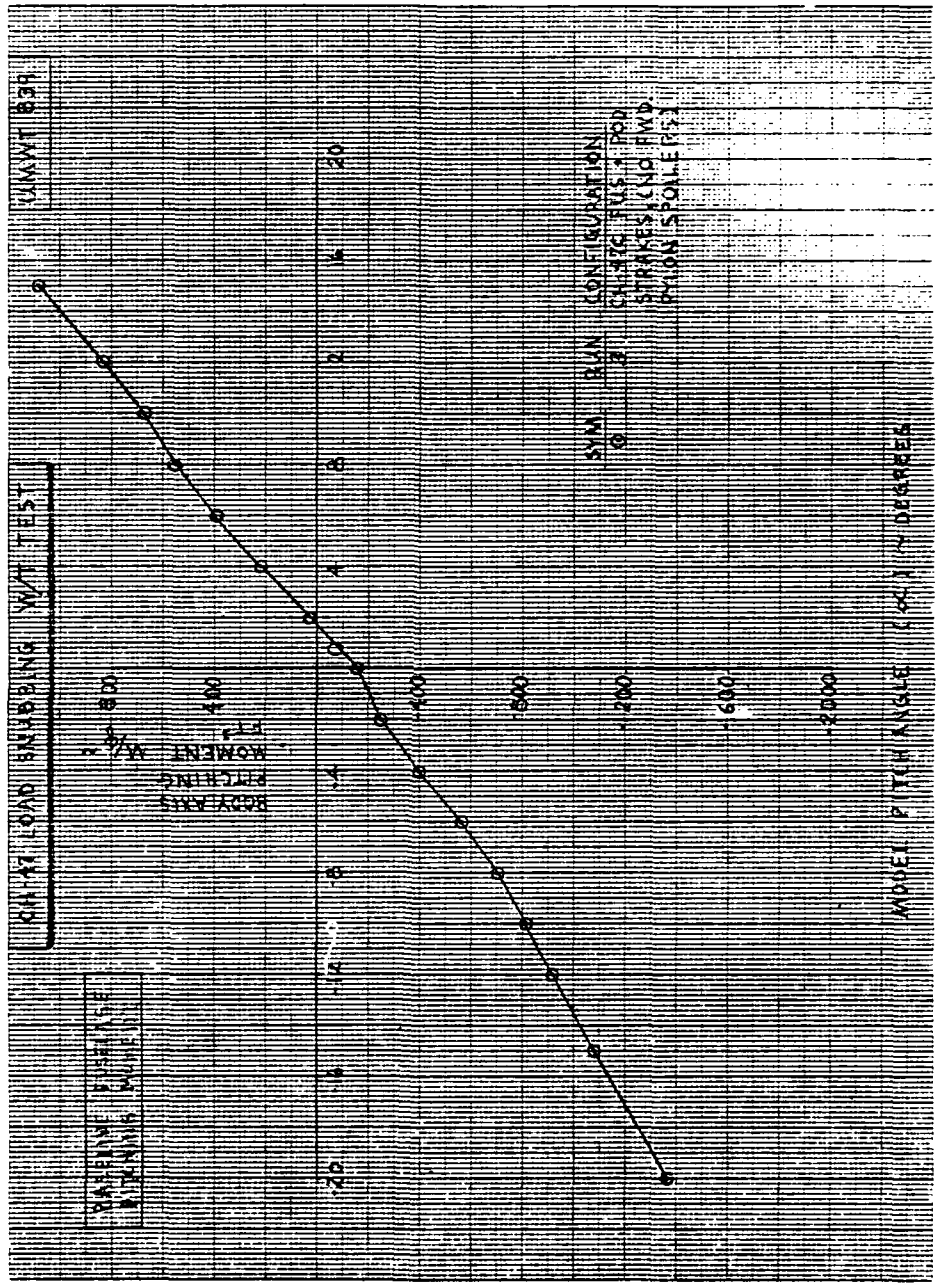

Figure 5.4 Baseline Fuselage Pitching Moment

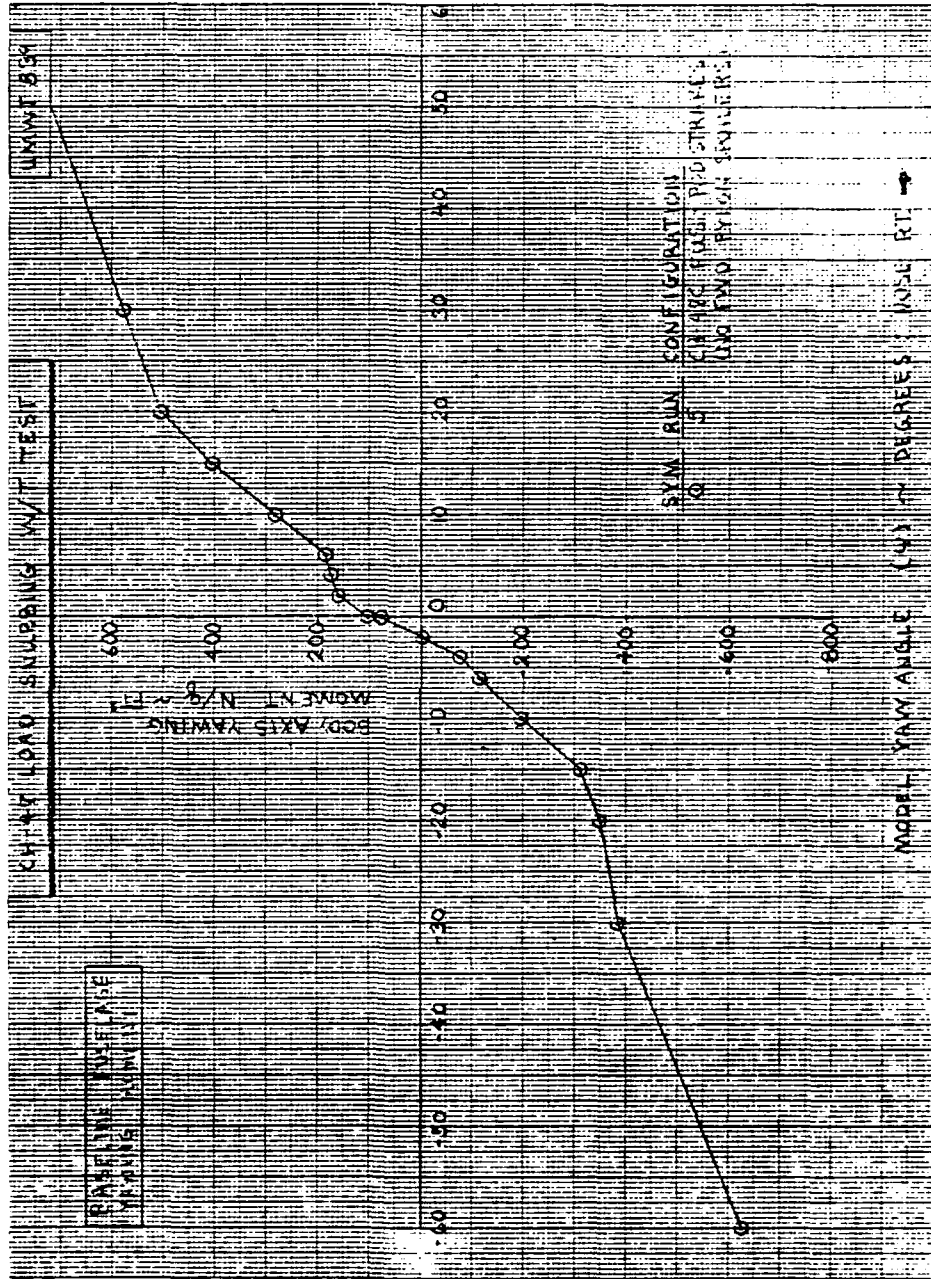

Figure 5.5 Baseline Fuselage Yawing Moment

-10° was computed to be most representative for fuselage α in the terrain flying cruise flight region. Test results confirmed initial predictions.

Base fuselage results shown in Figures 5.2 through 5.5 (and also listed in the Appendix B tabular data summary), may be subtracted from runs made with adapter mounted or strut mounted loads, to derive characteristics of the load itself (as shown in Figures 1.5, 1.7 and 1.9 in the Summary). Deriving load only, or load plus support only data is accomplished by performing the simple subtraction of data taken at the same α and z as indicated below:

$$\begin{aligned} & \text{(Fuselage + MILVAN + Mounting Struts)} \\ (-) & \text{ Fuselage Only Results} \\ = & \text{ MILVAN + Mounting Strut Data} \\ & \text{OR USING TARE RUNS MADE WITH THE FUSELAGE} \\ & \text{AND LOAD STRUT SUPPORTS ONLY (DISCUSSED LATER)} \\ & \text{(Fuselage + MILVAN + Mounting Struts)} \\ (-) & \text{ Fuselage + Struts} \\ = & \text{ MILVAN Load Only Data} \end{aligned}$$

Utilizing the baseline fuselage, or fuselage plus strut tare data given in Appendix B, virtually any desired test comparison of load aerodynamics can be made. This point is brought out in the "Generalized" Load Snubbing Evaluation results described next.

5.1 GENERALIZED LOAD SNUBBING EVALUATION

Figures 5.6 and 5.7 illustrate the test setup for the generalized evaluation. During this testing, the MILVAN was mounted with its top located 15", 10", 5", and 0" from the fuselage lower skin, to determine approximately where aerodynamic interaction between the load and fuselage started. Results are shown in Figures 5.8, 5.9, 5.10 and 5.11. These plots clearly show that moving the load closer to the airframe reduces drag and fuselage-plus-load negative lift (called download) in the negative angle of attack range of interest, where the Chinook will cruise with an externally mounted container. Pitching moment slope (M_α), reflecting the level of static pitch stability, is essentially unchanged with load height, although the magnitude of the absolute nose down pitching moment (due to the load) increases, as expected, at the larger load distances.

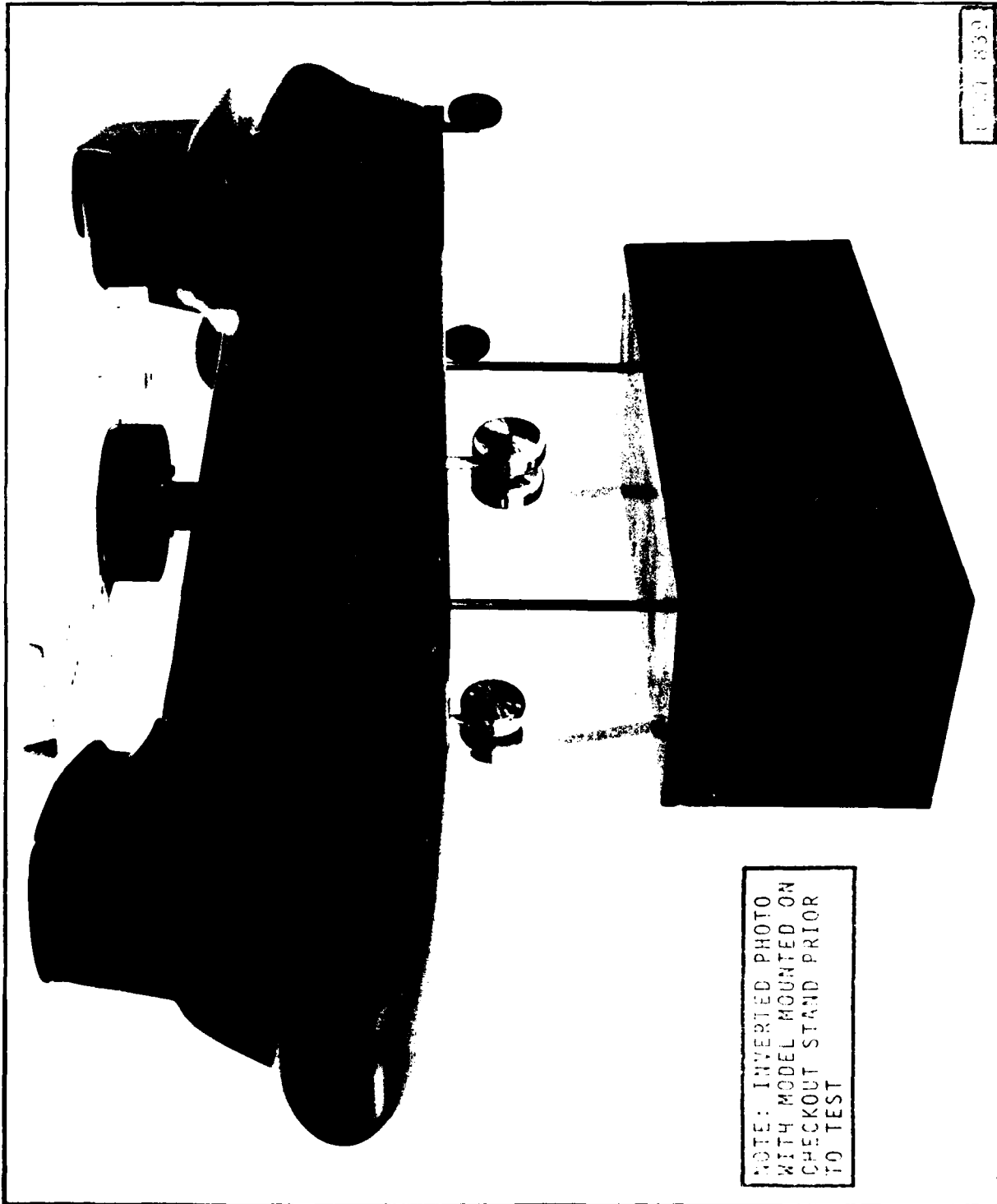
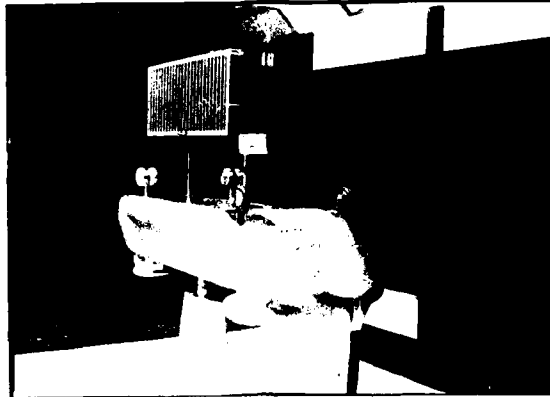
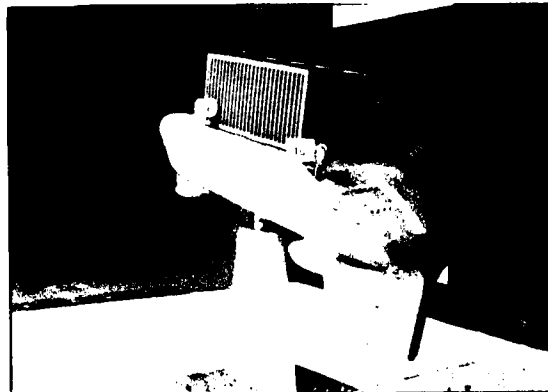

Figure 5.6 CH-47 Model 1 Configured with MILVAN for "Generalized" Load Snubbing Evaluation



MILVAN ON 10 INCH (6.67 FT. FULL SCALE) STRUTS

*Note Installation of Tuft Grids Mounted of Fuselage Bottom, Ramp & Aft Pylon, & Tuft Wands Extending from MILVAN & Ramp Apex



MILVAN FULLY SNUBBED TO FUSELAGE BOTTOM

Note Tape Covering Pressure Ports on A/C Ramp ζ

Figure 5.7 "Generalized" Load Snubbing Evaluation with MILVAN

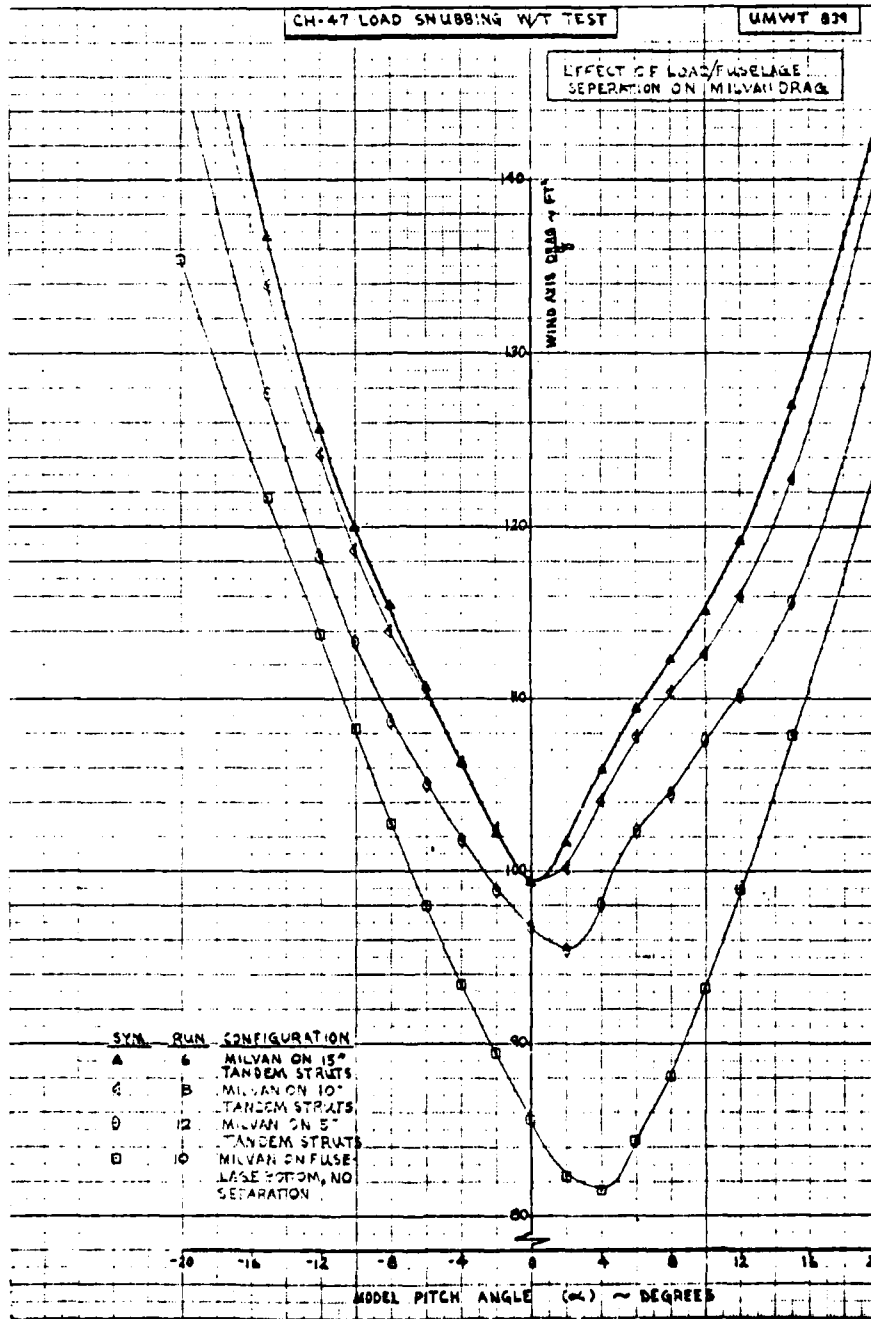

Figure 5.8 Effect of Load/Fuselage Separation on MILVAN Drag

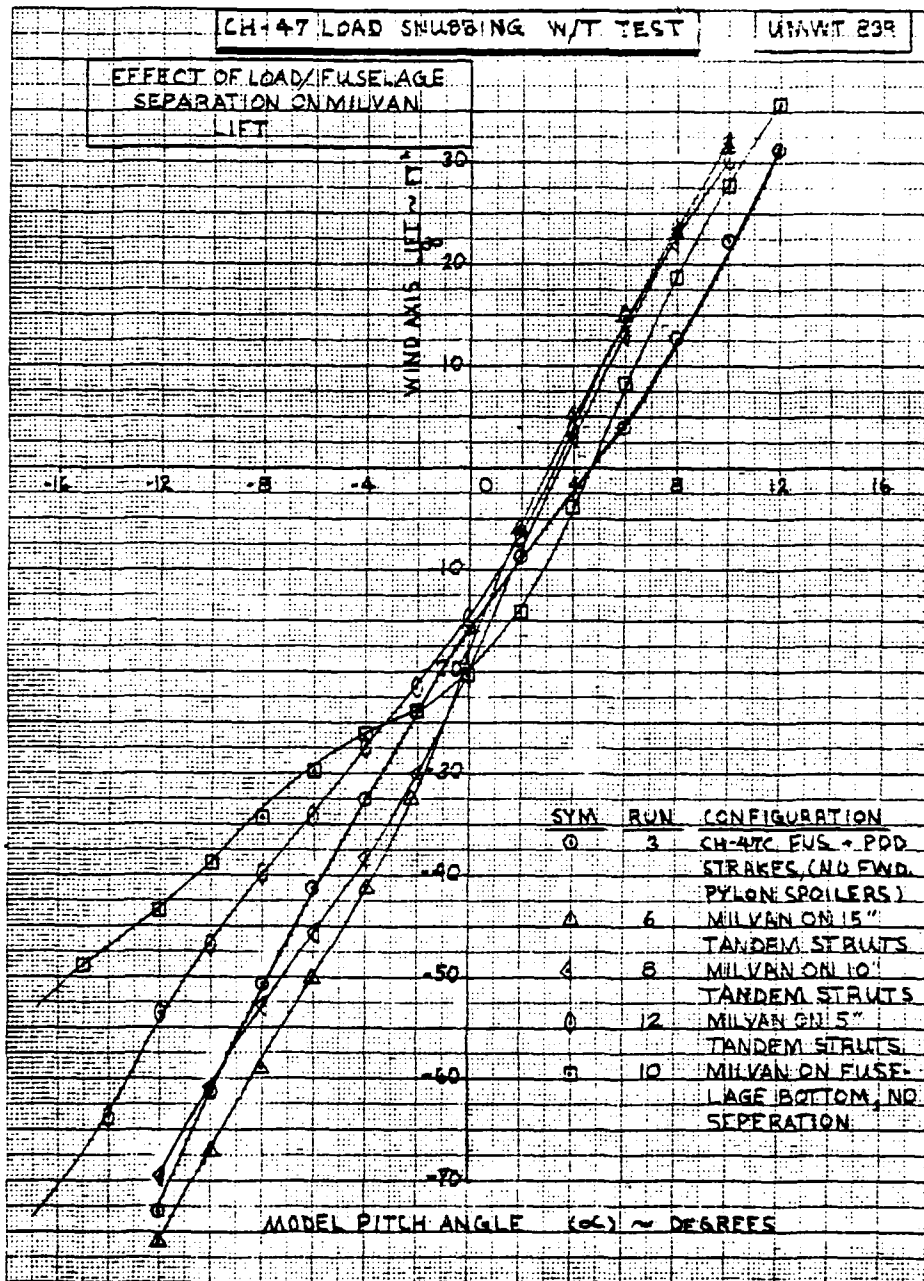

Figure 5.9 Effect of Load/Fuselage Separation on MILVAN Lift

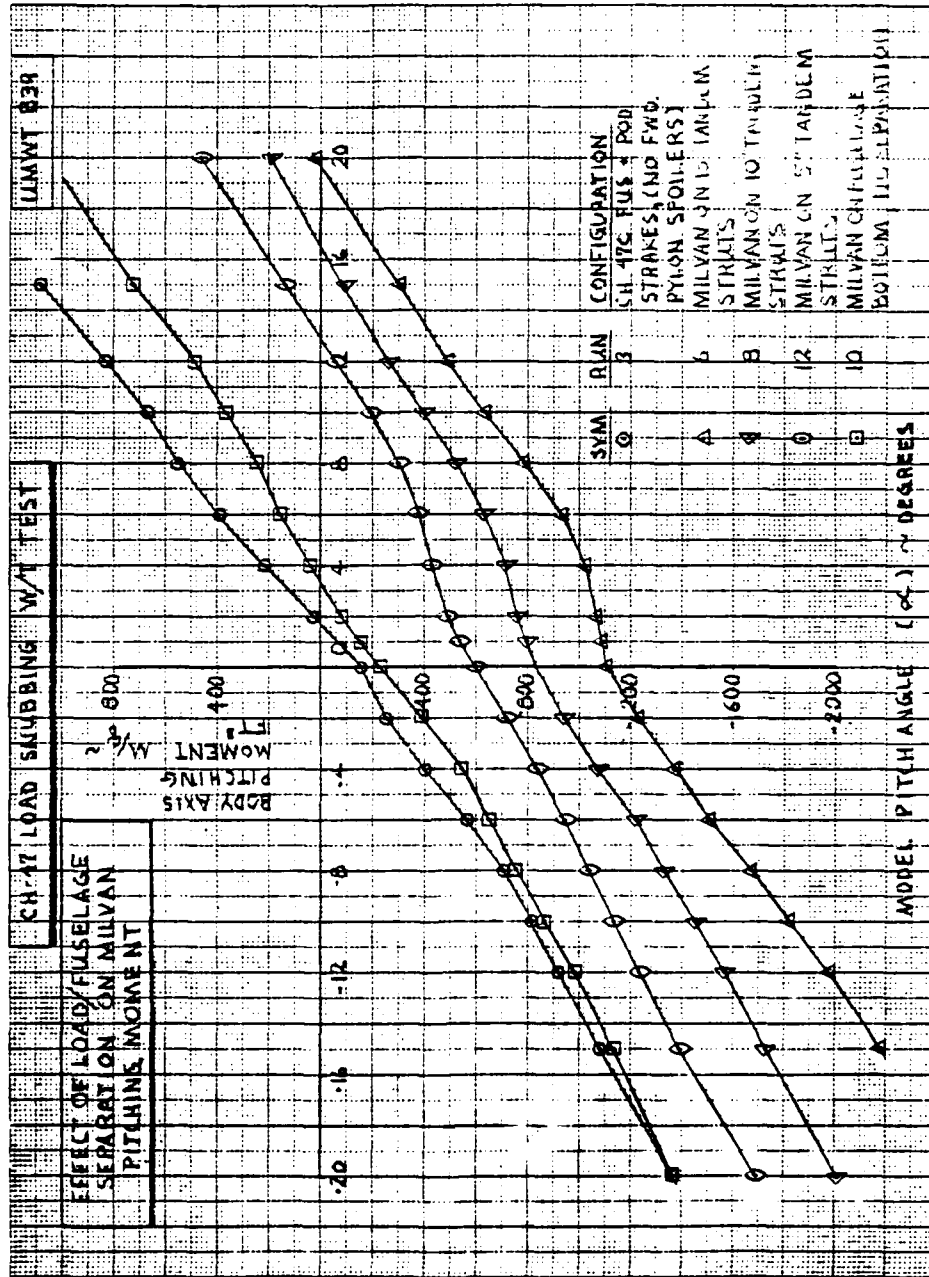

Figure 5.10 Effect of Load/Fuselage Separation on MILVAN Pitching Moment

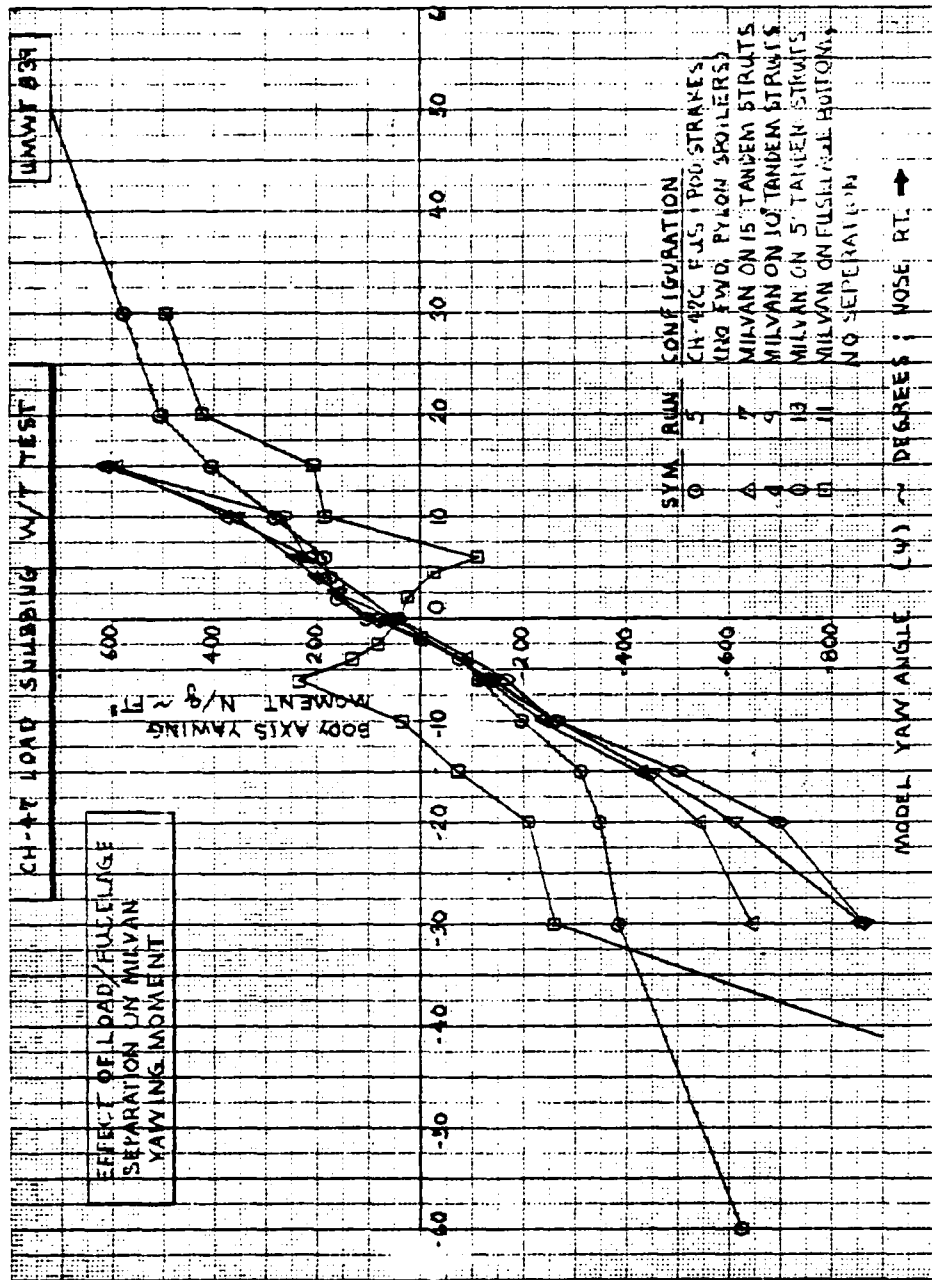

Figure 5.11 Effect of Load/Fuselage Separation on Yawing Moment

It should be pointed out that Figures 5.8 through 5.11 reflect the characteristics of the fuselage and the load and the mounting struts, as described earlier. Load only aerodynamic characteristics can be evaluated by subtracting out the fuselage plus strut tare run results plotted in Figures 5.12 through 5.15, for the various length struts.

The test results for the "Generalized" snubbing evaluation were at first thought puzzling, since increased drag and download or possibly reduced stability levels were expected to go hand and hand with snubbing.

What actually occurred was a favorable modification of airflow around the aircraft ramp; which, in effect, "decambered" the fuselage and substantially lowered its induced drag, as the load was brought closer and closer to the aircraft lower surface. Concurrent with improved drag and lift characteristics, was an improvement in static directional stability (N_{β}) at low yaw angles (Figure 5.11) and the neutral pitch stability (M_{α}) contribution of the load described earlier. These stability characteristics are significant, since no modification to the aircraft AFCS is required when carrying loads in the snubbed configuration.

5.2 SNUBBING ADAPTER AERODYNAMIC CLEANUP AND PERFORMANCE ASSESSMENT

Figure 5.16 presents a photo of the initial Phase II/III Adapter Configuration at the start of testing, and Figure 5.17 illustrates two improved versions of the device, photographed in the middle, and at the end of the program. Both "cleaned-up" adapter configurations had almost identical aerodynamic characteristics in the nose down cruise α range, as will be described later. The simple structural change from the initial Phase II/III configuration (shown at the bottom of Figure 5.17) was selected as the "Final" adapter for the snubbing program.

Figures 5.18, 5.19, 5.20, and 5.21 compare aerodynamic coefficient data for the original adapter, and for the two cleaned up configurations developed during the test. In the drag plot 5.18, all three MILVAN/adapter combinations are compared with a MILVAN mounted on struts simulating a 10 foot level sling suspension. In Figure 1.7 in the report Summary (comparable to Figure 5.18 here), the drag penalty of the original adapter is shown to be 20 ft² greater than that finally achieved, after completion of the cleanup program described next.

COMPARISON OF MILVAN
TANDEM STRUT TARE
DRAG

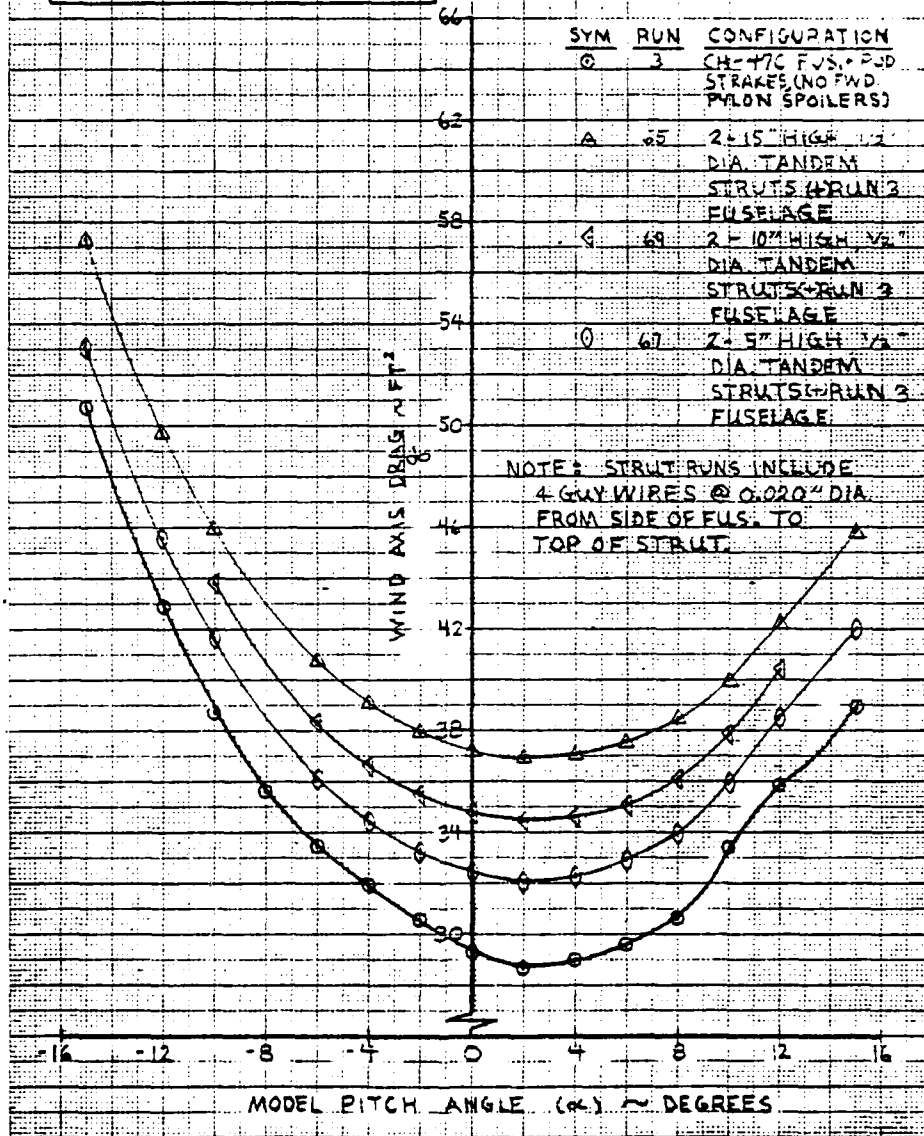

Figure 5.12 Comparison of MILVAN Tandem Strut Tare Drag

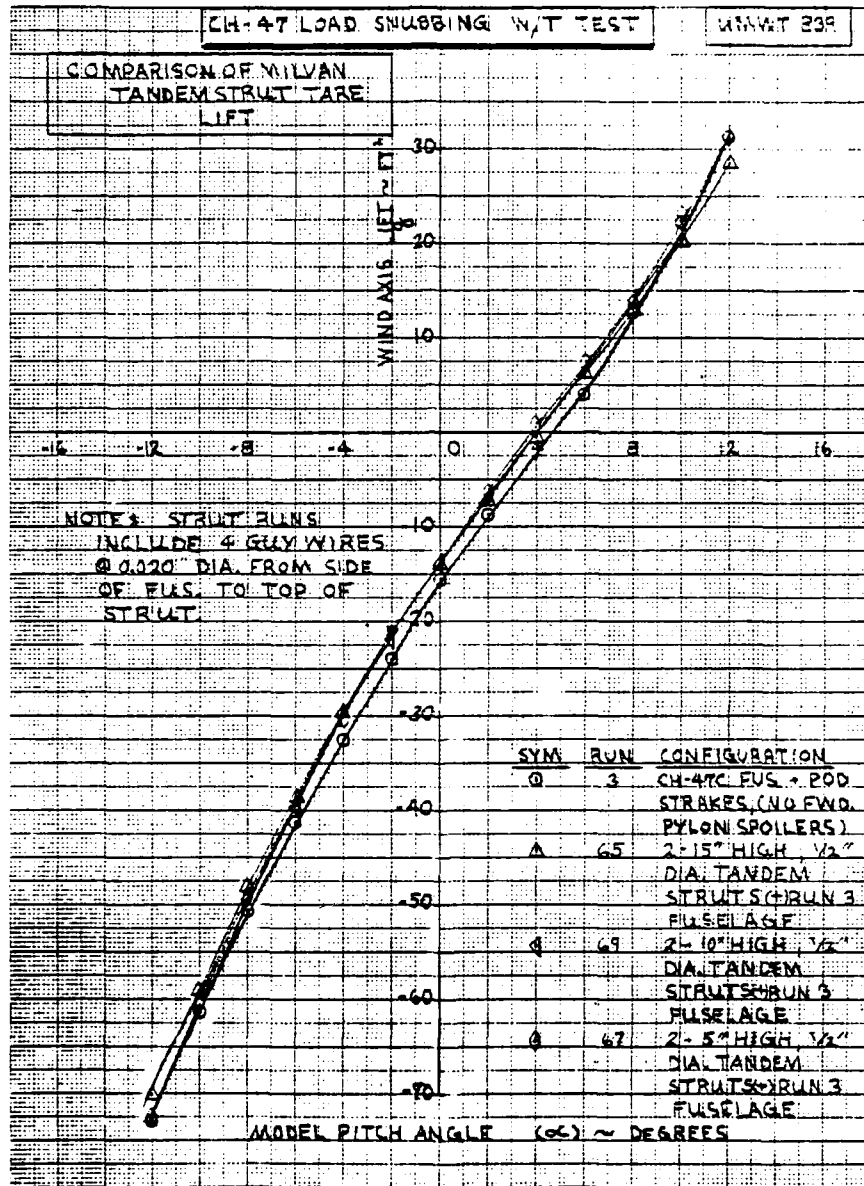

Figure 5.13 Comparison of MILVAN Tandem Strut Tare Lift

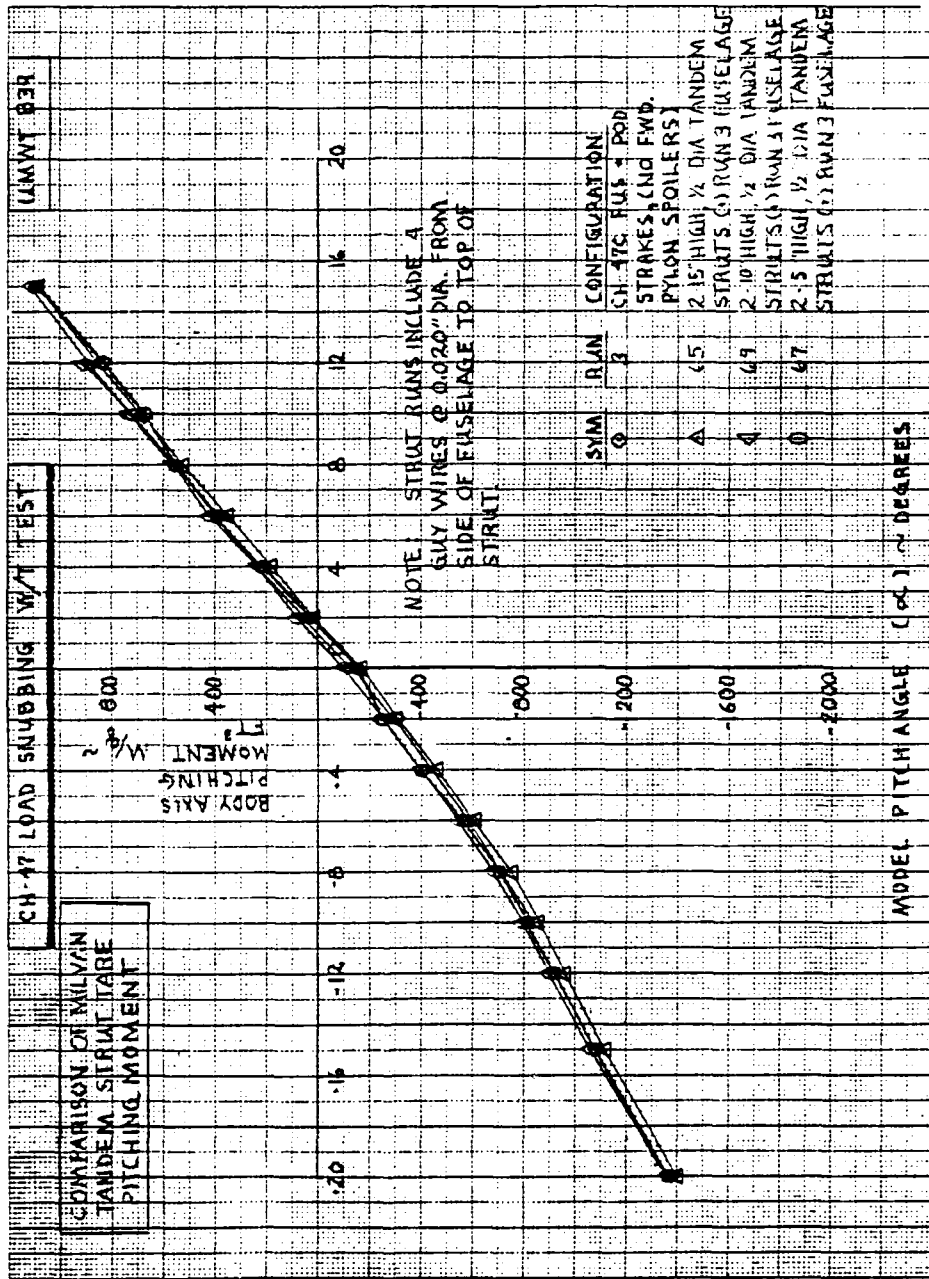

Figure 5.14 Comparison of MILVAN Tandem Strut Tare Pitching Moment

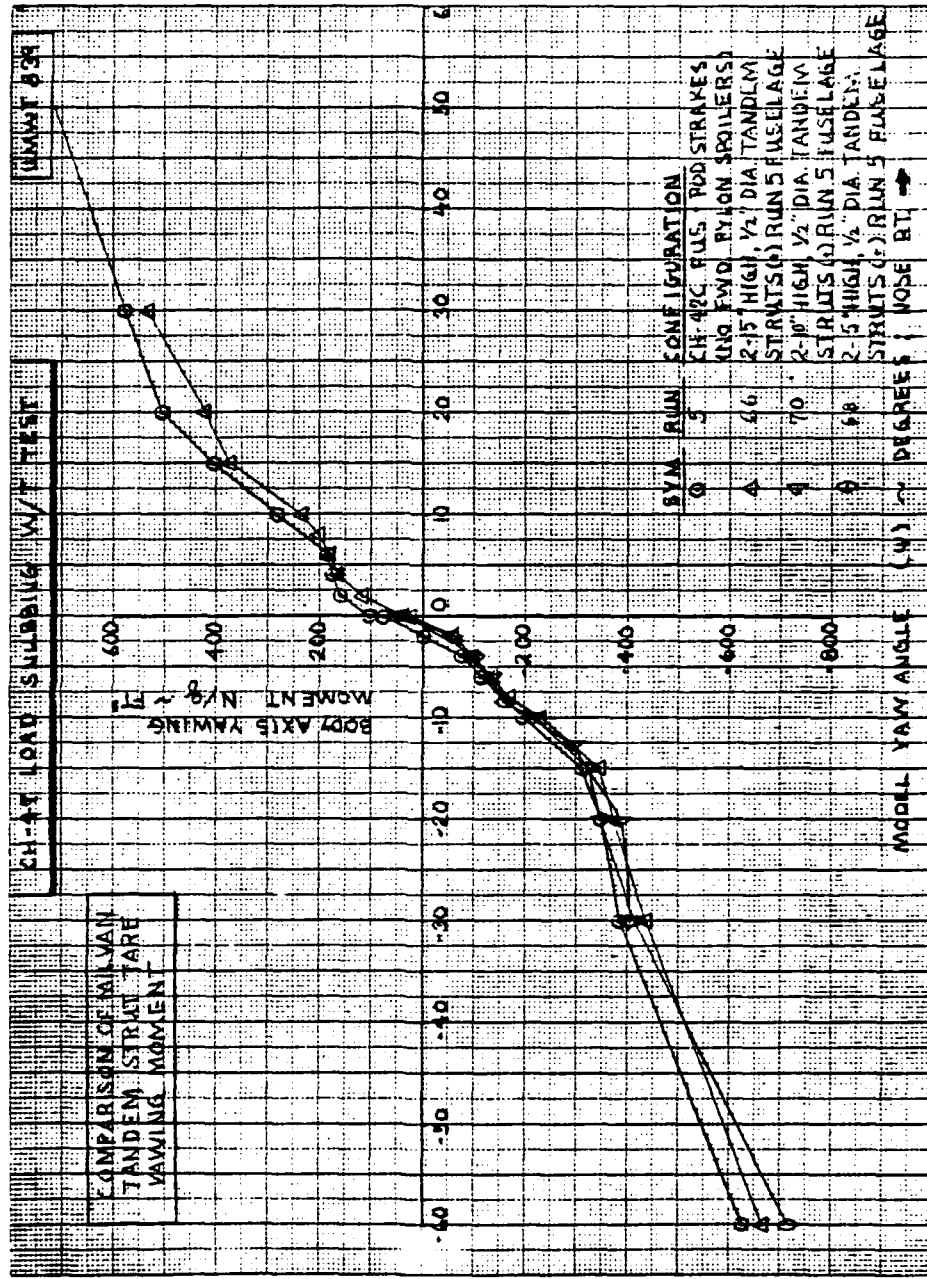
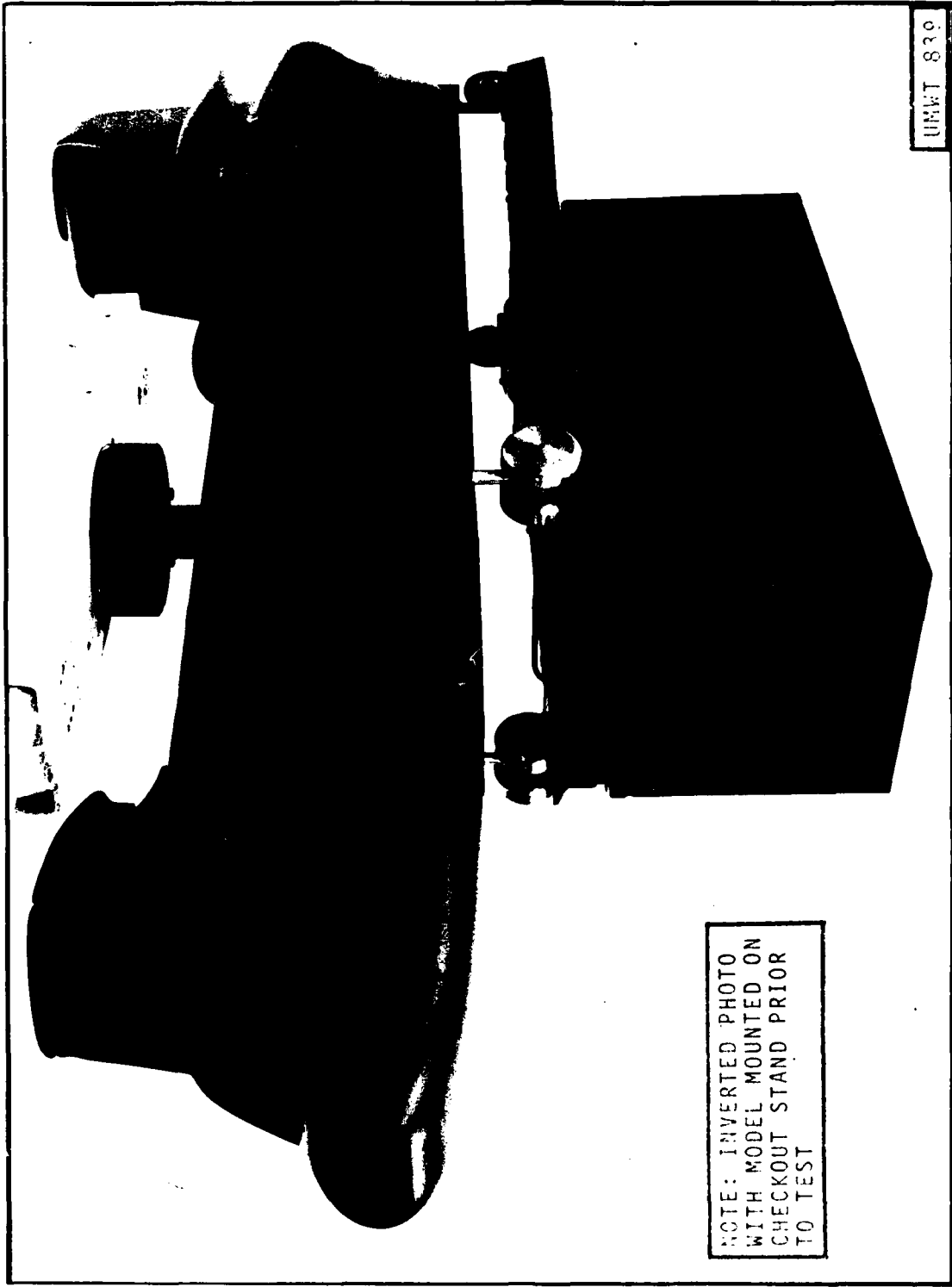

Figure 5.15 Comparison of MILVAN Tandem Strut Tare Yawing Moment



UMWT 839

NOTE: INVERTED PHOTO
WITH MODEL MOUNTED ON
CHECKOUT STAND PRIOR
TO TEST

Figure 5.16 CH-47 Model Configured with Initial Phase II/III Snubbing Adaptor at Start of Aerodynamic Cleanup Testing

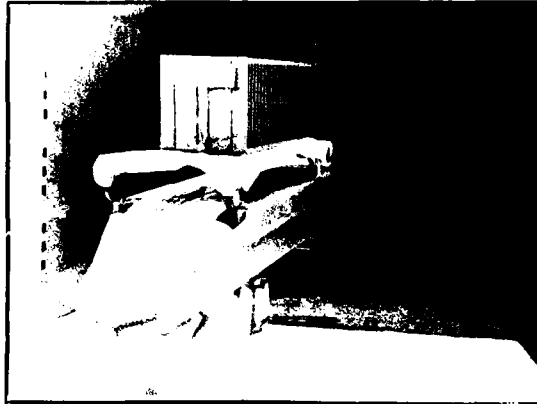

STREAMLINE CONFIGURATION WITH FAIRINGS ON
LANDING GEAR EXTENSION ARMS (RUN 37/38)

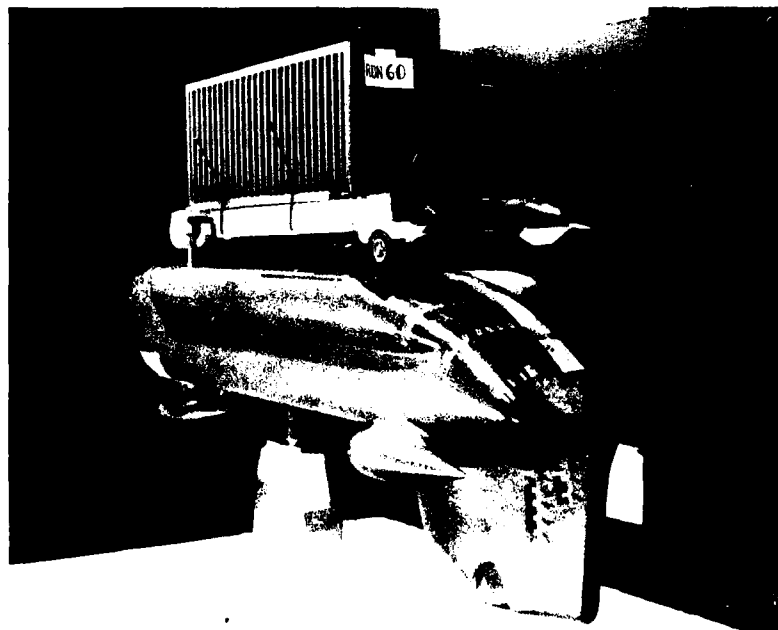

FINAL ADAPTER CONFIGURATION, BEFORE REMOVING TAIL WEDGE
FAIRING & INSTALLING AFT GEAR ARM TAPER (RUN 59/60)

*Note: With Wedge Removed & Arms Tapered (Run 62/63) Aero
Characteristics were Same As (59/60) & Slightly Better Than
(37/38)

Figure 5.17 Cleaned Up Snubbing Adapter & MILVAN Load

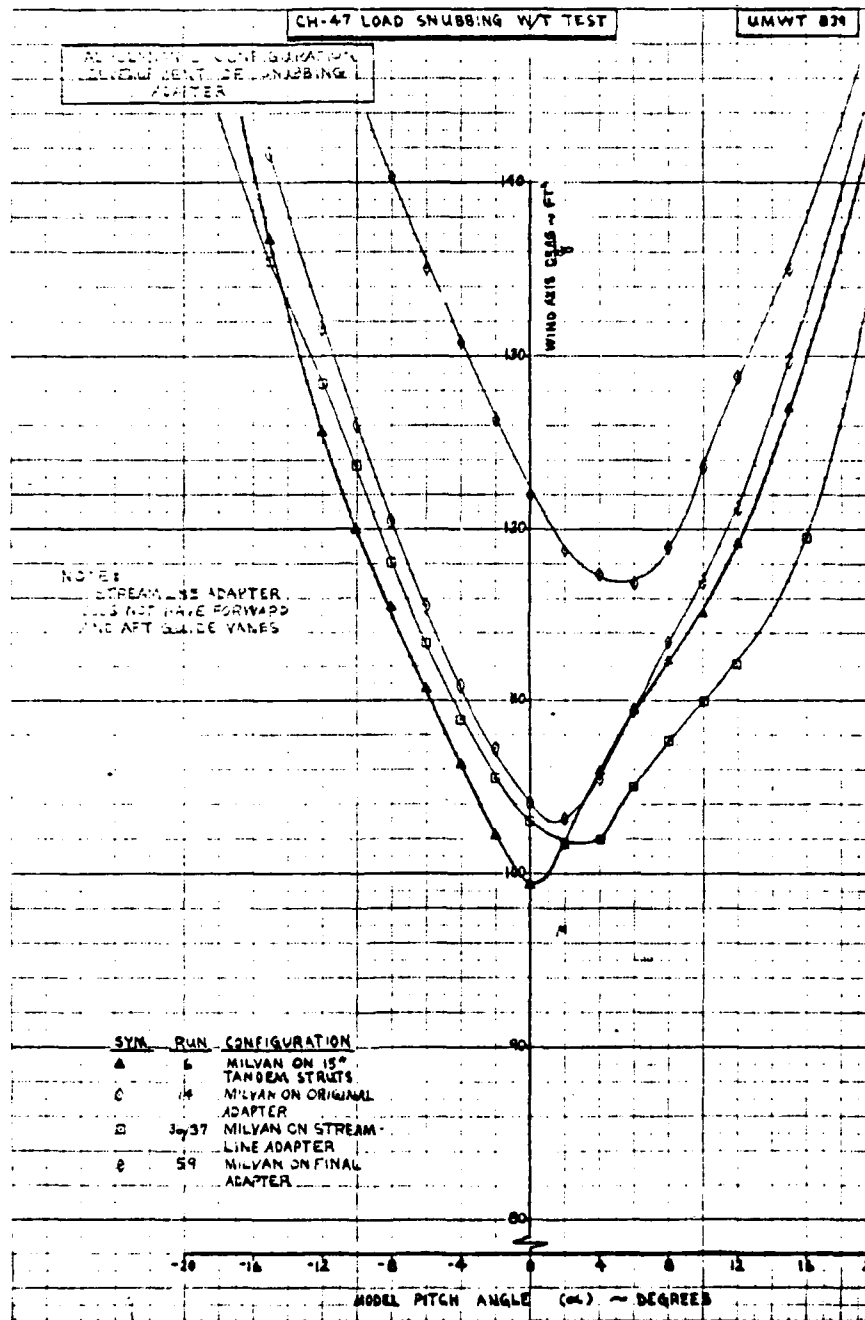

Figure 5.18 Aerodynamic Configuration Development of Snubbing Adapter - Drag

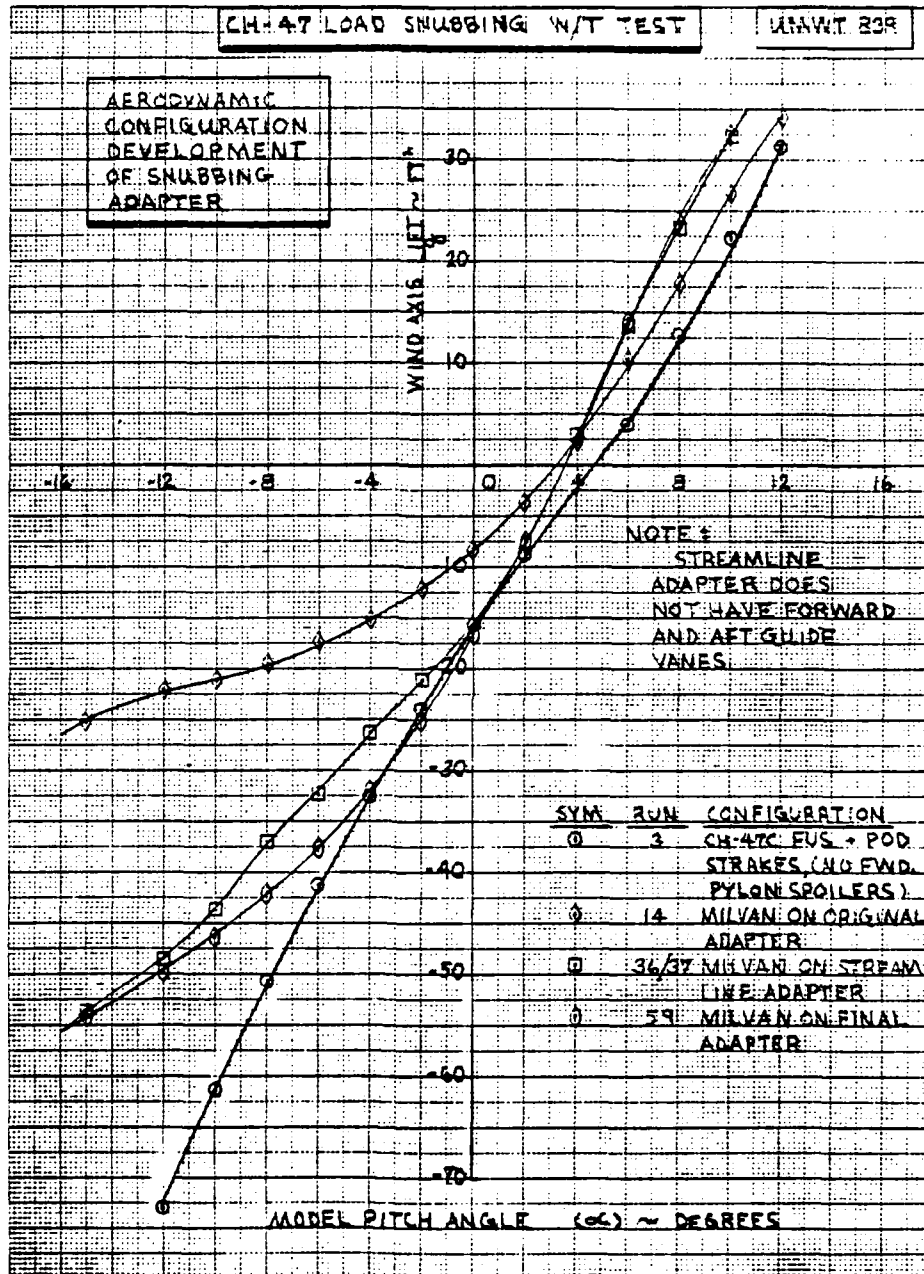

Figure 5.19 Aerodynamic Configuration Development of Snubbing Adapter - Lift

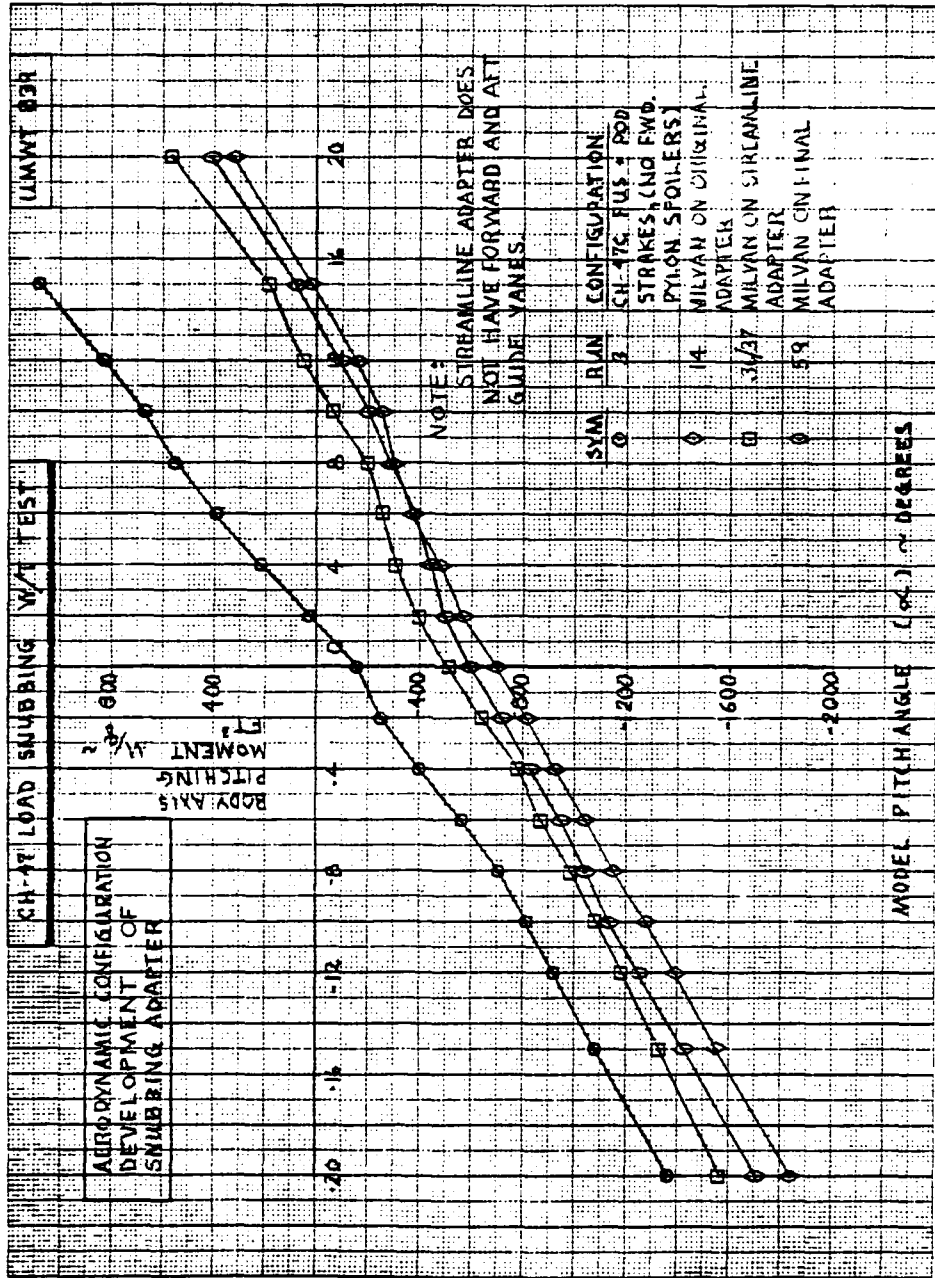

Figure 5.20 Aerodynamic Configuration Development of Snubbing Adapter - Pitching Moment

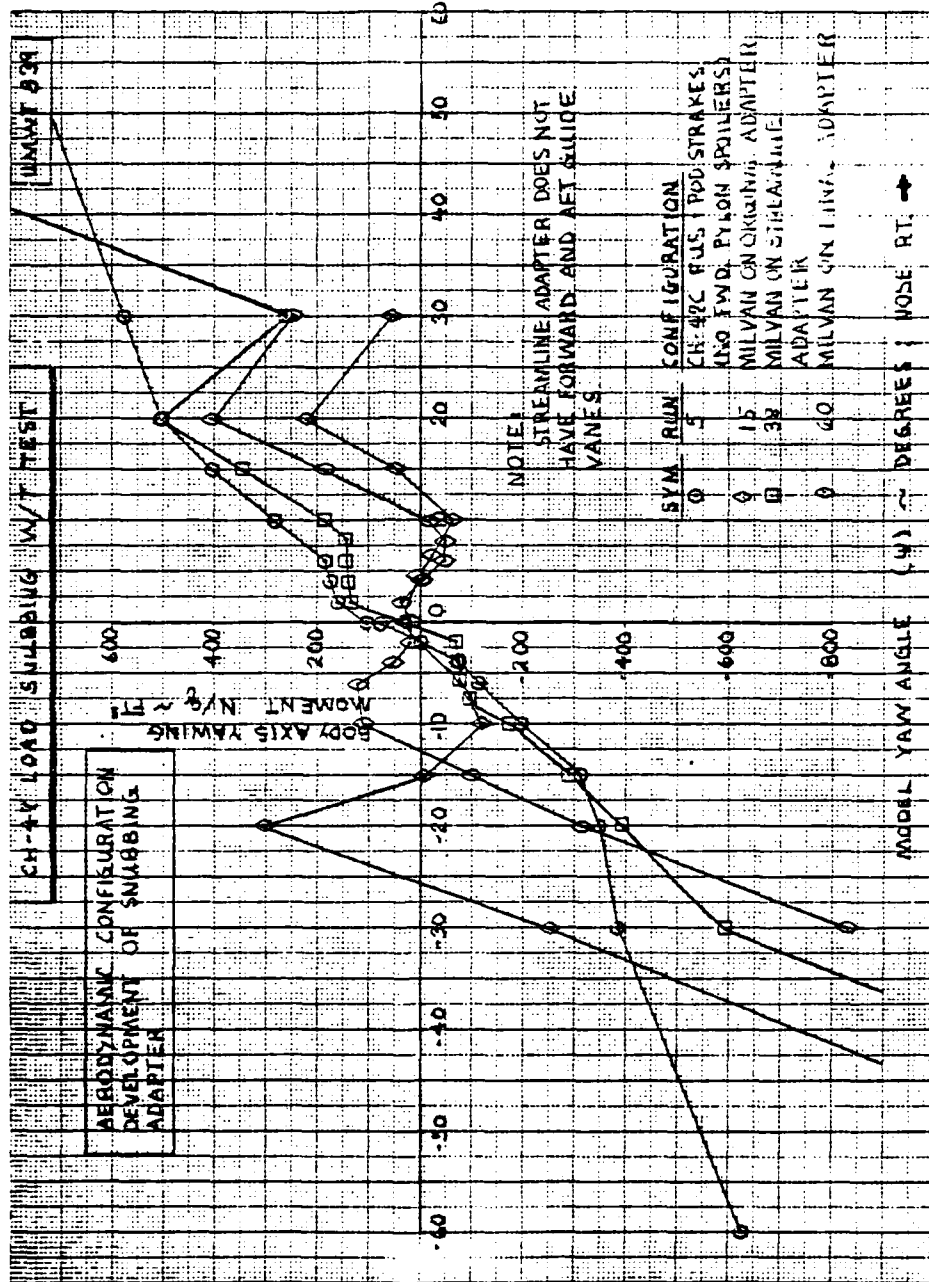

Figure 5.21 Aerodynamic Configuration Development of Snubbing Adapter - Yawing Moment

Adapter Cleanup

Based on the MILVAN runs made during the "Generalized" test (Figures 5.8 & 5.9) it was expected that mounting the MILVAN load on an adapter (several feet beneath the fuselage) would not incur large drag or download penalties. As shown in both Figures 5.18 and 1.7, the drag penalty of the first adapter was enormous - more the 30 ft² greater than at the comparable MILVAN height from "Generalized" results.

Initial attempts to reduce separation through the use of "flow-director" vanes and plates mounted in front of, and behind the adapter, were totally ineffective in reducing the unacceptable drag penalty, or areas of extremely rough flow between the adapter and the fuselage. The fuselage/load combination was so badly separated (as seen in tuft grid patterns behind the aircraft), that the aerodynamic cambering effect of the fuselage ramp became totally ineffective; with the result that download was reduced appreciably.

Unfortunately, the very high drag levels, and certain increase in fuselage vibratory loads caused by the separation produced by this configuration, made these very attractive download characteristics virtually unusable. Nevertheless, as shown in Figure 5.19, the cleaned up adapter configuration as finally developed, exhibited download characteristics (in the negative α range), better than those of the bare fuselage. This characteristic of reduced negative lift results in a performance improvement, as will be shown later. In addition to improved download, the snubbed MILVAN also exhibits a substantially improved directional stability (N_{δ}) contribution, at yaw angles between $\pm 10^\circ$; when compared to the bare fuselage (35 ft³/degree).

After finding that flow director approaches would not work, the sides of the adapter were widened out to coincide with the lateral dimension of the MILVAN. A large drag reduction and download improvement ensued, as the flow smoothed out considerably between the adapter and fuselage. Applying fairings and rounding the front of the adapter further reduced drag. A final incidence adjustment of 3° (in a nose up direction) dropped drag again by almost 15 ft². The resulting configuration, called the "Streamline" adapter, produced the aerodynamic improvements shown in Figures 5.18 through 5.21.

To determine sensitivity of each of the fairings relative to the total improvement measured (so as to achieve the simplest configuration for manufacturing purposes), it was decided to remove them one-by-one and make drag/lift pitch runs to assess the contribution of each. Removing the fairings from the aft gear extension arms (shown at the top of Figure 5.17) produced the drag increases of 3 to 4 ft² expected.

Surprisingly, when the fairings on the forward gear "teardrop" housings were removed, drag went down - a lot. What had happened was that as the incidence of the adapter was changed to reduce drag, the favorable interference contribution of the forward gear fairings had changed appreciably from initial characteristics measured earlier.

The net result of removing all streamlining was that when the fairings (except for the rounded nose) were deleted, drag and lift were essentially identical to that of the "Streamline" configuration. Thus, what was left was the original adapter with widened sides, increased positive incidence, and a slightly rounded-off forward surface - a very satisfactory result from the standpoint of redesign required to achieve an easily fabricated structure.

Figure 5.22 summarizes the incremental performance benefits of the cleanup process and shows where the major changes were made. The 20 ft² drag improvement noted on the figure increases normal power speed by 4 to 5 knots, and reduces aircraft power requirements by about 400 shaft horsepower (both of which are worthwhile when considered in the context of fleet life cycle fuel costs etc.).

Performance Assessment

Referring again to Figure 1.7 in the Summary, shown in addition to adapter performance are drag results for a MILVAN supported on level, equal length, 10 foot full scale simulated sling suspensions (just as the model was tested in the "generalized" snubbing evaluation discussed earlier). Flight test experience indicates that in order to achieve satisfactory levels of load directional stability, suspensions providing 10° nose down attitudes for the MILVAN are required.

When this nose down load increment is accounted for, and then added to the 5 to 7 ft² drag penalty associated with the CLAH adapter, the result is a drag polar somewhat above that shown for the "final" snubbed MILVAN result. In short, flying a MILVAN snubbed will have a substantially lower drag penalty, when compared to doing the job with a 10 to 20 foot conventional sling suspension and CLAH arrangement.

Figures 5.23 and 5.24 present a comparison of the cruise download contribution of snubbed and conventionally suspended MILVAN containers. The left hand plot in Figure 5.24 was derived from lift information given in Figure 5.23. It reflects a lower download with the snubbed MILVAN than is produced when payloads are carried internally, out to about 70 knots cruise speed. At 50 knots the conventional 10° nose down suspension has a download exceeding that of the snubbed configuration by over 900 pounds. At 110 knots (which is well

ADAPTER AERODYNAMIC CONFIGURATION
"CLEAN-UP"

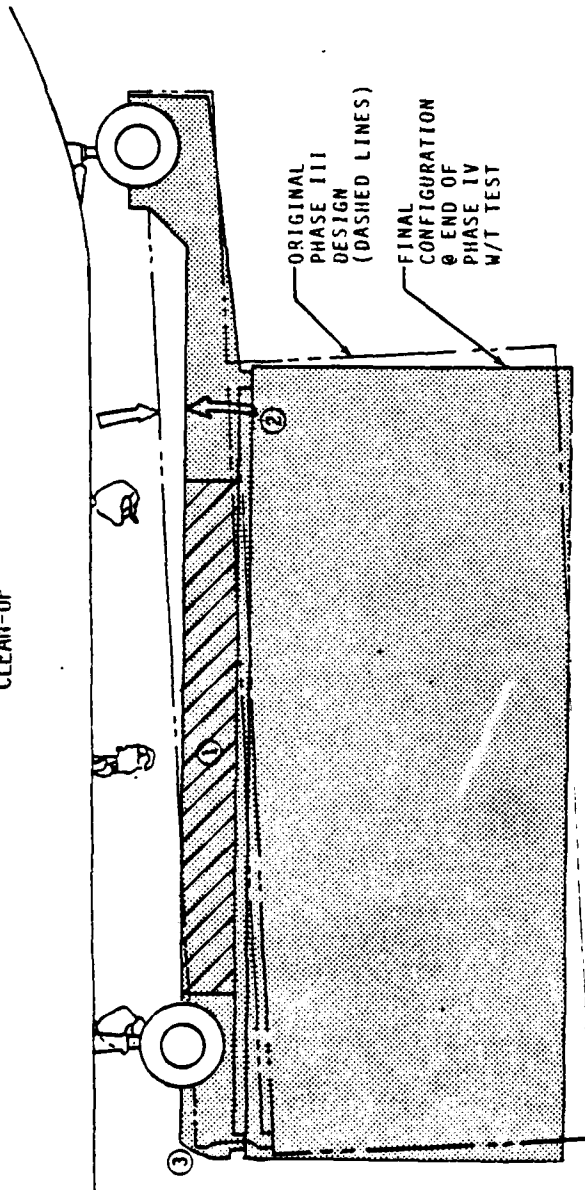

CONFIGURATION CHANGE

1. WIDEN ADAPTER TO BE FLUSH WITH MILVAN SIDES.....	5.0 FT ²
2. INCREASE ADAPTER INCIDENCE ANGLE 3° (WRT FUS) & SEAL UP ALL LIGHTENING HOLES IN ADAPTER TOP	14.5 FT ²
3. ROUND NOSE OF ADAPTER5 FT ²
TOTAL	20.0 FT ² @ $\alpha = -10^\circ$

DRAG REDUCTION INCREMENT

.....	5.0 FT ²
.....	14.5 FT ²
.....	.5 FT ²

Figure 5.22 Adapter Aerodynamic Configuration - "Clean-up"

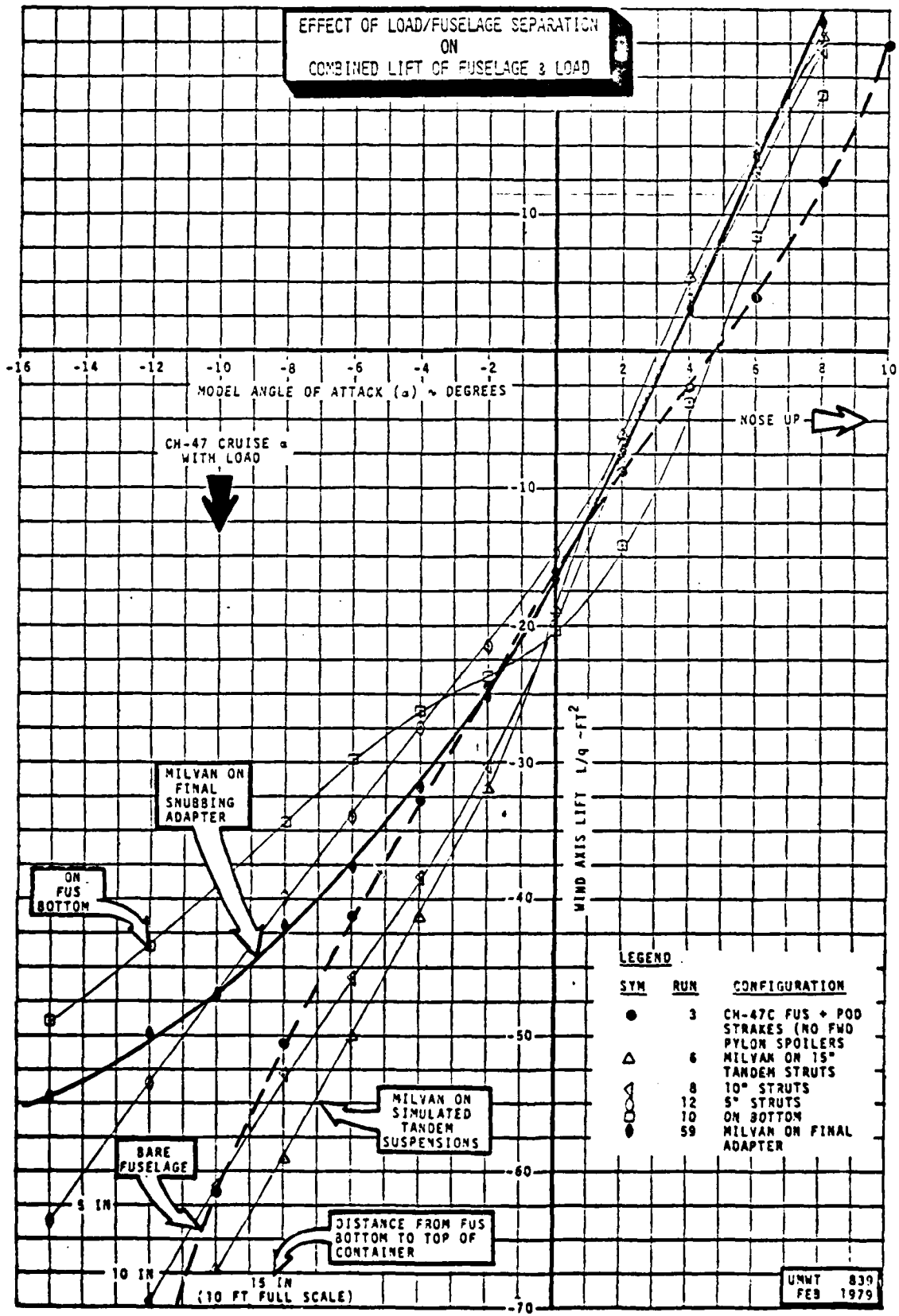

Figure 5.23 Effect of Load Snubbing on Lift

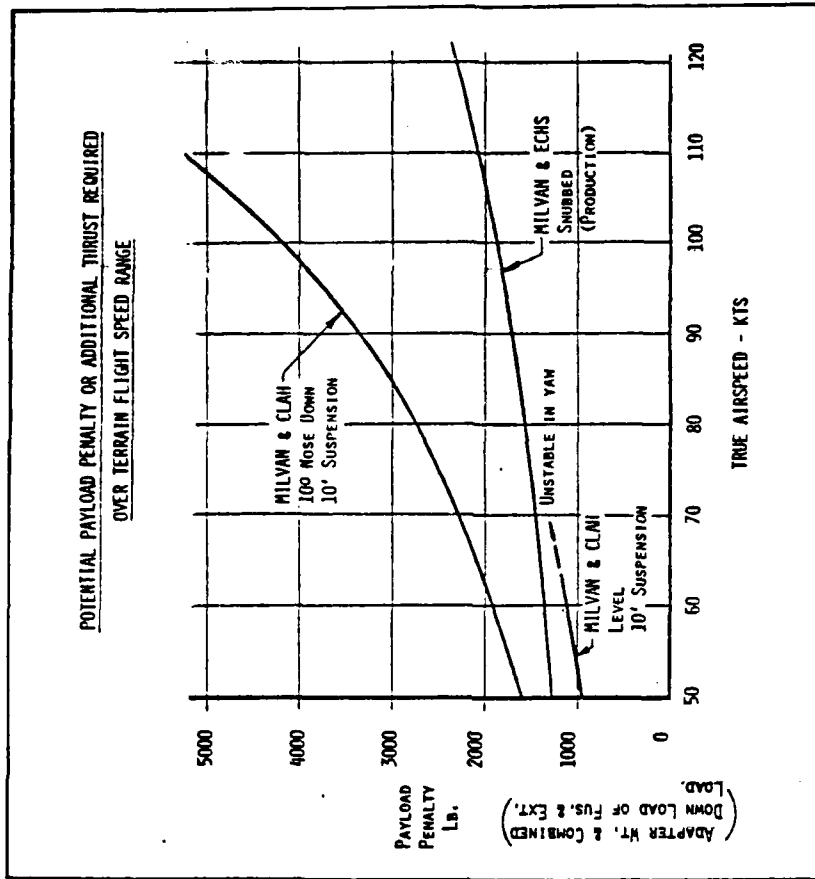
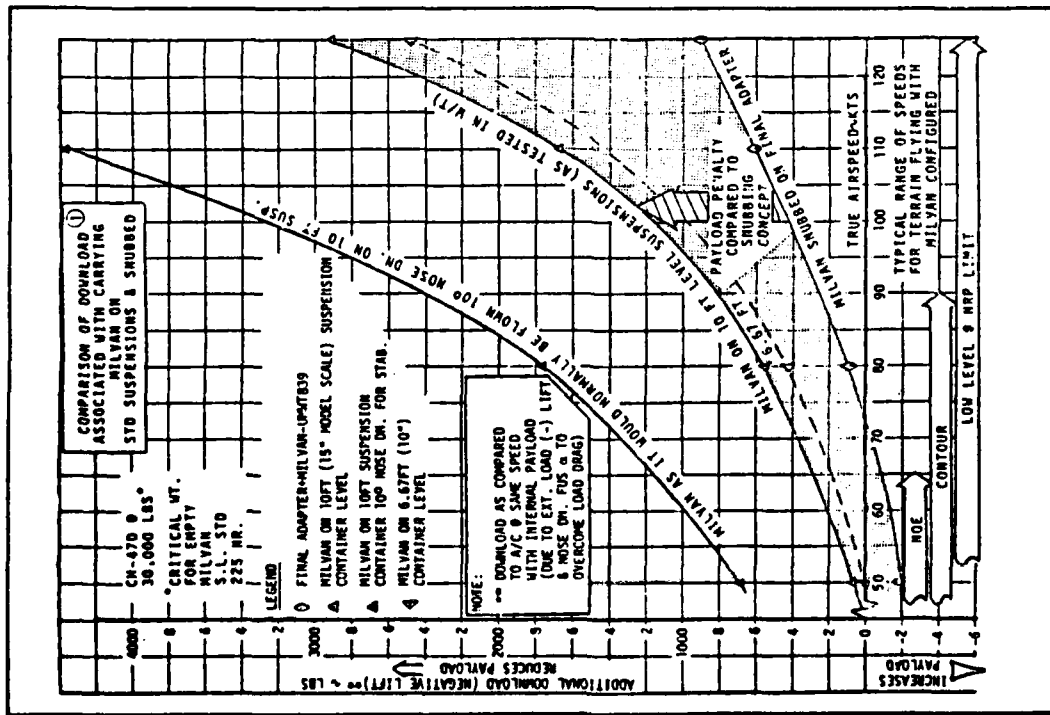

Figure 5.24 Comparison of MILVAN Carried on Conventional and Snubbed Suspensions

within the low level terrain flight speed range), the snubbed download advantage has grown to over 3800 lbs.

By adding the projected empty weights of the snubbing adapter (1461 lbs for the production version) and the CLAH (903 lbs) to their respective download curves, the potential cruise payload penalty (or required thrust increase to overcome download and empty weight delta) is derived (right hand plot). This curve clearly demonstrates the potential advantages of load snubbing.

To complete the download picture, results of snubbing MILVAN containers at various heights below a powered tandem rotor helicopter model in hover (during the HLH program) were analyzed, and corrected for CH-47D configuration differences. Test results clearly showed that hover download on a snubbed container would be negligible (and might in fact reduce the overall aircraft download, because of an improved vertical fuselage fineness ratio).

On the other hand, when the load was mounted away from the fuselage, at simulated suspension lengths of from 10 to 20 feet, substantial downloads were encountered. Hover download projections for the CH-47/MILVAN combination (based on these wind tunnel results) are listed below:

Δ Download (Standard Suspension - Snubbed Config) ~ Lbs

	<u>SUSPENSION LENGTH</u>	<u>10 FT</u>	<u>15 FT</u>	<u>20 FT</u>
FOR 30,000 LB A/C		440	580	700
50,000 LB A/C		730	950	1160

Obvious from this table is the advantage that load snubbing carries over conventional external suspension methods. Even accounting for the (558 lb) empty weight difference between the CLAH and final snubbing system, the ECHS has a potential payload advantage for most practical flight gross weights.

This advantage can be realized for terrain flying missions, because takeoff gross weight is not predicated on O.G.E. hover capability alone, as in most mission scenerios. For terrain flight, the pilot must have O.G.E. hover power available, plus additional torque ranging from 5% upwards to over 15% (depending on the intended mission); in order to perform the various avoidance and bob or pop-up maneuvers required to evade the enemy. This extra torque available can be used to overcome additional download, during hovering as the load is being hoisted to the snubbed position.

5.3 GONDOLA AERODYNAMIC EVALUATION

The photographs in Figures 5.25 and 5.26 illustrate the configuration variations evaluated with the loaded and empty prototype Gondola container during the snubbed load wind tunnel test. Until this testing was accomplished at the University of Maryland, no aerodynamic force and moment data was available for the various Gondola arrangements. Because of this lack of basic aerodynamic information, the Army was interested in developing a set of baseline aerodynamic characteristics for this type of 8 x 8 x 20 foot container, installed first on simulated sling suspensions (with inverted "Vee" struts), and then on the snubbing adapter. One of the typical loads flown earlier in an Army flight test assessment of the prototype Gondola was built by the wind tunnel model shop, for evaluation during the UMWT 839 test. This was the FARRP (Forward Area Rearm and Refuel Point) combined ammunition and fuel bladder load.

Figures 5.27 through 5.30 summarize aerodynamic characteristics measured for the empty and loaded Gondolas, while mounted on an inverted "Vee" strut level suspension that locates the container 10 inches (or 7 feet full scale) from the fuselage bottom. Figures 5.31 through 5.34 represent fuselage plus "Vee" strut only tare data; which when deducted from the runs with the Gondola installed (Figures 5.27-5.30), will produce the Gondola only aero characteristics desired. It should be noted that the resulting Gondola force and moment data will include the aerodynamic interference of the CH-47 fuselage on the Gondola; but this is probably small for the load/fuselage separation used, in the angle of attack range of interest.

In addition to the Gondola drag shown in Figure 5.27, also shown for comparison is a MILVAN on the same length suspension. As shown here (and in Figure 1.9 in the Summary), loaded Gondolas have essentially the same aerodynamic characteristics as a MILVAN. When empty, this container has about 15 ft² less drag in the cruise range.

Figures 5.35 through 5.38 depict Gondola aero characteristics with the device mounted on the streamline snubbing adapter. Drag and lift characteristics, along with static stability levels are similar to those of a snubbed MILVAN when the Gondola is loaded. A 15 ft² drag reduction was produced (just as it was on the conventional suspension), when the FARRP load was removed.

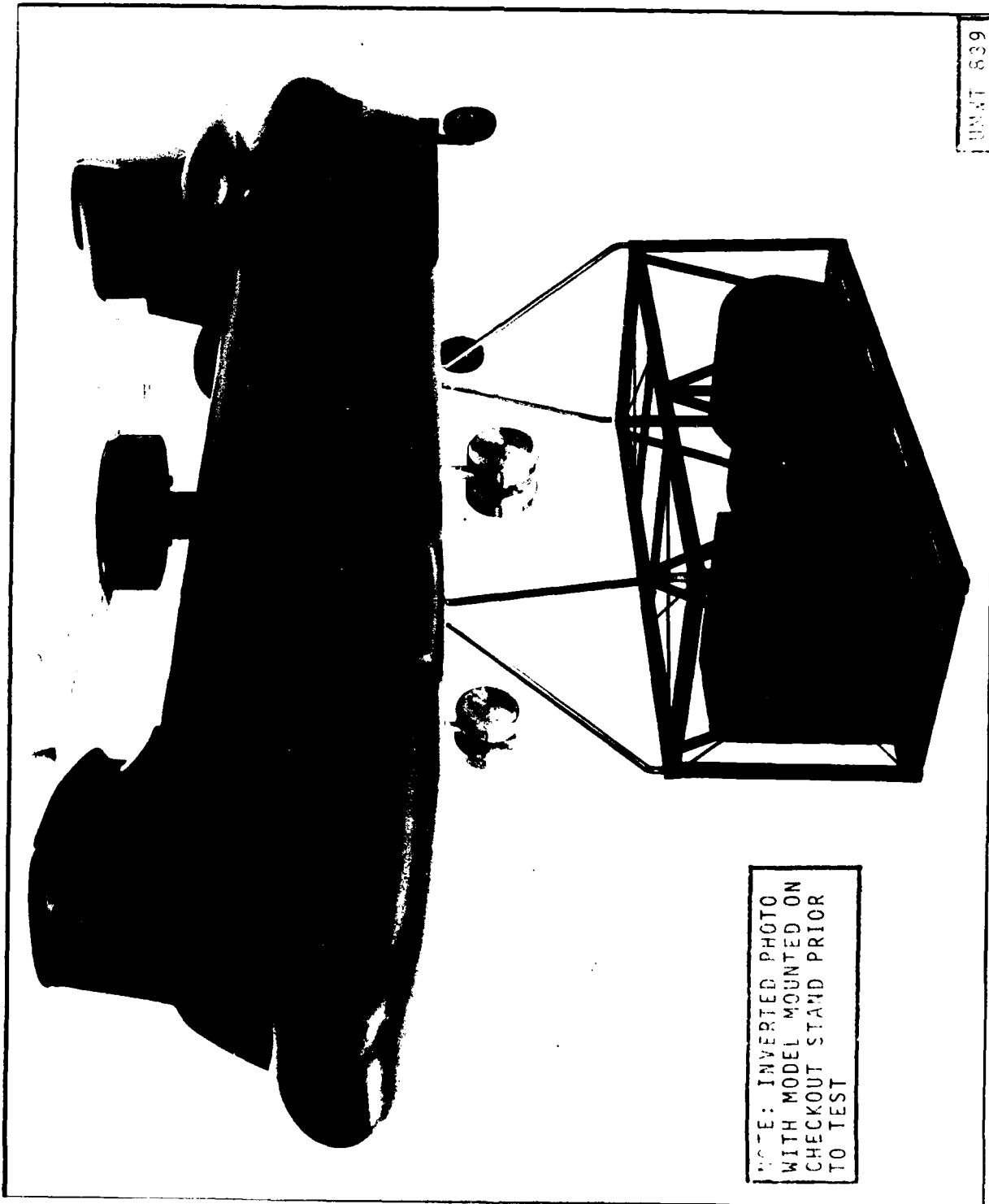
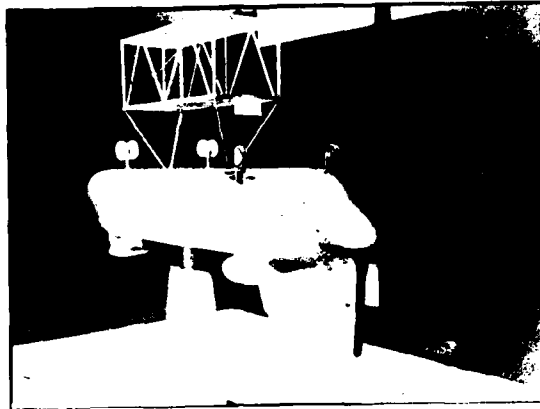
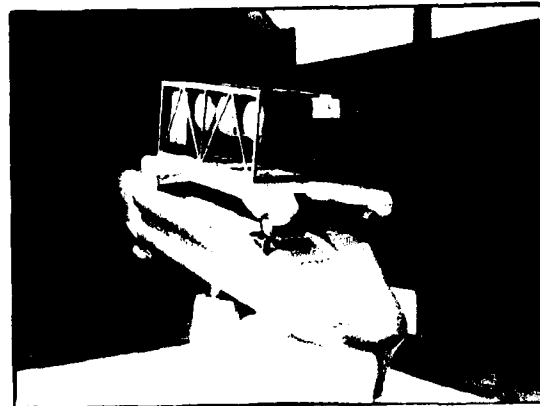

Figure 5.25 CH-47 Model with Load Gondola Mounted on Simulated Inverted "Vee" Suspension Slings



EMPTY GONDOLA ON "VEE" STRUTS SIMULATING LEVEL SLING SUSPENSION
& PLACING CONTAINER 10 IN. (6.67 FT F.S.) FROM A/C BOTTOM

Note: .020 Inch Music Wire Braces Supporting Load Laterally



GONDOLA WITH TYPICAL F.A.R.R.P. LOAD
ON STREAMLINE ADAPTER

Figure 5.26 Gondola Aerodynamic Evaluation

WIND TUNNEL TEST
 REPORT NO. 5.27

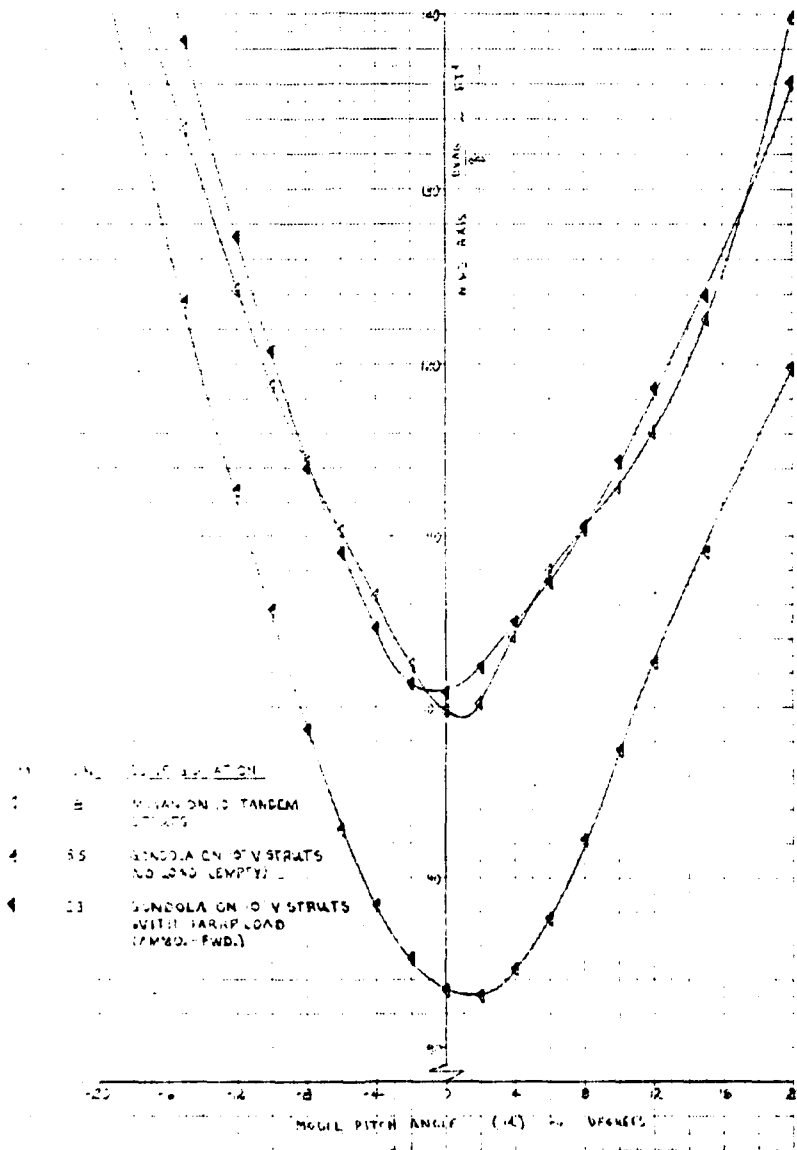

Figure 5.27 Effect of Internal Load on Gondola Aerodynamics - Drag

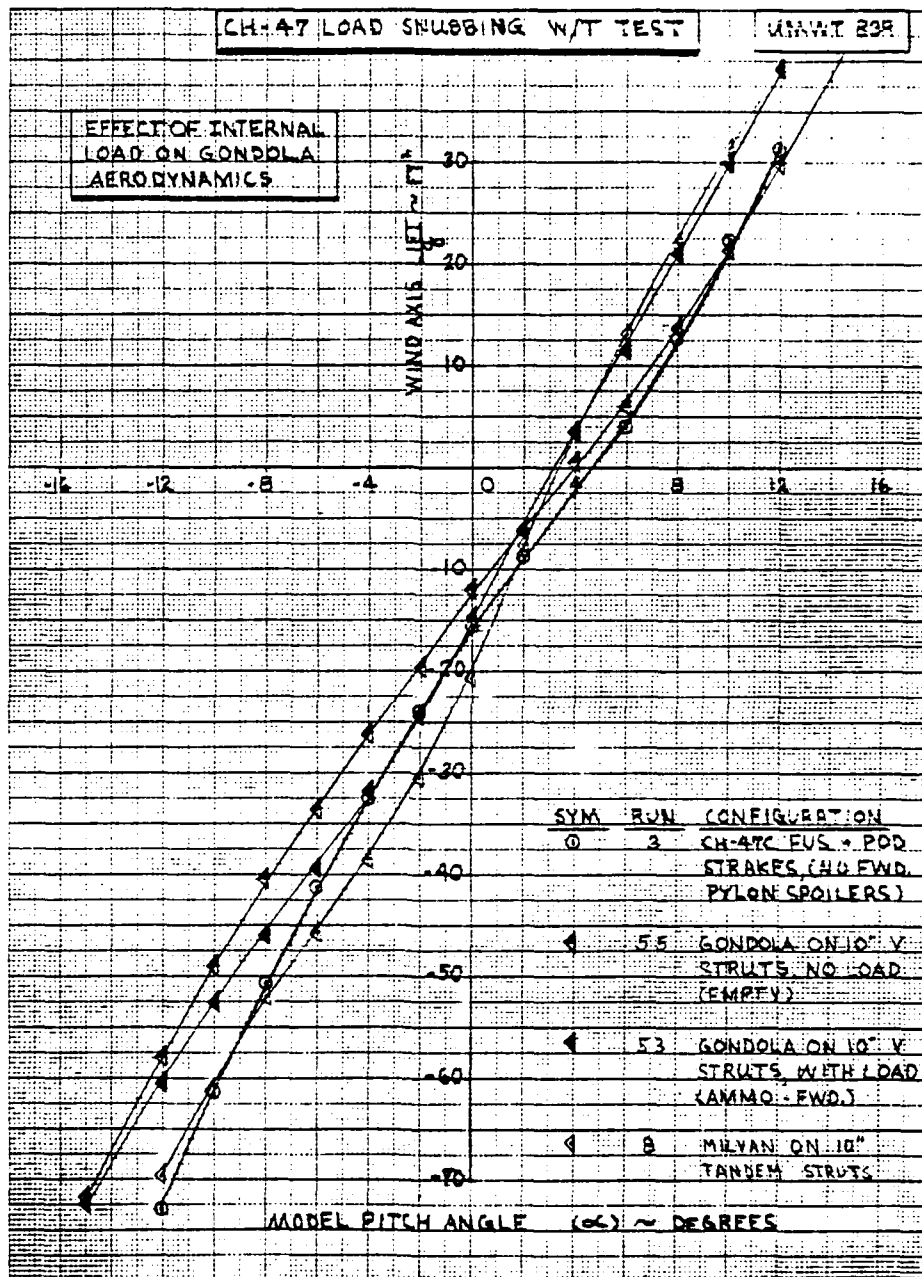

Figure 5.28 Effect of Internal Load on Gondola Aerodynamics - Lift

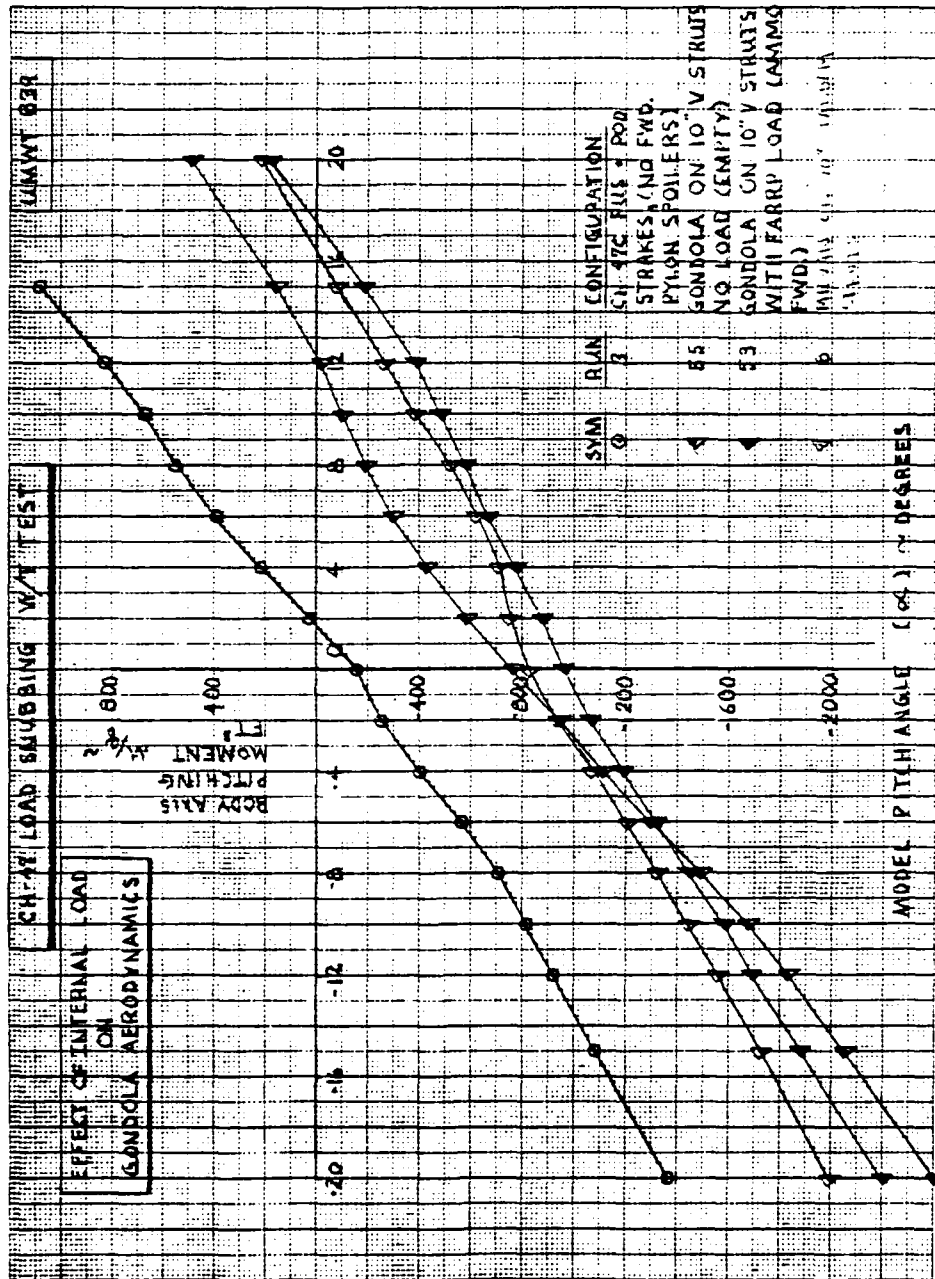

Figure 5.29 Effect of Internal Load on Gondola Aerodynamics - Pitching Moment

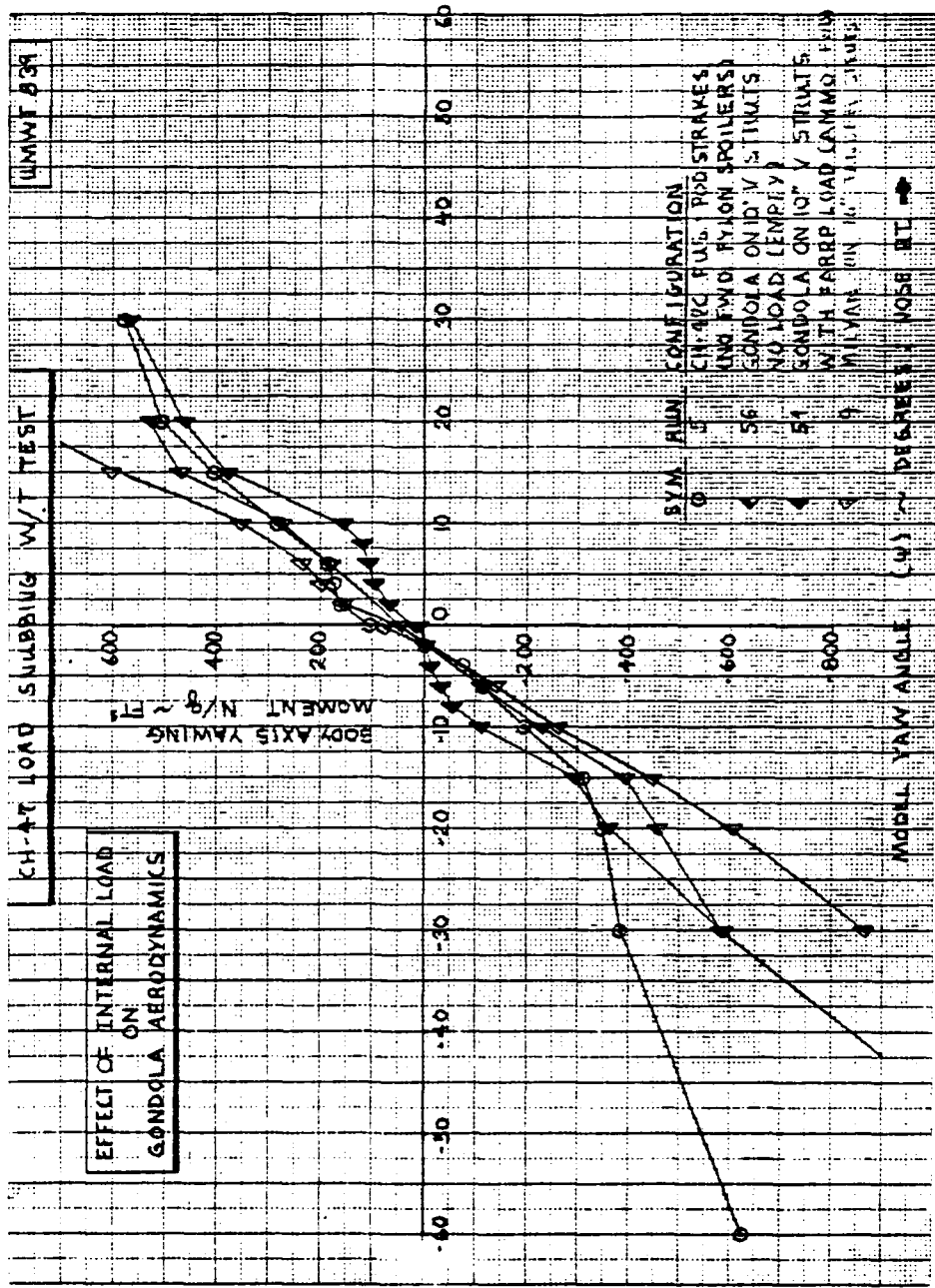

Figure 5.30 Effect of Internal Load on Gondola Aerodynamics - Yawing Moment

EFFECT OF 10" V STRUTS
ON FUSELAGE DRAG

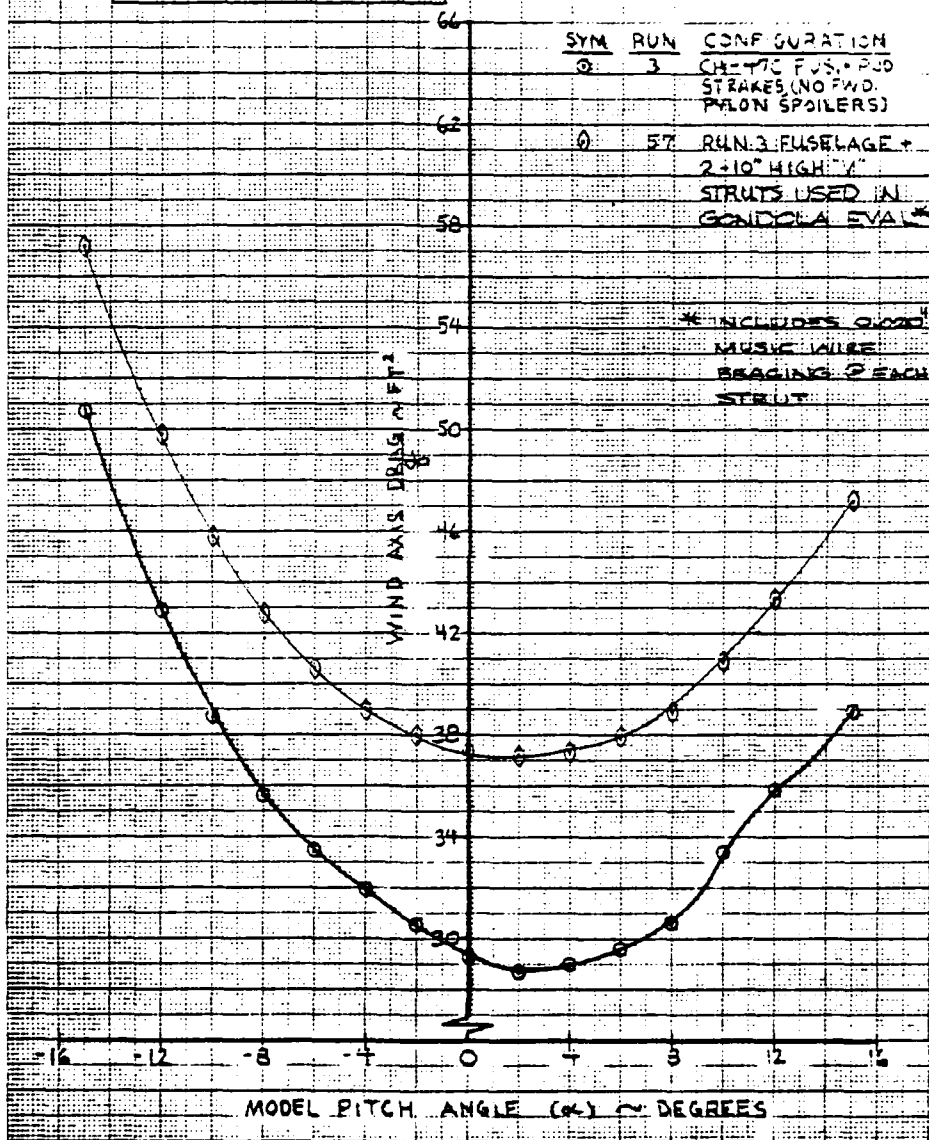

Figure 5.31 Effect of 10" "Vee" Struts on Fuselage Drag

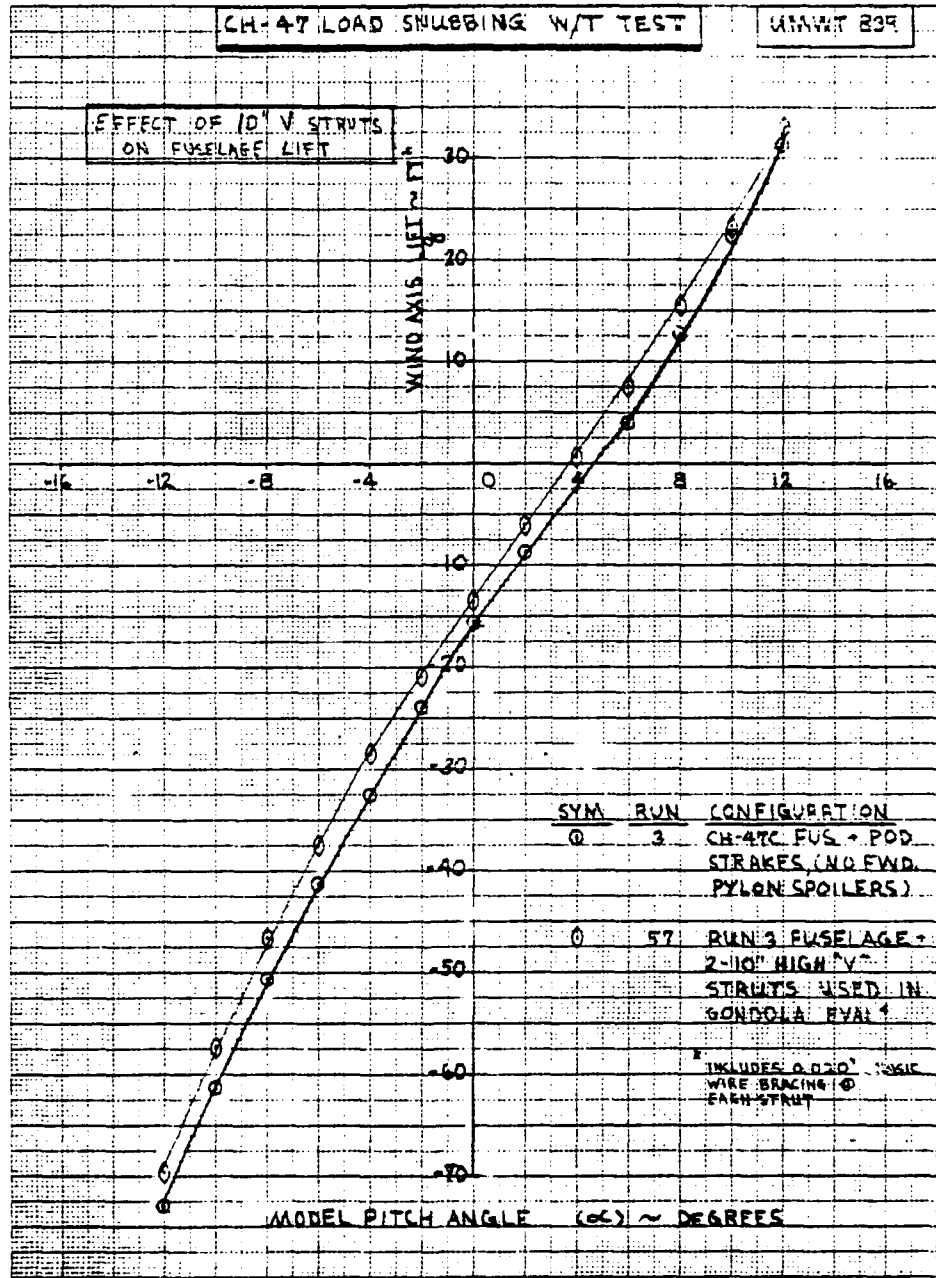

Figure 5.32 Effect of 10" "Vee" Struts on Fuselage Lift

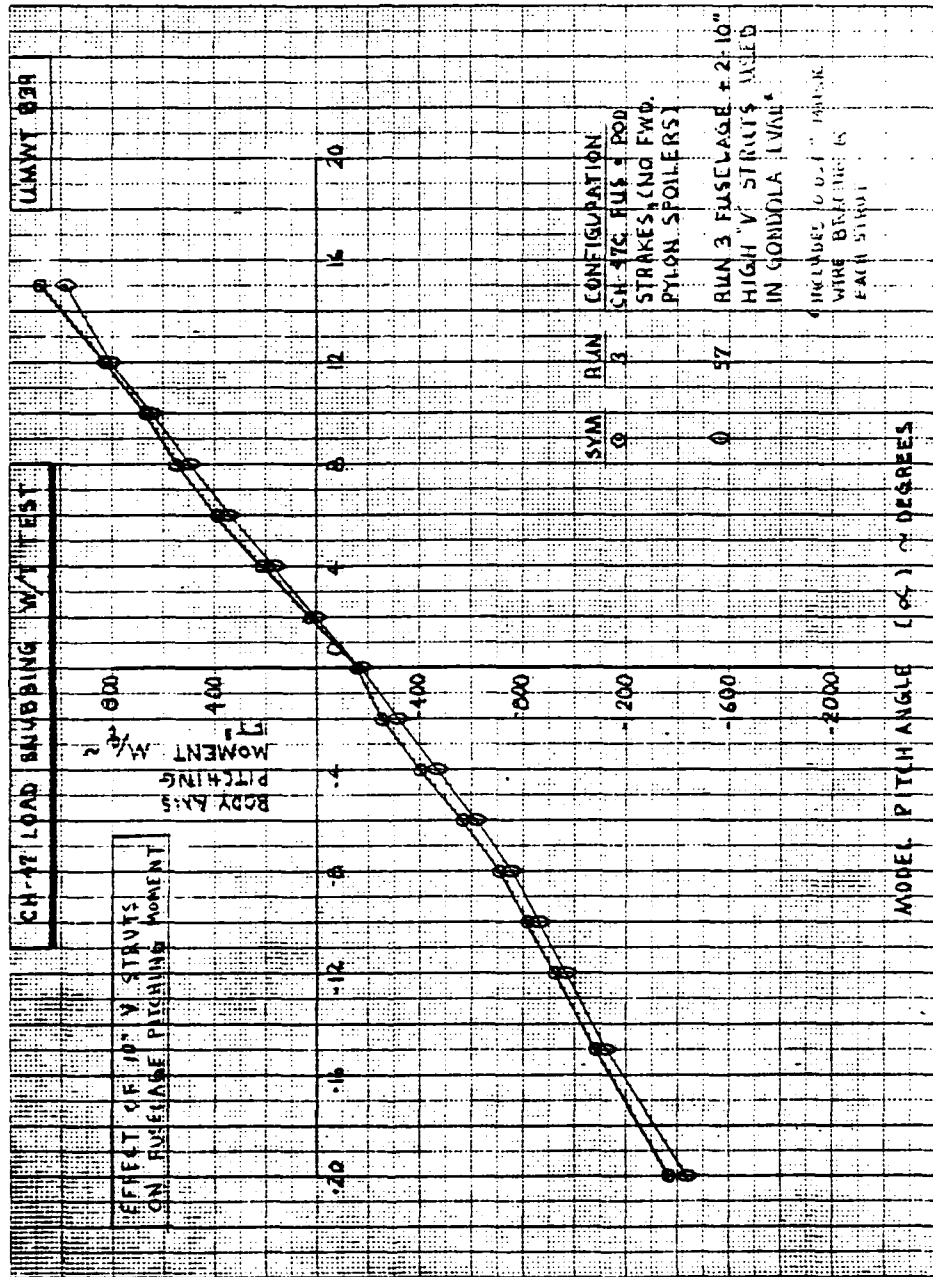

Figure 5.33 Effect of 10" "Vee" Struts on Fuselage Pitching Moment

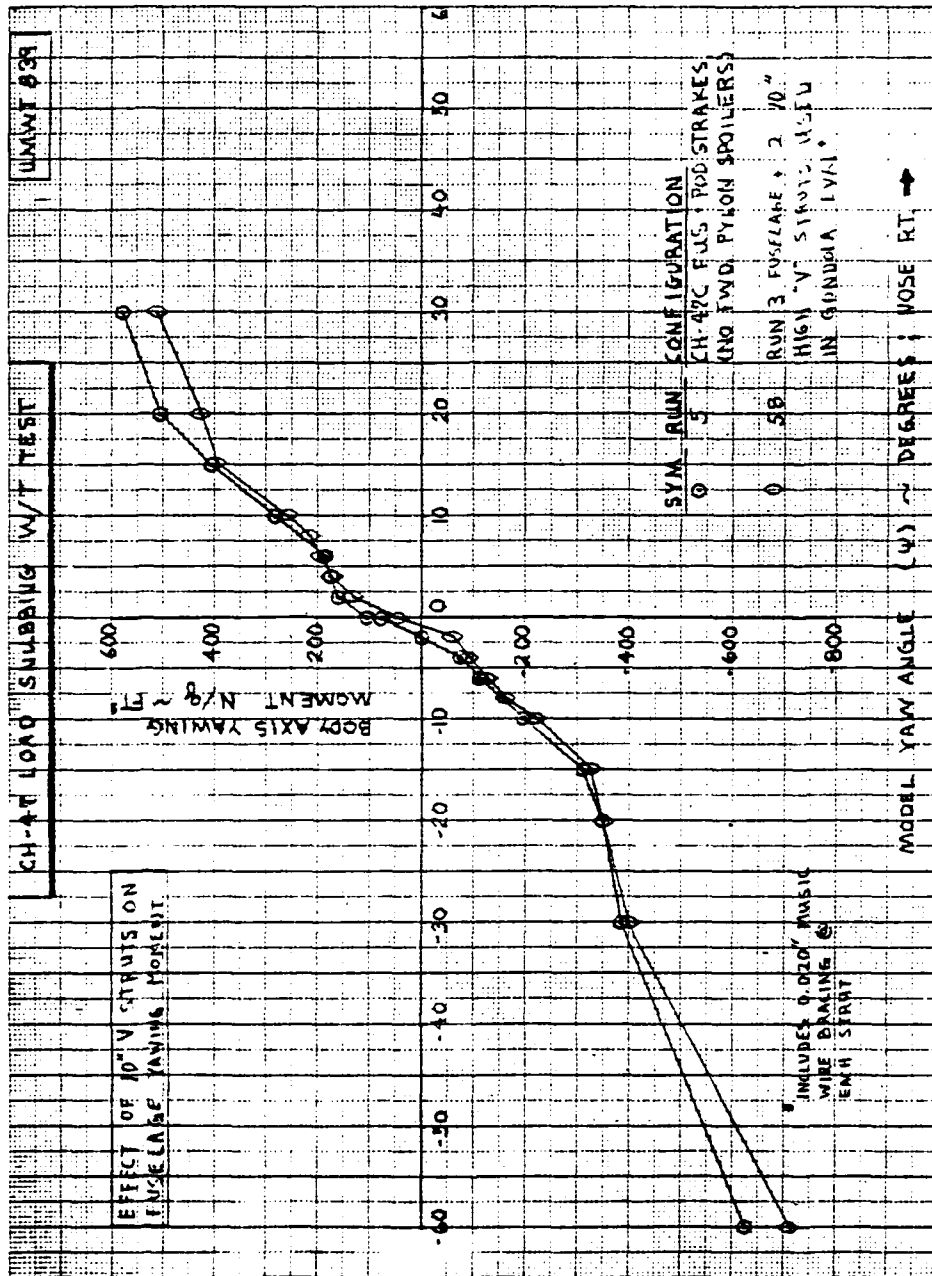

Figure 5.34 Effect of 10" "Vee" Struts on Fuselage Yawing Moment

30/37 MILVAN ON STREAMLINED ADAPTER

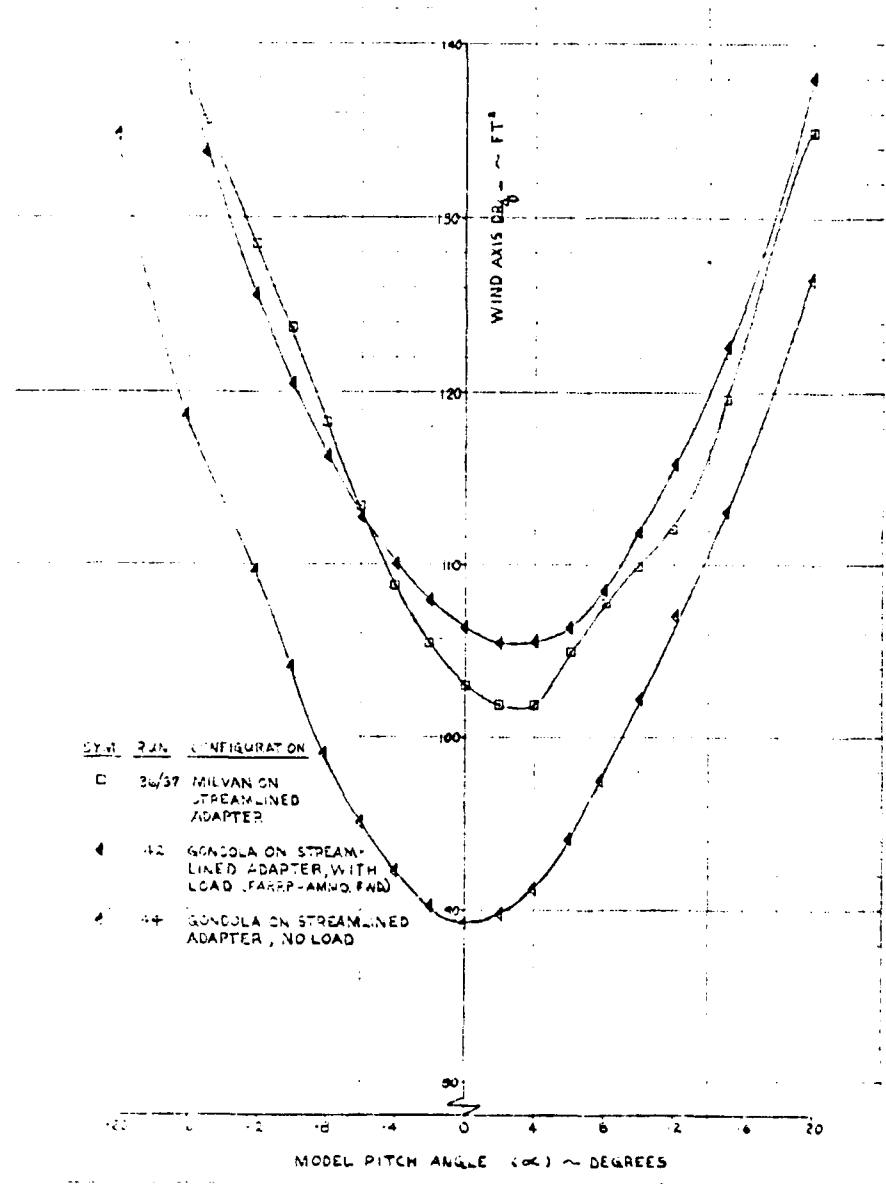

Figure 5.35 Gondola/MILVAN Comparison on Snubbing Adapter - Drag

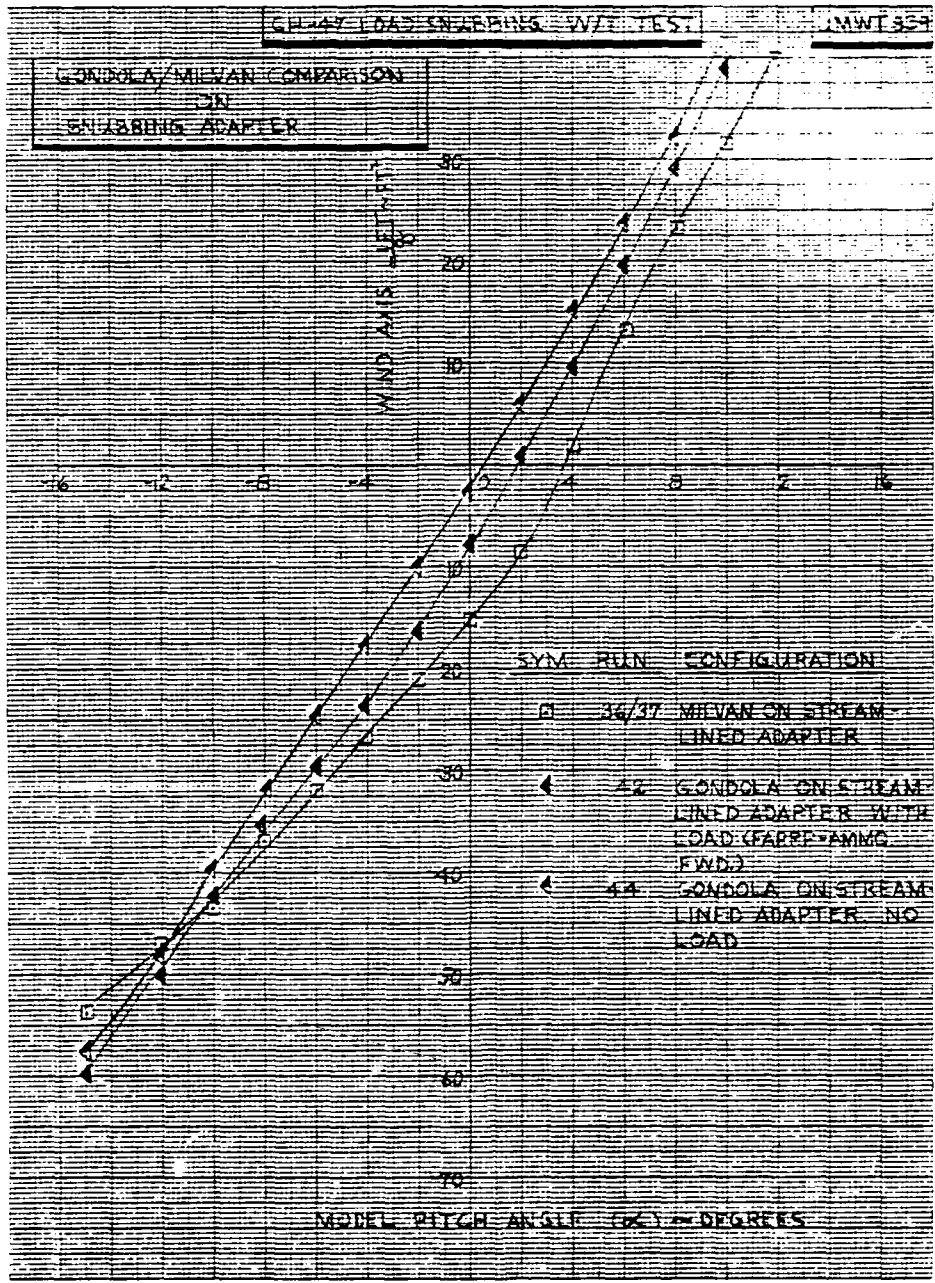

Figure 5.36 Gondola/MILVAN Comparison on Snubbing Adapter - Lift

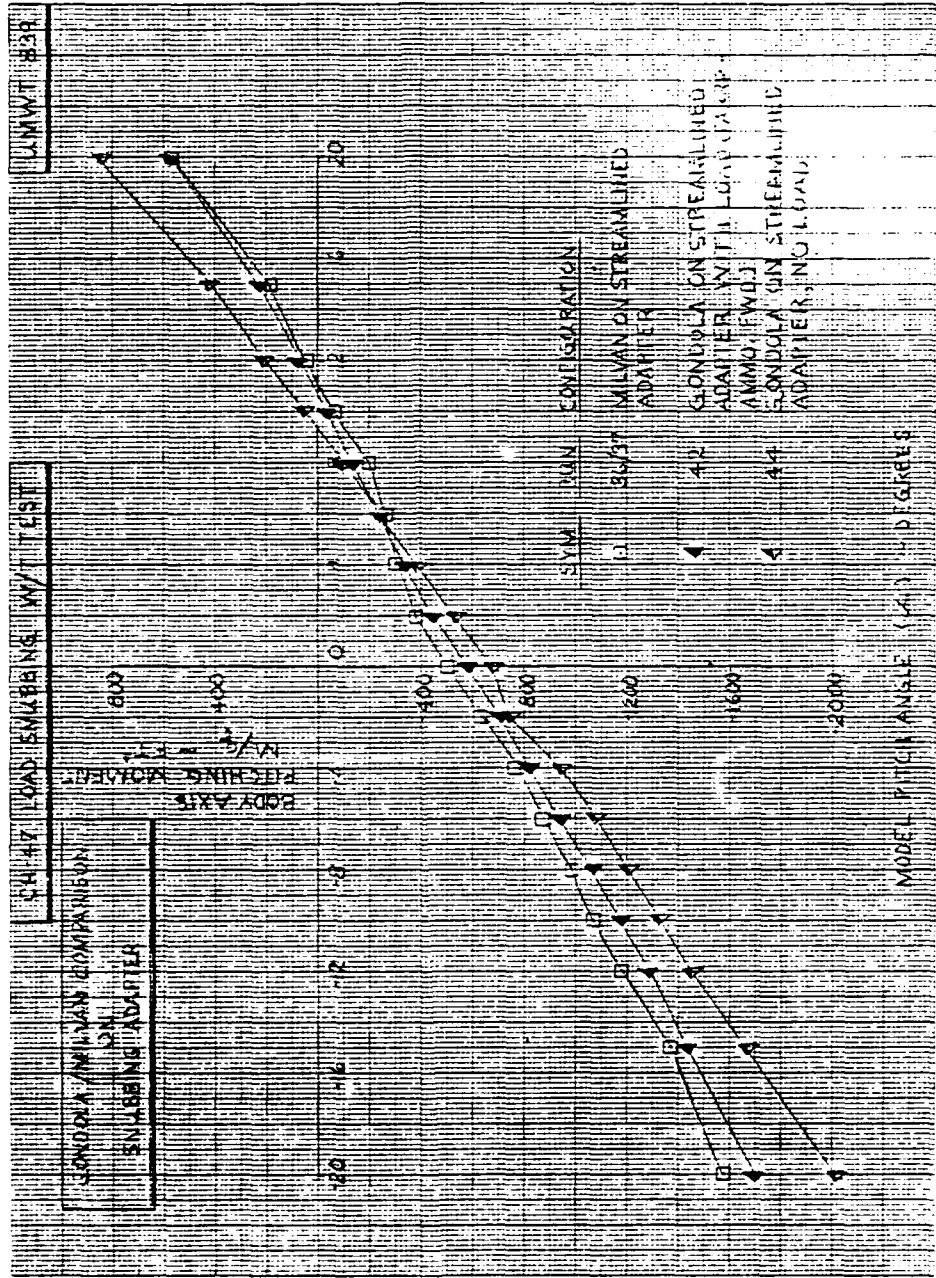

Figure 5.37 Gondola/MILVAN Comparison on Snubbing Adapter - Pitching Moment

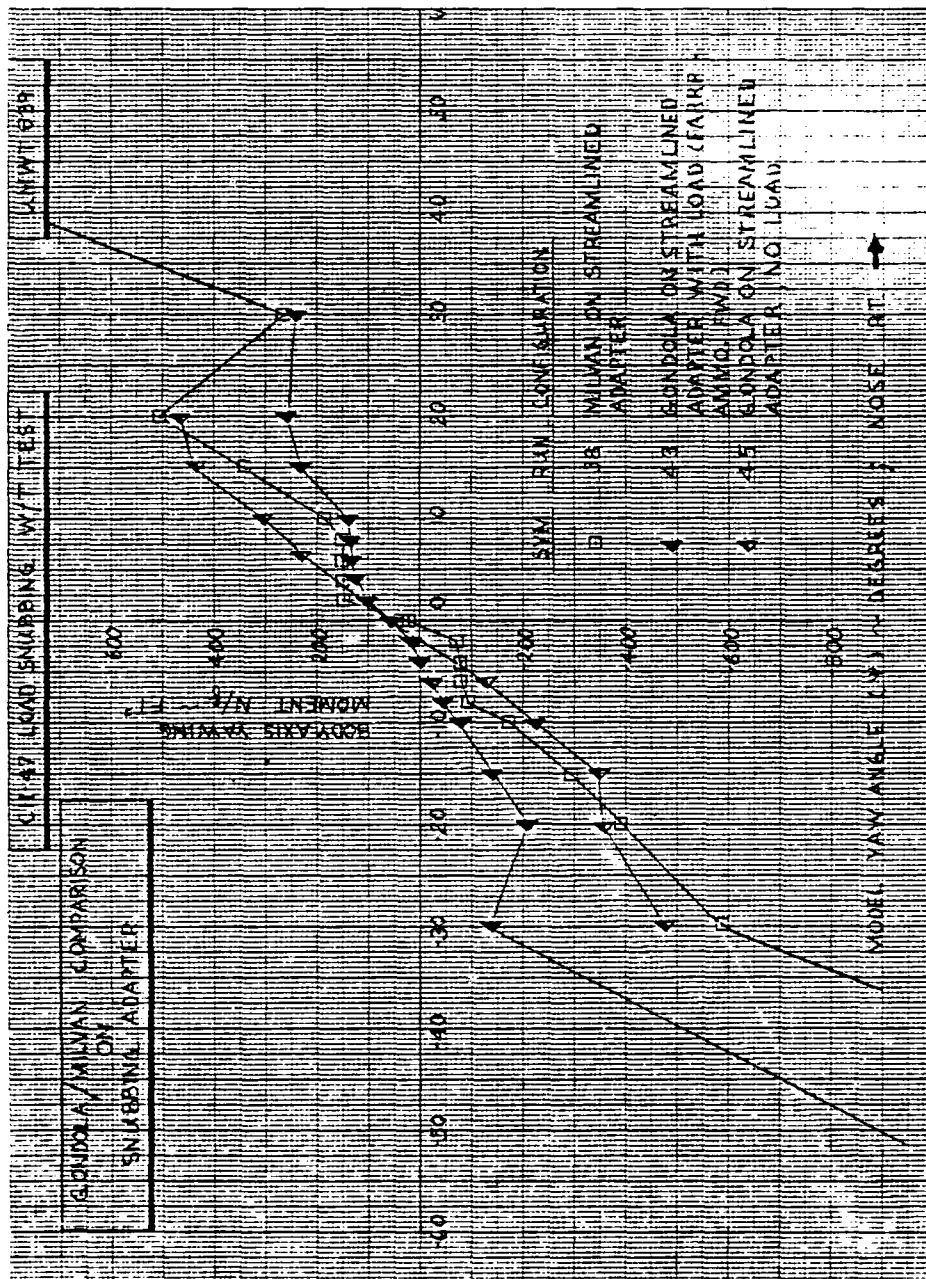

Figure 5.38 Gondola/MILVAN Comparison on Snubbing Adapter - Yawing Moment

6.0 CONCLUSIONS

1. A load snubbing External Cargo Handling System (ECHS) concept employing an adapter type framework, and multiple guide arm installation for load acquisition and alignment with corner twistlocks (which attach the load to the adapter), was selected for development. The system has the potential for simple and reliable load acquisition and deposit, without requiring pre-rigging of cargo or use of ground crew personnel. Also not required are sophisticated linear-velocity control modes for the aircraft AFCS (of the type employed in the HLH to facilitate load acquisition and deposit). Features of the system developed during the preliminary design effort include:
 - Snubbing the adapter against the landing gear, which provides partial load vibration isolation.
 - Providing additional isolation at the tandem hoist mounts, with installation of lightweight non-linear spring devices.
 - Lowering or raising the adapter, to first acquire and then snub the load, through application of two six horsepower electrically powered hoists, mounted at either end of the adapter, and employing 0.625 inch HLH type flexible hoisting cable. A preliminary hoist design developed by the Breeze Corporation for the ECHS meets requirements for load snubbing established at the start of the program.
 - A carry-on electrical control and power supply interface system, which requires installation aboard the aircraft only when use of the snubbing system is anticipated.
 - ECHS/aircraft system installation requires only AC and DC power receptacles, and an interconnect with the landing gear squat switch - AFCS signal, to disable this signal during flight with snubbed loads.
2. Installation of the ECHS requires no structural/airframe modifications to the CH-47 aircraft whatsoever.
3. The snubbing adapter framework for the prototype demonstrator ECHS unit will be fabricated using

conventional sheet and stringer construction, with a total weight (including hoists, cables, guides, twistlocks, etc) of 1873 lbs - use of graphite and Kevlar composite structural elements will reduce system weight to 1461 lbs for production versions of the ECHS. The production ECHS will only exceed the weight of the conventional suspension CLAH adapter by 558 lbs, which is more than compensated for by the substantially lower hover and cruise aerodynamic download experienced with the snubbed configuration. Because of this reduced download, flight with a snubbed load enjoys a performance advantage over conventional suspensions flown with a CLAH.

4. Alignment guide arm and twistlock attachment systems, developed for the CLAH, have been retained in design of the ECHS.
5. A "Generalized" wind tunnel evaluation of the load snubbing concept revealed that load snubbing does not create aerodynamic problems, and in fact, produces a favorable interference between the load and fuselage which:
 - reduces drag and download as the snubbed load approaches the fuselage
 - provides for a neutral pitch stability ($M\alpha$) contribution of the load relative to the fuselage
 - provides substantially improved static directional ($N\beta$) stability levels at low yaw angles (of over $55 \text{ ft}^3/\text{degree}$), relative to the bare fuselage.
6. A wind tunnel aerodynamic cleanup of the original Phase II/III adapter/MILVAN assembly produced a "final" ECHS adapter configuration with 20 ft^2 less drag (equivalent to 4-5 knots speed delta at NRP, or a 400 SHP reduction), and greatly reduced download (relative to the fuselage) in the negative angle of attack cruise range. A neutral pitch stability contribution of the snubbed load, and improved yaw stability ($\approx 35 \text{ ft}^3/\text{degree}$), are also characteristic of the configuration.
7. Tunnel aerodynamic evaluation of the loaded Gondola container showed results similar to those of the MILVAN both when mounted on suspensions away from the fuselage, and when installed on the snubbing adapter. Removal of the FARRP load reduced drag by 15 ft^2 .

7.0 RECOMMENDATIONS

1. Continued development of the load snubbing-against-the-gear ECHS concept is recommended to produce detail designs suitable for fabrication of a prototype demonstration system.
2. In implementing detail design of the ECHS, the following items need to be carefully considered:
 - An in-depth vibration/isolation dynamics analysis of the final structural design for prime, as well as secondary vibratory modes, to ensure synthesis of proper isolator design parameters
 - An in-depth structural load and stress analysis of the final detail design, using aerodynamic force and moment data acquired during the snub load wind tunnel program
 - A flight simulation using the final detail structural and isolator design information and snub load wind tunnel results, to improve math modeling fidelity and to review and assess capability of the aircraft for performing terrain maneuvers with the final ECHS prototype configuration
 - A comprehensive air-resonance analysis of the final prototype ECHS design, to include a sufficient number of degrees of freedom for defining characteristics of all potential troublesome modes
 - An analysis to determine potential degradation of electronic system functions (especially as related to NAV/COM gear and antennae located on the aircraft bottom), likely to be influenced by the proximity of the load; and a determination of changes in this equipment necessary to ensure proper operation when the aircraft is configured with a snubbed MILVAN or Gondola
 - A further investigation into potential effects of the snubbed load on landing gear oleo strut seal function and MTBO life, using the final prototype adapter design when completed
3. A bench endurance vibration test (to evaluate oleo seal life) should be conducted prior to flight, using a single wheel pad from the snubbing adapter and a combined landing gear strut & wheel assembly.

4. A structural bench testing of the device should be performed to confirm load carrying capability at design conditions, including simulated failure of one suspension. This testing should include hoist operation and performance evaluation for loads up to 25,000 lbs.
5. After fabrication of the prototype ECHS device, plan a conservative flight test functional, handling qualities, and performance assessment program; employing an instrumented CH-47D aircraft, and utilizing build-up evaluations to ensure freedom from air-resonance type problems, structural or functional problems etc.. Instrumentation, in addition to that required to ensure load attachment structural integrity, should include standard flying qualities rate, attitude, and acceleration packages, in addition to instrumentation for assessing fuselage and load vibration characteristics. Gear oleo strut deflection should be recorded to assess squat switch/AFCS signal functional requirements.

8.0 REFERENCES

1. Alansky, I., Davis, J., and Garnett, T., "Limitations of the CH-47 Helicopter in Performing Terrain Flying with External Loads," Boeing Vertol Company, Contract Number DAAJ02-76-C-0028, August 1977, USAAMRDL-TR-77-21.
2. Contract Number DAAJ02-77-C-0069, "Design and Analysis of CH-47 External Cargo Handling System (Snubbed Load)" issued by U.S. Army Research and Technology Laboratories, Fort Eustis, Virginia, 1977.
3. Campbell, R., Szewczyk, V., Wilson, G., "Design for Militarized Helicopter Transported Container Handling Device," report number D210-11029-2, Boeing Vertol Company, December 1976.
4. Simpson, L., "Militarized Container Handling Device Interface Component Design," report number D210-11029-3, Boeing Vertol Company, May 1977.
5. Campbell, R.F., Wilson, G., "Heavy Lift Helicopter - Cargo Handling ATC Program, Volume 1," Boeing Vertol Company, January 1976, USAAMRDL-TR-74-97A.
6. Field Manual 90-1, "Employment of Army Aviation Units in a High Threat Environment," Headquarters, Department of the Army, Washington, D.C., 30 September 1976.
7. Field Manual 1-1, "Terrain Flying," Headquarters, Department of the Army, Washington, D.C., 1 October 1975.
8. Davis, J., Garnett, T., Gaul, J., "Heavy Lift Helicopter Flight Control System - Volume III," Boeing Vertol Company, September 1977, USAAMRDL-TR-77-40C.
9. Teare, P., "YCH-47D Mechanical Instability Analysis," report number 145-DY-702, Boeing Vertol Company, March 1978.
10. "A Proposal for the Fabrication and Testing of a Container Lift Adapter - Helicopter," report number D210-11268-1, prepared by Boeing Vertol Company, June 1978, RFQ number DAAK51-78-Q-0069.
11. Hodder, D.J., "UMWT 839: A Low Speed Wind Tunnel Test of CH-47 with Snub Load Adapter," report number 8-7891-1-445, Boeing Vertol Company, April 1979.

APPENDICES

- A. CH-47 EXTERNAL CARGO HANDLING SYSTEM
(SNUBBED LOAD): CRITICAL ITEM DEVELOPMENT
SPECIFICATION (CIDS)
- B. SNUB LOAD WIND TUNNEL TEST DATA REPORT
- C. BREEZE CORPORATION, HOIST PROPOSAL

APPENDIX A

CH-47 EXTERNAL CARGO HANDLING SYSTEM

(SNUBBED LOAD)

CRITICAL ITEM DEVELOPMENT SPECIFICATION (CIDS)

REV LTR

THE **BOEING** COMPANY
VERTOL DIVISION · MORTON, PENNSYLVANIA

CODE IDENT. NO. 77272

NUMBER D210-11381-1

TITLE EXTERNAL CARGO HANDLING SYSTEM (SNUBBED LOAD)
PRELIMINARY CRITICAL ITEM DEVELOPMENT

SPECIFICATION

FOR LIMITATIONS IMPOSED ON THE USE OF THE INFORMATION
CONTAINED IN THIS DOCUMENT AND ON THE DISTRIBUTION
OF THIS DOCUMENT, SEE LIMITATIONS SHEET.

MODEL _____ CONTRACT DAA-J02-77-C-0069

ISSUE NO. _____ ISSUED TO: _____

PREPARED BY	<u>R.F. Campbell</u>	DATE	<u>9/21/79</u>
APPROVED BY	<u>T.S. Garnett</u>	DATE	<u>9/21/79</u>
APPROVED BY	<u>B.B. Blake</u>	DATE	<u>9/21/79</u>
APPROVED BY	<u>W.L. Weller</u>	DATE	<u>1/17/80</u>

FOREWORD

This Critical Item Development Specification provides a preliminary definition for an external cargo handling system applicable to the Boeing Vertol CH47D model helicopter. The cargo handling system will interface with a standard commercial 8 x 8 x 20 ISO container, a MILVAN container and the proposed family of Gondola designs. The system includes provisions to acquire and lock onto the payload, and a hoisting system to permit the load to be snubbed against the aircraft.

The illustrations in this specification are included as a guide for further development. It is not intended that these illustrations should restrict or inhibit the system development and alternative approaches should be considered consistent with the intent of this specification.

TABLE OF CONTENTS

	<u>PAGE</u>
FOREWORD	ii
1.0 SCOPE	1
2.0 APPLICABLE DOCUMENTS	1
3.0 REQUIREMENTS	3
3.1 Background	3
3.1.1 System Description	4
3.1.1.1 ECHS Structural Arrangement	11
3.1.1.2 Twistlock System	15
3.1.1.3 Guide System	15
3.1.1.4 Hoist System	15
3.1.1.5 Electrical System	18
3.2 Characteristics	18
3.2.1 Performance	18
3.2.1.1 Structural Criteria	18
3.2.1.2 Hoist Criteria	20
3.2.1.3 Load Isolators	24
3.2.1.4 Twist Lock System Criteria	26
3.2.1.5 Guide System Criteria	29
3.2.1.6 Control System Criteria	29
3.2.2 Physical Characteristics	33
3.2.2.1 Weight	33
3.2.2.2 Size	33
3.2.2.3 Transport & Storage Requirements	34
3.2.2.4 Durability	34
3.2.3 Reliability	34
3.2.3.1 Mission Reliability	35
3.2.3.2 System Operational Reliability	35
3.2.2.2 Mean Time Between Unscheduled Removals	35
3.2.4 Maintainability	35
3.2.4.1 Corrective Maintenance Manhour to Flight Hour Rates	36
3.2.4.2 Preventive Maintenance Manhour to Flight Hour Rates	36
3.2.4.3 Turnaround Time	36
3.2.5 Environmental Conditions	36
3.3 Design and Construction	36
3.3.1 Materials, Process & Parts	36
3.3.1.1 Materials	37
3.3.1.2 Standard Parts	37
3.3.1.3 Straight Screw Threads	37
3.3.1.4 Safetying	38

TABLE OF CONTENTS
Continued

	<u>PAGE</u>
3.3.2 Electrically Operated Components	38
3.3.2.1 Voltage Range	38
3.3.2.2 Dielectric Strength	38
3.3.2.3 Electric Motors	38
3.3.3 Nameplates & Product Markings	38
3.3.3.1 Marking	38
3.3.3.2 Identification	38
3.3.4 Workmanship	38
3.3.5 Interchangeability & Replaceability	39
3.3.6 Safety	39
3.3.7 Human Performance/Human Factors Engineering	39
3.4 Logistics	39
3.4.1 Maintenance	39
3.5 Precedence	39
4.0 QUALITY ASSURANCE PROVISIONS	39
4.1 General	39
4.2 Component Qualification Tests	39
4.2.1 Hoist Assembly	39
4.2.2 Load Isolator	39
4.2.3 Twistlock Actuator	40
4.2.4 Hoist Control System	40
4.2.5 Structural Tests	40
4.2.5.1 Limit Load Tests	40
4.2.5.2 Ultimate Load Test	40
4.2.5.3 Guide Impact Test	40
4.3 System Integration Tests	40
4.3.1 Twistlock System	41
4.3.2 Hoist System	41
4.3.3 Landing Gear Oleo	41
4.4 Flight Tests	41

LIST OF ILLUSTRATIONS

<u>Figure</u>		<u>Page</u>
1	ECHS General Arrangement	5
2	ECHS Acquiring Load and in Snubbed Position	6
3	Electrical System Concept	8
4	Control Panel	9
5	Structural Arrangement (three pages)	12
6	Twistlock System	16
7	Twistlock Arrangement	17
8	Installation of Isolator Spring	19
9	Overcenter Latch	22
10	Cable Eye End	25
11	Isolator Requirements	27
12	Isolator Geometry	27
13	Isolator Spring Characteristics	28
14	Corner Interlock Switch	30
15	Twistlock Alignment Limits	31
16	Twistlock Position Indicators	32

LIST OF TABLES

<u>Table</u>		<u>Page</u>
1	Design Conditions	21
2	Maximum Reactions	23

1.0 SCOPE

1.1 General

This Critical Item Development Specification establishes the preliminary performance, design and development requirements for an external cargo handling system compatible with MILVANS, ISO 20 ft. containers, and proposed Gondolas, for use with the CH-47D helicopter. This specification also includes an outline of the testing the system will require.

The requirements and criteria established in this document provide the basis for a prototype system design, suitable for development into a fully qualified system.

The External Cargo Handling System - Snubbed Load (ECHS) is an interfacing system intended to permit the rapid acquisition of containerized loads by the CH-47D helicopter, forward flight without the usual restrictions of slung load, and load deposit at the end of the mission and all without the use of ground personnel.

2.0 APPLICABLE DOCUMENTS

2.1 Government Documents

The following documents form a part of this specification to the extent specified herein. These documents are effective for the dates noted. If the date is not shown, the document shall be of the issue in effect on 1 January 1973. In the event of conflict between the documents referenced herein and the contents of this specification, the contents of this specification shall apply.

2.1.1 Specifications

2.1.1.1 Military Specifications

MIL-D-1000 1 March 1965	Drawings, Engineering and Associated Lists
MIL-T-5624 30 October 1973	Turbine Fuel, Aviation, Grades JP-4 & JP-5
MIL-F-7190A Amend 1 18 September 1958	Forgings, Steel, for Aircraft and Special Ordnance Applications
MIL-S-7742B Amend 1 15 March 1973	Screw Threads, Standard, Optimum Selected Series, General Specification for
MIL-L-7808G Amend 2 10 September 1971	Lubricating Oil, Aircraft Turbine Engine, Synthetic Base

2.1.1.1 Military Specification (continued)

MIL-M-7969C 25 May 1965	Motors, Alternating Current, 400 Cycles 115/200 Volt System, Aircraft, General Specification For
MIL-I-8500C Change 1 3 May 1972	Interchangeability and Replaceability of Component Parts for Aerospace VEHICLES
MIL-S-8879A Notice 1 10 April 1977	Screw Threads, Controlled Radius Root with Increased Minor Diameter, General Specification for
MIL-L-23699B Change 2 22 November 1971	Lubricating Oil, Aircraft Turbine Engine, Synthetic Base
MIL-H-83282A 22 February 1974	Hydraulic Fluid, Fire Resistant, Synthetic Hydro-Carbon Base, Aircraft

2.1.1.2 Military Standards

MIL-STD-130D Change 1 30 June 1971	Identification Marking of U.S. Military Property
MIL-STD-143B 12 November 1969	Standards and Specifications Order of, Preference for, the Selection of
MIL-STD-704A Change 1 7 February 1968	Electric Power, Characteristics and Utilization of
MIL-STD-810C 10 March 1975	Environmental Test Methods
MIL-STD-889A 5 May 1972	Dissimilar Metals
MIL-STD-1472A 15 May 1970	Human Engineering Design Criteria for Military System, Equipment and Facilities
MS 20995	Wire, Safety or Lock
MS 2540	Safety Wiring and Cotter Pinning, General Practices for
	Washer-Limitation on Usage of Lock

2.1.1.3 Other Government Publications

AR 750-1 1 May 1972	Maintenance of Supplies and Equipment, Army Material Maintenance Concepts and Policies
TM 38-750-1 21 November 1972	Army Maintenance Management System (TAMMS) Field Command Procedures
ANA Bulletin #147 16 November 1973	Specifications and Standards of Non-Government Organizations Released for Flight Vehicle Construction
MIL-HDBK-5C 15 September 1976	Metallic Materials and Elements for Aerospace Vehicle Structures
USAAMRDL-TR-74-97A	Heavy Lift Helicopter - Cargo Handling ATC Program, Volume 1 Detail Design Structural and Weight Analysis, and Static & Dynamic Load Analysis

2.1.1.4 Contractor Documents

BMS 7-186	Aluminum Alloy Forgings
D210-11225-1	Limitations of the CH-47 Helicopter in Per- forming Terrain Flight with External Loads

2.1.1.5 Commercial Standards

ANSI ME5.4-1972	American National Standard Specifications for International (ISO) Freight Containers
-----------------	---

3.0 REQUIREMENTS3.1 Background

In order to facilitate rapid and efficient movement of supplies and equipment into forward battle areas, the CH-47 can readily carry heavy external payloads. Using the external cargo capability of this aircraft greatly reduces exposure time during offloading, permits movement of outsized loads too big for internal storage, and increases productivity appreciably when large quantities of pre-rigged equipment are to be transported. Maximizing CH-47 combat support effectiveness will not only require terrain flying with external loads, but also the potential for performing these tasks around the clock and in IMC.

Terrain flying with external loads under these conditions incurs a number of limitations; some associated with the aircraft/load combination, and others with the type of maneuvers being flown or severity of environmental restrictions imposed. A quantitative assessment of these limitations was made for the CH-47 aircraft in a two phase analytical study, conducted by Boeing Vertol during

3.1 Background - Continued

1976/77, under contract DAAJ02-76-C-0028 for the USAAMRDL Eustis Directorate.

Limitations evaluated in this study fell into several broad areas including:

- . Those associated with providing adequate load and aircraft clearance from obstacles while maneuvering close to the terrain
- . Those resulting from load motion and/or aircraft maneuverability and speed capability with the load attached
- . Those related to providing masking (which is the ability to hide the aircraft behind cover during maneuvers)
- . Those resulting from aircraft handling qualities, performance, or structural capability
- . Those resulting from night and all-weather operations.

The first phase of the study dealt with determination of aircraft and system limits, as defined by an unpiloted flight simulation of selected terrain flying maneuvers. With these limitations defined, candidate concepts for cargo and visionics system (intended to remove as many of the limits as practical) were developed and ranked. As a result of reviewing these concepts a cargo handling system consisting of a Self-Hoisting (Container Handling) Interface Device for snubbing the load against the aircraft bottom was selected for further investigation. Terrain maneuver analysis performed in the study showed the load snubbing device to be very effective in either removing, or substantially reducing, most of the limitations associated with carrying cargo on conventional external suspensions.

The snubbing system concept includes an interfacing adapter which attaches to the top of MILVAN or Gondola loads, and is winched up to the helicopter by an electrically powered self-contained hoisting system for connection to the tandem cargo hooks. The device is snubbed against the aircraft landing gear, and is attached to the aircraft structure through the triple hook arrangement of the Boeing Vertol CH-47D helicopter.

3.1.1 System Description

The general arrangement of the External Cargo Handling System (ECHS) is shown on Figure 1. Figure 2 illustrates the ECHS acquiring a 8 X 8 X 20 container, and also the ECHS and container snubbed to the helicopter in forward flight.

1. A basic structure that provides the support for the four twist-lock elements to interface with a standard ISO 20 ft. container; the six guide arms to locate and assist in inserting the twist-locks into the container; two hoists and their associated system to permit the ECHS to snub against the aircraft. The

BOEING COMPANY

NUMBER
REV LTR

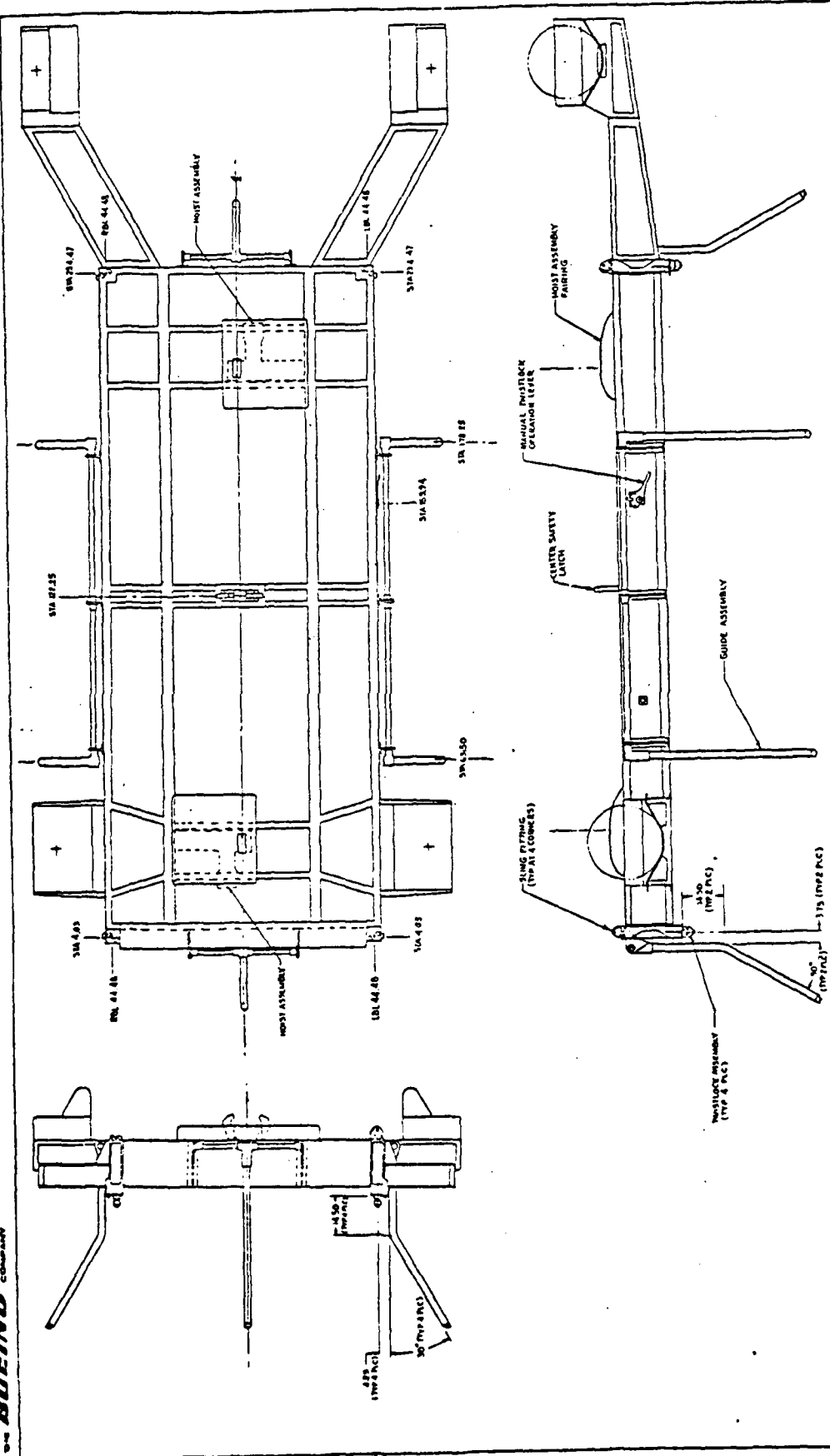

General Arrangement

Figure 1

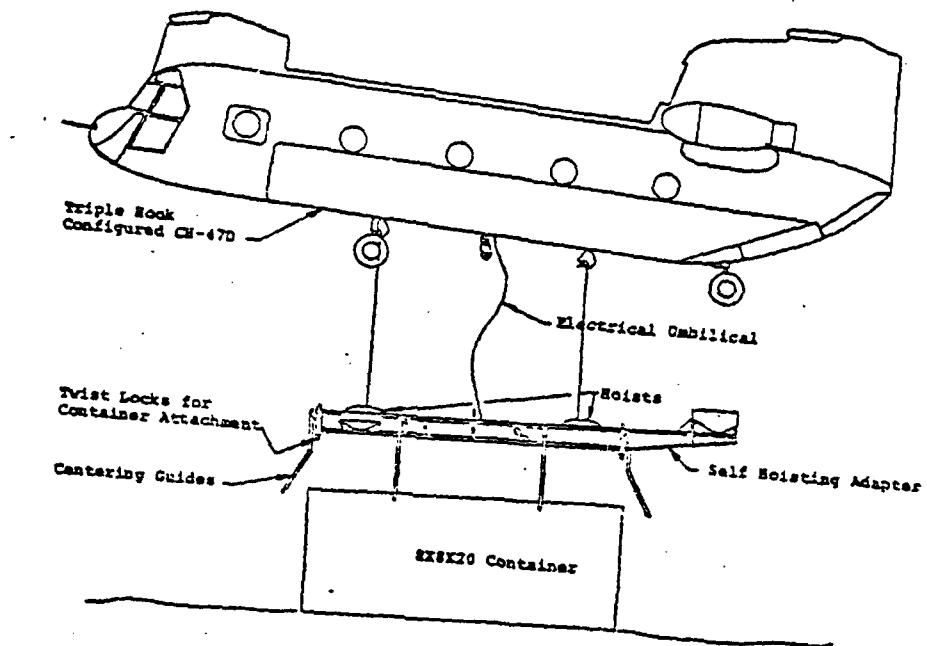

ADAPTER DEPLOYED FOR ACQUISITION

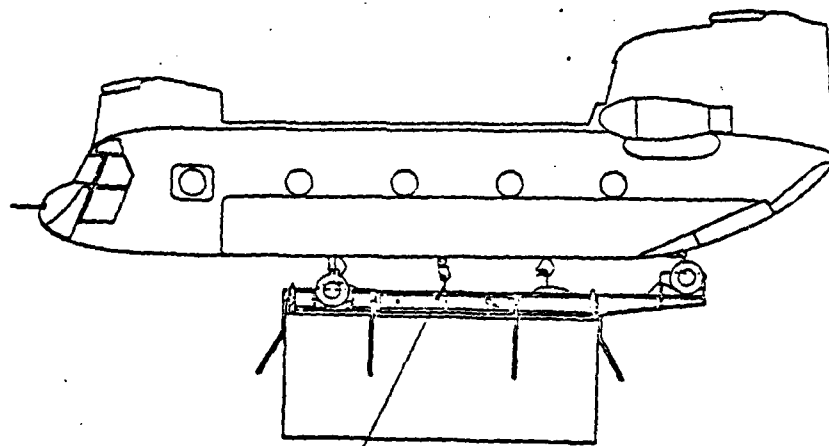

ADAPTER/LOAD INVERTED TO AIRCRAFT

FIGURE 2

THE **BOEING** COMPANYNUMBER D210-11381-1
REV LTR

3.1.1 System Description - Continued

basic structure includes the extensions and pads required to locate and interface the adapter with the aircraft landing gear.

2. A twistlock system that will engage with the ISO container. The twistlocks are actuated by a single electrical actuator, with mechanical interconnection. A manual lever will provide an override capability for backup ground use, or when electrical power is not available.
3. Guide assemblies are located to provide one guide arm at each end of the container and two guide arms at each side. The guide arms are readily removable for replacement, or to allow loads to be positioned in restricted areas.
4. Two hoists shall be arranged at locations to suit the tandem hook spacing on the CH-47D. The hoists are to be powered from the aircraft's electrical system by means of an umbilical cord. The hoists are mounted with dynamic isolators to prevent amplification of the airframe vibration degrading the aircrew environment.

The ECHS system will nominally operate as follows:

The ECHS is positioned in a clear area, supported by the six guide arms. The hoist cables are fully out. (This would be the normal final configuration on completing an operation. If the cables have been rewound on the drums for storage, a ground power unit may be used to provide power to deploy the cables prior to use.) The ECHS may also be positioned alongside the CH-47D helicopter and the umbilical cable connected from the helicopter to the ECHS junction box, providing power to deploy the cables.

The CH-47D helicopter will have a hoist motor speed control unit and ECHS control panel on board. See Figures 3 and 4. The control unit will be connected to the aircraft AC bus. The control panel will be connected to the motor speed control unit and to the cabin DC power outlet, and to the remote pilot override control installed in the cockpit. A pre-coiled umbilical cable is attached to the motor speed control unit via breakaway type quick disconnects. The umbilical cable is located adjacent to the open hatch at the center hook. The center hook would be down, ready for use.

The helicopter will hover approximately 12 feet above the ground, properly aligned over the ECHS. The umbilical cable is passed down through the hatch to a ground crewman stationed on the ECHS, who connects the cable to the junction box on the ECHS structure. The ground crewman will then attach the eye terminal of the forward hoist cable to the forward hook, followed by the aft hoist cable to the aft hook. The ground crewman will descend from the ECHS and clear the area. Alternately, the two hoist cables may be connected to the hooks prior to takeoff, while the aircraft is on the ground beside the adapter; thus eliminating the need for the ground

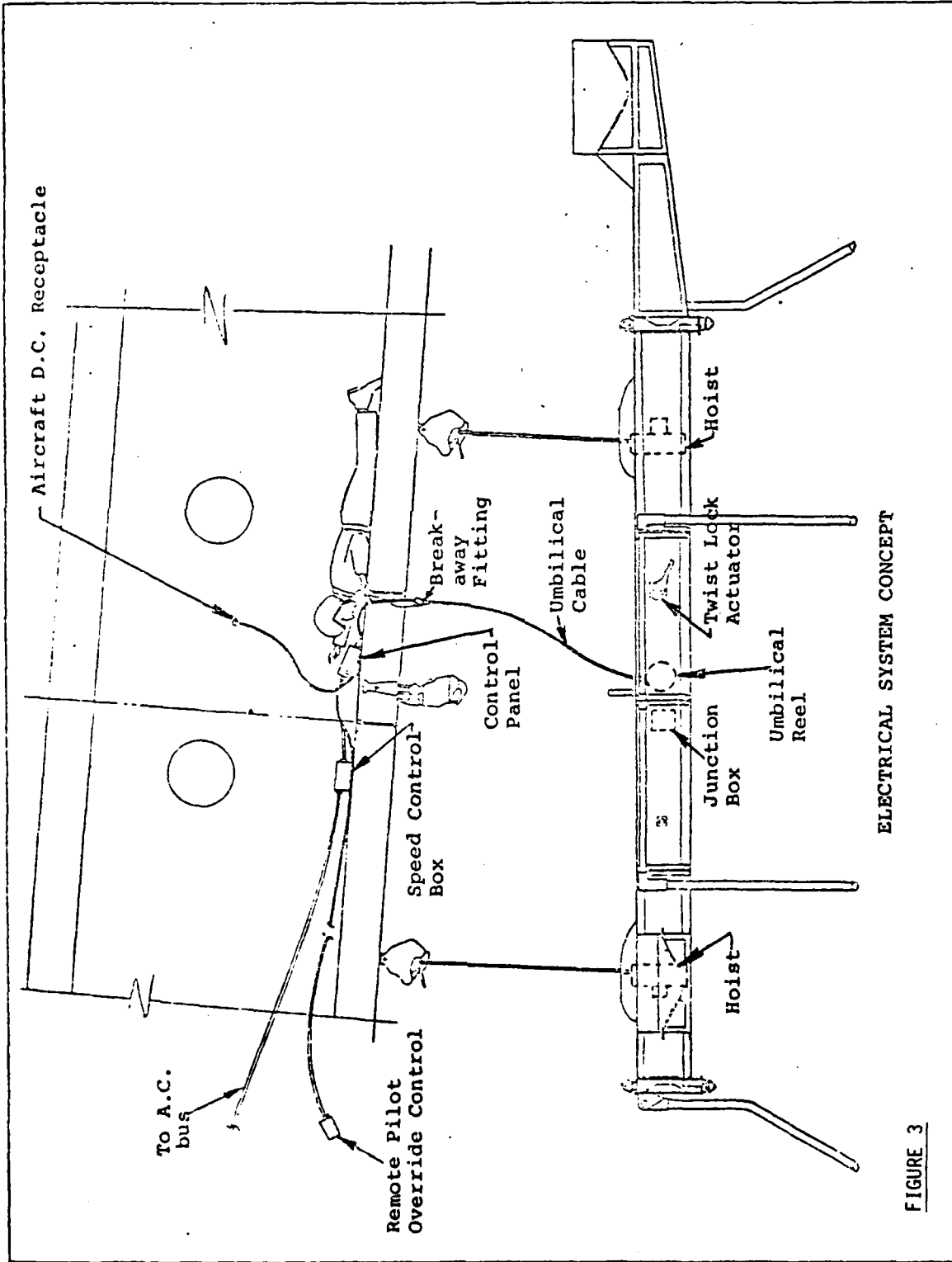

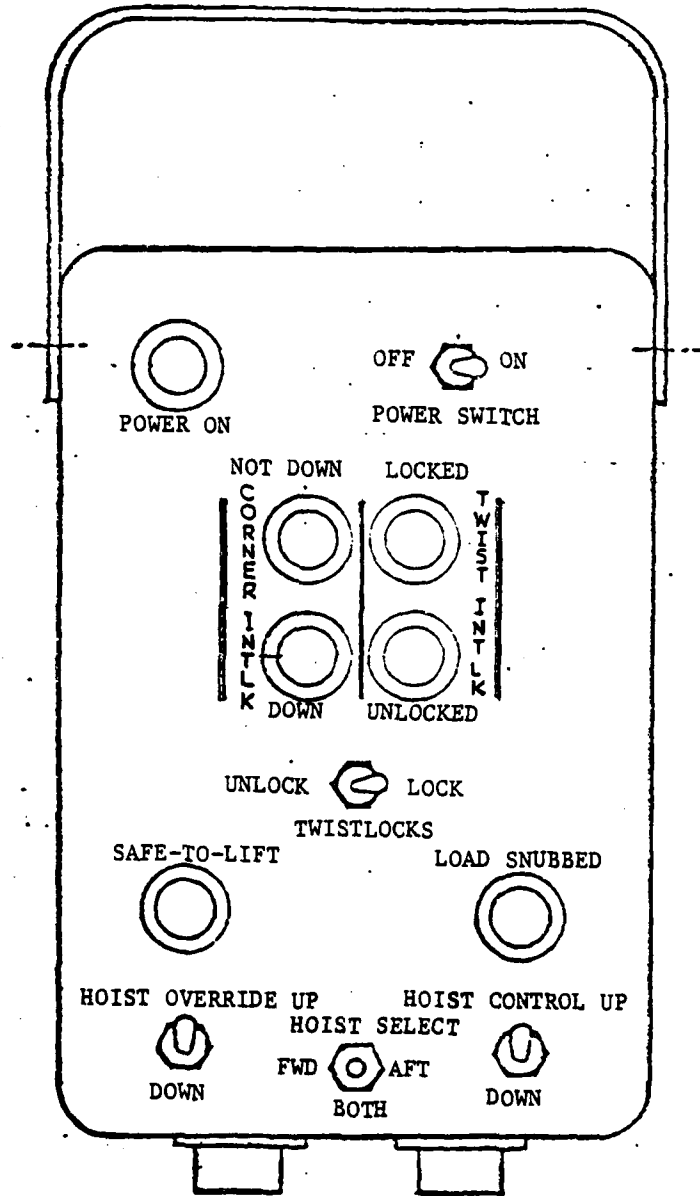

FIGURE 4

CONTROL PANEL

3.1.1 System Description - Continued

crewman from having to stand close beneath the helicopter during hookup.

The helicopter will then lift the ECHS clear off the ground and energize hoist-up control on the control panel until the "safe to lift" indicator is lit on the control panel. The ECHS will now be suspended approximately 10 feet below the helicopter in a level attitude. The helicopter will now be flown to the cargo area and positioned over the container or Gondola to be transported. The helicopter will slowly descend until the ECHS guide arms are located just above the load. Continued descent will allow the twistlocks to center the receptacles on the container, and the weight of the ECHS is supported by the container.

At this time, the corner interlock down indicator will light on the control panel and the twistlock "lock" position can be selected. When the twistlocks are all locked, the "locked" indicator will light on the panel. The helicopter will now ascend, lifting the ECHS and the load clear of the ground. The operator now selects "hoist up" on the panel. The hoist select switch must be in "both" during normal operations. The forward hoist will begin to reel in its cable followed by the aft hoist, thus pulling the ECHS toward the helicopter. As the ECHS approaches the helicopter, the attitude of the ECHS is gradually changed to match the mockup attitude of the aircraft. When the ECHS contacts the landing gear, limit switches will de-energize the hoists and the hoist brake will engage. The limit switches will be adjusted to provide the correct amount of pre-load on the landing gear. The "load snubbed" indicator will now be lit and the hoist control switch can be positioned "off".

The center hook attachment latch will now engage the center hook by means of the latch actuator, sequenced to operate after the hoists are "off". This is a fail-safe attachment and is only loaded if a forward or aft attachment fails. The load is now snubbed to the helicopter and can be flown to its destination.

At the destination, the helicopter will hover approximately 40 feet above the ground and the operator will select "down" on the hoist control. The first action on selecting "down" is for the center hook latch actuator to open the latch. The ECHS will then lower itself from the helicopter until the hoist mounted limit switches prevent further cable payout. The ECHS, with the load, will now be approximately 10 feet below the helicopter in a level attitude. The helicopter now descends to position the container as required on the surface. When the weight of the load is on the ground, the "down" indicator will light on the panel, and the twistlock "unlock" switch position may be selected. When the "unlocked" indicator is lit, the helicopter can ascend. The helicopter then returns for further loads with the ECHS suspended, or while in hover, the ECHS may be raised to snub with the landing gear for greater speed capability.

3.1.1 System Description - Continued

To refuel the helicopter without detaching the ECHS, the unload ECHS may be lowered beyond the normal down position by selecting "override down" on the panel. This will permit the ECHS to be suspended approximately 20 feet below the helicopter, allowing the ECHS to be lowered to the ground and the helicopter to land alongside. An interlock feature will prevent the ECHS lifting a load when the cables are in the extended configuration.

On completion of a mission requiring the ECHS, the system would be removed from the aircraft by disconnecting the umbilical cable at the ECHS junction box and then opening the hooks to release the cables. The load and the ECHS may be jettisoned in flight by operating the standard aircraft hook emergency release switch in the cockpit. All three hooks will open and the ECHS complete with load will fall away from the aircraft, disconnecting the breakaway fittings of the umbilical cable.

3.1.1.1 ECHS Structural Arrangement

The ECHS structural arrangement is shown on Figure 5. The structure will be conventional aluminum alloy sheet and extrusion construction for the demonstration ECHS. Consideration of advanced forms of structure, such as composite material, shall be given prior to a production commitment. The basic structure will consist of two longitudinal box beams, each approximately 22 inches wide by 16 inches deep extending between the forward and aft pairs of twistlock housings. Each box structure will have extended angle section longerons at each corner, extending the full length of the structure. Aluminum alloy sheet skins will be assembled to the inside face of the angles to allow all frames and stiffeners to be mounted flush on the inside surface. Sheet metal frames are located where necessary to support equipment or provide load paths. These frames will have extruded aluminum caps or integral flange as necessary for the loads to be carried.

Lateral beams join the two box sections at the twistlock locations, hoist locations, and at the center hook attachment latch. A light weight, integrally stiffened fiberglass panel seals off the top surface between the two box sections.

The basic structure will have lateral extensions at the forward end. These extensions mount the forward landing gear snubbing pads. The frame between the twistlock fitting will be continuous, closing off the rectangular box structures. The aft end of the box will have extensions that extend laterally and rearward, to mount the two aft landing gear snubbing pads. The aft extensions are constructed in a similar manner to the box sections.

The design will provide bolted joints for the four landing gear snubbing pads, allowing these extensions to be removed for storage and transit. Extension of each twistlock housing above the upper surface of the ECHS provide lifting points for using conventional slings to suspend the device when not used in the snubbed mode.

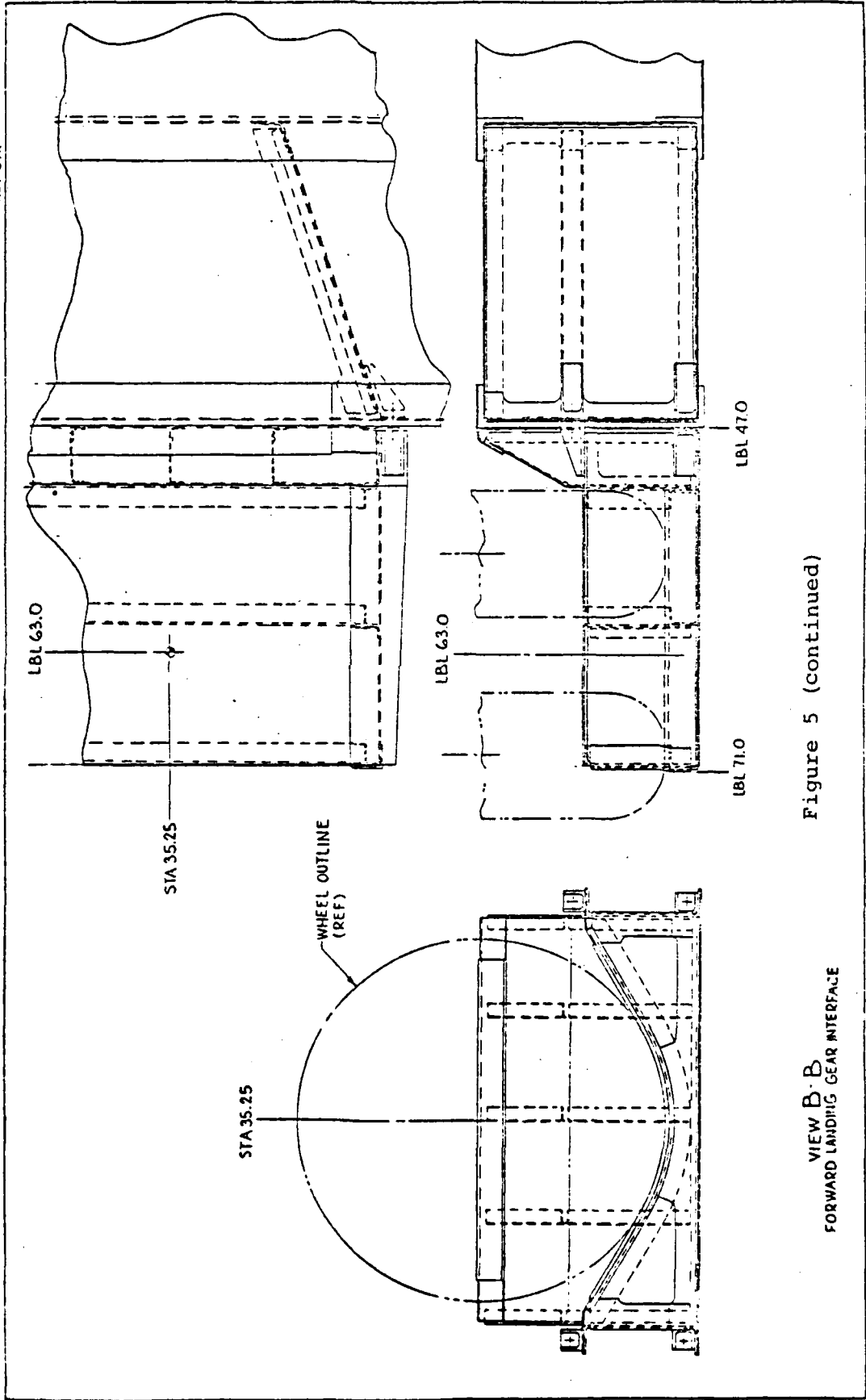

Figure 5 (continued)

VIEW B-B
FORWARD LANDING GEAR INTERFACE

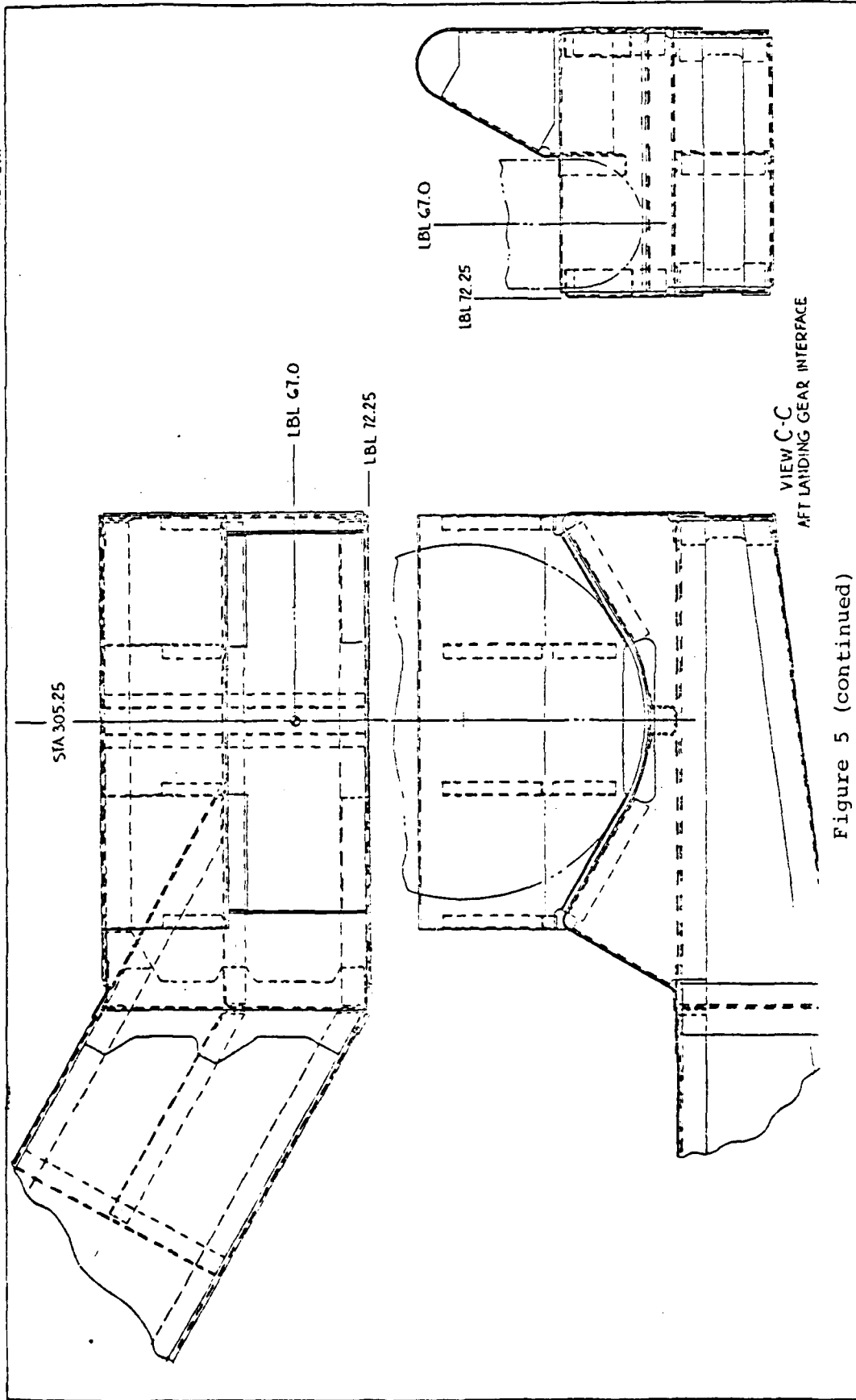

Figure 5 (continued)

3.1.1.1 ECHS Structural Arrangement - Continued

These points are used for ground handling or as a backup lifting means whereby with the use of slings currently in the Army inventory the ECHS and load can be suspended and transported should failure of either hoist prevent normal snubbed operation.

When the landing gear pad extensions are removed, all basic structure shall be within the 8 foot x 20 foot plan form area of the container.

3.1.1.2 Twistlock System

The four twistlock housings are located to match the requirements of ISO 20 foot containers as detailed in specification ANSI MH5.4-1972. These locations are also common to MILVANS and the proposed Army Gondola family. The twistlock housings incorporate support bearings for the twistlocks and provisions for mounting indicator switches for the locked and unlocked positions, and the plunger and switch for the "down" indicators. The twistlock has a cam and sprocket attached to the upper shaft; the cam to actuate the "locked" or "unlocked" switches and the sprocket to accept the drive chain that extends from a countershaft mounted within the basic box structure. Each countershaft has a bellcrank lever mounted within the box structure with an interconnecting push-pull rod arrangement. Figure 6 illustrates the system. The twistlocks are operated by a single rotary actuator which is mounted on a manually rotatable flange normally locked in position. Removal of a locking pin permits the actuator and hence the twistlock system to be operated by a hand lever on the outside surface of the box, providing a manual lock or unlock capability to back-up the electrical system. The system will be designed to prevent operation when the ECHS is carrying a load. Emergency in-flight jettison is accomplished by opening the three aircraft hooks.

3.1.1.3 Guide System

In order to center the ECHS on the container and correctly position the four twistlocks for insertion into the container receptacles, guides are installed along the sides and ends of the ECHS. Six guides are required, two along each of the long sides, and one at either end. The guides shall be located and shaped as shown on Figure 7. Each guide shall be fabricated from tubing and be designed as a spring system to absorb the loads due to impact during normal acquisition. The guides shall be designed for easy installation and removal, and all guides shall be interchangeable.

3.1.1.4 Hoist System

The ECHS will have two identical hoist assemblies, the hoists being located to match the forward and aft hook locations of the CH-47D helicopter. Each hoist shall have a minimum 12 feet of usable cable with 3 1/2 dead wraps on the drum at design load, and shall have the capability of reeling out a total of 22 feet of cable with a minimum of 1 1/2 dead wraps with no load on the ECHS. The demonstration ECHS may use cable developed for the Heavy Lift Helicopter (HLH) program and described in report USAAMRDL-TR-74-97A. This cat.

17-A088 057

BOEING VERTOL CO PHILADELPHIA PA
DESIGN AND ANALYSIS OF CH-47 EXTERNAL CARGO HANDLING SYSTEM (SN--ETC(U)
OCT 79 T S GARNETT, R F CAMPBELL, D J HODDER DAAJ02-77-C-0069
D210-11555-1

F/8 1/3

UNCLASSIFIED

NL

3 of 5

20
2000000

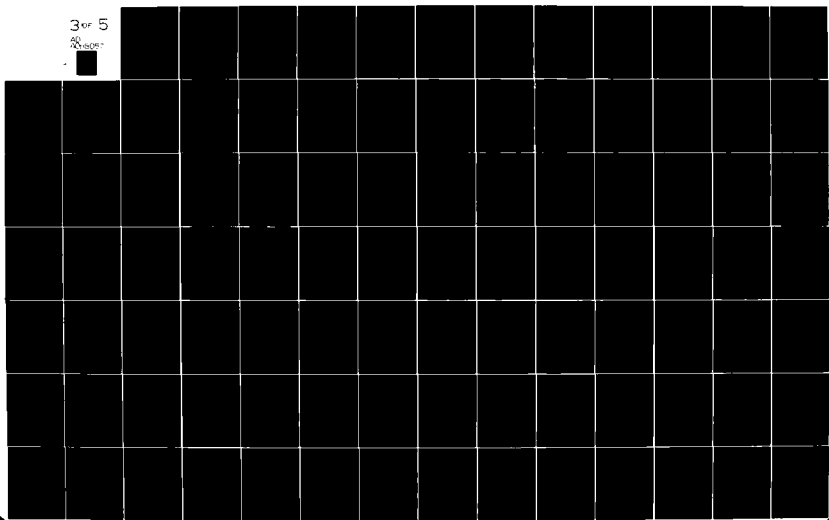

NUMBER
REV LTR

THE **BOEING** COMPANY

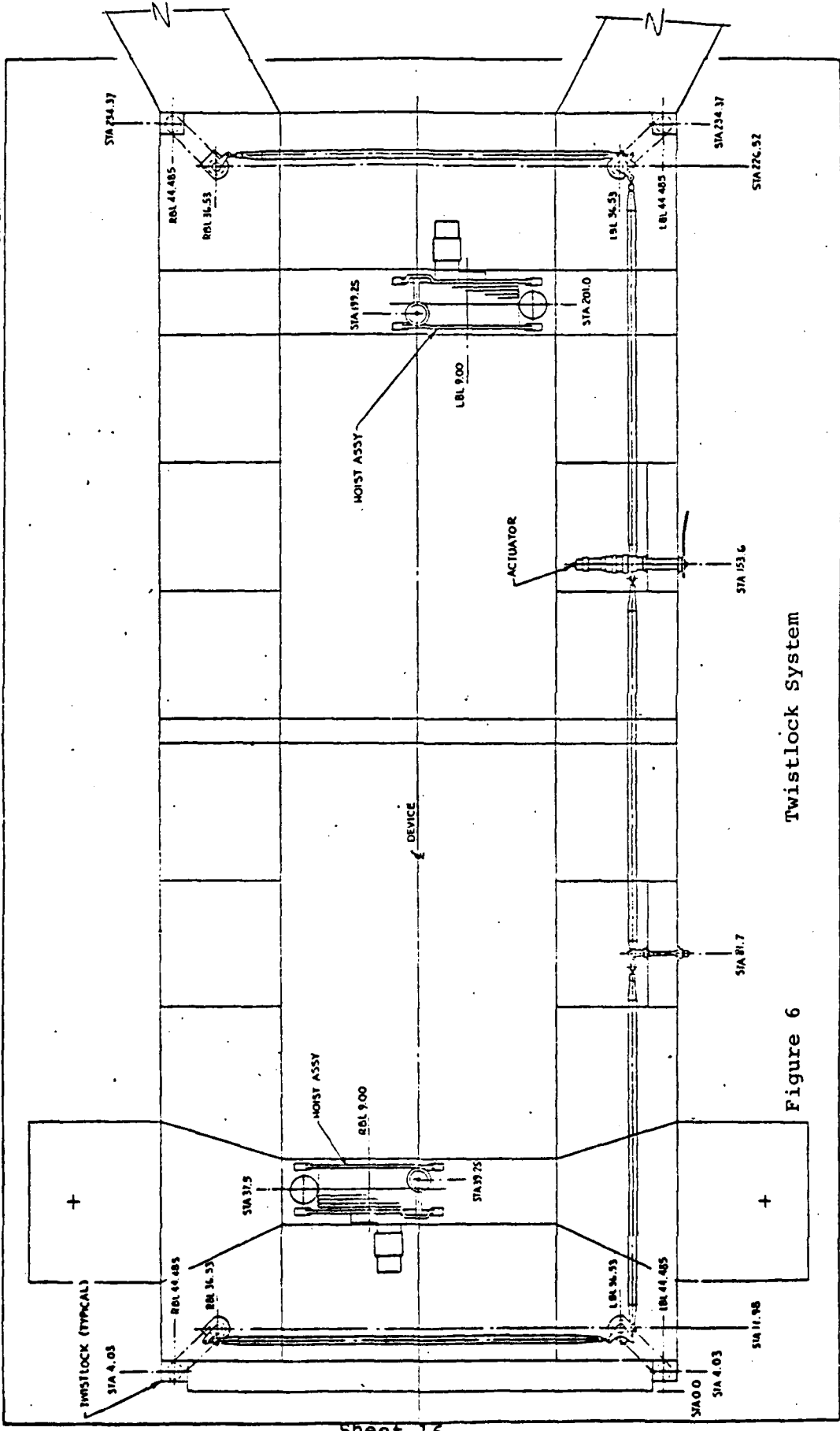
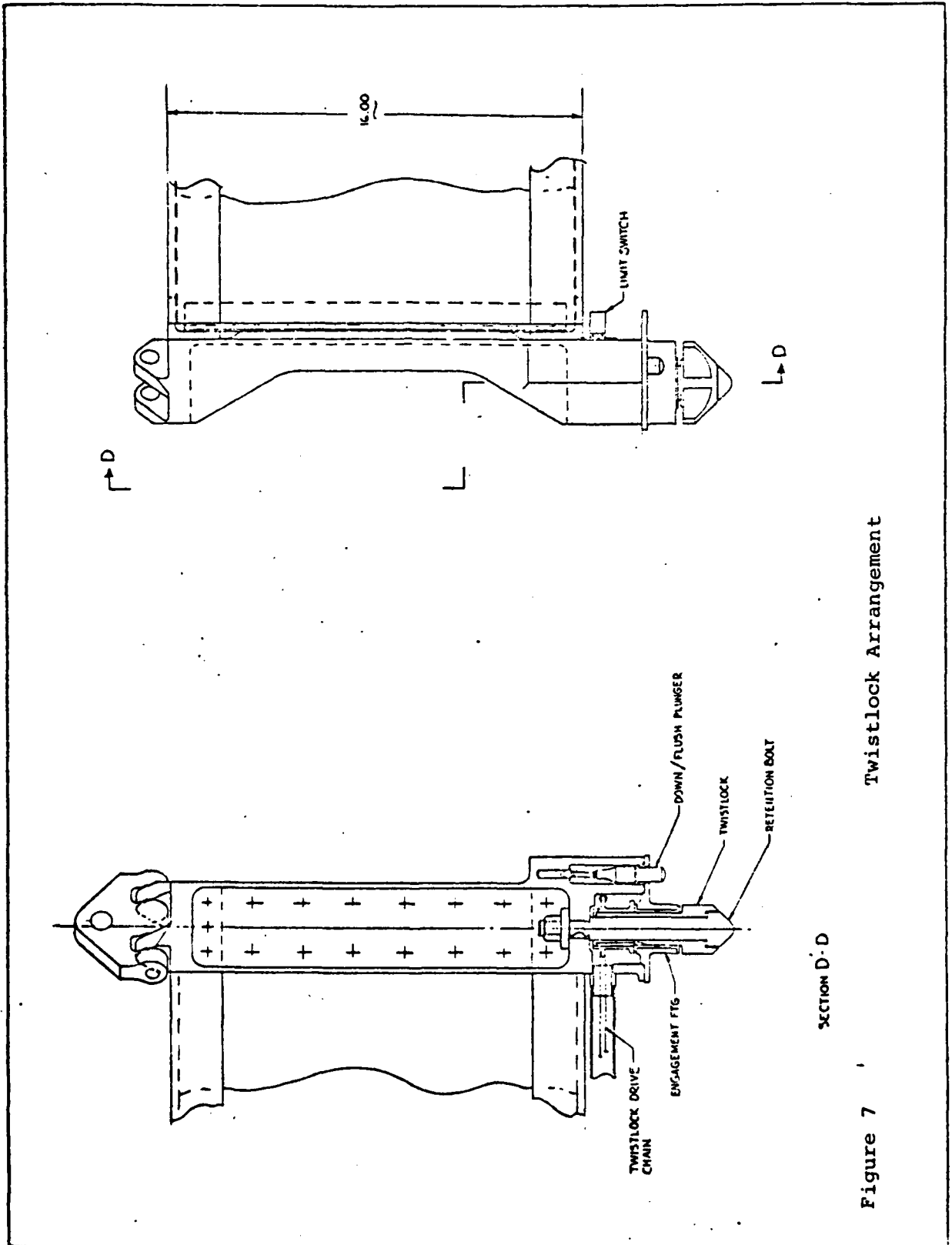

Figure 6
Twistlock System

FORM 2000 11/70



Twistlock Arrangement

SECTION D-D

Figure 7

3.1.1.4 Hoist System (continued)

is .700 diameter, 36 X 7 construction, with a breaking strength of 75,000 pounds. The hoist shall be electrically powered and include an integral holding brake to retain the load with power off. The hoist gearing shall provide a minimum hoisting speed of 10 FPM, and the efficiency shall be such that each hoist will not require more than 6 HP input at maximum load.

The hoist shall have mounting provisions that will interface with an isolator unit. Figure 8 shows an installation arrangement. The load isolator is required to maintain the natural frequency of the suspended load close to 8 Hz for all loads. The non-linear isolator spring shown in Figure 8 has a progressively reducing coil pitch, which varies the spring rate with increasing load (as its coils close and become ineffective).

3.1.1.5 Electrical System

The ECHS will require a junction box on the basic structure with a receptacle for the umbilical cables, containing power wiring for the hoist motors and twistlock motor. In addition, control and signal wiring will be required to the twistlock position switches, down and flush switches and hoist motor limit switches. A portable hoist speed control unit and control panel will be required inside the helicopter, with connecting wiring to the AC bus and DC outlets. The umbilical cable shall be preformed as a coil and attached to the control unit through breakaway fittings.

An alternative arrangement is to provide a spring powered storage reel for the umbilical cable on the ECHS structure. The reel in torque shall be well below the force required to separate the breakaway fittings.

An override control will be installed in an extension cable from the control panel allowing emergency operation from the cockpit.

AC power will be taken from the two AC distribution panels in the cockpit of the CH-47D helicopter. DC power is available at an outlet in the CH-47D cabin at approximately Sta. 350. The control box shall have indicators and controls as shown on Figure 4. The umbilical cable may be arranged as two cables, suitably coupled, to permit the flexibility required to accept the maximum 22 foot movement.

3.2 Characteristics

3.2.1 Performance

3.2.1.1 Structural Criteria

The ECHS shall be capable of supporting and hoisting a maximum load of 25,000 pounds. This load includes the weight of the container and the weight of the ECHS.

The maximum CG offset shall be + 10% of the load length longitudi-

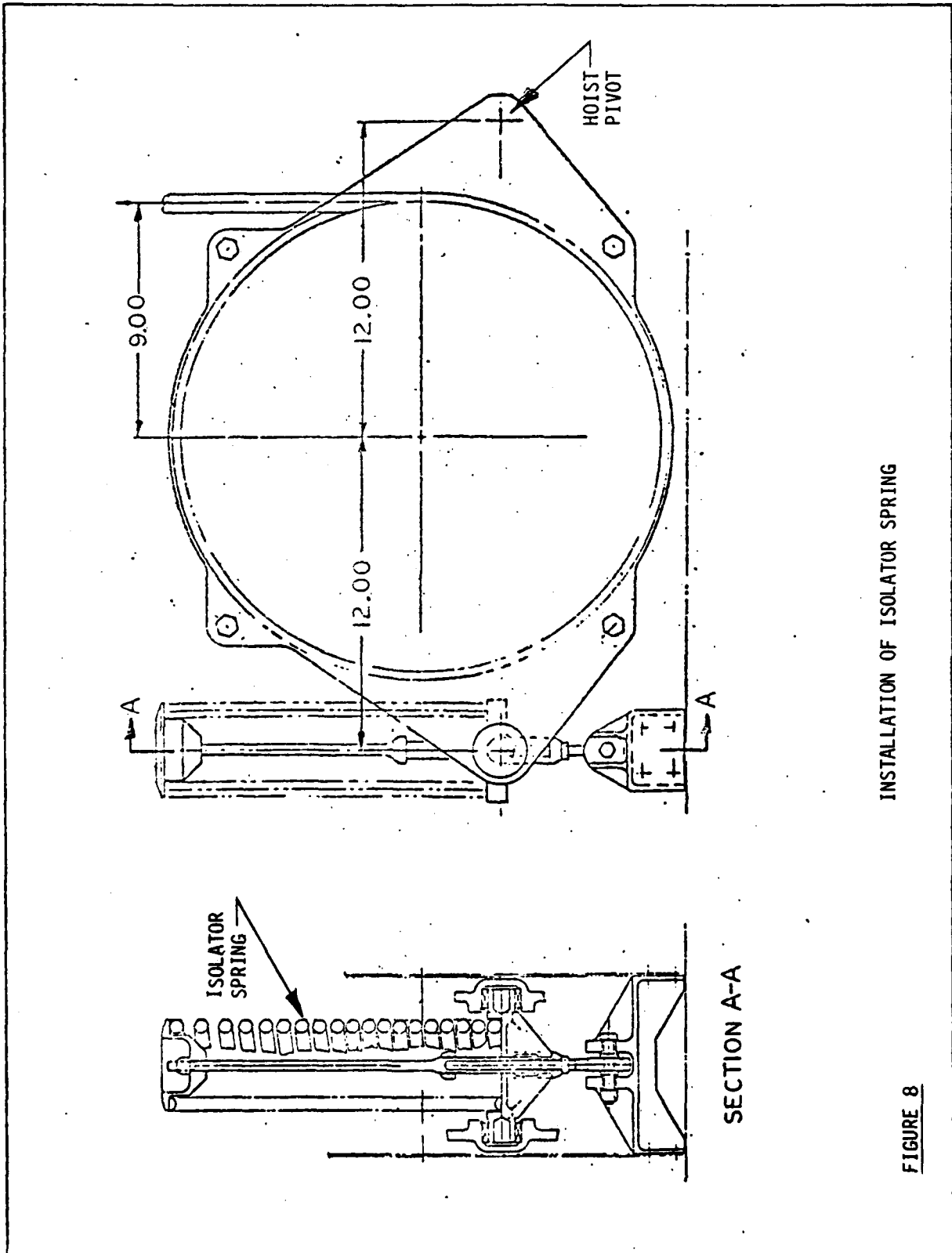

INSTALLATION OF ISOLATOR SPRING

FIGURE 8

3.2.1.1 Structural Criteria (continued)

nally and $\pm 10\%$ of the load width laterally. For an 8 X 8 X 20 foot container or Gondola the CG offset will be ± 2 feet longitudinally and ± 9.6 inches laterally.

The limit load factor shall be a function of the aircraft maneuver. These factors are shown in Table I.

The pre-load to snub the ECHS to the landing gear shall be a total of 5000 pounds (1250 pounds per gear). This pre-load may vary $\pm 20\%$.

The ECHS shall be designed to be normally supported by the two hoist cables attached to the forward and aft tandem hooks of the CH-47D helicopter. Under these conditions, the ultimate load factor shall be 1.5.

The design shall have a redundant link from the ECHS to the center hook of the CH-47D. This link shall normally be unloaded, however, in the event of a failure of the forward or aft attachments, the center link shall be capable of supporting the load. Under this condition, the ultimate load factor shall be 1.0.

Figure 9 shows an arrangement of over-center latch powered by an electrical actuator that would provide a redundant link to the center hook. The latch actuator shall be sequenced in the electrical system to ensure the latch is open before deploying the ECHS, and closed after snubbing is complete.

The preceding criteria result in ultimate loads on the ECHS as shown in Table II. The basic structure shall include backup lifting provisions above the four twistlock housing, such that the ECHS may be suspended and transported with a load at design weight using two, two legged slings, with sling angles not to exceed 30° from the vertical.

3.2.1.2 Hoist Criteria

Each hoist shall be capable of operating at the maximum design load resulting from the most adverse CG condition. With a 160 inch hoist separation and a 24 inch CG offset, the 25,000 pound design load will result in a maximum hoist design load of 16,250 pounds.

The hoist shall operate at a minimum speed of 10 feet per minute at 80% of design load (13,000 pounds).

The hoist shall be capable of operating at an inertia factor of 1.2 times the maximum design load. $1.2 \times 16,250 = 19,500$ pounds.

The hoist shall be designed to operate at the 19,500 pound load within a 15° cone angle from the vertical.

The hoist overrun under any load condition shall not exceed 0.5 inch cable travel.

TABLE I

DESIGN CONDITIONS

CONDITION DESCRIPTION	COND. NO.	ROTOR	ROTOR TORQUE Mz % TOTAL	ROTOR THRUST FzF RzR	LIMIT LOAD FACTOR AT C.G.	ULT. FACTOR	ROTOR LOADS			THRUST POSITION TO DEVELOP HUB MOMENTS
							IN % OF DRAG	FX	FY	
SYMMETRICAL DIVE AND PULLOUT ZERO PITCHING	1	FWD	-50	nwb/c	2.0	1.5	0	0	CENTERLINE OF ROTATION	
		AFT	50	nwa/c			0	0		
SYMMETRICAL DIVE AND PULLOUT NOSE UP PITCH	2	FWD	-50	$1.2nw^2b/c$	1.5	1.5	25	0	FORWARD HORIZONTAL	
		AFT	50	$nw-FzF$			25	0		
SYMMETRICAL DIVE AND PULLOUT NOSE DOWN PITCH	3	FWD	-50	$nw-FzR$	1.5	1.5	-14	0	AFT HORIZONTAL PIN	
		AFT	50	$1.2nw^2a/c$			-14	0		
RECOVERY FROM ROLLING PULLOUT LEFT OR RIGHT	4	FWD	-50	$nw-FzR$	1.2	1.5	-14	± 14	$\pm 45^\circ$ FROM AFT HORIZONTAL PIN	
		AFT	50	$1.2nw^2a/c$			-14	± 14		
ONE LIFT POINT FAILED SYMMETRICAL DIVE AND PULLOUT-ZERO PITCH	5	FWD	-50	nwb/c	2.0	1.0	0	0	CENTERLINE OF ROTATION	
		AFT	50	nwa/c			0	0		

LIFTING POINTS INTACT

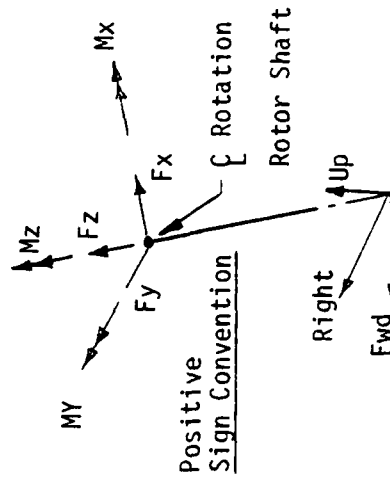

Positive Sign Convention

n = NORMAL LIMIT LOAD FACTOR AT C.G.

w = AIRCRAFT GROSS WT. - 50,000 LB

a = DISTANCE FWD ROTOR TO C.G.

b = DISTANCE AFT ROTOR TO C.G.

c = DISTANCE FWD ROTOR TO AFT ROTOR

DISTANCE CENTERLINE ROTATION TO HORIZONTAL PIN = 8.15"

LIMIT FACTOR ON ROTOR TORQUE = 1.4, ALL CONDITIONS

Sta. 331.0 (ACFT)
WL 36.0 (ACFT)

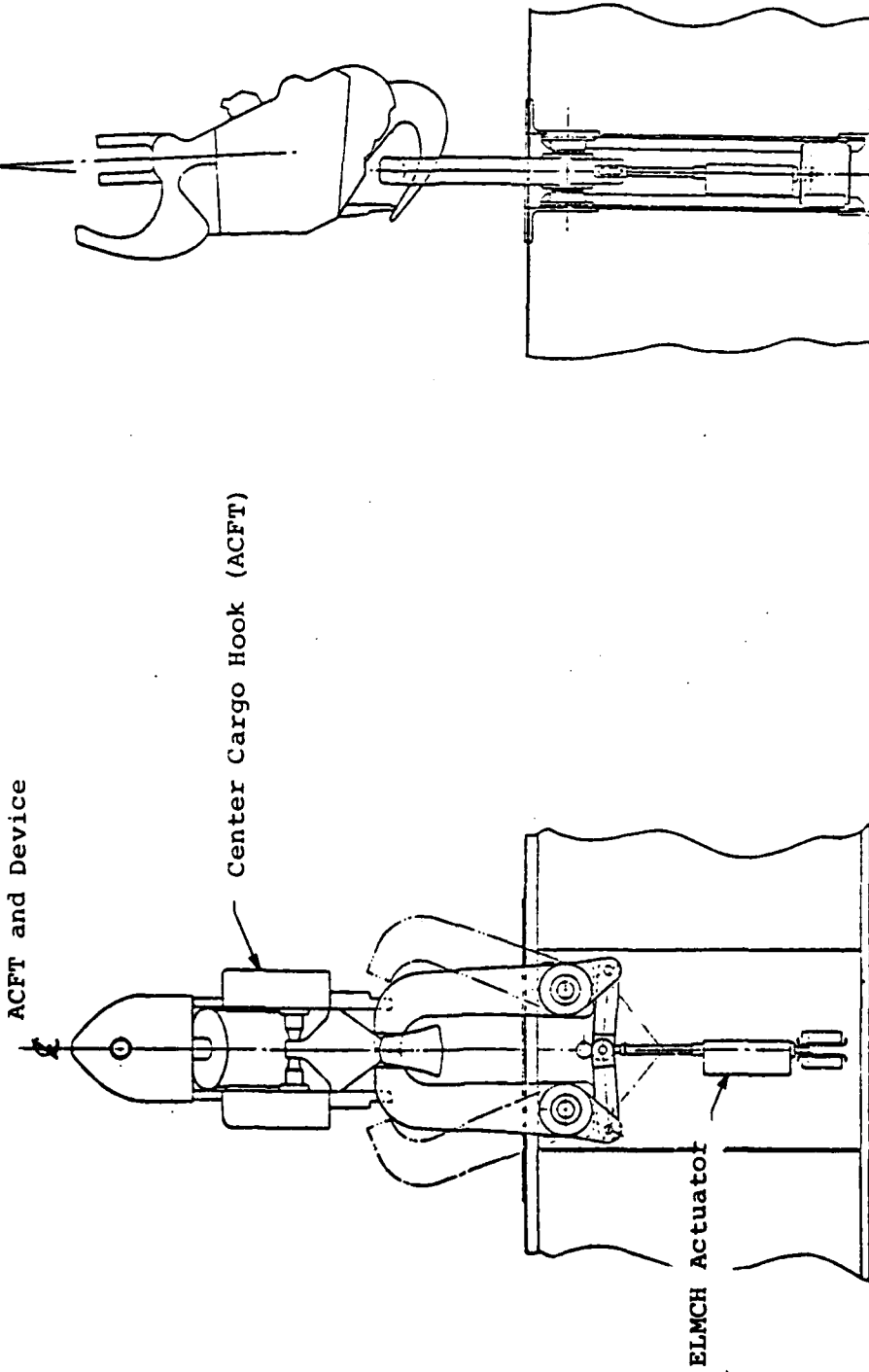
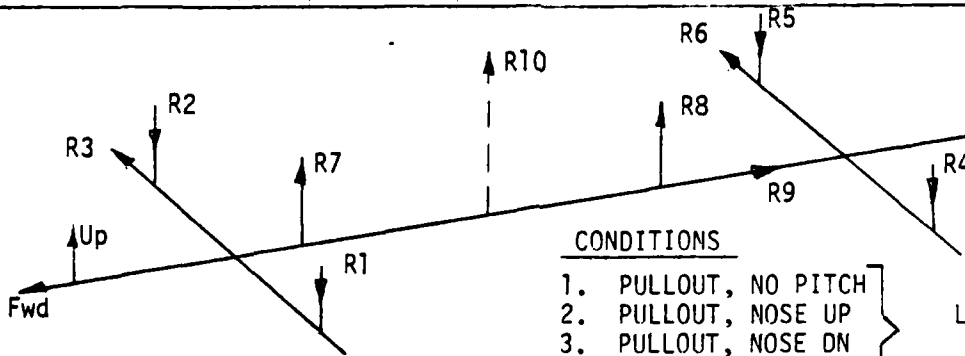

Figure 9 Overcenter Latch

CH-47D SNUBBED EXTERNAL CARGO TABLE II

MAXIMUM REACTIONS

REACTION	MAXIMUM ULTIMATE LOAD (LB.)						TOTAL (ULTIMATE)	
	MANEUVER		GEAR PRE- LOAD	C.G. TRAVEL		AIR LOAD 135 KT		
	COND	LOAD		F & A	LAT.			
R1 FWD. L.H. GEAR	V	4	4331	1875		3672	9878	
R2 FWD. R.H. GEAR	V	4	4331	1875		3672	9878	
R3 FWD. GEAR	LAT	4	+3764				±3764	
R4 AFT. L.H. GEAR	V	4	3515	1875		2981	8371	
R5 AFT R.H. GEAR	V	4	3515	1875		2981	8371	
R6 AFT GEAR	LAT	4	±1276				±1276	
R7 FWD. CABLE	V	1	35484	1360	12329		3723	52896
R8 AFT CABLE	V	1	39516	6140	10172			55828
R9 DRAG PER GEAR		3	1862					1862
R10 CENTER CABLE	V	5	50000		13954			63954



CONDITIONS

1. PULLOUT, NO PITCH
2. PULLOUT, NOSE UP
3. PULLOUT, NOSE DN
4. ROLLING PULLOUT
5. PULLOUT, NO PITCH - ONE LIFT POINT FAILED

LIFTING POINTS
INTACT

POSITIVE LOADS SHOWN
APPLIED TO CARGO

3.2.1.2 Hoist Criteria (continued)

The hoist speed may be lower than 10 feet/minute at loads above 13,000 pounds.

The hoist shall be capable of holding a static load of 40,000 pounds without permanent deformation (limit load).

The hoist shall be capable of holding a 60,000 pound load without failure. The hoist may experience permanent set at this load (ultimate load).

The hoist drum shall be suitable for a cable of 60,000 pound minimum breaking strength. The drum mean diameter shall not be less than 18.00 inches. For minimum drum size, consideration shall be given to the cable construction developed for the HLH helicopter, described in report USAAMRDL-TR-74-97A. Such a cable would be approximately 0.625 inches diameter. The prototype design shall consider available cables.

The cable length shall result in a usable extension of 12 feet under full load, and a usable extension of 22 feet when unloaded (ECHS weight only). In the latter case, there shall be a minimum of 1.5 dead wraps on the drum.

The free end of the cable shall be formed into a loop using a MacWhyte crescent thimble, No. C-4 or equivalent. This thimble has a 1.5 inside radius loop. The free end shall be swaged through an eye splice sleeve as shown on Figure 10.

The hoist design duty cycle shall be 4 minutes on; 20 minutes off. The 4 minutes on shall consist of raising the maximum design load (16,250 pounds) 10 feet, lowering the load 10 feet, raising the load 10 feet and lowering the load 10 feet.

The hoist shall be powered by an electric motor, suitable for 115/208 VAC, 400 cycles, 3 Ph.

Hoist efficiency shall be such that at 80% of design load and at design speed, the hoist will not require more than 6 HP (4480 watts).

Adjustable limit switches shall ensure that a minimum of 3 1/2 wraps of cable remain on the drum when operating under load, and a minimum of 1 1/2 wraps of cable remain when operated without a load.

The hoist attachment to the structure shall provide for the incorporation of a load isolator to the criteria of Section 3.2.1.3. Figure 8 illustrates a suitable arrangement of hoist and isolator.

3.2.1.3 Load Isolators

In order to prevent the interaction of the helicopter vertical and 3 per rev vibration, and the suspended/snubbed load, a load isolator shall be installed at each hoist location. Figure 8 shows a hoist/isolator installation.

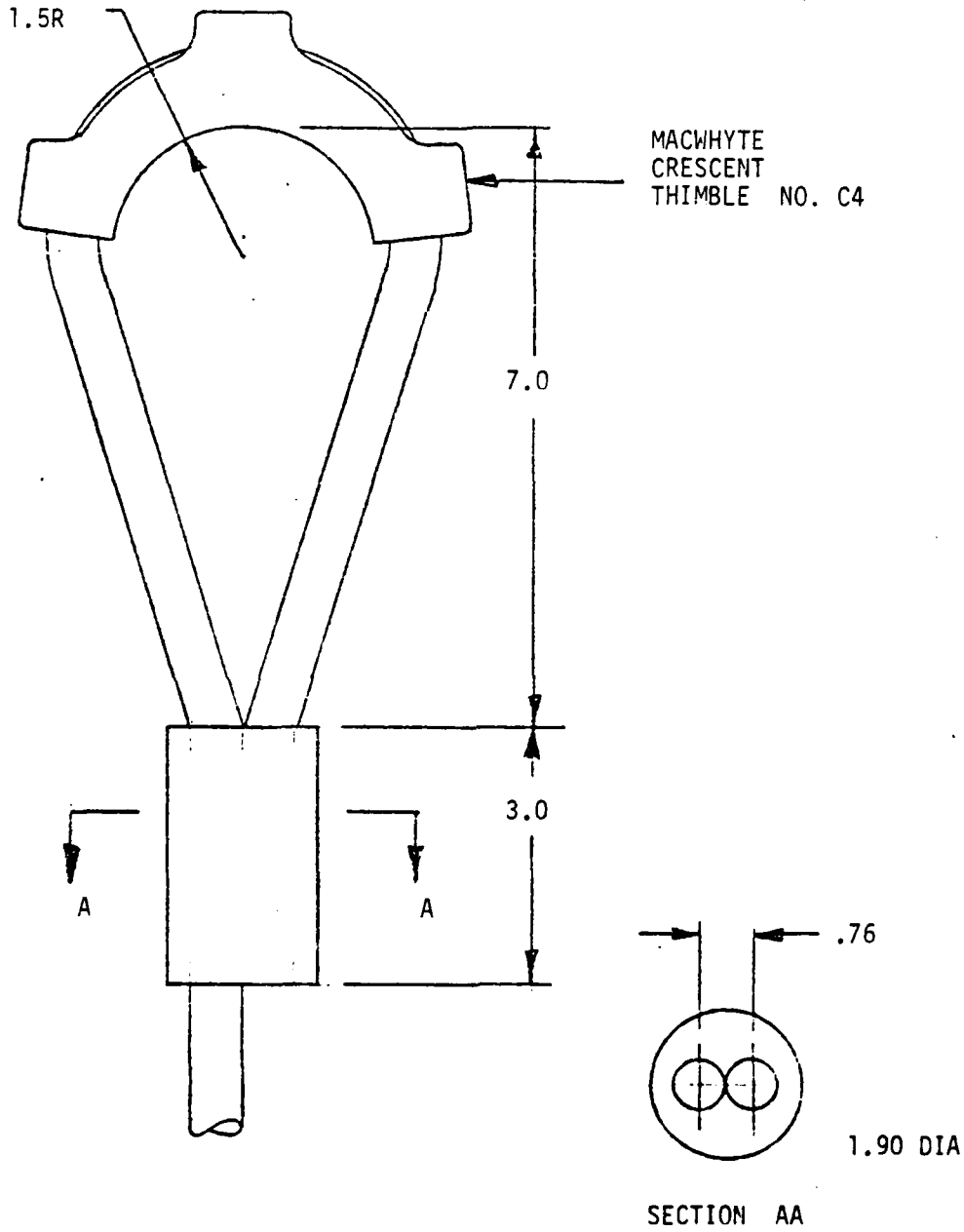

FIGURE 10 **CABLE EYE END**

3.2.1.3 Load Isolators (continued)

The natural frequency of the vertical mode for the snubbed load shall be maintained above 5.25 Hertz to prevent 1 per rev amplification and below 7.9 Hertz to prevent 3 per rev amplification for all loads up to design load.

The desired characteristics of each isolator (at the cable) are shown on Figure 11.

When arranged with a geometry as shown on Figure 12, a practical spring design would provide characteristics approximately as follows:

<u>Suspension System at Cable</u>			<u>Isolator Spring</u>		
<u>LOAD</u>	<u>SPRING RATE</u>	<u>DEFLECTION</u>	<u>LOAD</u>	<u>SPRING RATE</u>	<u>DEFLECTION</u>
1600 LB	13,000 LB/IN	.07 IN	200 LB	200 LB/IN	.55 IN
10,000 LB	200,000 LB/IN	.24 IN	1250 LB	3100 LB/IN	1.93 IN

The Spring Rate/Load and Deflection/Load characteristics of Figure 13 can be obtained from a mechanical spring design as shown in Figure 8. A variable coil pitch provides the isolator characteristics. Preliminary requirements would be as follows:

- .500 diameter CHROM SILICON Wire
- 21 coils
- 3.0 mean diameter
- Initial (free) length 13.02 inch
- First Coil Spacing - .050 inch
- Last Coil Spacing - .389 inch
- Installed Preload Approximately 100 pounds

3.2.1.4 Twistlock System Criteria

The twistlock geometry shall be compatible with the American National Standard Specification for International (ISO) Freight Containers, ANSI ME5.4-1972.

The twistlock system shall operate from locked to unlocked, or from unlocked to locked within one second.

The twistlock actuator shall have a design torque of 250 in-lbs minimum at the design speed above.

The twistlock actuator shall have a minimum stall torque of 500 in-lbs.

The twistlock actuator shall require a 200 VAC

- 400 cycle 3 ph electrical supply

NOTE: Plessy actuator Part No. M422M12 fulfills the above requirements.

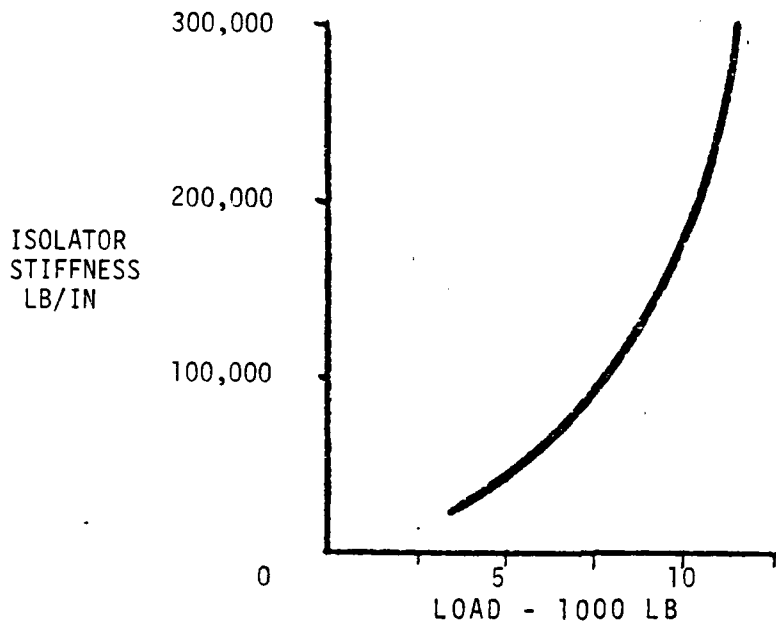

FIGURE 11

ISOLATOR REQUIREMENTS

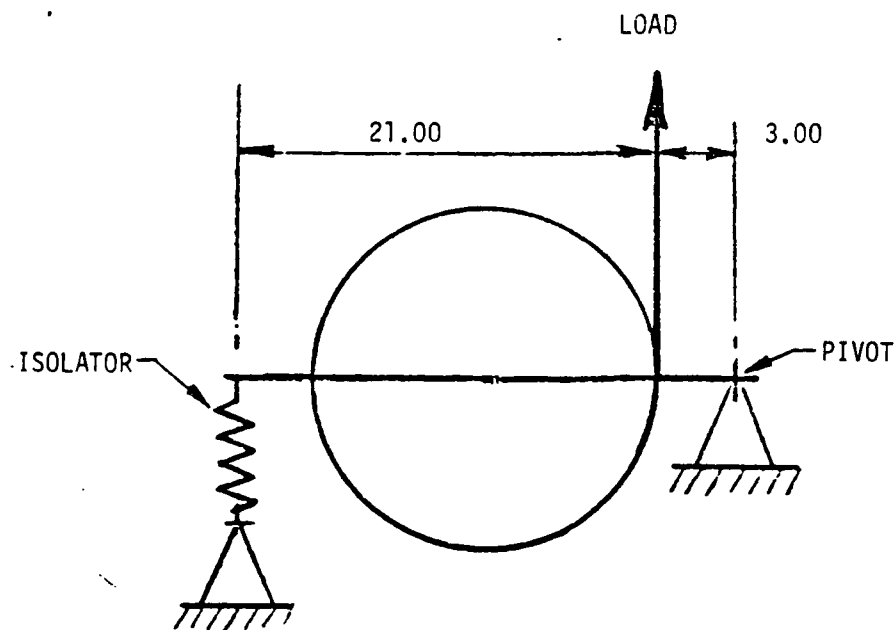

FIGURE 12

ISOLATOR GEOMETRY

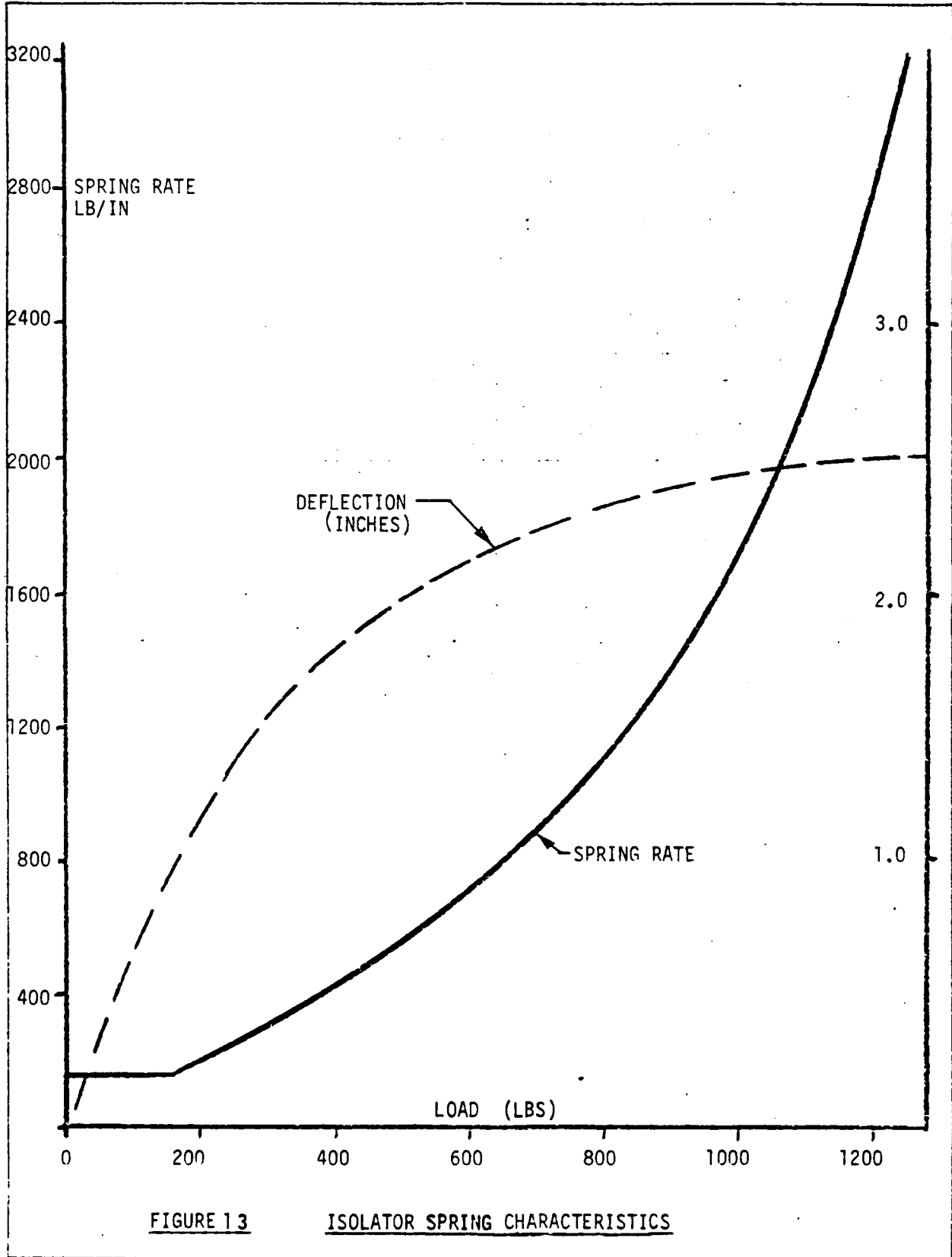

FIGURE 13

ISOLATOR SPRING CHARACTERISTICS

3.2.1.4 Twistlock System Criteria (continued)

- The hand lever shall not require more than 20 pounds effort at the end of the lever to lock or unlock the system.

The twistlock control circuit shall have an electrical interlock such that the actuator cannot operate until the ECHS is correctly positioned onto the load. Figure 14 illustrates a suitable plunger/switch arrangement, typical at all four corners of the ECHS. Twistlock alignment limits shall be as shown in Figure 15.

Each twistlock shall have switches to indicate the position of the twistlock. Figure 16 shows a suitable switch arrangement.

3.2.1.5 Guide System Criteria

The guide shape, length and locations shall be as shown on Figure 1 for the demonstration ECHS.

The guide system shall be considered as a structural spring, storing energy due to any impact, and releasing that energy in returning to a normal position.

The guide shall be designed to accept a minimum strike velocity of 4.0 feet/second in the longitudinal, lateral or vertical direction.

The load at the end of the guide that results from the impact velocity of 4.0 feet/second shall be considered the limit load. Ultimate load shall be 1.5 X limit load.

Guide tube attachments shall be designed for an ultimate load of 2.0 X limit load.

Guides shall be interchangeable and readily replaceable.

3.2.1.6 Control System Criteria

The portable control panel (Figure 4) shall have the following controls and indications:

- Power "on-off" switch
- Power "on" indicator
- Twistlocks "locked-unlocked" switch
- Twistlocks "locked" indicator
- Twistlocks "unlocked" indicator
- Corner interlock "down" indicator
- Corner interlock "not down" indicator
- Hoist select switch - fwd, both, aft (normally "both")
- Hoist control "up-down" switch
- Load snubbed indicator
- Hoist lower override switch
- Hoist "safe-to-lift" indicator

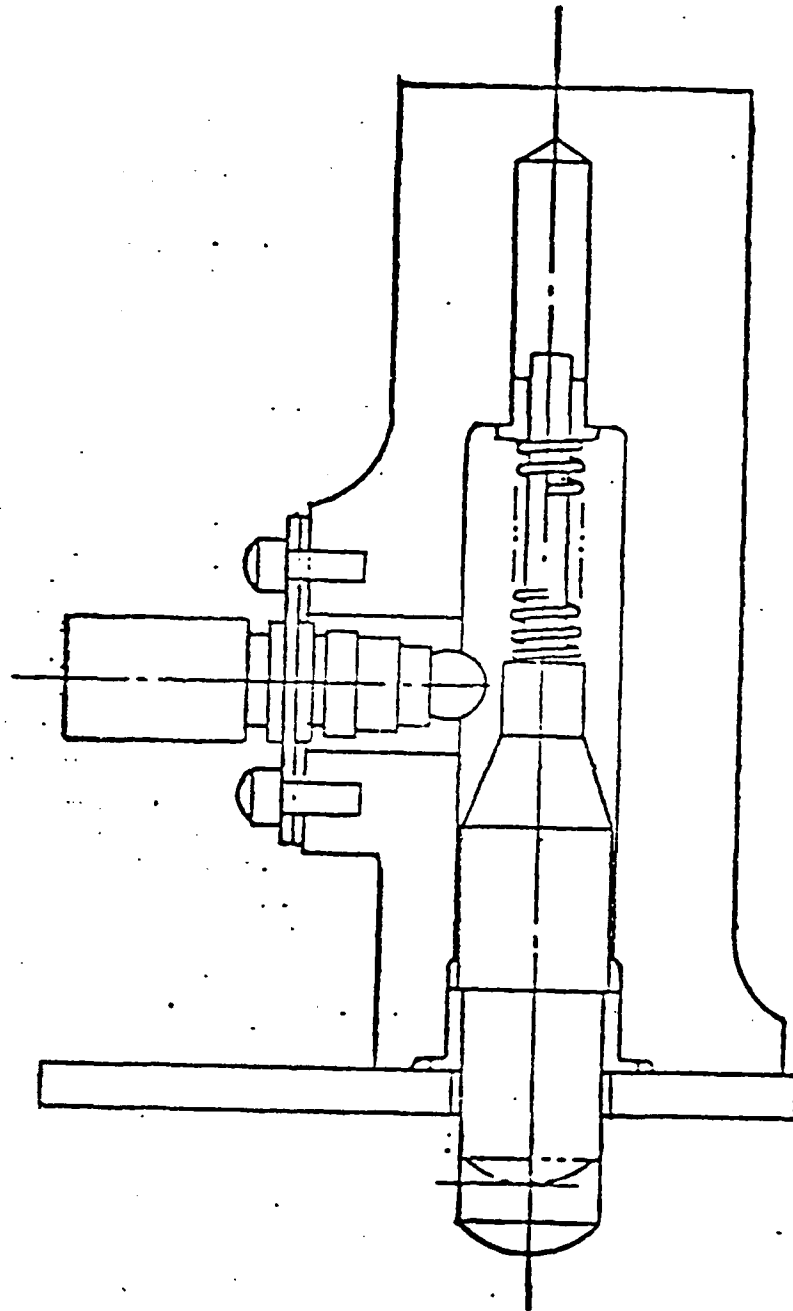

SECTION THROUGH TWISTLOCK HOUSING
TYP. 4 PLACES

FIGURE 14

CORNER INTERLOCK SWITCH

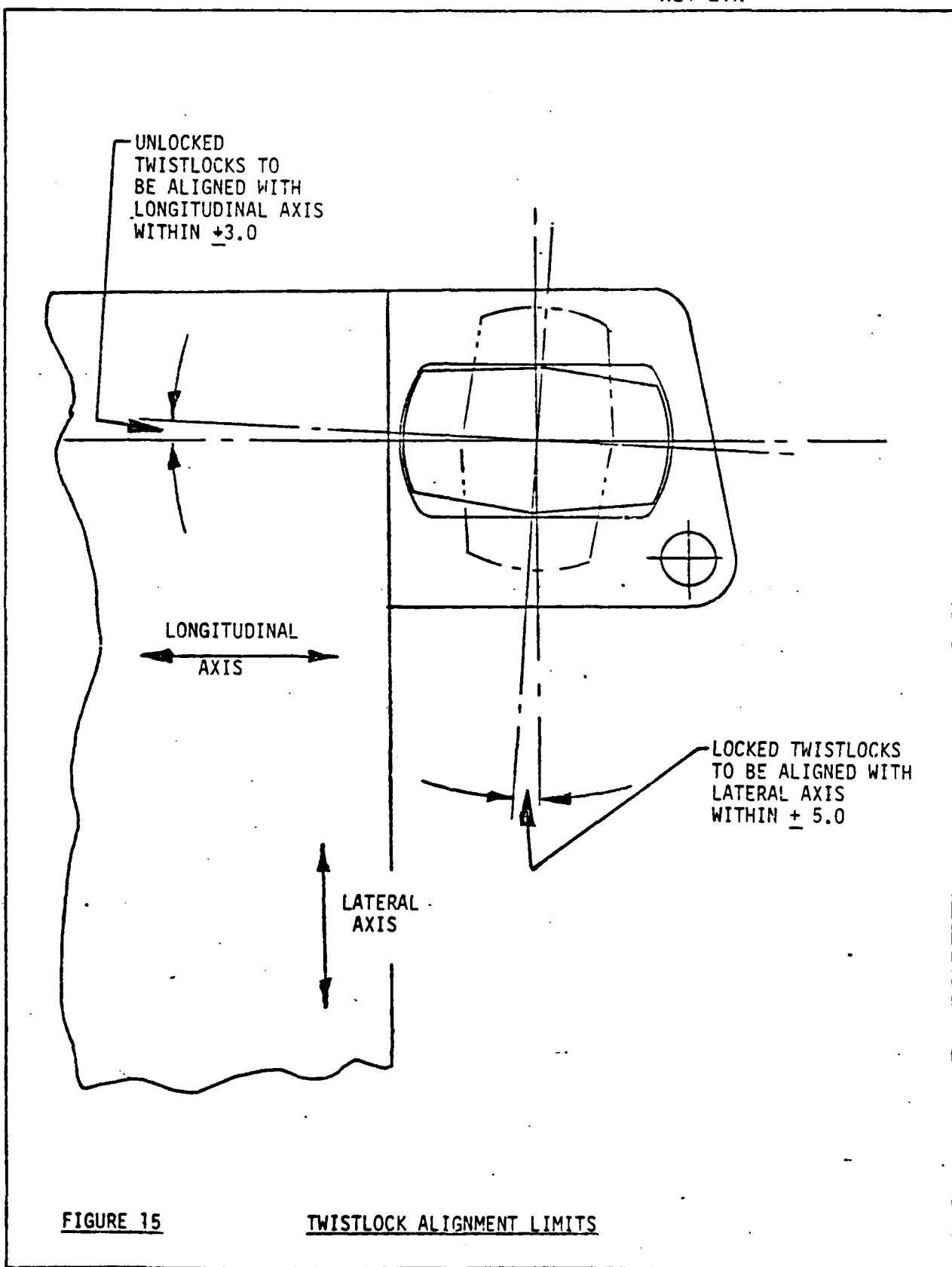
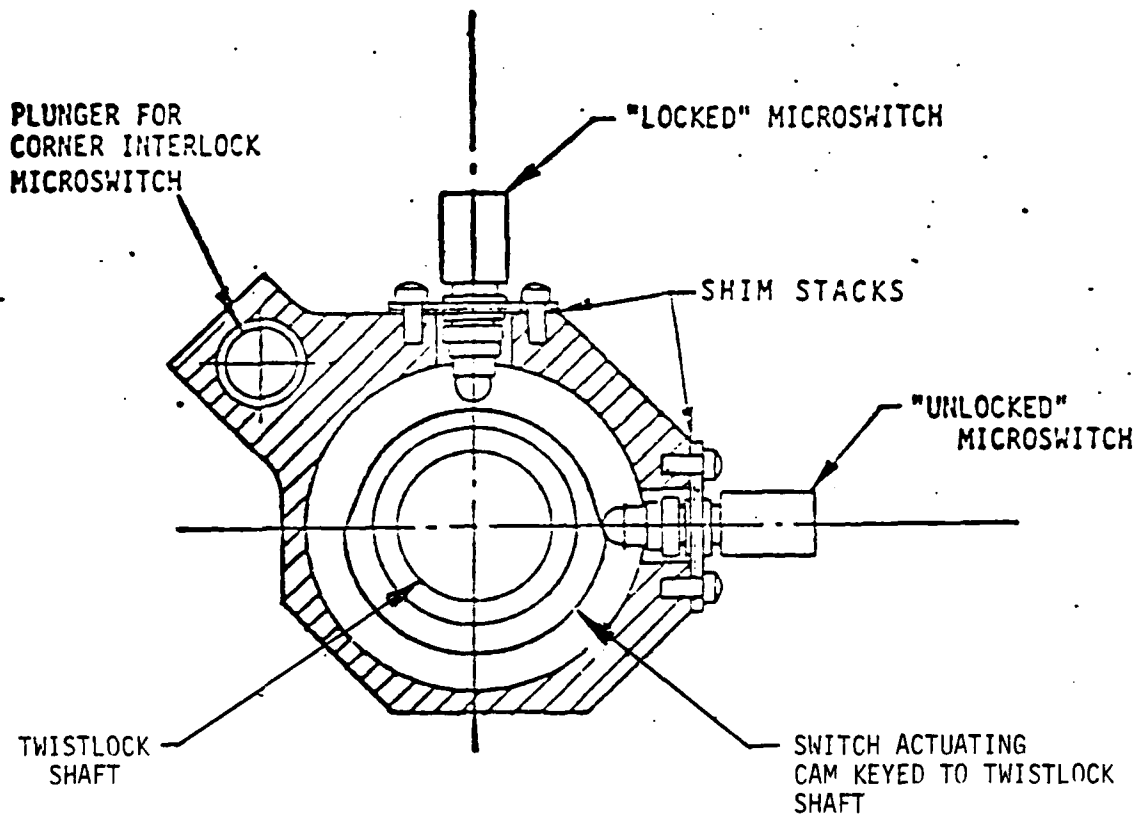

FIGURE 15

TWISTLOCK ALIGNMENT LIMITS

FORM 40284 (2/69)



SECTION THROUGH TWISTLOCK HOUSING

FIGURE 16

TWISTLOCK POSITION INDICATORS

3.2.1.6 Control System Criteria (continued)

Hoist motor control system shall result in a differential speed between the two hoists, such that when fully out (under load) the forward hoist has deployed approximately 19 inches more cable than the aft hoist. This differential will permit the ECHS to be approximately level when the aircraft is in hover, and lined up with the landing gear when raised to the aircraft.

3.2.2 Physical Characteristics

3.2.2.1 Weight

The ECHS shall be designed for a minimum weight consistent with good design, ease of maintenance, high reliability and optimum cost. Weight targets for the various elements of the demonstration system are as follows:

	<u>PROTOTYPE DESIGN POUNDS</u>	<u>PRODUCTION DESIGN POUNDS</u>
Basic Structure	850	640
Snubbing Structure		
Twistlock System	110	95
Guide System	190	95
Hoists (2)	480	400
Cables	60	48
Isolators	33	33
Electrical Hardware	100	100
Miscellaneous	<u>50</u>	<u>50</u>
TOTAL	1873	1461

The electrical hardware target includes the aircraft elements, i.e., hoist speed control unit, control panel and distribution cables.

The basic structure includes all that structure required to interface with the 8 X 8 X 20 foot container. Snubbing structure includes those extension elements attached to the basic structure in order to interface with the landing gear of the CH-47D helicopter.

3.2.2.2 Size

The ECHS shall be sized to be compatible with an 8 X 8 X 20 foot container, MILVAN or Gondola meeting the physical requirements of ANSI MH5.4 1972.

3.2.2.2 Size (continued)

The hoist locations shall be suitable to interface with the forward and aft cargo hook locations of the CH-47D helicopter.

The center attachment device shall be suitable to interface with the center hook of the CH-47D helicopter. Under normal operation, there shall be no load transfer between the center hook and the center attachment device.

The snubbing structure shall be located to be compatible with the CH-47D landing gear. The snubbing structure shall be removable from the basic structure. When the snubbing structure is removed, the basic structure (excluding the guide system) shall not extend beyond an 8 foot X 20 foot platform.

The depth of the ECHS shall be a minimum consistent with protection of the hoist system and obtaining a structure weight within the weight target of Paragraph 3.2.2.1. Consideration should be given to using appropriate fairings over the hoists.

3.2.2.3 Transport and Storage Requirements

The ECHS shall be designed for economical storage. Snubbing extensions and guides shall be readily removable to reduce storage space requirements. Component finish shall permit outside storage without corrosion or deterioration.

3.2.2.4 Durability

The ECHS shall be designed to meet the strength requirements of Paragraph 3.2.1; however, the design shall be such that handling by unskilled personnel shall not result in damage. The minimum gage of external aluminum and skins shall be .036. External stiffeners shall avoid designs with free flanges. The upper surface of the basic structure shall have clearly marked areas for ground crew to stand during service and operation.

3.2.3 Reliability

Reliability requirements for the ECHS are defined herein. No component tests or demonstrations specifically designed for reliability measurements are specified for the development of this system. The reliability quantitative requirements defined herein shall constitute a design objective and shall be demonstrated by current reliability analysis methods.

The following items are applicable to the reliability factor:

- (a) Environmental conditions shall be as defined in 3.2.5.
- (b) Component reliability shall be based on independent failures only.
- (c) Damage due to enemy action shall not be considered.

3.2.3 Reliability (continued)

- (d) Damage due to operation outside prescribed limits shall not be considered.
- (e) All Mean Time Between Failures (MTBF's) are in terms of component hours. ECHS flight hour utilization is assumed to be 50% of aircraft flight hour utilization.

3.2.3.1 Mission Reliability

The ECHS shall have a "mission reliability" MTBF of 500 component hours.

3.2.3.2 System Operational Reliability

The ECHS shall have a "system operational reliability" MTBF of 150 component hours.

3.2.3.3 Mean Time Between Unscheduled Removals (MTBUR)

The ECHS shall have a design objective of "on condition" operation, with a mean time between unscheduled removal (MTBUR) of 300 component hours. This means that the system, or its major elements, shall not require unscheduled removal more than once per 300 component hours, on the average, for repair, or inspection.

3.2.4 Maintainability

The ECHS maintainability objectives are stated herein. No component tests or demonstrations specifically designed for maintainability measurement are specified for this system development. The following items are applicable to all maintainability parameters.

- (a) All preventative and corrective maintenance tasks must be capable of being performed by Army personnel with a skill level equivalent to that of any Army maintenance school graduate with six months on the job experience.
- (b) Crash/battle damage and damage due to operations outside the prescribed limits are excluded from stated maintainability requirements.
- (c) The design shall permit an operating time of 300 flight hours between periodic inspections (in accordance with the latest Aeronautical design standards).
- (d) Environmental conditions shall be as defined in 3.2.5.
- (e) Aviation Unit Maintenance (AVUM) level tasks shall not require more than two men. The majority of AVUM tasks shall require only one man.
- (f) Aviation Intermediate Maintenance (AVIM) support on the external cargo system shall not require more than two men.

3.2.4.1 Corrective Maintenance Manhour to Flight Hour Rates (MMHFH)

The MMHFH for AVUM level of maintenance shall be .0088 MMH/FH for the ECHS. The maintenance requirements stated above are direct productive maintenance times as defined in TM38-750-1.

<u>Maintenance Level</u>	<u>MMHFH</u>
a. Aviation Unit Maintenance	.0008
b. Aviation Intermediate Maintenance	.008

3.2.4.2 Preventive Maintenance Manhour to Flight Hour Rates (MMH/FH)

The ECHS shall have as a maximum the preventive maintenance manhour per flight hour rates as shown below:

<u>Preventive Maintenance</u>	<u>MMHFH</u>
a. Preflight Instl Function Check	.0025
b. Periodic Inspection (300 Flt Hrs)	.0007

Assumes that Preflight Installation Function Check would be performed after each ECHS attachment to the aircraft, and that there would be 30 such attachments in 1000 flight hours.

3.2.4.3 Turnaround Time

Turnaround time is defined as the elapsed time to replenish expendable materials, excluding ammunition, and to perform necessary operational checks in preparing the aircraft for recommitment. This time will not exceed 0.25 hours attributable to the external cargo system using no more than one maintenance person. The aircraft is assumed to be operational mission capable at shutdown.

3.2.5 Environmental Conditions

The ECHS shall not suffer any detrimental effects when exposed to or operated within a temperature range of -65°F to +160°F. Consideration shall be given in the design of the ECHS for the satisfactory operation during the after exposure to any combination of the following conditions in worldwide operations: humidity, fungus, sunshine, rain, snow, sleet, hail, ice-fog, fog, mildew, salt-spray, ice, ozone, smoke, wind, sand and dust.

3.3 Design and Construction**3.3.1 Materials, Processes and Parts**

All materials, processes, and parts shall be selected in accordance with MIL-STD-143 and ANA Bulletin No. 147, and/or Boeing Vertol Company/U.S. Army approved specifications. Every effort will be made to utilize Military Standards (AN, MS, NAS, etc.) where possible.

3.3.1.1 Materials

Materials used in the manufacture of components shall be of high quality, suitable for the purpose and shall conform to applicable Government specification. Materials conforming to contractor's specifications may be used, provided it can be clearly demonstrated that they are at least equivalent to Government specifications with respect to the design and performance requirements specified herein. Contractor's specifications must be satisfactory to the Government and contain provisions for adequate tests. The use of contractor's specifications will not constitute waiver of Government inspection. Design allowables shall be as presented in MIL-HDBK-5C.

3.3.1.1.1 Metals

Metals shall be of the corrosion resistant type or suitably treated to resist corrosion likely to be encountered during storage or service use.

3.3.1.1.2 Dissimilar Metals

Unless suitably protected against electrolytic corrosion, dissimilar metals shall not be used in intimate contact with each other. Dissimilar metals are defined in MIL-STD-889.

3.3.1.1.3 Castings

Castings shall be clean, sound, and free from blow holes, porosity, cracks, and other defects that might reduce their physical properties below specification requirements.

3.3.1.1.4 Forgings

All steel forgings shall be fabricated per MIL-F-7190, Grade A, except tensile test not required. All aluminum forgings shall be fabricated per BMS 7-186 or to the appropriate AMS specification for hand forgings.

3.3.1.2 Standard Parts

AN or MS standard parts shall be used and identified by their standard part numbers, unless they are determined by the manufacturer to be unsuitable for the purpose. Where general purpose standards, as defined by envelope dimensions or Qualified Products Lists (QPLs) are used in critical or high strength applications, parts shall be identified by the vendor's or manufacturer's part number. Parts derived from general purpose standard solely on an inspection selection basis shall be identified by contractor part numbers and all previous identification marks shall be removed.

3.3.1.3 Straight Screw Threads

Straight screw threads shall conform to MIL-S-8879 or MIL-S-7742 as applicable.

3.3.1.4 Safetying

All threaded parts shall be securely locked or safetyed by safety wiring, self-locking nuts or other approved methods. Safety wire shall be applied in accordance with MS33540 and shall conform to MS20995. Star washers and jam nuts shall not be used as locking devices. Use of lock washers shall be governed by limitations set forth in AND10476.

3.3.2 Electrically Operated Components

3.3.2.1 Voltage Range

Electrically operated components shall be designed to operate on 28 volts (V) direct current (dc) or 115V, single phase of 200V, 3 phase, 400 cycles per second (cps) alternating current (ac) in aircraft electrical systems having characteristics as specified in MIL-STD-704

3.3.2.2 Dielectric Strength

All solenoids shall be capable of withstanding a test voltage of not less than, 1500V root mean square (rms), at commercial frequency 60 cycles per second (cps) for 1 minute between terminals and case at maximum operating temperature of the solenoid.

3.3.2.3 Electric Motors

All motors shall be designed to meet the requirements of MIL-M-7969.

3.3.3 Nameplates and Product Marking

3.3.3.1 Marking

All markings shall be insensitive to MIL-L-7808 lubricating oil, MIL-L-23699 lubricating oil, MIL-H-83282 hydraulic fluid and MIL-T-5624 (Grades JP-4 and JP-5) fuels and shall be durable enough to prevent effacing or obliteration due to service usage.

3.3.3.2 Identification

Equipment, assemblies and parts shall be marked for identification in accordance with the requirements of MIL-STD-130.

3.3.4 Workmanship

Workmanship shall be in accordance with high grade aircraft practice and quality to insure safety, proper operation and service life. Workmanship shall be subject to the inspection and approval of the cognizant inspection activity.

3.3.5 Interchangeability and Replaceability

All parts having the same manufacturer's part number shall be directly and completely interchangeable with each other with respect to installation and performance in accordance with MIL-I-8505. Changes in manufacturer's part numbers shall be governed by the drawing number requirements of MIL-D-1000. Subassemblies composed of selected mating components must be interchangeable as assembled units and shall be so indicated on the manufacturer's drawings. The individual components of such assembled units need not be interchangeable.

3.3.6 Safety

The design of the system components whose functions relate to ground or flight safety shall incorporate features to minimize hazardous failure modes or human errors. A subsystem hazard analysis shall be performed to verify incorporation of these features.

3.3.7 Human Performance/Human factors Engineering

The human factors and performance criteria shall be specified in accordance with MIL-STD-1472.

3.4 Logistics

3.4.1 Maintenance

The operational concept shall be in accordance with the provisions of Army Regulation AR 750-1. This regulation describes the characteristics and mission of each level of maintenance from aviation unit maintenance through depot. This concept returns equipment to an operational status normally through replacement of modules and components such as hook assemblies. Maintenance required in replacing components within the external cargo system shall be no more complex than on the current CH-47C helicopter.

3.5 Precedence

In the event of conflict between documents referenced in paragraph 2 of this specification and detailed requirements set forth in this specification, the contents of this specification shall apply.

4.0 QUALITY ASSURANCE PROVISIONS

4.1 General

Quality Assurance tests shall be designed to insure compliance of the external cargo handling system to the requirements of Section 3 of this specification. The quality assurance tests shall be subdivided into two major groups: 1) component qualification and acceptance tests designed to verify that each component of the system will meet the design, functional and environmental criteria

4.1 General - Continued

established for the component; and 2) system integration tests designed to verify that the assembled system performs its function in the helicopter environment.

4.2 Component Qualification Tests

Tests on the components in the ECHS design shall demonstrate the component suitability for its intended use. Principle components requiring functioning and strength tests are:

Hoist Assembly
Load Isolator
Twistlock Actuator
Hoist Control System

In addition, the ECHS structure shall be structurally tested to limit load and the guide system for impact capability.

4.2.1 Hoist Assembly

The hoist assembly, including the cables, shall require strength tests to demonstrate its static and ultimate strengths. Hoist components such as the drive motor may be qualified by similarity if they are identical to existing qualified designs, or limited testing where the design has minor changes from an existing qualified design.

The hoist shall demonstrate its function at design load and speed, maximum operating load, and low loads.

The hoist shall be subjected to environmental tests per MIL-STD-810C.

An endurance test, representative of 3000 cycles shall be conducted. The cycle testing shall consist of 60% at design load (16,250 lb) 20% at 50% of design load (8,125 lb) and 20% at 2,500 lbs. The endurance testing shall be conducted with appropriate rest periods equivalent to the duty cycle defined in paragraph 3.2.1.3.

4.2.2 Load Isolator

The load isolator shall demonstrate the load/deflection and load/spring rate characteristics as defined in paragraph 3.2.1.3.

Endurance testing shall be conducted in conjunction with the hoist testing, paragraph 4.2.1.

4.2.3 Twistlock Actuator

The twistlock actuator, Plessy M422M12 or suitable equivalent, shall demonstrate the strength and speed characteristics defined in Paragraph 3.2.1.4. Environmental qualifications shall be based on similarity to the existing Plessy family or rotary actuators.

4.2.4 Hoist Control System

The hoist control unit shall demonstrate the characteristics defined in Paragraph 3.2.1.5. Environmental testing shall be conducted per MIL-STD-810C.

4.2.5 Structural Tests

4.2.5.1 Limit Load

Structural tests of the ECHS shall be conducted, including the following:

- (a) Limit load test using a MILVAN ballasted as required. The ECHS and its load shall be supported by the two hoist cables.
- (b) Limit load tests using the four corner lift fittings.
- (c) 80% of limit load test using the center attachment and the aft cable. The MILVAN shall be ballasted to represent the 10% CG case.

The limit load tests (a) and (c) above shall be conducted with the snubbing structure preloaded to between 1000 and 1500 pounds at each wheel position.

Limit load tests (a) and (b) shall be conducted with CG in most forward and most aft locations.

4.2.5.2 Ultimate Load Test

Ultimate load test shall be conducted with the ECHS and its load supported by two cables at the hoist locations and the most forward CG location.

4.2.5.3 Guide Impact Test

An impact test shall be conducted to check the strength of the guide system. The unloaded ECHS shall be suspended and impacted against a solid surface at 4 foot/second. Impact shall be in a lateral, longitudinal and vertical direction on a selected guide.

4.3 System Integration Tests

System integration tests shall include: Twistlock system operation, and hoist system operation.

4.3 System Integration Tests (continued)

In addition, the aircraft landing gear will require a vibration test while preloaded to determine the effect on oleo seal life.

4.3.1 Twistlock System

The complete ECHS shall be located over a MILVAN or Standard 8 X 8 X 20 container and the twistlocks actuated using the portable control panel. The interlock function shall be checked at this time. Times to lock and unlock shall be checked. Manual force required to change the twistlock position shall be checked.

4.3.2 Hoist System

A support rig simulating the CH-47D hook and landing gear locations shall be constructed. The rig shall be rigged at an attitude simulating the CH-47D aircraft in hover, and with sufficient clearance to allow the ECHS complete with 8 X 8 X 20 container to be hoisted 10 feet to the snubbed position.

Testing will include all functions of the ECHS using the portable control panel and hoist speed control unit.

4.3.3 Landing Gear Oleo

A landing gear oleo strut complete with wheel and tire shall be positioned in a fixture such that with a preload of 1250 lb. the unit may be subjected to a vibration spectrum to simulate the ECHS/tire interface. Testing shall be concluded for 1500 hours and seal wear monitored.

4.4 Flight Test

Subsequent to the rig testing, the ECHS will require flight testing to: (a) establish the system dynamic stability during acquisition, hoisting, transporting and deposit, (b) determine effects on aircraft control and pilot environment, (c) establish performance limitations, and (d) field testing to determine operating techniques and procedures.

APPENDIX B

SNUB LOAD WIND TUNNEL TEST DATA REPORT

REV LTR

BOEING VERTOL COMPANY

A DIVISION OF THE BOEING COMPANY

P.O. BOX 16858
PHILADELPHIA, PENNSYLVANIA 19142

CODE IDENT. NO. 77272

NUMBER 8-7891-1-445

TITLE UMWT 839: A LOW SPEED WIND TUNNEL TEST
OF CH-47 WITH SNUBLOAD ADAPTER

ORIGINAL RELEASE DATE _____ . FOR THE RELEASE DATE OF
SUBSEQUENT REVISIONS, SEE THE REVISION SHEET. FOR LIMITATIONS
IMPOSED ON THE DISTRIBUTION AND USE OF INFORMATION CONTAINED
IN THIS DOCUMENT, SEE THE LIMITATIONS SHEET.

MODEL VR143 CONTRACT _____

ISSUE NO. _____ ISSUED TO: _____

PREPARED BY

David Hodder

D. J. Hodder

DATE 4-13-79

APPROVED BY

D.G. Ekquist

D.G. Ekquist

DATE 4-19-79

APPROVED BY _____

DATE _____

APPROVED BY _____

DATE _____

LIST OF ILLUSTRATIONS

<u>Figure</u>		<u>Page</u>
1	Reynolds Number Effect	6
2	Data Hysteresis ~ Yaw Run	7
3	Configuration Comparison ~ Drag	8
4	Configuration Stability Comparison	9
5	Flow On Ramp ~ Run 6	12
6	Flow On Ramp ~ Run 7	13
7	Flow On MILVAN ~ Run 6	14
8	Flow On MILVAN ~ Run 7	15
9	Run 14 with Basic Adapter A ₁	16
10	Run 64 Adapter A _{4.1.2}	17
11	CH-47 Base Configuration K ₁	21
12	Location of Tufted Area for Bumstead Run	22
13	Adapter A ~ Basic Dimensions	24
14	Adapter A ₁	25
15	Adapter A _{1.1}	27
16	Adapter A _{2.1}	32
17	Adapter A _{3.1}	34
18	Adapter A _{3.2}	36
19	Adapter A _{3.1}	37
20	Adapter A _{4.0}	40
21	Adapter A _{4.1}	42
22	Gondola G1; Gondola G2	44
23	MILVAN M1 On Struts	46
24	MILVAN M1 On Fuselage Underside	47

LIST OF ILLUSTRATIONS (Continued)

<u>Figure</u>		<u>Page</u>
25	Struts S_1^{15}	49
26	Struts S_2	51
27	Transition Strips TS1	53
28	Roof Static Pressure Signature $\alpha = -10^\circ$	55
29	Pressure Ports Location	56
30	Moment Transfer	59
31	Roof Static Pressure Signature $\alpha = -10^\circ$	60
32	Roof Static Pressure Signature $\alpha = -10^\circ$	61
33	Roof Static Pressure Signature $\alpha = -10^\circ$, $\psi = -15$	62
34	Roof Static Pressure Signature $\alpha = -10^\circ$, $\psi = -30^\circ$	63
35	Wake Sizes	70
36	Wake Sizes	71

UMWT 839 REPORT CONTENTS

Section	Title	Page
1.	SUMMARY	
1.1	Test Date and Location	2
1.2	Test Authorizations	2
1.3	Model Description	2
1.4	Test Request (WTTR 220)	2
1.5	Test Details	3
1.6	Data Acquired	4
2.	DATA SUMMARY	5
3.	MODEL DESCRIPTION	
3.1	Basic CH-47 Model	18
3.2	Adapter	21
3.3	Gondola	23
3.4	Milvan	43
3.5	Struts	45
3.6	Transition Strips	48
4.	INSTRUMENTATION	53
5.	DATA REDUCTION	54
5.1	Moment Transfer	58
5.2	Blockage Corrections	59
5.3	Final Data Format	64
6.	RUN LOG	69
7.	PHOTOGRAPH LOG	72
8.	TEST DATA	80
		81

WIND TUNNEL TEST UMWT 8391. SUMMARY1.1 Test Date and Location

The subject test was performed at the University of Maryland Low Speed Wind Tunnel from February 12 to February 16, 1979.

1.2 Test Authorizations

WTTR 220
WPD 7000-50079-61142-000000
WPD 7000-52340-71531-000000

1.3 Model Description

The VR-143 Model used for this test was the 0.125 scale CH-47 drag model, which was installed in the working section, inverted, on the short support strut. The inverted position was chosen as being the most convenient for mounting of the Adapter and loads on the fuselage underside. A short support strut, which located the model pivot some 10.3 in. below the external balance virtual center, was used in order to place the Milvan load as far as possible from the tunnel roof.

The short strut incorporated a yawing drive system which rotated the strut and model without moving the turntable or strut windshield. Since only incremental data were required, no attempt was made to determine tare and interference effects of the support system.

The Adapter, Milvan and Gondola with FARRP Load were scaled as to present design configuration and attachment points. In order to simulate sling loading, heavily knurled struts were used to support the Milvan at various distances from the model fuselage underside. It was found necessary when testing to provide additional support to the four box corners by bracing with 0.020 in. dia. music wire.

1.4 Test Request

(WTTR 220 enclosed, following)

WIND TUNNEL TEST REQUEST

ACCOUNTING CHARGE NUMBER						FOR WIND TUNNEL USE ONLY			
1. WIP	2. CTL. CODE	3. PROJECT NO.	4. SUB NO.	5. SERIAL NO.	6. LABOR CODE	TEST REQUEST NO.			PAGE
	7000	52340	71531	000000		220			1 OF 4
DATA COLLECTION NO.						DIVISION	PROGRAM	MODEL NO.	TYPE TEST
REQUESTED BY: T. Garnett						ISSUED		REVISED	REV. NO.
PREPARED BY: D. J. Hodder 2/13/79						APPROVED BY			
						WIND TUNNEL PROJECT ENGINEER			

TITLE:

CH-47 EXTERNAL CARGO HANDLING SYSTEMS
(SNUBBED LOAD) -- WIND TUNNEL TEST

DESCRIPTION OF TEST

1. BACKGROUND & OBJECTIVES

The principal objective of this program is to conduct a best-effort preliminary wind tunnel evaluation of the CH-47 helicopter load snubbing concept.

Potential aerodynamic problems arising from "snubbing" large external payloads (such as MILVAN cargo containers, etc.) to the CH-47 airframe, need to be identified at an early stage in design development of a load snubbing system for the helicopter. Because of complex flow interference existing between the fuselage and load, the task of evaluating combined load/fuselage aerodynamics is not readily amenable to conventional theoretical analysis. Using the wind tunnel approach as a design tool, on the other hand, will provide the required aerodynamic stability and performance information for snubbed loads.

Initial testing will include a generalized look at load snubbing aerodynamics for a simple MILVAN payload, followed by assessment for force and moment characteristics with a MILVAN mounted on a snubbing adapter device which is attached to the aircraft. GONDOLA aerodynamic characteristics will also be measured; first with the load installed on the snubbing device, and then on simulated sling suspensions beneath the aircraft.

The planned program considers a 5 day, 8 to 10 hour shift (or equivalent) tunnel occupancy (44 hrs.) in the University of Maryland Wind Tunnel. Anticipated test dates are from Monday, February 12, through Friday, February 16, 1979.

2. SUMMARY WORK STATEMENT

Testing will be conducted in three phases as follows:

Phase 1. Generalized Evaluation of Load Snubbing Aerodynamics

- o Perform an aerodynamic evaluation of MILVAN load snubbing, by executing a series of pitch and yaw runs, with the load

DISTRIBUTION	D. Ekquist	P38-07
W. Lapinski	P38-07	D. Hodder
H. Parkinson	P38-01	P38-07

WIND TUNNEL TEST REQUEST NO. 220 (Continued)

2. SUMMARY WORK STATEMENT (Cont'd)

Phase 1. Generalized Evaluation of Load Snubbing Aerodynamics
(Cont'd)

mounted on struts at several different heights
(probably three) beneath the fuselage.

- o If practical, determine the minimum distance between the load and airframe, beneath which load/airframe interference effects become sufficiently large that they would adversely influence aircraft stability and/or performance for terrain and IMC flight operations.

Phase 2. Snubbing Device/MILVAN Payload Evaluation

Perform a combined MILVAN/snubbing device aerodynamic evaluation by executing pitch and yaw runs, following the data acquisition priorities listed below:

- o BASIC AIRCRAFT - To acquire "baseline" force and moment data, with snubbing device and load removed. (NOTE: These runs will probably be made during Phase 1 generalized snubbing testing.)
- o BASIC A/C + SNUBBING DEVICE + MILVAN--Force and moment pitch and yaw runs.
- o BASIC A/C + SNUBBING DEVICE + MILVAN--Flow visualization runs to identify areas of disturbed flow.
- o BASIC A/C + SNUBBING DEVICE + MILVAN + FLOW DIRECTOR VANES--Attempt to reduce areas of turbulent or separated flow--flow viz/force and moment data.
- o BASIC A/C + SNUBBING DEVICE ONLY--Force and moment data if test time permits.

All force and moment test results will be reduced to a tabular format for inclusion in the data report.

Phase 3. GONDOLA Evaluation

Evaluate GONDOLA force and moment aerodynamic characteristics, with the GONDOLA mounted on the Snubbing Device attached to the aircraft.

- o Empty configuration
- o Partially loaded configuration

WIND TUNNEL TEST REQUEST NO. 220 (Continued)

2. SUMMARY WORK STATEMENT (Cont'd)

Phase 3. GONDOLA Evaluation (Cont'd)

Evaluate GONDOLA ero characteristics with the GONDOLA mounted on "sling"/strut attachments.

- o Struts only--baseline
- o Struts + GONDOLA
- o Struts + GONDOLA + Partial Load

3. MODEL COMPONENT DESIGN

3.1 For MILVAN Payload/Snubbing Device Evaluation

Design 1/8 scale model components for the "generalized load snubbing," and "snubbing device/MILVAN payload" evaluation test phases, including:

- o 3 Cargo hooks and simulated cable
- o 1 Snubbing device framework
- o 1 8x8x20 MILVAN container
- o 1 Set--flow director/turning vanes
- o 3 Sets--Mounting struts for "MILVAN only" generalized evaluation of load snubbing aerodynamics
- o Miscellaneous attachment hardware

3.2 For GONDOLA Evaluation

- o Using drawings supplied by ATL/AVRADCOM, design 1/8 scale model GONDOLA configuration; with suitable attachment hardware to mount the device either on the snubbing adapter, or on inverted "V" struts which simulate sling suspension of the load.
- o Design "V" strut "sling" mounts and fuselage attachments for the forward and aft suspensions.
- o Design a typical GONDOLA payload (to be defined by ATL), such as equipment required for resupply of the FARRP (forward area rearm and refuel point).

WIND TUNNEL TEST REQUEST NO. 220 (Continued)

4. MODEL COMPONENT FABRICATION

4.1 For MILVAN Payload/Snubbing Device Evaluation

Fabricate all model components designed under 3.1. Assemble, pack/unpack. Supervise fabrication, assembly, packing, and unpacking, and perform required liaison.

4.2 For GONDOLA Evaluation

Fabricate items listed under 3.1 including the GONDOLA, "V" strut mounts, and one typical GONDOLA partial payload.

5. MODEL TEST

The Wind Tunnel Test Group will provide support to perform the following functions:

- 5.1 Pre-test coordination with the U. of Md. Wind Tunnel.
- 5.2 Direction during test occupancy, including: pre-installation running required for data correction method, model installation, calibrations and checkout, data runs, etc.
- 5.3 Formulation of special methods for data correction.
- 5.4 Production of a memo report following completion of testing.

1.5 Test Details

All testing was conducted with the model inverted. A row of static pressure orifices was installed stream-wise on the roof centerline to assist in an assessment of the wall corrections. Special treatment was necessary to determine these corrections, in view of the large bluff body wake generated by the Milvan. Initial runs were made as follows:

1. Clean working section sampling of roof static for pressure signature baseline; dynamic pressures of 30, 50, 75, 100 psf.
2. Model installed, transition strips applied, Reynolds No. effect investigation @ $q = 30, 50, 75, 100$.
3. Clean model baseline data @ $q = 75, 50$ psf, pitch and yaw sweeps.
4. Milvan installed on struts, pressure signature data and yaw hysteresis run.

From these investigations, it was established that a dynamic pressure of 50 psf was suitable for running, dropping to 30 psf for yaw angles of 60° and 90° . Also that the UMWT centerline static ports in the working section could probably be used to obtain a blockage corrected velocity measurement, pending further in-depth pressure data evaluation.
(Section 5.2)

Data were obtained for the Milvan on various length struts and then for the Adapter basic configuration plus Milvan. Modifications were made to the Adapter in order to reduce drag, involving the use of fairings, etc. Also investigated were the effects of changing Adapter to fuselage surface gaps and angle.

Drag and lateral stability data for the various configurations are given in the Data Summary, Section 2, following.

1.6 Data Acquired

- From the wind tunnel instrumentation:
 1. Dynamic pressure based on working section entrance statics.
 2. Dynamic pressure based on working section centerline static.
 3. Selected Runs: pressure signature from roof static ports
 4. Model yaw angle.
- From the external balance:
 1. Full scale coefficients (FT^2 and FT^3) of forces and moments, transferred to CG location in wind axes.
 2. Full scale coefficients in body axes. (These corrected for wind off zero and weight tares.)
- From the model:
 1. Model pitch angle.
 2. Pressure data from ramp and Milvan rear.

2. DATA SUMMARY -- UMWT 839

All data from the external virtual center balance were transferred to aircraft full scale CG and printed out in full scale effective units of square feet and cubic feet.

Dynamic pressure corrections were automatically incorporated by using a working section centerline static pressure measurement. Data from this was checked against working section entrance free-stream conditions corrected by established methods for assessing the velocity increment due to the constraint of an axi-symmetric bluff body wake.

Final reduced data showed that Reynolds No. effects were small through the test range. A dynamic pressure of 50 psf was chosen for the test as being the highest velocity attainable without overloading the external balance. At high yaw angles, 60° and 90°, the dynamic pressure was reduced to 30 psf for this reason.
(Run 2, Fig. 1)

A check was made of hysteresis effects on yawing moment (Run 7, Fig. 2), which were found to be negligible.

Drag data are summarized in Fig. 3, showing that the basic adapter drag increment was reduced by about 20 sq. ft. by modification. For this configuration, the adapter increment amounted to 6 sq. ft. Much of the benefit came from a de-cambering effect, moving the minimum drag from +6° incidence for the unmodified adapter and Milvan, to +2° for the modified load.

Stability data (Fig. 4) for the basic aircraft as tested, and with the modified adapter and Milvan are plotted to show that the effect of the load gives an improvement in lateral stability.

Drag increments for comparison are listed in the table following the figures.

This section also includes flow visualization sketches of tuft behavior on the significant configurations. Figs. 5, 6, 7, 8, 9, 10.

UNIT 307

REVISIONS NO. EFFECT

- Rev 2
- CH47 BASE CONFIG + TRANSITION STRIPS
- $\alpha = -10^\circ$ $24 + 30^\circ$

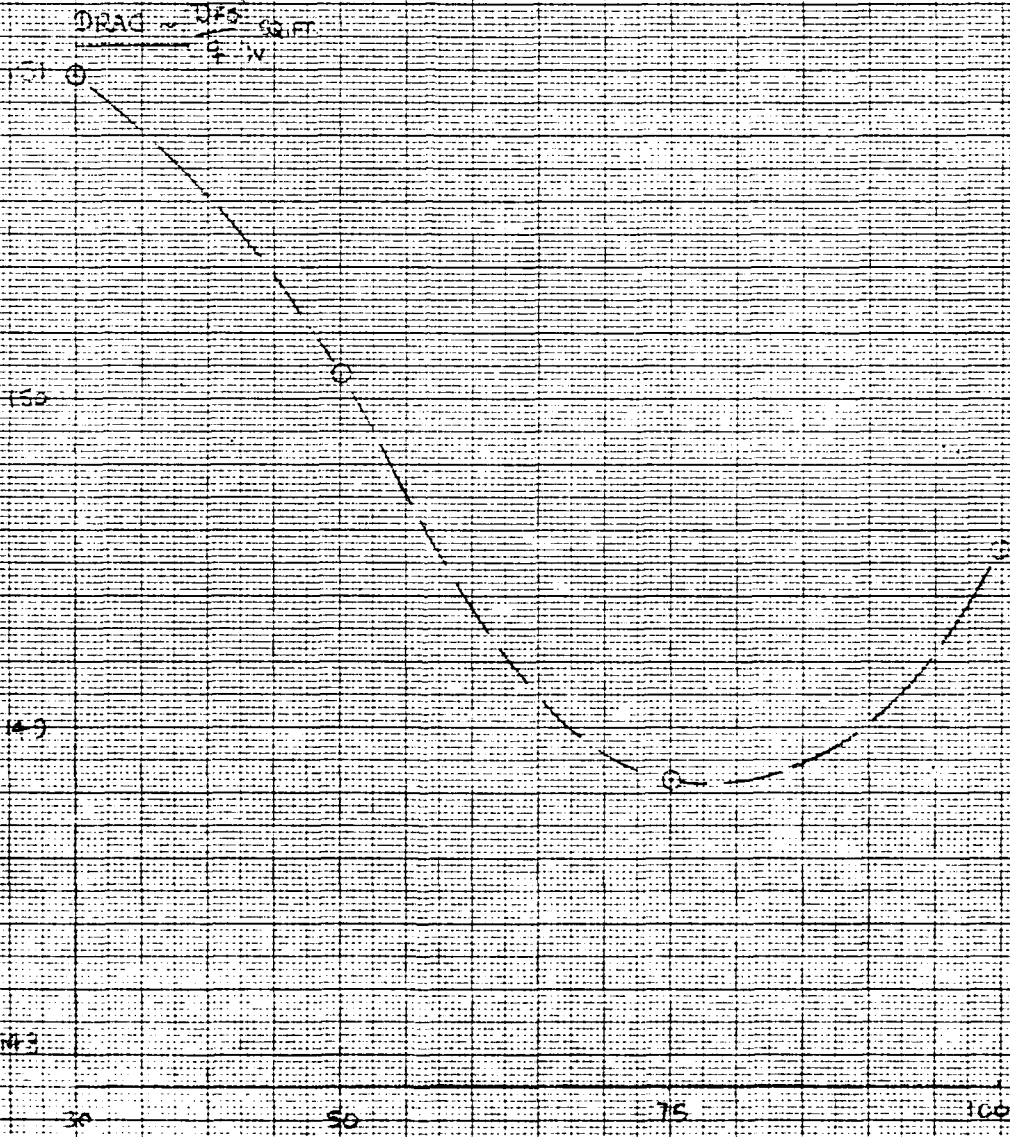

DYNAMIC PRESSURE
* $\frac{\rho V^2}{2}$

FIG. 1

DIETZEN CORPORATION
MADE IN U.S.A.

NO. 300-IMP DIETZEN GRAPH PAPER
MILLIMETER

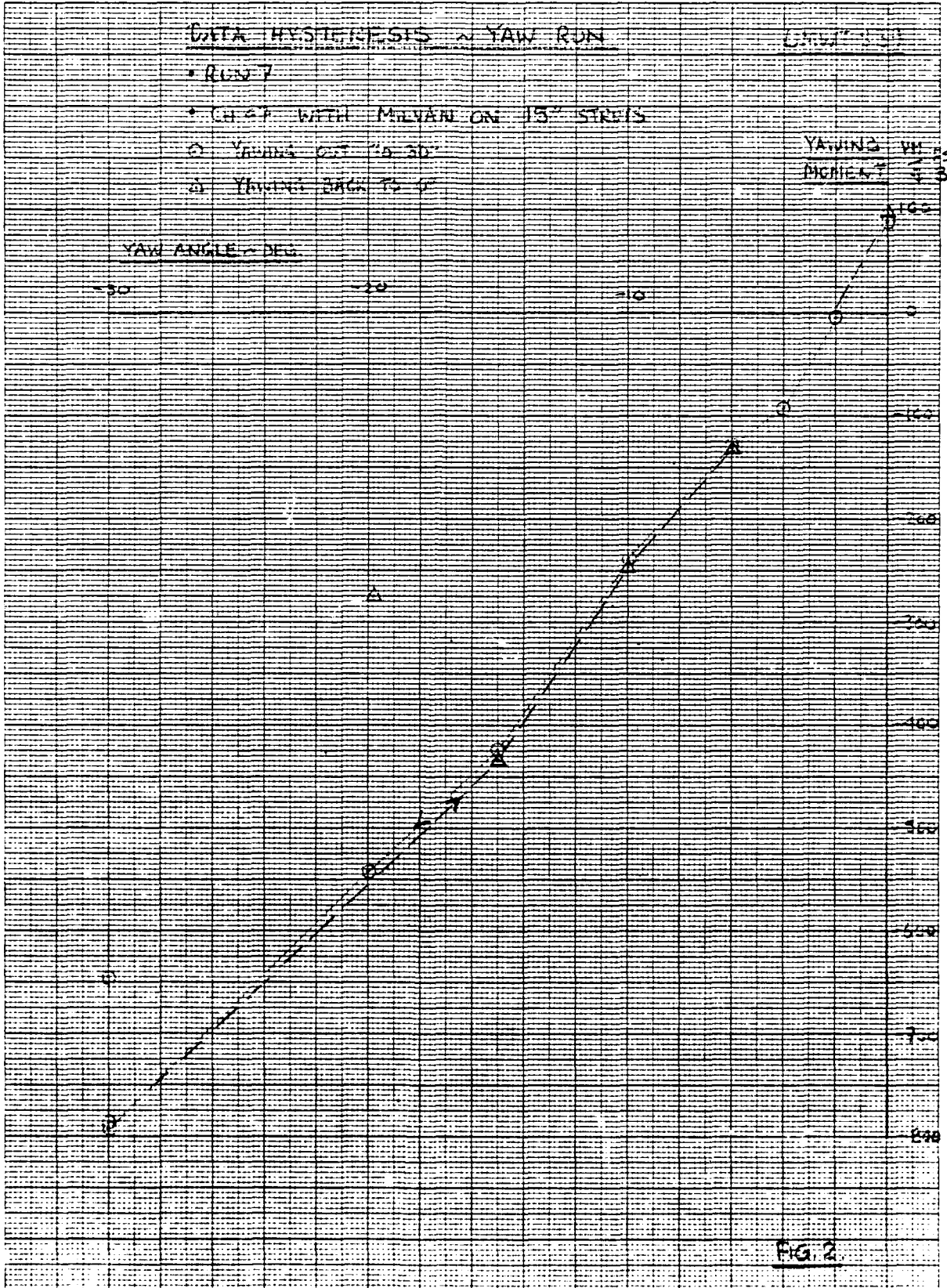

DIETZGEN CORPORATION
MADE IN U.S.A.

NO. 340R-MP DIETZGEN GRAPH PAPER
MILLIMETER

CONFIGURATION	COMPARISONS	DATE	UNIT
○ MILVAN ON BASIC ADAPTER AT		RUN 14	
△ MILVAN ON MODIFIED ADAPTER A4-11		RUN 12	
X GREATEST DRAG REDUCTION A37-5		RUN 12	
● MILVAN 15" FROM FUSELAGE STRUTS		RUN 6	

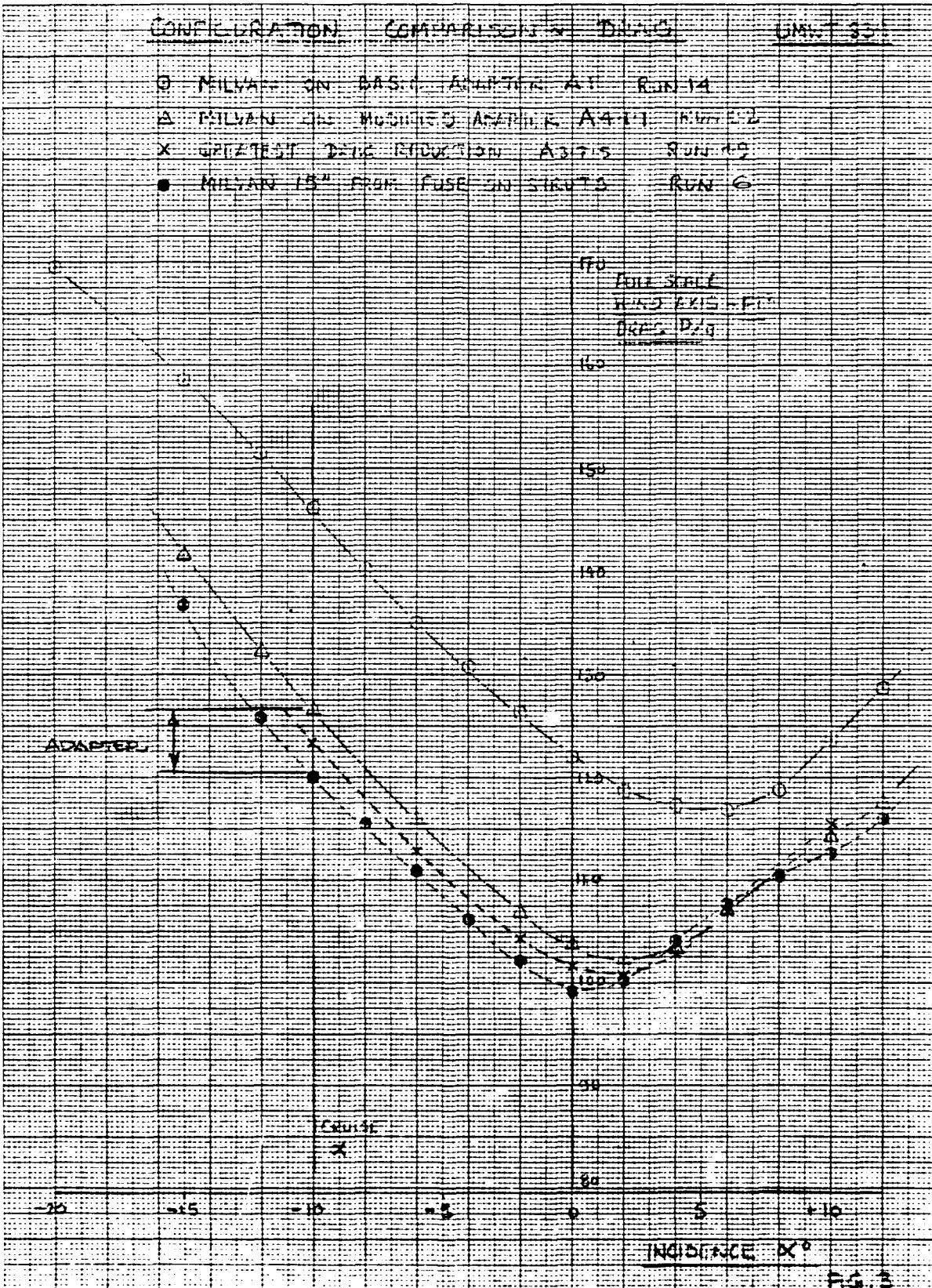

DIETZEN CORPORATION
MADE IN U. S. A.

NO. 340R-MP DIETZEN GRAPH PAPER
MILLIMETER

COMPARISON	ACTIVITY	CLASSIFICATION	DATE
0 - BASIC AIRCRAFT	NO LOAD	RUN 5	
1 - MILITARY AIRCRAFT		RUN 15	

Full Scale YIM
= F12

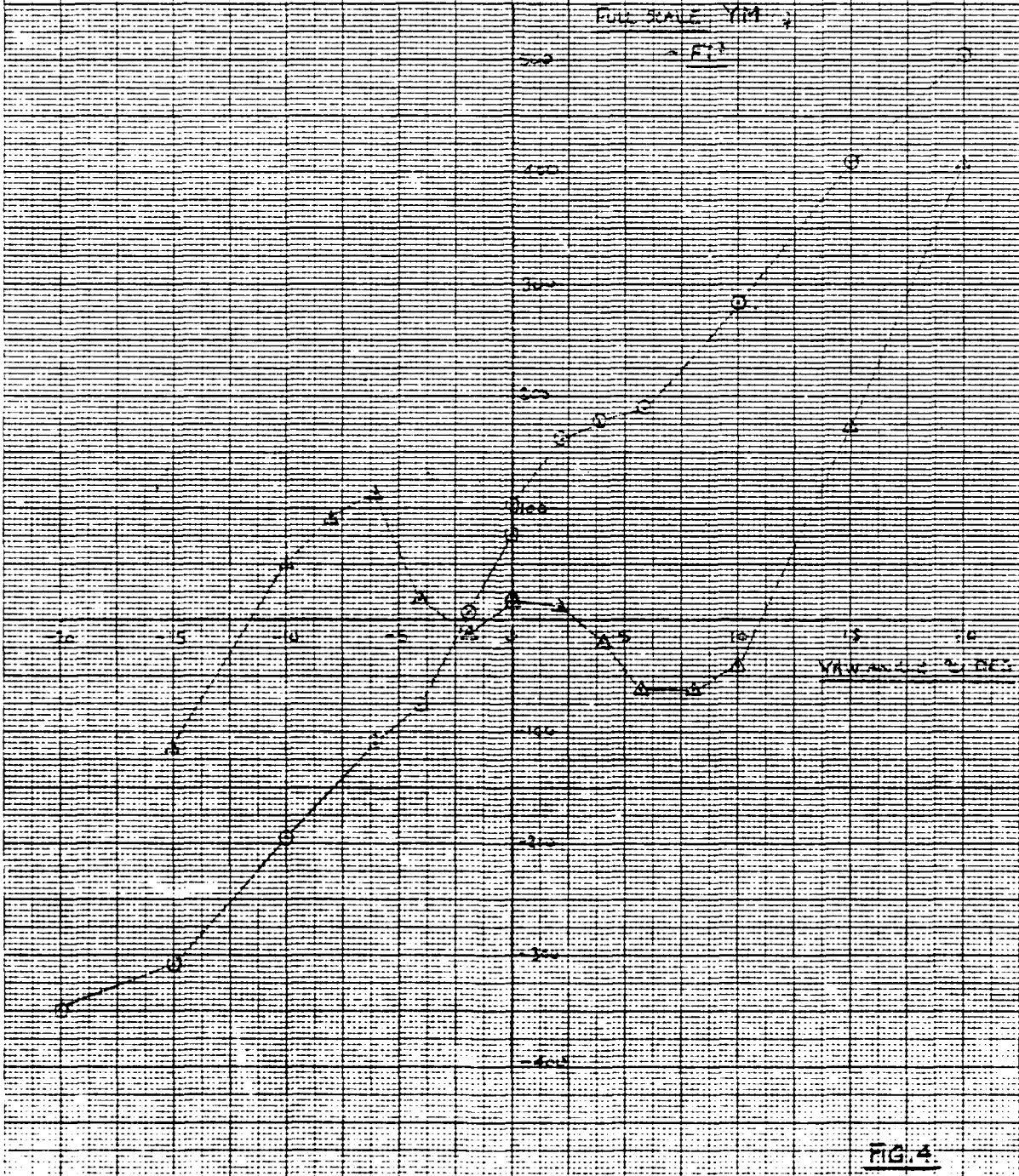

FIG. 4

DIETZEN CORPORATION
MADE IN U.S.A.

NO. 340R-MP DIETZEN GRAPH PAPER
MILLIMETER

COMPONENT DRAG

Wind Axis Drag in FS Sq. Ft. @ $\psi = 0$ $\alpha = -10^\circ$

Configuration	Run(s)	Drag
Basic CH47	3	38.77
Milvan Struts 5"	67-3	2.80Δ
10"	69-3	5.10Δ
15"	65-3	7.27Δ
Milvan on 5" Struts	12-3	74.78Δ
10"	8-3	79.85Δ
15"	6-3	81.81Δ
Milvan Alone (-Struts) 5"		71.98ΔΔ
10"		74.75ΔΔ
15"		74.54ΔΔ
Gondola Struts 10"	57-3	7.05Δ
Full Gondola, Struts	53-3	81.90Δ
Empty Gondola, Struts	55-3	66.89Δ
Gondola Alone (Full)		74.85ΔΔ
Gondola Alone (Empty)		59.84ΔΔ
Milvan (On Fuse)	10-3	69.57Δ
Milvan on Adapter A1	14-3	107.39Δ
A1.1 V1	16-3	108.06Δ
A1.2	18-3	117.95Δ
A1.3	20-3	109.36Δ
A1.4	21-3	107.16Δ
A1.5	22-3	108.14Δ
A2.1	23-3	99.43Δ
A2.2	24-3	97.64Δ
A3.1	26-3	92.72Δ
A3.2	28-3	88.03Δ
A3.3	29-3	88.50Δ
A3.4	30-3	89.63Δ
A3.5	31-3	83.75Δ
A3.6	33-3	85.76Δ
A3.7	36-3	84.93Δ
A3.7.2	46-3	85.27Δ
A3.7.3	47-3	86.40Δ
A3.7.4	48-3	85.44Δ
A3.7.5	49-3	84.79Δ
A3.7.6	50-3	85.21Δ
A3.7.7	51-3	90.20Δ
A4.0	59-3	87.25Δ

Milvan on Adapter A4.1	61-3	87.99Δ
A4.1.1	62-3	87.89Δ
A4.1.2	64-3	89.43Δ
Gondola on Adapter A3.7.1		
Full	42-3	81.61Δ
Empty	44-3	65.10Δ

FLOW ON RAMP

RUN 6

UMWT 939

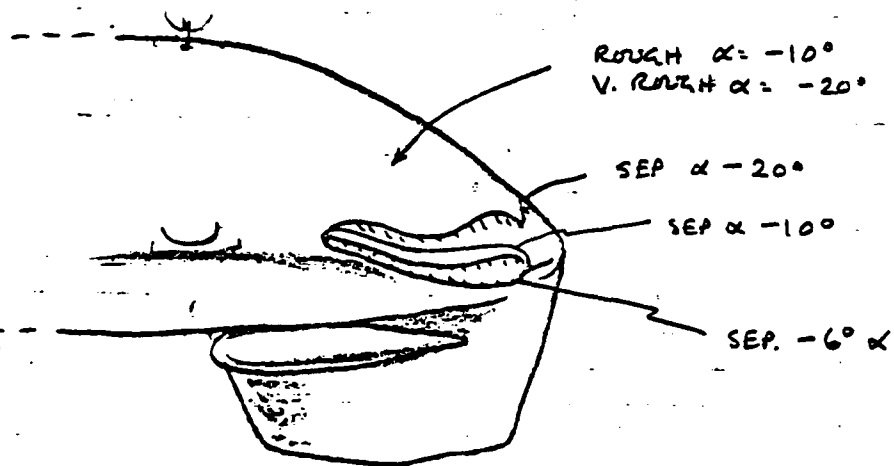
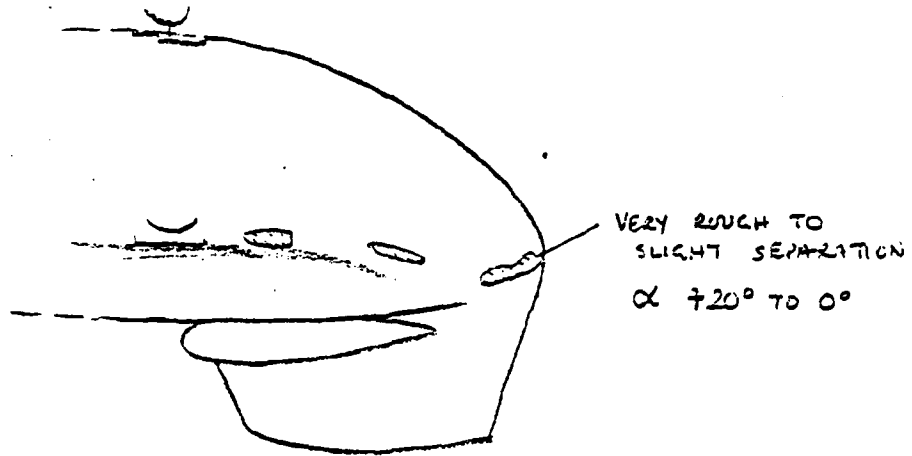
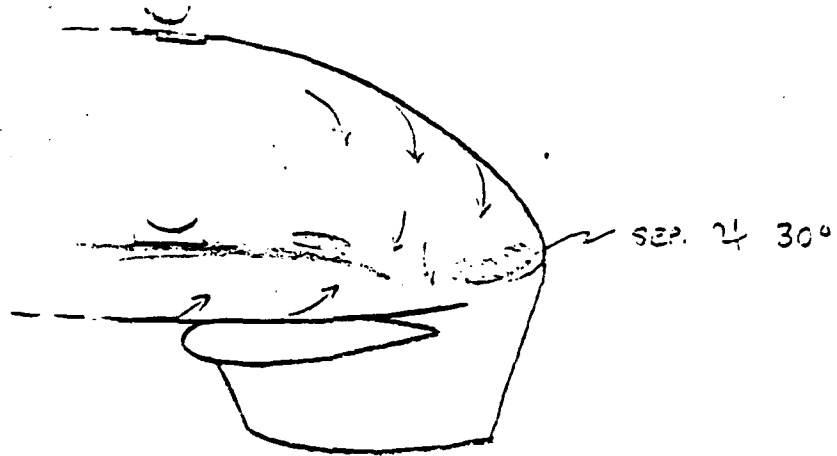

FIG. 5.

FLOW ON RAMP

RUN 7

UMWT 839



SEP. @ 30°

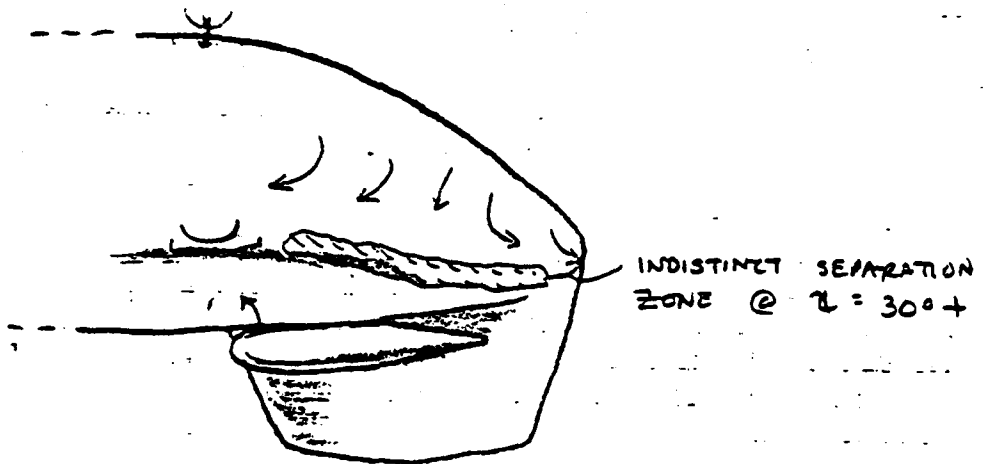

INDISTINCT SEPARATION
ZONE @ $\alpha = 30^\circ +$

FIG. 6.

FLOW ON MILVAN

RUN 6

UMWT 833

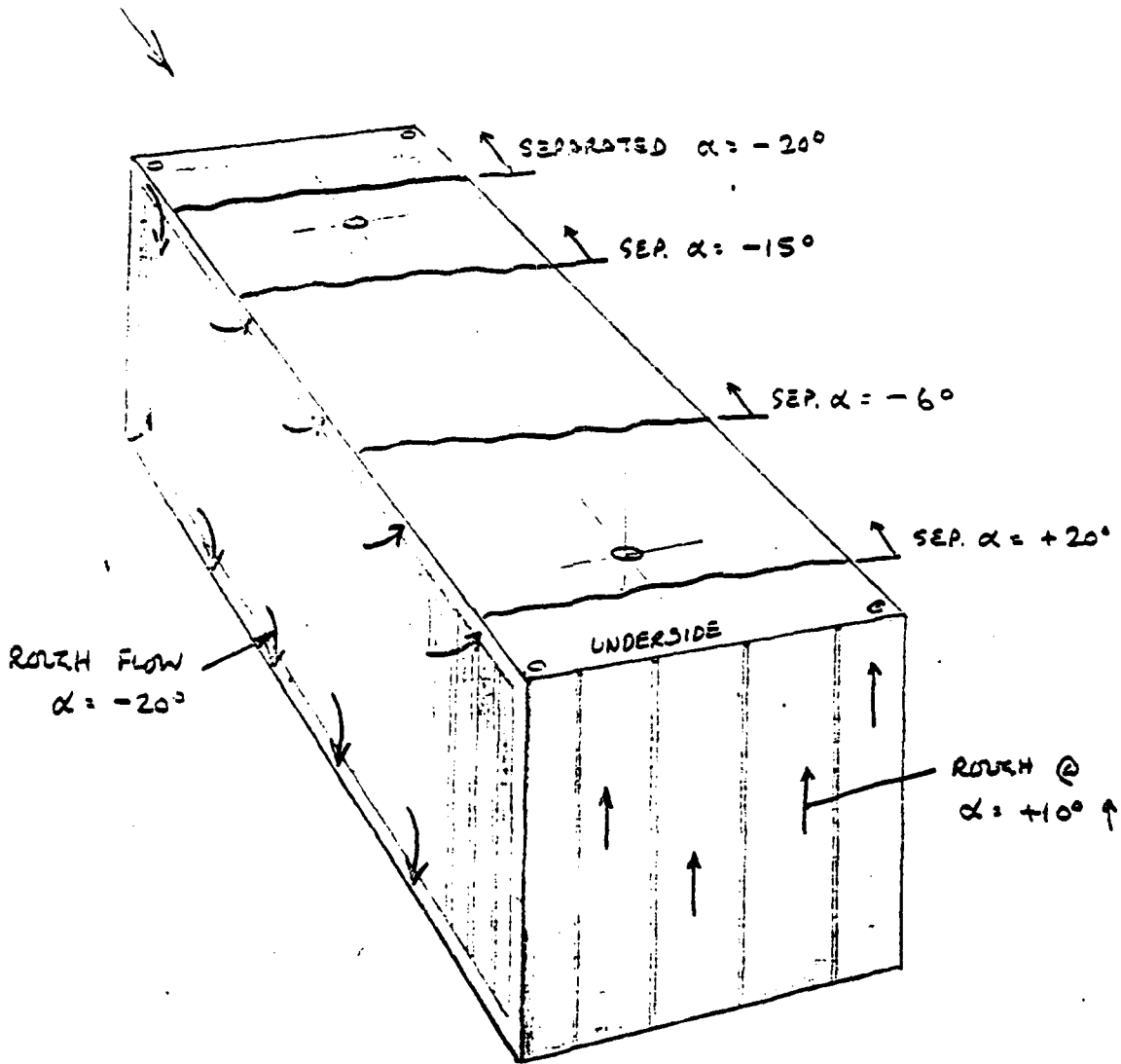

BOX SHOWN INVERTED FROM RUN POSITION

FIG. 7

FLOW ON MILVAN

RUN 7

UMWT 839

($\alpha = -10^\circ$)

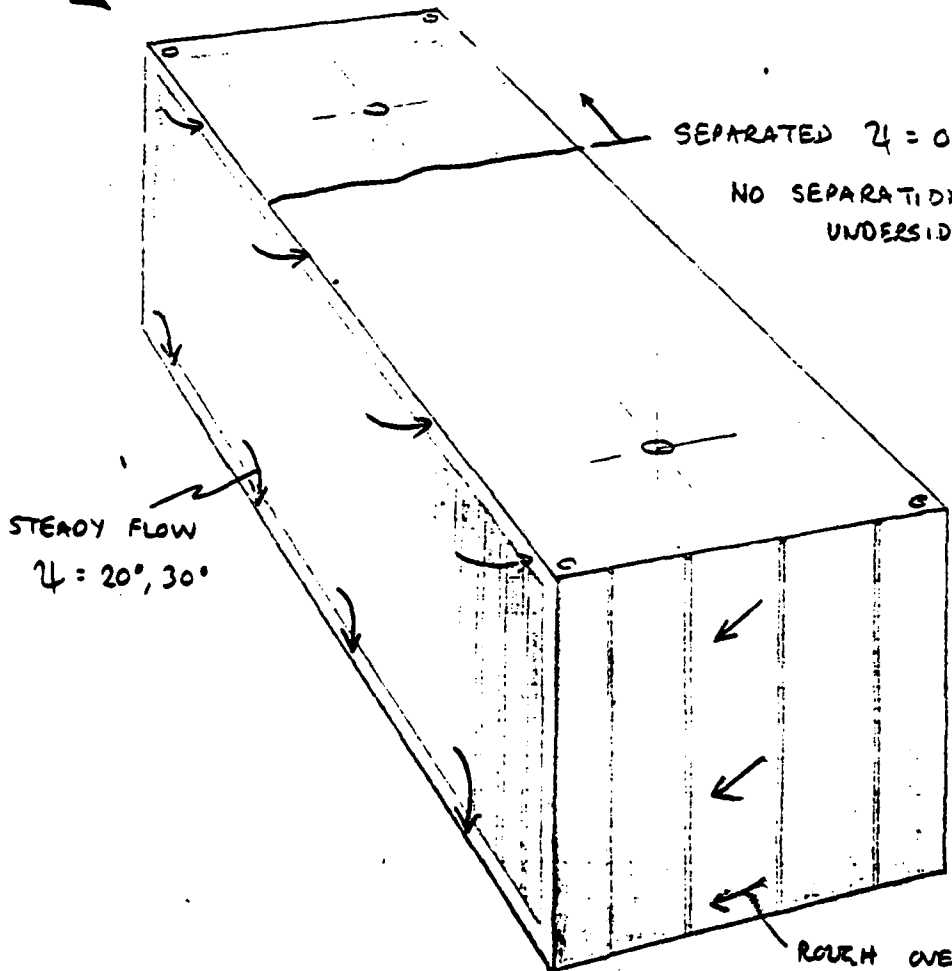

SEPARATED $\gamma = 0, \pm 10^\circ$

NO SEPARATION ON
UNDERSIDE $\gamma = 20^\circ +$

STEADY FLOW
 $\gamma = 20^\circ, 30^\circ$

ROUGH OVER $\gamma 20^\circ$

BOX SHOWN INVERTED FROM RUN POSITION.

FIG 8

ROW 14.
WITH BASIC ADAPTER A1

LMWT 839

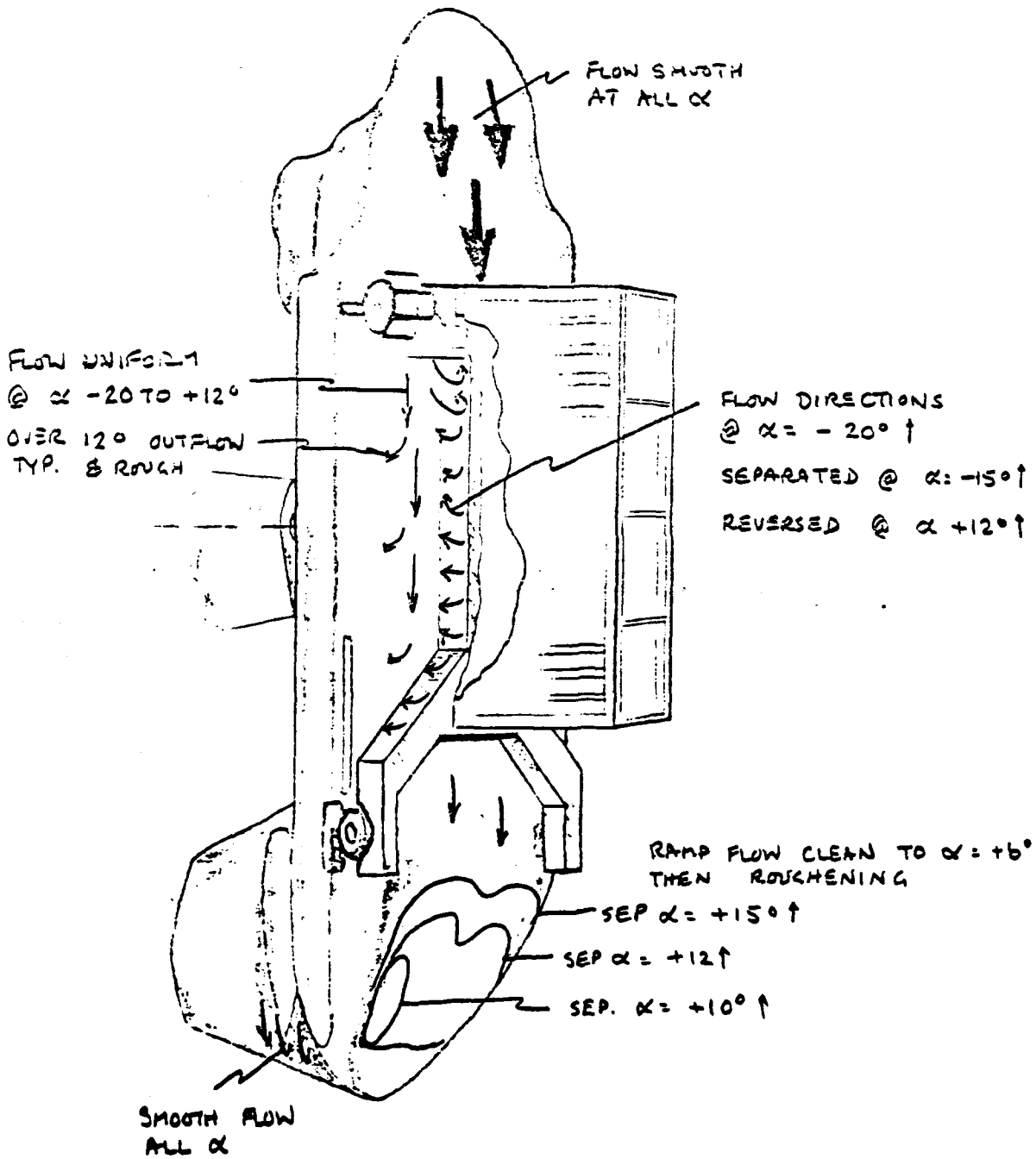

FIG 9

ADAPTER A 4.1.2
RUN 64.

LMWT 839

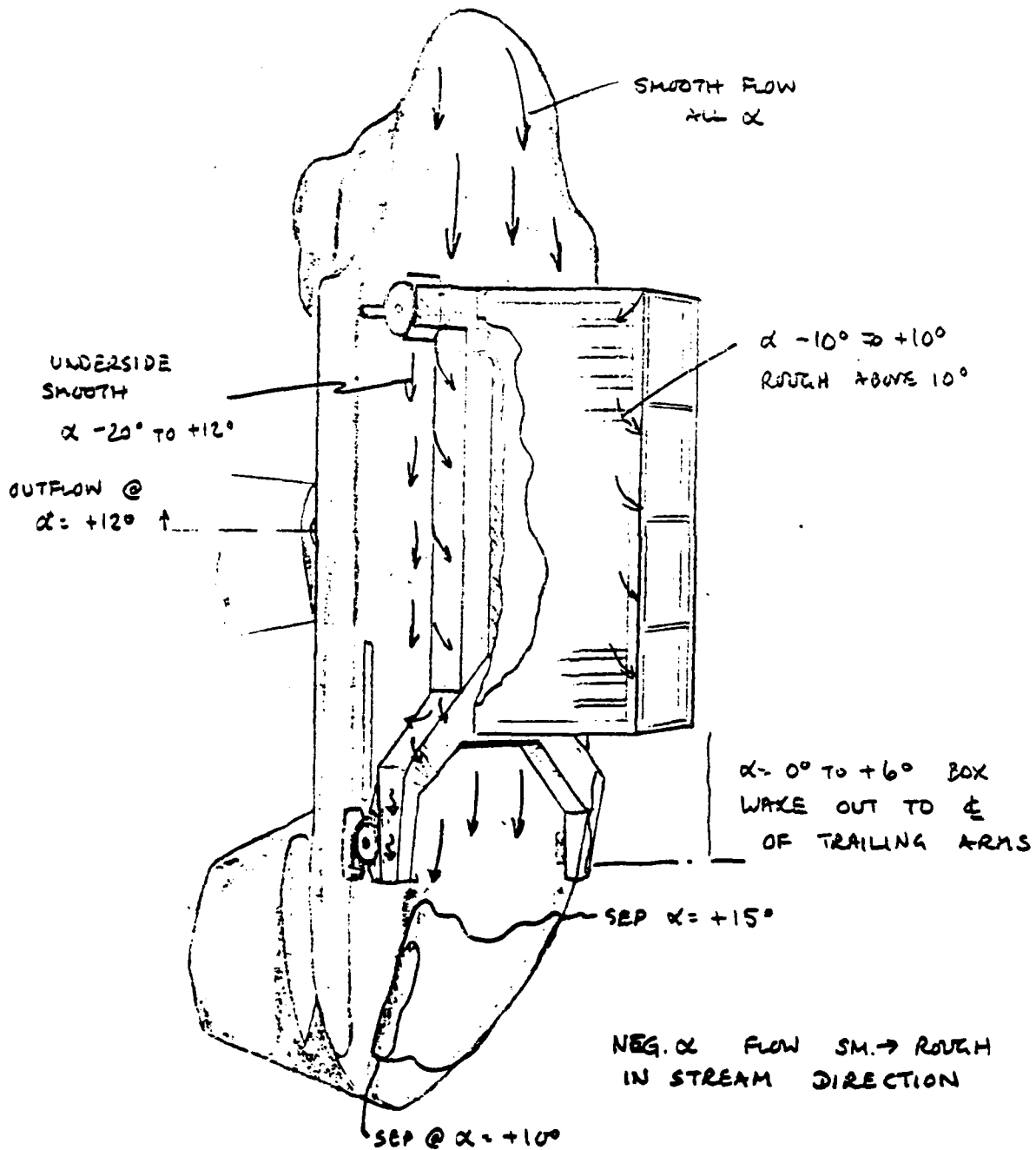

FIG 10

3. MODEL DESCRIPTION

This section contains full descriptions of the model components as tested.

The model used for the test was the VR-143 0.125 Scale CH-47 drag model, constructed of wood on a steel chassis. The chassis provided anchoring points for the various components of the basic rotorcraft, and contained the electric pitch actuator and angle readout.

An inverted model position was chosen as the only way of testing items to be located below the fuselage lower surface. Since some positions of the Milvan (mounted on struts) would bring this load uncomfortably close to the working section roof, the UMWT short mounting strut was used. No image system was used, as only incremental data was of interest.

Components described herein are as follows:

Section	Component	Figure
3.1	CH-47 Basic Model	11
	Tufting for Bumstead Run	12
3.2	Adapter A1	13,14
	A1.1	15
	A1.2	-
	A1.3	-
	A1.4	-
	A1.5	-
	A2.1	16
	A2.2	-
	A3.1	17
	A3.2	18
	A3.3	-
	A3.4	-
	A3.5	-
	A3.6	-
	A3.7	19
	A3.7.1	-
	A3.7.2	-
	A3.7.3	-
	A3.7.4	-
	A3.7.5	-
A3.7.6	-	
A3.7.7	-	
A4.0	20	
A4.1	21	
A4.1.1	-	
A4.1.2	-	

Section	Component	Figure
3.3	Gondola G1	22
	G2	22
3.4	Milvan M1, on struts	23
	Milvan M1, on fuselage	24
	Milvan M1, on Adapter	-
3.5	Struts S1	25
	S2	26
3.6	Transition Strips TS1	27

UMWT 839 COMPONENT DRAWING LIST

<u>Part</u>	<u>Dwg. No.</u>	
MILVAN	VR143P 002	2 shts
GONDOLA	VR143P 003	4 shts
ADAPTER	VR143P 004	1 sht
ACTUATOR ROD	VR143P 005	1 sht
PRESSURE LOCATIONS	VR143P 006	1 sht
FUSELAGE ANCHOR PLATE	VR143P 007	1 sht

3.1 0125 SCALE CH-47

UMWT 339

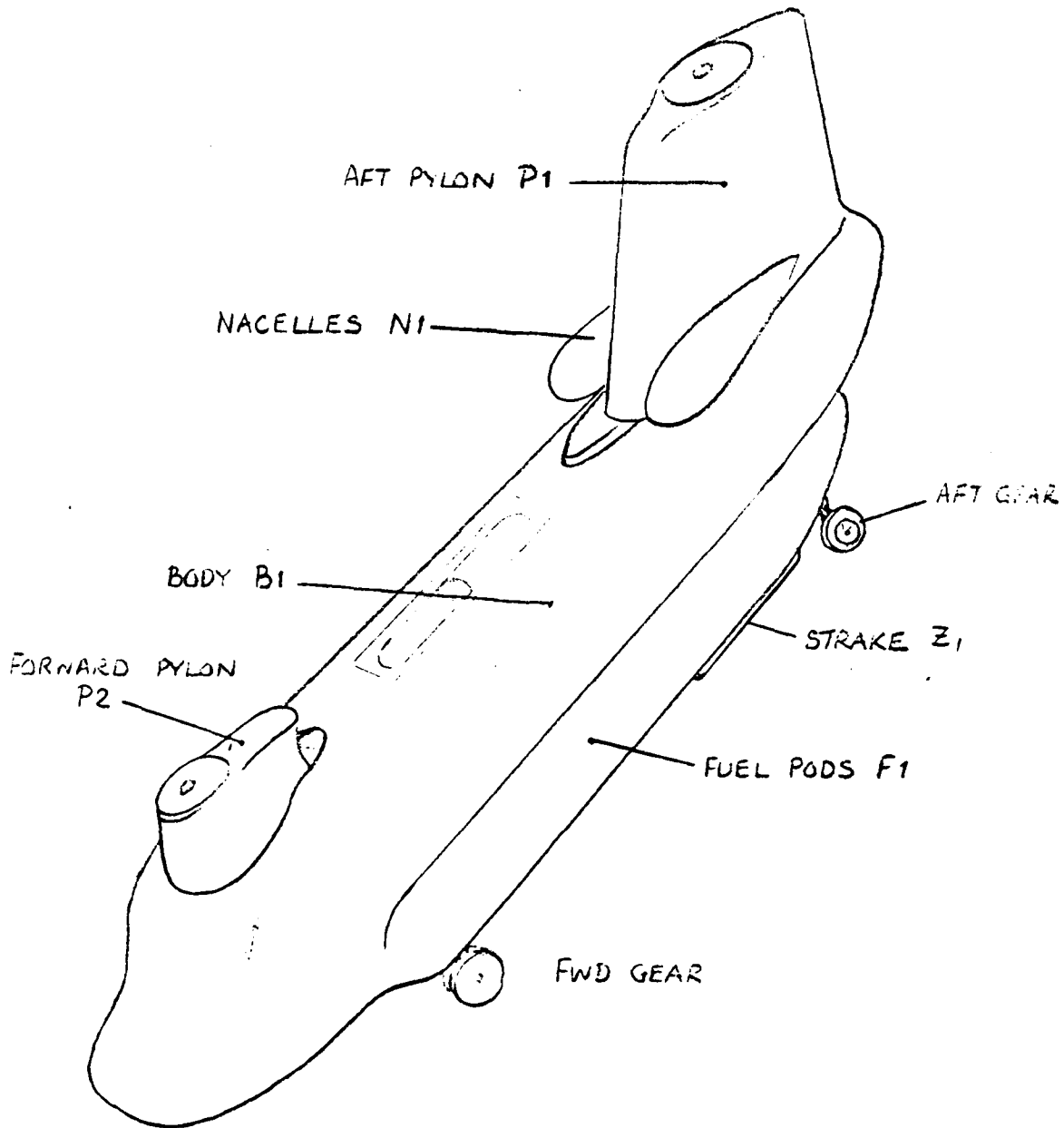

CH-47 BASE CONFIG K1

FIG. 11

UMWT 339

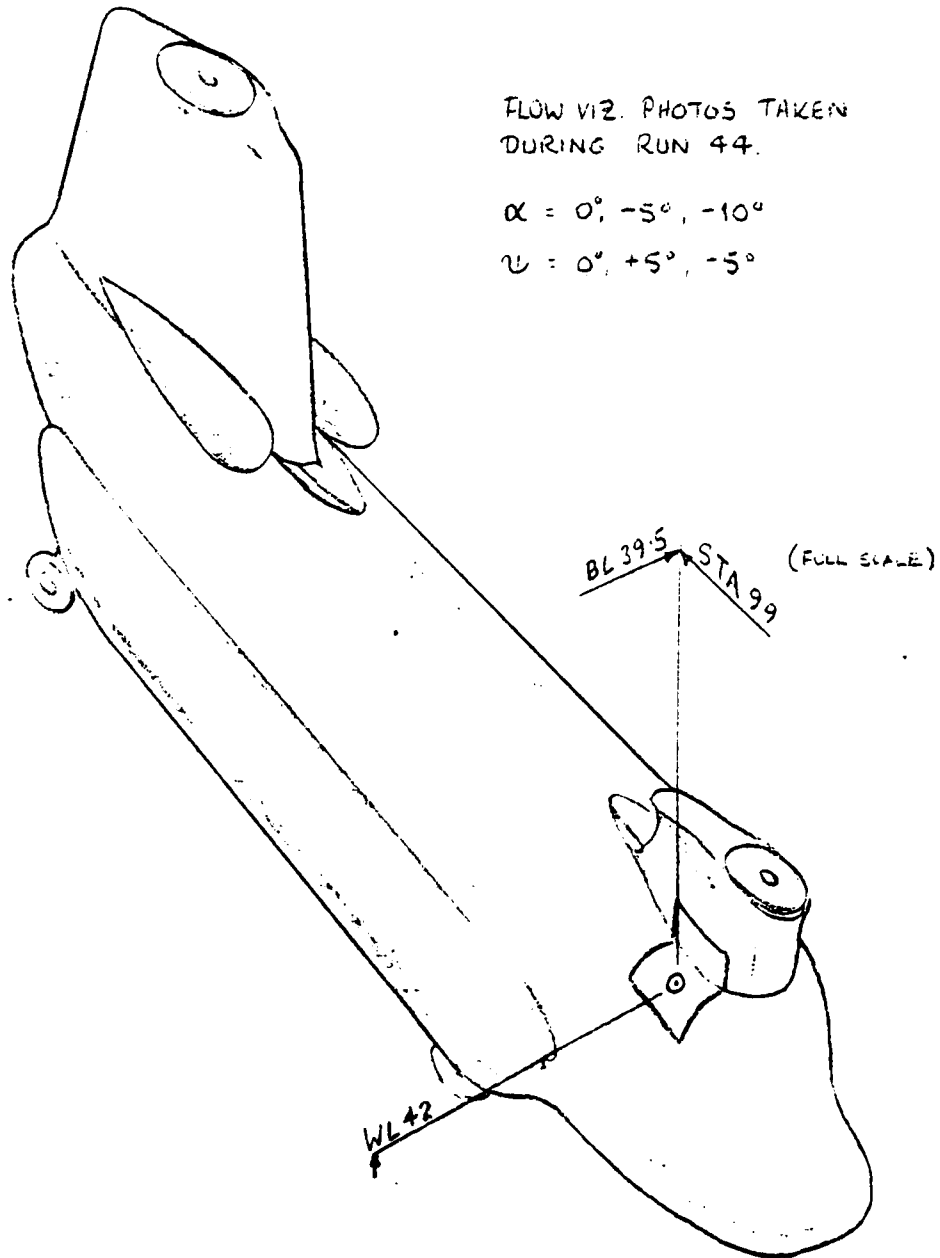

FLOW VIZ. PHOTOS TAKEN
DURING RUN 44.

$\alpha = 0^\circ, -5^\circ, -10^\circ$

$\psi = 0^\circ, +5^\circ, -5^\circ$

FIG 12

LOCATION OF TUFTED
AREA FOR BUMSTEAD RUN

3.2 ADAPTER A

The Snubload Adapter was fabricated per current preliminary design. Construction was of wood and aluminum sheet.

When run alone on the model, the adapter was bolted to the fuselage through the strut holes, which were counterbored to suit this configuration, and also mounting the Gondola.

For carrying the Milvan on the Adapter, the knurled short struts were used. The Milvan was clamped to the struts with the corner locating pins engaged and locked, forming a solid assembly with the Adapter snubbed to the landing gear, forward and aft.

Use of the struts for mounting the assembly also made it possible to vary the adapter-to-fuselage undersurface gaps and load pitch angle relative to the rotorcraft.

A1

Complete Adapter as shown, with guide rods and forward landing gear pads.

Run in basic snubbed position.

UMWT 839

ADAPTER A
BASIC DIMENSIONS

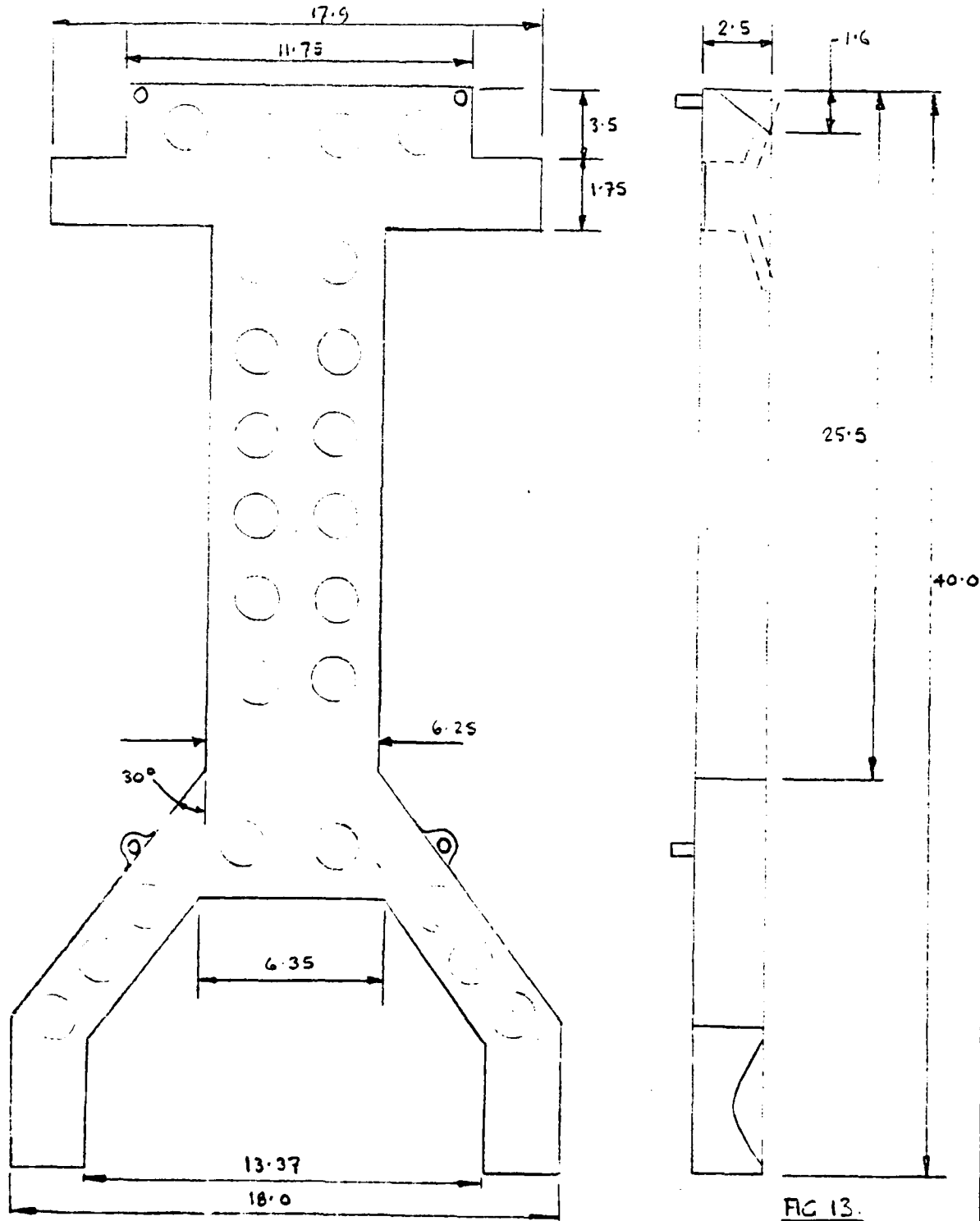
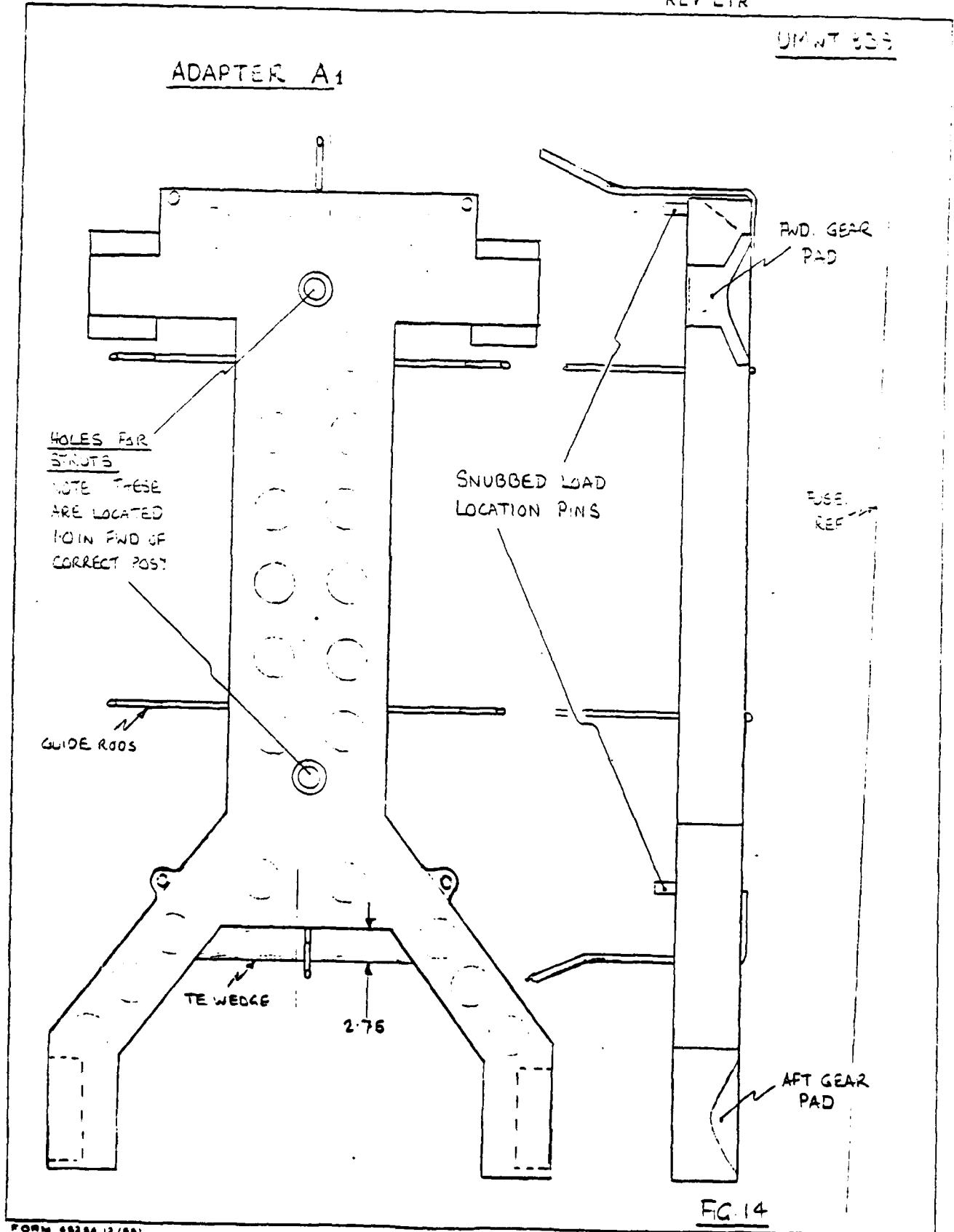

FIG 13.

UNIT 333

ADAPTER A1



Al.1

Complete Adapter with Milvan installed, snubbed to fwd. and aft gear. The leading edge wedge was removed and the vane V₁ placed in position as shown.

(V₁) The Vane had a chord of 3.5 in. and span of 12.0 in. to extend the entire width of the adapter front. It was positioned such that the trailing edge was midway between the adapter and the fuselage undersurface at an incidence (Ref. to model upright) of -10° .

Al.1 run in basic snubbed position.

2147 839

ADAPTER A1-1

VANE 7/1

LEADING EDGE SECTION
REMOVED

((MILVAN))

FUSE
REF

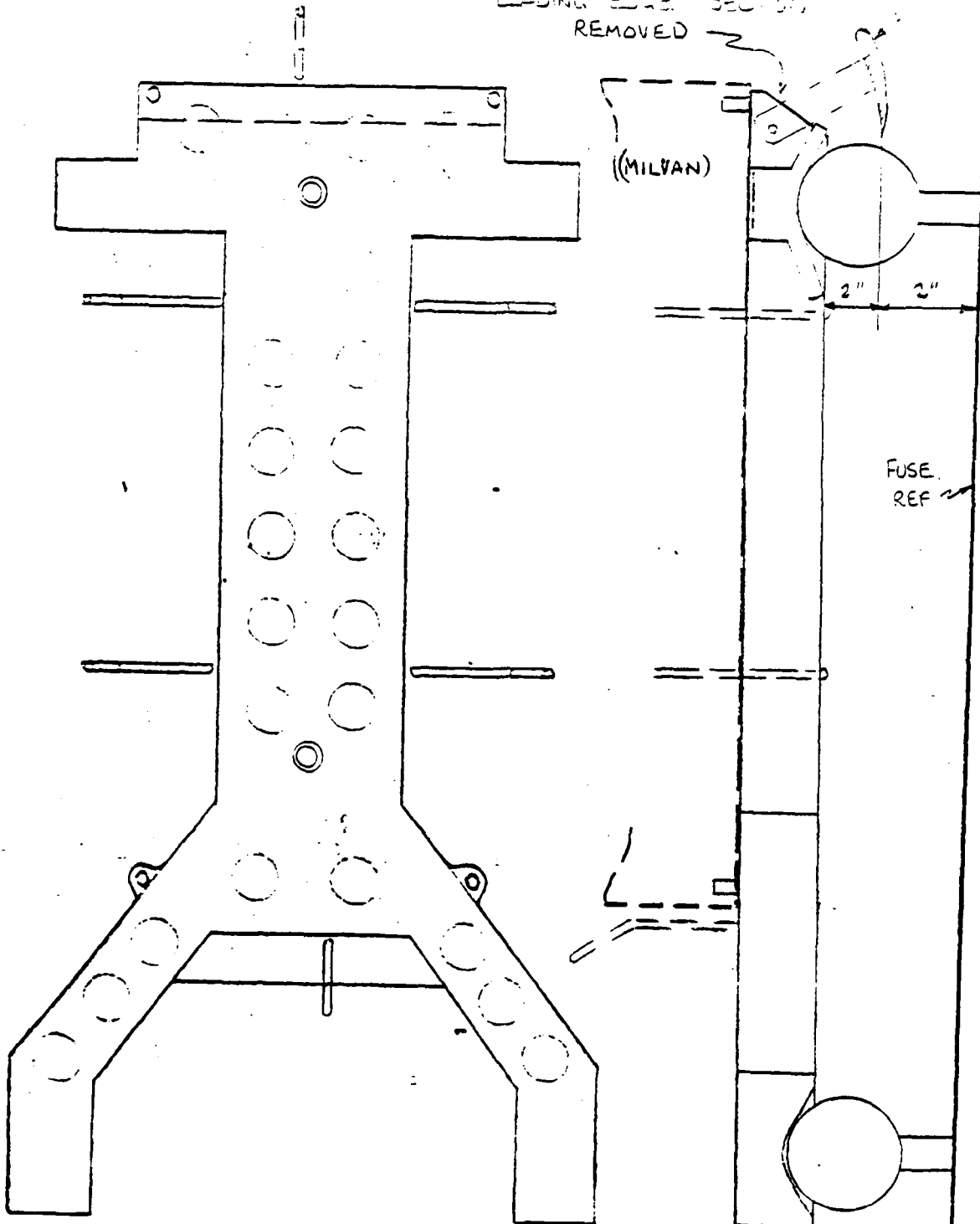
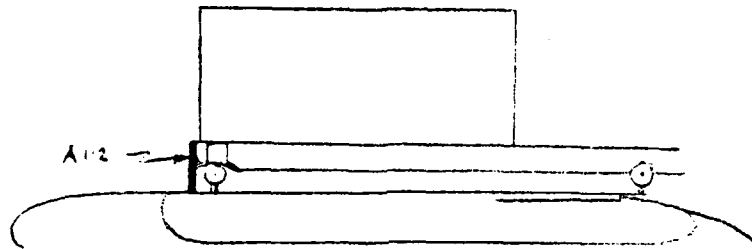

FIG. 15.

A1.2

A1.1 Adapter with a solid full span air dam attached to the adapter leading edge and extending to the fuselage undersurface. This provided complete blockage of the Milvan/Adapter to fuselage gap.

Run in basic snubbed position.



A1.3, 1.4

A1.1 Adapter with cambering plates attached to a wedge installed inside the trailing edge surface, between the trailing arms. Each was set tangential to the wedge surface as shown below:

Run in basic snubbed position.

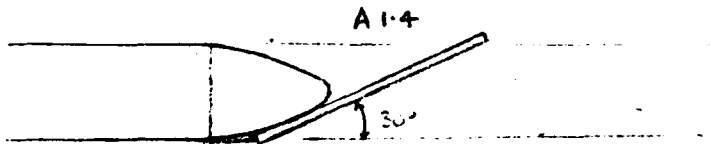
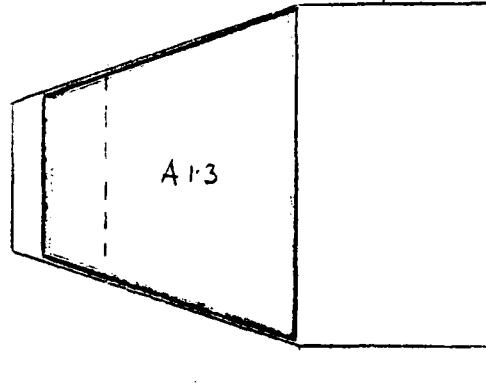
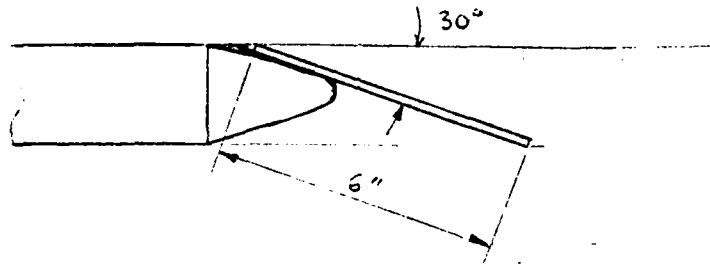

A1.5

A1.1 Adapter with rear gap sealed by an inclined plate as shown.

The leading edge of the plate was taped to the fuselage undersurface and the trailing edge fastened between the adapter arms at the aftermost extremity.

Run in basic snubbed position.

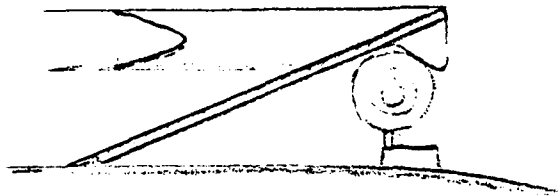

A2.1

A1.1 Adapter with filler blocks of solid balsa inserted both sides as shown. These blocks extended the solid edges of the adapter out to flush with the sides of the Milvan. They were trimmed at the forward end to fit tightly around the fwd. landing gear pads.

Run in basic snubbed position.

A2.2

As A1.1 with guide rods removed.

Run in basic snubbed position.

DMAT 339

ADAPTER A 2-1

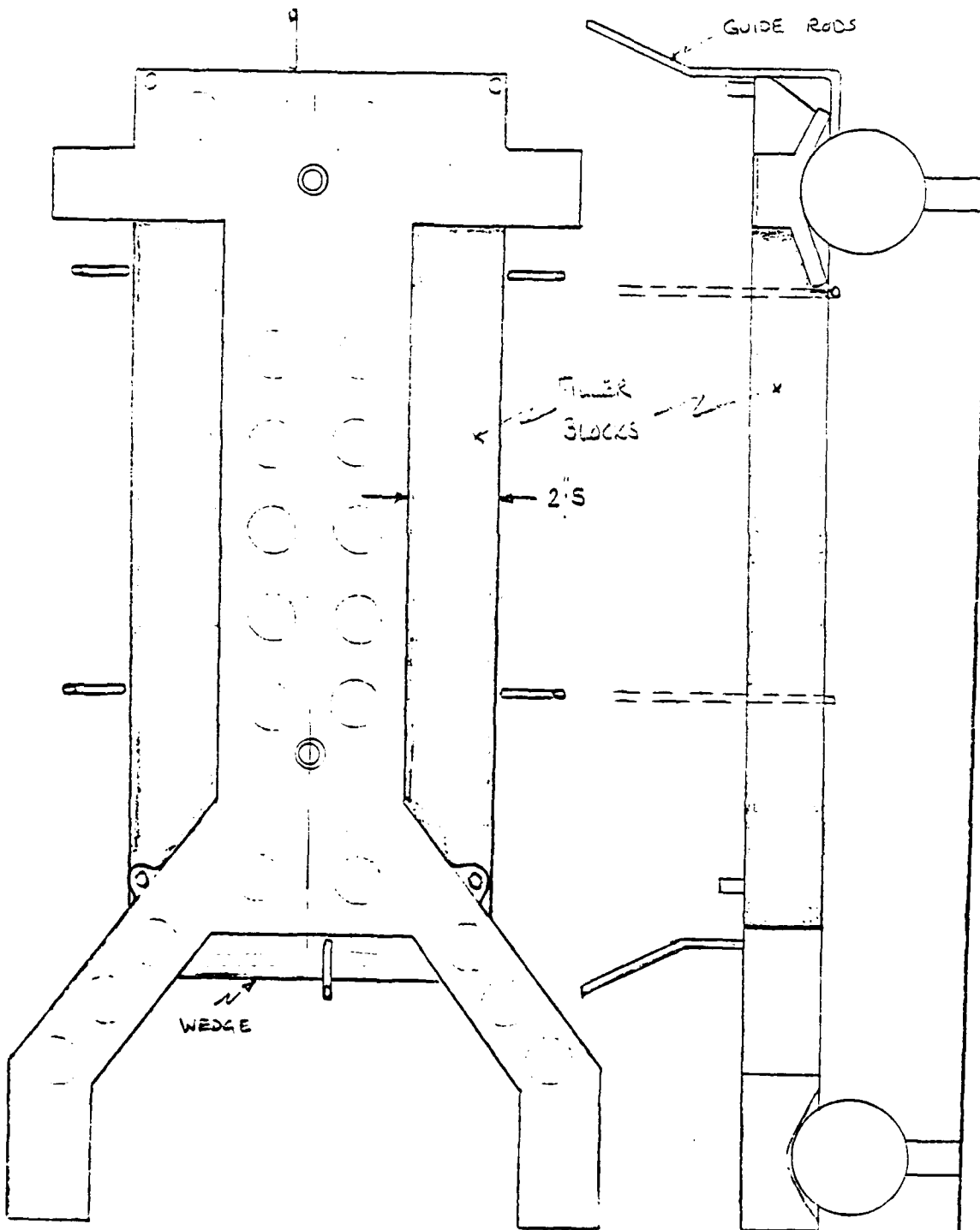

FIG. 16

A3.1

A2.2 Adapter with fully faired surfaces:

Leading edge rounded

Fairings fore and aft of the landing gear pads

Fairings forward and aft of trailing arms.

Aft extremities left blunt

All lightening holes taped over

Run basic snubbed position.

A3.2

As A3.1 but with wider fairings between trailing arms; trailing edge blunted 0.25 in.

Aft end of adapter moved away from fuselage to increase gap @ aft landing gear to 4.425 in, which sets the adapter and Milvan at an angle of $+1.75^{\circ}$ relative to fuselage.

UNIT 839

ADAPTER A 3-1

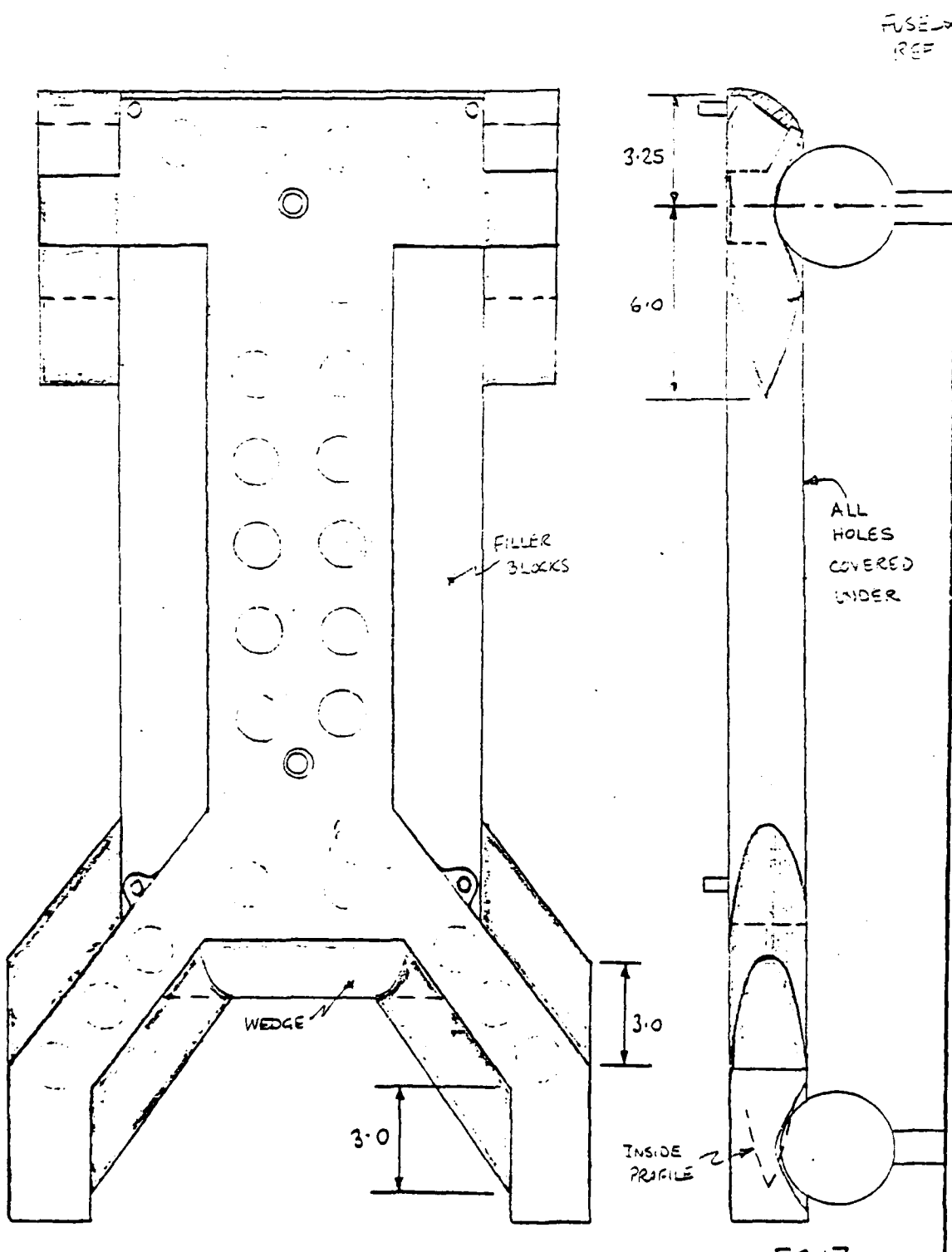

A3.2 → A3.7

The A3.2 adapter was set for various gaps fore and aft, giving different angles to fuselage datum:

Config.	Fwd L/G	30 In. Aft	Angle to Fuse
A3.2	3.50	4.425	+1.75
A3.3	3.50	3.50	0
A3.4	3.50	3.24	-0.5
(0.75 aft gear wheels to well clearance, upper surface to axle centerline 1.25 in.)			
A3.5	2.25	3.70	+2.0
A3.6	2.25	2.47	+0.42
A3.7	2.25	3.13	+1.58

A3.7

Fully faired adapter as A3.2 with aft end separated from landing gear and faired as shown.

A3.5, 3.6 and 3.7 have fwd gear wheels snubbed against adapter surface plate (pad removed) to close fwd gap.

Adapter is moved away from aft gear such that tire edge was at the level of the adapter upper surface. The fwd & aft fairings were modified to suit.

ADAPTER A 3-2

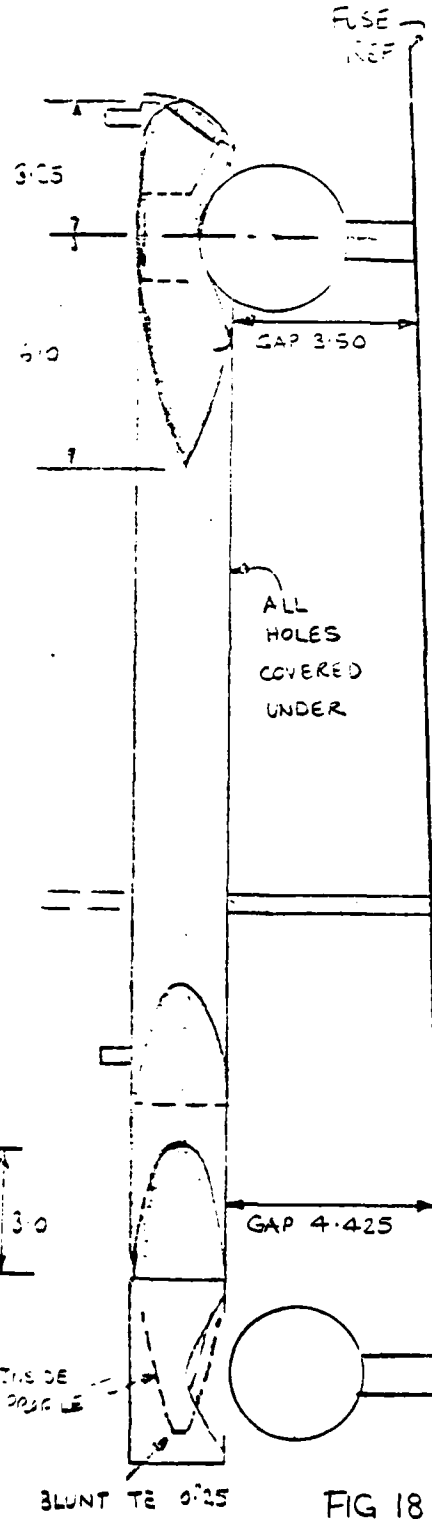
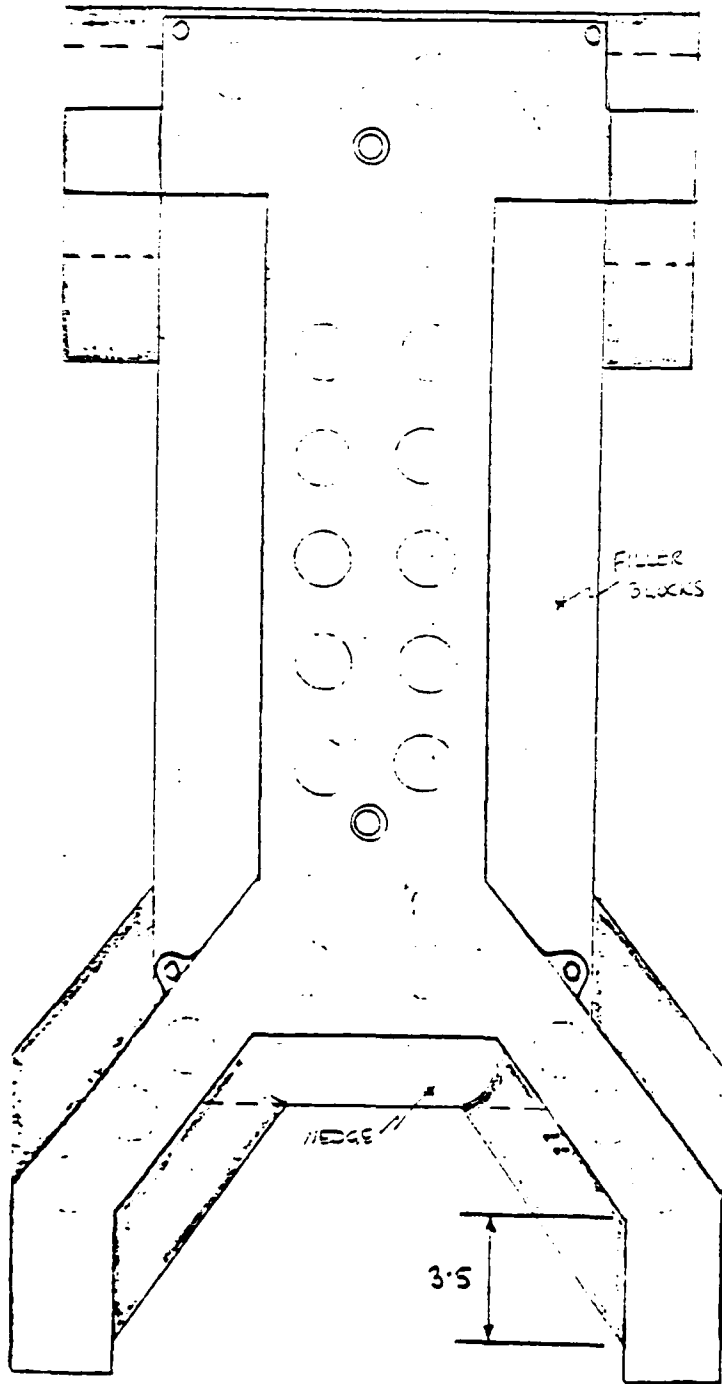

UMWT 839

ADAPTER A 3-7

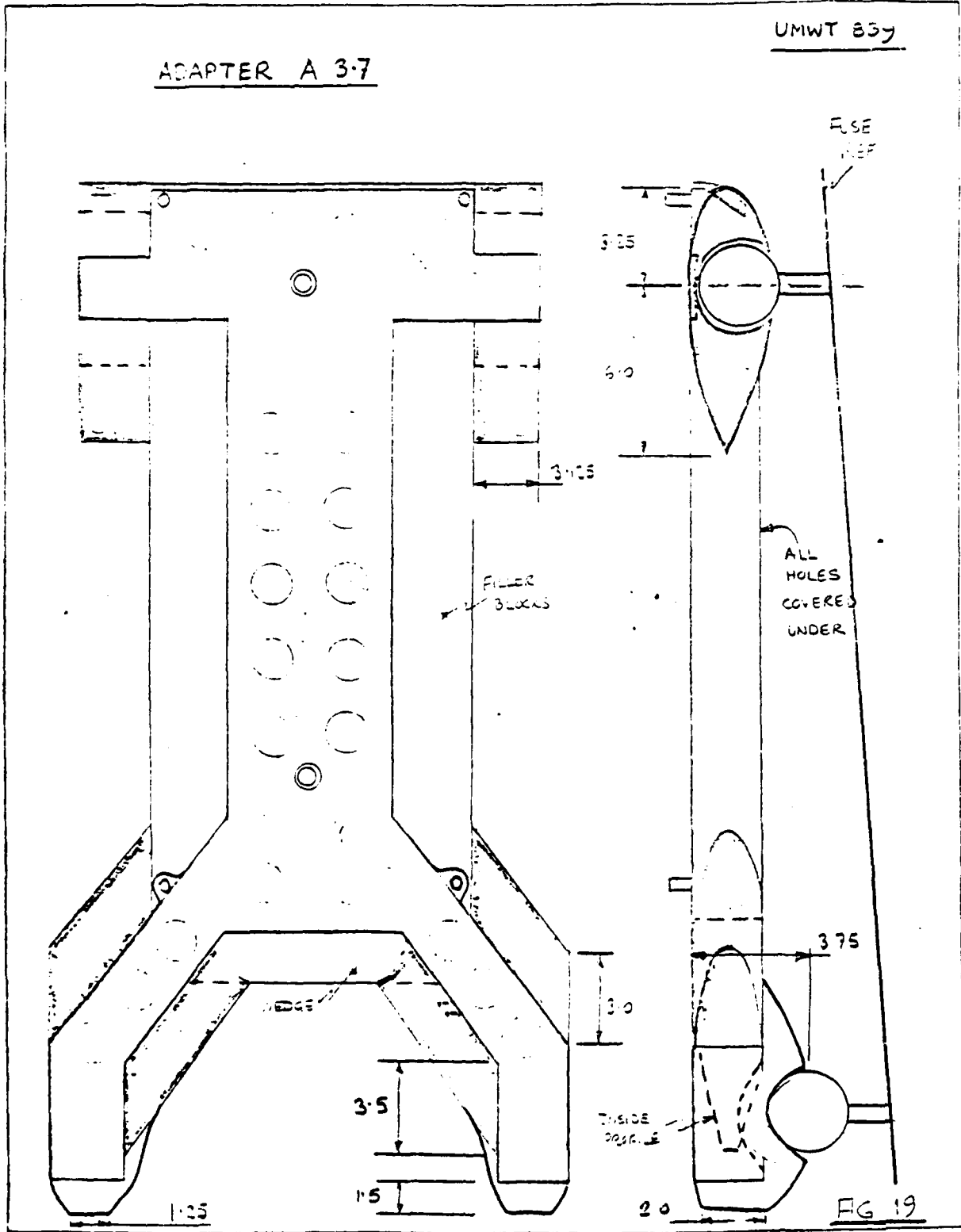

FORM 44-2 2 661

A3.7 Breakdown:

- A3.7.1 A3.7 with the guide rods installed. Rods could not be fitted in the forward side positions due to interference with the forward landing gear fairings.
- A3.7.2 A3.7 with the inner aft fairings removed (between arms); guide rods off.
- A3.7.3 A3.7.2 with fairings removed from front of trailing arms.
- A3.7.4 A3.7.3 with front part (to wheel centerline) of forward gear fairing removed.
- A3.7.5 A3.7.4 with aft portion of forward gear fairing removed.
- A3.7.6 A3.7.5 with nose rounding radius removed (leaving angled surface).
- A3.7.7 A3.7.6 with filler blocks removed and holes untaped.

A4.0

Adapter built up from best features of A3.7
breakdown. This configuration embodied:

Milvan/adapter to fuselage angle : $+0.98^{\circ}$,
Nose rounding radius,
Lowered plate on forward gear with leading edge build-up,
Side guide rods with tubes faired to adapter upper
surface,
Holes taped over,
Filler blocks along sides,
Wedge in trailing edge between arms,
Fairing built up around aft gear.

UNIT 239

ADAPTER A4.0

FUSE
REF.

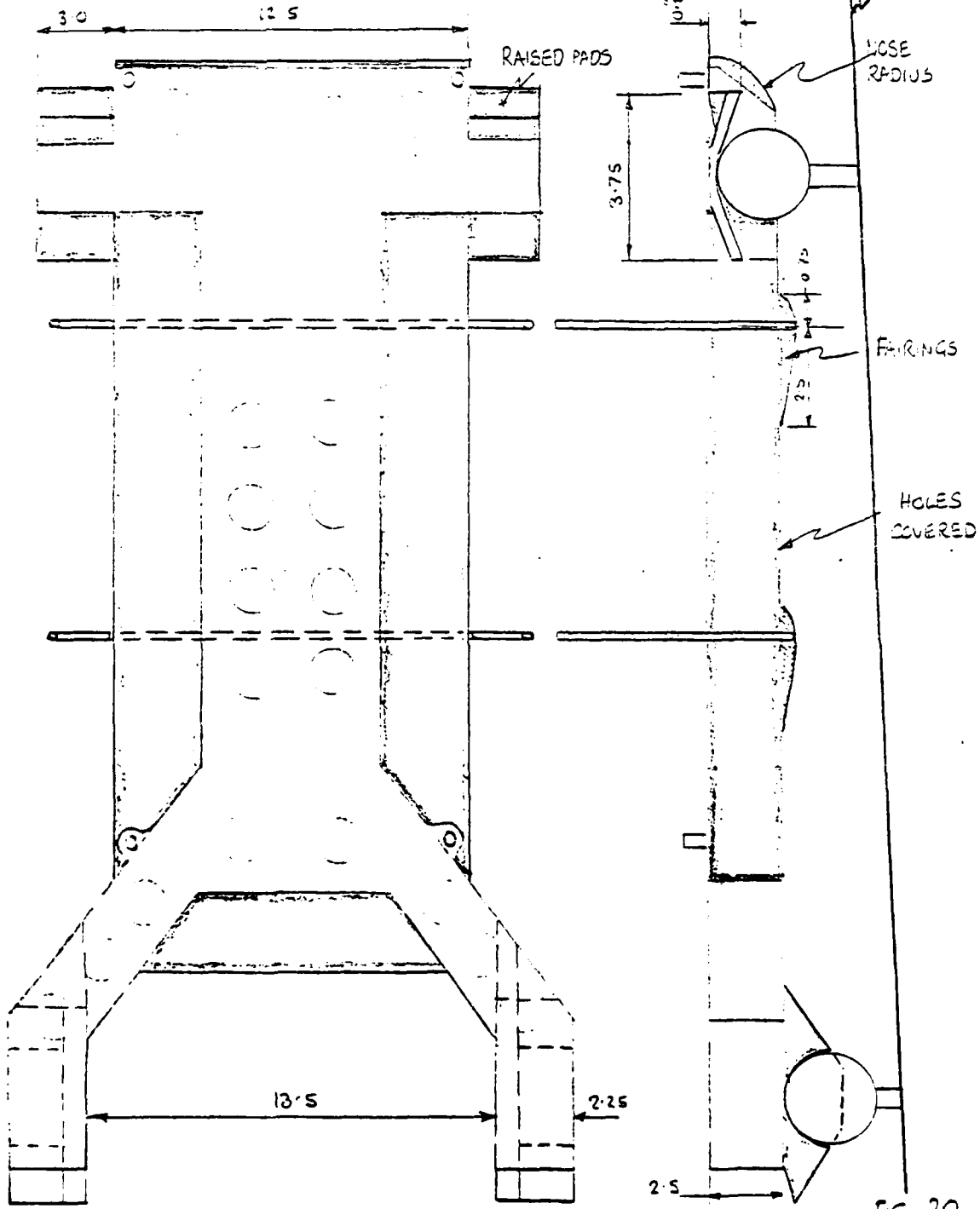

A4.1

A4.0 with trailing arms cut as shown to simulate arms installed at an angle to suit the revised position over aft gear.

A4.1.1 As A4.1 with wedge between trailing arms removed.

A4.1.2 As A4.1.1 with fairings on upper surface, over guide rods, removed.

UNIT 239

ADAPTER A4.1

FUSE.
REF.

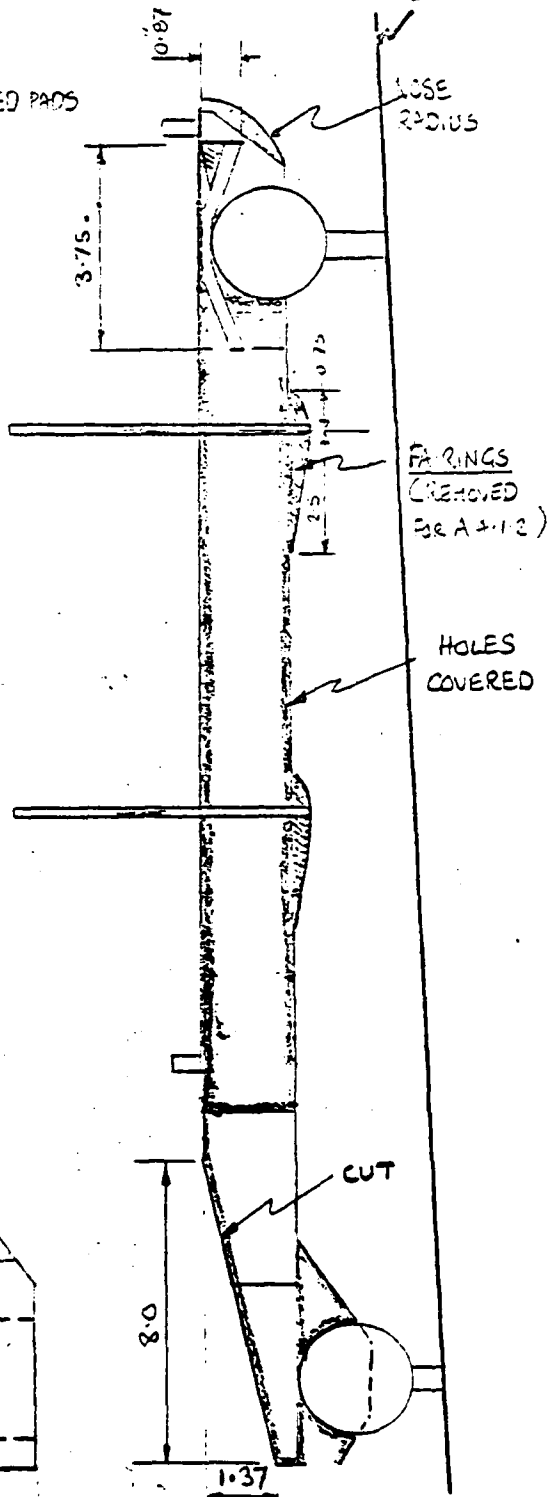
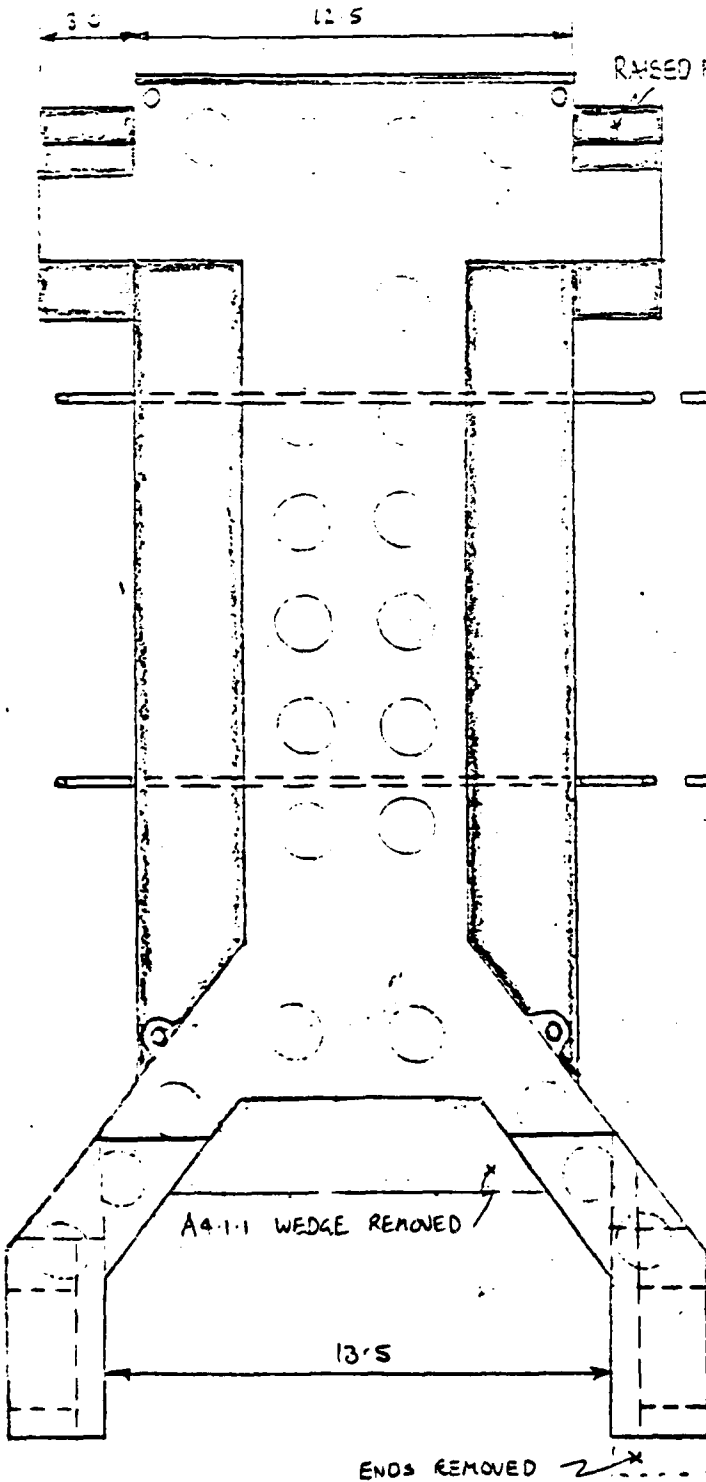

3.3 Gondola G1

The G1 gondola consisted of an aluminum structure frame, floored with fine wire mesh. Overall dimensions were:

Height:	12.0 In.
Width:	12.0 In.
Length:	30.0 In.

The FARRP Load contained in G1, ammunition box and cylindrical containers were fabricated of polystyrene and bolted through the wire mesh to light baseplates.

The gondola was held below the fuselage lower surface in a simulated sling load position with the struts S2. Bracing wires (0.020 dia. music wire) attached the four corners of the gondola to the model fuselage.

Gondola G2

As G1, but empty.

DRAWING

GONDOLA G 1

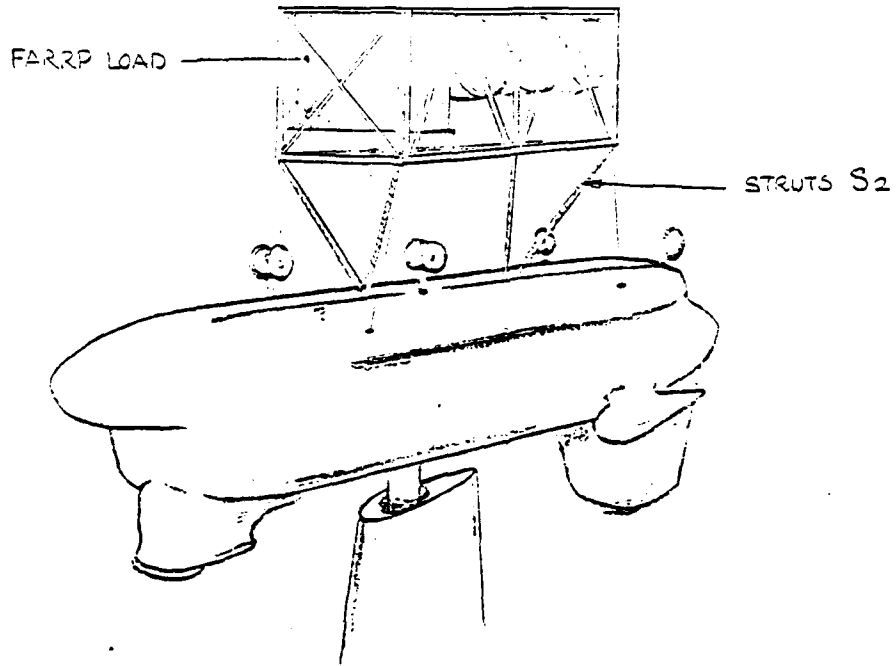

GONDOLA G 2

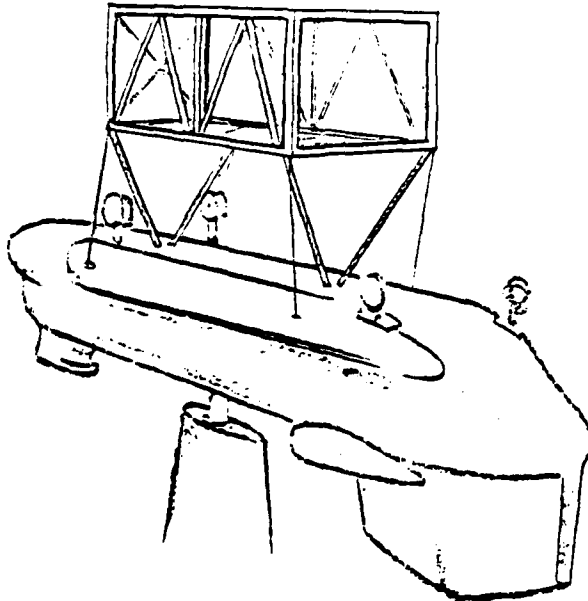

FIG 22

3.4 Milvan M1

The Milvan model was constructed of aluminum and plywood. Contained internally were tubing sleeves into which fitted the supporting struts S1. The box was locked to the struts by means of socket head screws in brazed fixtures on the tubes. By this means the height of the box on the struts could be varied. Correct testing heights were set by inserting plywood formers between the box and the fuselage lower surface.

At the rear of the Milvan, five (5) static pressure ports were installed as shown. Each was plumbed to tubes which were taped to the rear of the aft strut. The tubes entered the model through a small hole aft of the strut, from where they were led through the model and down the support strut to the sampling instrumentation (scanivalve). Also shown in the diagram is a tube taped to the ramp which sampled static pressure in that location. Pressure ports (to measure the model base pressures) were installed to help assess the adequacy of blockage corrections.

UNIT 339

MILAN, MI
MOUNTED ON STOLTS S¹³

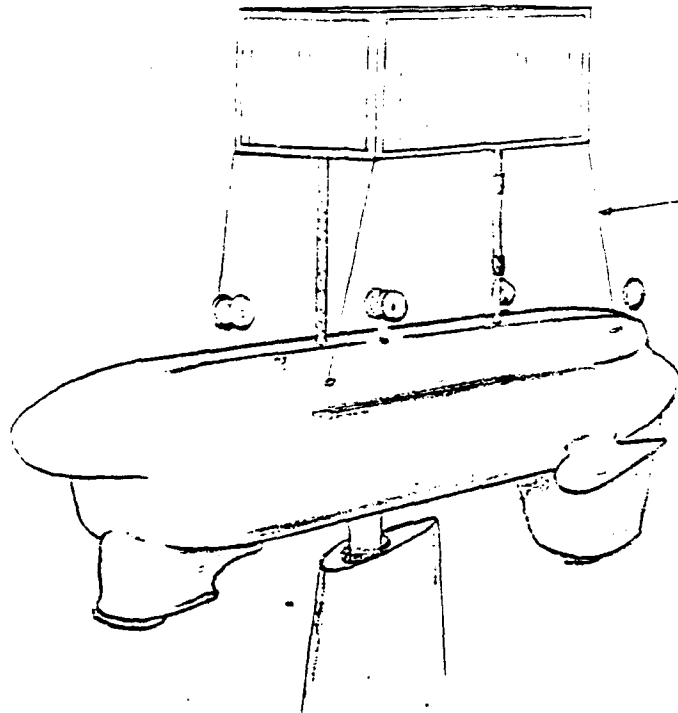

BRACING WIRES 010209

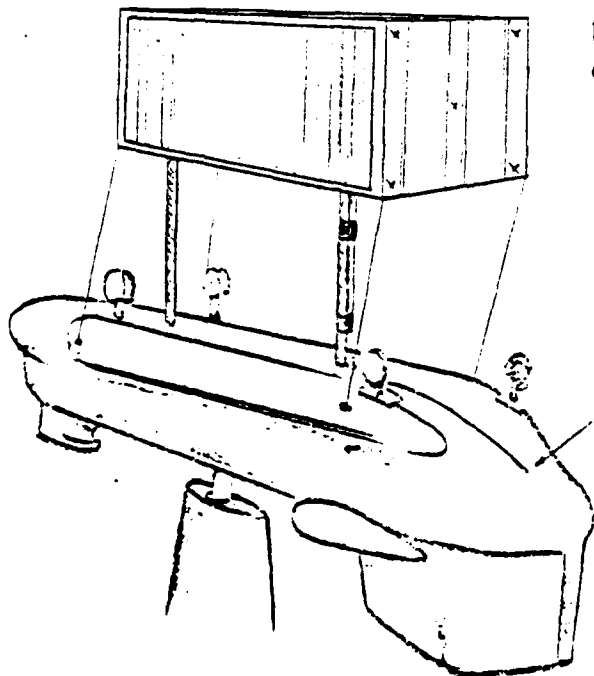

PRESSURE PORTS IN REAR
OF BOX (5)

PRESSURE PORT 26
ON RAMP 4

FIG. 23

DRAW 839

MILVAN 111 ATTACHED TO FUSelage
UNDERSIDE FOR RUNS 10 11

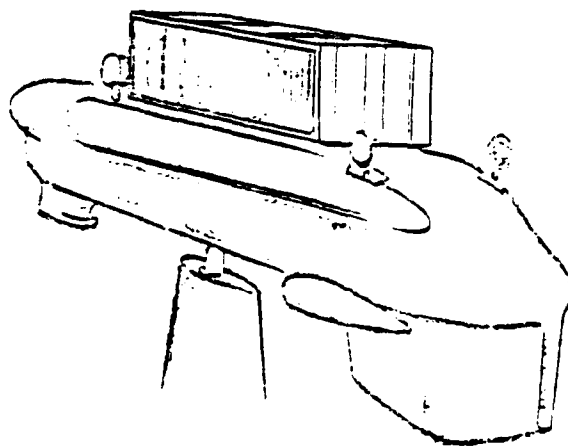
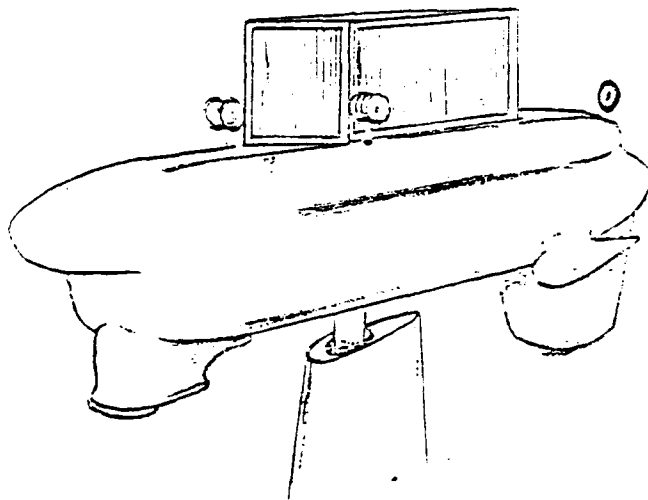

FIG 24

3.5 Struts Sl^{XX}

Struts were used for holding the Milvan at various distances from fuselage underside. Superscript indicates strut exposed length.

Lengths provided: 5.0 in
 10.0 in
 15.0 in

Struts were fabricated of 0.5 in dia. steel rod, heavily knurled to reduce Reynolds No. effects. Knurling depth was approx. 0.015 in.

When run alone, 0.020 in. dia. music wires were strung tightly as shown so that the strut tare thus determined would also include the bracing wire drag tare.

UMWT 839

STRUTS 31⁵

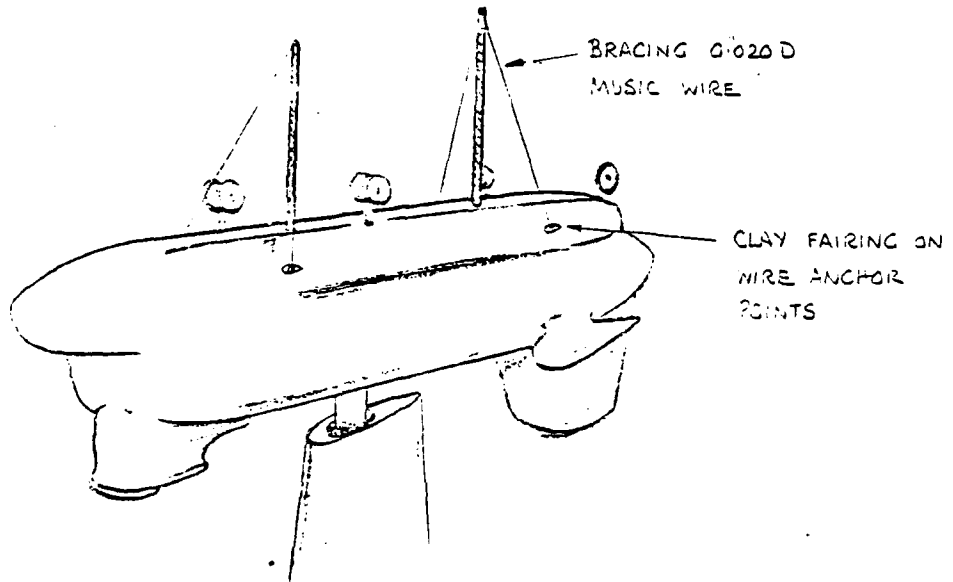

SET UP FOR STRUT TARE DETERMINATION
(INCLUDES TARE OF BRACING WIRES).

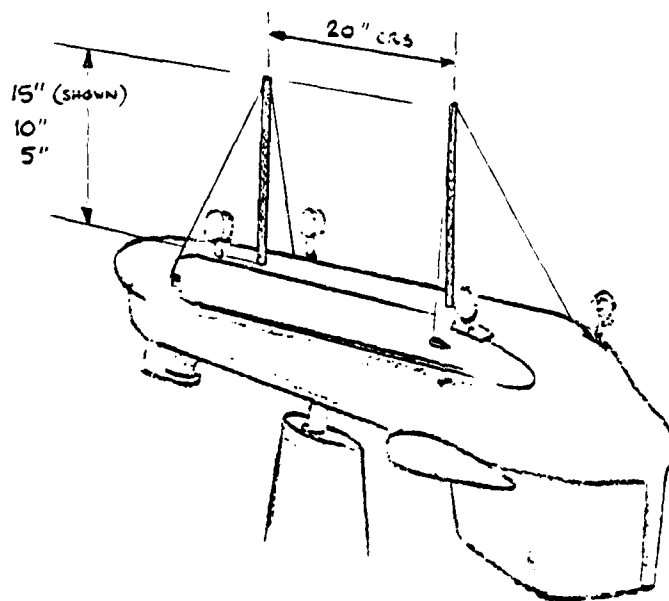

FIG. 25

Struts S2

These struts were used to represent slings for the Gondola. They were fabricated from 0.375 in dia. steel rod, heavily knurled (0.15 deep).

Each strut fitted into a hole in the corner of the gondola frame, being bent to an angle of 35° to give the required 12 in. spread. The struts attached to the model fuselage by means of taped holes and were braced with 0.20 in. dia. music wire as shown.

DRAW 339

STRUTS S2

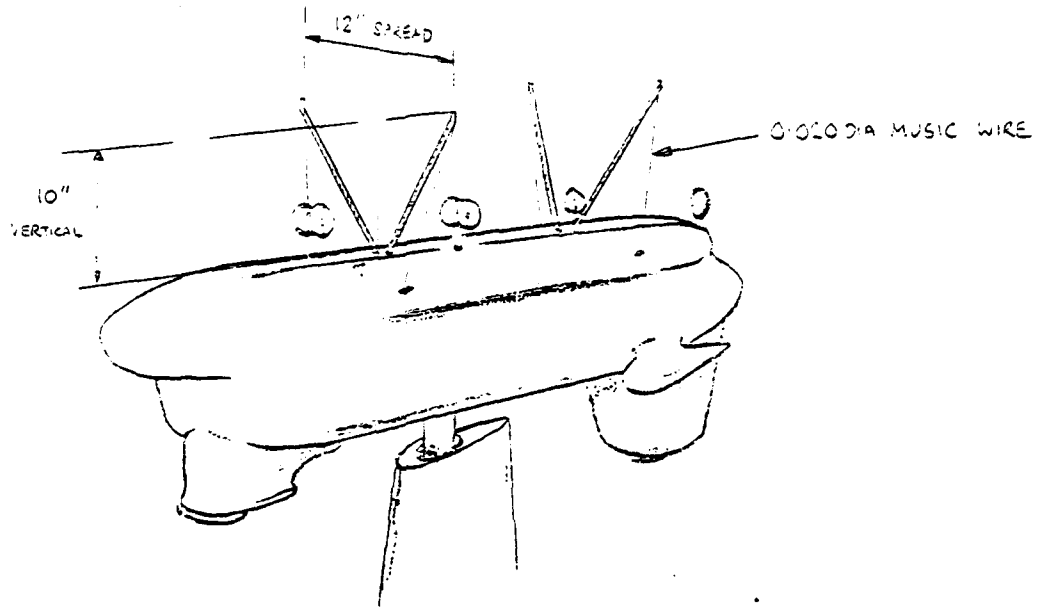

SET UP FOR STRUT TARE DETERMINATION
(INCLUDING TARE OF BRACING WIRES)

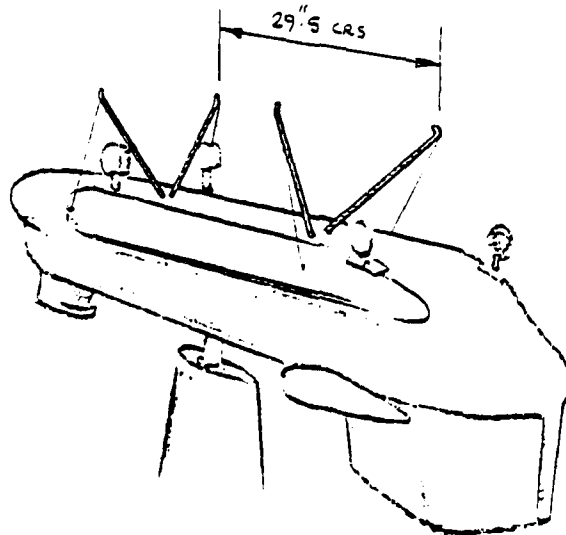

FIG 26

3.6 Transition Strips TS1

To avoid possible Reynolds No. effects, transition strips were applied to all model surfaces that could be susceptible:

- Forward Pylon
- Nose
- Windshield and crown
- Fuel pods
- Landing gear struts and wheels
- Nacelles
- Aft Pylon

Grit used was 0.0055 in. average dia. carborundum. Strips were made 0.5 in. wide and the grit bonded using Polaroid film fixative. Approx. grit density was 30:1 (space of 30 diameters between particles).

A run was made at the beginning of the test program to ascertain a reasonable dynamic pressure at which test runs could be made. Freedom from Reynolds No. effects is shown by a constant low drag value. Results are plotted, below:

TS TRANSITION STRIPS

UNIT 889

ALL DIMENSIONS ARE DISTANCES
AFT FROM SURFACE HIGHLIGHTS.

0.0055 AV. DIA CARBORUNDUM
GRIT USED: STRIPS 0"5 WIDE TYP.

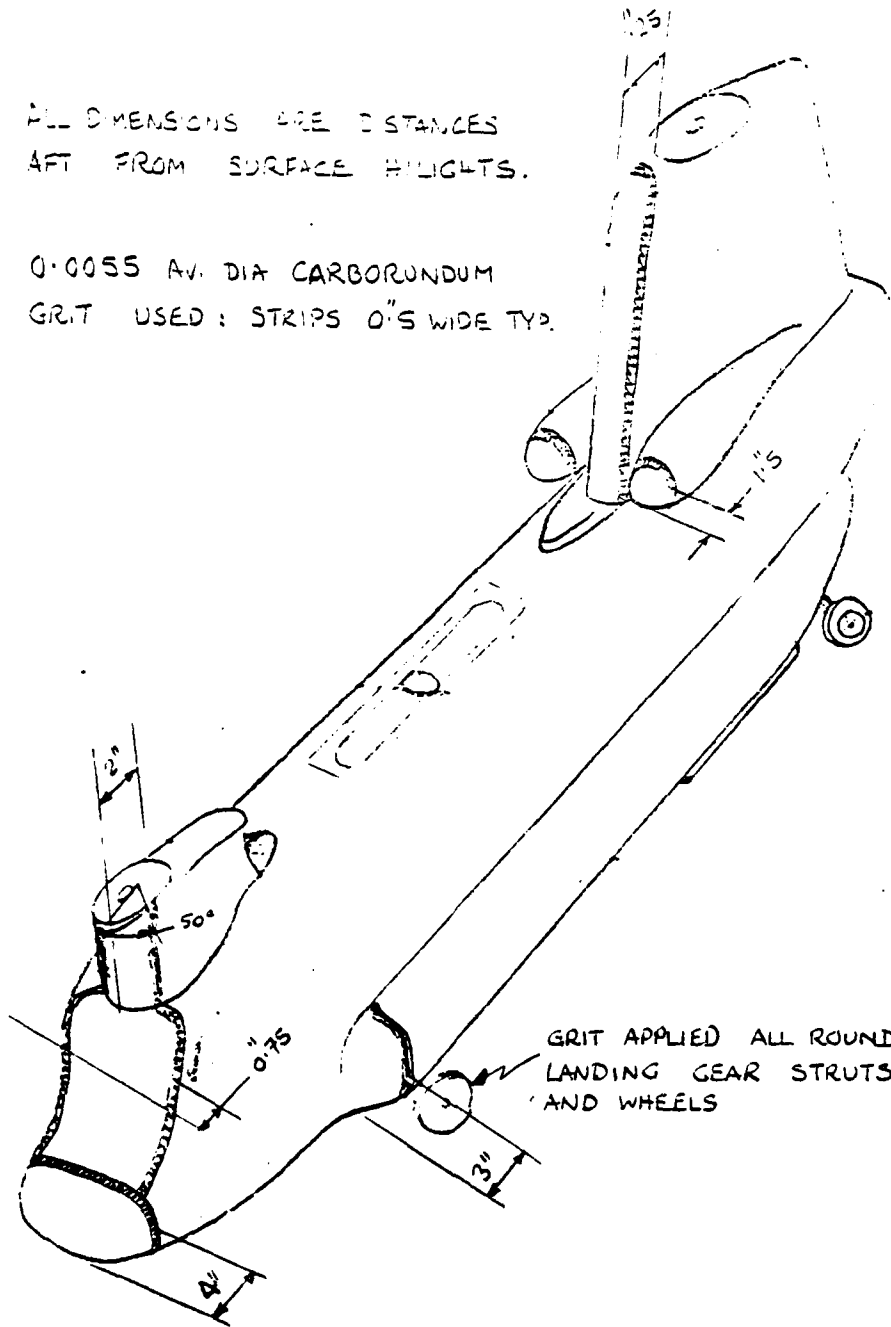

GRIT APPLIED ALL ROUND
LANDING GEAR STRUTS
AND WHEELS

TRANSITION STRIPS TS1

FIG 27

4. INSTRUMENTATIONTunnel Parameters

Tunnel dynamic pressure was obtained by means of a sensitive transducer which measured the pressure differential between bellmouth total pressure probes and working section static pressure.

Section static could be taken from either a ring of ports at the working section entrance or from the 'centerline statics,' a ring of orifices located at the support strut station. Both were sampled for the purposes of assessing the accuracy of the method used for determining blockage corrections.

Also, for this test, a row of static orifices in the roof of the working section were sampled for representative configurations of the model, in order to obtain the pressure signature. (Comparative data were obtained by taking the roof statics' increment with and without the model present.) See Fig. 28, following.

All pressure data were acquired using a scanivalve.

Model Parameters

Model pitch angle was measured by an internal pot, at the pivot point. Yaw angle was acquired from the support strut drive system.

Static pressure orifices on the model were sampled for selected runs, in order to obtain the base pressure coefficients used in blockage correction checks.

Static pressure sampling orifices were located as shown in Fig. 29, following. One orifice in the center of the fuselage ramp was taken as being representative of body wake conditions; the rear surface of the Milvan was pierced in five places, at each corner and in the center, for base pressure measurements.

The table, following the figures, lists pressure sampling on the scanivalve ports.

DIE CASTING CORPORATION - TITANIUM

PLOT 3818R MP DIE CASTING GRAPH PAPER MILLIMETER

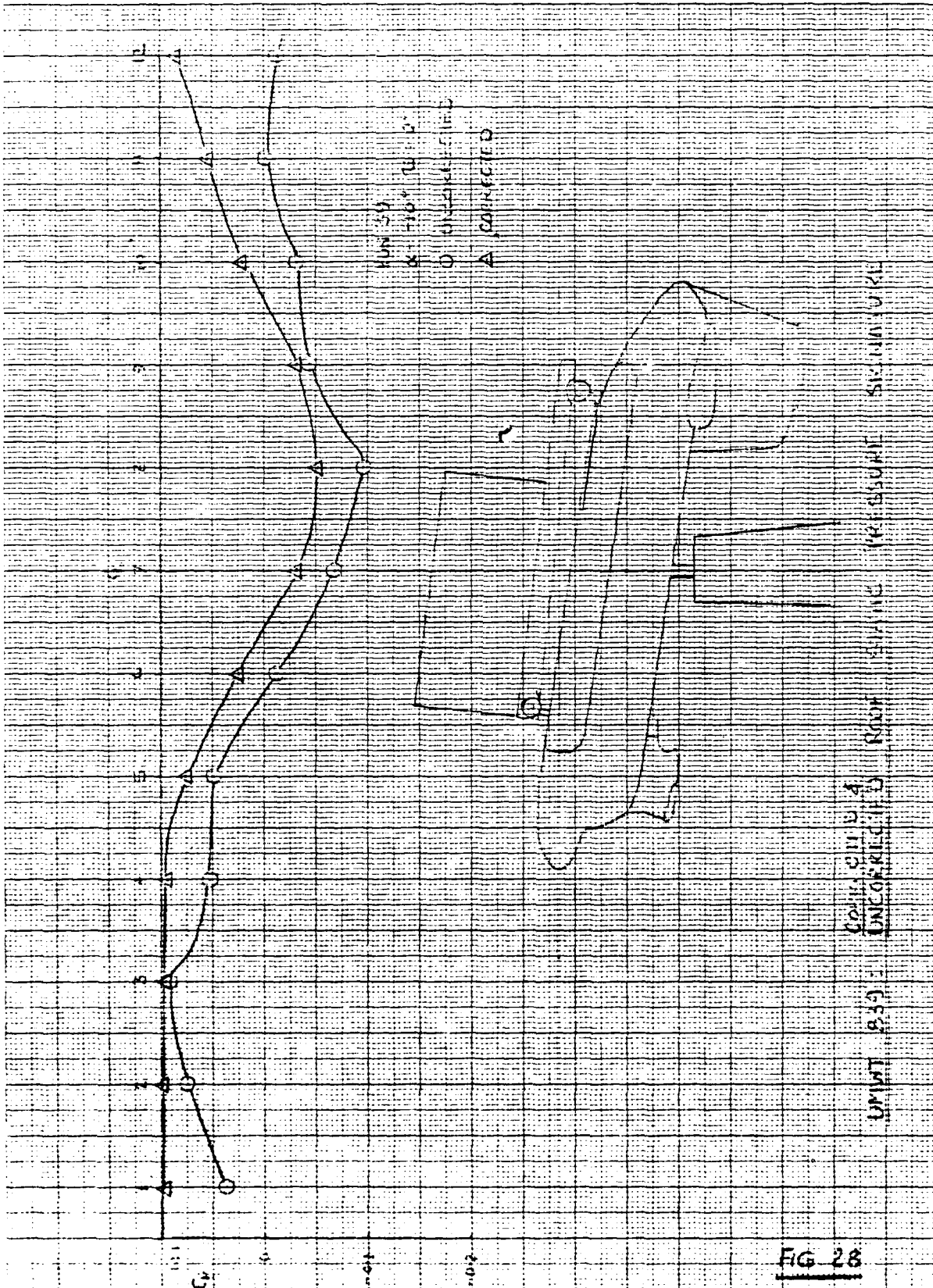

UMWT 839

PRESSURE PORTS LOCATION

TUNNEL STATICS

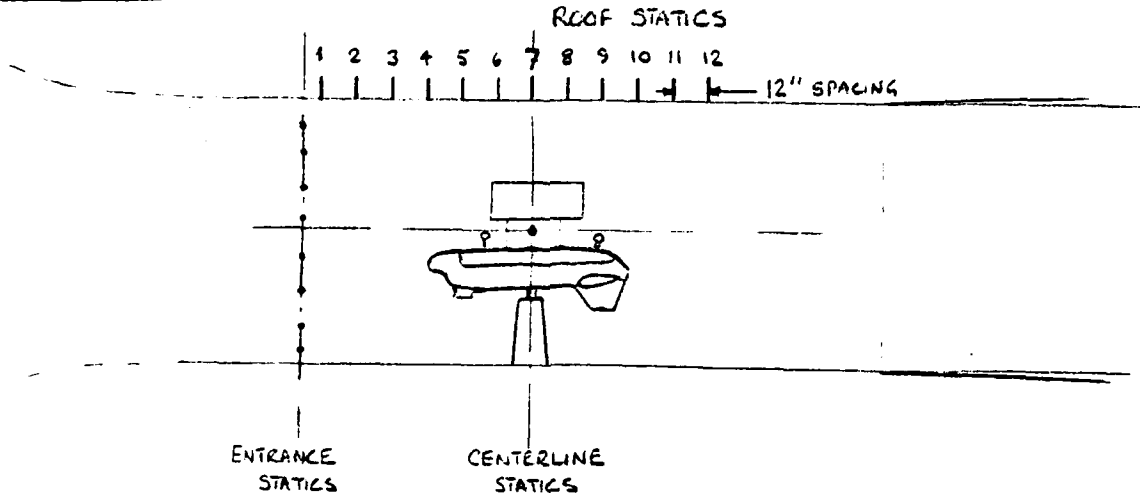

MODEL FUSELAGE

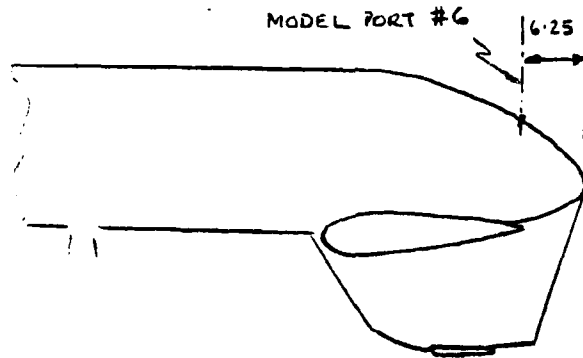

MILVAN REAR

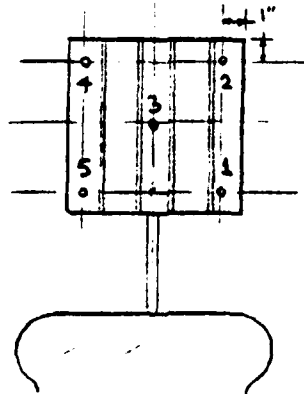

FIG. 29

UMWT 339

SCANIVALVE KEY

PORT	PRESSURE
0	TUNNEL TOTAL PT
1	ENTRANCE STATICS PSE
2	SECTION CENTERLINE STATICS PSW
3	ROOF STATIC Ps1
4	Ps2
5	Ps3
6	Ps4
7	Ps5
8	Ps6
9	Ps7
10	Ps8
11	Ps9
12	Ps10
13	Ps11
14	Ps12
15	(OPEN)
16	MILVAN REAR PSM1
17	PSM2
18	PSM3
19	PSM4
20	PSM5
21	FUSE RAMP PSR (6)

5.0 DATA REDUCTION & CORRECTIONS

Data from the CH-47 Snubload model consisted of 6-component forces and moments, acquired by the external virtual center balance, and pressure data from the tunnel system, tunnel roof statics and model orifices.

- 5.1 6-component data were corrected for aircraft CG by the moment transfers detailed in Fig. 30, following. Parameters were reduced in both wind and body axes to full scale divided by dynamic pressure.

Dynamic pressure used for the data reduction system, was that value sensed from the working section centerline static orifices, at the station of the support strut. This method had been found adequate, in terms of 'built-in' blockage correction for bluff bodies, during previous testing. Further investigation was conducted to assess the accuracy of this method, as detailed in this section.

Model pressure signatures from roof statics are plotted in Figs. 31 - 34.

MOMENT TRANSFER:

UMWT 830

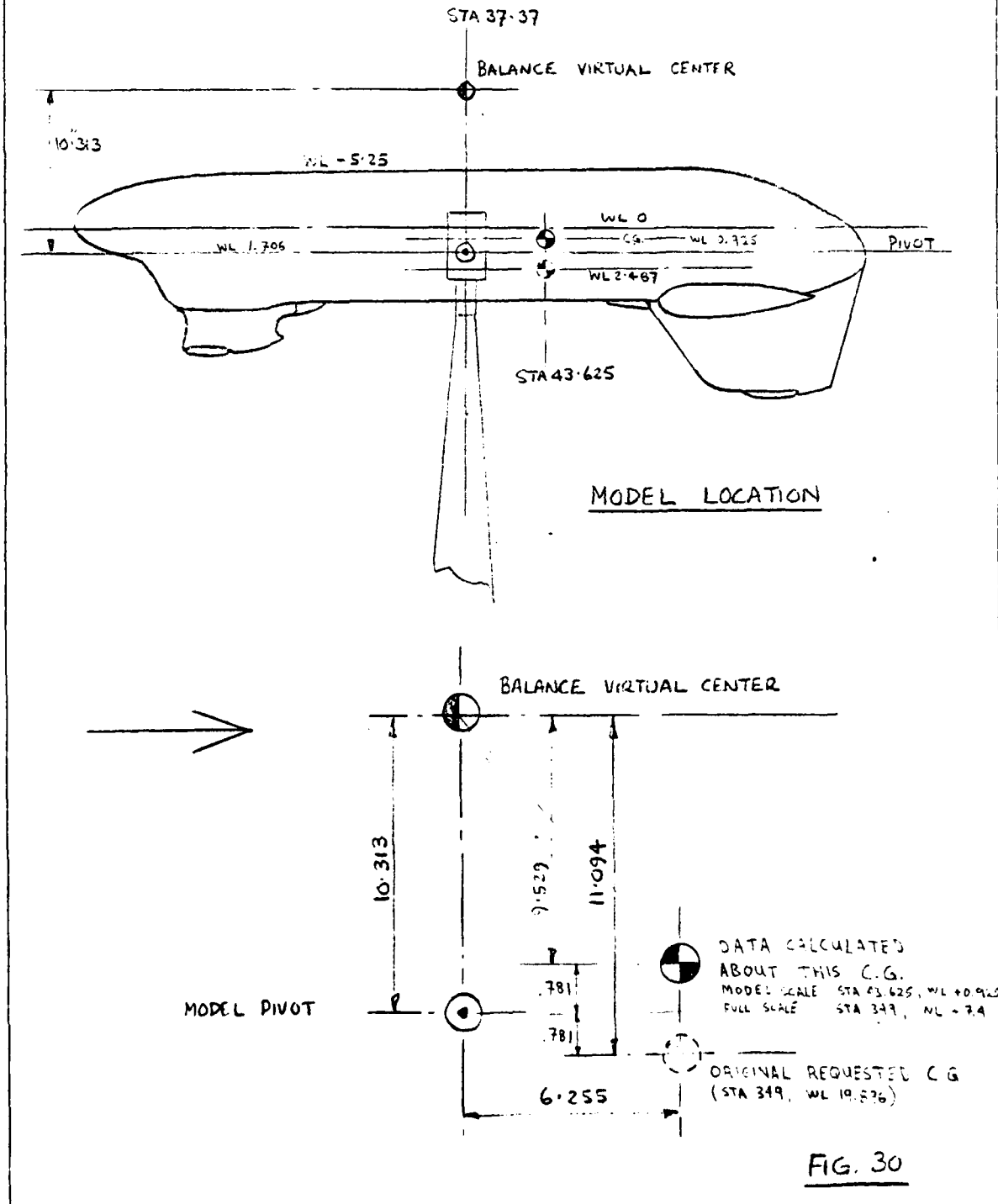

NO. 3-109 M.D. DIEZEL GEN. GRAPHIC PAPER
MADE IN U.S.A.
MILLIMETER

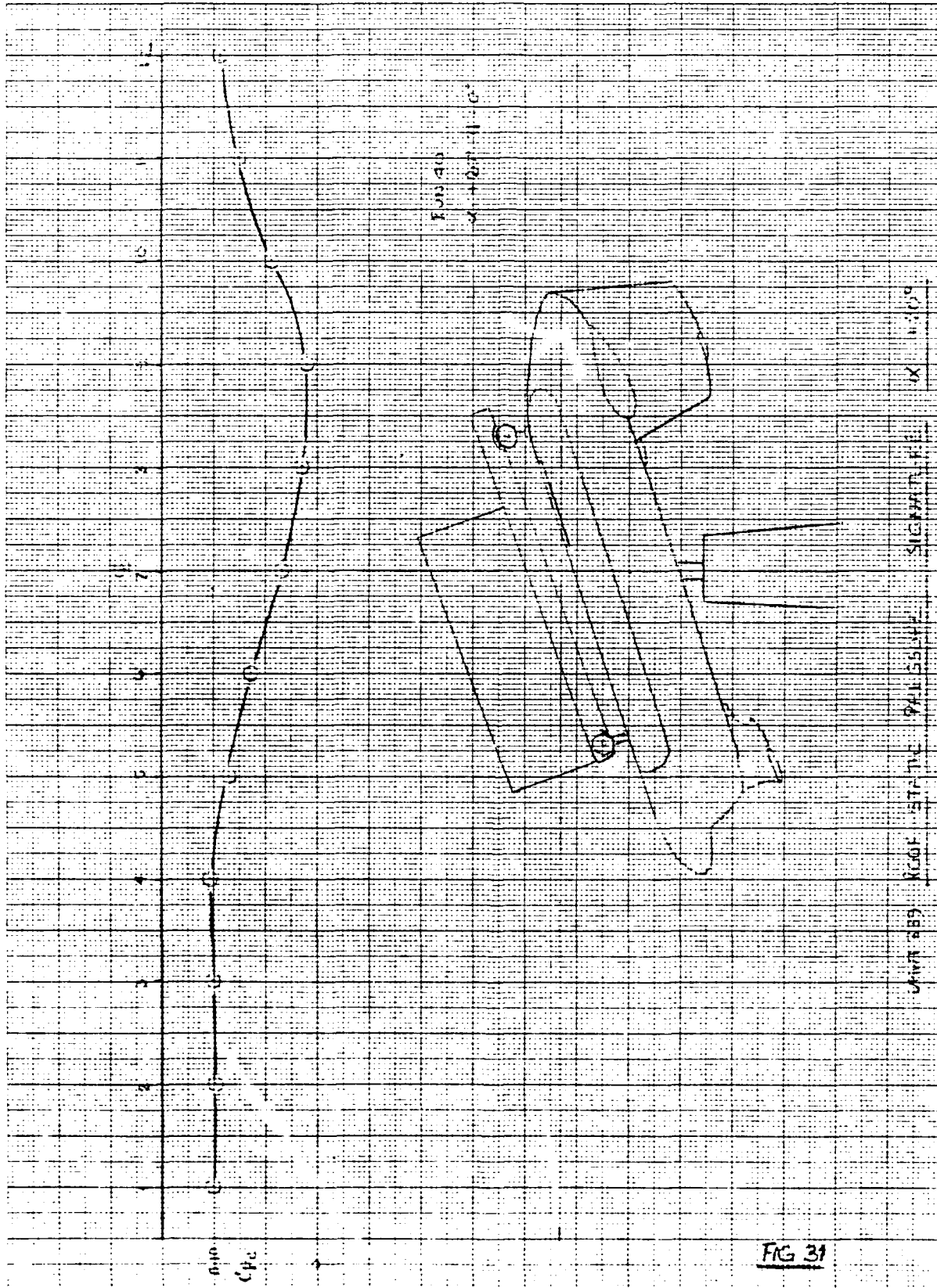

FIG 31

DIETZEN CORPORATION
MADE IN U. S. A.

NO. 1401 MP- DIETZEN GRAPH PAPER
MILLIMETER

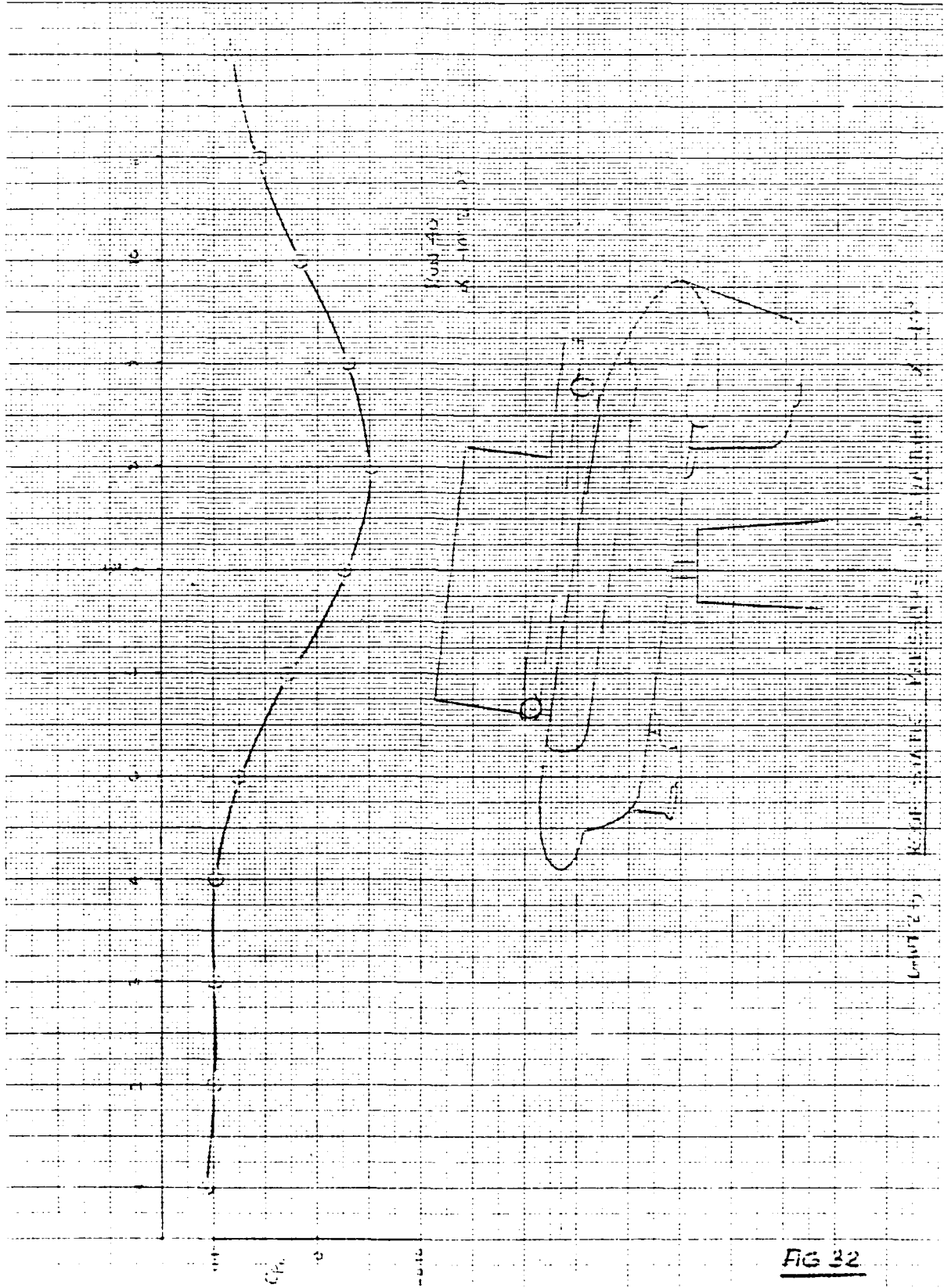

FIG 32

AD-A088 057

BOEING VERTOL CO PHILADELPHIA PA F/8 1/3
DESIGN AND ANALYSIS OF CH-47 EXTERNAL CARGO HANDLING SYSTEM (SN--ETC(U)
OCT 79 T S GARNETT, R F CAMPBELL, D J HODDER DAAJ02-77-C-0069
D210-11555-1 NL

UNCLASSIFIED

4 of 5

88 900

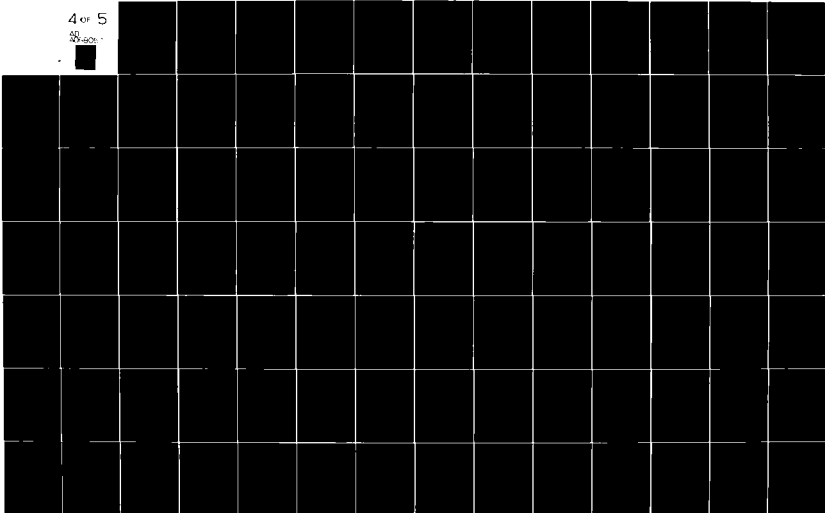

DIE ZEILEN-GOEF-VERBODEN
NOMM 10 10 5 4

DIE ZEILEN-MIT-DIETZEN-GRAPH-PAPER
MILLIMETER

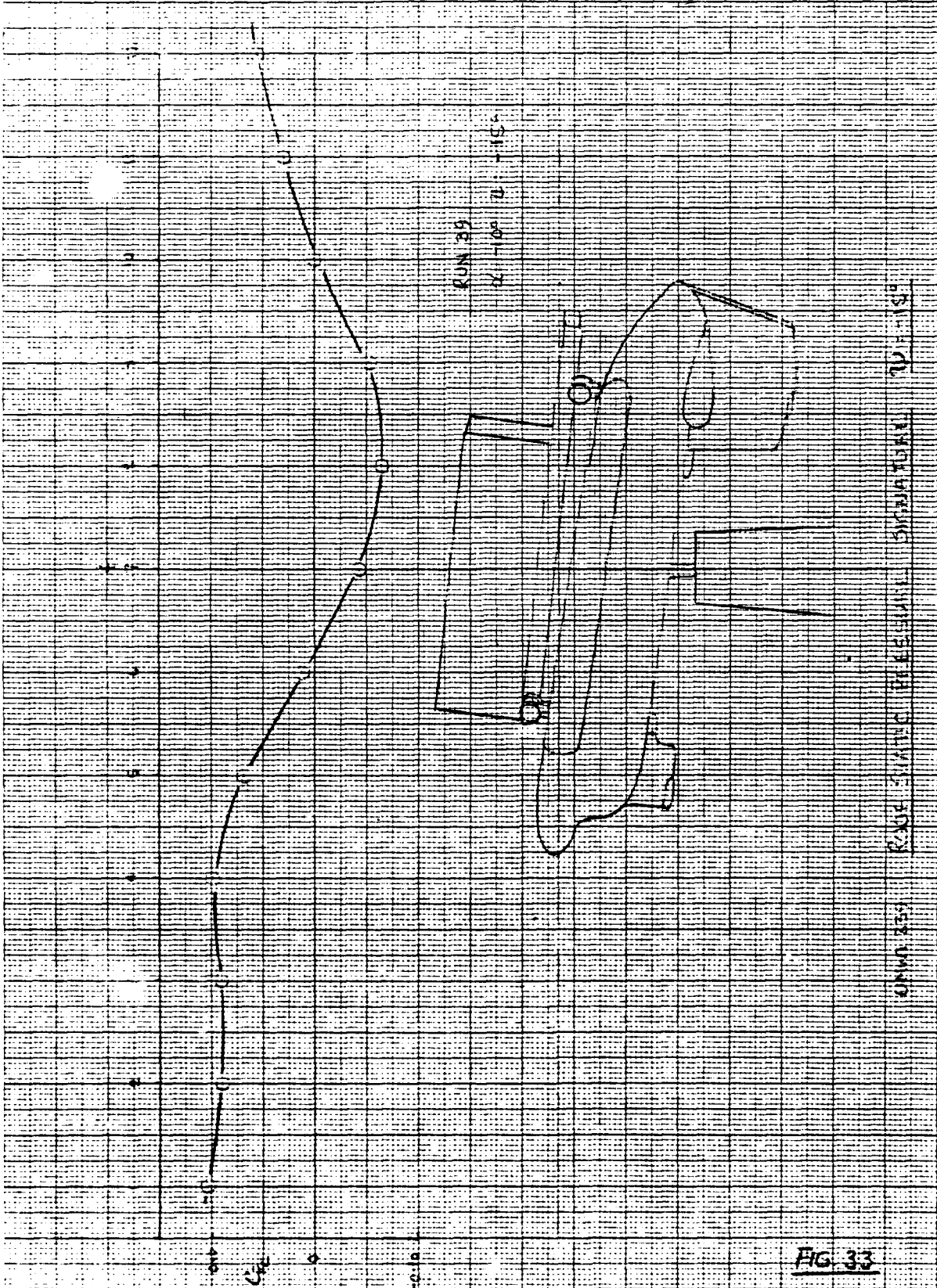
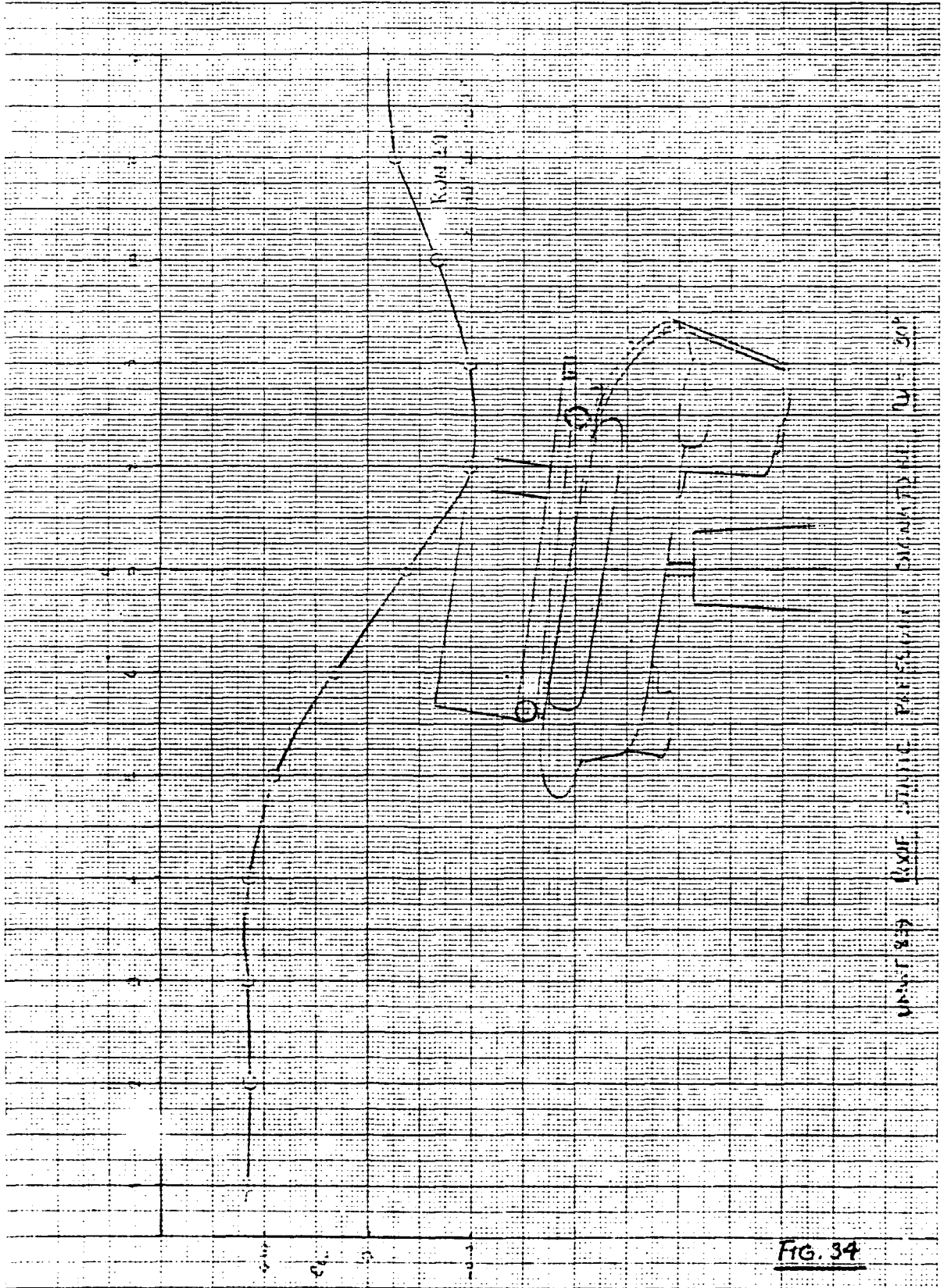

FIG. 33

THE BOEING COMPANY
BOEING BUILDING
SEATTLE, WASHINGTON

THE BOEING COMPANY
BOEING BUILDING
SEATTLE, WASHINGTON



UNIT 829 KUM 20 BRACKET SUPPORT BRACKET PART 301

FIG. 34

5.2 Blockage Corrections

General

The UMWT has, for some time, instead of using standard methods of blockage correction to dynamic pressure calculated during the data reduction process, made use of a ring of static orifices around the working section, at the station of the support strut. Average pressure from these orifices has been used, with normal tunnel total pressure, to obtain a dynamic pressure which approximates very closely a calculated value corrected for solid and wake blockage. The greatest benefit of this system is that the corrected values, which are acquired directly, are accurate for both streamline flow and bluff body flows with high solid and wake blockage (viz., BAH CH-47 Download Test, UMWT 808).

An investigation of the accuracy of dynamic pressure corrections to be applied for the snubload model was considered necessary, due to the complex nature of the model environmental flow field including particularly the component wakes.

The decision was made to utilize the short support strut, since the conventional support with model in tunnel center would have brought the Milvan (on extended struts) into close proximity to the tunnel roof, possibly even to the extent of introducing a solid boundary into the upper portion of the forward bubble separation.

Fig. 35, following, shows the flow and wake structure that can be expected to exist around the Snubload Model, necessitating the following initial considerations:

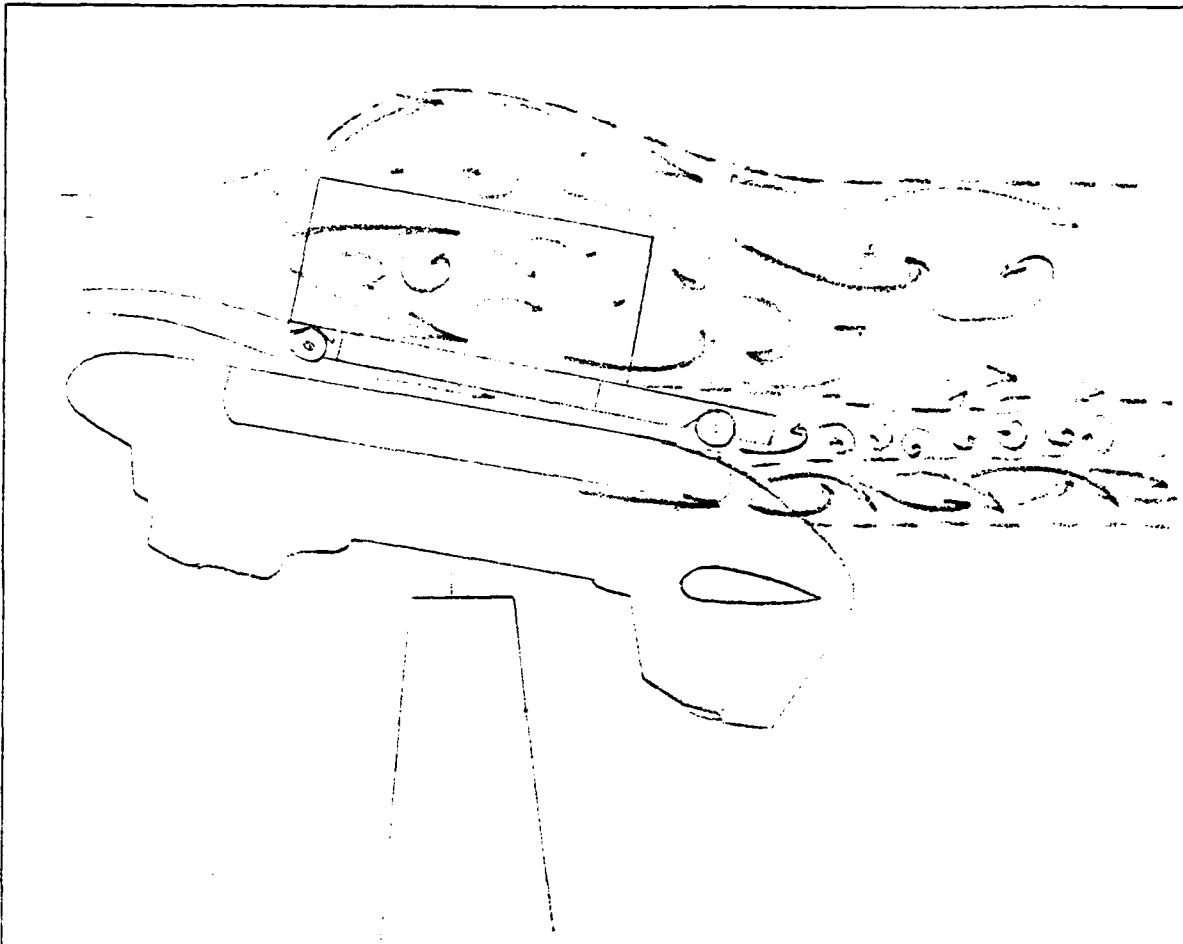

1. Flow above the Milvan, consisting of forward bubble separations, generates a bluff body wake with some vortex interaction at the freestream boundaries. Strouhal effects indicate that vortex shedding from corner flow at the test dynamic pressure would occur at approx. 79 HZ giving an amplitude of approx. 0.16 in over a wavelength of 32 ins.
2. Flow over the model fuselage remains essentially streamline, with incidence dependent bluff body wake from the ramp. The ramp wake is characterized by the twin vortex helices extending from the side curvatures.

3. Between the Adapter/Milvan wake and the fuselage wake there is an area of slipstreamed flow, sensitive to the positioning of each of the flanking components.
4. The complex character of the composite wake, including interactions, does not lend itself to any classical correction method, but rather to semi-empirical relationships such as those developed by Maskell et al. These can be used adequately, since the empirical quantities can be assessed in various ways and thereby cross-checked, using measured parameters in the appropriate relationships.

Contributions to Corrections:

These items are considered in estimating blockage corrections:

1. Solid Blockage (correction to velocity)
2. Wake Blockage (correction to velocity)
3. Wake Distortion (correction to velocity)
4. Buoyancy (correction to drag)

Measured Parameters:

In order to provide an adequate data base for determining corrections and thereby checking the validity of the working section centerline static pressure reference, measurements were made as follows:

1. Pressure signature, from roof statics.
2. Base pressures of Milvan and model fuselage, from pressure taps in the component surfaces.
3. Wake areas, from tuft wands attached in various locations (Figs. 36, 37).
4. Other pertinent tunnel and model parameter measurement.

Corrections to Velocity

Nomenclature:

B	Wake cross-sectional area
C	test section area
C_D	uncorrected profile drag coefficient
C_p	wall pressure coefficient
C_{pB}	base pressure coefficient
ϵ	blockage correction factor
ϵ_{SB}	solid blockage
ϵ_{WB}	wake blockage
q_u	uncorrected dynamic pressure
q_c	corrected dynamic pressure
L	model length
S	model reference area

Correction calculated in the form:

$$q_c = q_u (1 + \epsilon_B) \quad \text{and} \quad \epsilon_B = \epsilon_{SB} + \epsilon_{WB}$$

- The Solid Blockage contribution is:

$$\epsilon_{SB} = \frac{0.87 (\text{Model Volume})}{2C^{1.5}}$$

- Wake Blockage from methods outlined in IOM 8-7891-1-438:

$$1. \text{ Bluff body blockage factor} = \frac{1}{K_C^2 - 1}$$

where $K_C^2 - 1 = -C_{pBC}$, the corrected base pressure coefficient

This quantity is found from an iterative solution of:

$$\frac{K^2}{K_C^2} = 1 + \frac{C_D}{(K_C^2 - 1)} \cdot \frac{S}{c}$$

where K^2 is measurable from

$$K^2 - 1 = -C_{pB}$$

2. Also: $(K^2 - 1)$ from

$$C_D = m (K^2 - 1 - m \frac{S}{C}) \text{ where } m = \frac{B}{S}$$

(C_D in wind axes)

• Buoyancy

$$\Delta C_D = - \frac{\Delta C_p}{L} \frac{(\text{Model Volume})}{S}$$

Taking, as a check case for the centerline static correction method for blockage, Run 14:

$$\alpha = -10^\circ \quad \psi = 0^\circ$$

$$C_{Ds} = 0.725$$

$$\epsilon_{SB} = 0.0042$$

$$C_{pB} = -0.454$$

Then the corrected base static pressure is:

$$C_{pBC} = -(K^2 - 1) = -0.402$$

and $\epsilon = 2.487$.

Therefore:

$$\epsilon_{WB} = 0.0537$$

Total Blockage correction:

$$\epsilon_{SB} + \epsilon_{WB} = 0.0042 + 0.0537 = 0.0579$$

i.e.
$$q_C = q_{IND} \times 1.0579$$

The wake area was 4.58 sq. ft as measured, which gives a check of the base pressure from:

$$C_D = m (K^2 - 1 - m S/C)$$

$$K^2 - 1 = (-C_{pB}) = 0.470$$

The corresponding centerline static correction was:

$$q_C = q_{IND} \times 1.054$$

which is within 0.5% of the calculated value.

The buoyancy correction gives a fairly constant drag adjustment of -2.7 sq ft to final data.

5.3 Final Data Format

Final data was presented in the format shown below, for force and moment data, referenced to full scale CG location.

UNIVERSITY OF MARYLAND
WIND TUNNEL OPERATIONS DEPT.
TEST NO 839

BOEING VERTOL CH47 BOXES

W.T. TEST RUN 37

FULL SCALE DATA/Q

Q PSF	AA DEG	AY DEG	L/Q	D/Q	BODY AXES		RY/Q	SF/Q
					M/Q	YH/Q		
50.00	-20.0	.0	-113.3	119.34	-1571.7	73.7	-32.1	-6.0
50.00	-15.0	.0	-86.8	117.07	-1323.8	16.1	-19.1	-3.8
50.00	-12.0	-.1	-73.2	115.76	-1187.3	14.5	-9.6	-3.9
50.00	-10.0	.0	-64.1	114.18	-1085.9	26.7	-11.5	-4.0
50.00	-8.0	.0	-52.9	111.83	-989.9	36.0	-11.2	-3.6
50.00	-6.0	.0	-43.9	109.54	-893.5	44.3	-12.2	-3.7
50.00	-4.0	.0	-33.8	106.85	-789.2	56.7	-13.2	-3.6
50.00	-2.0	.0	-25.3	104.63	-659.3	56.0	-9.6	-3.6
50.00	.0	.0	-15.1	103.00	-536.3	55.7	-8.4	-3.8
50.00	2.0	.0	-4.3	101.65	-413.4	56.1	-1.8	-4.5
50.00	4.0	.0	9.0	101.17	-340.7	37.0	7.4	-3.8
50.00	6.0	.0	24.1	102.84	-283.0	22.4	15.1	-3.5
50.00	8.0	.0	38.2	103.42	-205.0	7.4	24.8	-4.6
50.00	10.0	.0	50.1	102.68	-86.2	7.6	22.7	-4.7
50.00	12.0	.0	62.8	101.11	23.1	4.8	27.0	-4.6
50.00	15.0	.0	87.6	100.32	193.4	-22.6	48.8	-7.8
50.00	20.0	.0	120.4	99.98	568.2	14.7	48.5	-9.0

WIND AXES

---(L/Q)--- (D/Q)

-65.7	150.90
-53.5	135.54
-47.5	128.45
-43.3	123.57
-36.9	118.11
-32.3	113.54
-26.2	108.94
-21.6	105.45
-15.1	103.00
-7.8	101.44
1.9	101.56
13.2	104.79
23.4	107.72
31.5	109.81
40.4	111.96
58.6	119.56
79.0	135.14

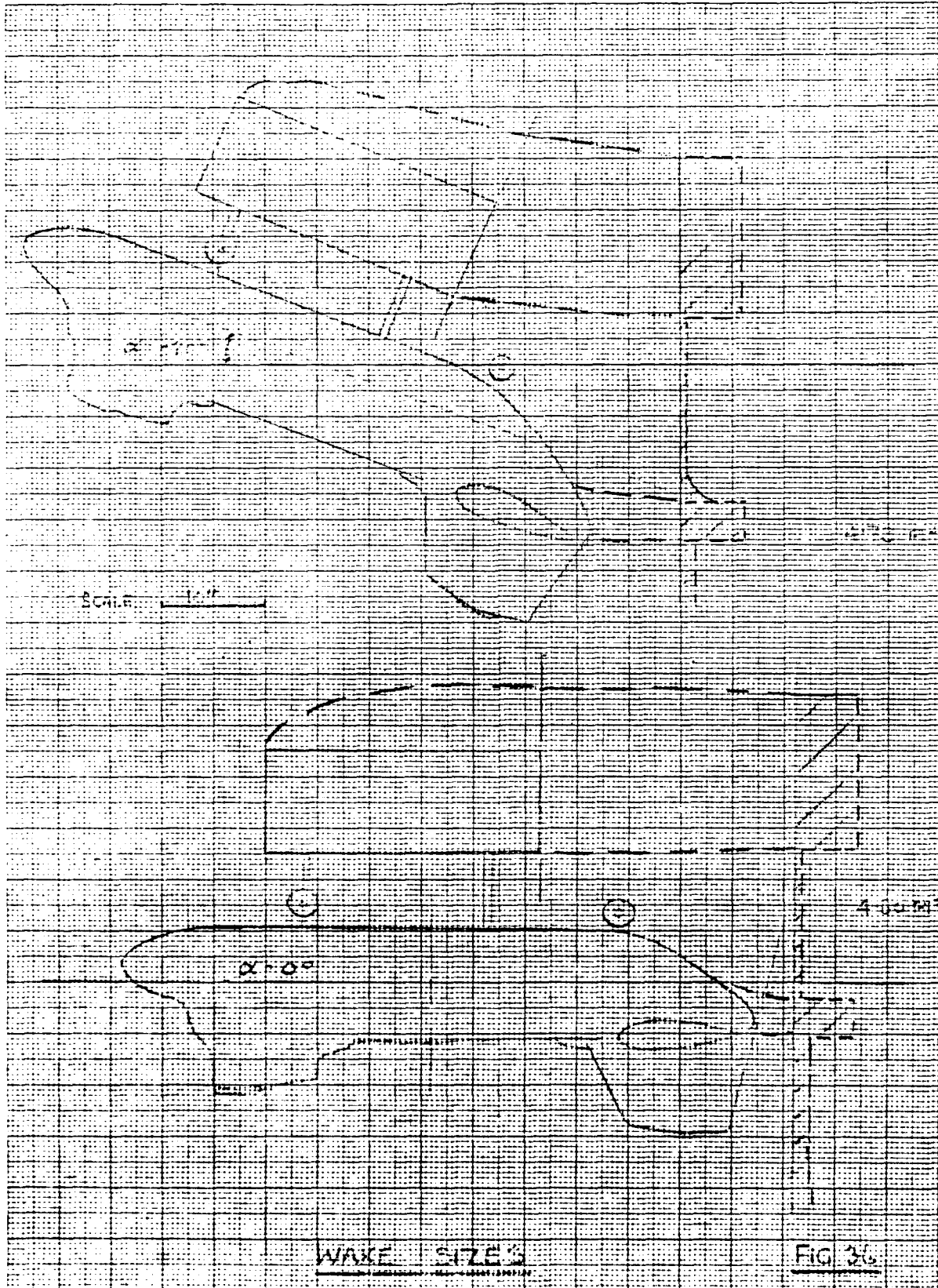

EUGENE DIETZGEN CO.
MADE IN U. S. A.

NO. 340R-MP DIETZGEN GRAPH PAPER
MILLIMETER

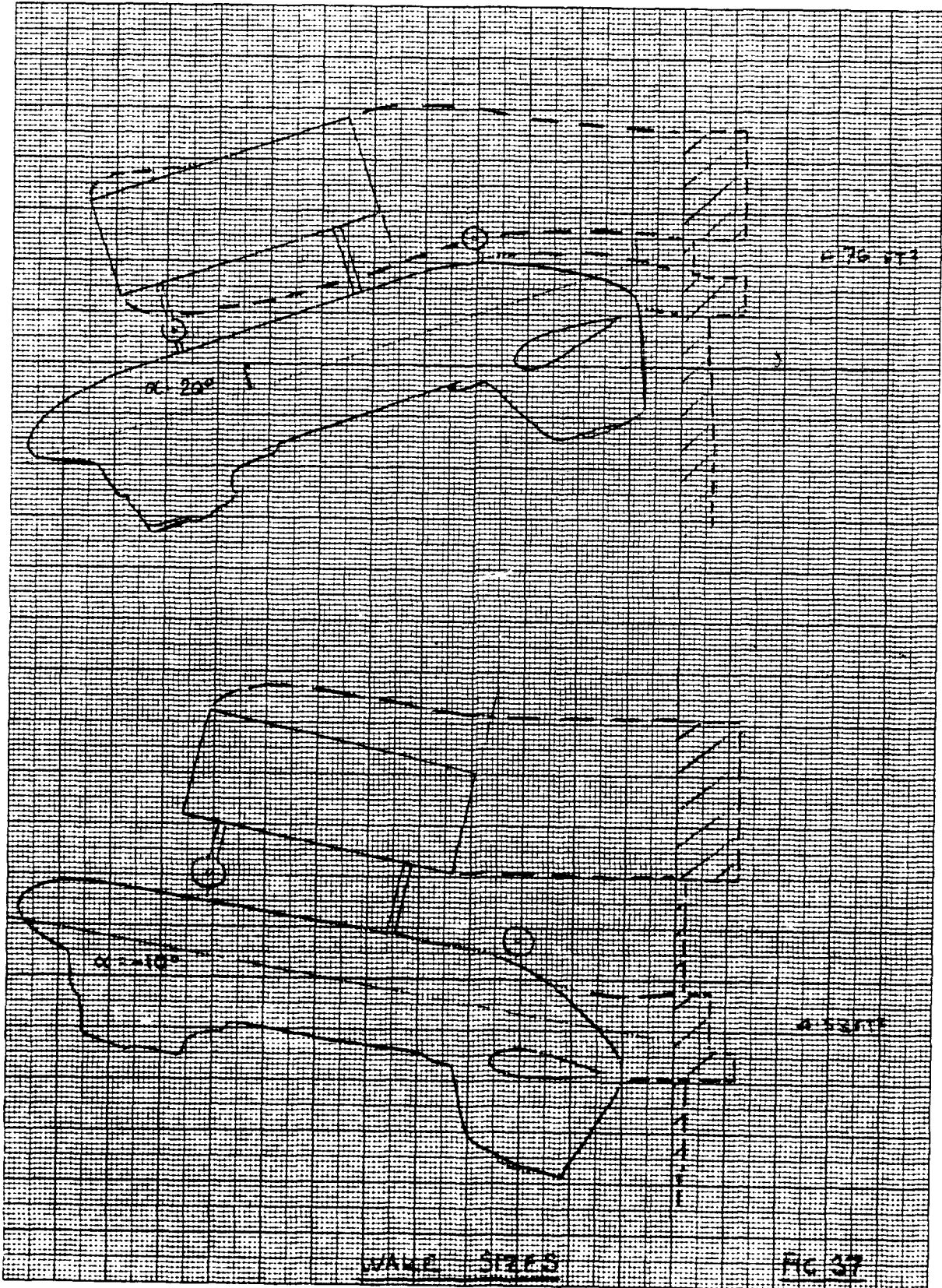

6. RUN LOG: FLAG NOTES

1

$$\alpha = -20, -15, -12 \times 2^{\circ} \quad +12, +15, +20$$

2

$$\psi = 0, 2, 4, 6, 10, 15, 20, 30, 60, 90$$

$$0, -2, -4, -6, -10, -15, -20, -30, -60, -90$$

3

$$g = 30, 50, 75, 100 \text{ PSF}$$

4

$$\psi = 0, 2, 4, 6, 10, 15, 20, 30, 20, 10, 5, 0$$

$$-2, -4, -6, -10, -15, -20, -30,$$

Reduce g to 30 PSF, -60, -90

$$-60, g \text{ to } 50 \text{ PSF}, -30, -20, -10, -5, 0$$

5

$$\psi = 0, 2, 4, 6, 10, 15, 20, 30$$

$$0, -2, -4, -6, -10, -15, -20, -30 \text{ (} g = 30 \text{ PSF)}$$

$$-60, -90$$

6

$$\alpha = -10, -4, 0, 4, 8, 10^{\circ}$$

7

$$\psi = -15, -10, -6, 0, 6, 10, 15, 20, 30^{\circ}$$

8

$$\psi = 0, 2, 4, 6, 8, 10, 15, 20, 30$$

$$0, -2, -4, -6, -8, -10, -15, -20, -30$$

PREP.	CHK.	APPR.	REVISD	DATE	CONFIGURATION	TYPE OF RUN	WT. TARE RUN	q	α°	ψ°	FOOT PRESS	MODEL PRESS	DATE / TIME
					CLEAN SECTION ~ PRESSURES	P	-	3	-	-	YES	-	1045-1200
					K1+TS1	Re	1	✓	-10	-30	✓	YES	1530-1610
					✓	PG	✓	75	1	0	NO*	NO*	1625-1640
					✓	Y6	✓	✓	-10	2*	✓	✓	1645-1740
					✓	✓	✓	50	✓	✓	✓	✓	1710-1820
					K1 + TS1 + S1 ¹⁵ M1	PG	1	✓	1	0	YES	YES	2-12 1050-1130
					✓	Y6	2	✓	-10	4	✓	✓	1130-1320
					✓	PG	1	✓	1	0	✓	✓	1515-1555
					✓	Y6	2	✓	-10	5	✓	✓	1555-1640
					✓	PG	1	✓	1	0	✓	✓	1650-1715
					✓	✓	✓	✓	✓	✓	✓	✓	✓
					1 PRESSURE DATA FROM ROW OF CENTERLINE STATICS IN TUNNEL								ROOF
					2 SWEET								
					K1 BASIC CH47 FUSELAGE. WITH TWD PYLON, FUEL PODS, LANDING GEAR, MACCELLES, AFT PYLON STRIKES (FWD OF CLAR ONLY). PRESSURE PORT #6 ON RAMP								
					1 α° : -20, -15, -12, -10, -8, -6, -4, -2, 0, 2, 4, 6, 8, 10, 12, 15, 20°								
					* PRESSURE DATA @ 0° A +20°								
					2 ψ : 0, +2, +16, +10, +15, +20, +30, +60, +90°								
					* PRESSURE DATA @ 0, +30, +90°								
					3 GETS PRT EXCEEDED BALANCE LIMIT +20, -20 SIDE ZONE @ q = 50 PM (RUNS)								
					4 MYSTERY IS YAW RUN WITH PRESSURE DATA SOME P 5 Y DEFECTS NOTICED DUE TO TWISTING OF BOX RELATIVE TO MODEL								

PREP.	CHK.	APPR.	REVISED	DATE	CONFIGURATION	TYPE OF TARE RUN	WT. TARE RUN	9	α°	ψ°	RUNG PRESS	MOD. PRESS	DATE / TIME
					K1 + TS1 M1 A1.4	P6	1	50	6	0	NO	NO	2-14-79 1500 - 1505
					✓ A1.5	✓	✓	✓	✓	✓	✓	✓	1512 - 1522
					✓ A2.1	✓	✓	✓	✓	✓	✓	✓	1550 - 1600
					✓ A2.2	✓	✓	✓	✓	✓	✓	✓	1620 -
					✓	Y6	2	✓	-10	7	✓	✓	-1705
					✓ A3.1	P6	1	✓	1	0	✓	✓	1745 -
					✓	Y6	2	✓	-10	7	✓	✓	- 1815
					✓ A3.2	P6	1	✓	11	0	✓	✓	0800 - 0830 2:15
					✓ A3.3	✓	✓	✓	✓	✓	✓	✓	1040 - 1100
					✓ A3.4	✓	✓	✓	✓	✓	✓	✓	1112 - 1126

RUN 28	ADAPTER SET @ +175° RELATIVE TO BODY (GAP @ REAR FLUID OF GEAR INCREASED FROM 1175 TO 4"5) A3.2
RUN 29	ADAPTER @ 0° (PARALLEL TO FUSE) 3"50 GAP FWD & AFT (1"37" CLEARANCE FROM WHEELS TO WELLS) A3.3
RUN 30	ADAPTER @ -0.5° TO FUSE (0"75 CLEAR @ AFT WHEELS) UPPER SURFACE TO REAR GEAR @ 1"25. A3.4

CH-47 SNUBLOAD

UMWT

839

7. PHOTO LOG UMWT 839

RUN NO.	Configuration	Frames
6	$K_1 TS_1 S_{15}^{15} M_1$	4
8	$K_1 TS_1^{10} M_1$	2
10	$K_1 TS_1 M_1$	2
14	$K_1 TS_1 A_1 M_1$	2
29	$K_1 TS_1 A_{3.3} M_1$	4
37	$K_1 TS_1 A_{3.7} M_1$	8
42	$K_1 TS_1 A_{3.7} G_1$	2
53	$K_1 TS_1 S_2^{10} G_1$	3
55	$K_1 TS_1 S_2^{10} G_2$	1
60	$K_1 TS_1 A_{4.0} M_1$	7

8. TEST DATA UMWT 839

The following pages present the force and moment data obtained during the UMWT 839 test. Data format is described in Section 5.3.

UNIVERSITY OF MARYLAND
WIND TUNNEL OPERATIONS DEPT.
TEST NO 839

BOEING VEIVTOL CH47 BOXES

FULL SCALE DATA/Q

W.T. TEST RUN 2

Q PSF	AA DEC		AY DEC		L/Q	D/Q	BODY AXES M/Q		RN/Q	SF/Q	WIND AXES (L/Q) (D/Q)	
							M/Q	YM/Q			(L/Q)	(D/Q)
30.00	-10.0	-30.0	-30.0	-30.0	-101.2	4.90	-847.4	-487.9	-244.4	-263.2	-98.8	150.98
50.00	-10.0	-30.0	-30.0	-30.0	-97.5	5.41	-861.4	-377.4	-231.6	-261.6	-95.1	150.07
75.00	-10.0	-30.0	-30.0	-30.0	-94.0	5.67	-883.2	-356.1	-237.3	-259.8	-91.6	148.84
100.00	-10.0	-30.0	-30.0	-30.0	-93.8	5.86	-874.0	-332.8	-243.1	-260.9	-91.3	149.54

UNIVERSITY OF MARYLAND
WIND TUNNEL OPERATIONS DEPT.
TEST NO 839

BOEING VERTOL CH47 BOXES

FULL SCALE DATA/Q

W.T. TEST RUN 3

Q PSF	AA		AY		L/Q	D/Q	BODY AXES		RM/Q	SF/Q	WIND AXES	
	DEC	DEC	DEC	DEC			M/Q	YM/Q			(L/Q)	(D/Q)
75.00	-20.0	.0	.0	.0	-147.3	22.39	-1365.1	75.0	-24.2	.5	-130.7	71.41
75.00	-15.0	.0	.0	.0	-101.4	25.33	-1082.5	68.8	-23.0	.4	-91.4	50.71
75.00	-12.0	.0	.0	.0	-80.3	26.81	-921.8	76.7	-17.1	2.2	-73.0	42.91
75.00	-10.0	.0	.0	.0	-67.2	27.53	-812.2	75.7	-16.0	1.6	-61.4	38.77
75.00	-8.0	.0	.0	.0	-55.1	28.28	-695.1	92.2	-16.7	2.3	-50.6	35.67
75.00	-6.0	.0	.0	.0	-44.5	28.98	-564.4	101.0	-14.9	2.7	-41.2	33.48
75.00	-4.0	.0	.0	.0	-34.8	29.57	-403.3	113.0	-12.8	2.9	-32.7	31.92
75.00	-2.0	.0	.0	.0	-25.5	29.72	-255.3	115.3	-14.0	3.9	-24.4	30.59
75.00	.0	.0	.0	.0	-16.1	29.34	-128.1	110.7	-11.5	4.6	-16.1	29.34
75.00	2.0	.0	.0	.0	-7.8	29.03	34.2	107.3	-15.2	4.3	-8.8	28.74
75.00	4.0	.0	.0	.0	-6	29.16	219.8	121.6	-20.8	4.3	-2.6	29.05
75.00	6.0	.0	.0	.0	7.1	29.05	396.7	130.1	-23.4	4.5	4.0	29.63
75.00	8.0	.0	.0	.0	16.6	28.64	556.0	115.3	-25.1	4.9	12.5	30.67
75.00	10.0	.0	.0	.0	27.8	28.83	675.3	105.6	-23.2	7.3	22.4	33.21
75.00	12.0	.0	.0	.0	38.2	28.55	830.6	90.4	-24.7	9.3	31.4	35.87
75.00	15.0	.0	.0	.0	51.0	26.59	1081.6	81.2	-25.5	5.7	42.4	38.89
75.00	20.0	.0	.0	.0	77.1	23.84	1449.9	96.5	-31.2	7.9	64.3	48.76

UNIVERSITY OF MARYLAND
WIND TUNNEL OPERATIONS DEPT.
TEST NO 839

BOEING VERTOL CH47 BOXES

FULL SCALE DATA/Q

W.T. TEST RUN 4

Q PSF	AA		AY		L/Q	D/Q	BODY AXES		RM/Q	SF/Q	WIND AXES	
	DEC	DEC	DEC	DEC			M/Q	YM/Q			(L/Q)	(D/Q)
75.00	-10.0	.0	.0	.0	-67.9	27.58	-826.9	98.5	-19.3	2.3	-62.1	38.95
75.00	-10.0	-2.0	-2.0	-2.0	-67.2	27.54	-834.2	21.5	-34.8	-11.9	-61.4	39.19
75.00	-10.0	-4.0	-4.0	-4.0	-67.2	27.54	-839.0	-63.6	-47.1	-26.0	-61.4	40.52
75.00	-10.0	-6.0	-6.0	-6.0	-65.8	26.71	-876.4	-89.7	-67.8	-43.9	-60.2	42.10
75.00	-10.0	-10.0	-10.0	-10.0	-65.4	24.76	-939.1	-178.3	-117.2	-81.2	-60.1	49.28
75.00	-10.0	-15.0	-15.0	-15.0	-67.1	21.60	-970.5	-278.4	-159.1	-124.1	-62.4	63.93
75.00	-10.0	-20.0	-20.0	-20.0	-70.8	17.37	-997.1	-304.5	-211.8	-170.2	-66.7	85.83
75.00	-10.0	-30.0	-30.0	-30.0	-98.6	16.95	-1020.6	-256.8	-380.1	-239.9	-94.1	149.23

UNIVERSITY OF MARYLAND
WIND TUNNEL OPERATIONS DEPT.
TEST NO 839

BOEING VERTOL CH47 BOXES

FULL SCALE DATA/Q

W.T. TEST RUN 5

Q PSF	AA DEG	AY DEG	L/Q	D/Q	BODY AXES		RM/Q	SF/Q	WIND AXES	
					M/Q	YH/Q			(L/Q)	(D/Q)
50.00	-10.0	0	-66.9	27.82	-811.3	75.4	-14.5	.3	-61.1	39.01
50.00	-10.0	-2.0	-67.1	28.00	-823.1	1.2	-31.1	-14.2	-61.2	39.69
50.00	-10.0	-4.0	-66.7	27.67	-840.4	-73.4	-44.5	-29.8	-60.9	40.82
50.00	-10.0	-6.0	-65.6	26.87	-861.6	-110.4	-58.4	-47.4	-59.9	42.59
50.00	-10.0	-10.0	-65.9	25.01	-908.7	-194.5	-110.1	-82.4	-60.5	49.83
50.00	-10.0	-15.0	-70.0	21.66	-920.3	-309.4	-149.2	-124.4	-65.2	64.54
50.00	-10.0	-20.0	-71.0	17.07	-921.6	-348.5	-184.5	-170.7	-66.9	85.75
50.00	-10.0	-30.0	-98.1	4.90	-856.1	-384.5	-222.8	-259.7	-95.7	148.79
50.00	-10.0	-60.0	-308.0	-19.91	-1567.0	-623.1	210.6	-475.9	-306.8	429.06
50.00	-10.0	-90.0	-346.6	-31.29	-323.7	940.2	232.7	-446.8	-346.8	446.82
50.00	-10.0	0	-67.3	28.01	-825.9	105.1	5.9	3.2	-61.4	39.27
50.00	-10.0	2.0	-67.3	28.00	-840.6	160.6	13.0	19.4	-61.4	39.92
50.00	-10.0	3.9	-66.9	27.67	-855.1	174.8	37.5	35.5	-61.1	41.19
50.00	-10.0	6.0	-68.1	27.23	-851.2	186.7	77.3	55.5	-62.3	44.24
50.00	-10.0	10.0	-70.6	25.68	-848.6	283.0	107.3	90.8	-65.0	52.75
50.00	-10.0	15.0	-76.2	22.91	-825.5	408.7	110.1	132.2	-71.0	68.77
50.00	-10.0	20.0	-77.1	20.06	-694.3	503.8	-143.1	174.0	-72.4	90.66
50.00	-10.0	30.0	-105.3	11.66	-418.1	574.6	-463.5	252.0	-101.6	151.78
50.00	-10.0	90.0	-362.6	-23.59	-393.3	-1064.1	-99.6	443.5	-361.2	443.51
50.00	-10.0	60.1	-311.5	-14.06	-1063.8	790.2	-294.7	483.1	-309.2	438.02

UNIVERSITY OF MARYLAND
WIND TUNNEL OPERATIONS DEPT.
TEST NO 839

BOEING VERTOL CH47 BOXES

FULL SCALE DATA/Q

W.T. TEST RUN 6

Q PSF	AA DEC	AY DEC	L/Q	D/Q	BODY AXES		RM/Q	SF/Q	WIND AXES	
					M/Q	YM/Q			(L/Q)	(D/Q)
50.00	-20.0	.0	-169.5	107.44	-2491.8	140.1	-188.9	4.9	-122.5	158.91
50.00	-15.0	.0	-123.7	108.42	-2185.7	137.6	-159.2	3.8	-91.4	136.73
50.00	-12.0	.0	-100.4	107.12	-1975.1	111.3	-139.2	5.9	-75.9	125.64
50.00	-10.0	.0	-87.0	106.46	-1828.4	100.7	-122.1	6.1	-67.2	119.95
50.00	-8.0	.0	-74.6	106.15	-1675.8	112.0	-122.3	6.3	-59.1	115.51
50.00	-6.0	.0	-61.3	104.88	-1508.2	110.7	-110.6	6.1	-50.0	110.72
50.00	-4.0	.0	-48.5	103.18	-1377.3	88.9	-111.2	8.1	-41.2	106.32
50.00	-2.0	.0	-35.4	101.06	-1232.1	75.9	-106.0	8.2	-31.9	102.23
50.00	.0	.0	-18.0	99.34	-1109.1	74.7	-112.9	8.6	-18.8	99.34
50.00	2.0	.0	-2.6	101.76	-1069.1	77.1	-97.8	7.6	-6.1	101.61
50.00	4.0	.0	12.8	105.27	-1022.6	78.7	-100.0	8.6	5.4	105.91
50.00	6.0	.0	26.2	107.31	-936.6	94.7	-106.1	8.7	14.8	109.47
50.00	8.0	.0	38.4	108.02	-789.1	106.5	-110.4	9.1	23.0	112.32
50.00	10.0	.0	51.3	107.89	-633.4	96.5	-114.3	9.7	31.7	115.15
50.00	12.0	.0	65.8	107.86	-489.8	88.9	-121.7	11.8	42.0	119.19
50.00	15.0	.0	80.4	107.80	-296.9	95.7	-131.1	5.9	57.5	127.00
50.00	20.0	.0	132.3	104.51	21.2	87.0	-147.5	9.3	88.6	143.45

UNIVERSITY OF MARYLAND
WIND TUNNEL OPERATIONS DEPT.
TEST NO 839

BOEING VERTOL CH47 BOXES

FULL SCALE DATA/Q

V.T. TEST RUN 7

Q PSF	AA DEC	AY DEC	L/Q	D/Q	M/Q	Y/M/Q	RM/Q	SF/Q	(L/Q)	WIND AXES (D/Q)
50.00	-10.0	0	-87.1	106.18	-1743.1	88.9	-124.1	7.4	-67.3	119.69
50.00	-10.0	-2.0	-87.1	106.13	-1759.1	-4.2	74.2	-21.3	-67.3	120.31
50.00	-10.0	-4.0	-86.9	106.53	-1782.1	-91.1	261.6	-49.8	-67.1	123.19
50.00	-10.0	-6.0	-86.6	107.17	-1839.2	-128.1	418.2	-79.9	-66.7	128.27
50.00	-10.0	-10.0	-89.9	108.33	-1984.3	-237.7	669.3	-135.7	-69.8	144.00
50.00	-10.0	-15.0	-101.3	105.87	-2125.4	-424.0	961.2	-201.5	-81.4	169.84
50.00	-10.0	-20.0	-104.0	103.97	-2138.3	-542.3	1285.4	-273.9	-84.4	206.86
50.00	-10.0	-30.0	-114.7	102.57	-2135.4	-645.6	1729.3	-386.4	-95.1	297.91
50.00	-10.0	-30.0	-111.3	87.12	-2023.6	-792.0	1902.6	-413.3	-94.5	297.69
50.00	-10.0	-30.0	-111.6	86.93	-2021.6	-787.7	1894.1	-411.9	-94.8	296.88
50.00	-10.0	-19.9	-70.2	-86.08	161.4	-274.8	1394.4	-200.5	-84.1	.00
50.00	-10.0	-15.0	-101.3	105.77	-2118.0	-431.5	970.9	-198.9	-81.4	169.09
50.00	-10.0	-10.0	-89.5	108.11	-1978.5	-245.2	681.0	-133.3	-69.4	143.30
50.00	-10.0	-6.0	-86.6	107.26	-1834.0	-132.9	427.2	-77.7	-66.7	128.13
50.00	-10.0	0	-87.5	106.85	-1757.5	98.5	-132.0	9.3	-67.6	120.41
50.00	-10.0	2.0	-87.9	108.31	-1790.1	157.3	-317.2	37.7	-67.7	123.16
50.00	-10.0	3.9	-88.8	109.76	-1836.0	190.4	-445.7	65.8	-68.4	127.69
50.00	-10.0	6.0	-90.1	111.63	-1889.6	216.8	-557.7	96.9	-69.4	135.01
50.00	-10.0	10.0	-99.7	112.69	-1974.1	370.9	-784.1	148.0	-78.6	152.04
50.00	-10.0	15.0	-108.9	110.26	-2078.6	590.3	-1091.7	214.1	-88.1	178.56
50.00	-10.0	20.0	-107.4	107.97	-2041.9	737.7	-1485.0	285.6	-87.0	215.13
50.00	-10.0	20.0	-106.4	107.15	-2047.0	760.1	-1450.3	285.0	-86.1	213.98
50.00	-10.0	30.0	-104.8	92.39	-1672.2	1095.1	-2481.4	418.0	-87.2	303.56
30.00	-10.0	60.1	-233.9	14.64	-1210.7	1929.6	-3933.8	716.6	-227.8	648.62
30.00	-10.0	90.0	-179.6	-17.28	-588.7	-708.4	-3648.3	695.8	-179.8	695.79

UNIVERSITY OF MARYLAND
WIND TUNNEL OPERATIONS DEPT.
TEST NO 039

BOEING VERTOL CH47 BOXES

FULL SCALE DATA/Q

W.T. TEST RUN 8

Q PSF	AA DEC	AY DEC	L/Q	D/Q	BODY AXES		RM/Q	SF/Q	WIND AXES	
					M/Q	YM/Q			(L/Q)	(D/Q)
50.00	-20.0	.0	-153.8	108.34	-2008.3	62.7	-92.5	6.4	-107.5	154.42
50.00	-20.0	.0	-154.2	108.19	-2006.7	62.9	-90.5	5.4	-107.9	154.41
50.00	-15.0	.0	-114.8	107.82	-1729.7	51.1	-63.1	4.7	-82.9	133.85
50.00	-12.0	.0	-93.9	107.03	-1565.9	44.9	-51.9	4.5	-69.6	124.22
50.00	-10.0	.0	-80.7	106.21	-1452.2	55.7	-55.7	5.6	-61.1	118.62
50.00	-8.0	.0	-68.2	105.59	-1331.1	61.3	-56.6	5.8	-52.9	114.06
50.00	-6.0	.0	-57.1	104.92	-1217.4	68.1	-55.8	5.0	-45.8	110.31
50.00	-4.0	.0	-45.7	103.42	-1074.9	86.1	-65.9	4.5	-38.4	106.36
50.00	-2.0	.0	-33.9	101.38	-942.8	99.0	-67.7	4.5	-30.3	102.50
50.00	.0	.0	-20.4	99.47	-830.6	98.0	-74.8	4.4	-20.4	99.47
50.00	2.0	.0	-4.1	100.38	-760.9	104.4	-64.2	4.0	-7.6	100.17
50.00	4.0	.0	10.4	103.57	-717.2	94.2	-55.7	4.9	3.2	104.05
50.00	6.0	.0	24.3	105.87	-631.2	89.4	-50.4	5.5	13.1	107.83
50.00	8.0	.0	37.2	106.25	-524.1	79.2	-49.6	5.9	22.0	110.39
50.00	10.0	.0	50.1	105.59	-393.2	78.0	-53.7	5.9	31.0	112.68
50.00	12.0	.0	65.1	104.74	-263.7	63.7	-58.6	8.2	41.9	115.98
50.00	15.0	.0	88.1	103.41	-88.4	46.8	-43.1	4.2	58.4	122.70
50.00	20.0	.0	130.6	101.80	198.1	77.4	-53.0	5.1	87.9	140.34

UNIVERSITY OF MARYLAND
WIND TUNNEL OPERATIONS DEPT.
TEST NO 839

BOEING VERTOL CH47 BOXES

FULL SCALE DATA/Q

W.T. TEST RUN 9

Q PSF	AA DEC	AY DEC	L/Q	D/Q	BODY AXES			RM/Q	SF/Q	WIND AXES	
					M/Q	YM/Q				(L/Q)	(D/Q)
50.00	-10.0	0	-81.5	106.42	-1412.8	52.4	-52.4	5.2	-61.8	118.96	
50.00	-10.0	2.0	-82.2	107.78	-1433.2	154.6	-220.9	34.9	-62.2	121.56	
50.00	-10.0	3.9	-82.8	109.21	-1464.0	200.1	-330.1	64.8	-62.6	126.05	
50.00	-10.0	6.0	-84.1	111.16	-1505.1	237.9	-420.4	95.9	-63.5	133.41	
50.00	-10.0	10.0	-89.8	112.03	-1537.8	356.0	-568.4	151.3	-69.0	150.27	
50.00	-10.0	15.0	-97.2	109.54	-1694.6	607.3	-822.9	218.0	-76.7	176.92	
50.00	-10.0	20.0	-92.8	108.19	-1622.3	790.8	-1220.8	289.0	-72.6	214.09	
50.00	-10.0	30.0	-81.2	90.50	-1266.5	1066.5	-2237.8	423.6	-64.3	301.20	
50.00	-10.0	0	-81.7	105.57	-1401.9	50.4	-63.0	4.4	-62.1	118.14	
50.00	-10.0	-6.0	-81.4	107.78	-1493.0	-141.9	337.9	-84.7	-61.4	120.47	
50.00	-10.0	-10.0	-85.0	109.34	-1627.9	-263.0	520.0	-141.7	-64.8	145.19	
50.00	-10.0	-15.0	-92.4	106.13	-1741.6	-447.1	752.7	-211.9	-72.6	171.29	
50.00	-10.0	-20.0	-93.8	105.31	-1747.8	-607.5	998.5	-284.2	-74.1	209.97	
50.00	-10.0	-30.0	-86.5	86.85	-1645.7	-864.9	1446.2	-428.6	-70.1	301.36	
30.00	-10.0	-60.0	-216.8	14.70	-1342.7	-1850.1	3311.6	-730.2	-211.0	650.39	
30.00	-10.0	-90.0	-144.8	-41.26	292.1	596.7	3085.3	-720.5	-149.8	720.47	

UNIVERSITY OF MARYLAND
WIND TUNNEL OPERATIONS DEPT.
TEST NO 839

BOEING VERTOL CH47 BOXES

FULL SCALE DATA/Q

W.T. TEST RUN 10

Q PSF	AA DEC	AY DEC	L/Q	D/Q	BODY AXES		RM/Q	SF/Q	WIND AXES	
					M/Q	YM/Q			(L/Q)	(D/Q)
50.00	-20.0	.0	-103.5	106.34	-1372.4	55.7	-32.5	8.6	-60.9	135.33
50.00	-15.0	.0	-78.7	104.93	-1134.1	43.7	-30.8	9.2	-48.9	121.73
50.00	-12.0	.0	-66.2	103.31	-977.0	41.0	-27.2	9.0	-43.5	113.84
50.00	-10.0	.0	-57.0	96.0	-868.1	42.6	-23.9	7.6	-38.8	108.34
50.00	-8.0	.0	-48.4	96.0	-748.4	45.7	-24.0	7.3	-34.4	102.78
50.00	-6.0	.0	-39.9	94.39	-648.0	46.0	-22.5	7.2	-29.8	98.05
50.00	-4.0	.0	-32.7	91.37	-551.9	41.6	-22.4	7.8	-26.2	93.43
50.00	-2.0	.0	-26.8	88.67	-394.5	38.8	-24.1	8.3	-23.7	89.55
50.00	.0	.0	-20.2	85.64	-234.3	42.3	-27.9	7.9	-20.2	85.64
50.00	2.0	.0	-11.3	82.80	-83.9	43.6	-30.5	7.3	-14.2	82.36
50.00	4.0	.0	2.0	81.55	40.4	43.4	-33.6	8.6	-3.7	81.48
50.00	6.0	.0	17.2	83.05	150.3	61.9	-35.2	7.9	8.4	84.39
50.00	8.0	.0	30.8	84.71	241.1	73.1	-30.7	8.1	18.7	88.17
50.00	10.0	.0	43.5	86.96	363.3	75.3	-42.6	7.3	27.8	93.20
50.00	12.0	.0	55.5	89.38	476.2	54.7	-42.2	5.6	35.7	98.97
50.00	15.0	.0	71.3	92.61	721.9	43.5	-37.3	4.9	44.9	107.92
50.00	20.0	.0	98.1	95.92	1054.6	48.2	-42.9	5.6	59.4	123.69
50.00	.0	.0	-20.4	85.52	-226.9	50.3	-27.5	6.9	-20.4	85.52

UNIVERSITY OF MARYLAND
WIND TUNNEL OPERATIONS DEPT.
TEST NO 839

BOEING VERTOL CH47 BOXES

FULL SCALE DATA/Q

V.T. TEST RUN 11

Q PSF	AA DEC	AY DEC	L/Q	D/Q	BODY AXES			RM/Q	SF/Q	WIND AXES	
					M/Q	YN/Q	(L/Q)			(D/Q)	
50.00	-10.0	0	-56.5	99.95	-828.3	43.2	-27.4	-.8	-38.3	108.24	
50.00	-10.0	2.0	-56.8	99.45	-832.5	24.3	-51.4	43.3	-38.7	109.25	
50.00	-10.0	3.9	-58.4	99.50	-838.0	-25.5	-64.3	83.8	-40.2	113.57	
50.00	-10.0	6.0	-60.8	100.29	-821.4	-112.3	-51.3	124.8	-42.5	121.77	
50.00	-10.0	10.0	-53.7	91.75	-933.3	187.0	-267.3	232.2	-37.0	138.48	
50.00	-10.0	15.0	-38.4	95.94	-888.2	205.6	-646.4	287.0	-21.1	171.97	
50.00	-10.0	20.0	-12.4	88.82	-755.6	422.5	-1240.0	367.7	3.2	209.97	
50.00	-10.0	30.0	64.0	60.34	-369.7	496.8	-2540.8	524.8	73.5	304.22	
50.00	-10.0	0	-57.1	100.49	-837.1	43.1	-35.3	-2.6	-38.8	103.88	
50.00	-10.0	-6.0	-58.7	100.85	-856.4	240.0	-11.6	-126.2	-40.3	122.10	
50.00	-10.0	-10.0	-53.5	97.99	-1077.7	60.3	21.0	-201.4	-35.7	139.16	
50.00	-10.0	-15.0	-39.6	92.48	-1212.9	-69.8	63.9	-301.9	-22.9	172.74	
50.00	-10.0	-20.0	-13.4	84.06	-1289.1	-209.5	103.5	-389.6	1.4	213.22	
50.00	-10.0	-30.0	67.4	45.30	-1507.4	-260.4	214.7	-565.3	74.2	311.21	
30.00	-10.0	-60.0	-70.2	-29.30	-415.4	-2051.8	1373.8	-736.5	-74.2	629.46	
30.00	-10.0	-90.0	-29.6	-36.32	348.0	845.2	1262.5	-710.3	-35.4	710.34	
50.00	-10.0	-2.0	-57.5	99.95	-855.9	80.3	-13.2	-39.5	-39.3	109.73	
50.00	-10.0	-4.0	-57.1	99.04	-839.7	130.8	5.2	-79.6	-39.0	112.74	

UNIVERSITY OF MARYLAND
WIND TUNNEL OPERATIONS DEPT.
TEST NO 839

BOEING VERTOL CH47 BOXES

FULL SCALE DATA/Q

W.T. TEST RUN 12

Q PSF	AA DEC	AY DEC	L/Q	D/Q	BODY AXES M/Q	Y/M/Q	RM/Q	SF/Q	(L/Q)	WIND AXES (D/Q)
50.00	-20.0	.0	-124.5	110.91	-1688.1	66.4	-60.3	2.9	-79.1	146.82
50.00	-15.0	.0	-94.5	106.87	-1386.2	45.0	-46.1	2.2	-63.6	127.68
50.00	-12.0	.0	-70.9	104.64	-1229.5	40.3	-34.9	2.0	-53.5	118.35
50.00	-8.0	.0	-54.7	102.15	-1039.3	56.2	-36.4	2.0	-39.9	108.76
50.00	-6.0	.0	-44.8	100.94	-939.8	62.3	-35.7	1.7	-34.0	105.08
50.00	-4.0	.0	-34.4	99.61	-836.5	66.3	-34.7	1.3	-27.4	101.77
50.00	-2.0	.0	-24.9	98.09	-720.6	87.7	-37.3	1.8	-21.5	98.91
50.00	.0	.0	-14.7	96.68	-603.0	77.6	-36.6	1.4	-14.7	96.68
50.00	2.0	.0	-3.5	95.54	-485.1	81.6	-35.4	2.4	-6.8	95.36
50.00	4.0	.0	10.5	97.61	-429.2	68.5	-30.9	2.9	3.7	98.11
50.00	6.0	.0	20.5	100.31	-380.9	59.4	-30.9	3.5	14.8	102.43
50.00	8.0	.0	38.0	101.16	-304.0	56.7	-28.1	3.5	33.6	105.46
50.00	10.0	.0	48.7	100.66	-185.2	57.2	-26.8	3.5	30.5	107.58
50.00	12.0	.0	60.7	99.79	-60.5	53.1	-25.5	3.8	38.7	110.23
50.00	15.0	.0	77.8	98.83	141.2	38.3	-20.8	1.2	49.5	115.58
50.00	20.0	.0	110.9	99.87	463.4	61.4	-23.3	1.4	70.0	131.76

UNIVERSITY OF MARYLAND
WIND TUNNEL OPERATIONS DEPT.
TEST NO 839

BOEING VERTOL CR47 BOXES

FULL SCALE DATA/Q

W.T. TEST RUN 13

Q PSF	AA DEC	AY DEC	L/Q	D/Q	BODY AXES		RM/Q	SF/Q	WIND AXES	
					M/Q	YM/Q			(L/Q)	(D/Q)
50.00	-10.0	0	-66.7	103.51	-1116.5	61.3	-39.6	4.0	-47.7	113.52
50.00	-10.0	3.9	-72.2	106.40	-1087.7	220.1	-223.3	65.3	-52.6	121.48
50.00	-10.0	6.0	-73.5	108.78	-1118.4	261.5	-280.0	96.4	-53.5	129.31
50.00	-10.0	10.0	-76.5	109.07	-1213.7	-84.1	-435.4	154.0	-56.4	145.74
50.00	-10.0	15.0	-75.0	104.79	-1306.2	609.7	-531.7	231.1	-55.7	172.07
50.00	-10.0	20.0	-67.4	102.16	-1166.7	857.0	-902.0	303.1	-48.6	209.19

UNIVERSITY OF MARYLAND
WIND TUNNEL OPERATIONS DEPT.
TEST NO 839

BOEING VERTOL CH47 BOXES

FULL SCALE DATA/Q

W.T. TEST RUN 14

Q PSF	AA DEC	AY DEC	L/Q	D/Q	M/Q	YM/Q	RM/Q	SP/Q	(L/Q)	WIND AXES (D/Q)
50.00	-20.0	.0	-93.0	146.57	-1844.6	65.0	-84.0	6.7	-37.2	169.54
50.00	-15.0	.0	-65.4	146.60	-1551.5	17.4	-62.5	6.8	-25.2	158.53
50.00	-12.0	.0	-53.2	143.57	-1389.1	23.1	-54.3	5.9	-22.1	151.49
50.00	-10.0	.0	-46.2	140.28	-1278.0	31.9	-52.8	6.5	-21.1	146.16
50.00	-8.0	.0	-38.8	136.25	-1153.9	37.5	-39.2	4.9	-19.5	140.33
50.00	-6.0	.0	-31.3	132.55	-1037.4	44.7	-44.0	4.9	-17.3	135.09
50.00	-4.0	.0	-24.2	129.46	-926.8	49.7	-39.2	4.1	-15.1	130.83
50.00	-2.0	.0	-16.4	125.85	-816.4	65.7	-82.2	2.9	-12.0	126.35
50.00	.0	.0	-8.2	122.05	-696.1	73.2	-30.8	3.1	-8.2	122.05
50.00	2.0	.0	.4	118.87	-564.7	70.2	-27.2	3.3	-3.7	118.81
50.00	4.0	.0	10.5	116.94	-473.2	72.6	-24.8	3.1	2.3	117.39
50.00	6.0	.0	22.7	115.15	-367.6	80.3	-23.1	3.3	19.5	116.89
50.00	8.0	.0	34.7	115.25	-297.8	71.5	-20.1	3.5	18.3	118.95
50.00	10.0	.0	47.7	117.16	-246.3	66.1	-32.6	3.8	26.6	123.66
50.00	12.0	.0	60.3	118.84	-157.2	43.6	-23.3	2.7	34.3	128.78
50.00	15.0	.0	76.1	119.51	24.1	16.9	-11.2	1.8	42.6	135.14
50.00	20.0	.0	110.2	120.09	318.5	33.4	-12.8	2.2	62.5	150.53

UNIVERSITY OF MARYLAND
WIND TUNNEL OPERATIONS DEPT.
TEST NO 839

BOEING VERTOL CH47 BOXES

FULL SCALE DATA/Q

W.T. TEST RUN 16

Q PSF	AA DEC	AY DEC	BODY AXES						SF/Q	WIND AXES	
			L/Q	D/Q	M/Q	YM/Q	RM/Q	(L/Q)		(D/Q)	
50.00	-10.0	.0	-46.0	139.38	-1220.4	35.3	-45.2	4.0	-21.1	145.25	
50.00	-10.0	3.9	-45.1	143.05	-1254.3	2.9	-280.1	90.6	-19.6	154.52	
50.00	-10.0	6.0	-45.1	143.09	-1262.4	-23.7	-324.8	128.1	-19.6	161.33	
50.00	-10.0	10.0	-47.2	141.50	-1378.7	-63.1	-377.0	194.1	-21.9	179.00	
50.00	-10.0	15.0	-42.4	136.62	-1604.1	46.2	-711.8	292.7	-18.0	212.83	
50.00	-10.0	20.0	-27.0	128.56	-1604.6	219.8	-1347.4	376.2	-4.2	252.03	
50.00	-10.0	30.0	36.6	92.95	-1719.5	50.8	-2918.4	531.1	52.2	339.32	
50.00	-10.0	.0	-46.0	139.86	-1220.0	39.8	-23.6	-3.8	-21.0	145.72	
50.00	-10.0	-6.0	-41.9	143.41	-1326.7	86.4	261.6	-123.6	-16.4	160.61	
50.00	-10.0	-10.0	-42.8	142.28	-1453.2	117.6	326.5	-190.4	-17.4	178.37	
50.00	-10.0	-15.0	-39.3	136.09	-1689.1	-3.2	537.9	-290.3	-15.1	211.19	
50.00	-10.0	-20.0	-24.9	156.16	-2046.0	306.6	261.3	-305.2	2.6	252.95	
50.00	-10.0	-30.0	44.4	86.57	-2033.3	-251.1	1069.8	-566.8	58.8	350.54	
30.00	-10.0	-60.0	-91.1	21.60	-1157.5	-1740.2	2481.1	-818.1	-86.0	726.98	
30.00	-10.0	-90.0	-15.6	-34.28	-7.3	1085.5	2211.0	-819.7	-21.3	819.65	

UNIVERSITY OF MARYLAND
WIND TUNNEL OPERATIONS DEPT.
TEST NO 839

BOEING VERVOL CH47 BOXES

FULL SCALE DATA/Q

W.T. TEST RUN 16

Q PSF	AA		AY		L/Q	D/Q	BODY AXES		RM/Q	SF/Q	WIND AXES	
	DEC	DEC	DEC	DEC			M/Q	YN/Q			(L/Q)	(D/Q)
50.00	-10.0	.0	.0	.0	-41.1	141.04	-1315.0	30.4	-48.3	8.3	-15.9	146.83
50.00	-4.0	.1	.1	.1	-20.5	131.01	-939.8	53.4	-40.8	7.1	-11.3	132.13
50.00	.0	.1	.1	.1	-7.8	122.55	-693.5	17.5	-42.6	7.4	-7.8	122.56
50.00	4.0	.1	.1	.1	10.1	117.00	-478.0	7.6	-43.8	9.0	1.9	117.44
50.00	8.0	.1	.1	.1	32.9	113.98	-277.0	46.0	-38.7	7.8	16.8	117.47
50.00	10.0	.1	.1	.1	46.0	114.00	-187.6	66.5	-35.4	6.6	25.5	120.26

UNIVERSITY OF MARYLAND
WIND TUNNEL OPERATIONS DEPT.
TEST NO 839

BOEING VERTOL CH47 BOXES

FULL SCALE DATA/Q

V.T. TEST RUN 17

Q PSF	AA DEC		AY DEC		L/Q	D/Q	BODY AXES M/Q		RM/Q	SF/Q	WIND AXES (L/Q) (D/Q)	
							YM/Q					
50.00	-10.0	-10.0	-15.0	-15.0	-36.1	136.04	-1604.4	-18.7	491.7	-283.7	-11.9	208.87
50.00	-10.0	-10.0	-10.0	-10.0	-38.2	141.71	-1449.1	84.2	337.7	-189.3	-13.1	176.84
50.00	-10.0	-10.0	-6.0	-6.0	-40.7	142.86	-1351.3	39.7	253.0	-114.9	-15.2	158.95
50.00	-10.0	-10.0	0	0	-40.9	142.32	-1256.6	33.2	-51.7	8.6	-15.6	147.26
50.00	-10.0	-10.0	-20.0	-20.0	-17.7	156.58	-1967.6	327.3	180.7	-299.0	9.7	250.06
50.00	-10.0	-10.0	-30.0	-30.0	46.9	87.56	-2015.5	-271.8	1010.4	-566.1	61.4	350.63
50.00	-10.0	-10.0	6.0	6.0	-42.2	143.44	-1307.4	10.9	-323.4	128.5	-16.6	161.20
50.00	-10.0	-10.0	10.0	10.0	-43.6	142.82	-1406.0	-49.6	-368.9	199.5	-18.2	180.62
50.00	-10.0	-10.0	13.0	13.0	-40.6	137.93	-1515.4	114.0	-791.8	288.7	-16.0	212.74

UNIVERSITY OF MARYLAND
WIND TUNNEL OPERATIONS DEPT.
TEST NO 839

BOEING VERTOL CH47 BOXES

FULL SCALE DATA/Q

W.T. TEST RUN 18

Q PSF	AA DEC	AY DEC	L/Q	D/Q	M/Q	Y/M/Q	RM/Q	SF/Q	WIND AXES (L/Q) (D/Q)
50.00	-10.0	.0	-57.2	149.05	-1094.1	-7.9	-15.4	1.7	-30.5 156.72
50.00	-4.0	.0	-28.2	137.83	-633.2	71.0	-9.8	-2.6	-18.6 139.47
50.00	4.0	.0	-12.4	128.68	-327.8	55.9	-36.7	3.8	-12.4 128.68
50.00	8.0	.0	11.9	117.20	-122.3	76.9	-37.5	4.1	3.7 117.75
50.00	10.0	.0	40.5	115.91	26.9	82.3	-21.9	1.4	23.9 120.41
50.00	10.0	.0	55.9	119.24	58.9	78.8	-18.9	.5	34.3 127.13

UNIVERSITY OF MARYLAND
WIND TUNNEL OPERATIONS DEPT.
TEST NO 839

BOEING VERTOL CH47 BOXES

FULL SCALE DATA/Q

W.T. TEST RUN 19

Q PSF	AA DEG	AY DEG	L/Q	D/Q	BODY AXES			RM/Q	SF/Q	WIND AXES	
					M/Q	YN/Q	(L/Q)			(D/Q)	
50.00	-10.0	0	-57.1	148.87	-1001.0	6.4	-18.1	.5	-30.3	156.52	
50.00	-10.0	6.0	-54.5	155.61	-1022.1	-137.2	-64.7	84.9	-26.6	170.69	
50.00	-10.0	10.0	-38.6	160.01	-1138.8	-263.4	-146.2	170.5	-10.2	191.40	
50.00	-10.0	15.0	-21.9	160.08	-1248.6	-181.1	-557.8	270.4	6.3	225.92	
50.00	-10.0	20.0	9.4	154.30	-1289.1	-104.8	-1318.2	359.6	36.1	264.22	
50.00	-10.0	30.0	68.7	120.49	-1509.9	-216.0	-2997.6	523.3	88.6	354.09	
50.00	-10.0	-6.0	-34.9	153.39	-1062.3	234.7	-12.4	-83.5	-27.4	168.44	
50.00	-10.0	-10.0	-32.3	160.97	-1260.7	261.1	164.4	-175.7	-3.8	192.14	
50.00	-10.0	-15.0	-20.6	160.82	-1373.5	247.1	293.9	-272.9	7.7	227.06	
50.00	-10.0	-20.0	7.7	154.66	-1528.4	134.7	483.2	-370.7	34.4	268.65	

UNIVERSITY OF MARYLAND
WIND TUNNEL OPERATIONS DEPT.
TEST NO 839

BOEING VERTOL CH47 BOXES

FULL SCALE DATA/Q

W.T. TEST RUN 20

Q PSF	AA DEG	AY DEG	L/Q	D/Q	BODY AXES M/Q	YM/Q	RM/Q	SF/Q	WIND AXES (L/Q) (D/Q)
50.00	-10.0	.0	-42.7	142.86	-1315.8	28.5	-32.9	1.7	-17.3 148.13
50.00	-4.0	.0	-19.3	133.31	-932.7	45.8	-28.8	.6	-10.0 134.34
50.00	.0	.0	-3.3	126.08	-677.8	62.6	-24.3	.8	-3.3 126.08
50.00	4.0	.0	13.5	121.08	-328.6	66.2	-16.2	.9	5.0 121.73
50.00	8.0	.0	32.3	116.89	-233.8	56.2	-12.7	1.5	15.7 120.26
50.00	10.0	.0	44.2	116.73	-128.9	68.5	-18.6	2.0	23.3 122.64

UNIVERSITY OF MARYLAND
WIND TUNNEL OPERATIONS DEPT.
TEST NO 839

BOEING VERTOL CH47 BOXES

FULL SCALE DATA/Q

W.T. TEST RUN 21

Q PSF	AA DEC	AY DEC	L/Q	D/Q	BODY AXES		RM/Q	SF/Q	WIND AXES	
					M/Q	YM/Q			(L/Q)	(D/Q)
50.00	-10.0	.0	-46.0	140.07	-1318.9	-7.8	-38.4	2.7	-21.0	145.93
50.00	-4.0	.0	-22.5	130.95	-943.8	15.9	-33.4	1.0	-13.3	132.20
50.00	.0	.0	-6.1	123.99	-695.8	34.9	-27.8	.5	-6.1	123.99
50.00	4.0	.0	11.2	118.30	-458.5	68.7	-15.6	-.3	2.9	118.80
50.00	8.0	.0	32.5	112.53	-234.5	54.1	-9.3	.6	16.5	115.96
50.00	10.0	.0	45.3	112.90	-142.9	39.7	-19.6	1.7	25.0	119.04

UNIVERSITY OF MARYLAND
WIND TUNNEL OPERATIONS DEPT.
TEST NO 839

BOEING VERTOL CH47 BOXES

FULL SCALE DATA/Q

W. T. TEST RUN 22

Q PSF	AA DEC	AY DEC	L/Q	D/Q	BODY AXES		RM/Q	SF/Q	WIND AXES (L/Q) (D/Q)	
					M/Q	YN/Q			(L/Q)	(D/Q)
50.00	-10.0	.0	-33.4	143.27	-1405.7	14.4	-24.7	.9	-8.1	146.91
50.00	-4.0	.0	-11.7	134.04	-1003.2	26.7	-20.9	.6	-2.3	134.53
50.00	.0	.0	2.8	126.81	-738.8	43.1	-17.0	.3	2.8	126.81
50.00	4.0	.0	18.3	120.72	-465.0	65.3	-8.2	1.3	9.9	121.70
50.00	8.0	.0	39.4	116.32	-244.5	44.4	-12.6	2.7	22.8	120.67
50.00	10.0	.0	52.1	117.03	-154.6	66.7	-17.2	2.0	31.0	124.30

UNIVERSITY OF MARYLAND
WIND TUNNEL OPERATIONS DEPT.
TEST NO 839

BOEING VERTOL CH47 BOXES

FULL SCALE DATA/Q

W.T. TEST RUN 23

Q PSF	AA		AY		L/Q	D/Q	BODY AXES		RM/Q	SF/Q	WIND AXES	
	DEC	DEC	DEC	DEC			M/Q	YM/Q			(L/Q)	(D/Q)
50.00	-10.0	.0	.0	.0	-46.7	132.10	-1296.2	29.5	-33.5	.9	-23.0	136.20
50.00	-4.0	.0	.0	.0	-23.1	122.93	-945.0	51.7	-23.8	-1.3	-14.5	124.26
50.00	.0	.0	.0	.0	-7.7	115.89	-704.0	59.7	-13.6	-1.4	-7.7	115.89
50.00	4.0	.0	.0	.0	9.0	110.21	-455.4	75.9	2.5	-1.8	1.3	110.57
50.00	8.0	.0	.0	.0	29.4	107.34	-231.1	22.6	-5.3	.9	14.2	110.39
50.00	10.0	.0	.0	.0	42.5	108.38	-166.9	25.4	-.6	-.1	23.0	114.11
50.00	12.0	.0	.0	.0	57.0	109.81	-79.7	23.1	.3	.0	32.9	119.26
50.00	15.0	.0	.0	.0	74.4	110.48	99.7	5.4	17.2	-2.4	43.3	125.96

UNIVERSITY OF MARYLAND
WIND TUNNEL OPERATIONS DEPT.
TEST NO 839

BOEING VERTOL CH47 BOXES

FULL SCALE DATA/Q

W. T. TEST RUN 24

Q PSF	AA DEC	AY DEC	L/Q	D/Q	BODY AXES		RM/Q	SF/Q	WIND AXES	
					M/Q	YM/Q			(L/Q)	(D/Q)
50.00	-10.0	.0	-49.8	129.74	-1254.0	34.3	-31.6	.9	-26.5	136.41
50.00	-8.0	.0	-41.5	127.34	-1145.7	37.8	-28.9	.9	-23.4	131.88
50.00	-4.0	.0	-25.7	121.49	-919.1	54.5	-25.8	-.6	-17.2	122.98
50.00	.0	.0	-10.4	114.68	-684.9	53.7	-18.5	-.6	-10.4	114.68
50.00	4.0	.0	5.5	108.46	-441.7	41.6	-7.0	.0	-2.0	108.58
50.00	8.0	.0	27.3	105.87	-201.1	32.2	-6.9	.8	12.3	108.63
50.00	10.0	.0	41.8	107.18	-128.8	29.3	-8.0	.1	22.5	112.81
50.00	15.0	.0	72.9	108.87	119.3	.9	20.1	-2.9	42.2	124.03

UNIVERSITY OF MARYLAND
WIND TUNNEL OPERATIONS DEPT.
TEST NO 839

BOEING VERTOL CH47 BOXES

FULL SCALE DATA/Q

W.T. TEST RUN 25

Q PSP	AA		AY		L/Q	D/Q	BODY AXES		RM/Q	SF/Q	WIND AXES	
	DEC	DEC	DEC	DEC			M/Q	YN/Q			(L/Q)	(D/Q)
50.00	-10.0	-10.0	.0	.0	-49.4	129.60	-1201.8	37.1	-35.0	1.2	-26.1	136.20
50.00	-10.0	-10.0	-6.0	-6.0	-60.9	131.83	-1265.1	27.5	238.2	-114.0	-37.1	151.55
50.00	-10.0	-10.0	-10.0	-10.0	-61.8	131.41	-1504.1	7.6	367.6	-189.9	-38.0	170.98
50.00	-10.0	-10.0	-15.0	-15.0	-51.1	126.64	-1731.4	-136.3	581.1	-299.8	-28.3	206.60
50.00	-10.0	-10.0	-20.0	-20.0	-30.5	118.64	-1763.2	-246.7	729.9	-379.3	-9.5	244.48
50.00	-10.0	-10.0	-30.0	-30.0	39.8	87.05	-1862.9	-343.9	965.6	-555.6	54.3	346.02
50.00	-10.0	-10.0	10.0	10.0	-62.3	132.28	-1453.8	-15.2	-399.4	190.5	-38.4	172.02
50.00	-10.0	-10.0	6.0	6.0	-63.8	132.09	-1254.3	16.7	-277.1	111.8	-39.9	152.08
50.00	-10.0	-10.0	15.0	15.0	-51.2	128.67	-1604.6	185.1	-948.2	287.7	-28.0	205.44
50.00	-10.0	-10.0	20.0	20.0	-33.0	120.68	-1444.9	390.8	-1497.7	358.6	-11.5	289.71

UNIVERSITY OF MARYLAND
WIND TUNNEL OPERATIONS DEPT.
TEST NO 839

BOEING VERTOL CH47 BOXES

FULL SCALE DATA/Q

W.T. TEST RUN 26

Q PSF	AA DEC	AY DEC	L/Q	D/Q	BODY AXES			RM/Q	SF/Q	WIND AXES	
					M/Q	YM/Q	(L/Q)			(D/Q)	
50.00	-10.0	.0	-59.6	123.01	-1241.3	36.1	-8.9	-4.1	-37.4	131.49	
50.00	-4.0	.0	-34.8	115.90	-908.6	49.6	-11.2	-4.7	-26.6	118.04	
50.00	.0	.0	-16.6	110.22	-660.2	50.5	-9.8	-4.1	-16.6	110.22	
50.00	4.0	.0	4.2	105.37	-408.8	29.9	.4	-2.9	-3.2	105.41	
50.00	8.0	.0	28.9	102.03	-150.2	13.3	7.0	-2.0	14.5	105.06	
50.00	10.0	.0	42.9	101.51	-43.0	7.9	6.5	-1.9	24.6	107.40	
50.00	12.0	.0	53.3	101.17	37.5	1.9	13.6	-2.3	31.1	110.04	
50.00	15.0	.0	70.2	98.84	247.0	.9	32.4	-6.1	42.2	113.64	
50.00	20.0	.0	110.9	95.49	540.7	25.3	41.9	-6.8	71.6	127.65	

UNIVERSITY OF MARYLAND
WIND TUNNEL OPERATIONS DEPT.
TEST NO 839

BOEING VERTOL CH47 BOXES

FULL SCALE DATA/Q

W.T. TEST RUN 27

Q PSF	AA DEG	AY DEG	L/Q	D/Q	BODY AXES		RM/Q	SF/Q	WIND AXES	
					M/Q	YM/Q			(L/Q)	(D/Q)
50.00	-10.0	.0	-59.6	123.63	-1204.1	36.3	-9.9	-4.1	-37.2	132.11
50.00	-10.0	6.0	-67.6	124.87	-1196.7	120.3	-294.3	108.8	-44.9	145.34
50.00	-10.0	10.0	-68.6	123.64	-1383.1	135.2	-424.5	186.4	-46.1	164.01
50.00	-10.0	15.0	-59.7	121.71	-1443.1	299.6	-763.2	269.0	-37.6	195.42
50.00	-10.0	20.0	-35.8	118.12	-1280.1	429.8	-1358.0	350.1	-14.7	234.89
50.00	-10.0	30.0	25.9	91.03	-1125.0	459.3	-2811.5	512.4	41.3	329.89
50.00	-10.0	-10.0	-64.0	127.91	-1432.2	-47.1	375.2	-187.3	-49.8	167.56
50.00	-10.0	-15.0	-54.2	125.37	-1604.0	-198.6	565.6	-280.4	-31.6	200.91
50.00	-10.0	-20.0	-27.6	120.42	-1614.1	-248.1	661.4	-368.3	-6.3	241.89
50.00	-10.0	-6.0	-63.4	127.24	-1273.4	-37.0	250.7	-112.0	-40.3	147.28

UNIVERSITY OF MARYLAND
WIND TUNNEL OPERATIONS DEPT.
TEST NO 839

BOEING VERTOL CH47 BOXES

FULL SCALE DATA/Q

W.T. TEST RUN 28

Q PSF	AA		AY		L/Q	D/Q	BODY AXES		RM/Q	SF/Q	WIND AXES	
	DEC	DEC	DEC	DEC			M/Q	YM/Q			(L/Q)	(D/Q)
50.00	-20.0	.0	-126.5	122.94	-1638.0	72.3	-52.6	-2.3	-76.8	158.78		
50.00	-10.0	.0	-74.3	115.65	-1152.2	29.5	-26.7	-1.8	-53.1	126.80		
50.00	.0	.0	-19.7	104.74	-597.3	77.5	-42.9	-1.8	-19.7	104.74		
50.00	4.0	.0	12.2	104.28	-454.2	42.8	-34.3	.3	4.9	104.87		
50.00	8.0	.0	40.8	105.57	-308.4	25.1	-28.0	1.5	25.7	110.22		
50.00	10.0	.0	56.0	104.64	-191.4	16.0	-24.4	1.4	37.0	112.78		

UNIVERSITY OF MARYLAND
WIND TUNNEL OPERATIONS DEPT.
TEST NO 839

BOEING VERTOL CH47 BOXES

FULL SCALE DATA/Q

W.T. TEST RUN 29

Q PSF	AA		AY DEC	L/Q	D/Q	BODY AXES		RM/Q	SF/Q	WIND AXES	
	DEC	DEC				M/Q	YM/Q			(L/Q)	(D/Q)
50.00	-10.0		.0	-70.9	116.74	-1151.8	25.3	-20.6	-3.5	-49.5	127.27
50.00	-6.0		.0	-50.9	112.49	-946.3	32.2	-19.8	-3.8	-38.9	117.20
50.00	-2.0		.0	-30.1	107.57	-722.8	43.9	-17.9	-4.1	-26.4	108.56
50.00	.0		.0	-19.6	105.77	-602.2	51.4	-14.6	-5.1	-19.6	105.77
50.00	2.0		.0	-7.2	104.33	-468.8	53.6	-15.5	-4.7	-10.9	104.01
50.00	4.0		-1.1	5.7	103.37	-358.8	44.9	-7.1	-4.7	-1.5	103.53
50.00	6.0		-1.1	22.5	104.07	-318.6	13.9	5.1	-3.8	11.5	105.86
50.00	10.0		.0	50.3	104.49	-147.1	6.9	-2.0	-2.0	31.4	111.63
50.00	12.0		.0	63.2	102.88	-30.9	-3.3	-1.8	-1.5	40.4	113.78

UNIVERSITY OF MARYLAND
WIND TUNNEL OPERATIONS DEPT.
TEST NO 839

BOEING VERTOL CH47 BOXES

FULL SCALE DATA/Q

W. T. TEST RUN 30

Q PSF	AA DEC	AY DEC	L/Q	D/Q	BODY AXES		RM/Q	SF/Q	WIND AXES	
					M/Q	YM/Q			(L/Q)	(D/Q)
50.00	-10.0	.0	-67.5	118.47	-1168.3	17.1	-20.0	-2.4	-46.0	128.40
50.00	-6.0	.0	-49.4	114.60	-969.3	30.0	-17.0	-3.1	-37.1	119.13
50.00	-2.0	.0	-29.6	109.27	-742.3	46.8	-18.4	-2.4	-25.7	110.23
50.00	.0	.0	-19.3	106.93	-620.8	41.9	-12.9	-3.5	-19.3	106.93
50.00	2.0	.0	-8.1	105.37	-490.1	40.7	-7.6	-3.5	-11.8	105.02
50.00	4.0	.0	4.1	104.17	-373.8	35.9	-2.6	-3.2	-3.2	104.20
50.00	6.0	.0	17.4	103.17	-243.5	29.5	4.1	-3.5	6.5	104.42
50.00	10.0	.0	47.0	103.58	-98.0	5.9	4.0	-1.8	28.3	110.17
50.00	12.0	.0	59.1	102.52	13.3	3.8	3.0	-1.8	36.5	112.56

UNIVERSITY OF MARYLAND
WIND TUNNEL OPERATIONS DEPT.
TEST NO 839

BOEING VERTOL CH47 BOXES

FULL SCALE DATA/Q

W.T. TEST RUN 31

Q PSF	AA DEC	AY DEC	L/Q	D/Q	BODY AXES		RM/Q	SF/Q	WIND AXES	
					M/Q	YM/Q			(L/Q)	(D/Q)
50.00	-10.0	.0	-65.5	112.86	-1066.0	22.0	-23.7	-1.7	-44.9	122.52
50.00	-6.0	.0	-44.7	108.33	-882.4	42.2	-22.1	-1.5	-33.2	112.41
50.00	-2.0	.0	-24.9	103.76	-654.0	51.2	-22.2	-1.7	-21.2	104.56
50.00	.0	.0	-14.5	102.36	-537.7	49.0	-20.1	-1.0	-14.5	102.36
50.00	2.0	.0	-3.3	101.24	-423.3	49.9	-18.6	-1.4	-6.8	101.07
50.00	4.0	.0	9.2	101.69	-349.5	40.4	-14.3	-1.2	2.0	102.08
50.00	6.0	.0	25.0	103.13	-305.1	22.1	-4.5	-1.0	14.1	105.18
50.00	10.0	.0	53.8	102.43	-124.8	7.8	5.9	-2.2	35.2	110.22
50.00	12.0	.0	67.6	100.80	-31.5	.5	6.0	-1.8	45.2	112.65

UNIVERSITY OF MARYLAND
WIND TUNNEL OPERATIONS DEPT.
TEST NO B39

BOEING VERTOL CH47 BOXES

FULL SCALE DATA/Q

W.T. TEST RUN 32

Q PSF	AA DEC	AY DEC	L/Q	D/Q	M/Q	YM/Q	RM/Q	SF/Q	WIND AXES (L/Q)	WIND AXES (D/Q)
50.00	-10.0	0	-66.0	112.48	-984.2	26.1	-25.5	-1.0	-45.4	122.23
50.00	-10.0	-6.0	-66.7	119.07	-1152.8	-108.9	224.7	-100.4	-45.1	138.64
50.00	-10.0	-10.0	-63.8	120.15	-1280.9	-223.3	399.1	-172.0	-42.0	157.31
50.00	-10.0	-15.0	-54.0	115.59	-1386.8	-370.7	606.6	-272.2	-33.2	189.47
50.00	-10.0	-20.0	-36.8	112.90	-1445.7	-519.7	774.9	-357.0	-16.6	232.59
50.00	-10.0	-30.0	15.5	86.63	-1480.3	-716.0	934.5	-528.5	30.3	335.77
50.00	-10.0	0	-66.6	113.03	-988.9	26.7	-23.9	1.7	-46.0	122.88
50.00	-10.0	6.0	-70.6	117.86	-1083.5	160.7	-265.0	99.2	-49.0	137.98
50.00	-10.0	10.0	-66.3	118.57	-1218.9	243.7	-418.5	170.4	-44.7	155.92
50.00	-10.0	15.0	-55.2	114.22	-1278.9	473.9	-784.4	260.5	-34.6	185.33
50.00	-10.0	20.0	-37.7	111.42	-1198.6	630.2	-1409.9	340.4	-17.8	225.66

UNIVERSITY OF MARYLAND
WIND TUNNEL OPERATIONS DEPT.
TEST NO 839

BOEING VERTOL CH47 BOXES

FULL SCALE DATA/Q

W.T. TEST RUN 33

Q PSF	AA DEC		AY DEC		L/Q	D/Q	BODY AXES M/Q			RM/Q	SF/Q	WIND AXES (L/Q) (D/Q)	
							M/Q	YM/Q				(L/Q)	(D/Q)
50.00	-10.0	.0	.0	.0	-57.4	116.33	-1093.4	22.2	-7.9	-4.9	-36.4	124.53	
50.00	-6.0	.0	.0	.0	-40.2	111.98	-891.7	36.4	-8.4	-5.0	-28.3	115.57	
50.00	-2.0	.0	.0	.0	-23.3	106.31	-676.5	53.8	-5.9	-3.8	-19.6	107.06	
50.00	.0	.0	.0	.0	-14.3	103.54	-551.8	49.0	-3.0	-3.7	-14.3	103.54	
50.00	2.0	.0	.0	.0	-4.0	101.68	-416.7	41.4	-7	-3.6	-7.6	101.40	
50.00	4.0	.0	.0	.0	6.9	100.33	-302.3	42.0	5.0	-3.3	-1	100.57	
50.00	6.0	.0	.0	.0	18.8	99.15	-190.8	31.2	11.6	-3.7	8.3	100.57	
50.00	10.0	.0	.0	.0	47.0	100.82	-48.9	15.1	12.3	-3.7	28.8	107.46	
50.00	12.0	.0	.0	.0	57.9	99.57	61.2	11.9	18.5	-4.5	36.0	109.44	

UNIVERSITY OF MARYLAND
WIND TUNNEL OPERATIONS DEPT.
TEST NO 839

BOEING VERTOL C147 BOXES

FULL SCALE DATA/Q

W.T. TEST RUN 35

Q PSF	AA		AY		L/Q	D/Q	BODY AXES		RM/Q	SF/Q	WIND AXES	
	DEC	DEC	DEC	DEC			M/Q	Y/M/Q			(L/Q)	(D/Q)
50.00	-10.0		.0		-57.3	116.19	-1043.6	23.8	-10.0	-4.1	-36.2	124.36
50.00	-10.0		-6.0		-61.7	120.65	-1193.2	-41.0	222.8	-113.6	-39.8	140.70
50.00	-10.0		-10.0		-58.4	120.61	-1383.4	-85.6	385.6	-194.7	-36.6	160.77
50.00	-10.0		-15.0		-48.5	116.37	-1494.5	-247.4	553.9	-267.7	-27.5	193.27
50.00	-10.0		-20.0		-25.7	110.93	-1532.2	-378.8	656.1	-370.6	-6.0	233.61
50.00	-10.0		-30.0		33.2	82.31	-1619.9	-586.7	833.9	-541.1	47.0	335.74
50.00	-10.0		6.0		-94.9	284.50	-2295.7	211.3	-359.5	124.7	-44.0	308.07
50.00	-10.0		10.0		-88.6	267.45	-2354.3	297.5	-554.0	212.0	-40.8	311.49
50.00	-10.0		15.0		-71.6	235.19	-2211.0	509.9	-1097.1	312.1	-29.7	316.52
50.00	-10.0		20.0		-45.6	198.97	-1843.7	678.6	-1689.1	387.5	-10.4	324.10

UNIVERSITY OF MARYLAND
WIND TUNNEL OPERATIONS DEPT.
TEST NO 839

BOEING VERTOL CH47 BOXES

FULL SCALE DATA/Q

V.T. TEST RUN 36

Q PSF	AA DEC	AY DEC	L/Q	D/Q	BODY AXES			RM/Q	SF/Q	WIND AXES	
					M/Q	YN/Q	(L/Q)			(D/Q)	
50.00	-10.0	.0	-64.2	114.29	-1059.7	22.2	-11.9	-3.6	-43.4	123.70	
50.00	-6.0	.0	-43.6	109.48	-869.7	42.1	-15.1	-3.3	-31.9	113.43	
50.00	-2.0	.0	-24.8	104.73	-636.2	58.2	-10.0	-3.1	-21.1	105.54	
50.00	.0	.0	-15.4	103.04	-503.8	53.6	-10.4	-3.8	-15.4	103.04	
50.00	2.0	.0	-4.3	101.98	-393.0	53.4	-6.6	-4.4	-7.8	101.77	
50.00	4.0	.0	9.1	101.46	-311.3	33.7	3.5	-3.3	2.0	101.85	
50.00	6.0	.0	24.2	103.08	-257.3	17.8	11.0	-3.2	13.3	105.05	
50.00	10.0	.0	49.8	102.78	-60.9	9.8	20.5	-4.6	31.2	109.88	
50.00	12.0	.0	63.1	101.23	53.9	4.3	26.8	-4.7	40.7	112.14	

UNIVERSITY OF MARYLAND
WIND TUNNEL OPERATIONS DEPT.
TEST NO 839

BOEING VERTOL CH47 BOXES

FULL SCALE DATA/Q

W.T. TEST RUN 37

Q PSF	AA DEG	AY DEC	L/Q	D/Q	BODY AXES		RM/Q	SF/Q	WIND AXES	
					M/Q	YM/Q			(L/Q)	(D/Q)
50.00	-20.0	.0	-113.3	119.34	-1571.7	73.7	-32.1	-6.0	-65.7	150.90
50.00	-15.0	.0	-86.8	117.07	-1323.8	16.1	-19.1	-3.8	-53.5	135.54
50.00	-12.0	-.1	-73.2	115.76	-1187.3	14.5	-9.6	-3.9	-47.5	128.45
50.00	-10.0	.0	-64.1	114.18	-1085.9	26.7	-11.5	-4.0	-43.3	123.57
50.00	-8.0	.0	-52.9	111.83	-989.9	36.0	-11.2	-3.6	-36.9	118.11
50.00	-6.0	.0	-43.9	109.54	-893.5	44.3	-12.2	-3.7	-32.3	113.54
50.00	-4.0	.0	-33.8	106.89	-789.2	56.7	-13.2	-3.6	-26.2	108.94
50.00	-2.0	.0	-25.3	104.63	-659.3	66.0	-9.6	-3.6	-21.6	105.45
50.00	.0	.0	-15.1	103.00	-536.3	65.7	-8.4	-3.8	-15.1	103.00
50.00	2.0	.0	-4.3	101.65	-413.4	56.1	-1.8	-4.5	-7.8	101.44
50.00	4.0	.0	9.0	101.17	-340.7	37.0	7.4	-3.8	1.9	101.56
50.00	6.0	.0	24.1	102.84	-285.0	22.4	15.1	-3.5	13.2	104.79
50.00	8.0	.0	38.2	103.42	-205.0	7.4	24.8	-4.6	23.4	107.72
50.00	10.0	.0	50.1	102.68	-86.2	7.6	22.7	-4.7	31.5	109.81
50.00	12.0	.0	62.8	101.11	23.1	4.8	27.0	-4.6	40.4	111.96
50.00	15.0	.0	87.6	100.32	193.4	-22.6	48.8	-7.8	58.6	119.56
50.00	20.0	.0	120.4	99.98	568.2	14.7	48.5	-9.0	79.0	135.14

UNIVERSITY OF MARYLAND
WIND TUNNEL OPERATIONS DEPT.
TEST NO 839

BOEING VERTOL CH47 BOXES

FULL SCALE DATA/Q

W.T. TEST RUN 38

Q FSF	AA DEC	AY DEC	L/Q	D/Q	BODY AXES			RM/Q	SF/Q	WIND AXES	
					M/Q	YM/Q	(L/Q)			(D/Q)	
50.00	-10.0	0	-64.2	113.95	-1024.5	33.0	-13.2	-2.6	-43.4	123.35	
50.00	-10.0	2.0	-65.1	114.09	-1025.9	142.1	-134.2	28.5	-44.3	124.58	
50.00	-10.0	4.0	-65.4	115.80	-1056.2	148.4	-210.5	66.4	-44.3	129.72	
50.00	-10.0	6.0	-67.5	117.68	-1123.3	147.0	-271.5	101.8	-46.1	137.56	
50.00	-10.0	8.0	-66.8	118.46	-1211.8	145.2	-343.9	139.1	-45.2	146.37	
50.00	-10.0	10.0	-63.5	117.56	-1254.9	184.3	-416.1	173.6	-42.1	155.02	
50.00	-10.0	15.0	-50.5	112.50	-1341.3	346.2	-899.2	272.2	-30.2	185.92	
50.00	-10.0	20.0	-34.2	109.06	-1298.3	504.0	-1515.7	350.0	-14.7	226.21	
50.00	-10.0	30.0	9.0	78.78	-1500.3	262.1	-3032.4	493.8	22.5	312.72	
50.00	-10.0	0	-64.2	114.46	-1027.2	27.5	-11.7	-5.5	-43.4	123.68	
50.00	-10.0	-2.0	-64.7	115.49	-1021.2	-71.1	94.5	-37.7	-43.6	126.21	
50.00	-10.0	-4.0	-64.7	117.91	-1084.7	-75.6	167.3	-69.9	-43.3	131.92	
50.00	-10.0	-6.0	-65.4	120.49	-1199.9	-83.0	236.6	-105.6	-43.5	140.34	
50.00	-10.0	-8.0	-64.3	121.25	-1297.5	-91.4	320.9	-140.9	-42.2	148.90	
50.00	-10.0	-10.0	-61.2	120.71	-1356.4	-173.0	419.6	-178.4	-39.3	158.52	
50.00	-10.0	-15.0	-49.5	115.70	-1492.3	-292.9	601.6	-283.4	-28.7	191.72	
50.00	-10.0	-19.9	-31.5	111.62	-1573.4	-393.9	735.8	-367.9	-11.6	233.73	
50.00	-10.0	-30.0	22.4	83.73	-1681.9	-588.6	938.8	-544.8	36.6	340.40	
30.00	-10.0	-60.0	-112.7	22.15	-1087.9	-1865.6	2202.7	-794.3	-107.1	708.57	
30.00	-10.0	-90.0	-11.6	-30.56	-213.3	1077.8	1832.1	-835.1	-18.1	835.09	
30.00	-10.0	60.0	-105.1	23.82	-305.7	2069.5	-2519.7	786.0	-99.4	701.48	
30.00	-10.0	90.0	-4.3	-46.80	-97.1	-858.6	-1964.7	820.8	-12.4	820.84	

UNIVERSITY OF MARYLAND
WIND TUNNEL OPERATIONS DEPT.
TEST NO 839

BOEING VERVOL CH47 BOXES

FULL SCALE DATA/Q

W.T. TEST RUN 41

Q PSF	AA DEC	AY DEC	L/Q	D/Q	BODY AXES		RM/Q	SF/Q	WIND AXES	
					M/Q	YM/Q			(L/Q)	(D/Q)
50.00	-10.0	.0	-65.9	47.75	-846.3	47.4	-13.7	-1.4	-56.6	58.46
50.00	-6.0	.0	-44.0	47.44	-660.1	69.8	-14.0	-.6	-38.8	51.78
50.00	-2.0	.0	-24.4	48.15	-348.7	93.0	-20.6	.5	-22.7	48.97
50.00	.0	.0	-13.6	48.18	-199.9	86.5	-22.7	-.1	-13.6	48.18
50.00	2.0	.0	-2.0	48.00	-27.1	85.7	-21.6	-.6	-3.7	47.90
50.00	4.0	.0	9.5	47.52	112.7	75.4	-15.3	-.4	6.1	48.06
50.00	6.0	.0	21.3	46.71	287.2	66.8	-11.1	.5	16.3	48.68
50.00	10.0	.0	44.0	45.20	621.5	51.6	-11.1	.9	35.5	52.15
50.00	12.0	.0	56.7	44.09	804.6	51.7	-15.1	1.7	46.3	54.92

UNIVERSITY OF MARYLAND
WIND TUNNEL OPERATIONS DEPT.
TEST NO 839

BOEING VERTOL CH47 BOXES

FULL SCALE DATA/Q

V.T. TEST RUN 42

Q PSP	AA DEC	AY DEC	L/Q	D/Q	BODY AXES		RN/Q	SF/Q	WIND AXES	
					M/Q	YM/Q			(L/Q)	(D/Q)
50.00	-20.0	.0	-119.1	116.04	-1699.2	37.7	-32.5	-2.6	-72.2	149.76
50.00	-15.0	.0	-92.1	113.76	-1435.7	28.8	-17.2	-1.0	-59.5	133.72
50.00	-12.0	.0	-74.6	112.49	-1286.4	42.4	-15.4	-.4	-49.5	125.53
50.00	-10.0	.0	-63.0	111.13	-1174.9	50.3	-14.5	-.5	-42.8	120.38
50.00	-8.0	.0	-51.4	110.26	-1057.3	55.2	-14.4	-.4	-35.6	116.34
50.00	-6.0	.0	-41.3	109.03	-932.7	63.0	-17.5	-.4	-29.7	112.76
50.00	-4.0	.0	-30.9	108.05	-819.3	82.5	-26.6	.4	-23.3	109.94
50.00	-2.0	.0	-20.0	107.31	-704.2	87.5	-24.4	.1	-16.3	107.94
50.00	.0	.0	-8.2	106.32	-577.7	78.7	-25.2	-1.0	-8.2	106.32
50.00	2.0	.0	4.7	105.41	-443.0	69.3	-20.4	-.9	1.0	105.51
50.00	4.0	.0	17.2	104.77	-334.3	56.8	-16.5	-.1	9.9	105.72
50.00	6.0	.0	30.6	103.66	-35.4	32.6	-2.4	-.5	19.6	106.29
50.00	8.0	.0	44.1	103.27	-135.9	29.2	2.0	-.5	29.3	108.40
50.00	10.0	.0	57.6	103.60	-36.7	28.4	1.9	-1.0	38.8	112.04
50.00	12.0	.0	71.1	103.61	65.1	35.6	2.6	-.1	48.0	116.12
50.00	15.0	.0	89.7	102.79	232.5	-1.7	16.2	-3.1	60.0	122.59
50.00	20.0	.0	127.8	100.53	584.6	21.5	-4.6	-1.0	85.8	138.19

UNIVERSITY OF MARYLAND
WIND TUNNEL OPERATIONS DEPT.
TEST NO 839

BOEING VERTOL CH47 BOXES

FULL SCALE DATA/Q

V.T. TEST RUN 43

Q PSF	AA DEC	AY DEC	L/Q	D/Q	M/Q	YN/Q	RM/Q	SF/Q	(L/Q)	WIND AXES (D/Q)
50.00	-10.0	.0	-63.0	111.06	-1136.4	50.8	-14.0	.1	-42.8	120.31
50.00	-10.0	2.0	-63.8	113.53	-1163.9	103.7	-27.2	19.8	-43.1	123.51
50.00	-10.0	4.0	-64.1	117.81	-1188.4	124.7	-24.2	43.1	-42.6	129.84
50.00	-10.0	6.0	-62.7	122.94	-1222.5	132.4	-15.7	69.2	-40.4	138.48
50.00	-10.0	8.0	-59.8	128.59	-1328.7	136.9	-6.5	98.0	-36.6	149.32
50.00	-10.0	10.0	-55.6	131.93	-1431.5	139.7	-44.1	125.9	-31.9	159.32
50.00	-10.0	14.9	-44.5	135.11	-1644.6	229.9	-204.1	210.4	-20.4	190.16
50.00	-10.0	20.0	-29.5	132.54	-1792.8	259.2	-898.7	285.4	-6.0	225.08
50.00	-10.0	30.1	-26.2	111.53	-1789.1	242.5	-2291.1	418.9	-6.4	309.00
50.00	-10.0	.0	-62.9	112.13	-1138.7	57.3	-42.5	-2.9	-42.5	121.36
50.00	-10.0	-2.0	-63.9	114.59	-1177.9	15.5	-46.0	-23.2	-43.0	124.67
50.00	-10.0	-4.0	-62.7	117.77	-1237.5	2.5	-50.9	-47.9	-41.3	129.91
50.00	-10.0	-6.0	-61.3	122.97	-1316.1	-21.3	-42.8	-72.4	-39.0	138.60
50.00	-10.0	-8.0	-57.9	128.40	-1407.8	-44.0	-41.9	-96.2	-34.7	148.56
50.00	-10.0	-10.0	-53.7	132.61	-1521.0	-73.2	-10.0	-125.9	-29.8	159.65
50.00	-10.0	-15.0	-42.6	136.87	-1732.2	-142.1	107.5	-208.0	-18.2	191.17
50.00	-10.0	-20.0	-27.3	137.06	-1907.9	-209.5	240.3	-292.2	-3.1	231.23
50.00	-10.0	-30.0	-17.3	142.17	-2303.8	-135.8	278.4	-404.6	7.7	326.14
30.00	-10.0	-60.1	-231.3	52.60	-1511.6	-1271.1	1990.9	-697.3	-218.7	650.35
30.00	-10.0	-90.0	-258.9	-13.08	-115.5	1219.9	1971.9	-701.2	-257.3	701.23

UNIVERSITY OF MARYLAND
WIND TUNNEL OPERATIONS DEPT.
TEST NO 839

BOEING VERTOL CH47 BOXES

FULL SCALE DATA/Q

W.T. TEST RUN 44

Q PSF	AA DEC	AY DEC	L/Q	D/Q	BODY AXES		RM/Q	SF/Q	WIND AXES	
					M/Q	YM/Q			(L/Q)	(D/Q)
50.00	-20.0	.0	-115.3	101.70	-2017.8	45.0	-53.8	-2.2	-73.6	135.01
50.00	-15.0	.0	-86.6	99.50	-1661.6	39.8	-32.8	-1.9	-57.9	118.52
50.00	-12.0	.0	-69.7	97.13	-1455.9	47.9	-29.6	-1.3	-48.0	109.50
50.00	-10.0	.0	-57.2	95.38	-1323.0	48.4	-27.1	-.3	-39.8	103.87
50.00	-8.0	.0	-45.2	93.72	-1205.1	52.3	-29.2	.6	-31.7	99.17
50.00	-6.0	.0	-34.4	91.86	-1081.1	56.4	-29.7	1.2	-24.6	94.95
50.00	-4.0	.0	-23.7	90.73	-945.2	59.3	-28.5	1.7	-17.3	92.16
50.00	-2.0	.0	-13.4	89.67	-738.0	61.7	-28.7	1.3	-10.2	90.09
50.00	.0	.0	-2.6	89.22	-674.9	66.5	-30.5	.8	-2.6	89.22
50.00	2.0	.0	9.3	89.43	-527.4	52.0	-24.7	.4	6.1	89.70
50.00	4.0	.0	21.6	89.99	-384.3	43.0	-19.0	1.3	15.2	91.28
50.00	6.0	.0	33.5	91.08	-238.5	27.5	-14.6	1.8	23.8	94.08
50.00	8.0	.0	45.6	92.07	-100.5	28.0	-15.3	2.3	32.4	97.52
50.00	10.0	.0	58.2	93.47	47.8	29.8	-14.0	1.5	41.1	102.16
50.00	12.0	.0	71.3	94.29	202.4	42.6	-18.5	2.4	50.2	107.06
50.00	15.0	.0	88.3	93.57	417.6	-17.8	-5.5	-1.8	61.1	113.23
50.00	20.0	.0	118.4	91.38	863.4	.3	-5.9	1.3	80.0	126.36

UNIVERSITY OF MARYLAND
WIND TUNNEL OPERATIONS DEPT.
TEST NO 839

BOEING VERTOL CH47 BOXES

FULL SCALE DATA/Q

W.T. TEST RUN 45

Q	AA DEC	AY DEC	L/Q	D/Q	M/Q	YM/Q	RM/Q	SF/Q	(L/Q)	WIND AXES (D/Q)
50.00	-10.0	.0	-57.3	95.48	-1288.9	58.8	-23.3	.6	-39.8	103.97
50.00	-10.0	-6.0	-51.0	100.56	-1400.2	-127.6	13.2	-69.6	-32.8	114.57
50.00	-10.0	-10.0	-47.7	103.13	-1543.1	-226.0	31.9	-120.7	-29.1	129.14
50.00	-10.0	-15.0	-46.6	102.75	-1663.1	-346.7	118.9	-189.9	-28.0	154.70
50.00	-10.0	-20.0	-41.4	99.70	-1785.9	-354.8	205.6	-257.7	-23.4	190.58
50.00	-10.0	-30.0	-50.9	81.63	-1908.7	-478.8	409.5	-402.1	-36.0	278.31
50.00	-10.0	.0	-58.2	95.63	-1285.6	55.6	-19.2	1.3	-40.7	104.28
50.00	-10.0	6.0	-55.2	101.73	-1390.7	218.3	-64.8	72.9	-36.7	116.80
50.00	-10.0	10.0	-52.5	104.16	-1478.3	302.2	-86.2	123.9	-33.7	131.52
50.00	-10.0	15.0	-48.7	102.42	-1575.4	440.5	-315.4	194.0	-30.2	155.81
50.00	-10.0	20.0	-43.2	99.27	-1540.5	467.2	-880.1	262.8	-25.3	188.80

UNIVERSITY OF MARYLAND
WIND TUNNEL OPERATIONS DEPT.
TEST NO 839

BOEING VERTOL CH47 BOXES

FULL SCALE DATA/Q

W.T. TEST RUN 46

Q PSP	AA DEC	AY DEC	L/Q	D/Q	BODY AXES		RM/Q	SF/Q	WIND AXES	
					M/Q	YM/Q			(L/Q)	(D/Q)
50.00	-10.0	.0	-66.4	114.25	-1048.8	50.0	-31.7	1.2	-45.6	124.04
50.00	-6.0	.0	-45.4	109.87	-863.7	68.3	-31.3	.5	-33.7	114.01
50.00	-2.0	.0	-26.3	105.00	-636.5	80.9	-27.9	.0	-22.7	105.86
50.00	.0	.0	-17.4	103.26	-511.7	77.3	-27.9	-.1	-17.4	103.26
50.00	2.0	.0	-6.3	101.62	-383.4	67.3	-24.1	-.1	-9.9	101.34
50.00	4.0	.0	7.6	101.64	-295.6	50.9	-22.1	1.0	.5	101.93
50.00	6.0	.0	23.1	103.43	-259.3	36.0	-10.4	.8	12.2	105.28
50.00	10.0	.0	52.3	104.68	-98.4	37.1	-2.0	-.3	33.3	112.17
50.00	12.0	.0	65.3	103.37	13.7	21.8	3.9	-.8	42.4	114.69

UNIVERSITY OF MARYLAND
WIND TUNNEL OPERATIONS DEPT.
TEST NO 839

BOEING VERTOL CH47 BOXES

FULL SCALE DATA/Q

W.T. TEST RUN 47

Q	PSF	AA DEC	AY DEC	L/Q	D/Q	M/Q	YM/Q	RM/Q	SF/Q	(L/Q)	WIND AXES (D/Q)
50.00		-10.0	.0	-64.5	115.74	-1058.9	39.7	-49.0	4.6	-43.4	125.17
50.00		-6.0	.0	-42.8	111.33	-888.2	59.5	-45.5	3.2	-31.0	115.20
50.00		-2.0	.0	-24.4	106.94	-661.6	64.1	-43.6	2.9	-20.6	107.72
50.00		.0	.0	-16.9	104.64	-504.0	67.1	-45.7	3.3	-16.9	104.64
50.00		2.0	.0	-5.5	103.17	-399.2	53.9	-35.4	2.4	-9.1	102.91
50.00		4.0	.0	7.8	102.71	-313.8	42.0	-27.5	2.7	.6	103.00
50.00		6.0	.0	23.7	104.21	-270.3	39.6	-16.9	2.3	12.7	106.11
50.00		10.0	.0	52.1	106.66	-112.3	35.7	-6.8	.6	32.8	114.09
50.00		12.0	.0	64.3	106.61	-8.1	22.8	-6.0	.8	40.7	117.64

UNIVERSITY OF MARYLAND
WIND TUNNEL OPERATIONS DEPT.
TEST NO 839

BOEING VERTOL CH47 BOXES

FULL SCALE DATA/Q

W.T. TEST RUN 48

Q PSF	AA DEG	AY DEG	L/Q	D/Q	BODY AXES		RM/Q	SF/Q	WIND AXES	
					M/Q	YM/Q			(L/Q)	(D/Q)
50.00	-10.0	.0	-67.5	114.23	-1093.2	52.9	-42.9	3.1	-46.6	124.21
50.00	-6.0	.0	-47.3	109.82	-899.5	68.4	-37.8	2.8	-35.6	114.16
50.00	-2.0	.0	-28.3	104.90	-686.3	65.9	-39.8	2.7	-24.6	105.82
50.00	.0	.0	-18.8	103.01	-560.0	60.9	-45.1	3.1	-18.8	103.01
50.00	2.0	.0	-5.5	102.14	-445.1	46.8	-36.9	3.2	-9.1	101.89
50.00	4.0	.0	9.1	102.87	-391.0	41.1	-24.8	1.9	1.9	103.26
50.00	6.0	.0	23.6	105.39	-346.9	45.9	-16.0	2.0	12.4	107.28
50.00	10.0	.0	50.6	108.84	-179.3	43.8	-11.3	1.5	31.0	115.98
50.00	12.0	.0	63.5	109.14	-75.1	32.9	-2.6	.5	39.4	119.96

UNIVERSITY OF MARYLAND
WIND TUNNEL OPERATIONS DEPT.
TEST NO 839

BOEING VERTOL CH47 BOXES

FULL SCALE DATA/Q

V.T. TEST RUN 49

Q PSF	AA DEC	AY DEC	L/Q	D/Q	M/Q	YM/Q	RM/Q	SF/Q	(L/Q)	WIND AXES (D/Q)
50.00	-10.0	.0	-65.8	113.86	-1114.9	42.4	-49.7	4.5	-45.1	123.56
50.00	-6.0	.0	-47.3	108.62	-923.6	56.9	-49.5	3.5	-35.7	112.97
50.00	-2.0	.0	-29.0	103.47	-692.7	63.2	-49.7	2.9	-25.3	104.42
50.00	.0	.0	-18.6	101.68	-571.0	56.9	-51.9	3.3	-18.6	101.68
50.00	2.0	.0	-4.9	100.92	-468.8	46.6	-45.8	4.0	-8.4	100.68
50.00	4.0	.0	10.0	102.82	-419.1	38.6	-33.4	3.2	2.8	103.27
50.00	6.0	.0	25.3	105.64	-362.0	30.8	-28.0	2.9	14.1	107.70
50.00	10.0	.0	50.8	108.17	-180.8	41.8	-19.6	1.4	31.2	115.34
50.00	12.0	.0	64.7	108.57	-73.4	31.0	-13.9	1.7	40.7	119.64

UNIVERSITY OF MARYLAND
WIND TUNNEL OPERATIONS DEPT.
TEST NO 839

BOEING VERTOL CH47 BOXES

FULL SCALE DATA/Q

W.T. TEST RUN 50

Q PSF	AA		AY		L/Q	D/Q	BODY AXES		RM/Q	SF/Q	WIND AXES	
	DEC	DEC	DEC	DEC			M/Q	YM/Q			(L/Q)	(D/Q)
50.00	-10.0	.0	.0	.0	-60.1	115.30	-1177.1	47.4	-46.6	3.3	-39.2	123.98
50.00	-6.0	.0	.0	.0	-42.2	110.33	-978.1	53.7	-45.8	2.6	-30.5	114.14
50.00	-2.0	.0	.0	.0	-25.0	105.80	-746.1	67.2	-46.9	2.7	-21.2	106.61
50.00	.0	.0	.0	.0	-14.3	103.83	-618.2	58.6	-39.9	1.3	-14.3	103.83
50.00	2.0	.0	.0	.0	-4.0	102.86	-502.9	44.0	-43.2	3.1	-7.6	102.66
50.00	4.0	.0	.0	.0	9.6	104.42	-430.7	38.1	-33.2	3.3	2.3	104.83
50.00	6.0	.0	.0	.0	24.2	106.83	-373.1	32.6	-25.3	2.8	12.9	108.77
50.00	10.0	.0	.0	.0	51.0	110.68	-192.9	26.0	-23.6	2.8	31.0	117.85
50.00	12.0	.0	.0	.0	64.9	111.47	-84.7	10.5	-12.0	1.9	40.3	122.53

UNIVERSITY OF MARYLAND
WIND TUNNEL OPERATIONS DEPT.
TEST NO 839

BOEING VERTOL CH47 BOXES

FULL SCALE DATA/Q

W.T. TEST RUN 51

Q PSF	AA DEC	AY DEC	L/Q	D/Q	M/Q	YH/Q	RM/Q	SF/Q	(L/Q)	(D/Q)
50.00	-10.0	.0	-58.3	120.68	-1194.1	35.8	-45.2	3.8	-36.5	128.97
50.00	-6.0	.0	-40.2	116.47	-985.3	35.9	-41.9	3.1	-27.8	120.03
50.00	-2.0	.0	-22.6	111.31	-747.0	30.5	-47.0	3.5	-18.7	112.03
50.00	.0	.0	-12.7	108.81	-625.5	14.0	-51.0	3.8	-12.7	108.81
50.00	2.0	.0	.2	107.61	-532.1	21.4	-50.8	4.1	-3.6	107.55
50.00	4.0	.0	14.1	109.71	-483.6	31.7	-16.1	-3	6.4	110.43
50.00	6.0	.0	27.5	113.06	-415.7	14.6	13.7	-2.6	15.5	115.32
50.00	10.0	.0	53.4	117.29	-217.7	14.9	20.0	-3.6	32.3	124.79
50.00	12.0	.0	66.7	118.14	-124.2	9.6	22.6	-3.5	40.7	129.43

UNIVERSITY OF MARYLAND
WIND TUNNEL OPERATIONS DEPT.
TEST NO 839

BOEING VERTOL CH47 BOXES

FULL SCALE DATA/Q

W.T. TEST RUN 32

Q PSF	AA DEG	AY DEG	L/Q	D/Q	BODY AXES M/Q	YM/Q	RM/Q	SF/Q	(L/Q)	WIND AXES (D/Q)
50.00	-10.0	.0	-58.3	120.60	-1130.0	36.3	-45.3	3.7	-36.5	128.90
50.00	-10.0	-2.0	-58.3	120.76	-1155.4	11.8	77.4	-37.9	-36.5	130.30
50.00	-10.0	-4.1	-54.7	122.26	-1239.0	16.5	151.7	-74.8	-32.6	134.91
50.00	-10.0	-6.0	-53.3	124.53	-1300.9	7.3	216.0	-109.9	-30.8	142.66
50.00	-10.0	-10.0	-53.7	125.98	-1399.3	-21.0	382.4	-182.3	-31.0	163.02
50.00	-10.0	-15.0	-50.0	123.64	-1535.1	-197.1	609.1	-283.8	-27.8	199.45
50.00	-10.0	-20.0	-35.8	128.49	-1766.1	-157.4	620.3	-350.2	-12.9	244.51
50.00	-10.0	-30.0	23.7	79.20	-1801.8	-556.0	1078.8	-563.8	37.1	345.86
50.00	-10.0	.0	-58.7	121.40	-1143.3	36.2	-45.1	6.1	-36.7	129.75
50.00	-10.0	2.0	-58.0	121.84	-1179.7	63.1	-165.4	43.1	-36.0	131.48
50.00	-10.0	4.0	-57.7	124.35	-1218.2	73.1	-244.5	77.8	-35.2	137.57
50.00	-10.0	6.0	-58.6	126.52	-1239.6	58.0	-288.4	111.7	-35.7	145.70
50.00	-10.0	10.0	-58.0	127.18	-1324.2	46.8	-429.3	184.5	-35.1	165.31
50.00	-10.0	15.0	-52.3	123.96	-1397.4	247.8	-1013.0	276.3	-30.0	198.20
50.00	-10.0	20.0	-36.1	117.71	-1409.4	421.7	-1747.0	363.6	-15.1	239.18
50.00	-10.0	30.0	23.5	83.53	-1359.9	265.0	-3305.8	518.5	37.6	326.96

UNIVERSITY OF MARYLAND
WIND TUNNEL OPERATIONS DEPT.
TEST NO 839

BOEING VERTOL CH47 BOXES

FULL SCALE DATA/Q

W.T. TEST RUN 53

Q PSF	AA DEC	AY DEC	L/Q	D/Q	BODY AXES		RM/Q	SF/Q	WIND AXES	
					M/Q	YM/Q			(L/Q)	(D/Q)
50.00	-20.0	.0	-146.5	116.67	-2197.4	131.3	-43.9	-22.5	-97.8	159.74
50.00	-15.0	.0	-105.7	115.11	-1075.1	61.0	-34.4	-16.5	-72.3	138.55
50.00	-12.0	.0	-85.6	111.95	-1689.8	30.3	-35.8	-12.5	-60.4	127.30
50.00	-10.0	.0	-72.6	109.72	-1582.2	26.5	-45.0	-11.0	-52.5	120.67
50.00	-8.0	.0	-61.3	106.90	-1445.2	25.8	-49.9	-9.5	-45.8	114.39
50.00	-6.0	.0	-50.6	104.22	-1316.3	23.7	-48.1	-9.5	-39.4	108.94
50.00	-4.0	.0	-40.0	102.09	-1191.3	17.0	-49.3	-9.2	-32.8	104.63
50.00	-2.0	.0	-28.0	100.46	-1065.4	3.3	-44.4	-9.9	-24.4	101.30
50.00	.0	.0	-14.5	100.86	-962.4	4.4	-43.5	-10.2	-14.5	100.86
50.00	2.0	.0	-2.4	102.46	-875.3	-9.9	-46.2	-11.1	-6.0	102.31
50.00	4.0	.0	10.9	104.45	-777.4	-34.8	-38.5	-10.5	3.6	104.96
50.00	6.0	.0	22.8	105.50	-670.7	-57.1	-26.1	-8.4	11.6	107.30
50.00	8.0	.0	36.2	106.58	-587.7	-62.6	-22.2	-9.2	21.0	110.58
50.00	10.0	.0	49.0	107.50	-486.2	-47.3	-19.7	-11.3	29.6	114.37
50.00	12.0	.0	63.1	107.81	-391.5	-44.4	-16.2	-11.6	39.3	118.57
50.00	15.0	.0	83.1	105.96	-184.6	-57.6	-14.1	-12.0	52.9	123.87
50.00	20.0	.0	117.5	102.02	178.1	-58.4	-28.9	-10.1	75.5	136.05

UNIVERSITY OF MARYLAND
WIND TUNNEL OPERATIONS DEPT.
TEST NO 839

BOEING VERTOL CH47 BOXES

FULL SCALE DATA/Q

W.T. TEST RUN 54

Q PSF	AA DEC	AY DEC	L/Q	D/Q	BODY AXES		RM/Q	SF/Q	WIND AXES	
					M/Q	YN/Q			(L/Q)	(D/Q)
50.00	-10.0	.0	-74.2	108.83	-1532.7	7.3	17.0	-3.2	-54.1	120.05
50.00	-10.0	2.0	-72.4	112.07	-1607.9	66.5	-6.3	13.4	-51.8	123.33
50.00	-10.0	4.0	-71.2	116.35	-1697.5	95.0	-19.4	34.4	-49.9	129.04
50.00	-10.0	6.0	-71.3	119.59	-1773.0	105.9	-40.5	57.8	-49.4	135.48
50.00	-10.0	8.0	-71.0	123.05	-1872.5	118.1	-71.2	82.4	-48.5	143.67
50.00	-10.0	10.0	-69.3	126.27	-1960.4	157.1	-122.8	108.1	-46.3	153.09
50.00	-10.0	15.0	-71.3	129.95	-2097.9	378.0	-308.0	167.2	-47.6	178.04
50.00	-10.0	20.0	-64.2	129.73	-2166.5	461.1	-598.5	236.9	-40.7	211.55
50.00	-10.0	30.0	-74.7	114.11	-2116.2	566.3	-1694.9	354.8	-53.8	285.95
50.00	-10.0	.0	-74.6	109.15	-1524.8	13.4	8.6	-3.3	-54.5	120.45
50.00	-10.0	-2.0	-73.1	111.83	-1581.3	-10.5	-17.9	-17.9	-52.6	123.38
50.00	-10.0	-4.0	-70.8	116.30	-1682.3	-16.1	2.5	-39.5	-49.5	129.28
50.00	-10.0	-6.0	-69.9	120.24	-1792.9	-32.3	32.5	-62.1	-48.0	136.33
50.00	-10.0	-8.0	-68.5	123.38	-1902.8	-67.1	61.5	-84.5	-46.1	143.87
50.00	-10.0	-10.0	-68.1	126.74	-1999.2	-111.1	114.6	-108.2	-45.1	153.34
50.00	-10.0	-15.0	-68.8	131.22	-2156.8	-296.2	303.6	-171.1	-44.9	180.65
50.00	-10.0	-20.0	-66.4	130.98	-2249.7	-363.7	477.7	-242.0	-42.6	214.80
50.00	-10.0	-30.0	-83.7	117.79	-2269.3	-584.1	849.9	-367.1	-62.0	296.59
30.00	-10.0	-60.0	-307.7	48.37	-2098.7	-1354.2	2704.6	-642.6	-294.6	607.00
30.00	-10.0	-90.0	-342.4	-11.57	90.7	121.7	5575.9	-527.2	-339.2	527.19

UNIVERSITY OF MARYLAND
WIND TUNNEL OPERATIONS DEPT.
TEST NO 839

BOEING VERTOL CH47 BOXES

FULL SCALE DATA/Q

W.T. TEST RUN 55

Q PSF	AA DEC	AY DEC	L/Q	D/Q	BODY AXES M/Q	YM/Q	RM/Q	SF/Q	(L/Q)	WIND AXES (D/Q)
50.00	-20.0	.0	-144.9	100.86	-2410.1	39.4	-22.3	-3.6	-101.6	144.32
50.00	-15.0	.0	-101.2	100.91	-2054.5	38.5	-7.6	-3.6	-71.7	123.67
50.00	-12.0	.0	-79.9	98.24	-1833.1	38.2	-8.6	-1.3	-57.7	112.70
50.00	-10.0	.0	-66.6	95.55	-1673.4	42.3	-7.9	-.9	-49.0	105.66
50.00	-8.0	.0	-53.8	92.07	-1488.5	50.0	-6.8	-.4	-40.4	98.66
50.00	-6.0	.0	-43.1	88.82	-1306.1	59.2	-9.1	.1	-33.5	92.84
50.00	-4.0	.0	-32.3	86.34	-1113.3	64.5	-10.2	.5	-26.2	88.38
50.00	-2.0	.0	-22.5	84.59	-945.9	73.8	-11.8	.6	-19.6	85.32
50.00	.0	.0	-12.8	83.35	-763.3	71.2	-13.1	.1	-12.8	83.35
50.00	2.0	.0	-3.2	83.27	-586.6	74.7	-17.2	-.1	-6.1	83.11
50.00	4.0	.0	5.3	84.43	-430.7	65.2	-15.6	.6	-.6	84.60
50.00	6.0	.0	15.3	86.47	-294.9	63.3	-16.3	1.3	6.1	87.59
50.00	8.0	.0	26.5	89.35	-194.0	57.4	-14.8	1.2	13.8	92.17
50.00	10.0	.0	37.9	92.33	-98.8	55.9	-16.4	1.2	21.2	97.50
50.00	12.0	.0	50.5	94.19	-13.8	52.1	-18.3	1.7	29.8	102.63
50.00	15.0	.0	68.2	94.71	154.7	36.8	-17.7	-2.0	41.3	109.13
50.00	20.0	.0	100.4	90.91	485.3	58.9	-22.0	-1.5	63.2	119.76

UNIVERSITY OF MARYLAND
WIND TUNNEL OPERATIONS DEPT.
TEST NO 839

BOEING VERTOL CH47 BOXES

FULL SCALE DATA/Q

W. T. TEST RUN 56

Q PSF	AA DEC	AY DEC	L/Q	D/Q	BODY AXES		RM/Q	SF/Q	WIND AXES	
					M/Q	YM/Q			(L/Q)	(D/Q)
50.00	-10.0	.0	-66.9	95.38	-1669.5	43.6	-6.5	.8	-49.3	105.54
50.00	-10.0	-6.0	-65.5	98.69	-1770.6	-115.3	61.5	-58.9	-47.4	114.12
50.00	-10.0	-10.0	-64.2	101.04	-1098.7	-231.2	114.8	-102.7	-45.7	126.81
50.00	-10.0	-15.0	-67.4	100.60	-1962.0	-394.7	242.8	-159.4	-48.9	148.25
50.00	-10.0	-20.0	-68.3	98.29	-1974.9	-459.6	395.5	-222.7	-50.2	178.28
50.00	-10.0	-30.0	-89.9	82.05	-1914.1	-589.2	762.9	-339.7	-74.2	253.34
50.00	-10.0	.0	-67.2	95.72	-1671.3	47.5	-1.1	.1	-49.5	105.93
50.00	-10.0	6.0	-67.3	99.92	-1781.7	182.4	-73.5	61.0	-48.9	115.85
50.00	-10.0	10.0	-67.1	101.42	-1866.9	272.9	-128.3	107.3	-48.5	128.47
50.00	-10.0	15.0	-71.3	100.72	-1914.4	470.6	-253.6	163.6	-52.7	150.11
50.00	-10.0	20.0	-67.6	97.15	-1937.7	524.3	-395.4	226.0	-49.7	178.21

UNIVERSITY OF MARYLAND
WIND TUNNEL OPERATIONS DEPT.
TEST NO 639

BOEING VERTOL CR47 BOXES

FULL SCALE DATA/Q

W.T. TEST RUN 57

Q PSF	AA		AY		L/Q	D/Q	BODY AXES		RM/Q	SF/Q	WIND AXES	
	DEC	DEC	DEC	DEC			M/Q	YN/Q			(L/Q)	(D/Q)
50.00	-20.0	.0	.0	.0	-141.5	29.40	-1428.9	15.5	2.8	-3.5	-122.9	76.01
50.00	-15.0	.0	.0	.0	-98.5	32.83	-1120.8	37.4	.4	-3.8	-86.7	57.20
50.00	-12.0	.0	.0	.0	-78.5	34.28	-965.4	40.2	-1.5	-2.2	-69.6	49.84
50.00	-10.0	.0	.0	.0	-64.4	35.17	-858.3	45.7	-1.4	-1.3	-57.3	45.82
50.00	-8.0	.0	.0	.0	-52.1	35.92	-745.8	50.4	-3.2	-.9	-46.6	42.82
50.00	-6.0	.0	.0	.0	-41.5	36.51	-616.0	59.6	-4.5	-.4	-37.5	40.65
50.00	-4.0	.0	.0	.0	-31.2	36.92	-462.0	66.0	-4.6	.0	-28.5	39.00
50.00	-2.0	.0	.0	.0	-22.2	37.23	-316.8	70.5	-7.6	.1	-20.9	37.98
50.00	.0	.0	.0	.0	-13.6	37.44	-167.5	75.3	-12.1	.1	-13.6	37.44
50.00	2.0	.0	.0	.0	-4.7	37.42	8.0	83.4	-12.9	-1.0	-6.0	37.24
50.00	4.0	.0	.0	.0	3.2	37.20	171.5	72.1	-11.7	.3	.6	37.34
50.00	6.0	.0	.0	.0	11.5	36.92	345.0	69.9	-11.4	.5	7.6	37.91
50.00	8.0	.0	.0	.0	20.6	36.40	501.0	63.4	-13.3	1.3	15.4	38.91
50.00	10.0	.0	.0	.0	30.0	36.20	645.5	62.7	-16.3	1.3	23.3	40.87
50.00	12.0	.0	.0	.0	41.3	35.57	809.1	57.3	-15.8	1.0	33.0	43.38
50.00	15.0	.0	.0	.0	58.1	33.32	984.5	19.3	-9.5	-1.2	47.5	47.22
50.00	20.0	.0	.0	.0	87.0	29.84	1360.3	35.2	-10.3	-.9	71.6	57.79

UNIVERSITY OF MARYLAND
WIND TUNNEL OPERATIONS DEPT.
TEST NO 839

BOEING VERTOL CH47 BOXES

FULL SCALE DATA/Q

W. T. TEST RUN 58

Q PSF	AA DEG	AY DEG	L/Q	D/Q	H/Q	YH/Q	RM/Q	SF/Q	(L/Q)	WIND AXES (D/Q)
50.00	-10.0	.0	-64.8	35.33	-906.6	46.1	-2	-1.2	-57.7	46.05
50.00	-10.0	2.0	-63.6	35.55	-937.7	131.5	-5.7	14.0	-56.4	46.52
50.00	-10.0	4.0	-62.8	35.42	-949.2	170.3	24.4	31.7	-55.7	47.88
50.00	-10.0	6.0	-63.9	34.56	-952.2	193.2	49.4	50.3	-57.0	50.15
50.00	-10.0	8.0	-63.2	33.29	-965.9	216.0	75.8	70.6	-56.4	53.16
50.00	-10.0	10.0	-63.7	31.91	-974.3	258.1	93.3	90.3	-57.2	57.52
50.00	-10.0	15.0	-67.4	27.48	-981.1	395.1	126.8	133.1	-61.6	71.88
50.00	-10.0	20.0	-66.5	23.33	-962.1	425.8	149.9	181.7	-61.4	94.59
50.00	-10.0	30.0	-89.0	12.45	-752.6	509.6	-193.3	265.0	-85.5	156.52
50.00	-10.0	.0	-65.6	35.21	-905.8	42.4	-9.9	-1.9	-58.5	46.07
50.00	-10.0	-2.0	-65.3	35.43	-910.6	-61.4	-11.5	-16.6	-58.1	46.77
50.00	-10.0	-4.0	-63.6	35.02	-940.8	-94.1	-37.0	-34.1	-56.6	47.81
50.00	-10.0	-6.0	-62.4	34.49	-953.3	-128.3	-57.9	-51.3	-55.4	49.91
50.00	-10.0	-8.0	-62.0	33.36	-988.2	-161.5	-82.3	-69.6	-55.3	52.89
50.00	-10.0	-10.0	-62.1	32.19	-1012.8	-223.2	-96.5	-86.4	-55.6	56.83
50.00	-10.0	-15.0	-65.9	28.00	-1021.4	-323.4	-133.5	-132.9	-60.0	72.00
50.00	-10.0	-20.0	-69.1	24.15	-1011.0	-352.8	-157.5	-180.3	-63.9	95.28
50.00	-10.0	-30.0	-93.9	10.78	-1000.5	-399.8	-201.7	-272.0	-90.6	159.30
30.00	-10.0	-60.0	-313.8	-15.52	-1642.5	-713.4	560.3	-474.0	-311.7	430.08
30.00	-10.0	-90.0	-349.4	-24.94	4.3	894.0	1248.3	-429.5	-348.4	429.46

UNIVERSITY OF MARYLAND
WIND TUNNEL OPERATIONS DEPT.
TEST NO 839

BOEING VERTOL CH47 BOXES

FULL SCALE DATA/Q

W.T. TEST RUN 59

Q PSF	AA DEC	AY DEC	L/Q	D/Q	BODY AXES M/Q	YM/Q	RM/Q	SF/Q	(L/Q)	WIND AXES (D/Q)
50.00	-10.0	.0	-68.1	115.95	-1136.3	19.2	-55.9	7.8	-47.0	126.02
50.00	-6.0	.0	-49.5	111.07	-943.7	33.3	-54.8	6.3	-37.6	115.64
50.00	-2.0	.0	-28.8	106.25	-720.9	36.3	-53.2	6.0	-25.1	107.19
50.00	.0	.0	-16.6	104.15	-598.1	36.4	-52.6	6.0	-16.6	104.15
50.00	2.0	.0	-3.8	103.39	-498.5	36.1	-42.8	4.9	-7.4	103.19
50.00	4.0	.0	10.4	105.06	-438.0	35.7	-40.8	4.6	3.1	105.54
50.00	6.0	.0	25.7	107.47	-379.2	29.0	-35.9	4.0	14.3	109.57
50.00	8.0	.0	39.6	109.01	-294.9	33.8	-37.2	4.0	24.1	113.46
50.00	10.0	.0	52.3	109.53	-199.1	35.6	-40.5	4.4	32.5	116.95
50.00	12.0	.0	66.0	109.83	-92.0	17.0	-33.0	2.8	41.7	121.15
50.00	15.0	.0	86.7	111.10	76.3	-7.0	-20.0	.9	55.0	129.77
50.00	20.0	.0	121.0	111.77	405.1	7.4	-25.1	1.2	75.5	146.43
50.00	-20.0	.0	-110.8	127.80	-1709.1	15.4	-78.4	10.5	-60.4	157.99
50.00	-15.0	.0	-76.2	118.34	-1255.1	9.7	-62.0	9.5	-54.5	141.80
50.00	-12.0	.0	-58.3	116.22	-1148.8	18.6	-62.6	8.6	-49.9	131.60
50.00	-8.0	.0	-49.1	113.48	-1039.3	26.3	-57.9	7.7	-46.5	126.21
50.00	-6.0	.0	-39.4	110.93	-940.8	30.7	-58.0	6.5	-42.0	120.50
50.00	-4.0	.0	-28.8	108.44	-828.5	36.4	-59.1	6.7	-37.2	115.46
50.00	-2.0	.0	-28.8	106.26	-721.0	37.4	-56.7	6.8	-31.7	110.92
50.00	.0	.0						5.8	-25.1	107.20

UNIVERSITY OF MARYLAND
WIND TUNNEL OPERATIONS DEPT.
TEST NO 839

BOEING VERTOL CH47 BOXES

FULL SCALE DATA/Q

W.T. TEST RUN 60

Q PSF	AA DEC	AY DEC	L/Q	D/Q	BODY AXES		RM/Q	SF/Q	WIND AXES	
					M/Q	YM/Q			(L/Q)	(D/Q)
50.00	-10.0	.0	-68.3	116.21	-1145.0	19.9	-53.7	7.8	-47.1	126.31
50.00	-10.0	2.0	-68.3	118.19	-1199.2	35.3	-177.0	46.1	-46.7	129.78
50.00	-10.0	4.0	-68.6	121.72	-1277.5	-2.2	-247.9	81.5	-46.5	137.15
50.00	-10.0	6.0	-68.5	124.81	-1304.0	-49.1	-322.5	119.3	-45.8	146.55
50.00	-10.0	8.0	-66.1	124.39	-1357.3	-45.3	-403.0	157.4	-43.5	154.59
50.00	-10.0	10.0	-62.3	123.94	-1416.7	-16.6	-479.6	197.1	-39.8	165.07
50.00	-10.0	15.0	-51.4	120.32	-1482.9	188.4	-980.6	283.0	-29.7	196.31
50.00	-10.0	20.0	-31.2	116.60	-1366.1	404.9	-1548.8	356.6	-19.5	234.97
50.00	-10.0	30.0	25.3	88.25	-1334.8	251.6	-3078.7	518.7	40.2	330.79
50.00	-10.0	.0	-68.5	116.66	-1146.9	28.7	-40.4	1.4	-47.2	126.78
50.00	-10.0	-2.0	-68.4	117.28	-1175.5	19.2	90.1	-40.3	-47.0	128.70
50.00	-10.0	-4.0	-66.4	119.44	-1273.1	51.7	164.5	-75.2	-44.7	134.09
50.00	-10.0	-6.0	-67.4	122.08	-1342.7	121.5	235.0	-112.5	-45.1	143.76
50.00	-10.0	-8.0	-63.2	122.63	-1421.2	114.5	329.4	-151.3	-41.0	151.51
50.00	-10.0	-10.0	-60.8	121.76	-1488.3	61.1	420.0	-190.5	-38.8	161.57
50.00	-10.0	-15.0	-50.4	117.09	-1633.0	-99.6	604.1	-284.1	-29.3	193.36
50.00	-10.0	-20.0	-32.8	112.52	-1653.2	-314.2	742.3	-364.8	-12.8	234.25
50.00	-10.0	-30.0	36.2	36.01	-3271.4	-829.9	1846.6	-521.9	41.9	206.20
30.00	-10.0	-60.0	-64.2	-47.28	-3428.8	-2996.0	6851.2	-664.3	-71.5	557.61
30.00	-10.0	-90.0	7.8	-55.31	-789.0	-715.9	9792.6	-589.9	-1.9	589.93
30.00	-10.0	60.0	-100.6	27.54	-328.9	1937.5	-2736.9	786.2	-94.3	763.17
30.00	-10.0	90.0	-14.0	-28.80	-48.2	-926.6	-2028.7	830.7	-18.8	830.72

UNIVERSITY OF MARYLAND
WIND TUNNEL OPERATIONS DEPT.
TEST NO 839

BOEING VERTOL CH47 BOXES

FULL SCALE DATA/Q

W.T. TEST RUN 61

Q PSF	AA DEC	AY DEC	L/Q	D/Q	BODY AXES		RM/Q	SF/Q	WIND AXES	
					M/Q	YH/Q			(L/Q)	(D/Q)
50.00	-10.0	.0	-68.1	116.70	-1141.0	21.2	-36.5	3.7	-46.8	126.76
50.00	-6.0	.0	-49.2	110.87	-930.8	26.0	-38.0	2.0	-37.4	115.40
50.00	-2.0	.0	-28.5	105.79	-721.9	38.4	-33.9	1.8	-24.8	106.73
50.00	.0	.0	-16.6	103.65	-601.1	35.5	-29.8	1.2	-16.6	103.65
50.00	2.0	.0	-4.1	102.66	-489.8	25.9	-18.8	-.3	-7.7	102.45
50.00	4.0	.0	10.5	104.62	-426.6	27.1	-17.1	.6	3.2	105.10
50.00	6.0	.0	25.5	106.90	-368.0	20.3	-12.9	.3	14.2	108.98
50.00	10.0	.0	51.3	108.65	-178.4	22.7	-12.9	-.3	31.6	115.90
50.00	12.0	.0	64.1	108.18	-72.7	10.5	-10.1	-1.0	40.2	119.14
50.00	-12.0	.0	-77.3	119.26	-1246.5	17.3	-37.9	4.4	-50.8	132.72
50.00	-20.0	.0	-109.9	127.84	-1711.4	29.7	-54.8	4.2	-59.5	157.71

UNIVERSITY OF MARYLAND
WIND TUNNEL OPERATIONS DEPT.
TEST NO 839

BOEING VERTOL CH47 BOXES

FULL SCALE DATA/Q

W.T. TEST RUN 62

Q PSF	AA		AY		L/Q	D/Q	BODY AXES		RM/Q	SF/Q	WIND AXES	
	DEC	DEC	DEC	DEC			M/Q	YM/Q			(L/Q)	(D/Q)
50.00	-15.0	.0	.0	.0	-89.6	122.62	-1405.2	18.2	-43.2	5.0	-54.8	141.62
50.00	-12.0	.0	.0	.0	-76.7	118.96	-1248.5	21.4	-40.9	3.5	-50.3	132.31
50.00	-10.0	.0	.0	.0	-68.5	116.53	-1140.8	29.7	-40.6	3.3	-47.2	126.66
50.00	-6.0	.0	.0	.0	-50.8	111.18	-939.4	29.6	-37.5	2.2	-38.9	116.88
50.00	-2.0	.0	.0	.0	-30.0	106.03	-721.5	40.0	-35.0	1.7	-26.2	107.01
50.00	.0	.0	.0	.0	-18.3	103.60	-596.4	37.5	-31.3	.9	-18.3	103.60
50.00	2.0	.0	.0	.0	-6.3	102.53	-478.1	33.5	-25.6	.6	-9.9	102.25
50.00	4.0	.0	.0	.0	7.7	103.02	-398.2	28.3	-22.6	1.0	.5	103.31
50.00	6.0	.0	.0	.0	22.5	105.27	-346.6	25.8	-20.1	1.0	11.4	107.05
50.00	10.0	.0	.0	.0	48.6	107.44	-152.1	22.0	-19.6	.4	29.2	114.24
50.00	12.0	.0	.0	.0	61.4	107.05	-47.5	17.1	-15.5	-1.1	37.8	117.47
50.00	15.0	.0	.0	.0	81.4	107.56	137.5	-18.8	1.7	-3.5	50.8	124.97
50.00	-4.0	.0	.0	.0	-40.7	108.77	-844.9	34.3	-37.1	1.9	-33.0	111.35
50.00	-8.0	.0	.0	.0	-59.8	113.92	-1036.3	29.4	-39.3	2.9	-43.4	121.14

UNIVERSITY OF MARYLAND
WIND TUNNEL OPERATIONS DEPT.
TEST NO 839

BOEING VERTOL CH47 BOXES

FULL SCALE DATA/Q

W.T. TEST RUN 63

Q PSF	AA DEC	AY DEC	L/Q	D/Q	M/Q	YM/Q	RM/Q	SF/Q	(L/Q)	WIND AXES (D/Q)
50.00	-10.0	.0	-68.8	116.76	-1075.3	21.0	-39.2	3.1	-47.5	126.94
50.00	-10.0	-6.0	-69.5	122.14	-1249.4	114.1	242.6	-112.5	-47.2	143.39
50.00	-10.0	-10.0	-62.3	121.26	-1405.9	52.7	418.3	-190.6	-40.3	161.36
50.00	-10.0	-15.0	-51.4	116.95	-1571.1	-113.1	606.7	-287.1	-30.3	194.19
50.00	-10.0	-20.0	-34.9	110.80	-1616.8	-330.8	756.7	-367.9	-15.1	234.04
50.00	-10.0	-30.0	31.2	41.94	-2945.8	-871.4	1863.9	-517.5	38.0	289.79
50.00	-10.0	-8.0	-67.2	121.80	-1324.6	90.1	347.4	-144.8	-45.1	150.49
50.00	-10.0	-4.0	-68.6	118.70	-1168.3	16.3	175.5	-69.2	-47.0	133.32
50.00	-10.0	-2.0	-69.6	117.33	-1100.4	-16.2	87.6	-29.9	-48.1	128.59
50.00	-10.0	.0	-69.3	117.43	-1083.2	17.2	-44.9	10.0	-47.9	127.68
50.00	-10.0	2.0	-71.2	119.49	-1122.6	13.0	-165.2	47.4	-49.4	131.62
50.00	-10.0	4.0	-72.2	121.97	-1188.8	-20.1	-232.8	82.0	-49.9	138.05
50.00	-10.0	6.0	-71.9	124.56	-1222.6	-59.7	-312.2	119.2	-49.2	146.87
50.00	-10.0	8.0	-68.9	124.10	-1280.8	-60.6	-385.3	157.9	-46.3	154.85
50.00	-10.0	10.0	-64.2	123.09	-1338.1	-40.8	-449.5	197.8	-41.9	164.70
50.00	-10.0	15.0	-52.2	119.71	-1425.8	176.3	-946.0	285.0	-30.6	196.38
50.00	-10.0	20.0	-34.4	114.48	-1338.4	406.6	-1530.7	358.5	-14.0	234.16
50.00	-10.0	30.0	19.5	87.05	-1212.9	344.0	-2949.5	514.0	34.3	328.29

UNIVERSITY OF MARYLAND
WIND TUNNEL OPERATIONS DEPT.
TEST NO 839

BOEING VERTOL CH47 BOXES

FULL SCALE DATA/Q

V.T. TEST RUN 64

Q PSF	AA DEC	AY DEC	L/Q	D/Q	BODY AXES N/Q	YN/Q	RM/Q	SF/Q	(L/Q)	WIND AXES (D/Q)
50.00	-10.0	.0	-64.9	118.75	-1186.4	26.4	-30.5	1.3	-43.3	128.20
50.00	-6.0	.0	-46.2	112.88	-974.9	32.7	-30.5	.9	-34.2	117.09
50.00	-2.0	.0	-26.2	107.79	-756.9	38.2	-32.4	.8	-22.4	108.63
50.00	.0	.0	-10.7	105.10	-622.9	30.2	-26.4	.1	-15.7	105.10
50.00	2.0	.0	-4.1	103.88	-495.4	29.1	-17.9	-.3	-7.7	103.68
50.00	4.0	.0	9.2	104.56	-413.5	31.4	-12.7	-.1	1.9	104.95
50.00	6.0	.0	24.5	107.12	-361.7	19.1	-14.9	.3	13.2	109.09
50.00	10.0	.0	51.4	109.92	-183.0	38.6	-8.1	-1.4	31.5	117.17
50.00	12.0	.0	63.9	109.04	-69.3	23.4	-3.5	-2.3	39.8	119.94
50.00	15.0	.0	84.2	109.86	135.0	-11.6	18.1	-4.9	52.9	127.90

UNIVERSITY OF MARYLAND
WIND TUNNEL OPERATIONS DEPT.
TEST NO 839

BOEING VERTOL CH47 BOXES

FULL SCALE DATA/Q

V.T. TEST RUN 65

Q PSF	AA DEC	AY DEC	L/Q	D/Q	M/Q	Y/M/Q	RM/Q	SF/Q	(L/Q)	WIND AXES (D/Q)
50.00	-20.0	.0	-143.4	28.81	-1402.4	10.7	.9	-4.2	-124.9	76.12
50.00	-15.0	.0	-99.6	32.63	-1119.2	27.7	-1.3	-4.2	-87.8	57.31
50.00	-12.0	.0	-70.3	34.05	-960.0	27.2	-4.5	-2.4	-69.5	49.59
50.00	-10.0	.0	-66.2	35.07	-861.2	28.2	-2.9	-1.8	-59.1	46.04
50.00	-8.0	.0	-53.9	35.79	-750.2	38.4	-6.7	-1.7	-48.4	42.94
50.00	-6.0	.0	-42.7	36.34	-610.3	44.5	-9.1	-1.2	-38.7	40.60
50.00	-4.0	.0	-32.6	36.82	-466.8	51.4	-9.2	-.4	-30.0	39.00
50.00	-2.0	.0	-23.3	37.10	-310.8	61.9	-12.2	-.5	-22.0	37.89
50.00	.0	.0	-14.5	37.21	-173.9	61.4	-17.2	-.5	-14.5	37.21
50.00	2.0	.0	-5.7	37.09	5.1	61.1	-19.6	-1.2	-7.0	36.86
50.00	4.0	.0	2.1	37.01	182.7	51.2	-15.9	.0	-.5	37.07
50.00	6.0	.0	10.0	36.69	354.8	50.8	-16.6	.5	6.1	37.54
50.00	8.0	.0	18.3	36.16	518.4	43.6	-17.1	.6	13.1	38.35
50.00	10.0	.0	27.0	35.93	686.2	40.7	-17.0	.3	20.4	40.08
50.00	12.0	.0	36.7	35.47	851.3	39.6	-20.3	.3	28.5	42.33
50.00	15.0	.0	50.9	33.78	1086.4	43.7	-20.4	.3	40.4	45.81
50.00	20.0	.0	79.6	30.20	1444.1	50.7	-21.8	-3.1	64.5	55.62

UNIVERSITY OF MARYLAND
WIND TUNNEL OPERATIONS DEPT.
TEST NO 839

BOEING VERTOL CH47 BOXES

FULL SCALE DATA/Q

W.T. TEST RUN 66

Q PSF	AA DEC	AY DEC	L/Q	D/Q	BODY AXES			RM/Q	SF/Q	WIND AXES	
					M/Q	YM/Q	(L/Q)			(D/Q)	
50.00	-10.0	.0	-66.1	35.06	-861.4	31.4	-3.2	-1.5	-59.0	46.00	
50.00	-10.0	2.0	-64.6	35.45	-887.1	123.0	-7.7	13.7	-57.5	46.58	
50.00	-10.0	4.0	-64.1	35.38	-907.7	164.3	13.6	31.1	-57.0	48.03	
50.00	-10.0	6.0	-64.1	34.60	-909.7	180.6	44.4	50.3	-57.1	50.21	
50.00	-10.0	8.0	-64.6	33.42	-925.0	201.1	74.6	69.5	-57.9	53.39	
50.00	-10.0	10.0	-65.2	32.06	-925.7	236.8	91.9	88.1	-58.6	57.55	
50.00	-10.0	15.0	-68.0	27.51	-939.0	372.0	136.2	132.2	-62.2	71.80	
50.00	-10.0	20.0	-67.4	22.67	-928.4	422.5	154.1	179.9	-62.5	93.52	
50.00	-10.0	30.0	-91.1	11.93	-702.6	532.0	-189.7	262.1	-87.7	154.94	
50.00	-10.0	.0	-66.2	35.14	-862.7	24.4	-15.1	-2.9	-59.1	46.11	
50.00	-10.0	-2.0	-66.2	35.51	-875.4	-64.2	-16.9	-17.0	-59.0	47.03	
50.00	-10.0	-4.0	-64.6	35.27	-899.7	-100.6	-42.6	-34.4	-57.5	48.23	
50.00	-10.0	-6.0	-63.5	34.94	-918.8	-135.0	-70.5	-52.4	-56.4	50.66	
50.00	-10.0	-8.0	-63.3	34.03	-943.2	-169.1	-90.5	-70.5	-56.4	53.89	
50.00	-10.0	-10.0	-64.3	32.73	-949.1	-231.1	-107.7	-87.7	-57.6	57.96	
50.00	-10.0	-15.0	-65.7	28.26	-980.4	-344.2	-140.0	-132.4	-59.8	72.17	
50.00	-10.0	-20.0	-70.3	24.05	-968.2	-373.0	-171.1	-181.7	-65.0	95.86	
50.00	-10.0	-30.0	-95.2	12.08	-944.1	-434.5	-228.9	-272.7	-91.6	160.96	
30.00	-10.0	-60.0	-316.2	-12.87	-1486.0	-664.7	357.4	-484.8	-313.6	440.94	
30.00	-10.0	-90.0	-360.6	-24.97	12.4	902.8	1024.5	-435.0	-359.5	434.97	

UNIVERSITY OF MARYLAND
WIND TUNNEL OPERATIONS DEPT.
TEST NO 839

BOEING VERTOL CH47 BOXES

FULL SCALE DATA/Q

W.T. TEST RUN 67

Q PSF	AA DEC	AY DEC	L/Q	D/Q	M/Q	YM/Q	RM/Q	SF/Q	(L/Q)	WIND AXES (D/Q)
50.00	-20.0	.0	-143.9	24.59	-1369.4	4.3	1.8	-4.4	-126.8	72.33
50.00	-15.0	.0	-101.0	27.95	-1059.9	25.8	-1.3	-3.2	-90.4	53.15
50.00	-12.0	.0	-80.6	29.57	-899.0	30.0	-2.9	-2.4	-72.7	45.68
50.00	-10.0	.0	-67.5	30.32	-801.3	36.7	-3.0	-1.3	-61.2	41.57
50.00	-8.0	.0	-54.5	31.01	-684.4	42.8	-4.4	-1.0	-49.7	38.30
50.00	-6.0	.0	-43.0	31.65	-550.3	52.0	-6.8	-1.8	-39.4	35.97
50.00	-4.0	.0	-33.0	32.18	-414.9	60.1	-8.5	-1.3	-30.7	34.41
50.00	-2.0	.0	-23.5	32.48	-263.0	69.1	-10.5	.0	-22.4	33.28
50.00	.0	.0	-14.2	32.45	-106.7	72.2	-12.3	.0	-14.2	32.45
50.00	2.0	.0	-6.4	32.37	72.2	81.0	-13.4	.4	-6.5	32.17
50.00	4.0	.0	2.4	32.19	234.8	67.1	-10.9	1.0	.1	32.28
50.00	6.0	.0	11.2	31.94	424.7	67.9	-11.7	1.3	7.8	32.93
50.00	8.0	.0	19.0	31.53	561.3	65.1	-12.5	2.2	14.5	33.87
50.00	10.0	.0	29.2	31.49	732.9	57.6	-15.6	2.0	23.3	36.08
50.00	12.0	.0	38.8	31.18	888.8	56.7	-18.7	2.3	31.5	38.57
50.00	15.0	.0	53.3	29.15	1110.1	32.6	-13.0	-1.8	43.9	41.95
50.00	20.0	.0	82.5	26.12	1500.2	52.1	-16.6	.4	68.6	52.76

UNIVERSITY OF MARYLAND
WIND TUNNEL OPERATIONS DEPT.
TEST NO 839

BOEING VERTOL CH47 BOXES

FULL SCALE DATA/Q

W.T. TEST RUN 68

Q PSF	AA DEG	AY DEG	L/Q	D/Q	BODY AXES		RM/Q	SF/Q	WIND AXES	
					M/Q	YM/Q			(L/Q)	(D/Q)
50.00	-10.0	.0	-67.4	30.44	-814.8	44.9	-2.1	-0.8	-61.1	41.68
50.00	-10.0	-2.0	-68.2	30.70	-814.3	-60.6	-10.5	-14.7	-61.8	42.56
50.00	-10.0	-4.0	-66.0	30.10	-840.4	-96.5	-37.1	-31.5	-59.8	43.20
50.00	-10.0	-6.0	-64.8	29.44	-870.9	-131.0	-58.9	-49.3	-58.8	45.18
50.00	-10.0	-8.0	-64.3	28.57	-898.0	-160.1	-91.9	-68.2	-58.4	48.41
50.00	-10.0	-10.0	-64.6	27.28	-915.2	-216.9	-112.3	-84.6	-58.9	52.19
50.00	-10.0	-15.0	-67.0	23.04	-946.9	-321.1	-153.3	-129.3	-62.0	66.60
50.00	-10.0	-20.0	-70.9	18.92	-937.9	-348.7	-186.2	-176.6	-66.6	89.48
30.00	-10.0	-30.0	-95.7	6.79	-918.3	-411.1	-257.7	-268.4	-93.1	154.37
30.00	-10.0	-60.0	-316.8	-17.63	-1595.5	-717.5	512.6	-469.2	-315.1	425.15
30.00	-10.0	-90.0	-367.9	-20.62	890.0	956.4	1202.6	-420.4	-365.9	420.37

UNIVERSITY OF MARYLAND
WIND TUNNEL OPERATIONS DEPT.
TEST NO 839

BOEING VERTOL CH47 BOXES

FULL SCALE DATA/Q

W.T. TEST RUN 69

Q PSF	AA DEG	AY DEG	L/Q	D/Q	M/Q	YM/Q	RM/Q	SF/Q	(L/Q)	WIND AXES (D/Q)
50.00	-10.0	.0	-67.1	32.71	-838.9	43.1	-3.5	-.8	-60.4	43.87
50.00	-6.0	.0	-43.1	33.99	-588.2	59.9	-7.2	-.1	-39.3	36.31
50.00	-2.0	.0	-23.2	34.74	-287.3	77.4	-10.1	1.0	-22.0	35.53
50.00	.0	.0	-14.2	34.69	-134.3	75.3	-14.7	.4	-14.2	34.69
50.00	2.0	.0	-5.8	34.67	39.5	72.8	-15.2	.4	-7.0	34.44
50.00	4.0	.0	2.4	34.50	216.2	65.9	-12.9	1.0	.0	34.59
50.00	6.0	.0	10.2	34.22	385.2	67.2	-12.9	.6	6.5	35.10
50.00	10.0	.0	27.7	33.53	717.8	61.2	-19.0	1.8	21.5	37.84
50.00	12.0	.0	38.3	33.04	894.3	54.7	-20.6	1.4	30.6	40.28

UNIVERSITY OF MARYLAND
WIND TUNNEL OPERATIONS DEPT.
TEST NO 839

BOEING VERTOL CH47 BOXES

FULL SCALE DATA/Q

W. T. TEST RUN 70

Q PSF	AA DEC		AY DEC		L/Q	D/Q	BODY AXES M/Q		YM/Q	RM/Q	SF/Q	WIND AXES (L/Q) (D/Q)	
50.00	-10.0		.0		-66.8	32.63	-847.1	42.1	-5	-60.2	43.74		
50.00	-10.0		-4.0		-65.0	32.51	-871.1	-100.1	-39.0	-58.4	45.45		
50.00	-10.0		-8.0		-64.2	31.08	-917.5	-162.9	-93.1	-68.2	50.84		
50.00	-10.0		-12.0		-66.0	28.53	-947.2	-292.2	-118.2	-102.2	59.94		
50.00	-10.0		-15.0		-67.0	25.42	-967.3	-325.1	-148.2	-131.2	69.38		
50.00	-10.0		-20.0		-70.4	20.56	-961.8	-391.3	-168.5	-177.6	91.25		
50.00	-10.0		-30.0		-97.0	8.99	-918.2	-407.0	-248.0	-268.0	156.25		

APPENDIX C

BREEZE CORPORATION -

HOIST PROPOSAL

PROPOSAL
FOR A
CARGO CONTAINER RESTRAINT HOIST SYSTEM

Prepared for

Boeing Vertol Company
P. O. Box 16858
Philadelphia, Pennsylvania 19142

Submitted By:

BREEZE CORPORATIONS, INC.
700 Liberty Avenue
Union, New Jersey 07083

Prepared by:

Eugene Kim-Eng
Project Engineer

Approved by:

E. Edwards
Manager of Advanced Design

Approved by:

Robert Felber
Engineering Manager

Date: May 7, 1979

TABLE OF CONTENTS

<u>PARAGRAPH</u>	<u>CONTENTS</u>	<u>PAGE</u>
1.0	SCOPE.....	1
1.1	General.....	1
1.2	Intended Use.....	1-2
2.0	DESCRIPTION.....	2
2.1	General.....	2-3
2.2	Electric Motor.....	4
2.3	Safety Load Brake.....	4-5
2.4	Gear Train.....	5
2.5	Cable Drum.....	6
2.6	Hoist Side Frames.....	7
2.7	Cable Anti-Fouling Control.....	7
2.8	Cable Levelwind.....	8
2.9	Limit Switches.....	8
3.0	TECHNICAL DATA - HOIST SYSTEM.....	9
3.1	Definition.....	9
3.2	Hoist Assembly Performance Requirements....	9
4.0	DESCRIPTION OF HOIST ASSEMBLIES.....	9
5.0	ESTIMATED WEIGHT.....	10
6.0	APPLICABLE DOCUMENTS.....	10
6.1	Government Documents.....	10-11
6.2	Non-Government Documents.....	11
	APPENDIX I - Hoist System Information Supplied to Breeze Corps., Inc. by Boeing Vertol	
	APPENDIX II- Bulletin-Breeze Load Lowering Safety Brake	
	APPENDIX III - Weight Analysis	
	APPENDIX IV - Stress Analysis	
	APPENDIX V - Motor & Brake Assembly Outline (BL-3168-1)	

A B S T R A C T

This proposal describes a cargo container restraint system proposed for use on the CH-47D Helicopter. The proposal is the result of verbal discussions between Boeing Vertol Company and Breeze Corporations, Inc. Design and test criteria are established.

PROPOSAL FOR A
CARGO CONTAINER RESTRAINT HOIST SYSTEM

1.0 SCOPE

1.1 General

This proposal is the result of verbal discussions held in early 1978 between Messrs. Richard Campbell of Boeing Vertol and Ralph Walsh of Breeze Corporations concerning the feasibility of snubbing a cargo container against the main landing gear of a CH-47D type helicopter. It describes the technical parameters and engineering responsibilities for the design, development, testing, and manufacturing of a cargo container restraint hoist system in compliance with preliminary information supplied to Mr. Walsh by Mr. Campbell.

1.2 Intended Use

This system is intended for use with the Boeing Vertol CH-47D helicopter in combination with an unspecified cargo container with a working capacity of 25,000 pounds and a projected ultimate static capacity of 100,000 pounds. The system consists of a pair of hoist assemblies mounted to the frame of the cargo container. The hoist assemblies interface mechanically

with the aircraft by means of existing cargo hooks mounted to the aircraft and interface with their control components mounted on board the aircraft by means of electrical umbilical harnesses.

2.0 DESCRIPTION

2.1 General

The cargo container restraint hoist system consists of a pair of hoist assemblies with their drive motors and cables. The usable length of the cables is 22 feet when the hoist is unloaded and 12 feet when the hoist is fully loaded. The cables are terminated at their free ends in loops formed in #C-4 MacWhyte crescent thimbles. The free ends are swaged through eye splice sleeves. The hoist system complies with the interface fittings for attachment to the cargo container as described in drawings supplied by Boeing Vertol (see Appendix I). The electrical interface of the hoist system with the aircraft is accomplished by means of the following connector receptacles: (1) AC power input via MS3102R-18-11P, and (2) Control via MS24265. Each hoist subassembly carries one of each connector receptacle. The receptacles are positioned to facilitate easy removal

of the electrical harnessing. The hoist will require an input power of 115 volts AC, 400 Hz, 3 phase, complying with MIL-STD-704, with 4.48 KVA capacity. A schematic of the hoist drive train is shown in FIG. A.

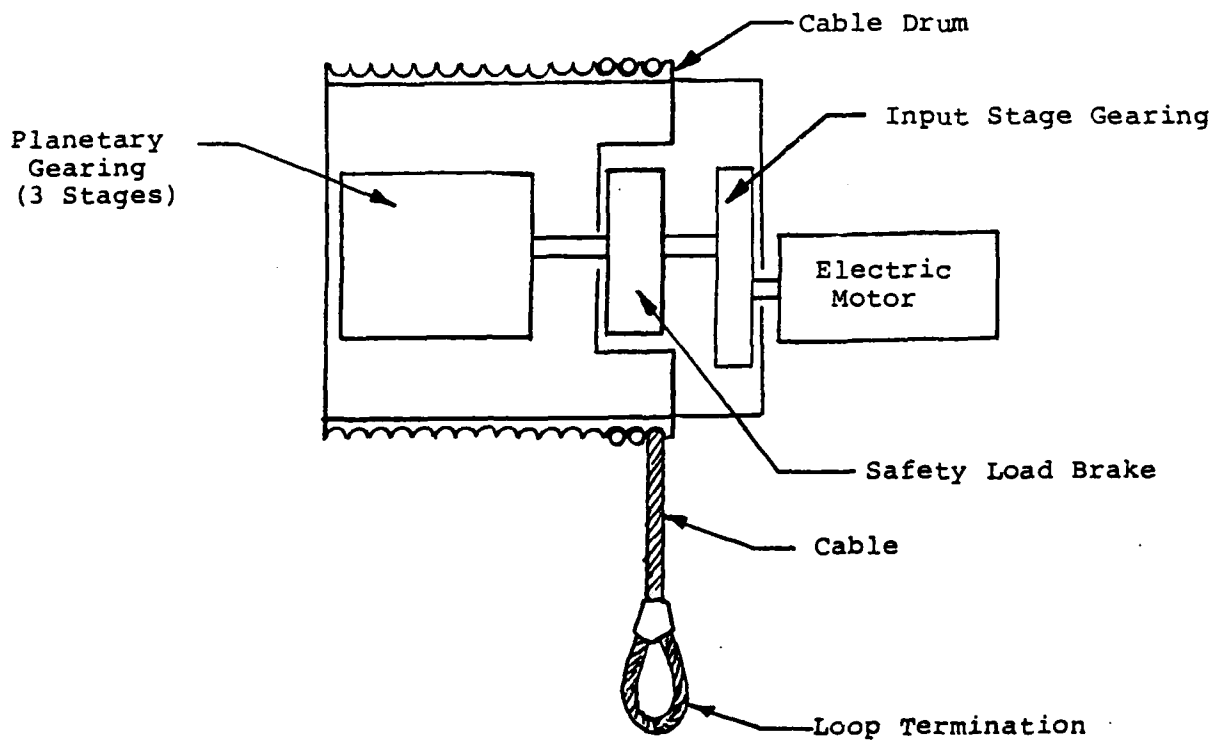

FIG. A

2.2 Electric Motor

Each hoist assembly is driven by an electric motor with integral brake. The motor is a 3 phase alternating current type, powered by 115V at 400 Hz. The motor is totally enclosed and is constructed to meet the requirements of MIL-M-7969. Motor cooling is accomplished by means of radiation fins on the motor case. The motor is similar in configuration to Breeze part number BL-3168-1 (see drawing, Appendix V).

2.3 Safety Load Brake

The safety load brake is a self-energizing mechanically actuated type of proven effectiveness. The safety load brake consists of an overrunning sprag clutch assembly, a multi-disc brake pack, and an anti-friction actuating ramp. The brake functions by permitting the hoist motor and drive train to propel the cable drum in the lifting or hoisting mode by overrunning the sprag clutch assembly. In the load lowering mode, the sprag clutch engages to lock the load carrying multi-disc brake pack to the hoist frame, and the multi-disc brake pack is forced to support the cable load. The load is lowered by energizing the hoist motor which drives through the gear train to release the multi-disc brake pack permitting the load to be lowered. Load lowering is

controlled positively by the action of the hoist motor which opens the multi-disc brake pack and alternately permits the cable load to set or lock the brake by a reverting action of the load. The safety load brake is operated in a reservoir of MIL-L-23699 oil which acts as a coolant and heat transfer medium to dissipate the energy to the cable drum, cable, and other hoist components, which act as heat sinks to absorb and discharge the heat generated by the brake. The fundamentals of the brake's operation are described and illustrated in a Breeze Corps., Inc. Bulletin (see Appendix II).

2.4

Gear Train

The hoist drive gear train consists of three stages of planetary gearing operating in a lubricating packing of MIL-G-21164C grease. The gear train is located at the output of the safety load brake and drives the cable drum through an internal gear, cut into the inner diameter of the drum, which comprises the third planet stage ring gear. The arrangement of the gear train is similar to that of other Breeze hoist drive trains which have efficiencies of approximately 70%. All gears are aircraft quality, heat treated and ground, and are mounted on anti-friction bearings.

2.5

Cable Drum

The hoist cable drum is made of alloy steel. The outer surface of the cable drum provides a continuous helical cable support groove to ensure uniform cable lay-up and accommodates a maximum usable cable length of 22 feet plus 1.5 inactive turns in a single layer. The cable termination at the drum is locked into a cable socket with an easily accessible screw fastening. The inner diameter of the drum provides the lubrication reservoir for the hoist gear train. The planetary drive ring gears are cut integral with the inner diameter of the drum, and ancillary drives to operate the hoist limit switches are directly driven from the drum to assure reliable cable handling. The drum is supported on anti-friction bearings mounted to the hoist side frames, and its design is coordinated with that of the hoist side frames to ensure an unimpeded cable path.

A0-A088 057

BOEING VERTOL CO PHILADELPHIA PA F/0 1/3
DESIGN AND ANALYSIS OF CH-47 EXTERNAL CARGO HANDLING SYSTEM (SN--ETC(U))
OCT 79 T S GARNETT, R F CAMPBELL, D J HODDER DAAJ02-77-C-0069
UNCLASSIFIED D210-11555-1 ML

5 of 5

NO

████

END
DATE
FILMED
9-80
DTIC

2.6 Hoist Side Frames

The hoist side frames are made of high strength aluminum alloy and provide the chassis for the hoist subassembly. The side frames are rigidly linked by tubular members which form an integral part of the hoist structure. Levelwind, cable anti-fouling, and limit switch mechanisms are supported by the side frames and are guarded against intrusion by debris. The side frames provide mechanical interface between motor and drive train through a secondary housing mounted to one of the frames. The hoist side frames are heat treated and anodized and are sealed with an anti-corrosive finish.

2.7 Cable Anti-Fouling Control

Uniform cable winding is accomplished by means of a friction roller located at the entry of the cable onto the drum which prevents the formation of loose cable turns and guards against cable fouling. The roller consists of a wear resistant elastomer bonded to a core of aluminum tubing. It is mounted on low friction bushings and is supported by an axle of corrosion resistant steel mounted to the hoist side frames.

2.8 Cable Levelwind

The cable levelwind is a driven carriage that guides the cable on and off the cable drum. The levelwind carriage is composed of a low friction, high density polymer and is constructed in the shape of a bellmouth. The carriage rides on two shafts of corrosion resistant steel supported by the hoist side frames and is propelled across the path of cable travel by a friction roller wheel which rides in the helical cable grooves of the drum as the drum rotates.

2.9 Limit Switches

The hoist assemblies contain adjustable limit switches which ensure that a minimum of $3\frac{1}{2}$ wraps of cable will remain on the drum when the hoist is operating under load and that a minimum of $1\frac{1}{2}$ wraps will remain when the hoist is operating without a load. The limit switches are located on the output end hoist side frame (opposite motor end) and are environmentally sealed in their own enclosure. The limit switches are redundant and are actuated by cams which are driven by the cable drum to assure positive and direct control. The hoist assemblies also interface with user supplied, aircraft mounted load sensors which determine the fully snubbed position.

3.0 TECHNICAL DATA - HOIST SYSTEM

3.1 Definition

The hoist system consists of a pair of hoist assemblies. Each hoist assembly consists of:

- (1) Hoist Drive Train Subassembly
- (2) Electric Motor

3.2 Hoist Assembly Performance Requirements

Power Input Requirements....	115V AC, 400 Hz, 3 phase, 39 Amps
Load, Working.....	16,250 lbs.
Load, Limit.....	40,000 lbs.
Load, Ultimate.....	60,000 lbs.
Speed.....	Up to 10 ft/min. (at Working Load)
Drum Capacity.....	22 ft. max usable (plus 1½ Inactive Turns)
Limit Switches.....	Cable fully extended; System interfaces to aircraft load sensors to sense fully retracted/ snubbed condition.

4.0 DESCRIPTION OF HOIST ASSEMBLIES

Electric motor with integral brake.

Safety load brake: fail safe mechanical type.

Hoist cables, mounting hardware, control elements, electrical harnesses and interfacing connectors are not supplied by Breeze.

5.0 ESTIMATED WEIGHT

Electric Motors	15 lbs. each
Hoist Drive Train Subassemblies	<u>225</u> lbs. each
Total Estimated Weight	240 lbs. each hoist assembly
Total Estimated System Weight	480 lbs.

System Weight less cables.

Cable to be supplied by Boeing Vertol.

6.0 APPLICABLE DOCUMENTS6.1 Government Documents

The following documents of the exact issue shown form a part of this specification to the extent specified herein. In the event of conflict between the documents referenced herein and the contents of this specification, the contents of this specification shall be considered a superseding requirement.

SPECIFICATIONS

MIL-M-7969	Motor, Alternating Current 400 Cycle 115/200 Volt System, Aircraft, General Specification for
MIL-G-21164	Grease, Molybdenum Disulfide, for Low and High Temperatures
MIL-L-23699	Lubricating Oil, Aircraft Turbine Engines, Synthetic Base

6.1 Government Documents (cont'd.)

STANDARDS

MIL-STD-704 Aircraft Electric Power Charac-
teristics

OTHER PUBLICATIONS

MIL-HDBK-5 Metallic Materials and Elements
for Aerospace Vehicle Structures

6.2 Non-Government Documents

BREEZE CORPORATIONS, INC. DRAWINGS

Hoist Installation,
Container Restraint BTD-263-648

Hoist Assembly,
Container Restraint BL-27700

Book No. 578
Appendix I

A P P E N D I X I

HOIST SYSTEM INFORMATION
SUPPLIED TO BREEZE CORPS., INC.
BY BOEING VERTOL

INFORMATION AND DATA PRESENTED IN
APPENDIX I APPEARS IN THE MAIN BODY
OF THE ECHS (SNUBBED LOAD) REPORT
(SECTIONS 4.4 and 4.5) AND IS
THEREFORE NOT REPRODUCED HERE.

Book No. 578
Appendix II

A P P E N D I X II

BULLETIN

BREEZE LOAD LOWERING
SAFETY BRAKE

BREEZE CORPORATIONS INC.

700 Liberty Avenue, Union, New Jersey 07083

Tel: 201-686-4000

BREEZE LOAD LOWERING SAFETY BRAKE

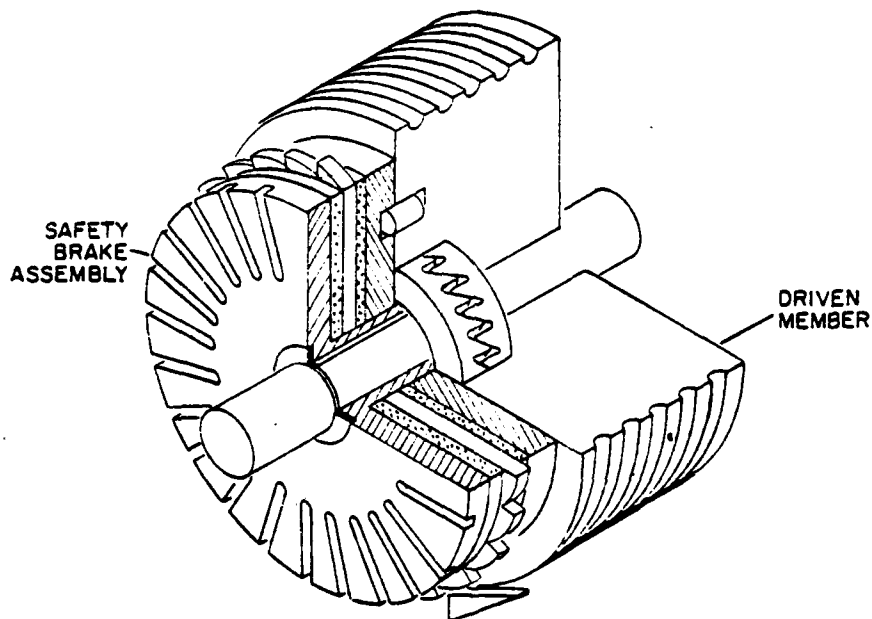

A COMPACT FAIL-SAFE FRICTION BRAKE
FOR A VARIETY OF COMMERCIAL APPLICATIONS

INTRODUCTION

The Breeze Load Lowering Safety Brake developed and manufactured by Breeze Corporations is a fail-safe mechanical friction brake and governor combination designed for hoisting or other load moving equipment where positive fail-safe requirements are of prime importance to operation of equipment and personnel safety.

The Breeze Load Lowering Safety Brake will, when used for example in a hoisting application, govern lowering speed of load to the speed of the hoist motor, securely hold the load at any desired height and prevent uncontrolled payout of the load should the motor or any other component fail to operate properly. The design of the Brake is such that during hoisting

or load moving operations the brake is tightly locked, acting as a rigid coupling. There is zero loss of mechanical advantage through the brake during such operations.

Lightweight and compact, the Breeze Load Lowering Safety Brake has been used in sophisticated hoisting equipment for commercial helicopters, one of many commercial applications ideally suited for this efficient, fail-safe device. Basically, any design concept requiring free rotation in one direction and no slippage, or rotation controlled to the maximum speed of the driver in the opposite direction may well be satisfied by use of the Breeze Safety Brake.

Design modifications and variations of the basic principles of the Brake for specific applications are almost limitless.

Each specific brake may differ in configuration, but the principles of operation are always the same. The principles of operation given here are based on a typical design concept.

The Breeze Load Lowering Safety Brake absorbs kinetic energy in direct proportion to the force (in horsepower) being put into the brake. The Brake, by virtue of its basic design, dissipates this kinetic energy by changing it into heat through the friction created between various components in the Brake. The heat is then dissipated by one of several methods depending on the size of the Brake and the particular application. Forced air, oil bath, convection or other means are used to dissipate the heat to the atmosphere. While driving the Safety

Figure No. 2, Drive Shoe and Drive Cam Assembly. This entire assembly is installed on the drive shaft and securely locked to the shaft by keys.

Installed onto the drive shoe hub are two friction plates, a toothed ratchet wheel and a load shoe which incorporates a set of jaws that mate with the jaws on the drive cam. (See figure No. 3.) These components are not secured, but are free to rotate on the drive shoe hub. The load shoe is connected to the load output member (in this application a hoist cable drum) by free floating pins which allow for axial movement of the load shoe and load shoe cam during brake operation. A ratchet pawl riding on the teeth of the ratchet wheel allows free rotation of

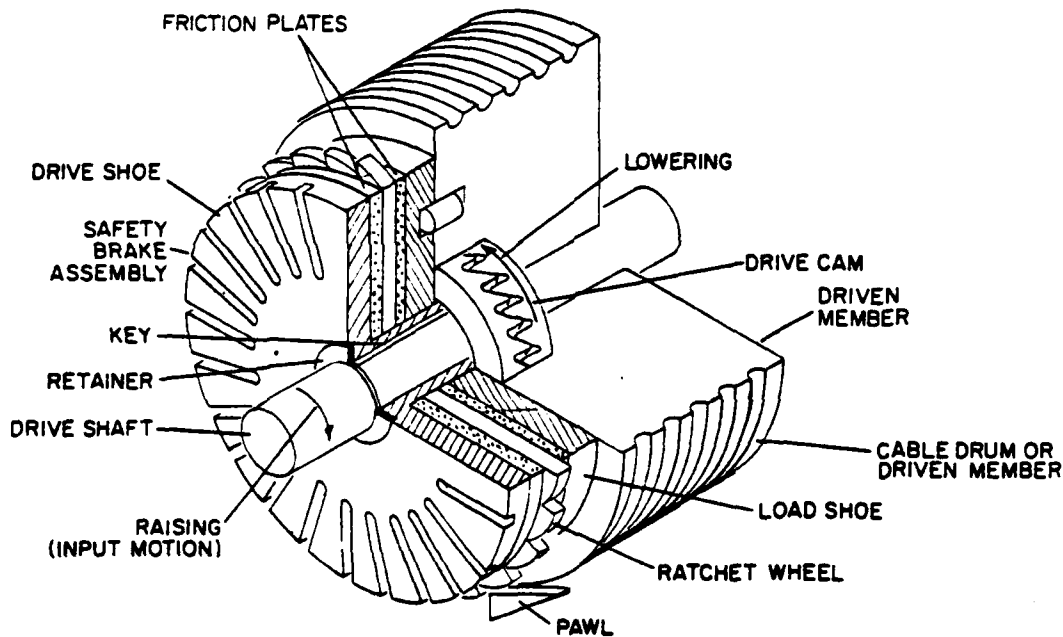

Figure 1

Brake is locked tightly together and acts as a rigid coupling. No energy is absorbed, therefore no dissipation of heat is required.

II PRINCIPLES OF DESIGN AND OPERATION

DESIGN CONCEPTS

To simplify the understanding of the Breeze Load Lowering Safety Brake, an understanding of the design and construction of the Brake is necessary. Figure No. 1 shows a cut-away view of a basic design of a brake that could be adapted to a variety of applications. For ease of understanding, the brake is shown in several stages of assembly starting with

the ratchet wheel in one direction and no-rotation in the other.

III PRINCIPLES OF OPERATION

A. Hoisting:

The drive motor is connected, either directly or through gear trains, to the drive shaft. During raising or driving of the load the drive shaft rotates in the direction shown in Figure No. 1, rotating the drive shoe and drive cam in the same direction. The load shoe tends to turn in the opposite direction as the load resists hoisting and tends to free fall. This condition causes the drive cam jaws and load shoe jaws to attempt to

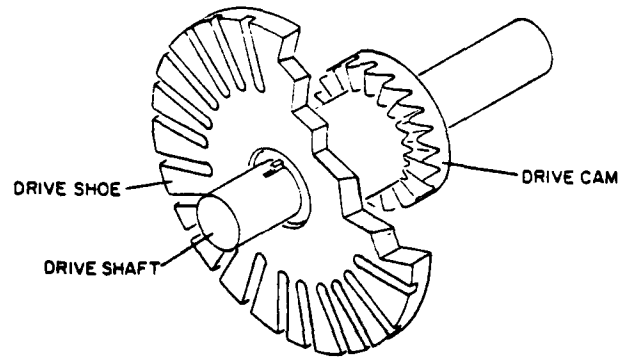

Figure 2

slide away from each other due to opposing rotation, creating an axial movement of the load shoe, friction plates and ratchet wheel toward the drive shoe. The opposing forces of the drive cam and load shoe jaws act as a wedge, forcing the brake components tightly together. (See figure 4, a.) The entire safety brake assembly is firmly locked and the load is raised or driven. The ratchet wheel pawl does not oppose rotation of the ratchet wheel during hoisting. The ratchet wheel is free running during rotation in the hoisting direction.

B. Static or Stopped Condition:

When hoisting is stopped, the load immediately tires to free fall. However, the weight of the load keeps the load shoe cam jaws wedged tightly against the drive cam jaws. The components, all forced tightly together, remain locked. The ratchet wheel, prevented from rotating counterclockwise by the ratchet pawl, becomes a braking surface. As the brake components are forced tightly together the ratchet wheel surfaces act against the friction plates, preventing any rotation.

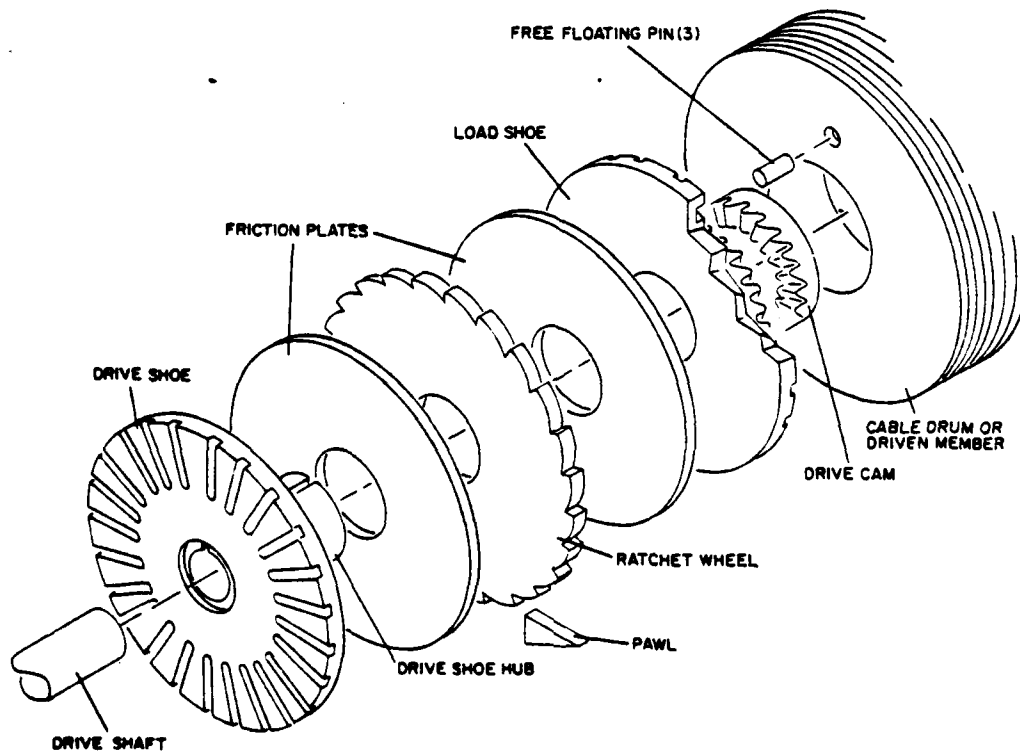

Figure 3

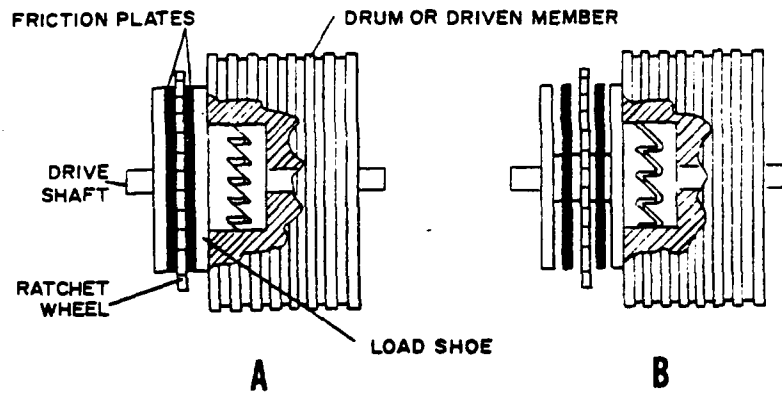

Figure 4

The load is safely held; the weight of the load itself is the force used to keep the brake tightly locked against the ratchet wheel.

C. Lowering:

When lowering the load, the brake reacts constantly, in a brake on - brake off sequence that prevents the load from descending faster than the motor speed. As the drive cam rotates as shown in Figure 1, the wedging action of the drive cam and load shoe jaw teeth against each other is eliminated. The load shoe, friction plates and ratchet wheel, released from the axial force of the wedged jaws, move apart. (See figure 4, B.) The load shoe, acted on by the weight of the load immediately starts rotating in a counterclockwise direction. The tendency of the load to free-fall causes the load shoe cam to rotate faster than the constant speed of the motor controlled drive cam. The load shoe cam jaws, as they slide along the drive cam jaws, creates the wedging condition which in turn creates the axial force that forces the brake components tightly together.

locking the brake.

The ratchet wheel, prevented from counterclockwise rotation by the pawl, again becomes a braking surface, acting upon both friction plates. Counterclockwise rotation of the load shoe is slowed almost to a stop. As the drive cam continues to rotate, the wedging action of the drive cam and load shoe jaws is again reduced. The brake components move apart and the load again tends to free-fall. As the load shoe cam again starts to rotate faster than the drive cam, the entire cycle is repeated. In actual operation, the action of the brake levels off to a condition where a continuous sliding friction is present between the friction plates and ratchet wheel surfaces, producing a smooth, constant and unaccelerated lowering of the load.

The Breeze Load Lowering Safety Brake is ideally suited for a wide variety of mechanical mechanisms used to transport heavy loads with absolute safety.

Breeze Corporations engineers are available to assist designers and engineers with the application of the brake to any load moving, lifting, or transporting equipment.

Breeze Load-Lowering Safety Brake

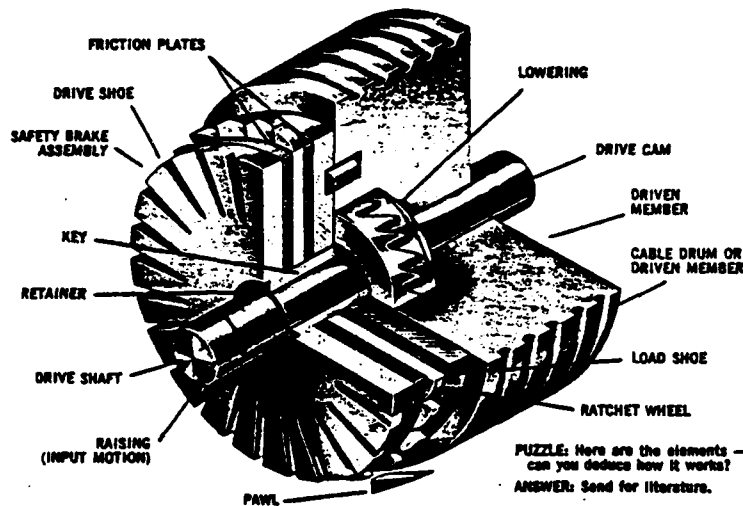

— A COMPACT FAIL-SAFE FRICTION BRAKE FOR A VARIETY OF COMMERCIAL APPLICATIONS

Here is a dependable, compact, mechanical friction-brake-and-governor combination for use with hoisting or other load-moving equipment where positive, fail-safe action is of prime importance.

Used, for example, in a hoisting application, the Breeze Load-Lowering Safety Brake will

- Govern lowering speed to hoist motor speed,
- Securely hold the load at any desired height,
- Prevent uncontrolled payout of load should motor or other component of the drive train fail.

During hoisting or load-moving, the Brake is tightly locked, with zero mechanical loss. During lowering or payout, it provides smooth, constant, unaccelerated control.

Design modifications of the basic Brake principle are virtually limitless. Send for literature, or call on Breeze engineering consultants.



BREEZE CORPORATIONS, INC.

708 Liberty Avenue, Union, New Jersey 07083 • 201-688-4000

This advertisement appearing in various sizes in Design News, Industrial Equipment News, Machine Design, Mechanical Engineering, New Equipment Digest, Product Design and Development, and Space/Aeronautics.

Book No. 578
Appendix III

A P P E N D I X III

WEIGHT ANALYSIS

1. Gear - 3rd Stage Planetary

Book No. 578
Appendix III-1

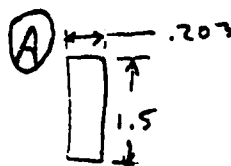
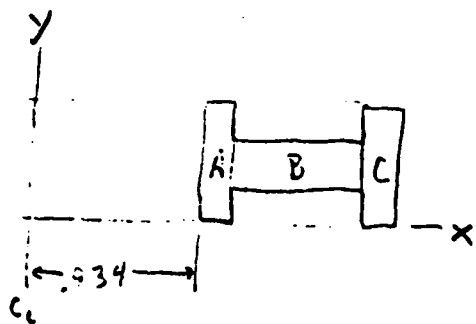
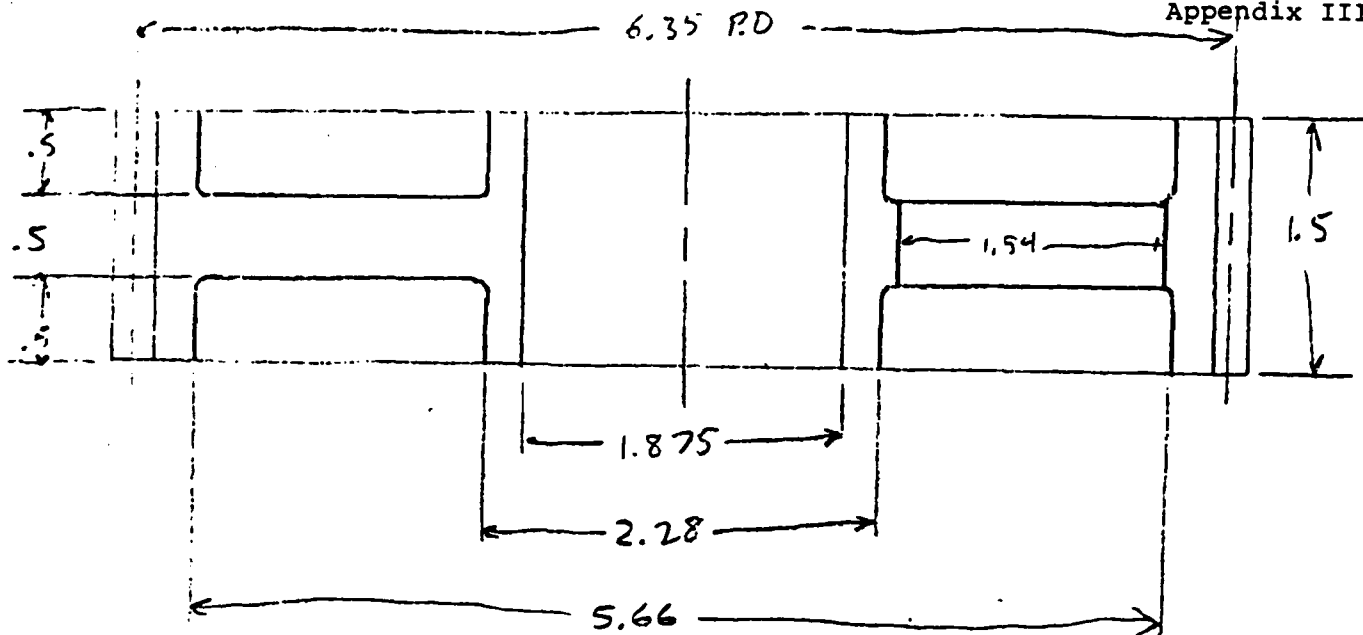

Location of C.O.G.

$$\bar{x} = \frac{.203}{2} + .934 = 1.039$$

$$Area = .203 \times 1.5 = .305 \text{ in}^2$$

(B)

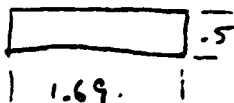

$$C.O.G.: \bar{x} = .934 + .203 + \frac{1.69}{2} = 1.986$$

$$A = .845 \text{ in}^2$$

(C)

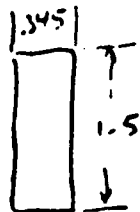

$$C.O.G.: \bar{x} = .934 + .203 + 1.69 + \frac{.345}{2} = 3.003$$

$$A = 1.5 \times .345 = .518 \text{ in}^2$$

Centroid & Total Area # 1 Gear

Component	A	\bar{x}	$\bar{x} A$
A	.305	1.039	.317
B	.845	1.986	1.678
C	<u>.518</u>	3.003	<u>1.556</u>
	$\Sigma A = 1.668$		$\Sigma \bar{x} A = 3.551$

$$\bar{x} = \frac{3.551}{1.668} = 2.129"$$

$$\begin{aligned} \text{Length of Generating Curves } C &= 2\pi r_{\text{centroid}} \\ &= 2\pi (2.129) = 13.377" \end{aligned}$$

$$\text{Volume of Gear } z = \Sigma A \times C = 1.668 \times 13.377 = 22.313 \text{ in}^3$$

(Less 1.54 DIA x .5 Lightening Holes, Volume .931 in³, 6 Holes

$$\text{Volume} = 22.313 - 6 (.931) = 16.7 \text{ in}^3$$

$$\text{Weight of Gear in Steel} = 4.75 \#$$

Centroid and Total Area #2 Gear

Component	A	\bar{x}	$\bar{x} A$
A	.109	1.013	.110
B	.337	2.18	.735
C	<u>.188</u>	3.41	<u>.641</u>
	$\Sigma A = .634$		$\Sigma \bar{x} A = 1.486$

$$\bar{x} = \frac{1.486}{.634} = 2.344$$

Length of Generating Curve = 2π Centroid
 $= 2\pi (2.344) = 14.728'$

Volume of Gear $\approx \Sigma A \times C = .634 \times 14.728 = 9.338 \text{ in}^3$

Less 1.25 DIA \times .156 Lightening Holes, Volume .191 in^3 , 6 Holes \rightarrow)

Volume = $9.338 - 6 (.191) = 8.2 \text{ in}^3$

Weight of Gear in Steel = 2.3 #

- Gear 1st Stage Planetary

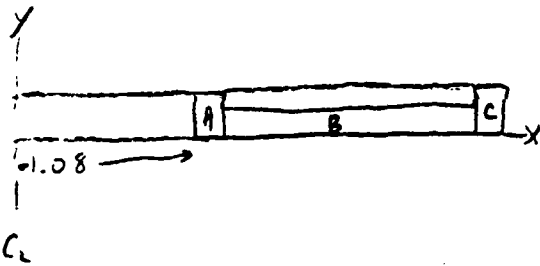
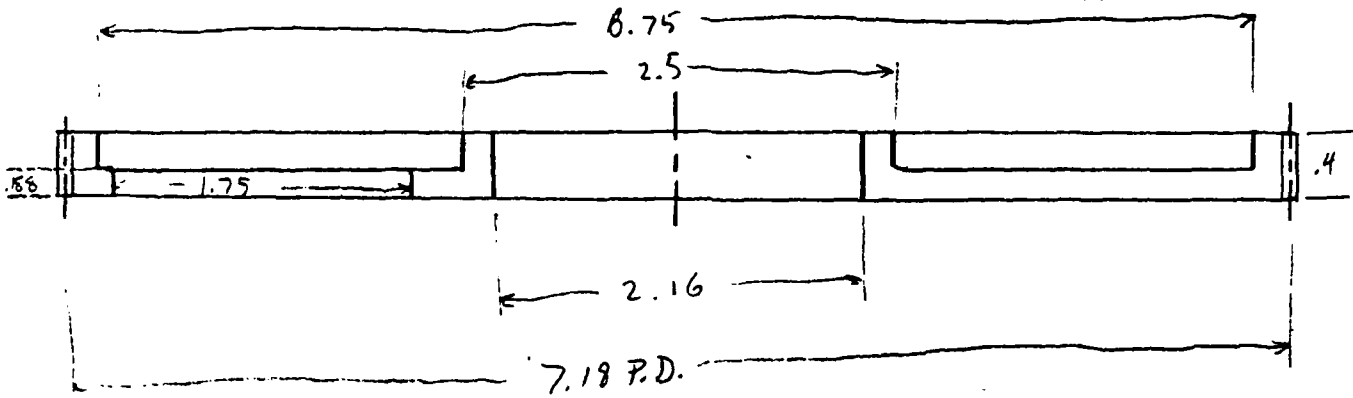

(A)



$$\text{C.O.G. } \bar{x} = 1.08 + \frac{.17}{2} = 1.165$$

$$A = .4 \times .17 = .068 \text{ in}^2$$

(B)

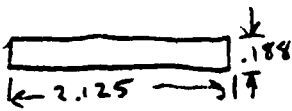

$$\text{C.O.G. } \bar{x} = 1.08 + .17 + \frac{2.125}{2} = 2.313$$

$$A = 2.125 \times .188 = .400 \text{ in}^2$$

(C)

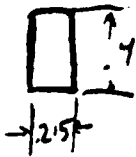

$$\text{C.O.G. } \bar{x} = 1.08 + .17 + 2.125 + \frac{.215}{2} = 3.483$$

$$A = .4 \times .215 = .086 \text{ in}^2$$

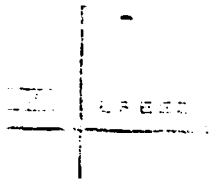

Centroid & Total Area #3 Gear

Component	A	\bar{x}	$\bar{y} A$
A	.068	1.165	.100
B	.400	2.313	.925
C	<u>.086</u>	3.483	<u>.300</u>
	$\Sigma A = .554$		$\Sigma \bar{y} A = 1.325$

$$\bar{x} = \frac{1.325}{.554} = 2.392'$$

$$\text{Length of Generating Curve } C = 2\pi r_{\text{centroid}} = 2\pi (2.392) = 15.029'$$

$$\text{Volume of Gear} = \Sigma A \times C = .554 (15.029) = 8.326 \text{ in}^3$$

(Less Lightning Holes, 1.75 DIA x .188, Volume .452 in³, 6 Holes)

$$\text{Volume} = 8.326 - 6 (.452) = 5.6 \text{ in}^3$$

$$\text{Weight of Gear in Steel} = 1.6 \#$$

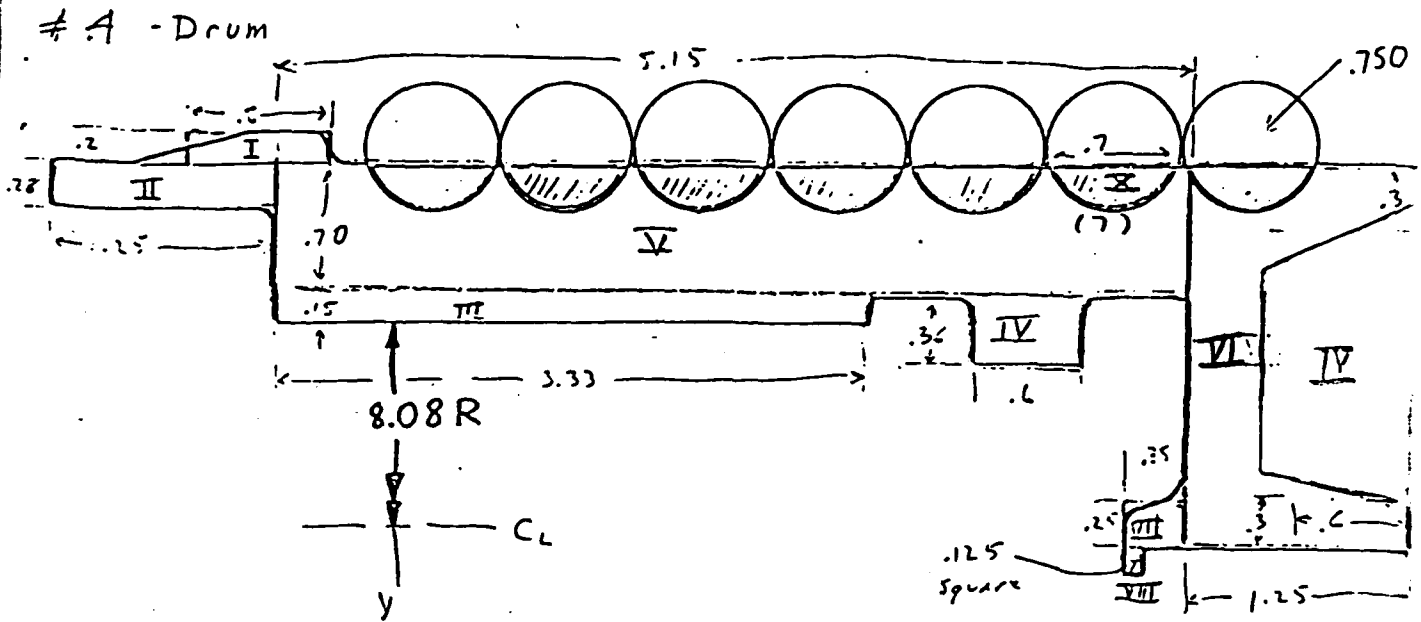

I - $A = .8 \times .2 = .16 \text{ in}^2$, C.G. $\bar{y} = 8.08 + .78 + .15 + \frac{.2}{2} = 9.11 \text{ in}$

II - $A = 1.25 \times .28 = .35 \text{ in}^2$, $\bar{y} = 8.08 + .78 + .15 - \frac{.28}{2} = 8.87 \text{ in}$

III - $A = .15 \times 3.33 = .50 \text{ in}^2$, $\bar{y} = 8.08 + \frac{.15}{2} = 8.155 \text{ in}$

IV - $A = .36 \times .6 = .216 \text{ in}^2$, $\bar{y} = 8.08 + .15 - \frac{.36}{2} = 8.05 \text{ in}$

V - $A = 5.15 \times .70 = 3.61 \text{ in}^2$, $\bar{y} = 8.08 + .15 + \frac{.70}{2} = 8.58 \text{ in}$

VI - $A = 2.2 \times 1.25 = 2.75$, $\bar{y} = 8.08 + .15 + .78 - \frac{2.2}{2} = 7.91 \text{ in}$

VII - $A = .25 \times .35 = .088 \text{ in}^2$, $\bar{y} = 8.08 + .15 + .78 - 2.2 + \frac{.25}{2} = 6.69 \text{ in}$

VIII - $A = .125^2 = .016 \text{ in}^2$, $\bar{y} = 8.08 + .15 + .78 - 2.2 - \frac{.125}{2} = 6.75 \text{ in}$

IX - $A = 1.41 \text{ in}^2$, $\bar{y} = 8.08 + .15 + .70 - .4 - \frac{1.3}{2} = 7.78 \text{ in}$

$$8) \quad \bar{X} - A = \frac{1}{2} (r l - c(r-h)) \quad \text{where } r = \frac{.750}{2}, \quad l = .01745 r \alpha, \quad c = .7$$

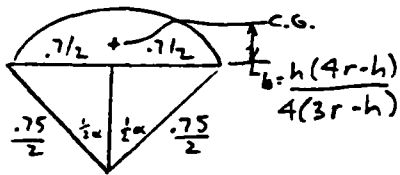

$$h = r - \frac{1}{2} \sqrt{4r^2 - c^2}$$

$$r = .375, \quad l = .903, \quad h = .240$$

$$A = \frac{1}{2} [.375 \times .903 - .7(.375 - .240)] = .122 \text{ in}^2$$

$$\bar{y} = 8.08 + .15 + .78 - \frac{(.240)(4 \times .375 - .240)}{4(3 \times .375 - .240)} = 8.925 \text{ in}$$

$$\sin \frac{1}{2} \alpha = \frac{.7/2}{.75/2}$$

$$\frac{1}{2} \alpha = .933$$

$$\frac{1}{2} \alpha = 69^\circ, \quad \alpha = 138^\circ$$

Total Area and Centroid = A - Drum

Component	A	\bar{y}	$\bar{y}A$
I	.16	9.11	1.46
II	.35	8.87	3.11
III	.50	8.16	4.08
IV	.22	8.05	1.77
V	3.61	8.58	30.97
VI	2.75	7.91	21.75
VII	.09	6.69	.60
VIII	.02	6.75	.14
IX	-1.41	7.78	-10.97
8x) X	$.122 \times 8 = -0.96$	-8.93	<u>-0.57</u>
	$\Sigma A = 5.33$		$\Sigma \bar{y}A = 44.34$

$$\bar{y} = \frac{44.34}{5.33} = 8.32 \text{ in}$$

$$V = 2\pi (5.33)(8.32) = 278.63 \text{ in}^3$$

$$Wt = (.283)(278.63) = 78.85 \text{ LB}$$

#5 - Spider
(With 3rd Stage
Sun Gear)

Book No. 578
Appendix III-10

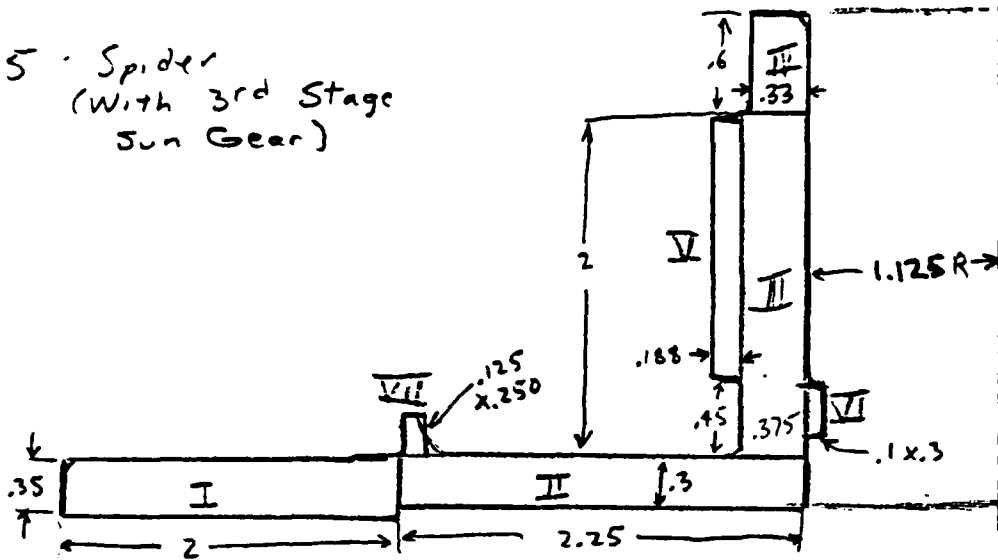

I - $A = 2 \times .35 = .7 \text{ in}^2$, $\bar{x} = 1.125 + 2.25 + \frac{2}{2} = 4.375 \text{ in}$

II - $A = 2.25 \times .3 = 6.75 \text{ in}^2$, $\bar{x} = 1.125 + \frac{2.25}{2} = 2.25 \text{ in}$

III - $A = .375 \times 2 = .75 \text{ in}^2$, $\bar{x} = 1.125 + \frac{.375}{2} = 1.313 \text{ in}$

IV - $A = .33 \times .6 = .198 \text{ in}^2$, $\bar{x} = 1.125 + \frac{.33}{2} = 1.29 \text{ in}$

V - $A = .188 \times 1.55 = .291 \text{ in}^2$, $\bar{x} = 1.125 + .375 + \frac{.188}{2} = 1.594 \text{ in}$

VI - $A = .1 \times .3 = .03 \text{ in}^2$, $\bar{x} = 1.125 - \frac{.1}{2} = 1.175 \text{ in}$

VII - $A = .125 \times .250 = .031 \text{ in}^2$, $\bar{x} = 1.125 + 2.25 - \frac{.125}{2} = 3.438 \text{ in}$

Total Area + Centroid # 5 - Spider

Component	A	\bar{x}	$\bar{x} A$
I	.7	4.375	3.063
II	.675	2.250	1.519
III	.75	1.313	.985
IV	.198	1.290	.255
V	.291	1.594	.464
VI	.03	1.175	.035
VII	<u>.031</u>	3.438	<u>.107</u>
	$\Sigma A = 2.675$		$\Sigma \bar{x} A = 6.428$

$$\bar{x} = \frac{6.428}{2.675} = 2.403$$

$$\text{VII) } V = \pi (1.275^2 - 1.125^2) \times 2.25 = 1.66 \text{ in}^3$$

$$\text{Volume of Spider} = [2\pi (2.403)(2.675)] - 1.66 = 38.73 \text{ in}^3$$

$$Wt = 38.73 \times .283 = 10.96 \text{ lb}$$

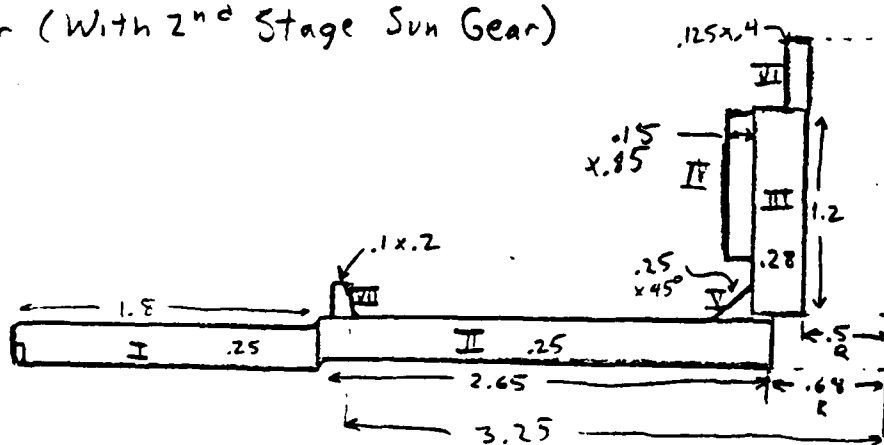
6 Spider (With 2nd Stage Sun Gear)Book No. 578
Appendix III-12

$$\text{I} \quad A = .25 \times 1.8 = .45 \text{ in}^2, \quad \bar{x} = .68 + 2.65 + \frac{1.8}{2} = 4.23 \text{ in}$$

$$\text{II} \quad A = 2.65 \times .25 = .663 \text{ in}^2, \quad \bar{x} = .68 + \frac{2.65}{2} = 2.01 \text{ in}$$

$$\text{III} \quad A = .28 \times 1.2 = .336 \text{ in}^2, \quad \bar{x} = .5 + \frac{.28}{2} = .64 \text{ in}$$

$$\text{IV} \quad A = .15 \times .85 = .128, \quad \bar{x} = .5 + .28 + \frac{.15}{2} = .855 \text{ in}$$

$$\text{V} \quad A = \frac{1}{2} \cdot .25^2 = .032 \text{ in}^2, \quad \bar{x} = \frac{.25}{3} + .28 + .5 = .863 \text{ in}$$

$$\text{VI} \quad A = .125 \times .4 = .05 \text{ in}^2, \quad \bar{x} = .5 + \frac{.125}{2} = .563 \text{ in}$$

$$\text{VII} \quad A = .1 \times .2 = .02, \quad \bar{x} = 3.25 + \frac{.1}{2} = 3.31 \text{ in}$$

Total Area + Centroid # 6 Spider

Component	A	\bar{x}	$\bar{x} A$
I	.450	4.230	1.904
II	.663	2.010	1.333
III	.336	.640	.215
IV	.128	.855	.109
V	.032	.863	.028
VI	.050	.563	.028
VII	<u>.020</u>	3.300	<u>.066</u>
	$\Sigma A = 1.679$		$\Sigma \bar{x} A = 3.683$

$$\bar{x} = \frac{3.683}{1.679} = 2.194$$

$$\text{Volume of Undrilled Spider} = 2\pi (2.194)(1.679) = 23.146 \text{ in}^3$$

$$\text{Weight of Spider in Steel} = 5.6 \text{ \#}$$

* Gear - Motor Speed Reduction

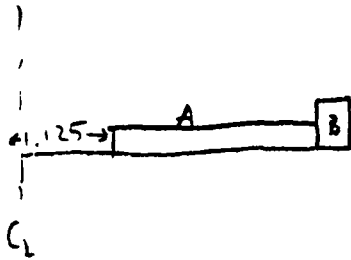
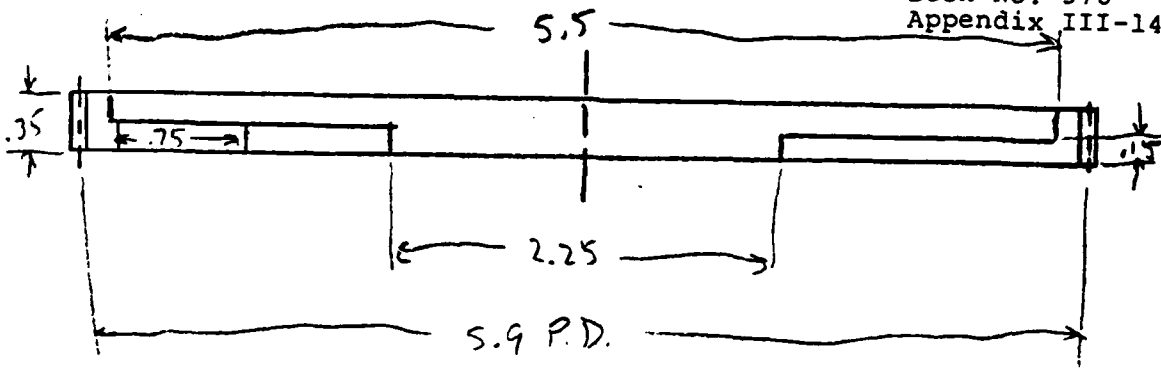

(A)

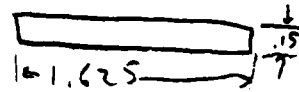

$$C.O.G. \bar{x} = 1.125 + \frac{1.625}{2} = 1.938$$

$$A = .15 \times 1.625 = .244 \text{ in}^2$$

(B)

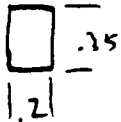

$$C.O.G. \bar{x} = 1.125 + 1.625 + \frac{.2}{2} = 2.85''$$

$$A = .35 \times .2 = .07 \text{ in}^2$$

Centroid & Total Area of Gear

Component	A	\bar{x}	$\bar{x}A$
A	.244	1.938	.473
B	<u>.070</u>	2.85	<u>.200</u>
	$\Sigma A = .314$		$\Sigma \bar{x}A = .673$

$$\bar{x} = \frac{.673}{.314} = 2.143'$$

$$\text{Length of Generating Curve} = 2\pi r_{\text{centroid}} = 2\pi (2.143) = 13.465'$$

$$\text{Volume of Gear} = .314 \times 13.465 = 4.228 \text{ in}^3$$

(Less Lightening Holes, Volume .066 in³, 6 Holes

$$\text{Volume} = 4.228 - 6 (.066) = 3.832 \text{ in}^3$$

$$\text{Weight of Gear in Steel} = 1.1 \text{ \#}$$

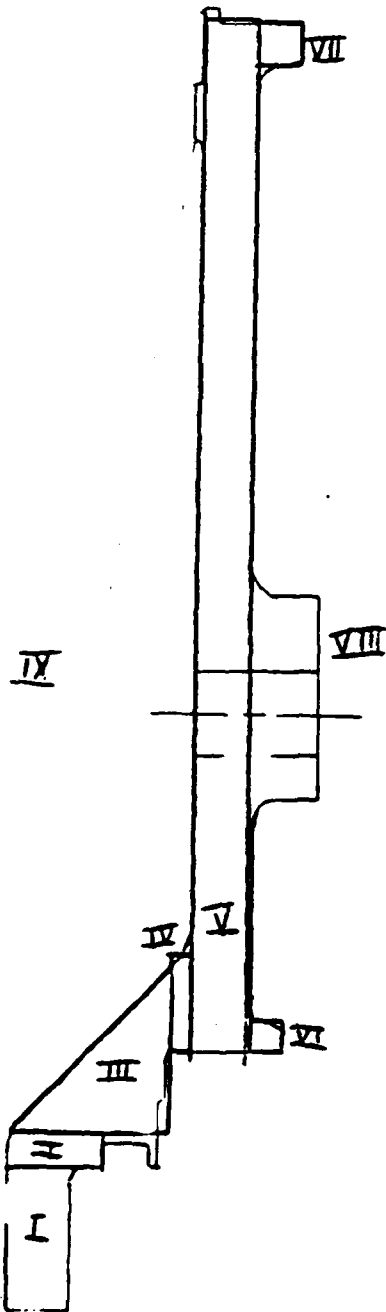
8 HOUSING (WITHOUT FLANGE) (DRIVEN END)
(CONT)

$$\text{I) } A = .375 \times .875 = .328 \text{ in}^2$$

$$\bar{y} = 8.7 - \frac{.375}{2} = 8.263 \text{ in}$$

$$\text{II) } A = .2 \times .56 = .112 \text{ in}^2$$

$$\bar{y} = 8.7 - .875 - .2/2 = 7.725 \text{ in}$$

$$\text{III) } A = \frac{1 \times .938}{2} = .469 \text{ in}^2$$

$$\bar{y} = 8.48 - 1/3 = 8.147 \text{ in}$$

$$\text{IV) } A = .125 \times .6 = .075 \text{ in}^2$$

$$\bar{y} = 8 - .6/2 = 7.7 \text{ in}$$

$$\text{V) } A = 6.1 \times .32 = 1.952 \text{ in}^2$$

$$\bar{y} = 8 - \frac{6.1}{2} = 4.95 \text{ in}$$

$$\text{VI) } A = .188^2 = .035 \text{ in}^2$$

$$\bar{y} = 8 - .188/2 = 7.906 \text{ in}$$

$$\text{VII) } A = .25^2 = .063 \text{ in}^2$$

$$\bar{y} = 2.15 - \frac{.25}{2} = 2.025 \text{ in}$$

VIII BOLT PADS (3)

$$V = \pi \frac{(1.2)^2}{4} \times .4 = .452 \text{ in}^3$$

IX RIBS (7)

$$V = 2.75 \times .31 = .853 \text{ in}^3$$

78 HOUSING (DRIVEN END)

VOLUME

COMPONENT	A	\bar{y}	$\bar{y} A$
I	.328	8.263	2.71
II	.112	7.725	.87
III	.469	8.147	3.82
IV	.075	7.7	.58
V	1.952	4.95	9.66
VI	.035	7.906	.28
VII	.063	2.025	.13
	<u>$\Sigma A = 3.03$</u>		<u>$\Sigma \bar{y} A = 18.05$</u>

$$\bar{y} = \frac{18.05}{3.03} = 5.96 \text{ in}^2$$

$$V = 2\pi (5.96)(3.03) = 113.47$$

$$+ 1.36 \text{ (3 BOLT PADS)}$$

$$+ \underline{5.97 \text{ (7 RIBS)}}$$

$$120.8 \text{ in}^3$$

FLANGE VOLUME (SEE FLANGE CALCULATIONS) = 39.2 in³

TOTAL HOUSING VOLUME = 120.8 + 39.2 = 160 in³

HOUSING WT IN AL = 160 x .102 = 16.3 LB

Housing Flanges (Also #9)

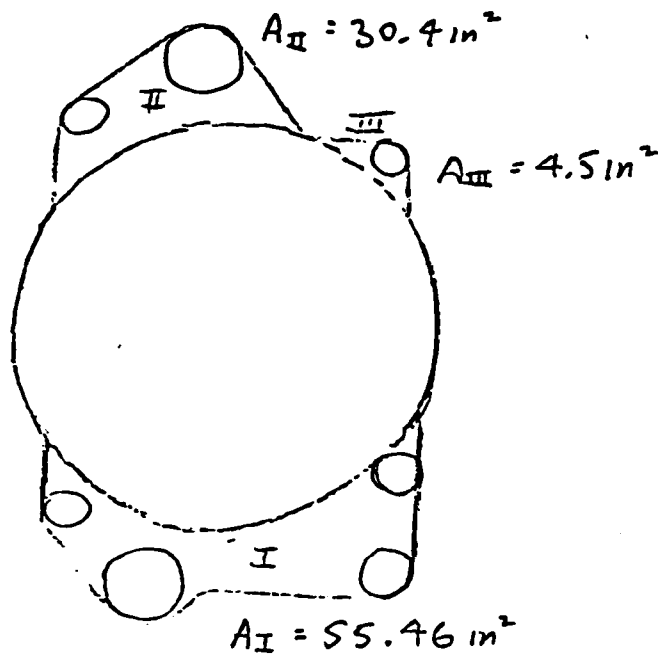

$$\text{Outer Area of Bolt Pads (5)} = \pi (1)^2 = 3.14 \text{ in}^2$$

$$\text{Outer Area of Large Mounting Pad} = \pi (1.5)^2 = 7.07 \text{ in}^2$$

$$\text{Outer Area of Small Mounting Pad} = \pi (1.225)^2 = 4.71 \text{ in}^2$$

$$\text{Flange Area} = 30.4 + 4.5 + 55.46 - [5(3.14) + 7.07 + 4.71] = 62.88 \text{ in}^2$$

$$\text{Flange Volume} = 62.88 \times .375 = 23.58 \text{ in}^3$$

$$\text{Volume of Bolt Pads (5)} = [\pi (1)^2 - \pi (.5)^2] \times .55 = 1.3 \text{ in}^3$$

$$\text{Volume of Large Mounting Pad} = [\pi (1.5)^2 - \pi (.625)^2] \times 1.125 = 6.57 \text{ in}^3$$

$$\text{Volume of Small Mounting Pad} = [\pi (1.225)^2 - \pi (.5)^2] \times .65 = 2.55 \text{ in}^3$$

$$\begin{aligned} \text{TOTAL FLANGE VOLUME} &= 23.58 + 5(1.3) + 6.57 + 2.55 \\ &= 39.2 \text{ in}^3 \end{aligned}$$

1) SIDE HOUSING (MOTOR END)

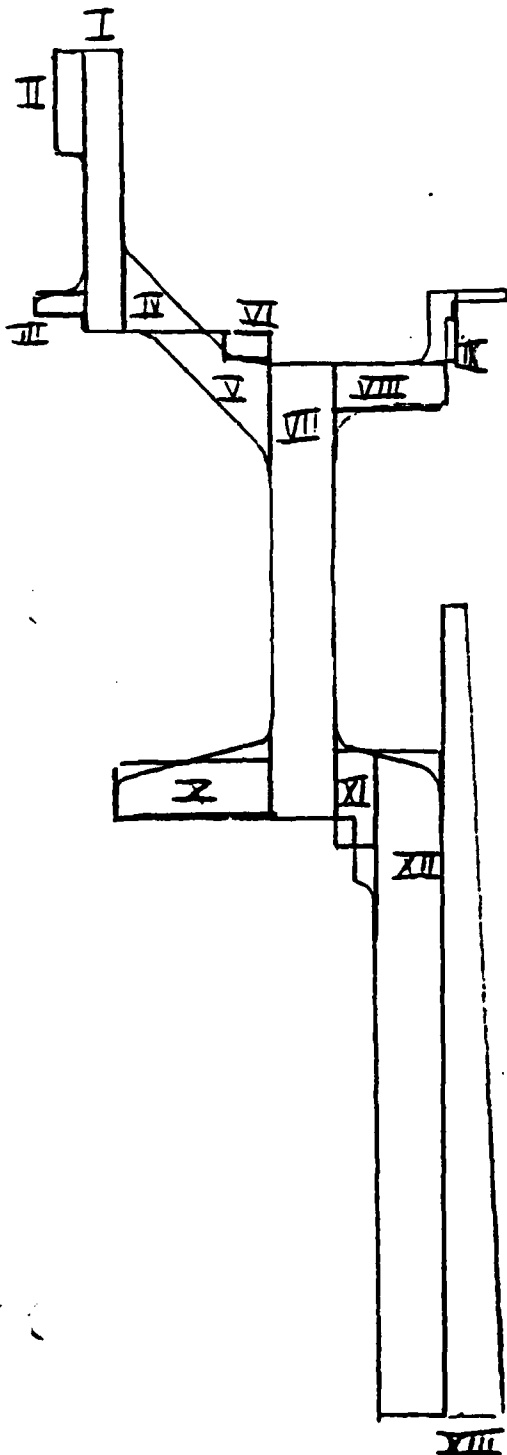

- I) $A = 1.66 \times .22 = .365 \text{ in}^2$
 $\bar{y} = 1.45 + 1.66/2 = 2.28$
- II) $A = .6 \times .188 = .113 \text{ in}^2$
 $\bar{y} = 1.45 + .6/2 = 1.75 \text{ in}$
- III) $A = .125 \times .3 = .038 \text{ in}^2$
 $\bar{y} = 3 - .125/2 = 2.938 \text{ in}$
- IV) $A = \frac{1}{2} \cdot .5^2 = .125 \text{ in}^2$
 $\bar{y} = 3.1 - .5/3 = 2.93 \text{ in}$
- V) $A = \frac{1}{2} (.875)^2 = .383 \text{ in}^2$
 $\bar{y} = 3.1 + .875/3 = 3.392 \text{ in}$
- VI) $A = .125 \times .25 = .031 \text{ in}^2$
 $\bar{y} = 3.1 + .125/2 = 3.163 \text{ in}$
- VII) $A = 2.7 \times .36 = .972 \text{ in}^2$
 $\bar{y} = 3.3 + 2.7/2 = 4.65 \text{ in}$
- VIII) $A = .65 \times .25 = .163 \text{ in}^2$
 $\bar{y} = 3.3 + .25/2 = 3.425 \text{ in}$
- IX) $A = .198 \times .45 = .085 \text{ in}^2$
 $\bar{y} = 2.875 + .45/2 = 3.1 \text{ in}$
- X) $A = .375 \times .9 = .338 \text{ in}^2$
 $\bar{y} = 6 - .375/2 = 5.813 \text{ in}$
- XI) $A = .58 \times .25 = .145 \text{ in}^2$
 $\bar{y} = 5.6 + .58/2 = 5.89 \text{ in}$
- XII) $A = 3.96 \times .4 = 1.584 \text{ in}^2$
 $\bar{y} = 5.6 + 3.96/2 = 7.58 \text{ in}$
- XIII) RIB (7)
 $V = 1.5 \times .31 = .465 \text{ in}^3$

BREEZE CORPORATION, INC.

#9 SIDE HOUSING (MOTOR END) (CONT)

COMPONENT	A	\bar{y}	$\bar{y}A$
I	.365	2.28	.832
II	.113	1.75	.198
III	.038	2.938	.112
IV	.125	2.93	.366
V	.383	3.392	1.299
VI	-.031	3.163	-.098
VII	.972	4.65	4.520
VIII	.163	3.425	.558
IX	.085	3.1	.264
X	.338	5.813	1.965
XI	.145	5.89	.854
XII	1.584	7.58	12.007

$\Sigma A = 4.28$

$\Sigma \bar{y}A = 22.877$

$\bar{y} = \frac{22.877}{4.28} = 5.35$

$V = 2\pi(4.28)(5.35) = 143.87$
 $+ \frac{3.26}{147.13} (7 \text{ RIBS})$

FLANGE VOLUME (SEE FLANGE CALCULATIONS)
 $= 39.2$

TOTAL HOUSING VOLUME = $147.13 + 39.2$
 $= 186.33 \text{ in}^3$

HOUSING WT IN AL = $186.33 \times .102 = 19 \text{ LBS}$

Housing (Brake)

Book No. 578
Appendix III-21

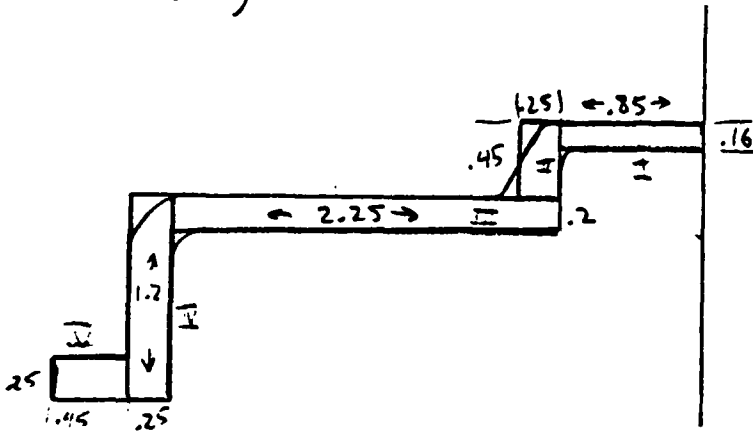

I $A = .16 \times .85 = .136 \text{ in}^2$, $\bar{x} = \frac{.85}{2} = .425 \text{ in}$

II $A = .25 \times .45 = .1125 \text{ in}^2$, $\bar{x} = .85 + \frac{.25}{2} = .975 \text{ in}$

III $A = 2.25 \times .2 = .45 \text{ in}^2$, $\bar{x} = .85 + \frac{2.25}{2} = 1.975 \text{ in}$

IV $A = 1.2 \times .25 = .3 \text{ in}^2$, $\bar{x} = .85 + 2.25 + \frac{.25}{2} = 3.225 \text{ in}$

V $A = .25 \times .45 = .1125 \text{ in}^2$, $\bar{x} = .85 + 2.25 + .25 + \frac{.45}{2} = 3.575 \text{ in}$

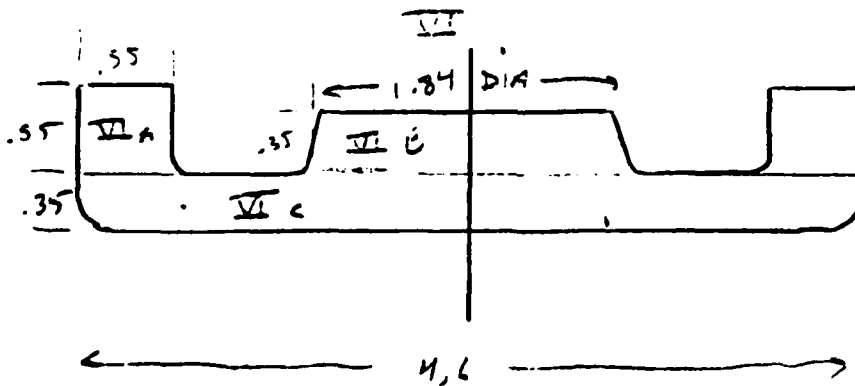

Area and Centroid # 10 Housing

Component	A	\bar{x}	$\bar{x}A$
I	.136	.425	.058
II	.113	.975	.110
III	.45	1.975	.889
IV	.30	3.225	.968
V	<u>.113</u>	2.575	<u>.404</u>
	$\Sigma A = 1.112$		$\Sigma \bar{x}A = 2.429$

$$\bar{x} = \frac{2.429}{1.112} = 2.18 \text{ in}$$

Volume of Housing Components I-V = $2\pi (2.18)(1.112) = 15.23 \text{ in}^3$

Volume of Housing Component VI: Component VI is rectangular (square) with a centrally-located hole of approx 1.5 in Dia

$$V_{VIIA} = (4)[4.6 \times .55^2] = 5.57 \text{ in}^3$$

$$V_{VII B} = \pi (.92)^2 \times .35 = .93 \text{ in}^3$$

$$V_{VII C} = 4.6 \times 4.6 \times .35 = 7.41 \text{ in}^3$$

$$V_{HOLE} = \pi (.75)^2 \times .7 = \underline{-1.24}$$

$$V_{VII} = 12.67 \text{ in}^3$$

Volume of Housing = $15.23 + 12.67 = 27.9 \text{ in}^3$

Weight of Housing in Al = 2.8 #

11

Support - 2nd Stage Planetary

Book No. 578
Appendix III-23

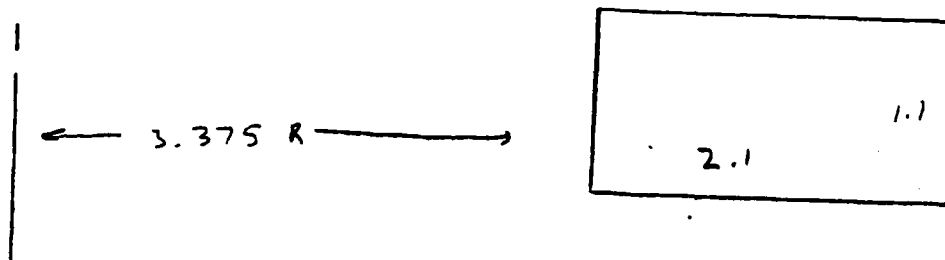

$$A = 2.1 \times 1.1 = 2.31 \text{ in}^2$$

$$\bar{x} = 3.375 + \frac{2.1}{2} = 4.425 \text{ in}$$

$$\text{Volume of Support} = 2\pi (4.425)(2.31) = 64.23 \text{ in}^3$$

$$\text{Weight of Support in Al} = 6.6 \#$$

#12 Bushing (2)

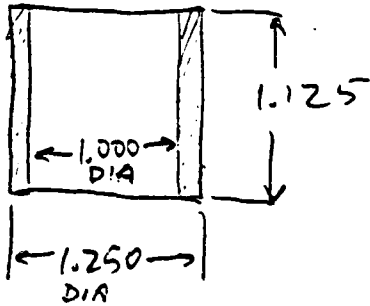

$$\text{Volume} = \left[\frac{\pi (1.250)^2}{4} - \frac{\pi (1.000)^2}{4} \right] 1.125$$

$$= [1.227 - .785] 1.125$$

$$= .497 \text{ in}^3$$

$$\text{Weight in Steel} = .14 \#$$

#13 Bushing (2)

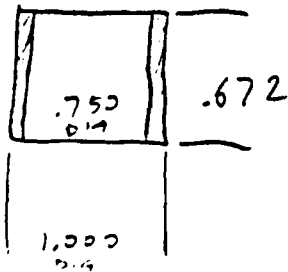

$$\text{Volume} = \left[\frac{\pi (1.000)^2}{4} - \frac{\pi (.750)^2}{4} \right] .672$$

$$= [.785 - .442] .672$$

$$= .230 \text{ in}^3$$

$$\text{Weight in Steel} = .07 \#$$

29

Support

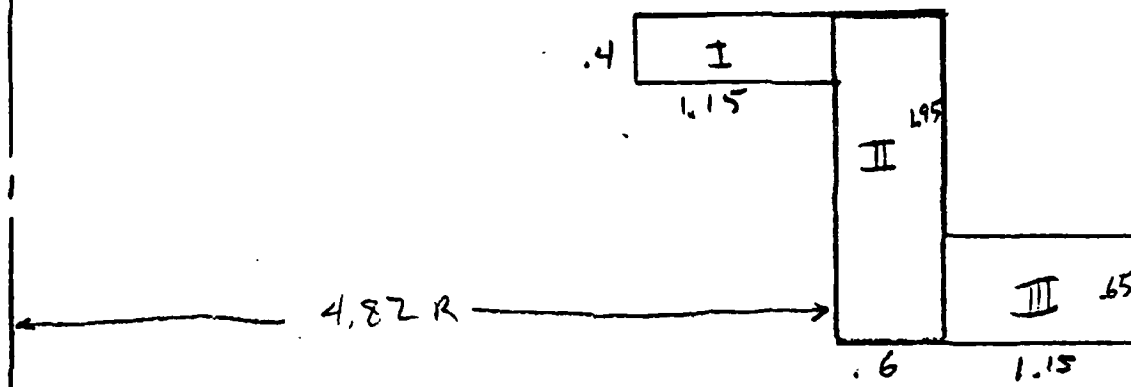
Book No. 578
Appendix III-25

$$\text{I} \quad A = 0.4 \times 1.15 = 0.46 \text{ in}^2, \quad \bar{x} = 4.82 - \frac{1.15}{2} = 4.4 \text{ in}$$

$$\text{II} \quad A = 1.95 \times 0.6 = 1.17 \text{ in}^2, \quad \bar{x} = 4.82 + \frac{0.6}{2} = 5.12$$

$$\text{III} \quad A = 1.15 \times 0.65 = 0.75 \text{ in}^2, \quad \bar{x} = 4.82 + 0.6 + \frac{1.15}{2} = 6$$

Area + Centroid # 29 Support

Component	A	\bar{x}	$\bar{x} A$
I	.46	4.4	2.02
II	1.17	5.12	6.0
III	<u>.75</u>		<u>6.0</u>
	$\Sigma A = 2.38$		$\Sigma \bar{x} A = 14.02$

$$\bar{x} = \frac{14.02}{2.38} = 5.89$$

Volume of Support = $2\pi (5.89)(2.38) = 88.08 \text{ in}^3$

Weight in $A1 = 9\#$

30 Tube (3)

Book No. 578
Appendix III-27

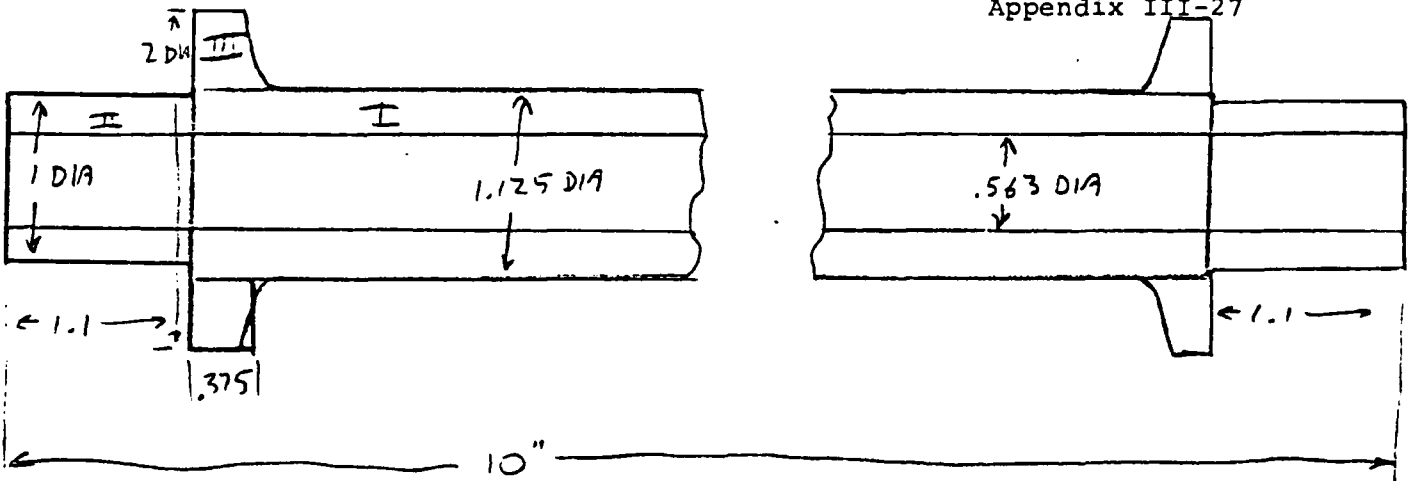

$$I \quad V = \pi \left(\frac{1.125}{2} \right)^2 (7.9) = 7.75 \text{ in}^3$$

$$- (2) \quad V = \pi \left(\frac{1}{2} \right)^2 (1.1) = .864 \text{ in}^3$$

$$III (2) \quad V = .375 \left[\pi (1)^2 - \pi (.5)^2 \right] = .884 \text{ in}^3$$

$$/ \text{Center Hole} = \pi \left(\frac{.563}{2} \right)^2 \times 10 = 2.489 \text{ in}^3$$

$$\text{Volume of Tube} = 7.75 + 2(.864) + 2(.884) - 2.489 = 8.757 \text{ in}^3$$

Weight in Al = .9#

10

32 Bushing

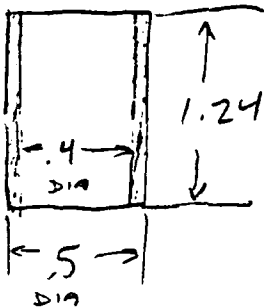

$$\text{Volume} = \left[\frac{\pi (0.5)^2}{4} - \frac{\pi (0.4)^2}{4} \right] 1.24$$
$$= [0.196 - 0.126] 1.24 = 0.087 \text{ in}^3$$

Weight in Steel = .03 #

f1-2
Support

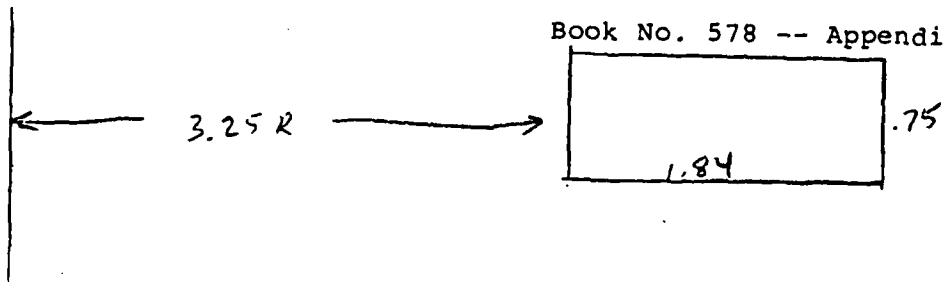

$$A = .75 \times 1.84 = 1.38 \text{ in}^2$$

$$\bar{x} = 3.25 + \frac{1.84}{2} = 4.17$$

$$\text{Volume of Support} = 2\pi(4.17)(1.38) = 36.16 \text{ in}^3$$

$$\text{Weight in Al} = 3.7 \#$$

cc

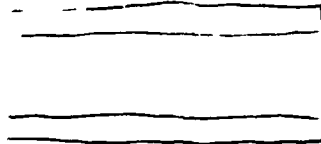
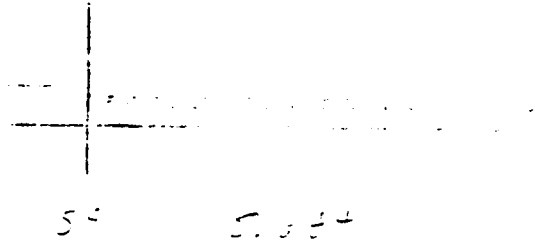

ID 1
OD 1.5
L 2.35

$$V = \left[\frac{\pi(1.5)^2}{4} - \frac{\pi(1)^2}{4} \right] 2.35 = 2.31 \text{ in}^3$$

Weight in steel = .66 #

5 Shaft-Brake (With 1st Stage Sun Gear)

Book No. 578
Appendix III-31

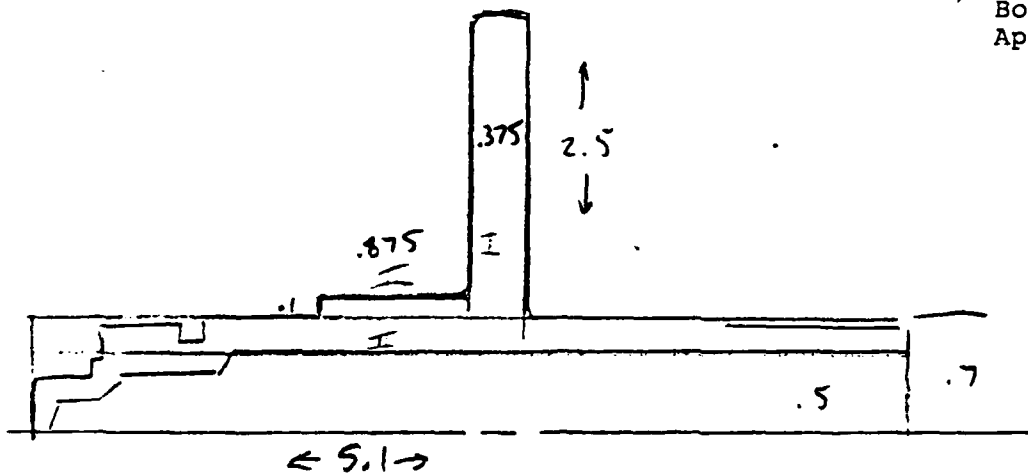

$$I \quad V = \pi (3.2)^2 - \pi (.7)^2 (.375) = 11.5 \text{ in}^3$$

$$II \quad V = \pi (.7)^2 - \pi (.5)^2 (5.1) = 3.85 \text{ in}^3$$

$$III \quad V = \pi (.8)^2 - \pi (.7)^2 (.975) = .412 \text{ in}^3$$

$$V = 11.5 + 3.85 + .412 = 15.76 \text{ in}^3$$

Weight in Steel = 4.5 #

10

5' Spline

Book No. 578
Appendix III-32

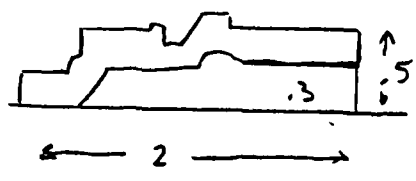

$$V = \pi (.5)^2 - \pi (.3)^2 (2) = 1 \text{ in}^3$$

Weight in Steel = .28 #

SUMMARY OF WEIGHTS

COMPONENT AND MATERIAL (IF APPLICABLE)	ESTIMATED WT (LB)
BEARINGS AND HARDWARE	30.8
PLANET GEARS (STEEL)	
1. 4x4.75 LB	19.0
2. 3x2.3 LB	6.9
3. 3x1.6 LB	4.8
4. CABLE DRUM (STEEL)	78.85
5. SPIDER (STEEL)	10.96
6. SPIDER (STEEL)	6.6
7. GEAR (STEEL)	1.1
8. HOUSING (ALUMINUM)	16.3
9. HOUSING (ALUMINUM)	19.0
10. HOUSING (ALUMINUM)	2.8
11. SUPPORT (ALUMINUM)	6.6
12. BUSHING (STEEL)	2x.14 LB .28
13. BUSHING (STEEL)	2x.07 LB .14
29. SUPPORT (ALUMINUM)	9.0
30. TUBE (ALUMINUM)	3x.9 LB 2.7
52. SUPPORT (AL)	3.7
54. SHAFT (STEEL)	.66
55. SPLINE (STEEL)	4.5
56. SPLINE (STEEL)	2.8
57. MOTOR	<u>15.0</u>
TOTAL ESTIMATED WEIGHT	239.97
	≈ 240 LB

Book No. 578
Appendix IV

A P P E N D I X I V

S T R E S S A N A L Y S I S

WELLS CORPORATION, INC
HOIST REACTIONS

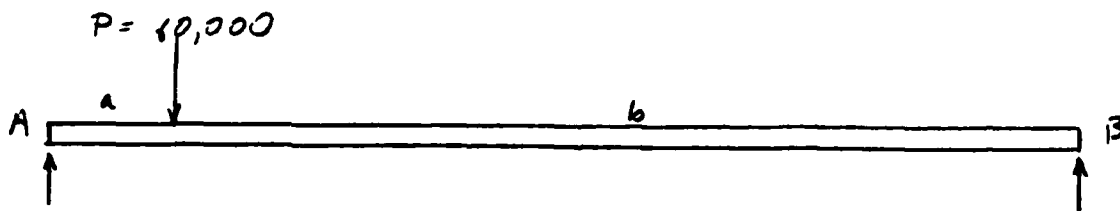
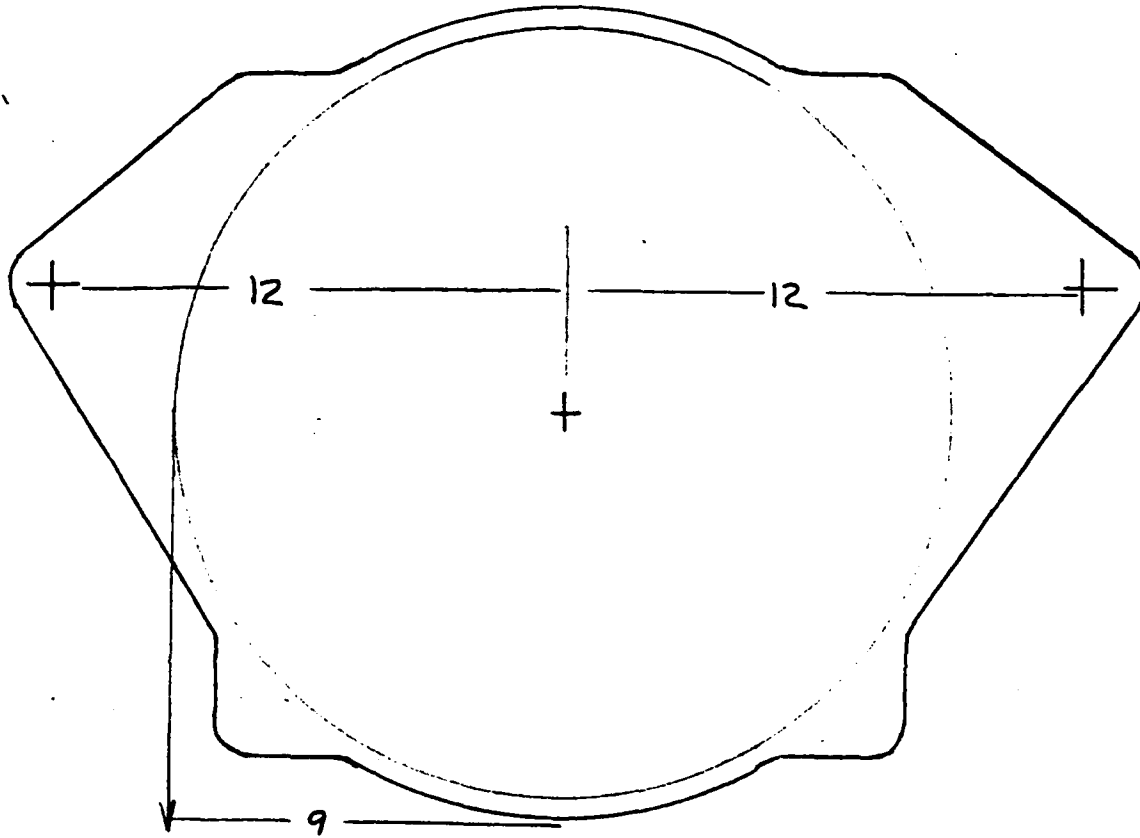

$$\sum EM = 0 \therefore -60,000 \times 3 + B(24)$$

$$B = \frac{60,000 \times 3}{24} = 7500 \#$$

$$A = 60,000 - 7500 = 52,500 \#$$

(5000 # @ limit)

(35,000 # @ limit) ..

HIGH STRESS AREA

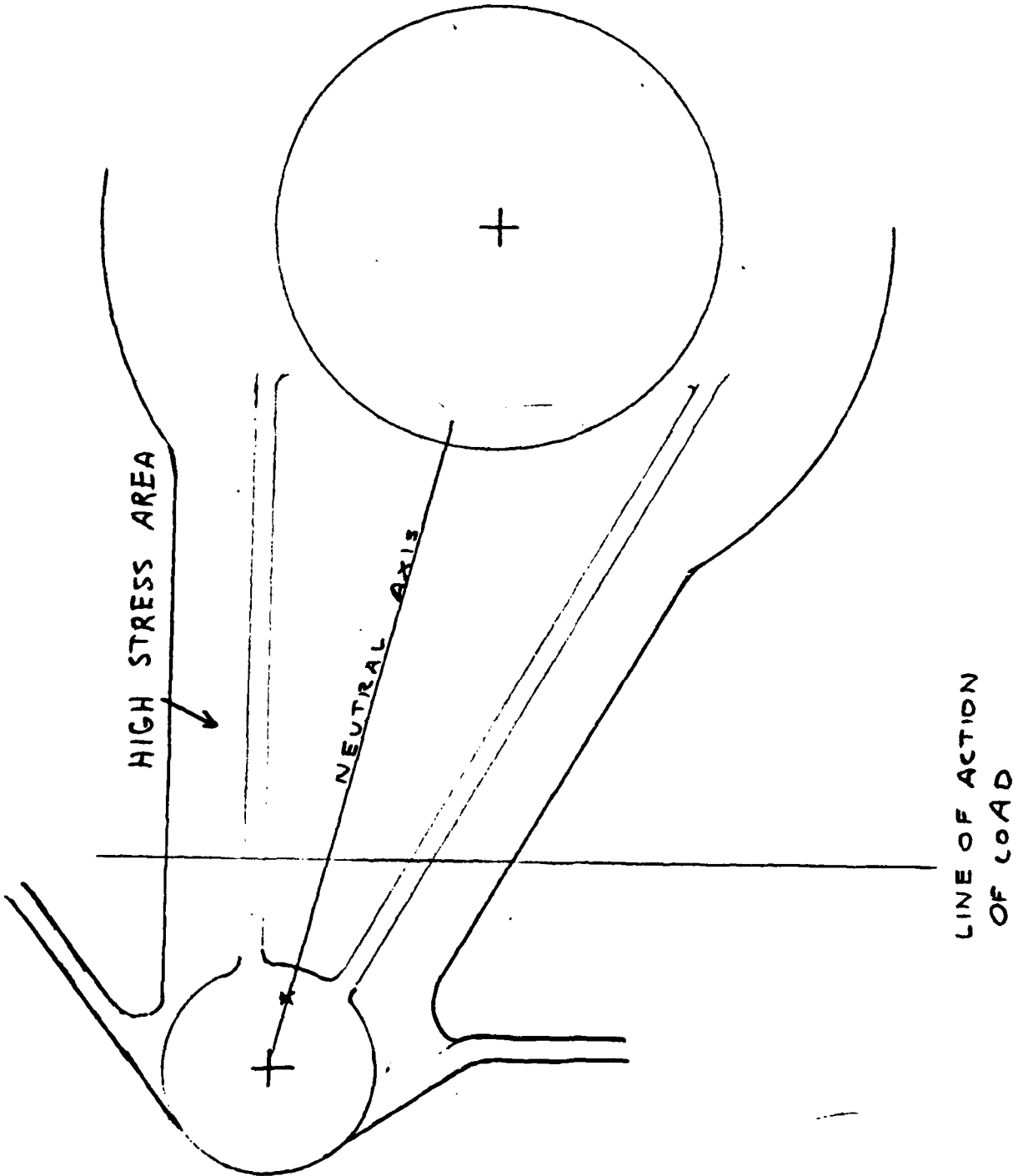

HEIGHT OF HIGH STRESS AREA AT NARROWEST PT 5.5 in

SHEAR @ N.P. = 52,500 lb

BENDING @ N.P. = $\frac{60,000(3)(21)}{24} = 157,500 \text{ in-LBS}$

MAT'L - 7075-T6 (MIL HDBK 5); STRENGTH = 75,000 psi SHEAR
43,000 psi TENS
MINIMUM CROSS-SECTION REQUIRED TO RESIST SHEAR

$A = \frac{52,500 \text{ lb}}{43,000 \text{ lb/in}^2} = 1.22 \text{ in}^2$

AND MINIMUM THICKNESS REQUIRED = $\frac{1.22}{4.8} = .255 \text{ in}$

BENDING STRESS = $\frac{MC}{I} = \frac{157,500 \left(\frac{5.5}{2} \right)}{I} = \frac{433,125}{I}$

MINIMUM I REQ'D TO RESIST BENDING

$I = \frac{433,125}{75,000} = 5.775$



$I = \frac{bh^3}{12} = \frac{b(5.5)^3}{12} = 5.78 \text{ in}^4$

$b = \frac{5.775(12)}{(5.5)^3} = .4165 \text{ in} \approx .420 \text{ in}$

THICKNESS REQ'D = .420 in

ACT. WIDTH REQ'D @ LOAD THICKNESS

$$T @ \text{LOAD WIDTH} = \frac{52,500}{.42 \times W} = 43,000 \text{ psi}$$

$$W = \frac{52,500}{.42 \times 43,000} = 2.90 \text{ in}$$

$$\sigma @ \text{LOAD WIDTH} = \text{MAX BENDING MOMENT} = \frac{60000(3)(12)}{24} = 157,500 \text{ in-lb}$$

$$C = \frac{1}{2}h, I = \frac{bh^3}{12}$$

$$\frac{M_C}{I} = \frac{(12 \times) 157,500 (\frac{1}{2}h)}{.42(h^3)} = \frac{945,000 h}{.42(h^3)} = 75,000 \text{ psi}$$

$$75,000 = \frac{945,000}{.42(h^2)}$$

$$h = \left(\frac{945,000}{75,000(.42)} \right)^{\frac{1}{2}} = 3.11 \text{ in}$$

ACTUAL STRESSES $T_{lim} = \frac{35,000}{5.5 \times .42} = 15,155 \text{ psi}$

$$T_{ult} = \frac{52,500}{5.5 \times .42} = 22,730 \text{ psi}$$

$$\sigma_{lim} = \frac{105,000(5.5/2)}{5.82} = 99,615 \text{ psi}$$

$$\sigma_{ult} = \frac{157,500(5.5/2)}{5.82} = 74,420 \text{ psi}$$

$$I = \frac{.42(5.5)^3}{12} = 5.82 \text{ in}^4$$

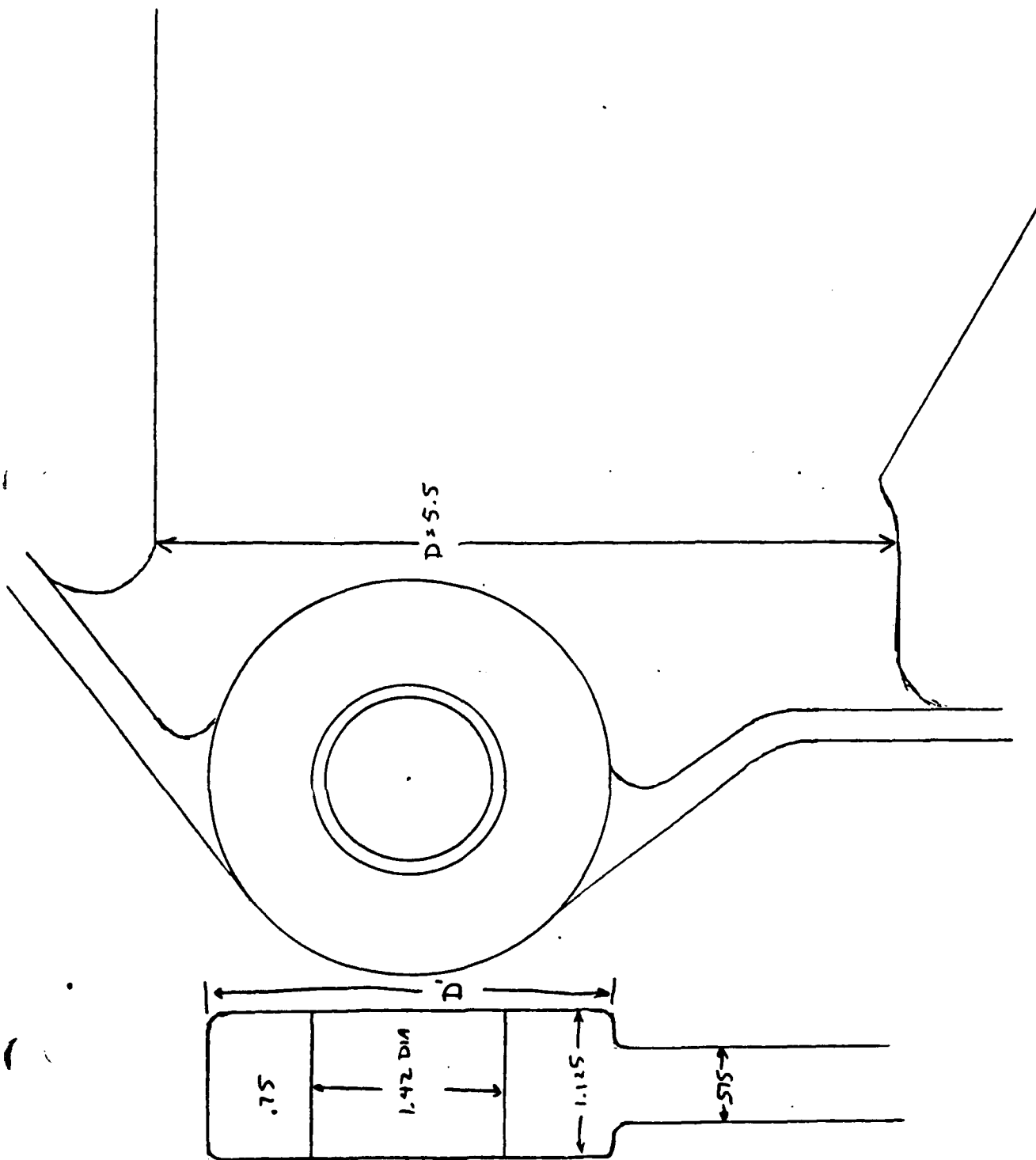

STRESS - PRIMARY MOUNTING BOSS (SHEAR)

$$\tau = \frac{P}{A} = \frac{35,000}{1.42 \times 1.125} = 21,910 \text{ psi LIMIT}$$

$$\frac{52,500}{1.42 \times 1.125} = 32,865 \text{ psi ULTIMATE}$$

STRESS CONCENTRATION FACTOR K AT PIN BUSHING

$$\frac{H}{D'} = \frac{1.375}{2.75} = .5 \quad \frac{r}{D'} = \frac{1.42}{2.75} = .516$$

$$K = 2.6$$

$$\begin{aligned} \text{STRESS AT PIN} &= 21,910 \times 2.6 = 56,966 \text{ psi LIMIT.} \\ &32,865 \times 2.6 = 85,449 \text{ psi ULTIMATE} \end{aligned}$$

HOUSING SURROUNDING MOUNTING BOSS

$$\tau = \frac{P}{A} = \frac{35,000}{5.5 \times .575} = 11,067 \text{ psi LIMIT}$$

$$\frac{52,500}{5.5 \times .575} = 16,600 \text{ psi ULTIMATE}$$

STRESS CONCENTRATION FACTOR K

$$A_{\text{BEAD}} = .75 (1.125 - .575) = .4125$$

$$A_{\text{HOLE}} = 1.42 (.575) = .8165$$

$$\frac{A_{\text{BEAD}}}{A_{\text{HOLE}}} = \frac{.4125}{.8165} = .51 \quad K = 1.53$$

$$\begin{aligned} \text{STRESS} &= 11,067 \times 1.53 = 16,933 \text{ psi LIMIT} \\ &16,600 \times 1.53 = 25,398 \text{ psi ULTIMATE} \end{aligned}$$

$$\begin{aligned} \text{FACTORS OF SAFETY} & \quad 2.54 \text{ LIMIT} \\ & \quad 1.69 \text{ ULTIMATE} \end{aligned}$$

CABLE DRUM - INTERNAL GEAR

$$\text{MAX TOOTH LOAD} = \frac{P}{4 \text{ planets}} \times \frac{9 \text{ (cable p.d.)}}{9.063 \text{ (ring p.d.)}} = \begin{array}{l} 5445 \text{ LB WORKING} \\ 11,160 \text{ LB LIMIT} \\ 16,745 \text{ LB ULTIMATE} \end{array}$$

TOOTH BEAM STRENGTH

$$F_b = S_b y p = 170,000 (1.5) (.163) \left(\frac{\pi}{8}\right) = 16,320 \text{ LB TO DEFORMATION}$$

$$= 190,000 (1.5) (.163) \left(\frac{\pi}{8}\right) = 18,240 \text{ LB TO FAILURE}$$

DYNAMIC LOAD (WORKING LOAD ONLY)

REQ'D CABLE SPEED = 10 FPM
 RPM = 10 FPM / 4.71 ft/Rev = 2.1
 $V = (\pi (129/8) / 12) \times 2.1 = 8.9 \text{ FPM}$
 ESTIMATED ERROR IN ACTION .0005 IN, C = 860

$$W_d = \frac{.05V (FC+W)}{.05V + \sqrt{FC+W}} + W, \quad FC+W = 1.5(860) + 5445 = 6735$$

$$= 36 + 5445 = 5481 \text{ LB}$$

FACTORS OF SAFETY

WORKING (TO ALLOWABLE WORKING LOAD) = $18,240 \times \frac{600}{800 + 8.9} = 17,970 \text{ LB}$

$$F_{S \text{ WORKING}} = \frac{17,970}{5481} = 3.2$$

LIMIT (TO DEFORMATION)

$$F_{S \text{ LIMIT}} = \frac{16,320}{11,160} = 1.4$$

ULTIMATE (TO FAILURE)

$$F_{S \text{ ULT}} = \frac{18,240}{16,745} = 1.09$$

CABLE DRUM - SHEAR AND BENDING STRESSES

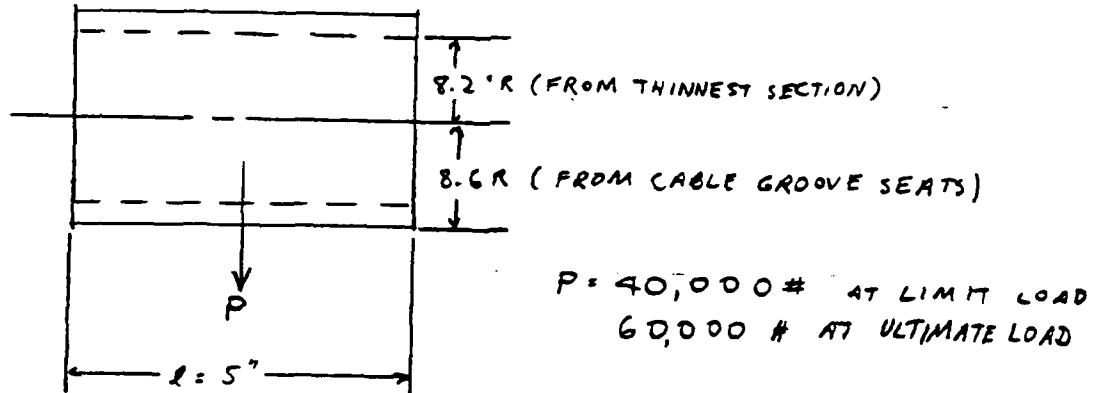

MAXIMUM SHEAR AND BENDING OCCUR WITH CABLE CENTERED

$$\text{SHEAR} = \frac{P}{2} = 20,000 \# \text{ LIMIT}$$

$$30,000 \# \text{ ULTIMATE}$$

$$A_{cs} = \pi (r_o^2 - r_i^2) = 21.1 \text{ in}^2$$

$$I_{min} = \frac{\pi (r_o^4 - r_i^4)}{4} = 745 \text{ in}^4$$

$$\text{SHEAR STRESS} = \frac{\text{SHEAR}}{A} = 950 \text{ psi LIMIT}$$

$$1422 \text{ psi ULTIMATE}$$

$$\text{BENDING STRESS} = \frac{Mc}{I} = 580 \text{ psi LIMIT}$$

$$870 \text{ psi ULTIMATE}$$

CABLE DRUM - CABLE PRESSURE STRESSES

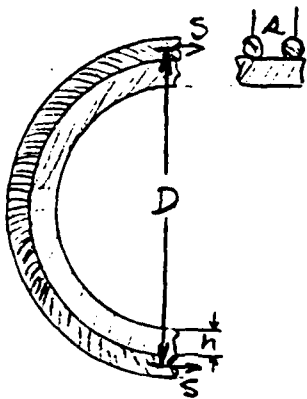

$$D = 18''$$

$$S = 40,000 \# \text{ LIMIT}$$

$$60,000 \# \text{ ULTIMATE}$$

$$a = .75''$$

$$h = .45''$$

$$\text{BENDING STRESS} = .96 S \sqrt{\frac{1}{D^2 h^6}}$$

$$= .96 S \sqrt{\frac{1}{(18)^2 (.45)^6}} = .750 S$$

$$= 30,000 \text{ psi LIMIT}$$

$$45,000 \text{ psi ULTIMATE}$$

$$\text{COMPRESSION (SHEAR) STRESS} = .85 \frac{S}{h a}$$

$$= \frac{.85 S}{(.45 \times .75)} = 2.5 S$$

$$= 100,000 \text{ psi LIMIT}$$

$$150,000 \text{ psi ULTIMATE}$$

CABLE DRUM - TORSIONAL STRESSES

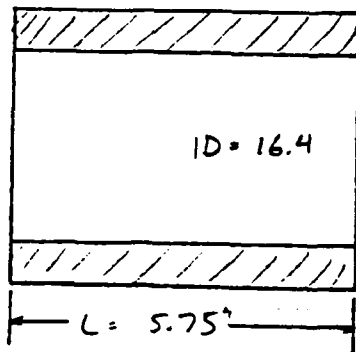

$$T = 40,000 \times 8.6 = 344,000 \text{ in Lb} \quad \text{LIMIT}$$
$$60,000 \times 8.6 = 516,000 \text{ in Lb} \quad \text{ULTIMATE}$$

$$\text{SHEAR STRESS} = \frac{2 T r_o}{\pi (r_o^4 - r_i^4)}$$
$$= 1985 \text{ psi} \quad \text{LIMIT}$$
$$2977 \text{ psi} \quad \text{ULTIMATE}$$

CABLE DRUM - COMBINED STRESSES

TOTAL SHEAR

$$S_s = 950 + 100,000 + 1985 = 102,935 \text{ psi LIMIT}$$

$$1422 + 150,000 + 2977 = 154399 \text{ psi ULTIMATE}$$

TOTAL BENDING

$$S_b = 580 + 30,000 = 30,580 \text{ psi LIMIT}$$

$$870 + 45,000 = 45870 \text{ psi ULTIMATE}$$

COMBINED STRESSES

$$S_c = \sqrt{\left(\frac{1}{2}S_b\right)^2 + S_s^2} = 104,065 \text{ psi LIMIT}$$

$$156,095 \text{ psi ULTIMATE}$$

CONCENTRATION FACTORS

BENDING

$$h/r = .75, h/r = 1$$

$$K = \frac{1 + 2\sqrt{h/r}}{1 + \sqrt{h/r}} = 1.5$$

TORSION

$$D = 17.2, r = .75/2$$

$$K = \frac{2D}{D + 2r} = 1.9$$

ADJUSTED TOTAL STRESSES

$$\text{SHEAR } S_s = 950 + 100,000 + 3772 = 104,722 \text{ psi LIMIT}$$

$$1422 + 150,000 + 5656 = 157,078 \text{ psi ULTIMATE}$$

$$\text{BENDING } S_b = 45870 \text{ psi LIMIT}$$

$$68805 \text{ psi ULTIMATE}$$

ADJUSTED COMBINED STRESS

$$S_c = 107,205 \text{ psi LIMIT}$$

$$160,800 \text{ psi ULTIMATE}$$

FACTORS OF SAFETY

$$\text{MAT'L } .9310 \text{ ST'L ALY } S_y = 170,000 \text{ psi}$$

$$S_{ULT} = 190,000 \text{ psi}$$

$$\text{FS LIMIT (AGAINST DEFORMATION)} = \frac{170,000}{104,722} = 1.62$$

$$\text{FS ULT (AGAINST FAILURE)} = \frac{190,000}{157,078} = 1.21$$

BEHOLDSTOR DRIVETRAIN

UNDER LIMIT AND ULTIMATE LOADS (STATIC ONLY;
HOIST OPERATION NOT REQD)

REDUCTIONS

$$3^{\text{rd}} \text{ STAGE } \frac{N_R}{N_s} + 1 = \frac{129}{27} + 1 = 5.778$$

$$2^{\text{nd}} \text{ STAGE } \frac{N_R}{N_s} + 1 = \frac{129}{15} + 1 = 9.6$$

$$1^{\text{ST}} \text{ STAGE } \frac{N_R}{N_s} + 1 = \frac{250}{20} + 1 = 13.5$$

$$\text{INPUT } \frac{N_9}{N_P} = \frac{95}{15} = 6.33$$

$$\text{TOTAL RATIO} = 6.33 [(13.5 \times 9.6 \times 5.778) - 1] = 4734:1$$

APPLIED TORQUES @ ULTIMATE LOAD

DRUM 540,000 IN LB

$$3^{\text{rd}} \text{ STAGE PINION } \frac{540,000}{5.778} = 93,460 \text{ in LB}$$

$$2^{\text{nd}} \text{ STAGE PINION } \frac{540,000}{(5.778)(9.6)} = 9735 \text{ in LB}$$

$$1^{\text{ST}} \text{ STAGE PINION } \frac{540,000}{(5.778)(9.6)(13.5)} = 721 \text{ in LB}$$

$$\text{INPUT PINION } \frac{540,000}{4734} = 114 \text{ in LB}$$

APPLIED TORQUES AT LIMIT LOAD

DRUM 360,000 in LB

$$3^{\text{rd}} \text{ STAGE PINION } 62300 \text{ in LB}$$

$$2^{\text{nd}} \text{ STAGE PINION } 6490 \text{ in LB}$$

$$1^{\text{ST}} \text{ STAGE PINION } 480 \text{ in LB}$$

$$\text{INPUT PINION } 76 \text{ in LB}$$

TOOTH LOADS AT ULTIMATE LOAD

$$3^{\text{rd}} \text{ STAGE PINION } \frac{93460}{1.688 \times 4} = 13840 \text{ lb}$$

$$2^{\text{nd}} \text{ STAGE PINION } \frac{9735}{.939 \times 3} = 3460 \text{ lb}$$

$$1^{\text{st}} \text{ STAGE PINION } \frac{721}{.625 \times 3} = 385 \text{ lb}$$

$$\text{INPUT } \frac{119}{.469} = 243 \text{ lb}$$

TOOTH LOADS AT LIMIT LOAD

$$3^{\text{rd}} \text{ STAGE PINION } 9230 \text{ lb}$$

$$2^{\text{nd}} \text{ STAGE PINION } 2310 \text{ lb}$$

$$1^{\text{st}} \text{ STAGE PINION } 260 \text{ lb}$$

$$\text{INPUT PINION } 165 \text{ lb}$$

STATIC BEAM STRESSES AT ULTIMATE LOAD

$$3^{\text{rd}} \text{ STAGE PINION } S_1 = \frac{13840}{(1.5X.1367)(\frac{\pi}{8})} = 173,000 \text{ psi}$$

$$2^{\text{nd}} \text{ STAGE PINION } S_2 = \frac{3460}{(.75)(.111)(\frac{\pi}{8})} = 105,835 \text{ psi}$$

$$1^{\text{st}} \text{ STAGE PINION } S_1 = \frac{385}{(.5)(.125)(\frac{\pi}{16})} = 31,370 \text{ psi}$$

$$\text{INPUT PINION } S_2 = \frac{243}{.5(.111)(\frac{\pi}{16})} = 22,300 \text{ psi}$$

STATIC BEAM STRESSES AT LIMIT LOAD

$$3^{\text{rd}} \text{ STAGE PINION } S_1 = 115,220 \text{ psi}$$

$$2^{\text{nd}} \text{ STAGE PINION } S_2 = 70,660 \text{ psi}$$

$$1^{\text{st}} \text{ STAGE PINION } S_1 = 21,190 \text{ psi}$$

$$\text{INPUT PINION } S_2 = 15,140 \text{ psi}$$

STATIC BEAM STRENGTHS - DEFORMATION LIMIT

$$E4340 S_y = 190,000 \text{ psi} \quad (180,000 - 200,000 \text{ psi MIL HDBK 5})$$

$$\begin{aligned} 3^{\text{rd}} \text{ STAGE PINION } F_{b_y} &= (190,000)(1.5)(.136)\left(\frac{\pi}{8}\right) \\ &= 7522.5 \text{ LB} \end{aligned}$$

$$\begin{aligned} 2^{\text{nd}} \text{ STAGE PINION } F_{b_y} &= (190,000)(.75)(.111)\left(\frac{\pi}{8}\right) \\ &= 6210 \text{ LB} \end{aligned}$$

$$\begin{aligned} 1^{\text{st}} \text{ STAGE PINION } F_{b_y} &= (190,000)(.5)(.125)\left(\frac{\pi}{16}\right) \\ &= 2330 \text{ LB} \end{aligned}$$

$$\begin{aligned} \text{INPUT PINION } F_{b_y} &= (190,000)(.5)(.111)\left(\frac{\pi}{16}\right) \\ &= 2070 \text{ LB} \end{aligned}$$

STATIC BEAM STRENGTHS - FAILURE LIMIT

$$E4340 S_{ult} = 230,000 \text{ psi} \quad (200,000 - 260,000 \text{ psi MIL HDBK 5})$$

$$3^{\text{rd}} \text{ STAGE PINION } F_{b_y} = 18430 \text{ LB}$$

$$2^{\text{nd}} \text{ STAGE PINION } F_{b_y} = 7515 \text{ LB}$$

$$1^{\text{st}} \text{ STAGE PINION } F_{b_y} = 2820 \text{ LB}$$

$$\text{INPUT PINION } F_{b_y} = 2510 \text{ LB}$$

FACTORS OF SAFETY

GEAR	ULTIMATE	LIMIT
3 rd STAGE PINION	1.3	1.6
2 nd STAGE PINION	2.1	2.6
1 st STAGE PINION	6.5	8.9
INPUT PINION	10.2	12.5

HOIST DRIVETRAIN LOADS AND STRESSES
UNDER MAXIMUM OPERATING LOAD
CONDITIONS

(19,500 lb CABLE LOAD AT
10 FPM CABLE SPEED)

$$\text{DRUM SPEED} = \frac{10 \text{ ft/min}}{4.71 \text{ ft/rev}} = 2.1 \text{ RPM}$$

GEAR SPEEDS (RPM)	SUN	RING	PLANET CAGE	PLANETS
3 rd STAGE	10	2.1	0	5.3
2 nd STAGE	165	2.1	10	38.9
1 st STAGE	1585	2.1	165	255
INPUT	9940			

GEAR TYPES - MODIFIED FELLOWS STUB TOOTH
GEAR PITCHES - 3rd STAGE 8/10
2nd STAGE 8/10
1st STAGE 16/21
INPUT 16/21

ALL 20° P.A.

PITCH-LINE VELOCITIES

3rd STAGE PINION = $(\pi(27/8)/12) \times 10 = 8.8 \text{ FPM}$
 2nd STAGE PINION = $(\pi(15/8)/12) \times 165 = 81 \text{ FPM}$
 1st STAGE PINION = $(\pi(20/16)/12) \times 1585 = 518.7 \text{ FPM}$
 INPUT PINION = $(\pi(15/16)/12) \times 9940 = 2440 \text{ FPM}$

TORQUES

$$\begin{aligned} \text{DRUM} &= (19500)(9) = 175500 \text{ IN-LB} \\ 3^{\text{rd}} \text{ STAGE PINION} &= (175500) / (5.778 \times 9) = 33750 \text{ IN-LB} \\ 2^{\text{nd}} \text{ STAGE PINION} &= (33750) / (9.6 \times 9) = 3910 \text{ IN-LB} \\ 1^{\text{st}} \text{ STAGE PINION} &= (3910) / (13.5 \times 9) = 320 \text{ IN-LB} \\ \text{INPUT PINION} &= (320) / (6.33 \times 98) = 50 \text{ IN-LB} \end{aligned}$$

APPLIED LOADS

$$\begin{aligned} 3^{\text{rd}} \text{ STAGE TEETH} &= (33750) / (4 \times 1.688 \times .75) = 6665 \text{ LB} \\ 2^{\text{nd}} \text{ STAGE TEETH} &= (3910) / (3 \times .938 \times .75) = 1855 \text{ LB} \\ 1^{\text{st}} \text{ STAGE TEETH} &= (320) / (3 \times .625 \times .75) = 230 \text{ LB} \\ \text{INPUT TEETH} &= (50) / (.938 \times .75) = 70 \text{ LB} \end{aligned}$$

$$\text{ALLOWABLE DYNAMIC LOADS} = F_b \times \frac{600}{600 + v}$$

$$3^{\text{rd}} \text{ STAGE} \quad F_{b_3} = 18430 \times \frac{600}{600 + 8.8} = 18160 \text{ LB}$$

$$2^{\text{nd}} \text{ STAGE} \quad F_{b_2} = 7515 \times \frac{600}{600 + 81} = 6621 \text{ LB}$$

$$1^{\text{st}} \text{ STAGE} \quad F_{b_1} = 2820 \times \frac{600}{600 + 518.7} = 1512 \text{ LB}$$

$$\text{INPUT} \quad F_{b_i} = 2510 \times \frac{600}{600 + 2440} = 495 \text{ LB}$$

FACTORS OF SAFETY (BASED ON DYNAMIC LOADS, PIV-18)

$$3^{\text{rd}} \text{ STAGE} = 18160 / 6704 = 2.7$$

$$2^{\text{nd}} \text{ STAGE} = 6621 / 2040 = 3.2$$

$$1^{\text{st}} \text{ STAGE} = 1512 / 560 = 2.7$$

$$\text{INPUT} = 495 / 490 = 1.01$$

STATIC BEAM STRESSES

$$S_b = \frac{-F_b}{b \left(\frac{Y}{Pd} \right)}$$

3rd STAGE

$$S_b = \frac{6665}{1.5 \left(\frac{\pi (.1367)}{8} \right)} = 83200 \text{ psi}$$

2nd STAGE

$$S_b = \frac{1855}{.75 \left(\frac{\pi (.1117)}{8} \right)} = 56740 \text{ psi}$$

1st STAGE

$$S_b = \frac{230}{.5 \left(\frac{\pi (.125)}{12} \right)} = 19525 \text{ psi}$$

INPUT

$$S_b = \frac{70}{.5 \left(\frac{\pi (.111)}{16} \right)} = 6425 \text{ psi}$$

DYNAMIC LOADS

ESTIMATED ERROR IN ACTION = .0005 in

$$C = .860$$

$$W_d = \frac{.05V(FC+W)}{.05V + \sqrt{FC+W}} + W_{\text{STATIC}}$$

3rd STAGE

$$FC+W = (1.5)(860) + 6665 = 7955$$

$$W_d = \frac{.05(8.8)(7955)}{.05(8.8) + \sqrt{7955}} + 6665 = 39 + 6665 = 6704 \text{ lb}$$

2nd STAGE

$$FC+W = (.75)(860) + 1855 = 2500$$

$$W_d = \frac{.05(81)(2500)}{.05(81) + \sqrt{2500}} + 1855 = 185 + 1855 = 2040 \text{ lb}$$

1st STAGE

$$FC+W = (.5)(860) + 230 = 660$$

$$W_d = \frac{.05(518.7)(660)}{.05(518.7) + \sqrt{660}} + 230 = 330 + 230 = 560$$

INPUT

$$FC+W = .5(860) + 70 = 500$$

$$W_d = \frac{.05(2440)(500)}{.05(2440) + \sqrt{500}} + 70 = 420 + 70 = 490 \text{ lb}$$

RATIO FACTORS

$$Q = \frac{2N_g}{N_p + N_g}$$

3rd STAGE

$$Q = \frac{2(129)}{27+129} = 1.65$$

1st STAGE

$$Q = \frac{2(250)}{20+250} = 1.85$$

2nd STAGE

$$Q = \frac{2(129)}{15+129} = 1.79$$

INPUT

$$Q = \frac{2(94)}{15+94} = 1.73$$

WEAR LOADS

$$W_w = DFKQ$$

$$D = P.D.$$

K = 575 BASED UPON BHN
450 FOR ALL GEARS,
20° HARDENED STL

3rd STAGE

$$W_w = (3.375)(1.5)(575)(1.65) = 4800 \text{ LB}$$

2nd STAGE

$$W_w = (1.875)(.75)(575)(1.79) = 1450 \text{ LB}$$

1st STAGE

$$W_w = (1.25)(.5)(575)(1.85) = 665 \text{ LB}$$

INPUT

$$W_w = (.938)(.5)(575)(1.73) = 465 \text{ LB}$$

BEARINGS

DRUM BEARINGS

DRUM WT = 78.85 LB
LIMIT TORQUE = 360,000 in lb
WORKING TORQUE = 175,500 in lb

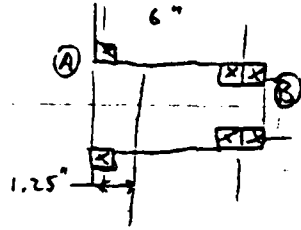

ASSUME WT IS EQUALLY
DISTRIBUTED BETWEEN
(A) and (B)

$$\text{LIMIT LOAD } F_L = \frac{360,000}{2(129/8)} + 78.85 = 11,240 \text{ LB}$$

$$\text{WORKING LOAD } F_W = \frac{175,500}{2(129/8)} + 78.85 = 5520 \text{ LB}$$

BEARING (A) CARRIES ITS MAXIMUM LOAD WHEN CABLE IS FULL LEFT

$$F_A = F \times \frac{6 - 1.25}{6} = .80 F \quad F_{L_A} = 8995 \text{ LB}$$

$$F_{W_A} = 4180 \text{ LB}$$

CAPACITY KF 160 AHO 25,500 STATIC, 9950 DYNAMIC

BEARING (B) (2) CARRIES FULL LOAD WHEN CABLE IS FULL RIGHT

CAPACITY KF 19400 LB STATIC, 9100 LB DYNAMIC
LOAD IS SHARED BY 2 BEARINGS $\therefore F_{L_B} = 5620 \text{ LB}$
 $F_{W_B} = 2760 \text{ LB}$

ALL OTHER DRIVE COMPONENT WTS ARE ASSUMED
NEGLECTIBLE

PLANETARY DRIVE

3rd STAGE

PINION

LOADS ARE BALANCED BETWEEN 4 PLANETS,
 \therefore NO LOAD

PLANETS

$$F_{L_P} = \frac{2F_L}{4} = 4620 \text{ LB}$$

$$F_L = \frac{62300}{2(27/8)} = 9230 \text{ LB}$$

$$F_{W_P} = \frac{33750}{2(27/8)} = 5000 \text{ LB}$$

$$F_{W_P} = \frac{2F_P}{4} = 2500 \text{ LB}$$

CAPACITY GB-248 4830 STATIC
3480 DYNAMIC

LOAD IS SHARED BY 2 BEARINGS,

$$\therefore F_{L_P} = 2310 \text{ LB}$$

$$F_{W_P} = 1250 \text{ LB}$$

2ND STAGE

PINION

LOADS ARE BALANCED BETWEEN 3 PLANETS
∴ NO LOAD

PLANETS

$$F_{LP} = \frac{2 F_L}{3}$$
$$= 1160 \text{ LB}$$

$$F_{WP} = \frac{2 F_W}{3}$$
$$= 700 \text{ LB}$$

$$F_L = \frac{6490}{2(15/8)} = 1735 \text{ LB}$$

$$F_W = \frac{3910}{2(15/8)} = 1045 \text{ LB}$$

CAPACITY GB 2412 = 8220 LB STATIC
5250 LB DYNAMIC

1ST STAGE

PINION - SEE INPUT

PLANETS

$$F_{LP} = \frac{2 F_L}{3}$$
$$= 130 \text{ LB}$$

$$F_{WP} = \frac{2 F_W}{3}$$
$$= 85 \text{ LB}$$

$$F_L = \frac{480}{2(20/16)} = 192 \text{ LB}$$

$$F_W = \frac{320}{2(20/16)} = 128 \text{ LB}$$

CAPACITY MRC 1907-S

980 LB DYNAMIC
@ 300 RPM

INPUT / 1ST STAGE PINION

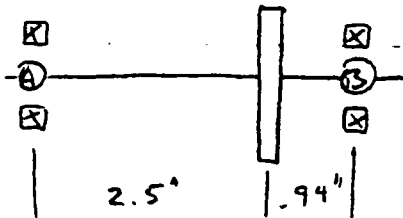

OUTPUT IS TO LEFT OF (A)
IS 1ST STAGE PLANET DRIVE
PINION ∴ NO LOAD PRODUCED

GEAR FORCES

$$TANGL = \frac{76}{2(15/16)} = 45 LB$$

$$SEPL = 45 \tan(20+3) = 19 LB$$

TOTAL RADIAL LOAD
(LIMIT)

$$TANGLW = \frac{50}{2(15/16)} = 30 LB$$

$$SEPLW = 30 \tan(20+3) = 13 LB$$

TOTAL RADIAL LOAD
(WORKING)

BEARING LOADS

(A)

$$45 \times \frac{.94}{2.5 + .94} = 12 LB$$

$$19 \times \frac{.94}{2.5 + .94} = 5 LB$$

$$\sqrt{12^2 + 5^2} = 13 LB$$

$$30 \times \frac{.94}{2.5 + .94} = 8 LB$$

$$13 \times \frac{.94}{2.5 + .94} = 4 LB$$

$$\sqrt{8^2 + 4^2} = 9 LB$$

(B)

$$45 \times \frac{2.5}{2.5 + .94} = 33 LB$$

$$19 \times \frac{2.5}{2.5 + .94} = 14 LB$$

$$\sqrt{33^2 + 14^2} = 36 LB$$

$$30 \times \frac{2.5}{2.5 + .94} = 22 LB$$

$$13 \times \frac{2.5}{2.5 + .94} = 9 LB$$

$$\sqrt{22^2 + 9^2} = 24 LB$$

CAPACITY (A) MRC 1907-S

540 LB DYNAMIC @ 2500 RPM

(B) MRC 1906-S

425 LB DYNAMIC @ 2500 RPM

INPUT PINION / SPLINE

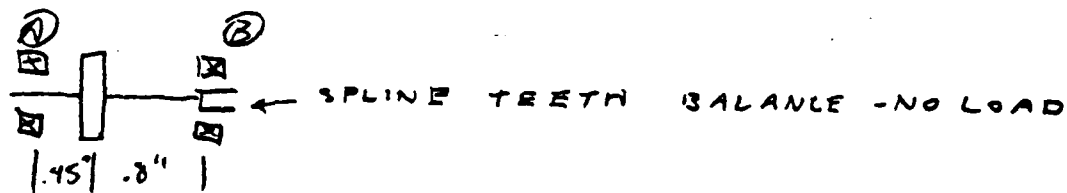

GEAR FORCES

TANG_L = 45 LB

SEP_L = 19 LB

TOTAL RADIAL LOAD (LIMIT)

TANG_w = 30 LB

SEP_w = 13 LB

BEARING LOADS

Ⓐ

$45 \times \frac{.8}{.45 + .8} = 29 \text{ LB}$

$19 \times \frac{.8}{.45 + .8} = 12 \text{ LB}$

$\sqrt{29^2 + 12^2} = 31 \text{ LB}$

$30 \times \frac{.8}{.45 + .8} = 19 \text{ LB}$

$13 \times \frac{.8}{.45 + .8} = 8 \text{ LB}$

Ⓑ

$45 \times \frac{.45}{.45 + .8} = 16 \text{ LB}$

$19 \times \frac{.45}{.45 + .8} = 7 \text{ LB}$

$\sqrt{16^2 + 7^2} = 18 \text{ LB}$

$30 \times \frac{.45}{.45 + .8} = 11 \text{ LB}$

$13 \times \frac{.45}{.45 + .8} = 5 \text{ LB}$

CAPACITY Ⓐ

MRC 100-KS 185 LB DYNAMIC @ 2500 RPM

Ⓑ

MRC 1905-S 345 LB DYNAMIC @ 2500 RPM

10

Book No. 578
Appendix V

A P P E N D I X V

MOTOR & BRAKE ASSEMBLY OUTLINE

(BL-3168-1)

This drawing shows the internal structure of the device. It is a schematic representation of the internal components, including the coil, the core, and the various electrical connections. The drawing is intended to provide a detailed view of the internal assembly for manufacturing and assembly purposes.

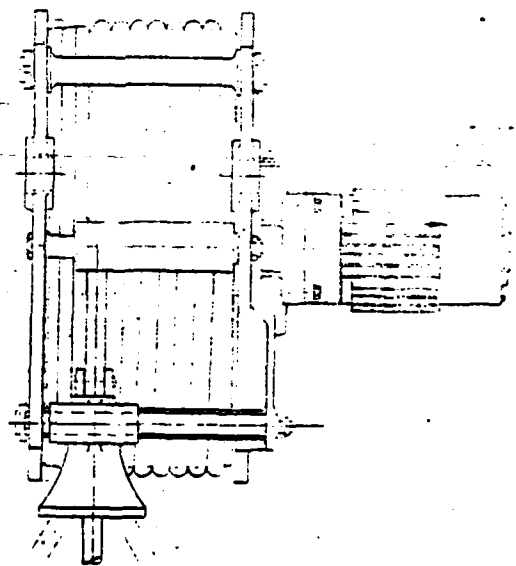

NOTES

1. **Core** - (See drawing) - (See drawing) - (See drawing)
2. **Coil** - (See drawing) - (See drawing) - (See drawing)
3. **Winding** - (See drawing) - (See drawing) - (See drawing)
4. **Terminal** - (See drawing) - (See drawing) - (See drawing)
5. **Support** - (See drawing) - (See drawing) - (See drawing)

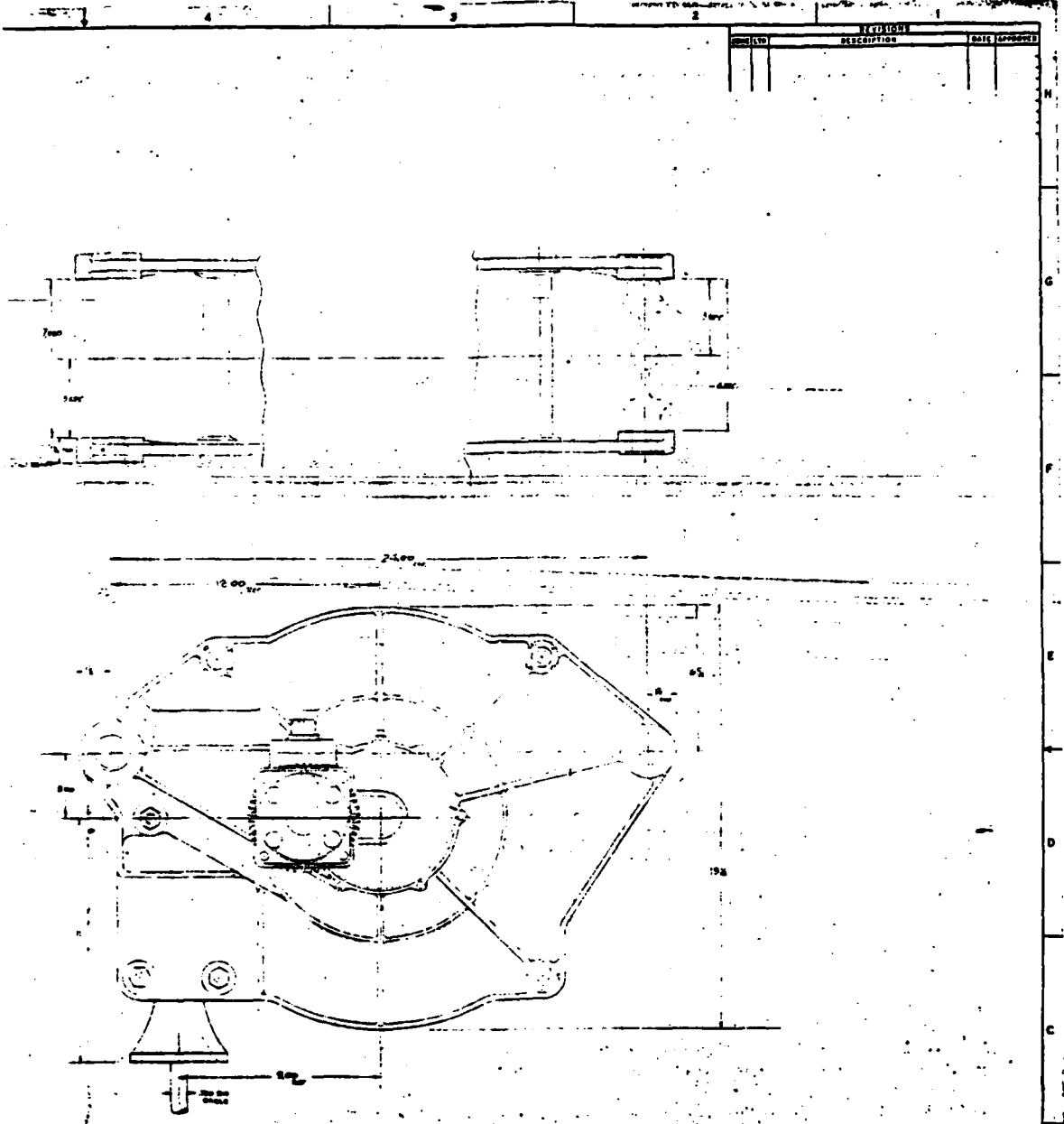

REV.	DESCRIPTION	DATE	APPROVED

BTD-263-648

ALL DIMENSIONS UNLESS OTHERWISE SPECIFIED ARE IN INCHES AND DECIMALS THEREOF. DIMENSIONS ARE TO BE TAKEN TO THE CENTER OF HOLES UNLESS OTHERWISE SPECIFIED. DIMENSIONS ARE TO BE TAKEN TO THE CENTER OF HOLES UNLESS OTHERWISE SPECIFIED.	DRAWN BY CHECKED BY DATE	BREXZ CORPORATION, INC. 1000 N. 10TH ST. FORT WORTH, TEXAS 76102

END

DATE
FILMED

9-80

DTIC