

AD-A088 210

WESTEC SERVICES INC SAN DIEGO CA
MEDICAL TREATMENT FACILITY WORKLOAD DOCUMENTATION GUIDE. (U)
APR 80 W T RASHUSSEN, H W HOLMERUD

F/6 6/5

N00123-77-D-0458

UNCLASSIFIED

NOSC-TD-357

NL

1 of 1
AD-A088 210

NOSC

END
DATE
FILMED:
9-80
DTIC

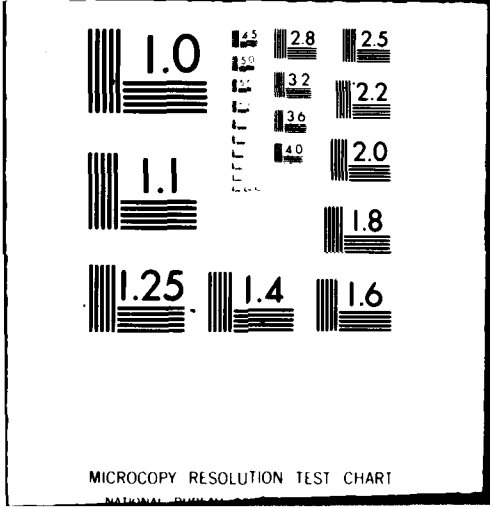

II (12) 1

NOSC

NOSC TD 357

NOSC TD 357

AD A088210

Technical Document 357

MEDICAL TREATMENT FACILITY WORKLOAD DOCUMENTATION GUIDE

WT Rasmussen and HW Holmerud
(NOSC)

JA Kuhlman
WESTEC Services, Inc.
N00123-77-D-0458

15 April 1980

Final Report: 1 September 1978 - 1 September 1979

Prepared for:
Naval Medical Data Services Center
Code 04

Approved for public release; distribution unlimited.

DTIC
AUG 25 1980

NAVAL OCEAN SYSTEMS CENTER
SAN DIEGO, CALIFORNIA 92152

A

DDC FILE COPY

80 8 22 041



NAVAL OCEAN SYSTEMS CENTER, SAN DIEGO, CA 92152

A N A C T I V I T Y O F T H E N A V A L M A T E R I A L C O M M A N D

SL GUILLE, CAPT, USN

Commander

HL BLOOD

Technical Director

ADMINISTRATIVE INFORMATION

This Technical Document reports on work performed under NOSC Work Unit CE12 between 1 September 1978 and 1 September 1979 for the Naval Medical Data Services Center, National Naval Medical Center, Code 04, Bethesda, MD 20014.

The methodologies presented in this document were, for the most part, developed and utilized to obtain patient and communications workload data at the Naval Regional Medical Center (NRMC), Portsmouth, VA, as pertaining to the Network Interface System (NIS). This document is intended only as an aid in determining what workload data to collect, possible sources for collecting the data, and methods of displaying the data. The exact data requirements will depend upon the specific medical facility and functional areas involved, and the system(s) for which the data is being collected. Further refinements or additions to the methodologies reported in this document are expected after the previously collected data has been used in simulation prediction models, and again following installation and testing of related systems.

The work presented in this report was prepared by WESTEC Services, Inc., San Diego, under contract N00123-77-D-0458, Task 7N49, and the Terminals and Control Systems Branch (NOSC, Code 8153). Principal investigators were J.A. Kuhlman (WESTEC Services, Inc.) and H.W. Holmerud (NOSC, Code 8153), under the direction of W.T. Rasmussen, Head, Biomedical Engineering Branch (NOSC, Code 8233).

Released by
J. Silva, Head
Man-System Interaction Division
NOSC, Code 823

Under authority of
J.H. Maynard, Head
Command Control-Electronic Warfare
System and Technology Department
NOSC, Code 82

UNCLASSIFIED

SECURITY CLASSIFICATION OF THIS PAGE (When Data Entered)

REPORT DOCUMENTATION PAGE		READ INSTRUCTIONS BEFORE COMPLETING FORM
1. REPORT NUMBER 13 NOSC/Technical Document 357 (TD 357)	2. GOVT ACCESSION NO. AD-A088210	3. RECIPIENT'S CATALOG NUMBER FI 1 1 1 1
4. TITLE (and Subtitle) MEDICAL TREATMENT FACILITY WORKLOAD DOCUMENTATION GUIDE		5. TYPE OF REPORT & PERIOD COVERED 1 September 1978 - 1 September 1979
7. AUTHOR(s) W.T. Rasmussen and HW Holmerud Naval Ocean Systems Center JA Kuhlman, WESTEC Services, Inc.		6. CONTRACT OR GRANT NUMBER(s) 14 1111 X 1
9. PERFORMING ORGANIZATION NAME AND ADDRESS Naval Ocean Systems Center San Diego, CA 92152		10. PROGRAM ELEMENT, PROJECT, TASK AREA & WORK UNIT NUMBERS CE12
11. CONTROLLING OFFICE NAME AND ADDRESS Naval Medical Data Services Center Code 04 Bethesda, MD 20014 1341		12. REPORT DATE 15 April 1980
14. MONITORING AGENCY NAME & ADDRESS (if different from Controlling Office) 10 12 1111		13. NUMBER OF PAGES 46
		15. SECURITY CLASS. (of this report) Unclassified
		15a. DECLASSIFICATION/DOWNGRADING SCHEDULE
16. DISTRIBUTION STATEMENT (of this Report) Approved for public release; distribution unlimited. 10 V. I. P. H. V. H. 1111 J. A. K. 1111		
17. DISTRIBUTION STATEMENT (of the abstract entered in Block 20, if different from Report)		
18. SUPPLEMENTARY NOTES		
19. KEY WORDS (Continue on reverse side if necessary and identify by block number) Computer Communications Network Medical Computer Applications Hospital Information Systems Patient Workload Profiles Data Management		
20. ABSTRACT (Continue on reverse side if necessary and identify by block number) Methodologies suitable for collection of patient, communications, and facility profile data to be used in determining the appropriate computer network and size for a given health care facility are presented. Study was directed toward capture of information needed for site characterization prior to implementation of computerized data handling system networks for military hospitals.		

DD FORM 1 JAN 73 1473

EDITION OF 1 NOV 65 IS OBSOLETE
S/N 0102-LF-014-6601

UNCLASSIFIED

SECURITY CLASSIFICATION OF THIS PAGE (When Data Entered)

2 1111 5

UNCLASSIFIED

SECURITY CLASSIFICATION OF THIS PAGE (When Data Entered)

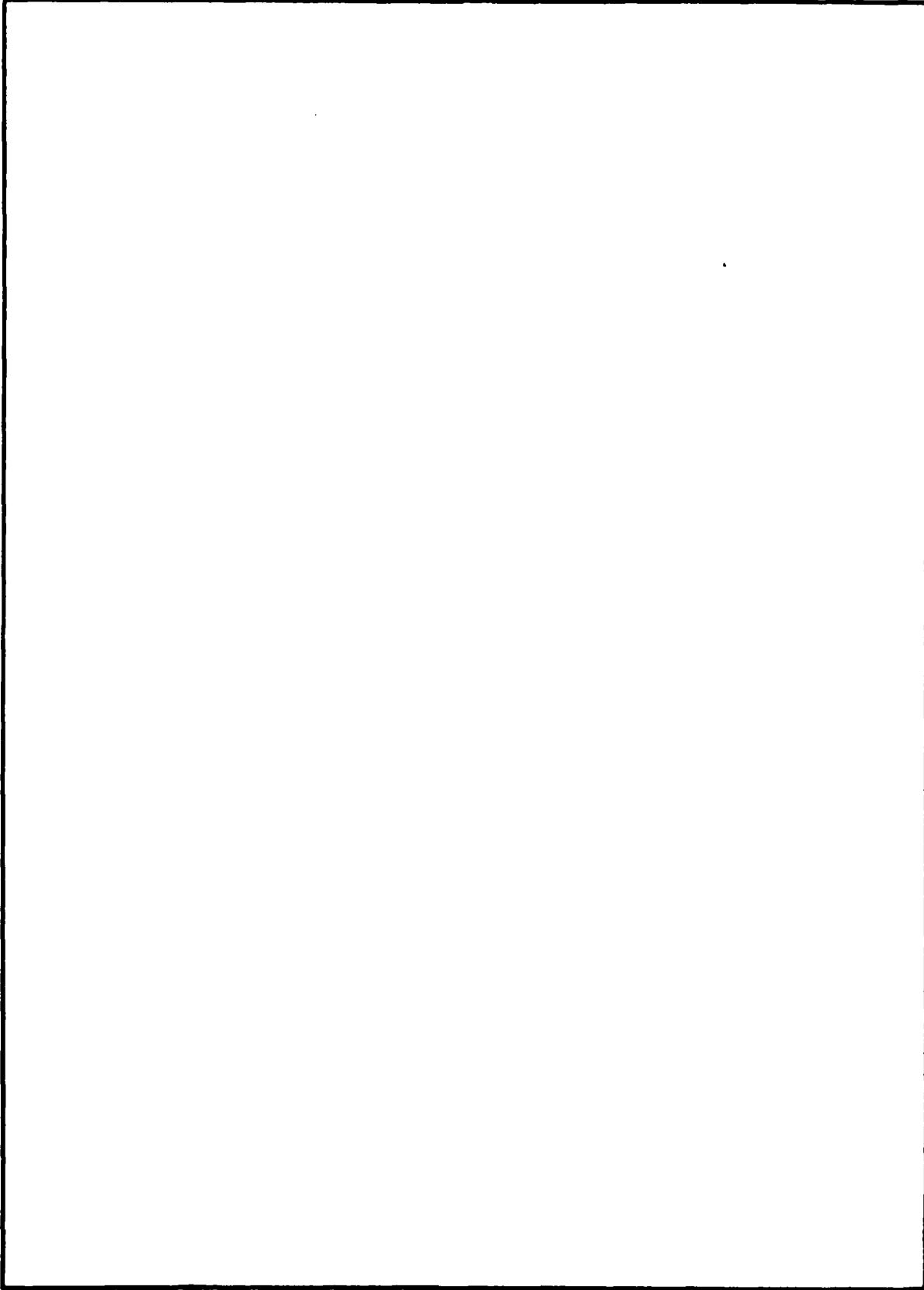

UNCLASSIFIED

SECURITY CLASSIFICATION OF THIS PAGE(When Data Entered)

TABLE OF CONTENTS

<u>Section</u>	<u>Title</u>	<u>Page</u>
1	INTRODUCTION	1
1.0	Background and Purpose	1
1.1	An Approach to Computers and Medicine	1
1.2	Computer Network Concept	2
1.3	Data Collection Overview	2
2	DATA REQUIREMENTS	5
2.0	Scope	5
2.1	Site Patient Workload	5
2.2	Site Communications Workload	8
2.3	Site Facility Profile	9
2.4	Data Collection Checklist	10
3	DATA COLLECTION METHODOLOGY	15
3.1	Administrative Notification	15
3.2	Functional Area Contacts	15
3.3	Data Collection Methods	15
4	DATA ORGANIZATION	23
4.1	Statistical Parameters	23
4.2	Site and Function Statistical Relationships	30

Requested For	
Name	<input checked="" type="checkbox"/>
DOB	<input type="checkbox"/>
Unit	<input type="checkbox"/>
Justification	<input type="checkbox"/>
By _____	
Date _____	
A	

TABLE OF CONTENTS (Continued)

<u>Section</u>	<u>Title</u>	<u>Page</u>
4.3	Interfunctional Statistical Relationships	30
4.4	Narrative Presentation	30
5	METHODS COMPARISON	33
5.0	Methodology Selection	33
5.1	Interviews	33
5.2	Records	33
5.3	Questionnaires	35
5.4	Equipment Counts	35
5.5	Time Stamps	35
6	TECHNICAL AND MANAGEMENT OVERVIEW	37
6.0	Network Interface System Implementation	37
6.1	Communications Network Analysis	37
6.2	Network Interface System Requirements	40
7	REFERENCES	41
APPENDICES		
<u>Appendix</u>	<u>Title</u>	
A	NIS SITE CHARACTERIZATION DATA COLLECTION CHECKLIST	42

TABLE OF CONTENTS (Continued)

LIST OF FIGURES

<u>Figure</u>	<u>Title</u>	<u>Page</u>
1-1	Network Interface System Communications Configuration	3
2-1	Sample NIS Site Characterization Data Collection Checklist	11
3-1	Sample Patient Information Questionnaire — Alternate 1	19
3-2	Sample Patient Information Questionnaire — Alternate 2	20
4-1	Sample Data Presentation Format — Monthly Values, Table	24
4-2	Sample Data Presentation Format — Monthly Values, Graph	25
4-3	Sample Data Presentation Format — Daily Values, Table	26
4-4	Sample Data Presentation Format — Daily Values, Graph	27
4-5	Sample Data Presentation Format — Percent of Total, Table	28
4-6	Sample Data Presentation Format — Percent of Total, Graph	29
6-1	Network Interface System Requisite Capabilities	38
6-2	NIS Represented as a "STAR" Network	39

LIST OF TABLES

<u>Table</u>	<u>Title</u>	<u>Page</u>
5-1	Methods Comparison Summary	34

SECTION 1

INTRODUCTION

1.0 BACKGROUND AND PURPOSE

This document has been prepared to support the continuing development of automated data communications within the military hospital environment. Sponsored by the Tri-Services Medical Information System (TRIMIS) Program Office (TPO), this study is directed toward the capture of information needed for site characterization prior to the implementation of a computerized data handling system. Presented in this report are methodologies suitable for collection of the patient, communications, and facility profile data to be used in determining the appropriate computer network and size for a given health care facility. The precise data required to configure and "size" the computer network will depend on the specific medical facility and functional areas involved, as well as system functional implementation objectives.

The information presented here is based upon the experience gained during a site characterization study at the Naval Regional Medical Center (NRMC), Portsmouth VA. Data collection at NRMC Portsmouth focused on the four functional areas selected for data automation at that site: Pharmacy, Laboratory, Radiology, and Patient Appointment Scheduling (PAS). In addition, information was collected from other areas which impact the four functions under study (for instance, Emergency Room referrals to the Radiology Department). Although other sites will necessarily present different challenges in the collection of site characterization data, it is intended that the types of methods discussed in this document be applicable to other medical treatment facilities (MTFs) as well.

1.1 AN APPROACH TO COMPUTERS AND MEDICINE

Today's medical environment, with its increasingly complex technological capabilities, generates greater masses of information than ever before. This information "explosion" benefits patients, health care providers, and administrators alike -- the more data at one's disposal, the better one's ability to make sound decisions, saving time, money, and lives. However, problems arise in the area of data management: what good is all this information if you can't find what you're looking for when you need it? To handle this situation, computers have entered the health care field.

One computer might manage information for the Patient Appointment Scheduling area, keeping track of available appointment slots, assisting with reschedules and cancellations, offering medical records support, etc. Another computer might provide information management in the Radiology Department, offering support in the areas of registration, scheduling, film file control, diagnostic reporting, and statistical administrative accounting. The applications of automated data processing in the medical environment continue to expand.

1.2 COMPUTER NETWORK CONCEPT

Once these computers are installed and put into action, another difficulty arises: that of managing these separate computer systems so that they work in conjunction with and communicate with one another. This is achieved through the implementation of a computer NETWORK, or overall communications traffic system. This communications network is designed to coordinate and regulate computer message traffic that must be sent from one computer system to another computer system, or from a user to the computer, within the MTF. At the heart of the communications network is another computer system, commonly referred to as the Network Interface System (NIS). The NIS accepts messages from users in the hospital and routes them to the appropriate destination for processing. As an example, the scheduling clerk in the Internal Medicine clinic desires to establish an appointment for a patient in that clinic. The NIS will accept this appointment request when it is entered on a terminal in the Internal Medicine clinic. Then the NIS will forward the request to PAS. Once PAS has established a valid time for the appointment, the NIS passes this information back to the requester for verification and confirmation. In another example, a doctor in the Intensive Care ward needs the results of a patient's Laboratory tests. This message travels from the ward to the NIS, which passes the message on to the Laboratory system. There, the test information is retrieved, and the results are forwarded to the doctor, again by way of the NIS. In these examples, the NIS communicates directly with the functional entities (e.g., the Laboratory system, the physician on the ward, the scheduling clerk at the clinic, the PAS system, etc.) within an MTF, and aids in the decentralized collection, centralized storage, and distribution of patient identification and clinical data among the functional entities.

The NIS will provide communications interfaces for each of the functional systems with which it interacts, as illustrated in the typical communications configuration of Figure 1-1. Designed to accommodate the data handling requirements presented at Portsmouth NRMC, the configuration shown in Figure 1-1 provides for direct communications links between the NIS and the four functional areas under consideration at Portsmouth, i.e. PAS, Radiology, Laboratory, and Pharmacy. In addition, NIS links are provided for OTHER areas within the MTF which may also require direct communications interfaces, as in the case of the Orthopedics Department requesting a patient's Radiology report. The NIS will provide connections for these communications and more.

1.3 DATA COLLECTION OVERVIEW

Sufficient data must be collected at each MTF before an NIS can be developed and implemented. This information is required in order to "size" the system to the specific data communication requirements at any given site. If sized too small, the NIS will be unable to handle the communication inputs and outputs; if sized beyond reasonable growth capabilities, excess hardware expenses (wires, cables, etc.) will result in costly inefficiency and waste. It should be stressed that implementation of new automated systems will, in general, result in an increase of data requests among users. Although it is necessary to use existing hospital records to acquire the basic patient and communication workload profiles, a thorough analysis of planned changes in

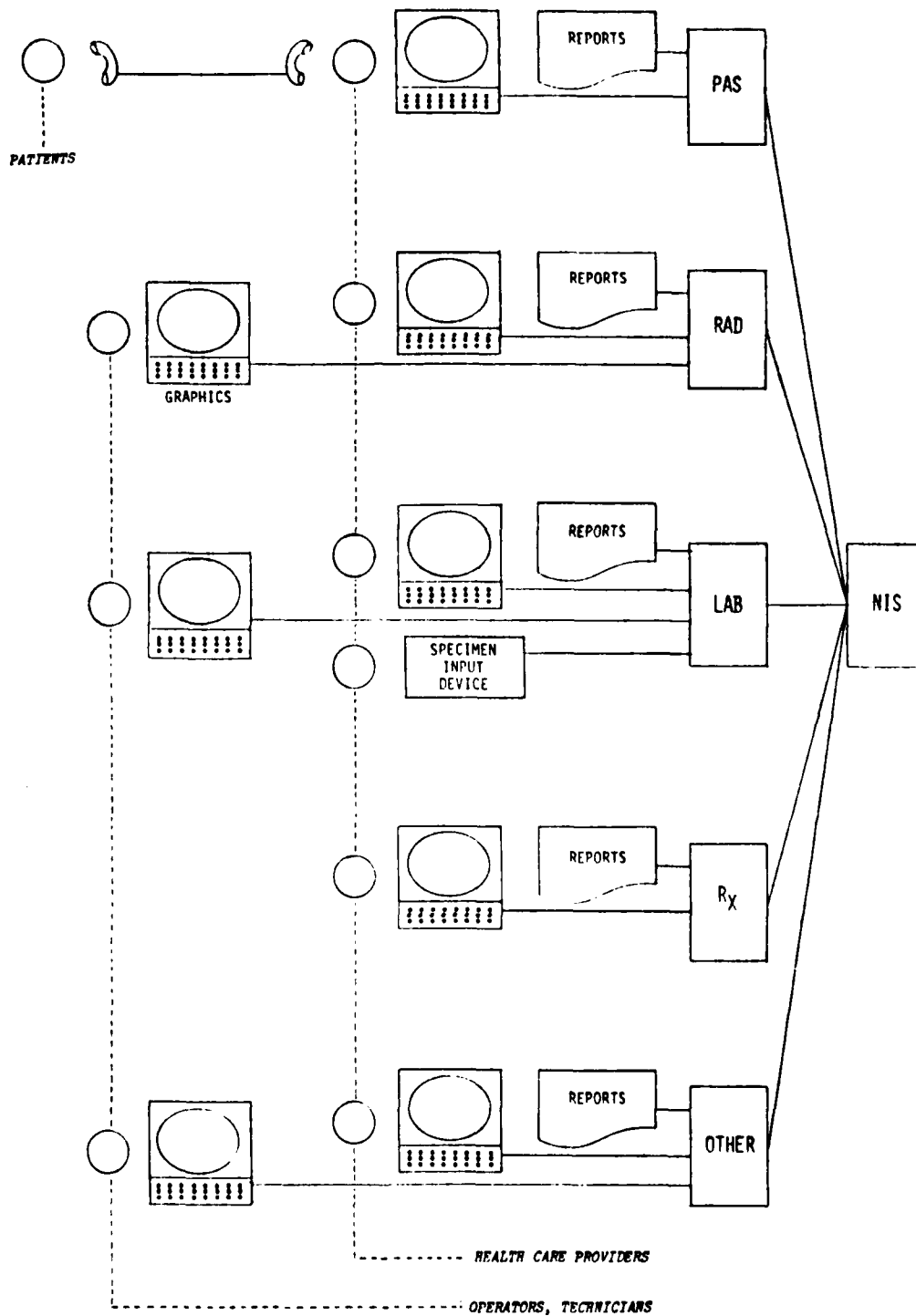

Figure 1-1. Network Interface System Communications Configuration

operations or anticipated changes in workloads due to the system implementation should be presented.

This document is intended as a guidebook for determining the site specific characteristics of an MTF needed prior to development of a Network Interface System. Section 2 outlines the types of patient, communications, and facility data needed to characterize a given MTF; Section 3 explains how to go about collecting the required data. Data organization and reduction are addressed in Section 4. Section 5 provides a comparison of the various methodologies available as data collection tools, while Section 6 offers technical management and communications overviews. References are provided in the final section.

SECTION 2

DATA REQUIREMENTS

2.0 SCOPE

Data collection for the NIS site characterization study will be required on two separate levels: information pertaining to the MTF as a whole (e.g., total number of inpatient visits for the MTF per year); and data related to the specific functional area under study (e.g., total inpatient narcotic prescriptions per year). In addition, data related to outside workload referrals must be included in this effort, i.e. x-ray exposures referred to commercial firms for interpretation.

Site characterization data are further subdivided into three separate areas: site patient workload, site communications workload, and site facilities profile. The data collection requirements for each of these categories are outlined in the following pages.

2.1 SITE PATIENT WORKLOAD

Site patient workload refers to the actual health care services provided by the MTF, and includes such elements as clinic visits, tests, appointments, prescriptions, referrals, etc. These patient transactions directly affect the communications environment and the NIS through their INPUTS and OUTPUTS. Regardless of the area under consideration, a certain number of demands are fed into the communications system (input), and resulting products are fed back from that system (output). Examples include: Laboratory - specimens (input), test results (output); Pharmacy - prescriptions (input), pharmaceutical units (output); Ophthalmology - appointments (input), patient visits (output). Communication inputs and outputs may take a variety of forms, from telephone calls to x-ray exposures; the common denominator involves patient data and material transactions. Recognition of these health care transactions and their component inputs and outputs is the focus of this site patient workload analysis.

2.1.1 Facility Overview

The manner in which a facility fits into the overall health care network will impact the data collection effort. Some facilities are maintained as branch outpatient clinics, accountable to a hospital or regional medical system; some operate as full-service hospitals within a regional jurisdiction, while others operate as regional medical centers.

These organizational differences will not only affect the types of services offered and patients accommodated, but the communication transactions as well. For example, branch clinics may refer a number of Laboratory specimens to a larger facility for analysis, creating additional complexities in the communications environment: input of the sample at the clinic results in output to the hospital, further resulting in hospital input, processing, and output to the clinic; there, it is received (input) and made available as output to the health care provider or patient. Obstetrics might provide another example of branch and hospital interactions, whereby a patient

may receive prenatal care at a branch facility, undergo labor and delivery at a regional medical center, and return to the branch clinic for postnatal care. Such input/output transactions should be counted in the facility-wide volume analysis of a communications system.

Prior to collecting any data, objectives and initial operating characteristics of the system(s) under study should be clearly delineated in order to determine what data are actually needed for the study. This will help simplify the data collection effort, and help reduce eventual user misunderstandings of the final system capabilities. Further, definitions of the data to be collected should be clearly stated to avoid ambiguities; for example, one Laboratory test may produce 12 individual test reports — it must be determined which number is available for data collection and which is meaningful in terms of the system requirements.

The overview of a medical facility also includes such inputs as the catchment (potential) population of the area to be served and the number of available inpatient beds; corresponding outputs include actual number of patient visits and average length of an inpatient stay. From these and other facility parameters, it may be projected that n Emergency Room patients can be expected each month from a total population of N , or that each outpatient visit may generate x Laboratory tests. These facility-wide data can then be incorporated into NIS planning.

2.1.2 Functional Areas

Volume analysis of patient workload inputs and outputs must also be performed at the functional level, i.e. Radiology, Physical Therapy, or Urology. The specific function being performed has no significance here except for the way in which its inputs and outputs impact the overall communications network. For example, inputs to PAS may include appointment phone call requests from patients, new and rescheduled appointment requests from health care providers, Laboratory prep requests from clinics, and CHAMPUS status requests; regardless of the way in which these inputs are processed, they generate new and rescheduled appointments, Laboratory prep instructions, and CHAMPUS benefit responses as outputs. Each department or functional area may be considered a separate entity, with no note given to its internal operations except for its data and material transactions with other functional areas.

2.1.3 Outside Referrals

Although the bulk of the patient workload communications to be identified will occur "in-house" or within a limited regional jurisdiction, there may occur cases in which the facility must refer certain procedures to commercial service industries. Complex Laboratory studies are often handled in this manner; even routine procedures may be subject to outside referral under heavy patient workload conditions. The double input/output communication requirements of such operations must also be considered in a patient workload study.

2.1.4 Data Collection Elements

Following are several elements which must be considered in the NIS patient workload analysis:

- **Inpatient/Outpatient Workloads**

If an MTF is equipped to handle both inpatients and outpatients, separate input/output counts must be maintained for each, since separate data handling and workload requirements usually occur due to the nature of the visit. Generally, outpatient visits may outnumber inpatient visits by ten to one, yet inpatient Laboratory tests may outnumber total outpatient tests because persons confined to a hospital are generally in need of more intense treatment. For example, at the Portsmouth Hospital between January 1977 and July 1978, there was a monthly average of 35,426 outpatient visits and 4,090 inpatient visits; however, while the average monthly Laboratory tests numbered 187,096 for outpatients (5.28 per visit), an average of 198,140 were recorded for inpatients (48.44 per visit). Similarly, inpatient Cardiology visits may be more intense and time-consuming (with greater data generation resulting) than an equal number of outpatient Cardiology visits. If both types of patients are treated at an MTF, each should be accounted for separately.

- **Past, Present, and Future**

It is important that site patient workload data be gathered over a long enough period of time to establish trends and to ensure that the resulting statistics will produce meaningful input/output parameters. Historical information should include data encompassing at least two years, or even more if possible. Present patient workload data can be inferred from the recent past, while future patient workloads may be deduced from past trends, area population projections, and educated guesses from administrative sources. Also, any planned or anticipated operational changes which might affect the patient workload data must be taken into consideration.

- **Data Time Frame**

Which patient workload counts should be examined: yearly, seasonal, monthly, weekly, daily, or hourly? The more information, the better; however, time and money may limit the scope of the data collection effort. If this is the case, the rule to follow is one of consistency. Monthly and daily counts were obtained throughout in the Portsmouth NRM study, with favorable results; yearly, seasonal, and weekly variations can then be analyzed from these monthly and daily data. Input/output counts by hour, when available, are also useful. Regardless of the time frame employed, it is important that counts be consistent for each of the areas under study: monthly counts should be related to other monthly statistics, and daily figures compared with daily. Be consistent!

- **Record Files**

The number of active and inactive patient records or files maintained by an MTF or functional area will also impact the patient workload. Information to be collected includes: peak number of records on hand; minimum number of records on

hand; average number of records on hand; average number of records transferred; and file archival and retirement processes.

- Staffing Profile

The number of officer, enlisted, and civilian personnel assigned to an MTF or functional area will have a bearing on the communications network. The number of billets allotted and the number of personnel actually on board should also be explored.

- Functional Interrelationships

This criterion identifies the areas which interact most directly with one another. While the relationship between Obstetrics and Radiology is largely one of avoidance, Emergency Room and Radiology contact may be an hourly phenomenon. Once these relationships are identified, their input/output counts may be determined and presented in statistical form, i.e. $x\%$ of all Radiology patients are referred from the Emergency Room, or the Emergency Room refers $y\%$ of its patients to Radiology. Similarly, it may be determined that $z\%$ of all Rheumatology patients obtained prior appointments, while the remainder (100% minus $z\%$) received treatment on a walk-in basis.

- Qualitative Profile

Each medical treatment facility offers a unique set of demographic, geographic and political patterns and trends which might also be considered in a communications survey. Ski season, for instance, might contribute to peak Radiology workloads at a facility near the Sierras. Or state regulations might require complete physical exams for children prior to the beginning of a school year, contributing to an August rush on Laboratory resources. The trend in another area might be toward a growing population of retirees or military reservists, each adding specialized impacts to a data communications environment. Identification of such qualitative local information will give added direction to the capture of quantitative site characterization data.

2.2 SITE COMMUNICATIONS WORKLOAD

The second subject for analysis in the NIS site characterization effort involves site communications workload. Within this area, data collection will focus on the transmission and receipt of hospital communications within four separate communication modes: record, voice, data, and messenger mail. Record communications, such as those prepared by the Naval Message Service, must be examined for internal distribution as well as transmission and receipt. Similarly, the voice communications analysis should encompass intrafacility and interfacility communication transactions, as well as incoming and outgoing calls. Data communications and messenger mail services will also be explored for their mutual impacts on clinical and administrative information and materials.

2.2.1 Record Communications

Under normal circumstances, record communications are not transferred directly from the Naval Telecommunications Service to a specialized data communications system (such as the one to be supported by the NIS). However, selected message traffic may be introduced into a data communications system that incorporates "annunciator" displays of the kind used to announce airline arrivals and departures at airports. Therefore, the development of administrative procedures and record parameters must be accomplished before this use of the NIS is practicable. For this reason, the data collection effort should be directed toward a record communications overview, pending selection of more specific record types.

2.2.2 Voice Communications

Both existing and planned capacities of site voice communications systems must be identified in this analysis. Circuits and trunk lines must be counted, and grades of service recorded. Counts must also be provided for the various voice communications instruments (telephones, etc.), transfer sets and systems, PBXs, and other equipment types. Special features of the voice communications environment, such as emergency numbers, telecopiers, or ECG monitoring stations, should also be included in this site characterization effort.

Existing equipment closets and cabling conduits must be identified as part of the voice communications analysis. The preferable method for establishing these locations is through the use of existing floor plans; however, since these drawings are usually somewhat dated and do not reflect current conditions, it is advisable to inspect the closets and conduits in person. Available expansion capacity can then be determined from these individual examinations.

2.2.3 Data Communications

Existing data communications systems that are slated for incorporation into the Network Interface System should be completely identified for the purposes of this analysis. This identification should not only include hardware and installation information, but software documentation as well. To the greatest extent possible, plans for future data communications systems should be outlined in this report.

2.2.4 Messenger Mail Services

Qualitative and quantitative analyses should also be performed to characterize existing internal messenger mail workloads. From the results of this effort, it may be determined that x% of the site communications now carried by hand may be transmitted by future data communications facilities. In some cases, due to the very nature of the data communications system design, some documents or reports may be eliminated.

2.3 SITE FACILITY PROFILE

The final area of consideration in the NIS site characterization task involves the physical facility capabilities of the MTF. The workable information requirements of this effort include:

- Power Availability (Normal/Emergency)
- Air Conditioning Rating (BTU/TON/CFM)
- Installed ADP Systems
- Fire Protection Systems
- Security Zones and Systems
- Floor Plans/Room Numbers
- Access Routes
- Preliminary Installation Planning
- Cable/Tray Capacity

Additional parameters may also be drawn, depending upon the facility being surveyed and the unique characteristics involved.

An on-site inspection of all spaces to be impacted by NIS implementation is required initially. During this inspection phase, a rough outline of each space and a listing of major equipments and/or equipment configurations must be constructed. Interviews with staff personnel should verify the preliminary facility findings. Next, efforts must be directed toward locating current blueprints for comparison purposes; these may be obtained from the Public Works Office or Civil Engineering Department. Physical discrepancies should then be noted and appropriate personal contacts made in order to resolve areas of confusion. Then, based upon preliminary findings, analysis, and personal contacts, facility spaces should be revisited to finalize on-site findings for NIS documentation purposes.

2.4 DATA COLLECTION CHECKLIST

Figure 2-1 provides an example of an NIS Site Characterization Data Collection Checklist. This checklist has been designed to insure completeness in the data collection effort, and provides an overview of the types of data to be included in the study. On the completed sample checklist, "X" indicates that data has been collected for the time period and area shown, "-" indicates no data collection, and "NA" indicates that the category is not applicable to the MTF under study. Where the collected data is based upon administrative estimates rather than substantive values, "est." is entered in the appropriate column. Other counts (year, hour, etc.) are indicated by type. Points of contact established in the data collection effort complete the checklist, providing easy reference for any follow-up information required. Again, although the types of data available will necessarily vary according to the individual characteristics of the MTF under study, certain parameters will hold constant, e.g., patient input/output workloads, power availability, telephone line expansion potential, etc. For the data collectors' use, a blank copy of Figure 2-1 is included in Appendix A at the end of this document.

NIS SITE CHARACTERIZATION
DATA COLLECTION CHECKLIST

Facility TRIMIS General Hospital

Dates 10-21 March 1980

PATIENT WORKLOAD

	INPUTS			OUTPUTS		
	Units/ Month	Units/ Day	Others (specify)	Units/ Month	Units/ Day	Others (specify)
Total Facility Visits	X	-	year	X	-	-
Inpatients (IP)	X	X	year	X	X	-
Outpatients (OP)	X	-	year	X	-	-
Catchment Population	-	-	year	-	-	-
Central Appointments	-	-	hour	X	X	hour
Laboratory IP	est.	est.	est.	X	-	-
Laboratory OP	est.	est.	est.	X	-	-
Radiology IP	X	X	-	X	X	-
Radiology OP	X	X	-	X	X	-
Pharmacy IP	X	X	-	X	X	-
Pharmacy OP	X	X	-	X	X	-
Clinics:						
Cardiology IP	X	-	-	X	-	-
Cardiology OP	X	-	-	X	-	-
Dermatology IP	NA	NA	NA	NA	NA	NA
Dermatology OP	X	-	-	X	-	-
Emergency Room	X	X	-	X	X	-
Gastroenterology IP	X	-	-	X	-	-
Gastroenterology OP	X	-	-	X	-	-
General Medicine IP	X	est.	-	X	est.	-
General Medicine OP	X	est.	-	X	est.	-
Gynecology IP	X	X	-	X	X	-
Gynecology OP	X	X	-	X	X	-
Immunization IP	NA	NA	NA	NA	NA	NA
Immunization OP	X	-	-	X	-	-

Figure 2-1. Sample NIS Site Characterization
Data Collection Checklist

PATIENT WORKLOAD

	INPUTS			OUTPUTS		
	Units/ Month	Units/ Day	Others (specify)	Units/ Month	Units/ Day	Others (specify)
Military Sick Call	X	X	-	X	X	-
Obstetrics IP	X	X	-	X	X	-
Obstetrics OP	X	X	-	X	X	-
Ophthalmology IP	NA	NA	NA	NA	NA	NA
Ophthalmology OP	X	-	-	X	-	-
Orthopedics IP	X	-	-	X	-	-
Orthopedics OP	X	est.	-	X	est.	-
Pediatrics IP	X	-	-	X	-	-
Pediatrics OP	X	X	-	X	-	-
Physical Exam	X	X	hour	X	X	hour
Physical Therapy IP	X	-	-	X	-	-
Physical Therapy OP	X	-	-	X	-	-
Proctology IP	X	-	-	X	-	-
Proctology OP	X	-	-	X	-	-
Psychiatry IP	NA	NA	NA	NA	NA	NA
Psychiatry OP	X	-	-	X	-	-
Screening Clinic	X	X	-	X	X	-
Urology IP	X	-	-	X	-	-
Urology OP	X	-	-	X	-	-
Other Clinics:						
Plastic Surg. IP	X	-	-	X	-	-
Plastic Surg. OP	X	-	-	X	-	-
Rheumatology IP	X	-	-	X	-	-
Rheumatology OP	X	-	-	X	-	-
_____ IP						
_____ OP						
_____ IP						
_____ OP						

(Use additional sheets if necessary)

COMMUNICATIONS WORKLOAD

- X Voice Systems
- X • Number of Lines
- X • Number of Telephone Instruments
- X • Grades of Service
- X • Expansion Potential
- X Digital Systems
- X Record Communications Systems (i.e. Naval Message Service)

FACILITY PROFILE

- X Power Availability (Normal/Emergency)
- X Air Conditioning Rating (BTU/TON/CFM)
- X Installed ADP Systems
- X Fire Protection Systems
- X Floor Plans/Room Numbers
- X Access Routes
- X Preliminary Installation Planning
- X Cable/Tray Capacity

POINTS OF CONTACT

<u>Department</u>	<u>Name</u>	<u>Telephone</u>
<u>Patient Affairs</u>	<u>LCDR D.R. Owen</u>	<u>X 6107</u>
<u>IP Administration</u>	<u>LT B. Tait</u>	<u>X 6352</u>
<u>OP Administration</u>	<u>Ms. A.W. Stichka</u>	<u>X 6214</u>
<u>PAS</u>	<u>LCDR R. Wallace</u>	<u>X 6202</u>
<u>Laboratory</u>	<u>CAPT D.K. Kramer</u>	<u>X 6117</u>
<u>Radiology</u>	<u>CAPT E.W. Hutzelman</u>	<u>X 6312</u>
<u>Pharmacy</u>	<u>CDR C.I. Colwell</u>	<u>X 6266</u>
<u>Data Processing</u>	<u>Mr. M.E. Veigtritter</u>	<u>X 6193</u>
<u>Civil Engineering</u>	<u>CDR P. Byrd</u>	<u>X 6300</u>
<u>Public Works</u>	<u>LT J.B. Mills</u>	<u>X 6245</u>
<u> </u>	<u> </u>	<u> </u>

At this point, it is suggested that the reader review the concepts of patient workload inputs and outputs as they relate to the Network Interface System. Within the network, data and material transactions appear as SYSTEM inputs and outputs only when they impact areas outside the realm of internal functional operations. For NIS site characterization purposes, it is not necessary to cite numbers of foot x-rays, chest x-rays, hand x-rays, etc., since data handling requirements are the same for all types of x-rays; rather, Radiology counts should indicate **x** total x-ray exposures, **y** total x-ray patients, or **z** total x-ray studies. Other Radiology procedures, such as fluoroscopies, should also receive specific mention in a survey of Radiology inputs and outputs, but the specific types of fluoroscopic examination are not relevant to a systems input/output analysis. Other data and material transactions which may impact the NIS include: entries in a patient's medical record; queries from one clinic to another, or from a clinic to the Pharmacy or Laboratory; responses to such queries; outside Laboratory referrals, etc.

SECTION 3

DATA COLLECTION METHODOLOGY

3.1 ADMINISTRATIVE NOTIFICATION

It is essential that MTF administrators be notified well in advance of the actual NIS data collection effort. At this time (at least two weeks prior to the beginning of data collection), the data collector should present a tentative data collection plan. This advance notification and scheduling should ease the data collection process in several ways: by formalizing objectives in the minds of administrators, functional area contacts, and the data collector(s); by readying data sources (e.g., log books, internal reports) for the collection of data; by uncovering suggestions and new approaches from MTF internal sources; and by gaining the cooperation of data collection contacts.

Once an administrative point of contact has been designated, the data collection effort should be coordinated through the aid of this person. The administrative coordinator may be able to: provide an overview of facility operations and organization; assist in obtaining contact points within the functional areas; offer leads as to data availability; and provide assistance in the follow-up of any long lead-time data items (i.e. questionnaire returns). An on-site Data Processing Service staff member might provide this critical link.

3.2 FUNCTIONAL AREA CONTACTS

Within each functional area, primary contact is required with the administrative officer, e.g. the Chief of Pharmacy Services. Through this contact, one may gain access to the specific records, charts, machines, and personnel from which the patient workload parameters may be drawn. Record reproduction (xerox) requirements may also be handled through this office.

Communication workloads and facilities profiles may be obtained through the Public Works Office or the Civil Engineering Department. Through these contacts, one may gain access to current and planned capabilities and traffic throughout the MTF. These data may also be supplemented by on-site examination of the specific functional area under study. Again, these personal contacts are to be obtained through the MTF administrative coordinator for the NIS data collection effort.

3.3 DATA COLLECTION METHODS

The means of data collection available at a given site or for a given functional area will vary according to the individual capabilities of that site and function. Additional constraints (time and money, in particular) may also dictate the actual approach to be employed.

The following paragraphs will illustrate many of the data collection techniques available to the site surveyor, using data collection at a sample MTF Pharmacy as an

example. These methods are also applicable to data collection at other functional areas (e.g., Radiology, Laboratory, or Internal Medicine) and collection for the MTF as a whole.

3.3.1 Interviews

Data collection protocol requires that the patient workload effort begin with an interview with the head of the functional area, in this case, Chief of Pharmacy Operations. The data collector should briefly state the purpose of the visit, and seek information as to the various means available to capture Pharmacy input/output transactions. At this point, the data collector may be introduced to a "working" contact, i.e. an administrative aide within the Pharmacy area familiar with functional input/output workloads. The interview may proceed with questions such as the following:

- What records or logs are used to record inpatient medication requests? Outpatient prescription requests?
- Are separate counts recorded for different Pharmacy output types, e.g., IV solution counts (inpatient), prescription refill counts (outpatient), narcotic medication counts (inpatient and outpatient), etc.?
- What time frame is employed to record these transactions? Hourly? Shift? Daily? Weekly? Monthly? Yearly?
- How does a data collector gain access to these records?
- Are prescriptions and order requests maintained in the Pharmacy files? How many records are maintained — maximum? minimum? average? How often are these records retired?
- What record keeping requirements apply to narcotic and controlled substances?
- What interactions exist between the Pharmacy and the Laboratory? Pharmacy and Radiology? Pharmacy and other functional areas?
- What information requests are received from other areas, i.e. patient medication profile data? How many and from what areas?
- Do any internal management reports record workload trends? How does one access these reports?
- How are the data recorded, i.e. by number of prescriptions, by number of patient requests, or by unit dose?
- What are the Pharmacy's peak seasons, times of the day, days of the week, etc.?
- What data management problems are encountered by the Pharmacy Department?

These and other questions, determined by type of MTF, type of functional area, and similar variations, will enable the data collector to assess other tools for the collection of patient workload information.

Similarly, communications loading (voice and records traffic) and physical facility (layout, access, and utilities) information may be obtained and directed through interviewing techniques, usually through the Public Works Office or the Civil Engineering Department. Again, data availability will be determined by the site specific variations at each MTF.

3.3.2 Records

The workload input and output records maintained by a clinic, hospital, or functional area may take a variety of forms. Monthly patient workload statistics, including both general (e.g., total inpatient visits) and functionally specific (e.g., Pharmacy output) counts, are usually prepared in a standard report form and forwarded to a higher medical command for administrative review. If the worksheets are available from which these monthly reports are obtained, weekly and daily input and output counts may also be collected. In the case of the Pharmacy, these monthly overview counts may reveal x inpatient medication units and y outpatient prescriptions per month. Files in the Patient Administration area will usually provide copies of these standard reports, going back for a significant period of time.

In addition, administrative sources within the Pharmacy may prepare more detailed monthly workload reports, showing medication outputs by type (i.e. w regular, x refill, y controlled, and z narcotic prescriptions). Peak input/output loadings may be shown, as well as other workload parameters. The use of such existing documentation may eliminate duplication in the data collection effort.

Patient workload data are also available through Pharmacy (and other department) logs. Information in the logs may be subdivided into smaller units than those reflected in the monthly workload reports, with each unit producing separate data communication impacts. Similarly, log data may directly link system input and output, i.e. patients (input) and medication issues (output). Logs may further provide information as to shift or even hourly workload variations, an important consideration in system sizing. Although these logs usually provide easy access for the data collector, it is possible to capture this information only by hand copying of the log data, a tedious and error-prone process.

Handouts prepared for facility beneficiaries may also provide site and functional workload data. For instance, a list of branch Pharmacies available within a given area may mention outlying branches overlooked in other reports or discussions. Beneficiary handouts may outline prescription or refill procedures, offer advice to avoid certain peak workload periods, or provide other information to the site workload characterization effort.

Finally, reports prepared by sources outside the clinic or hospital may furnish applicable site and function characterization data. The Bureau of Medicine and Surgery or other official sources may have issued a master workload plan for the MTF or the Pharmacy, providing past, present, and future estimates of the site or Pharmacy's workload. Outside consultants may have also gathered information useful to the present effort. These and other printed materials should be examined for applicability to the NIS input/output study.

3.3.3 Questionnaires

Data workload information not otherwise available may often be obtained through the use of patient questionnaires. Similarly, it may be advisable to obtain department input and output data through the use of a printed survey. Valuable personnel time may be saved through this method; additional benefits accrue because identical questions are asked of each participant, leading to greater uniformity in the answers supplied. With adequate follow-up, this method may be especially useful in establishing system dimensions for remote facility sites.

Figures 3-1 and 3-2 present two alternate questionnaires used in the Portsmouth NRMC study, each designed to obtain specific patient information. The questionnaire shown in Figure 3-1 provides data specifically related to appointments, follow-on treatment, points of interaction, and waiting periods; the form presented in Figure 3-2 concentrates on capturing the time and place of each data and material transaction. Depending upon the stated objectives of each questionnaire, one may discover that x percent of all outpatients receive services in the Pharmacy as the final part of their visit, or that y percent obtain appointments prior to clinic visits. Qualitative statements and comments appended to these questionnaires may identify existing problems in the workload communications environment, such as extreme waiting periods at the Pharmacy during certain hours. Other comments from the patient surveys may be applied to future workload planning requirements.

3.3.4 Machine Monitoring

- Time Stamp

With time stamp machines provided at selected data input/output stations throughout the facility or functional area, the surveyor may obtain precise minute-by-minute counts of communication impacts. For instance, when a prescription or order request is submitted at the Pharmacy, a card would be time-stamped and placed in a box; when the Pharmacy telephone rings with a status request for a certain set of patient medications, another card would record the time and type of transaction. Data accumulated on these cards could then be reduced using automated data processing equipment, identifying specific input/output concentrations as well as unit totals.

The time stamp method is especially suited to capturing query and response data, i.e. telephone and walk-in status requests requiring access to a data storage center. Although the quantity and manner in which these query and response transactions occur will be modified by the introduction of NIS system capabilities, pre-automation counts may be used as a basis for projecting future workload

VOLUNTARY PATIENT INFORMATION

This medical center wants to know what happens on your visit today. That way, the center will be able to provide better service in the future. So please answer these VOLUNTARY questions, to help the center help YOU.

Portsmouth Hospital Date _____

Branch Clinic _____ Time _____

Inpatient Outpatient

Did you make an appointment for today? YES NO

Time scheduled for appointment _____

Time appointment begins _____

Is today your first visit for your present condition? YES NO

Date of first visit _____

Place of first visit _____

Where did you go in the facility today?

1st place _____

2nd place _____

3rd place _____

others?

Will you return for further treatment of this condition? YES NO

Any significant delays or waiting periods? YES NO Please note below.

Time of departure today _____

Comments (use reverse side if necessary):

The Naval Regional Medical Center, Portsmouth, Virginia, is participating in on-going studies to evaluate patient care delivery. This VOLUNTARY form is designed to provide basic, important data concerning several specialty areas which impact your medical treatment. Your cooperation in completing this form will enable this facility and the Department of the Navy to improve patient care delivery to all beneficiaries. Thank you for your assistance.

PLEASE RETURN THIS FORM TO THE BOX LOCATED OUTSIDE THE PHARMACY WINDOW OR OUTSIDE THE OUTPATIENT RECORDS OFFICE.

Figure 3-1. Sample Patient Information Questionnaire - Alternate 1

PATIENT INFORMATION FORM

This Medical Center wants to know what happens on your visit today. That way, the Center will be able to provide better service in the future. So please answer these VOLUNTARY questions, to help the Center help YOU.

DATE _____
 TIME OF ARRIVAL _____

If you visit any of the following clinics today, please note the time you arrive:

<u>CLINIC</u>	<u>TIME</u>	<u>CLINIC</u>	<u>TIME</u>
Cardiology	_____	Neurology	_____
Dermatology	_____	Obstetrics	_____
Diabetes	_____	Oncology	_____
Ear, Nose & Throat	_____	Orthopedics	_____
Emergency Room	_____	Pediatrics	_____
Endocrinology	_____	Pharmacy	_____
Family Practice	_____	Physical Exam	_____
Gastroenterology	_____	Proctology	_____
General (Internal) Medicine	_____	Psychiatry	_____
General Surgery	_____	Pulmonary Medicine	_____
Gynecology	_____	Radiology (X-Ray)	_____
Hematology	_____	Rheumatology	_____
Hypertension	_____	Screening Clinic	_____
Laboratory	_____	Urology	_____
Nephrology	_____		

TIME OF DEPARTURE TODAY _____

The Naval Regional Medical Center, Portsmouth, Virginia is participating in on-going studies to evaluate patient care delivery. This VOLUNTARY form is designed to provide basic data concerning your medical treatment. Your cooperation in completing this form will enable this facility and the Department of the Navy to improve patient care delivery to all beneficiaries. Please use reverse side for comments. Thank you for your assistance.

BEFORE YOU LEAVE, PLEASE RETURN THIS FORM EITHER TO THE BOX LOCATED OUTSIDE THE PHARMACY WINDOW OR OUTSIDE THE OUTPATIENT RECORD OFFICE.

Figure 3-2. Sample Patient Information Questionnaire - Alternate 2

requirements. However, it should be noted that the time stamp method requires the time of the medical or administrative staff to be implemented.

- **Equipment Counts**

Another method for capturing functional patient workload data is through the monitoring of existing equipment on-site. Machines receiving input or producing output may already be equipped with meters to record volume transactions; if these counts are recorded on an hourly (or other) basis, the resulting data may be applied to the patient workload analysis. Examples of equipment with possible monitoring applications include telephone call stacking devices (input), specimen processing units (input/output), or medication dispensing machines (output).

3.3.5 Graphic Arts

Sketches, graphs, charts, photographs, and other graphic presentations may help to clarify and explain workload input/output transactions and the interrelationships among functional subsystems. These graphic displays may already be available on-site. If not, their preparation by the site surveyor may help to refine a workload systems analysis approach.

Graphic presentations are especially useful to the communications and facility profile effort, where the use of floor plans may reduce a several thousand word description to a few reproduced drawings. Lines, telephones, data terminals, power generators, air conditioners, and related physical facilities are readily characterized in a visual format. Similarly, voice and record traffic corridors may be graphically reduced for ease in a communications workload analysis.

SECTION 4
DATA ORGANIZATION

4.1 STATISTICAL PARAMETERS

Once the data collection effort has been accomplished, it becomes necessary to make some statistical sense of the various information which has been uncovered in the collection stage. This process of organizing and summarizing the collected information is known as data reduction. And just as consistency is the rule for data collection efforts, consistency remains the basis for data reduction, comparison, and analysis.

The Portsmouth NRMHC patient data reduction effort consistently focused on four statistical parameters:

- Mean (average, or arithmetic mean)
- Maximum, or Max (highest value)
- Minimum, or Min (lowest value)
- Standard Deviation, or S.D. (simply, an indication of how closely the values are clustered around the average)

Figure 4-1 illustrates the results of the data reduction process for a group of monthly inpatient and outpatient Pharmacy values at the Portsmouth Hospital. Please note that all of the organized counts represent the same time period (one month), thereby maintaining statistical consistency. All values included in the computations are also shown in this chart, providing further data as to workload variations. Figure 4-2 offers a graphic presentation of the Pharmacy values listed in Figure 4-1, providing an alternative means of presenting the organized data.

Of course, patient workload data reduction is not limited to the compilation of monthly input/output values. Perhaps daily workload counts were collected through outpatient Pharmacy logs. These data may be reduced into composite daily figures, i.e. all Monday data are collected and reduced into a Monday workload profile, all Tuesday data into a composite Tuesday, etc. Figures 4-3 and 4-4 present sample outpatient Pharmacy data, reduced per composite day both tabularly and graphically.

Another form of data organization is illustrated by Figures 4-5 and 4-6. Here, inpatient and outpatient Pharmacy issues are subdivided by type, with each medication category figured as a percentage of the total. Note the relative effectiveness of the graphic presentation in this case (Figure 4-6), whereby each Pharmacy output type is placed in immediate perspective.

Data reduction and organization may be produced from hourly, yearly, seasonal, or minute-by-minute workload counts, as long as the time frames compared remain consistent throughout each analysis.

PHARMACY ISSUES - PORTSMOUTH HOSPITAL

<u>Month</u>	<u>OP Units</u>	<u>IP Units</u>
1/77	37,971	30,917
2/77	37,078	31,739
3/77	40,358	39,429
4/77	36,874	35,371
5/77	38,545	36,966
6/77	37,871	41,458
7/77	33,880	33,496
8/77	40,489	37,935
9/77	36,604	44,076
10/77	38,352	38,002
11/77	39,696	36,691
12/77	41,361	39,194
1/78	54,285	34,012
2/78	39,964	40,319
3/78	46,859	35,900
4/78	39,754	32,235
5/78	46,274	31,433
6/78	40,500	38,406
7/78	34,295	40,878
MEAN	40,053	36,761
MAX	54,285	44,076
MIN	33,880	30,917
S.D.	4,751	3,749

Source: Medical Services and Outpatient Morbidity Reports.

Figure 4-1. Sample Data Presentation Format — Monthly Values, Table

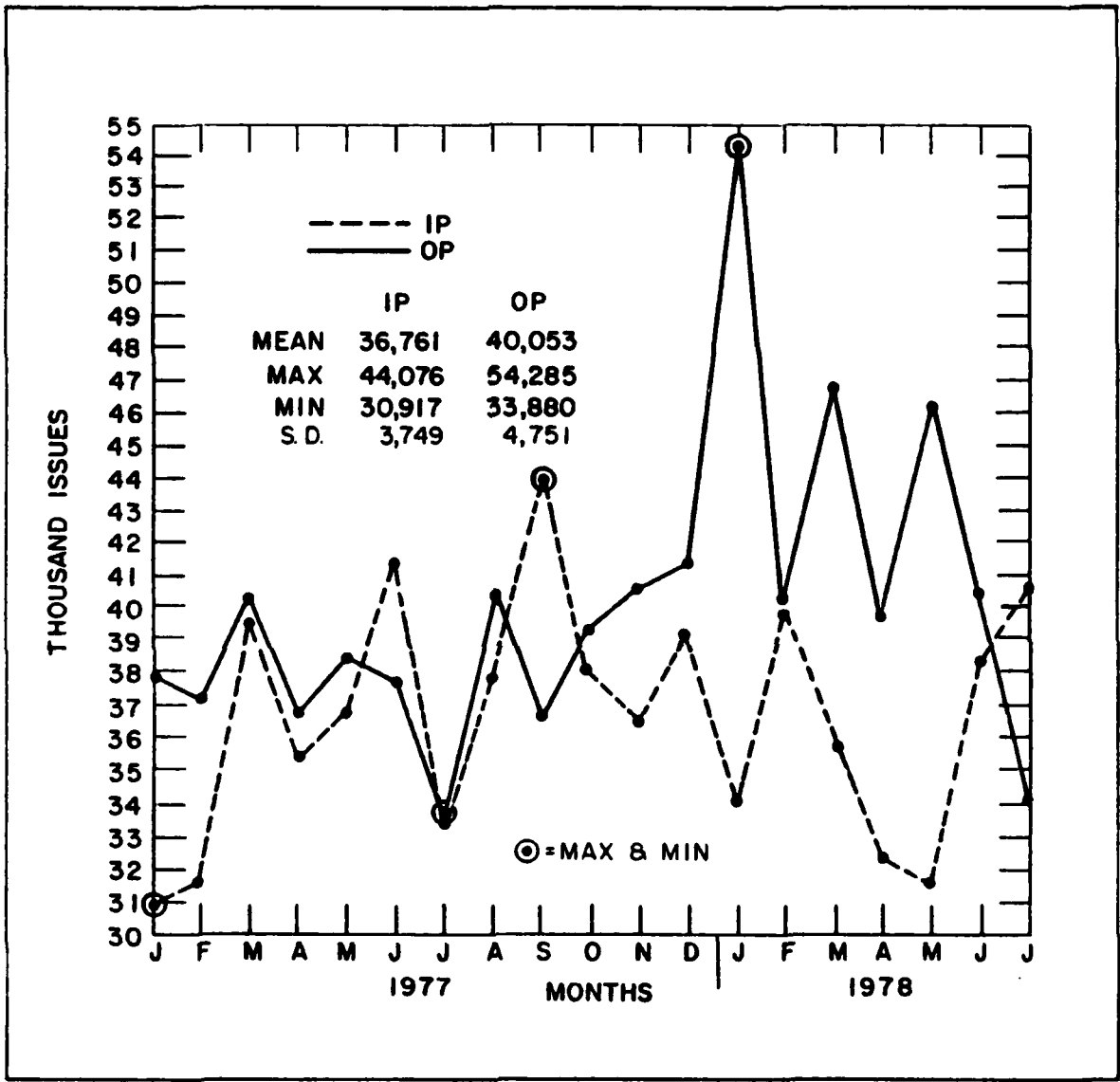

Figure 4-2. Sample Data Presentation Format — Monthly Values, Graph

OP PHARMACY ISSUES PER COMPOSITE DAY -
PORTSMOUTH HOSPITAL

	<u>MEAN</u>	<u>MAX</u>	<u>MIN</u>	<u>S.D.</u>
Monday	1,482	1,709	1,101	258
Tuesday	1,470	2,095	1,261	218
Wednesday	1,339	1,623	1,100	131
Thursday	1,343	1,643	900	154
Friday	1,215	1,507	985	136
Saturday	575	892	414	104
Sunday	477	725	295	108

n = 53 weeks (September 1977 - September 1978).

Source: Pharmacy log counts.

Figure 4-3. Sample Data Presentation Format — Daily Values, Table

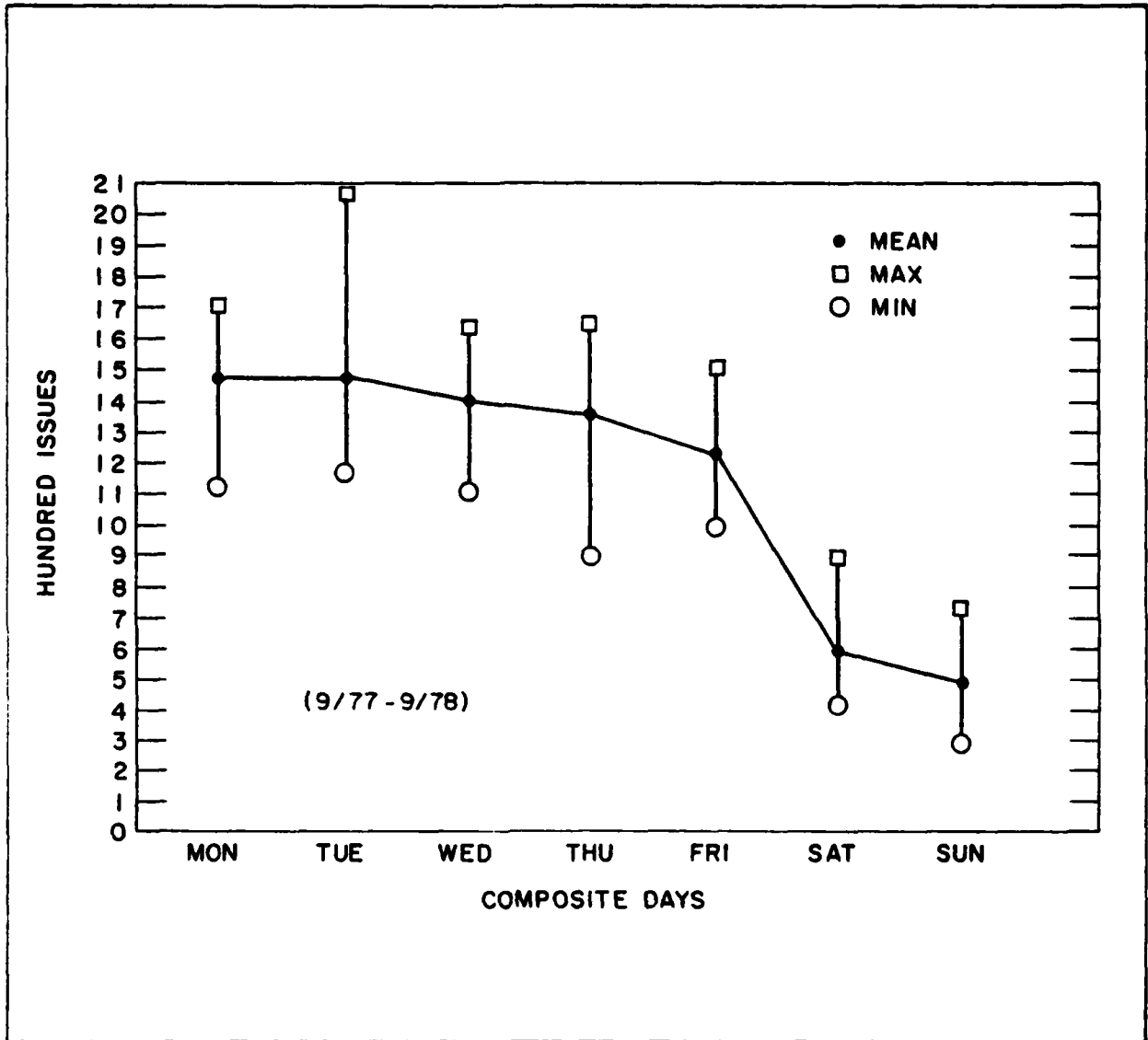

Figure 4-4. Sample Data Presentation Format — Daily Values, Graph

PHARMACY ISSUES BY TYPE -
PORTSMOUTH HOSPITAL

Outpatient Issues:

Regular	57%
Refills	18%
Clinic Issues	17%
Controlled	5%
Narcotics	<u>3%</u>
	100%

Inpatient Issues:

Ward Issues	62%
IV Additives	26%
Regular	7%
Narcotics	3%
Controlled	<u>2%</u>
	100%

Period = 6 months (April - September 1978).

Total Issues Reported During Sampling Period = 460,878.

Source: Administrative records.

Figure 4-5. Sample Data Presentation Format -- Percent of Total, Table

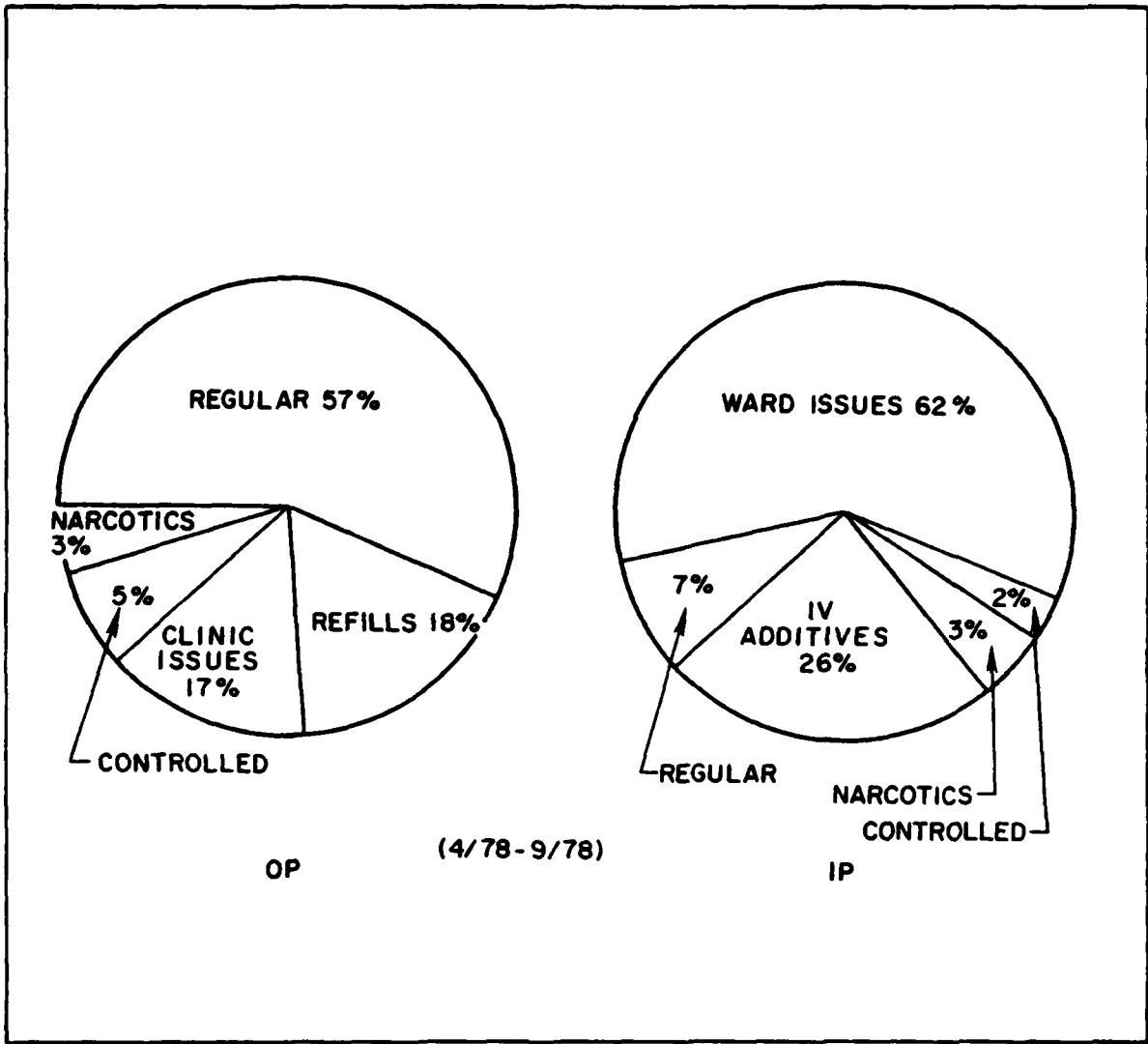

Figure 4-6. Sample Data Presentation Format -- Percent of Total, Graph

4.2 SITE AND FUNCTION STATISTICAL RELATIONSHIPS

Patient workload data reduction should include a statistical assessment of the way in which the separate functional areas relate to the MTF as a whole. For example, once it is determined that an average of m outpatient Radiology exposures are performed each month, and that a monthly average of n outpatient visits occur, it may be established that x Radiology exposures may be expected per outpatient visit (m divided by n). Information such as this may be utilized in planning for future workload demands. In addition, it may illustrate seasonal variations in the demand for certain services (for example, peak Lab test-to-patient ratios during late winter flu season). Site and function statistical relationships may also be expressed in a percentage form, i.e. $z\%$ of all patient visits are initiated in the Screening Clinic.

4.3 INTERFUNCTIONAL STATISTICAL RELATIONSHIPS

The various functional areas within a given facility also interact in a way suitable for statistical analysis. For example, it may be determined that $x\%$ of all Pediatrics patients obtained appointments prior to their visit, while only $y\%$ of all Radiology patients are scheduled in advance. Another approach might establish that each Obstetrics patient generates an average of m Laboratory tests and n Pharmacy units with each outpatient visit. Identification of the significant points of interfunctional relations may often be obtained through the interview process. Then, following collection of supporting data, an analysis of these interactions will provide additional input to the NIS site characterization effort.

4.4 NARRATIVE PRESENTATION

Many workload parameters are best presented in a narrative form, accompanying the input/output charts, graphs, and tables. Following are several elements which may be presented in text form.

4.4.1 Operations Overview

The way in which a department or MTF organizes its operations will affect its data and material transactions. For instance, if the Pharmacy dispenses inpatient medications using a unit dose system (with a single dosage of medication contained in each packet, individually labeled by patient), its data communications impact will differ from another Pharmacy operating under a ward issue system (with inpatient medications removed from a centralized inventory of commonly used drugs). On an MTF-wide level, operations may be arranged so that all Ear, Nose & Throat appointments are referred to a branch clinic specializing in ENT, while another branch clinic specializing in Psychiatry may receive referrals from other areas. These and other operational parameters should receive narrative treatment in the NIS site characterization study.

4.4.2 Data Flow Protocols

When data or materials flow from one point to the next on a routine basis, there exists a data flow protocol suitable for inclusion in the data analysis effort. Does

the Laboratory route copies of its surgical pathology reports to the Radiology Department? Do outpatients pick up their own records prior to a clinic visit, or are the records already on hand at the appointed clinic? These and other questions regarding data flow transactions should be examined for inclusion in a narrative analysis.

4.4.3 Trends

Trends may be hard to quantify based upon existing records. However, interviews may reveal that increasing numbers of asbestos workers are seeking Laboratory testing, or that rising gasoline prices are proportional to the incident of motorcycle accidents (with their resulting Radiology and Emergency Room impacts). These and other trends related to patient workload inputs and outputs may also be included in a site's narrative analysis.

4.4.4 Qualitative Profile

The unique political, economic, social, and physical characteristics of an area will also impact the data communications of a given facility or department. An MTF in the Sunbelt might expect greater than average Dermatology visits during summer sunburn months. Food service workers in an agricultural area may require periodic Laboratory tests to comply with government regulations. Or the popularity of skateboards in another area might contribute to peak Radiology workloads during school vacation periods. Climate, lifestyle, pollution, nutrition, and many other qualitative factors which influence the medical environment might be subject for site characterization analysis.

4.4.5 Summary

The narrative portion of the NIS site characterization study should also include a brief summary analysis of the information contained in the supporting tables, graphs, and charts. In summarizing, it is enough to mention that, "Monday workloads are heavy in Physical Therapy," or "Summer months are slow in the Pharmacy," if figures to support these claims accompany the narrative text. Such summaries will draw additional focus to significant points, and will add clarity to the resulting NIS site characterization study.

SECTION 5

METHODS COMPARISON

5.0 METHODOLOGY SELECTION

When the time comes to finally decide upon a suitable data collection methodology for a specific MTF, any number of constraints may inhibit the decision making process. With unlimited time, money, and personnel, no such problems would arise. However, given the unique circumstances surrounding each study, program planners must prepare to make certain trade-off decisions: To what degree should accuracy be sacrificed for economy? Are the site characterization findings required next week, next month, or next year? Should remote facilities receive an on-site analysis, or will telephone calls and mail correspondence suffice? Is one data collector required for a four-week survey, or should four data collectors survey for one week? What technical and analytical skills should the data collector(s) possess? How much time should be allowed for data collection and data reduction?

The following paragraphs illuminate some of the strengths and weaknesses of the collection methodologies discussed thus far. Table 5-1 shows a summary comparison of these methodologies.

5.1 INTERVIEWS

A major strength of the interview process is the speed with which one can collect and reduce the required data; rather than tediously copying log books, xeroxing report forms, and performing statistical analyses of the resulting data, the data collector invests a relatively small amount of time in asking questions and reporting answers. However, this advantage may be obtained at some cost of accuracy, since interviewees may vary significantly in the validity of their responses. Effective interviewing techniques are also required to obtain the best data available from these contacts. Furthermore, some interview contacts may work within tight schedules which conflict with the NIS data collection effort. However, interviews still prove to be a most flexible means of collecting information related specifically to the study at hand.

5.2 RECORDS

A high degree of data accuracy may be obtained through the record analysis method. In addition, pertinent records are usually easily available to the data collector, and this method of collection requires little training or special skills. However, both data collection and data reduction may be most time-consuming when employing this methodology. Another limitation involves methodology flexibility; the data collector can only obtain access to records which are already available on-site. Still, the record analysis method requires little training and provides accurate results.

Table 5-1

METHODS COMPARISON SUMMARY

<u>Method</u>	<u>Data Accuracy</u>	<u>Data Availability</u>	<u>Method Flexibility</u>	<u>Collection/Reduction Speed</u>	<u>Method Simplicity</u>
Interviews	M	M	H	H	M
Records	H	H	M	L	H
Questionnaires	L	L	M/H	L	M
Equipment Counts	H	M	L	M	H
Time Stamps	H	L	H	M	L

H = High
 M = Moderate
 L = Low

5.3 QUESTIONNAIRES

A questionnaire may be designed in such a way that various types of required information may be made available. Its flexibility is relatively high with regard to the specifics of the NIS site characterization study. Unfortunately, many drawbacks exist. Special skills are required to design an effective questionnaire format, especially when these questionnaires are directed at patients of varying education and comprehension levels. Data accuracy may be negatively affected by the questionnaire format, or by the backgrounds of the respondents. Much time may be required to circulate the forms, gather or collect them, and reduce the resulting data into an acceptable form. It is usually necessary to distribute several times more questionnaires than are needed to insure a sufficient return for meaningful analysis. However, the relative flexibility of the questionnaire format in obtaining data otherwise unavailable makes it an alternative candidate for consideration in the NIS analysis.

5.4 EQUIPMENT COUNTS

Data produced from the monitoring of input/output equipment counters yield highly accurate results. The methodology itself is simple enough and requires no special training. Data collection and reduction times are reasonable and staff monitoring support can usually be obtained. However, this method may only be employed where processing units are equipped with counting devices suitable for monitoring of NIS data collection requirements. The flexibility of this methodology is therefore highly limited. Where suitable equipment monitoring devices are available, their use may be extremely rewarding.

5.5 TIME STAMPS

The use of time stamp machines may provide the most complete and accurate data available to the NIS site characterization effort. With adequate planning, their flexibility may be applied to a wide variety of ends. The problem with this methodology lies with its degree of difficulty and advance planning requirements. The site data collector must be prepared to instruct various persons within the functional areas concerning input/output criteria of NIS site characterization requirements and, further, must coordinate their separate efforts. This method will also require time from the medical or administrative staff members within the functional areas employing the time stamps. In addition, capital expenditure on time stamp machines in each area to be impacted by NIS may be a significant constraint. However, data collection and reduction times are moderate, and the significant and specific information obtained from the employment of a time stamp methodology may justify its implementation difficulties.

SECTION 6

TECHNICAL AND MANAGEMENT OVERVIEW

6.0 NETWORK INTERFACE SYSTEM IMPLEMENTATION

NIS may be defined by describing its communications operating requirements. Its successful design and implementation depend upon valid, quantitative trade-off analyses derived from requirements based on system loading data of known accuracy. NIS is a conventional on-line interactive data communications system, with central data base management and report generation. Figure 6-1 schematically indicates how NIS functions as an on-line interactive system.

6.1 COMMUNICATIONS NETWORK ANALYSIS

Determination of the optimum NIS configuration depends upon three main system operating factors. The first of these is SPACE, meaning the physical or geographical distribution of the transmitting and receiving elements interfacing with the system. The second is TIME, that is, the required speed of data transmission and allowable delay of system response. The third is QUANTITY, or the number of bits to be transmitted in a given message or defined time period. Other factors exist which are of secondary importance, including accuracy, availability, reliability, and security. Figure 6-2 is furnished to indicate the functional relationship of NIS and its interfaces.

6.1.1 Geographical Distribution

The functional allocation of the NIS elements portrayed in Figure 6-2 suggests their geographical distribution as well. Each of the indicated subsystems interfacing with NIS is physically isolated from the others. A regional medical center such as NRMC Portsmouth may have several satellite clinics located relatively distant from the main hospital. Here, portrayal of the NIS should be understood to present a functional rather than a physical arrangement of communications lines.

6.1.2 Time and Quantity

The interrelationship of the quantity of data (or more precisely, bits) and the time allowed to deliver it determines the speed of data transmission required on any of the rays of the "STAR" network format shown in Figure 6-2. The subsystem specifications for Patient Appointment Scheduling, Radiology, Laboratory, and Pharmacy indicate that times of response for communications (other than transmittal of lengthy reports) lie within the range of one second to one minute. Messages may vary in size from 100 to 100,000 bits. Report generation would range from 10,000 to 10,000,000 bits or more, with required response times of one minute to one day.

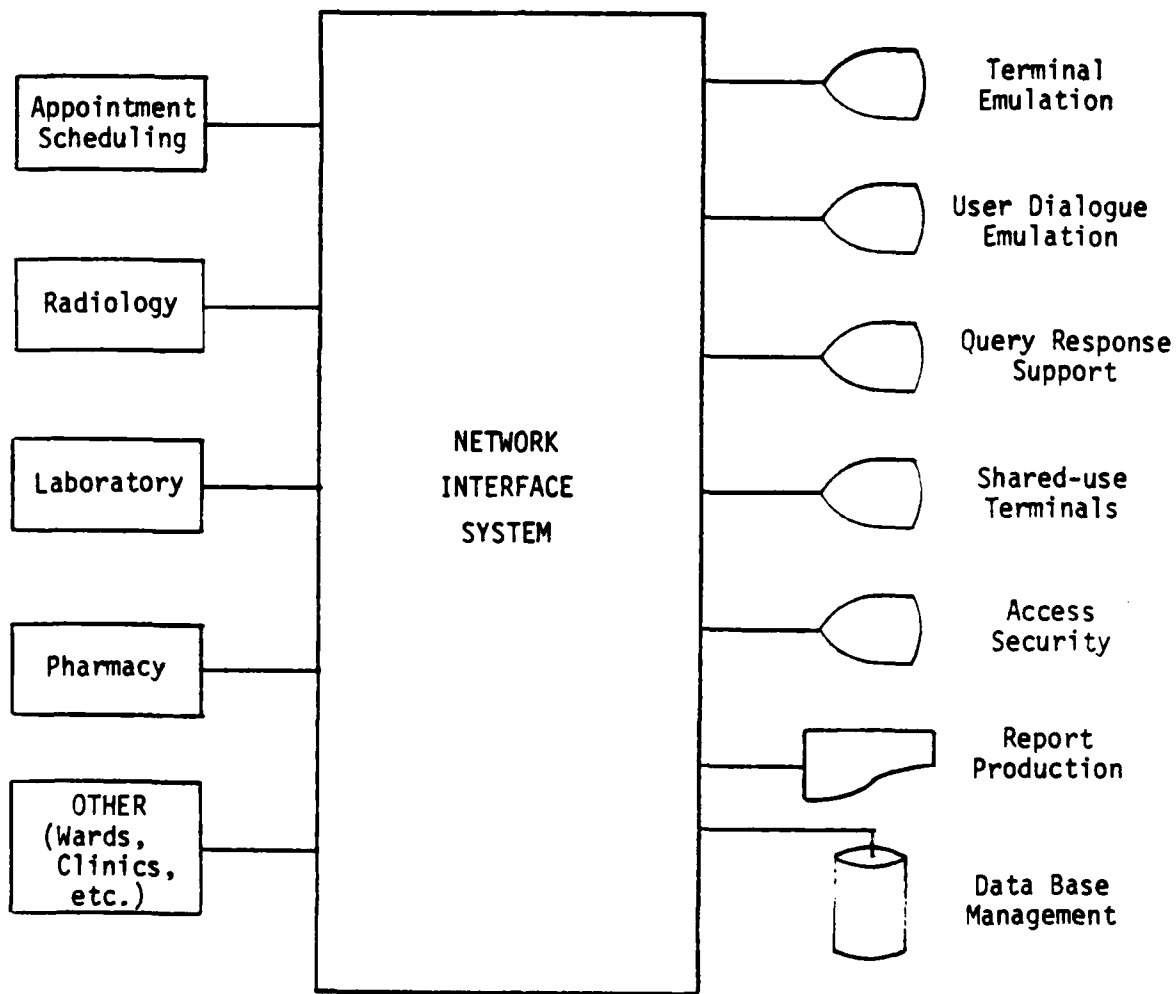

Figure 6-1. Network Interface System Requisite Capabilities

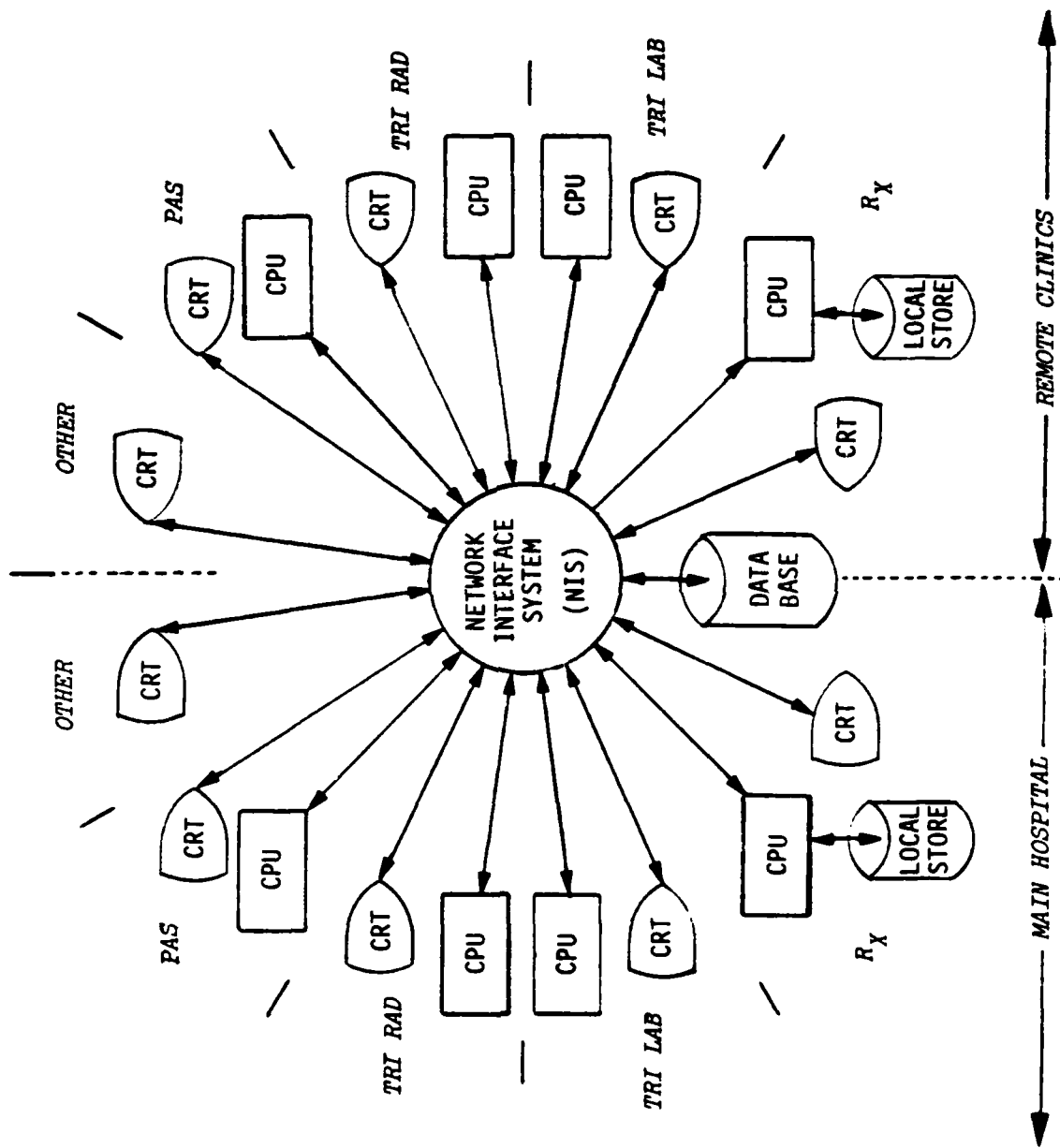

Figure 6-2. NIS Represented as a "STAR" Network

6.2 NETWORK INTERFACE SYSTEM REQUIREMENTS

Given the STAR network format, a definition of specific requirements for the duplex transmission on each ray is required. Each element of the two-way transmission requirements must be understood and defined. A single transmission consists of four elements: the transmitter; the message; the transmission medium; and the receiver.

6.2.1 Transmission Elements

The transmitter consists of either the human/machine interface terminal device or the computer interface. (These two alternate as transmitter and receiver on many duplex transmissions.) The message may be blocks of data that form the elements of a cathode ray terminal (CRT) display screen, a wire note, or a lengthy narrative supplementing a previously formatted display. The transmission medium has not been defined, but in all likelihood telecommunication will be by means of either dial-up or dedicated circuits, coaxial cable, or similar mechanisms.

6.2.2 Patient Loading Versus NIS Requirements

Each of the subsystems slated for NIS characterization must be examined to determine the relationship between patient loading and message loading on the interconnections between it and the NIS. Each of the subsystems receives one or more inputs, operates on each input, and creates (an "explosion" of) outputs as a result of a patient action or visit. A thorough study is necessary to determine the amount of data that will be transmitted by the NIS. The survey must indicate not only the average use of the terminals, but also how the volumes vary month by month, day by day, and hour by hour. The system must be configured to handle the peak traffic volume during the peak periods. Statistics on how rapidly the traffic builds up and dies away again are necessary. These are important in order to determine what queues will develop. Traffic volume figures must be projected forward to indicate how the load on the terminal will vary after installation. A histogram showing the frequency of occurrences of messages of different lengths may also be provided.

For a detailed treatment of data communications systems analysis, the reader is encouraged to see Martin, J.L., Systems Analysis for Data Transmissions, Prentice Hall, 1972.

SECTION 7

REFERENCES

Network Interface System (NIS) Site Workload Characterization Study; Naval Regional Medical Center (NRMC), Portsmouth, Virginia, Naval Ocean Systems Center Technical Note 644, 2 April 1979.

Network Interface System (NIS) Site Facility Profile Study; Naval Regional Medical Center (NRMC), Portsmouth, Virginia, Naval Ocean Systems Center Technical Note 645, 2 April 1979.

"Network Interface System Site Characterization Study," letter, Commanding Officer, Naval Medical Data Services Center, Bethesda, MD, to Commander, Naval Ocean Systems Center, San Diego, CA, NMDSC 04-FCS:mw 5260/29, Ser. 0225, 1 September 1978.

TriService Medical Information Systems, The Master Plan, 3 March 1978.

TRIMIS Patient Appointment and Scheduling (PAS) Summary Functional Requirements, TP-13001, 21 October 1977.

TRILAB II Summary Functional Requirements, TPO-19001, 31 October 1977.

Radiology Summary Functional Requirements, TP-01200.1, 20 September 1977.

Pharmacy Summary Functional Requirements, TP-25001, 20 September 1977.

Systems Analysis for Data Transmissions, J.L. Martin, Prentice Hall, 1972.

APPENDIX A
NIS SITE CHARACTERIZATION
DATA COLLECTION CHECKLIST

**NIS SITE CHARACTERIZATION
DATA COLLECTION CHECKLIST**

Facility _____

Dates _____

PATIENT WORKLOAD

	INPUTS			OUTPUTS		
	Units/ Month	Units/ Day	Others (specify)	Units/ Month	Units/ Day	Others (specify)
Total Facility Visits						
Inpatients (IP)						
Outpatients (OP)						
Catchment Population						
Central Appointments						
Laboratory IP						
Laboratory OP						
Radiology IP						
Radiology OP						
Pharmacy IP						
Pharmacy OP						
Clinics:						
Cardiology IP						
Cardiology OP						
Dermatology IP						
Dermatology OP						
Emergency Room						
Gastroenterology IP						
Gastroenterology OP						
General Medicine IP						
General Medicine OP						
Gynecology IP						
Gynecology OP						
Immunization IP						
Immunization OP						

PATIENT WORKLOAD

	INPUTS			OUTPUTS		
	Units/ Month	Units/ Day	Others (specify)	Units/ Month	Units/ Day	Others (specify)
Military Sick Call						
Obstetrics IP						
Obstetrics OP						
Ophthalmology IP						
Ophthalmology OP						
Orthopedics IP						
Orthopedics OP						
Pediatrics IP						
Pediatrics OP						
Physical Exam						
Physical Therapy IP						
Physical Therapy OP						
Proctology IP						
Proctology OP						
Psychiatry IP						
Psychiatry OP						
Screening Clinic						
Urology IP						
Urology OP						
Other Clinics:						
_____ IP						
_____ OP						
_____ IP						
_____ OP						
_____ IP						
_____ OP						
_____ IP						
_____ OP						

(Use additional sheets if necessary)

COMMUNICATIONS WORKLOAD

- _____ **Voice Systems**
- _____ ● **Number of Lines**
- _____ ● **Number of Telephone Instruments**
- _____ ● **Grades of Service**
- _____ ● **Expansion Potential**
- _____ **Digital Systems**
- _____ **Record Communications Systems (i.e. Naval Message Service)**

FACILITY PROFILE

- _____ **Power Availability (Normal/Emergency)**
- _____ **Air Conditioning Rating (BTU/TON/CFM)**
- _____ **Installed ADP Systems**
- _____ **Fire Protection Systems**
- _____ **Floor Plans/Room Numbers**
- _____ **Access Routes**
- _____ **Preliminary Installation Planning**
- _____ **Cable/Tray Capacity**

POINTS OF CONTACT

<u>Department</u>	<u>Name</u>	<u>Telephone</u>
_____	_____	_____
_____	_____	_____
_____	_____	_____
_____	_____	_____
_____	_____	_____
_____	_____	_____
_____	_____	_____
_____	_____	_____
_____	_____	_____
_____	_____	_____
_____	_____	_____
_____	_____	_____
_____	_____	_____
_____	_____	_____
_____	_____	_____