

AD-A088413



TECHNICAL LIBRARY

AD

AD-E400 463

TECHNICAL REPORT ARLCD-TR-79012

ELECTRO-OPTICAL INSPECTION SYSTEM FOR PACKED M42/M46 GRENADES

EDWARD G. KESSLER

AUGUST 1980



US ARMY ARMAMENT RESEARCH AND DEVELOPMENT COMMAND
LARGE CALIBER
WEAPON SYSTEMS LABORATORY
DOVER, NEW JERSEY

APPROVED FOR PUBLIC RELEASE; DISTRIBUTION UNLIMITED.

The views, opinions, and/or findings contained in this report are those of the author(s) and should not be construed as an official Department of the Army position, policy or decision, unless so designated by other documentation.

Destroy this report when no longer needed. Do not return it to the originator.

The citation in this report of the names of commercial firms or commercially available products or services does not constitute official endorsement or approval of such commercial firms, products, or services by the United States Government.

REPORT DOCUMENTATION PAGE		READ INSTRUCTIONS BEFORE COMPLETING FORM
1. REPORT NUMBER Technical Report ARLCD-TR-79012	2. GOVT ACCESSION NO.	3. RECIPIENT'S CATALOG NUMBER
4. TITLE (and Subtitle) ELECTRO-OPTICAL INSPECTION SYSTEM FOR PACKED M42/M46 GRENADES		5. TYPE OF REPORT & PERIOD COVERED
		6. PERFORMING ORG. REPORT NUMBER
7. AUTHOR(s) Edward G. Kessler		8. CONTRACT OR GRANT NUMBER(s)
9. PERFORMING ORGANIZATION NAME AND ADDRESS ARRADCOM, LCWSL Applied Sciences Division (DRDAR-LCA-P) Dover, NJ 07801		10. PROGRAM ELEMENT, PROJECT, TASK AREA & WORK UNIT NUMBERS
11. CONTROLLING OFFICE NAME AND ADDRESS ARRADCOM, TSD STINFO (DRDAR-TSS) Dover, NJ 07801		12. REPORT DATE August 1980
		13. NUMBER OF PAGES 27
14. MONITORING AGENCY NAME & ADDRESS (if different from Controlling Office) U.S. Army Materials and Mechanics Research Center Watertown, MA 02172		15. SECURITY CLASS. (of this report) Unclassified
		15a. DECLASSIFICATION/DOWNGRADING SCHEDULE
16. DISTRIBUTION STATEMENT (of this Report) Approved for public release; distribution unlimited.		
17. DISTRIBUTION STATEMENT (of the abstract entered in Block 20, if different from Report)		
18. SUPPLEMENTARY NOTES		
19. KEY WORDS (Continue on reverse side if necessary and identify by block number)		
Optics	Non-destructive inspection	
Optical inspection	Automation	
Pattern recognition	Munitions	
Electro-optics	Quality control	
20. ABSTRACT (Continue on reverse side if necessary and identify by block number)		
<p>An in-house, experimental program was conducted to develop an electro-optical inspection system for use on M42/M46 grenades packed in M483 projectile bodies.</p> <p>Two distinct approaches to this problem are evaluated. The first approach, useful where the grenade orientation is known, is based on the use of fiber-optic proximity sensors which signal when grenade components have exceeded</p>		

UNCLASSIFIED

SECURITY CLASSIFICATION OF THIS PAGE(When Data Entered)

20. ABSTRACT (Continued)

their allowable range of travel. The second approach, useful for random grenade orientation, is based on projecting a band of light onto the grenade. From the apparent profile of the band, viewed from above, the grenade status can be inferred. Grenade condition is analyzed by microcomputer using input from carefully placed monitoring photodetectors.

The program demonstrates a novel inspection system with good potential for development into a working factory model.

UNCLASSIFIED

SECURITY CLASSIFICATION OF THIS PAGE(When Data Entered)

TABLE OF CONTENTS

	Page No.
Introduction	1
The Problem	2
Basic Approach	3
Missing Spacers or Components	3
Discriminating Between M42 and M46 Grenades	4
Inspection for Extension of the Arming Slider	4
Inspection for Proper Ribbon Folding	6
Experimental Setup	7
Discussion of Results	13
Case I - Fixed Orientation	13
Case II - Unknown Orientation	13
Conclusions	18
Distribution List	21

FIGURES

1	Configuration of M42 and M46 grenades	1
2	Inspection requirements	2
3	One layer of grenades in M483 projectile	3
4	Fiber optic proximity sensor	4
5	Effect of separating the light source from the photodetector on the field of view	5
6	Relationship of lower light cone to arming slide	6
7	Illumination patterns formed on grenades as viewed from above	7
8	Configuration to monitor for correct grenade packing - orientation known	8
9	Lab setup for inspecting grenades orientation fixed	8
10	Schematic for proximity sensor	9
11	Experimental setup	10
12	Schematic for one element of photoconductor ring	11
13	Lab setup - second approach	11
14	Photodetector array	12
15	Logic flow chart diagram for use in grenade inspection	15
16	A suggested configuration for the optical inspection head	17

INTRODUCTION

Presently M42 and M46 grenades are hand packed into M483 projectiles. Manual packing is a slow process and a program is underway to automate this operation. As part of the operation, the packer checks visually to assure that the grenades are in proper operating condition. Insignificant as this check appears, if omitted, the whole packing process is compromised.

Unfortunately, a visual check that is simple for the packer to accomplish can be very difficult to duplicate in a machine. Hence, a sophisticated inspection system needs to be developed to perform this inspection. The major effort of the automation program could very well be to provide a proper inspection system.

The goal of this study is to demonstrate the feasibility of a high speed, non-contact optical inspection system for use on M42 and M46 grenades (fig. 1).

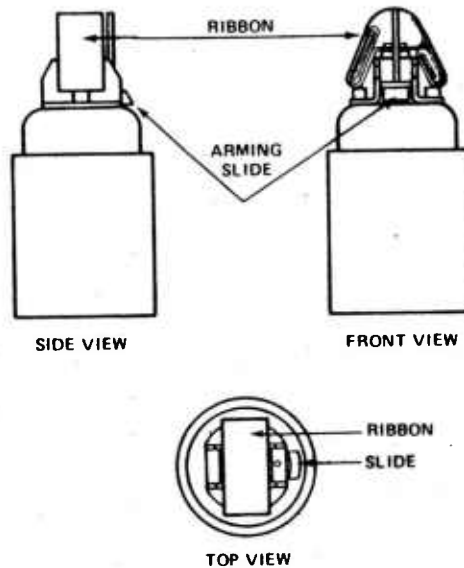

Figure 1. Configuration of M42 and M46 grenades.

THE PROBLEM

Inspection (fig. 2) is to assure that:

1. There are no missing spacers or components.
2. M42 and M46 grenades have not become intermixed.
3. The arming slider is not extended.
4. The grenade ribbon is not unfurled.

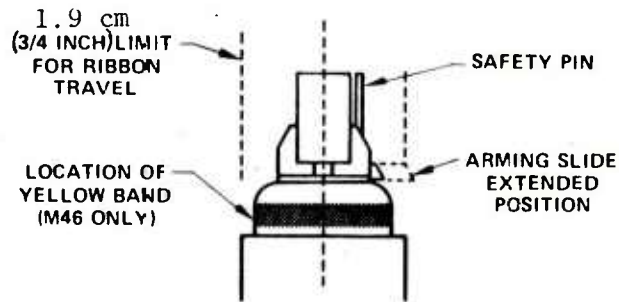

Figure 2. Inspection requirements.

Of this list, item 3 is the most critical because the extension of the slider means that a live grenade is packed in the projectile, a very dangerous situation. The slider is extended when it exceeds 1.59 cm (5/3 in.) from the grenade's central axis.

In the M483 projectile, the grenades are packed eight to a layer, eleven layers to a projectile (fig. 3). The three lower layers consist of M46 grenades, while the top eight layers consist of M42 grenades. The M46 grenades are distinguished by a yellow band painted around the collar.

The grenades are held in position within each layer by highly reflective white spacers (not shown).

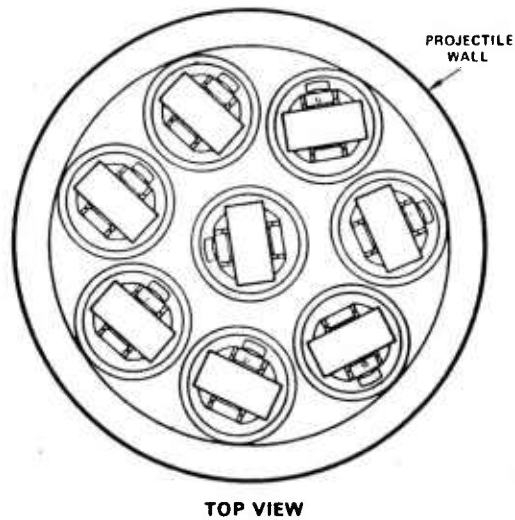

Figure 3. One layer of grenades in M483 projectile.

BASIC APPROACH

Missing Spacers or Components

Fiber optic proximity sensors are used to determine the presence or absence of critical items. Figure 4 illustrates the essential features of a fiber optic proximity sensor. In operation, light is fed into one end of a fiber optic light guide. The light is conducted to the far end where it is emitted into space. If there is a solid object close to the end, it will reflect light into the second light guide. Here it is conducted to a photodetector which puts out a voltage proportional to the light it receives, that is, to the proximity of the object. The thresholding device turns on when the photodetector output exceeds a preset voltage which occurs when an object comes within a predetermined distance of the fiber optic ends.

By terminating a proximity sensor near each spacer or component, its presence can be determined.

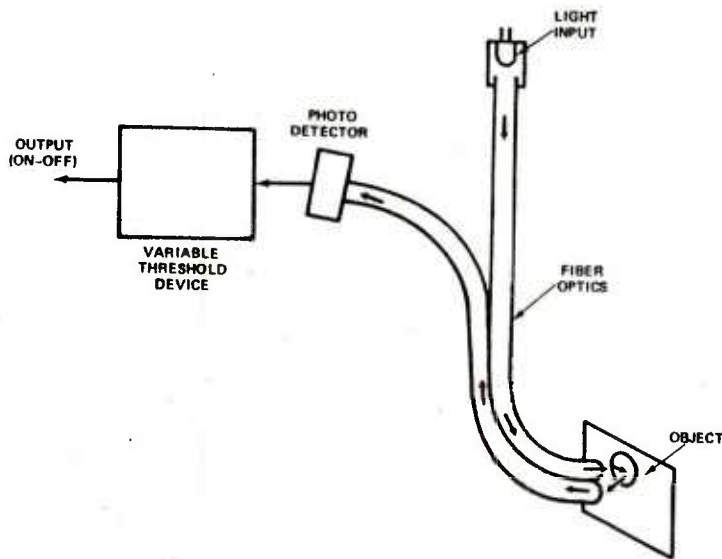

Figure 4. Fiber optic proximity sensor.

Discriminating Between M42 and M46 Grenades

Fiber optic proximity sensors are also used in this step. However, for this purpose, advantage is taken of the fact that the yellow band on the M46 grenades displays a much greater reflectivity than does the flat, gray finish of the M42 grenade. To separate the two reflectivities, the proximity sensor is set to trigger only when it receives the higher light level reflected from the M46 grenade.

The same mechanism can be used to distinguish metal from plastic spacers.

Inspection for Extension of the Arming Slider

Figure 5 illustrates our approach for detecting the extended arming slider. In operation, light is projected so that it just skims the slider when it is not extended. Any extension of the slider will penetrate the light beam and illuminate the slider. In conjunction with the light, a lens is used to image the illuminated, extended slider onto a photodetector providing the indicated field of view. As the slider extends and penetrates the illuminated zone, the combination puts out a signal proportional to the slider extension. The photodetector is thresholded and turns on at any desired degree of slider extension. By limiting the field of

view through the use of stops, the combination can be made quite sensitive to minor variations in slider position.

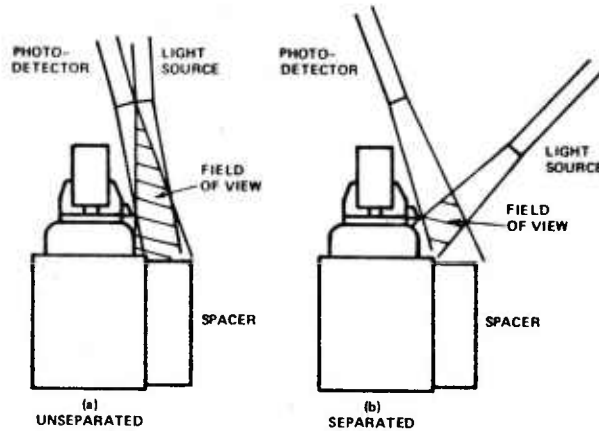

Figure 5. Effect of separating the light source from the photodetector on the field of view.

Unfortunately, due to the highly reflective background, the detector/light source pair must be separated [fig. 5(b)]. Separation prevents reflections off the background objects (the grenade lip and the spacers) from overwhelming the relatively weak return of the slider.

If the grenade orientation is known, only one photodetector/light source combination need be used for positive triggering. With random orientation, the grenade need be entirely encircled with a cone of light (fig. 6) and viewed with a ring of thresholded photodetectors to assure positive slider detection, regardless of location.

Notice that, in the position indicated, the ribbon can also penetrate the light cone and trigger one or more of the photodetectors. Hence, a mechanism need be provided to determine the exact cause of photodetector triggering. These mechanisms are described in detail later in this report.

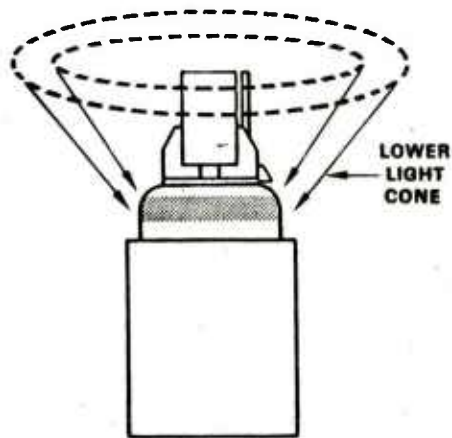

Figure 6. Relationship of lower light cone to arming slide.

Inspection for Proper Ribbon Folding

To inspect the status of the ribbon, the previously mentioned cone of light is raised 1.3 cm (1/2 in.) to illuminate the ribbon (fig. 7). Viewed from above, the pattern projected on the grenade appears as two parallel bars of light with the ribbon properly folded [fig. 7(b)]. Unfurling the ribbon causes variations in the basic pattern. For example, partial unfurling to one side forms a "c" pattern as illustrated in figure 7(c). Additional ribbon displacement further displaces the illumination pattern. By optically monitoring the apparent configuration of the illumination pattern, the displacement and orientation of the ribbon may be determined.

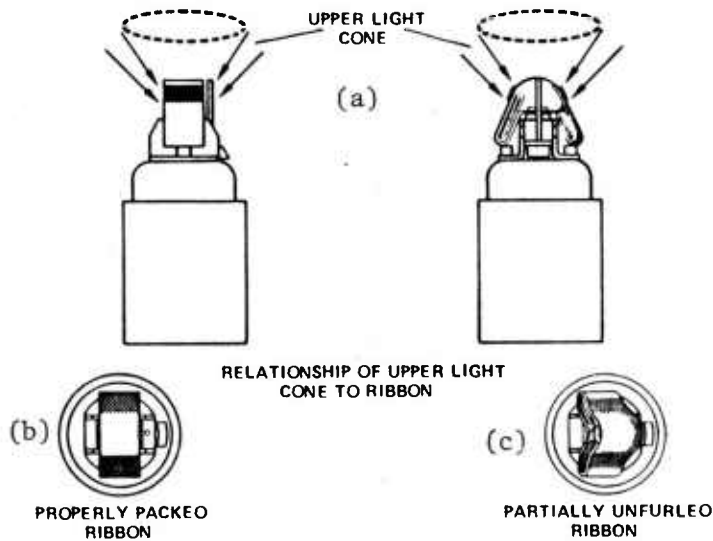

Figure 7. Illumination patterns formed on grenades as viewed from above.

EXPERIMENTAL SETUP

The complexity of the problem depends on the definition of proper packing. At this point, the exact criteria defining proper ribbon packing are unspecified and, accordingly, experimental work was conducted to cover the spectrum of possible requirements.

The first experimental setup assumed a known, fixed grenade orientation. The second setup provided numerous outputs that were analyzed by a microcomputer. The second approach provided sufficient sophistication to meet the most difficult of the probable inspection criteria, the philosophy being that the complexity of this approach could be reduced easily if inspection requirements were relaxed.

Figure 8 illustrates the experimental approach to inspecting the grenade with fixed and known orientation. In this case, extension of the slider places an output on the slider proximity sensor, while the ribbon's traveling beyond its allotted volume puts an output on one or more of the outer proximity sensors.

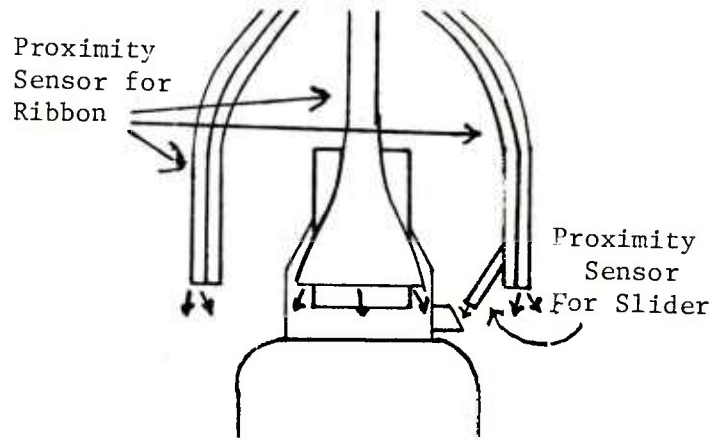

Figure 8. Configuration to monitor for correct grenade packing - orientation known.

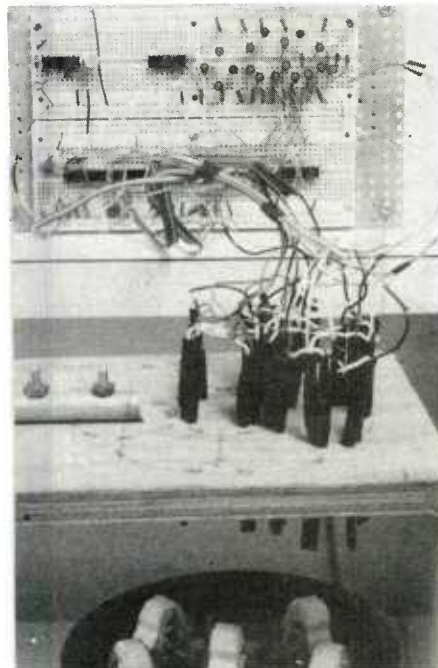

Figure 9. Lab setup for inspecting grenades orientation fixed.

The proximity sensors were constructed to DuPont "Crofon" plastic fiber optics (fig. 10). The light source consists of Dia-light 558-0101 LED's (light-emitting diodes). The photodetectors were CL 904L photoconductive cells. The output of the proximity sensors was visually monitored by use of an LED array. Any output was an indication of an unacceptable grenade.

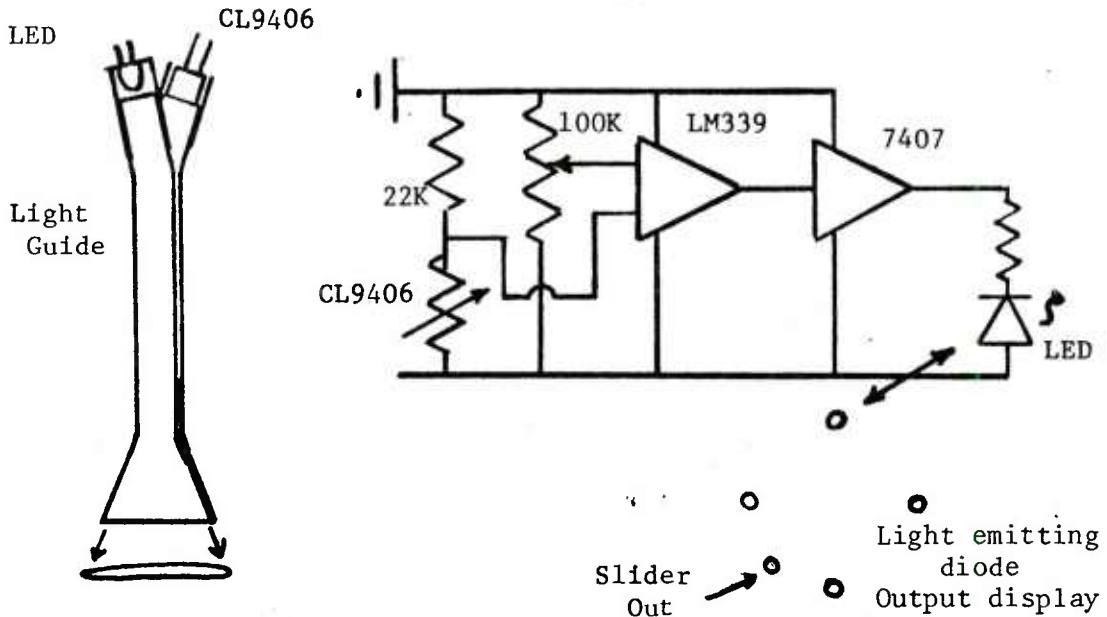

Figure 10. Schematic for proximity sensor.

Figures 11 and 12 illustrate the laboratory setup used in developing the second approach; figure 13 provides a photo of the apparatus. The system was fabricated for use on a single grenade. The space occupied is greater than that available under actual working conditions, but the components can be scaled down.

The illuminating cone of light was provided by eight light-emitting diodes placed in 1.3 cm (1/2 in.) deep, 0.48 cm (3/16 in.) width slots milled at 45 degrees in a 3.17 cm (1-1/4 in.) inner-diameter cylinder. A second ring of eight LEDs was placed in a second milled slot, similar to the first, but 1.3 cm (1/2 in.) higher. In operation, the effect of turning on the upper ring simulates raising the head 1.3 cm (1/2 in.).

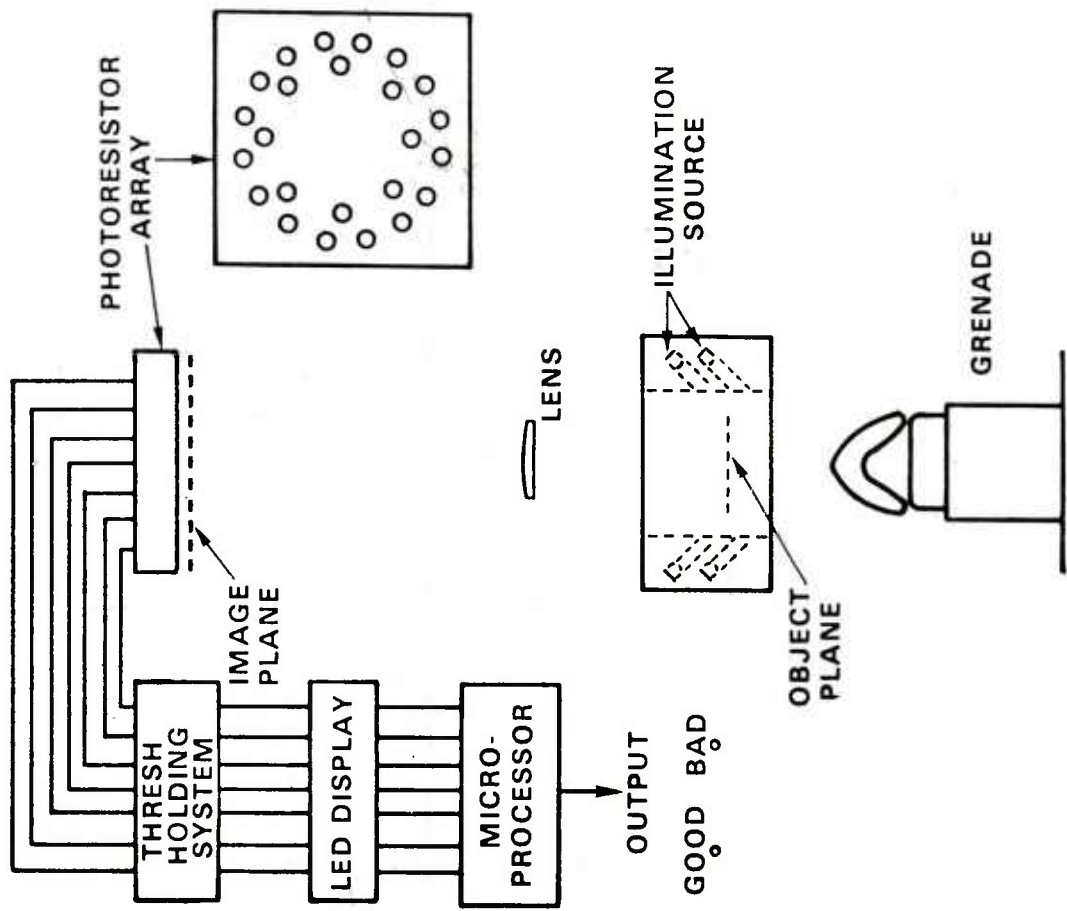

Figure 11. Experimental setup.

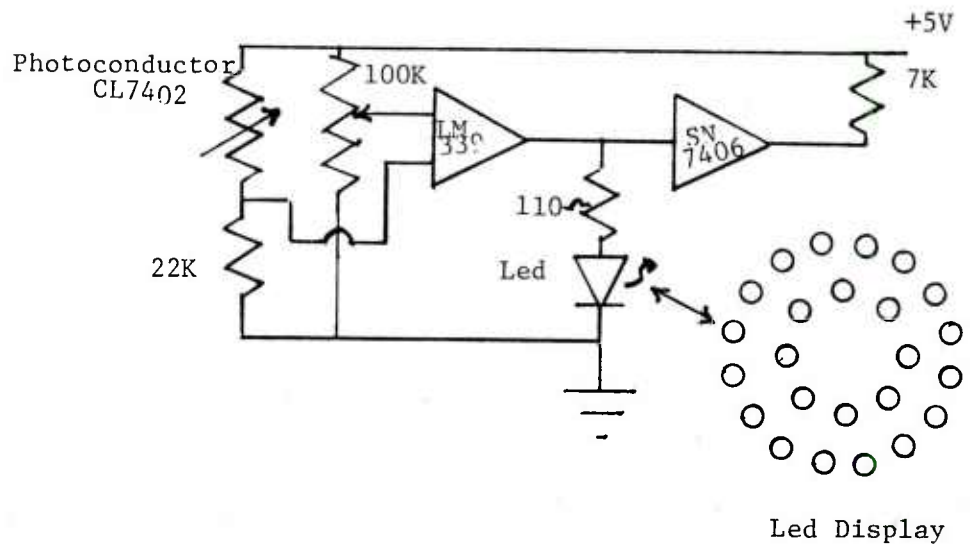

Figure 12. Schematic for one element of photoconductor ring.

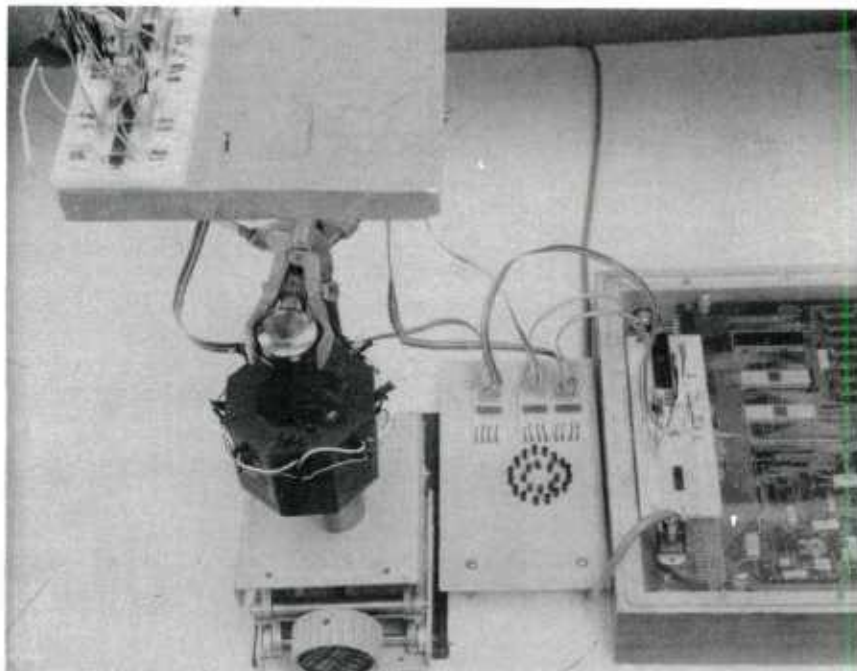

Figure 13. Lab setup - second approach.

Rather than lower the unit over the grenade, the grenade was raised into position by use of a lab-jack.

The lens was positioned to image the illuminated band falling on the grenade onto an array of photoresistors. Figure 14 shows the relationship of the grenade image to the photodetector array. Photoconductors were selected due to the ease with which they can be configured, their high sensitivity, and the simple electronic circuitry that can be used. The array consisted of 16 CL704L's in the outer ring; the inner ring was composed of 8 CL904L's. Each output was individually thresholded by the use of an LM339.

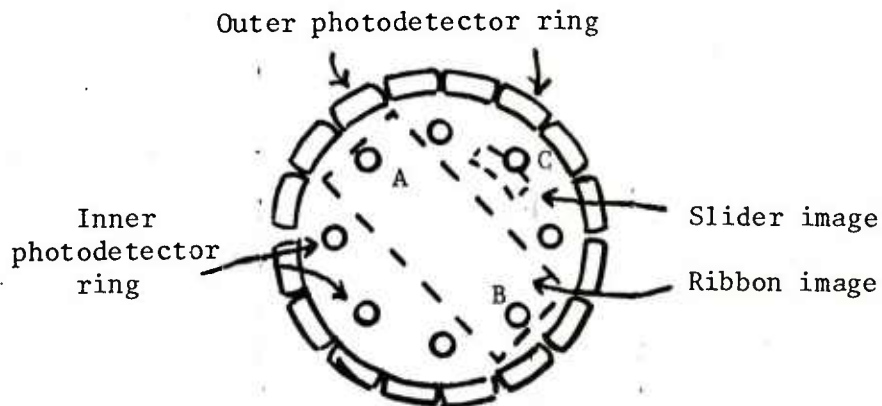

Figure 14. Photodetector array.

The outer ring diameter was selected to provide (in conjunction with the lens) an annular field of view of 3.8 cm (1-1/2 in.) diameter surrounding the grenade and the inner ring provided an annular field of view of 3.2 cm (1-1/4 in.) diameter at the plane of the grenade.

The 24 thresholded outputs were fed into a K1M-1 microcomputer for analysis.

An array of 24 LEDs was constructed to serve as a visual display to aid in programming the KIM. The array had a one-to-one relationship to the photoconductor array and demonstrated the effect of various ribbon configurations on the outputs.

DISCUSSION OF RESULTS

While the exact conditions under which the inspection system will be working are still undefined, the experimental investigation was conducted to cover the most stringent operating requirements. As a result, a rather sophisticated experimental inspection system was breadboarded. The fact is that the evolved demonstration system can always be simplified to meet better defined operating parameters.

During the course of this work, two distinctive approaches were developed. It became evident that if the grenade orientation were fixed, a simple inspection system based on proximity sensors would suffice. On the other hand, if grenade orientation were random, a sophisticated analysis need be performed: first, to determine the grenade orientation, and second, to determine if the grenades meet the definitions of proper packing.

Case I - Fixed Orientation

This is the simplest case for ribbon and slider inspection; only five optical proximity sensors are necessary to provide proper inspection. Figure 8 illustrates the basic configuration necessary to provide the inspection. In this configuration, the slider proximity sensor triggers an extension of the slider. Any output from the remaining sensors indicates an unfurling of the ribbon. By proper positioning of the sensors, displacement of the ribbon can be measured to any desired degree. By terminating the sensors in a fan configuration, the system can be made sensitive to minute shifts in the ribbon position.

Case II - Unknown Orientation

Figure 14 illustrates the photodetector array found necessary to perform this inspection and the position of the grenade image relative to the array. The inner ring of photodetectors has a radius such that the slider will be just imaged onto one of them

upon extension [1.5 cm (0.6 in.) from the central axis]. Unfortunately, the properly folded ribbon frequently will produce an output from the same ring, thus, a mechanism need be provided to distinguish the two sources of signal.

There are two means that are used to determine the source of the signal falling on the inner ring of photodetectors:

1. The slider reflects less light than the ribbon.

In order to detect the greater return of the ribbon, each photodetector in the inner ring has two threshold levels. When the higher level is exceeded, the ribbon is present. This feature alone will resolve the majority of cases except when the ribbon partially fills the detector's field of view.

2. The slider is at a 90 degree angle to the ribbon.

For this test it is necessary to determine the orientation of the ribbon. The location of the triggered output(s) is temporarily stored in the microprocessor memory. The cone of light is raised 1.3 cm (1/2 in.) illuminating the upper ribbon (fig. 7) where the image of the illuminated portion of the ribbon falls on the inner ring of photodetectors. The outputs of the inner ring are now used in the microprocessor to determine the ribbon orientation. Once the orientation is determined, the orientation of the signal (previously placed in memory) can be determined relative to the ribbon.

For example, for the grenade orientation shown in figure 14, high level outputs would be expected from photodetectors a and b. An output at the lower level from photodetector c, 90° from the ribbon, would be attributed to the extended slider.

Since the outer ring of photodetectors has a 3.8 cm (1-1/2 in.) diameter field of view around the grenade, any output during the inspection cycle from this ring will reject the grenade due to ribbon unfurling.

Figure 15 illustrates the logic flow chart used to perform the computer analysis.

The previous description covers the components required to inspect a single grenade. The difficult problem of fitting these components into the tight confines of the projectile still remains. Figure 16 illustrates a suggested configuration to inspect one grenade of the layer; eight of these would be nested together to provide inspection of the entire layer.

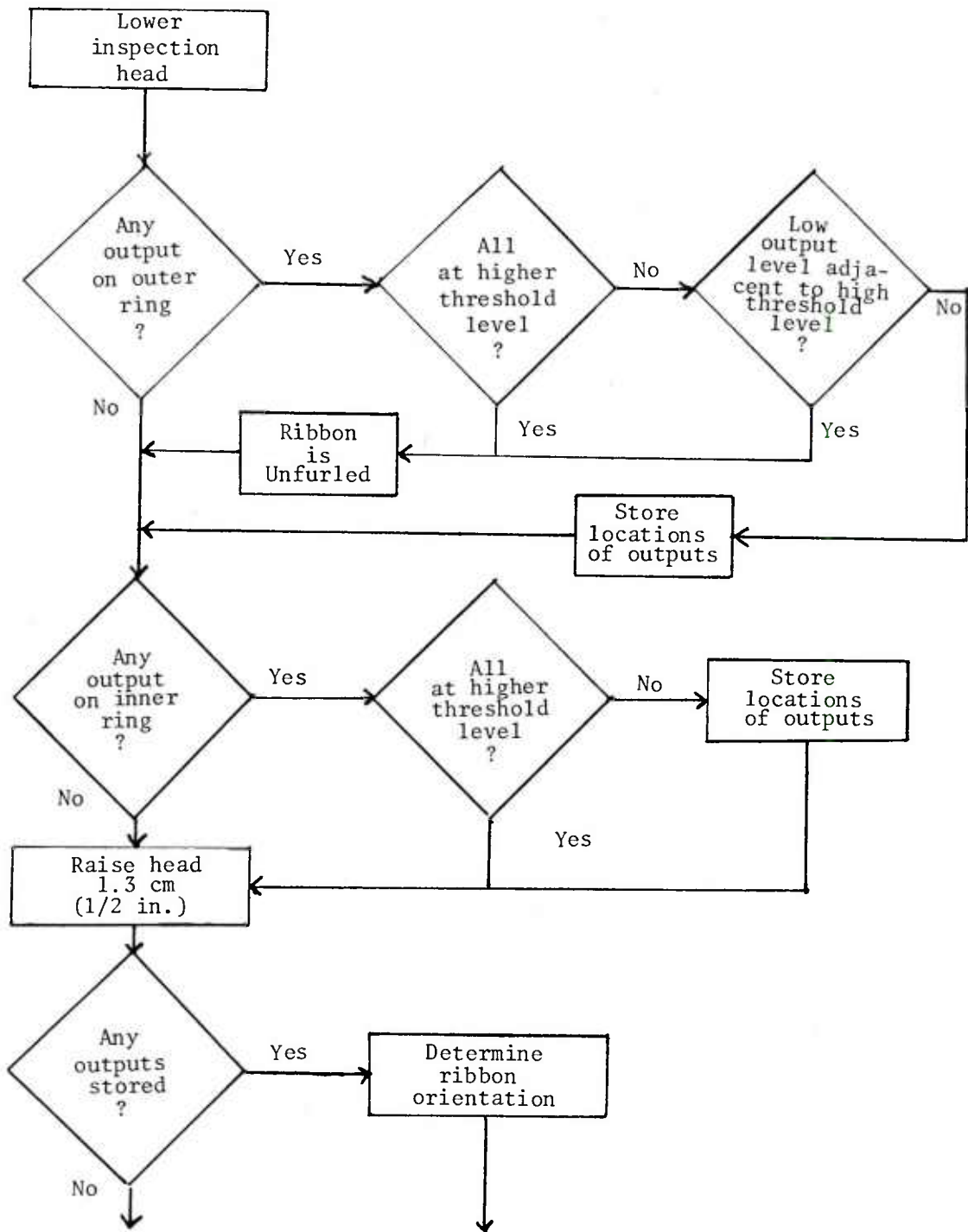

Figure 15. Logic flow chart diagram for use in grenade inspection.

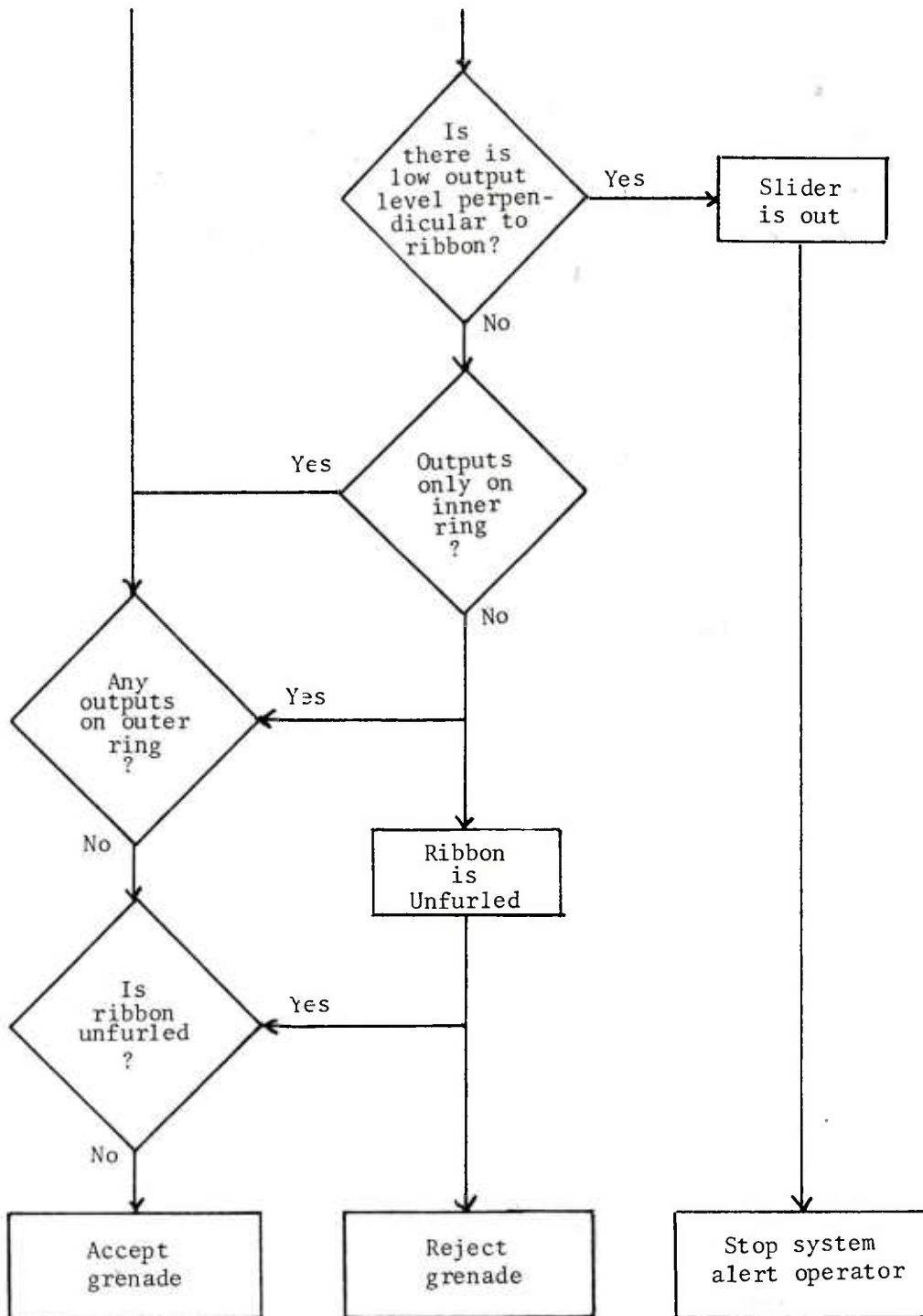

Figure 15. Logic flow chart diagram for use in grenade inspection (continued).

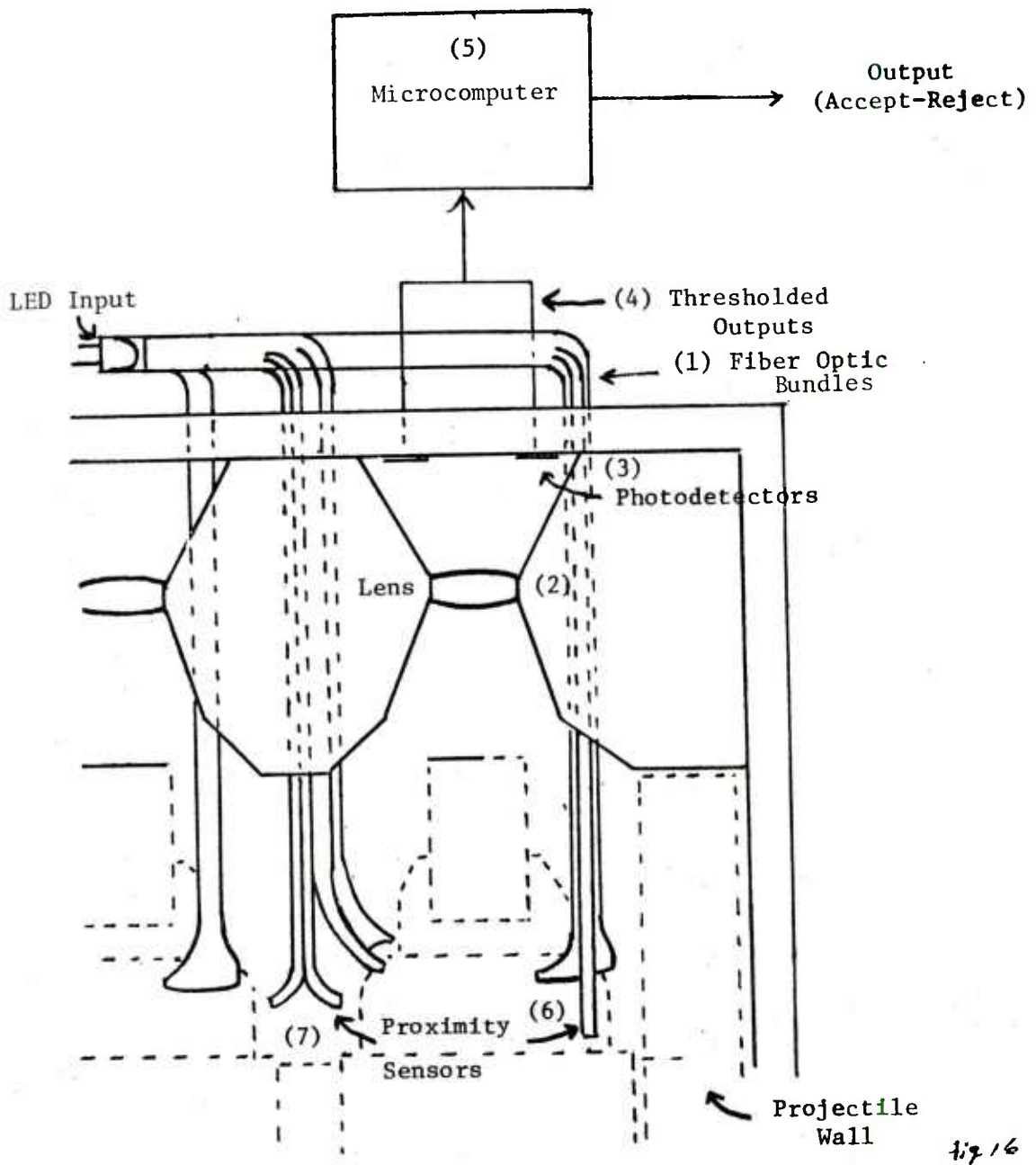

Figure 16. Suggested configuration for the optical inspection head.

DISTRIBUTION LIST

U.S. Army Munitions Production
Base Modernization Agency
U.S. Army Materiel Development and
Readiness Command
ATTN: SARPM-PBM-L (2)
SARPM-PBM-T
Dover, NJ 07801

Commander
U.S. Army Armament Research and
Development Command
ATTN: DRDAR-LCA
DRDAR-LCU
DRDAR-LCU-DS (2)
DRDAR-LCM
DRDAR-LCS
DRDAR-QAS (3)
DRDAR-LCA-PP, E. Kessler (11)
DRDAR-TSS (5)
Dover, NJ 07801

Project Manager for Selected Ammunition
U.S. Army Materiel Development and
Readiness Command
ATTN: DRCPM-SA-TD
Dover, NJ 07801

Commander
USA ARRCOM
ATTN: DRSAR-IM-L
DRSAR-QA
DRSAR-QA-EP (Dover Detachment)
Rock Island, IL 61299

Commander
Lone Star Army Ammunition Plant
ATTN: SARLS-EN
Texarkana, TX 57701

Commander
Kansas Army Ammunition Plant
ATTN: SARKA-EN
Parsons, KS 67537

Commander
Milan Army Ammunition Plant
ATTN: SARMA-EN
Milan, TN 38358

Director
Army Materials and Mechanics
Research Center
ATTN: DRXMR-PL (2)
DRXMR-M (2)
DRXMR-P
DRXMR-RA, Mr. Valente
DRXMR-MQ
DRXMR-MS, Mr. Darcy
DRXMR-L, Dr. Chait
Watertown, MA 02172

Defense Technical Information Center (12)
Cameron Station
Alexandria, VA 22314

Weapon Systems Concept Team/CSL
ATTN: DRDAR-ACW
Aberdeen Proving Ground, MD 21010

Technical Library
ATTN: DRDAR-CLJ-L
Aberdeen Proving Ground, MD 21010

Director
U.S. Army Ballistic Research Laboratory
ARRADCOM
ATTN: DRDAR-TSB-S
Aberdeen Proving Ground, MD 21005

Benet Weapons Laboratory
Technical Library
ATTN: DRDAR-LCU-TL
Watervliet, NY 12189

Commander
U.S. Army Armament Materiel
Readiness Command
ATTN: DRSAR-LEP-L
Rock Island, IL 61299

Director
U.S. Army TRADOC Systems
Analysis Activity
ATTN: ATAA-SL (Technical Library)
White Sands Missile Range, NM 88002

U.S. Army Materiel Systems
Analysis Activity
ATTN: DRXSJ-MP
Aberdeen Proving Ground, MD 21005