

AD-A088 886

MCDONNELL DOUGLAS ASTRONAUTICS CO-ST LOUIS MO
HOLE BURNING FILTER. CRYOGENIC COOLING FEASIBILITY STUDY.(U)
DEC 79 R D ROCHAT, J E JACKSON

F/G 1 /2

N00014-79-C-0641

NL

UNCLASSIFIED

1 of 1

AD-A088 886

AD-A088 886

AD-A088 886

AD-A088 886

AD-A088 886

AD-A088 886

AD-A088 886

AD-A088 886

AD-A088 886

AD-A088 886

AD-A088 886

AD-A088 886

AD-A088 886

AD-A088 886

AD-A088 886

AD-A088 886

AD-A088 886

AD-A088 886

AD-A088 886

AD-A088 886

AD-A088 886

AD-A088 886

AD-A088 886

AD-A088 886

AD-A088 886

AD-A088 886

AD-A088 886

AD-A088 886

AD-A088 886

AD-A088 886

AD-A088 886

AD-A088 886

AD-A088 886

AD-A088 886

AD-A088 886

AD-A088 886

AD-A088 886

AD-A088 886

AD-A088 886

AD-A088 886

AD-A088 886

AD-A088 886

AD-A088 886

AD-A088 886

AD-A088 886

AD-A088 886

AD-A088 886

AD-A088 886

AD-A088 886

AD-A088 886

AD-A088 886

AD-A088 886

AD-A088 886

AD-A088 886

AD-A088 886

AD-A088 886

AD-A088 886

AD-A088 886

AD-A088 886

AD-A088 886

AD-A088 886

AD-A088 886

END
DATE
FILMED
10 80
DTIC

AL A08886

LEVEL

220



HOLE BURNING FILTER CRYOGENIC COOLING FEASIBILITY STUDY

Contract N00014-79-C-0641

Issue date 15 December 1979 Contract number

Prepared by R. D. Rochat and J. E. Jackson

DTIC
ELECTE
SEP 8 1980
S C D

APPROVED FOR PUBLIC RELEASE
DISTRIBUTION UNLIMITED

MCDONNELL DOUGLAS ASTRONAUTICS COMPANY-ST. LOUIS DIVISION

Saint Louis, Missouri 63166 (314) 232-0232

MCDONNELL DOUGLAS CORPORATION

DDC FILE COPY.

80 9 3 009

(6)
HOLE BURNING FILTER,
CRYOGENIC COOLING FEASIBILITY STUDY

(11) 15 Dec 77

(9) FINAL REPORT

(13) 27

15 DECEMBER 1979

(15) N00014-77-3-0641

(10)
Prepared by: R. D. Rochat ~~and~~ J. E. Jackson

173130

elt

TABLE OF CONTENTS

SECTION		PAGE
	Table of Contents.	i
	List of Figures.	ii
1.0	INTRODUCTION	1
2.0	DESIGN CONDITIONS AND CONSTRAINTS.	2
3.0	BASELINE DESIGN.	3
4.0	THERMAL ANALYSIS	16
5.0	SUMMARY.	20

Accession For	
NTIS GRA&I	<input checked="" type="checkbox"/>
DDC TAB	<input type="checkbox"/>
Unannounced	<input type="checkbox"/>
Justification	
By _____	
Distribution/	
Availability Codes	
Dist	Avail and/or special
A	

LIST OF FIGURES

FIGURE	TITLE	PAGE
3.1	Refrigeration System Concept.	4
3.2	Carnot Coefficient of Performance	5
3.3	Mass of Low Temperature Refrigerators	6
3.4	Volume of Low Temperature Refrigerators	7
3.5	Efficiency of Low Temperature Refrigerators	8
3.6	Filter Containment.	9
3.7	Containment Support Structure	11
3.8	Thermal Conductivity: Stainless Steel 303.	12
3.9	Effect of Number of Windows on Heat Leak and Optical Transmission.	13
3.10	Optical Properties of Induced Transmission Filter	14
4.1	Filter Containment Thermal Model.	17
4.2	Sensitivity of Refrigerator Power to Cooler Stage Temperatures.	18
5.1	Filter Containment System Performance Summary	22

1.0 INTRODUCTION

The Hole Burning Filter Receiver is an attractive filter concept for utilization in a strategic laser communications system for submerged submarines. The feasibility of this approach depends upon the ability to maintain the filter at cryogenic (64°K) temperatures. This final report submits an evaluation of a cryogenic cooling system for the hole burning filter including estimates of size, weight, and power.

2.0 DESIGN CONDITIONS AND CONSTRAINTS

Certain performance requirements and environmental conditions used for this study are postulated below.

2.1 PERFORMANCE REQUIREMENTS

The filter unit is assumed to be a single one-meter diameter by one-inch thick unit viewing optical windows from each face. The transmission through the optical path consisting of the windows but excluding the filter must be greater than 50 percent at $0.5 \mu\text{m}$. It is assumed that the internal heat load in the filter is negligible and that only heat leaks into the system from the environment are pertinent.

The cryogenic system was to be designed in a manner such as to minimize the cooler system power consumption, and that the filter is to be maintained in an active state 100 percent of the time.

2.2 ENVIRONMENTAL CONSTRAINTS

For this study, the system was assumed to be in a one-atmosphere compartment with an infinite sink temperature of 20°C . The filter containment system was designed to survive 5 g loads in all axes.

3.0 BASELINE DESIGN

3.1 CRYOGENIC REFRIGERATION SYSTEM

A three-stage Claude system with helium working fluid, shown in Figure 3.1, was selected as the refrigeration system. This type system is capable of achieving liquid helium temperatures in the range of 4°K. The helium compressor supplies fluid to a Joule-Thomson valve for expansion to achieve the necessary low temperature sink. The three heat exchangers in the flow path are used to subcool the helium to achieve a low working fluid temperature upstream of the joule-Thomson valve. Some helium is taken off at each heat exchanger stage to cool different levels within the filter containment insulation system. This is done to improve the heat removal effectiveness. As shown in Figure 3.2, the coefficient of performance for a refrigerator ($COPR = \frac{TC}{TH-TC}$) for a Carnot cycle is nearly proportional to the refrigeration temperature (TC) for very low temperatures with a constant hot side (TH) sink temperature. It is an obvious power advantage to remove as much heat as practical at the higher temperature stages.

Detail analysis and design of a cryogenic refrigeration system is beyond the scope and not required for this feasibility study. Parametric data taken from Reference (1) is used to characterize refrigerator size, weight, and thermal performance. Figures 3.3 and 3.4 show refrigerator system mass and volume for 4-9°K refrigerators as a function of low temperature cooling capacity. Figure 3.5 shows the coefficient of performance (COPR) as a percent of Carnot effectiveness for 4-9°K refrigerators as a function of the low temperature heat load.

3.2 CONTAINMENT SYSTEM

The containment system was designed to interface with the three-stage Claude refrigerator and to provide maximum resistance heat flow paths to the environment. A concentric three-barrel arrangement shown in Figure 3.6 was selected. This concept consists of the three-concentric shells with conductive insulation and multiple windows on each side of the filter to minimize the system heat leak. To further reduce the radial heat leak, the containment system shells are supported from each adjacent external shell by three equally space separator structures. These support structures are staggered circumferential about the shells, as shown in Figure 3.6. This provides greater resistance to heat flow by adding

FIGURE 3

REFRIGERATION SYSTEM CONCEPT

- 3 STAGE CLAUDE CYCLE
- HELIUM WORKING FLUID

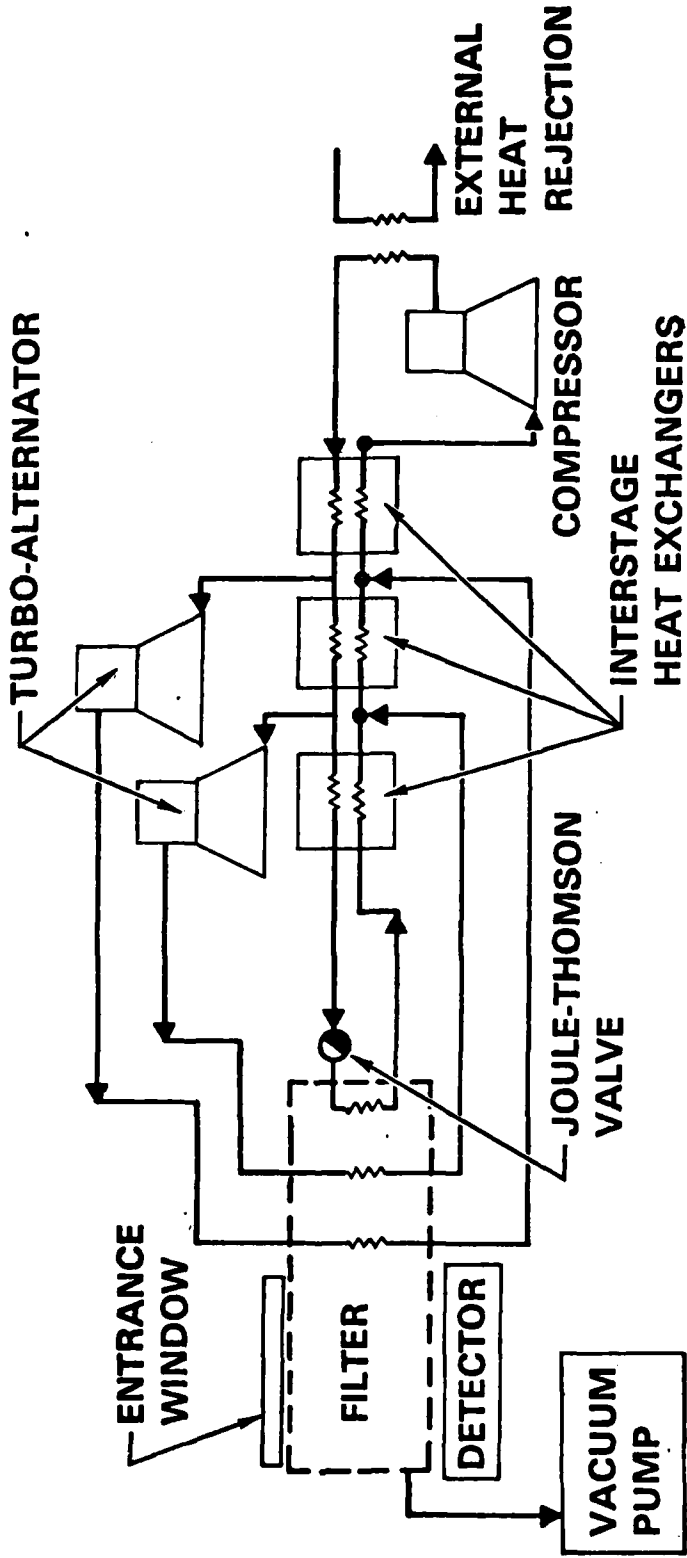

Fig 3.2

CARNOT COEFFICIENT OF PERFORMANCE

$$\text{COPR} = \frac{T_C}{T_H - T_C} \quad \begin{array}{l} T_C = \text{COLD SIDE} \\ T_H = \text{HOT SIDE} = 20^\circ\text{C} \end{array}$$

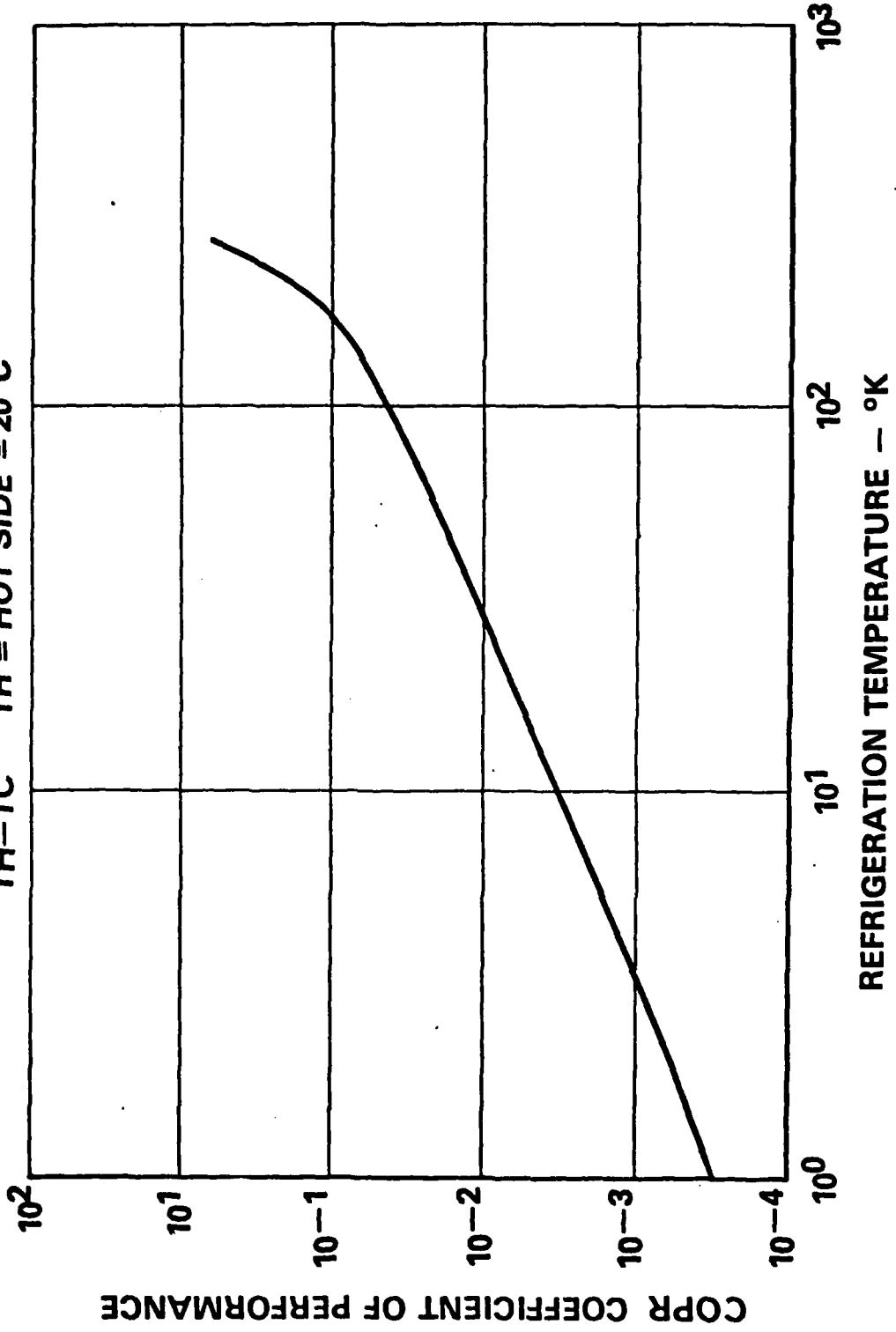

FIGURE 3

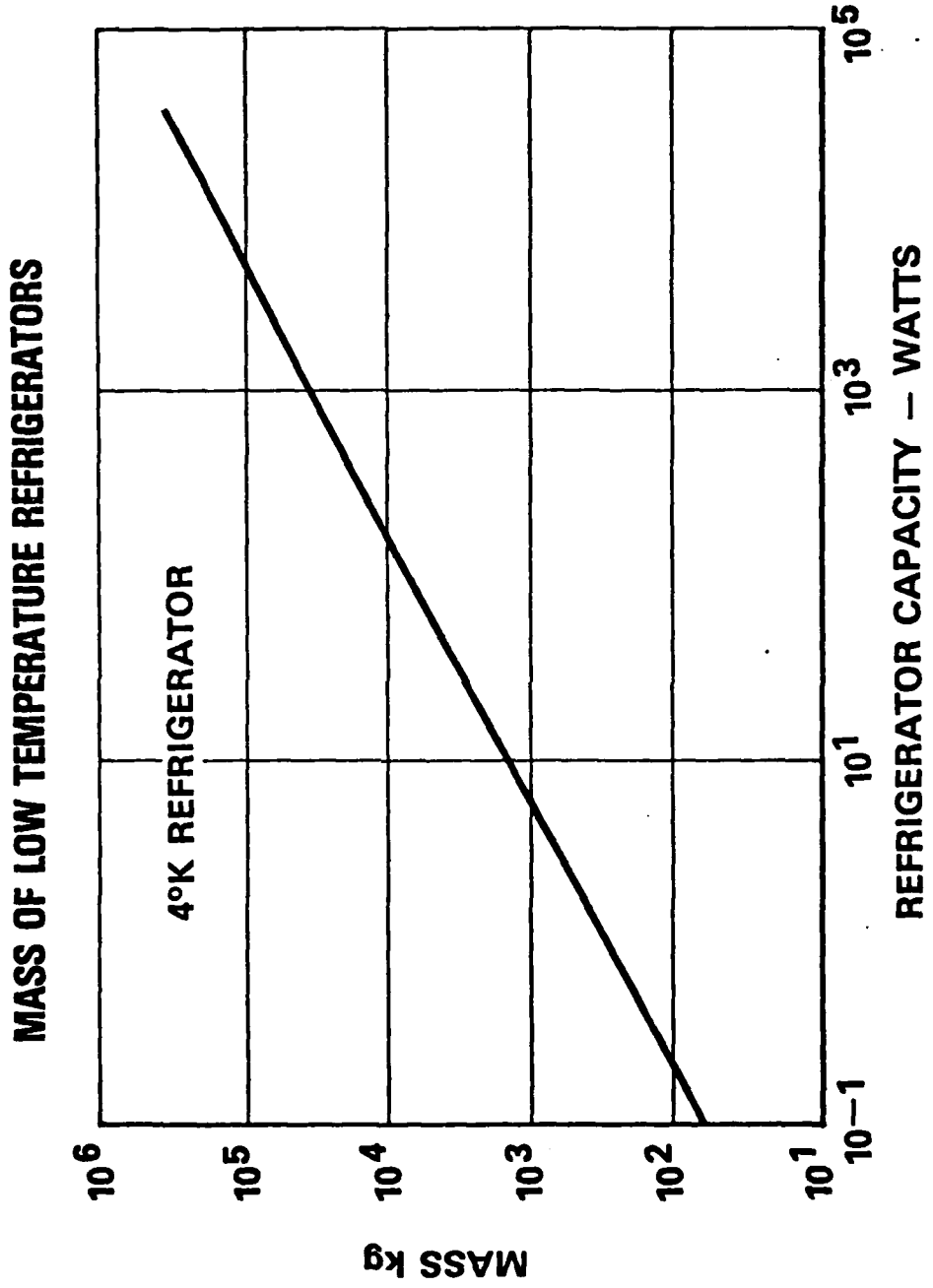
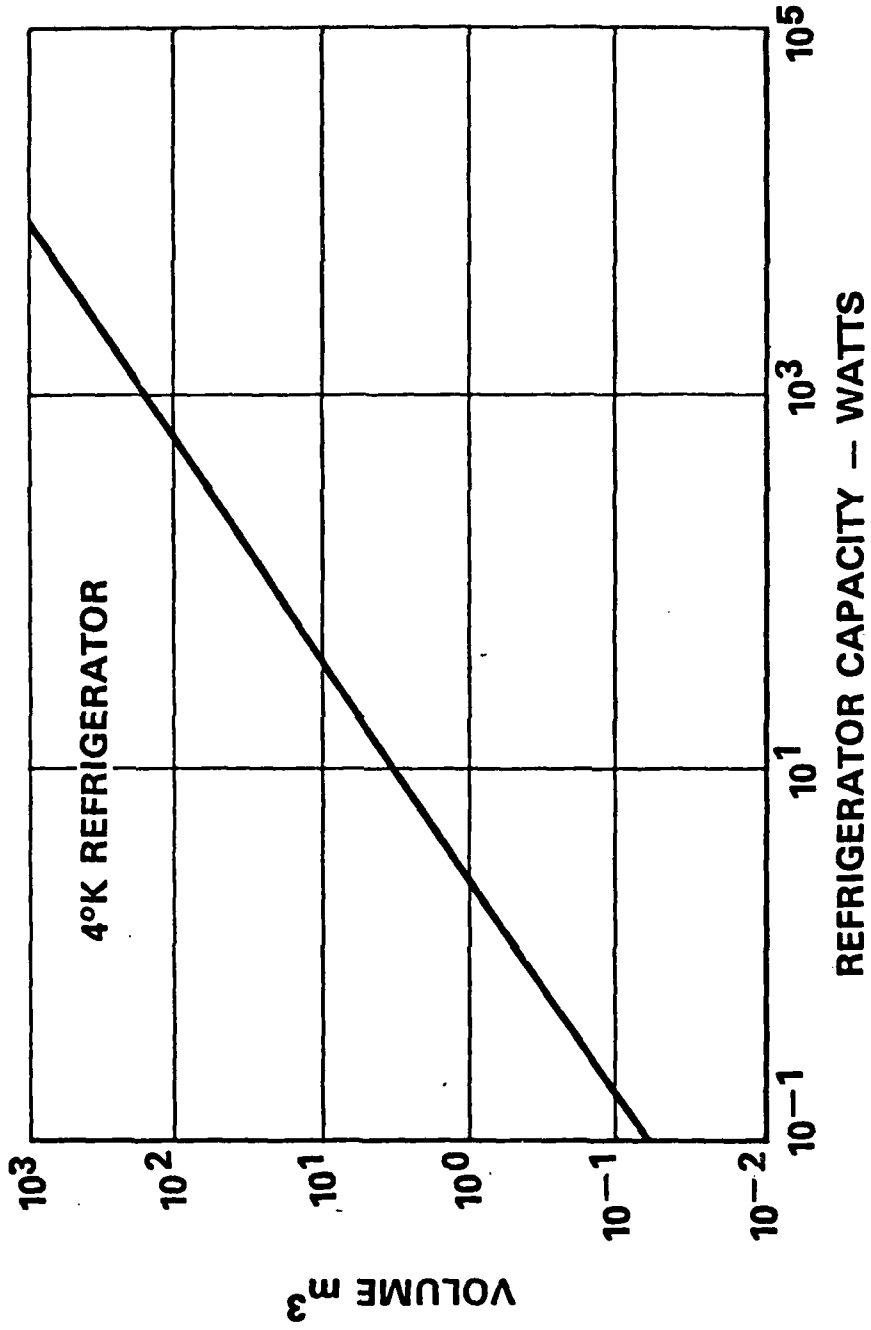
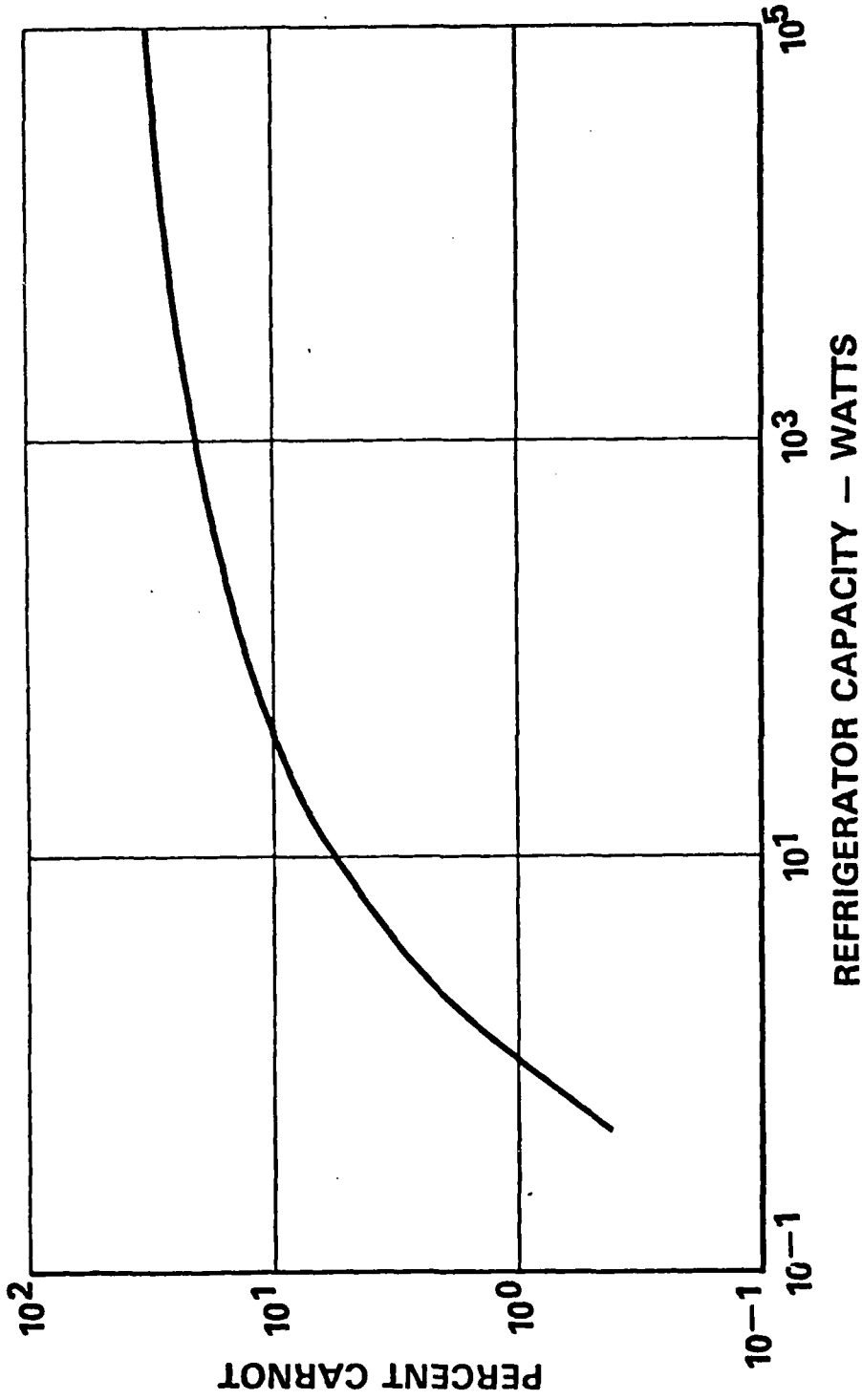

FIGURE 3.4

VOLUME OF LOW TEMPERATURE REFRIGERATORS



EFFICIENCY OF LOW TEMPERATURE REFRIGERATORS



FILTER CONTAINMENT

SEC A--A SYMMETRICAL ABOUT FILTER

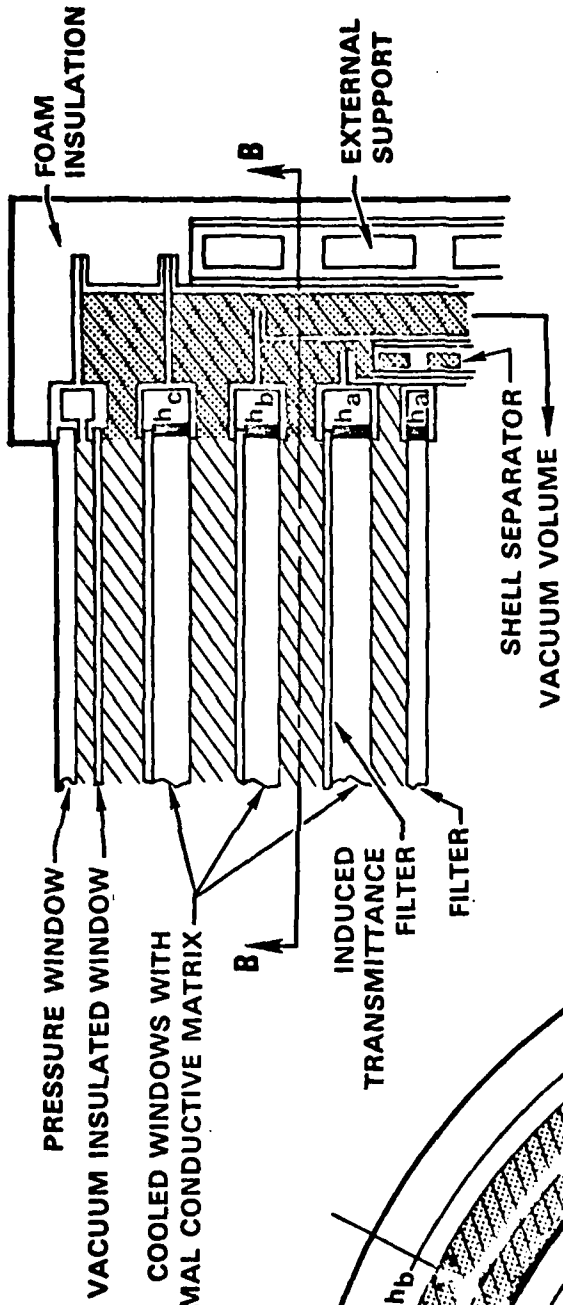

SEC B--B

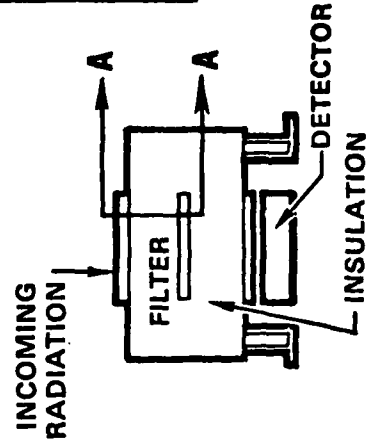
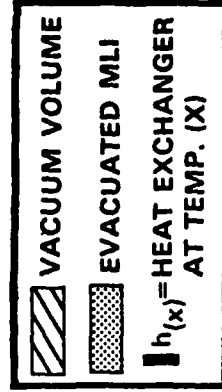
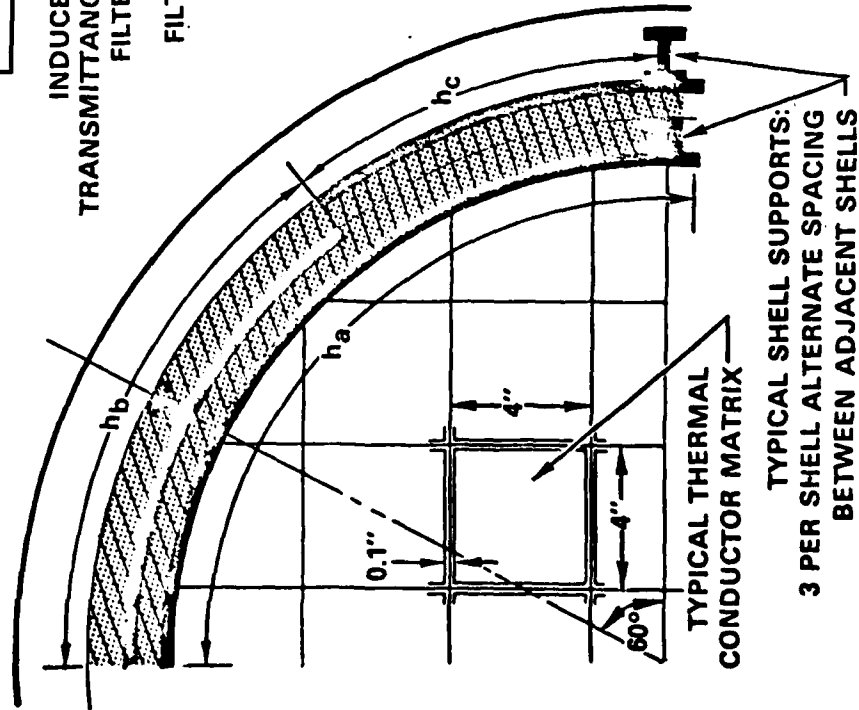

the barrel resistance to the heat path between adjacent separator structures. The containment system is externally supported by three support beams. These beams and the internal separator structures are two-inch I-beam members with web material removed, as shown in Figure 3.7 to reduce thermal conductance. The shell structure and I-beam support structures were sized to survive 5-g loadings in all three axes.

Thermal insulating materials were postulated for use in the containment system design to minimize the radial heat leaks. The exterior of the containment system was assumed insulated with two inches of low-density foam having a thermal conductivity of 0.02 Btu/Hr-Ft-°F in 1 atm. Two inches of a multilayer insulation (MLI) is assumed between adjacent shells. It is also assumed that all the internal volume of the containment system is pumped down and maintained at vacuum conditions. In this condition, MLI is an extremely good thermal insulator having a thermal conductivity of less than 2×10^{-5} Btu/Hr-Ft-°F. The support structures and concentric shells are stainless steel. Stainless steel is a common structural material for utilization at cryogenic temperatures, and as shown in Figure 3.8 is a good insulator at very cold temperatures (Reference (2)).

The optical path is insulated by the use of multiple IR absorptive windows. As noted in Section 2.1, however, the optical path must have a transmission of greater than 50 percent at 0.5 μ m. This constraint limits the total number of windows that can be utilized in the optical path. Figure 3.9 shows the estimated heat leak and 0.5 μ m transmission as a function of the number of windows. This calculation assumes the use of an induced transmission filter (ITF) (with optical properties given in Figure 3.10) in the optical path on each side of the cryogenic filter. The heat leak and transmission are both inversely proportional to the total number of windows. However, to achieve a transmission of no less than 50 percent, no more than 10 windows can be used. The insert in Figure 3.6 shows the typical filter window design incorporating 5 windows on each side of the filter. Again, it is noted that the volume inside the outer window is maintained at a vacuum to minimize convective heat transfer between windows.

CONTAINMENT SUPPORT STRUCTURE

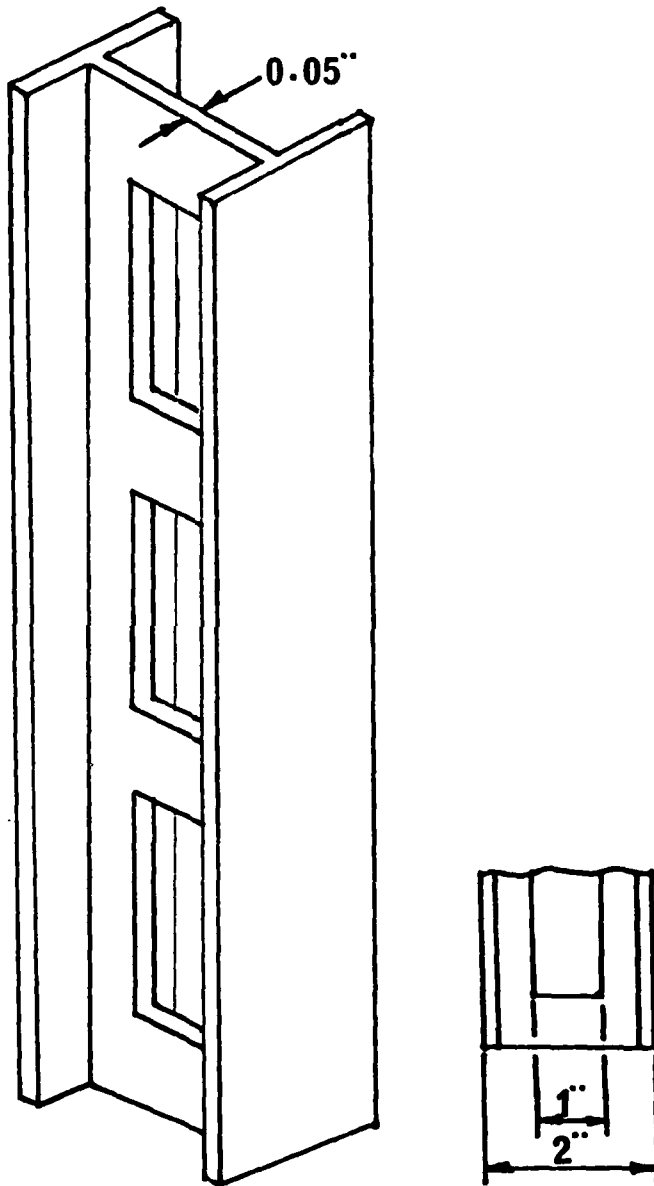

Figure 3.8

THERMAL CONDUCTIVITY STAINLESS STEEL 303

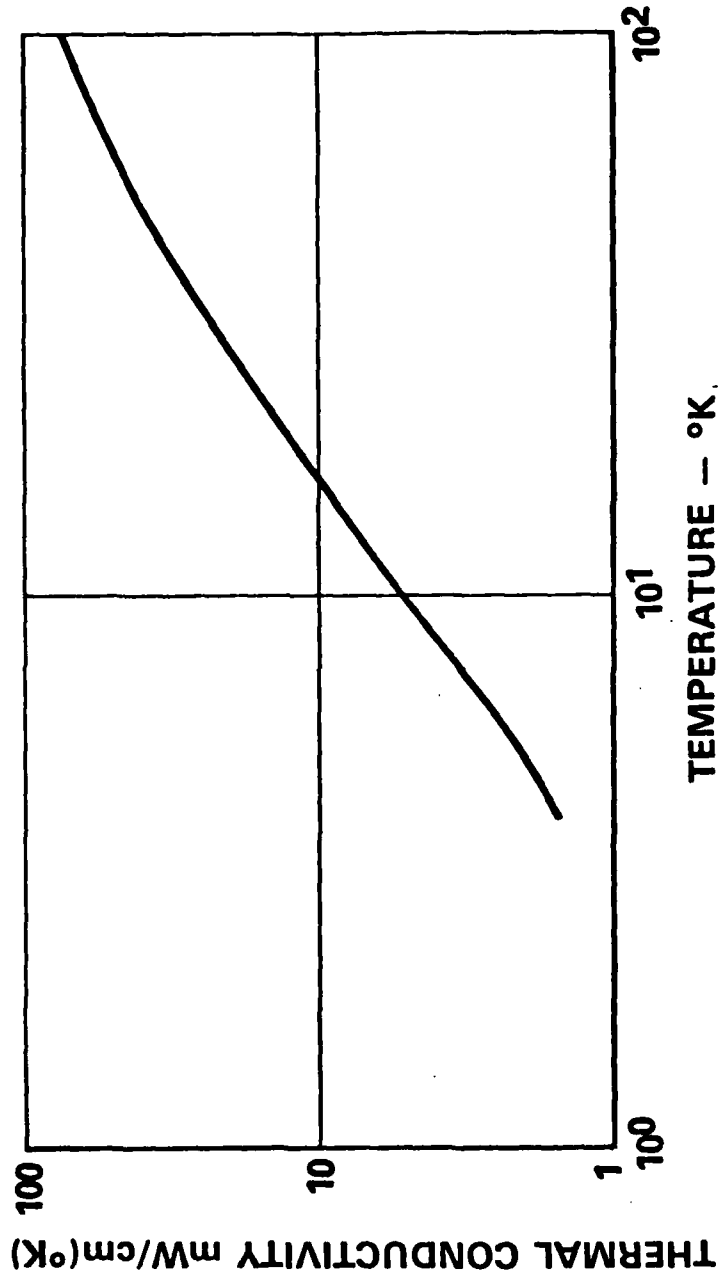

FIGURE 9

EFFECT OF NUMBER OF WINDOWS ON HEAT LEAK AND OPTICAL TRANSMISSION

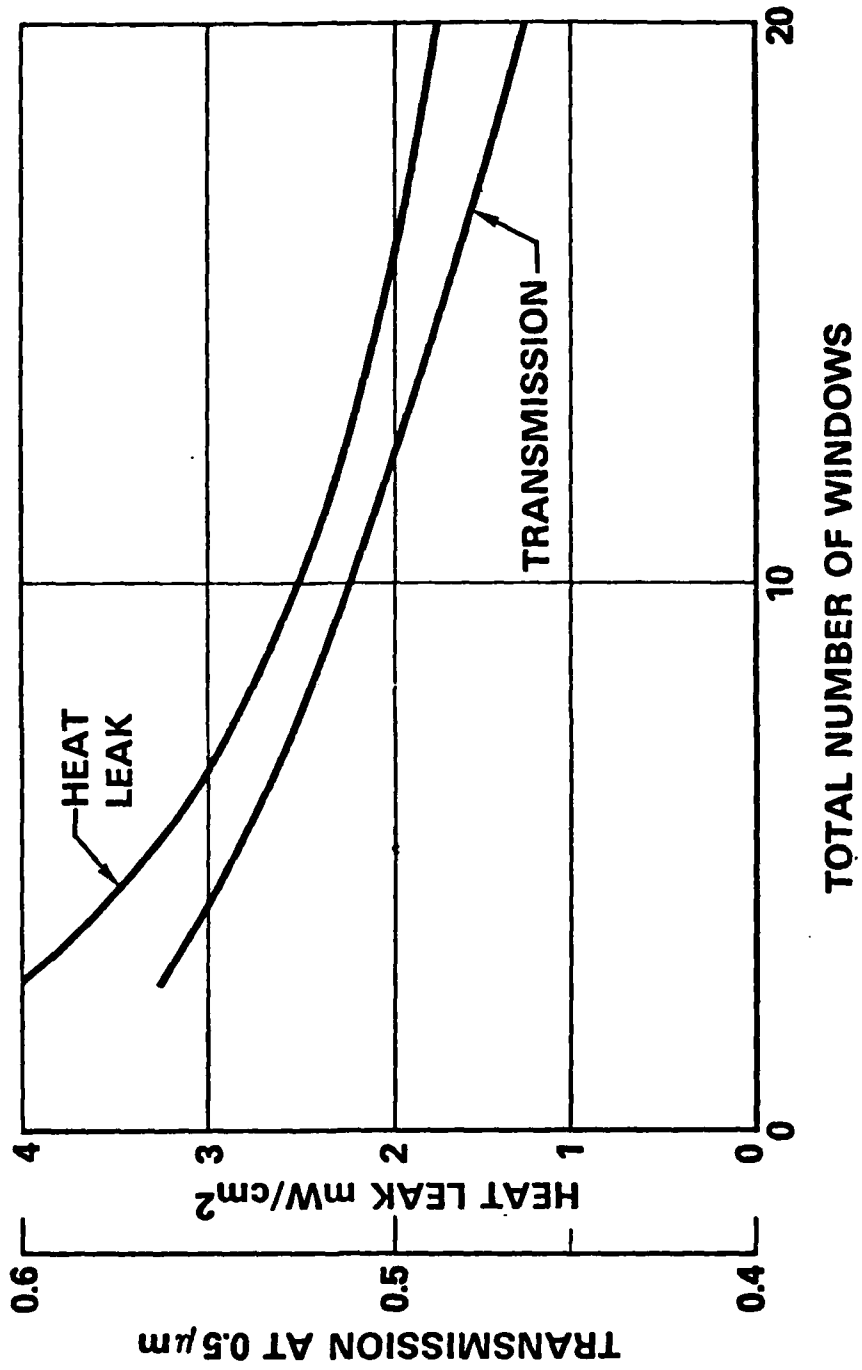
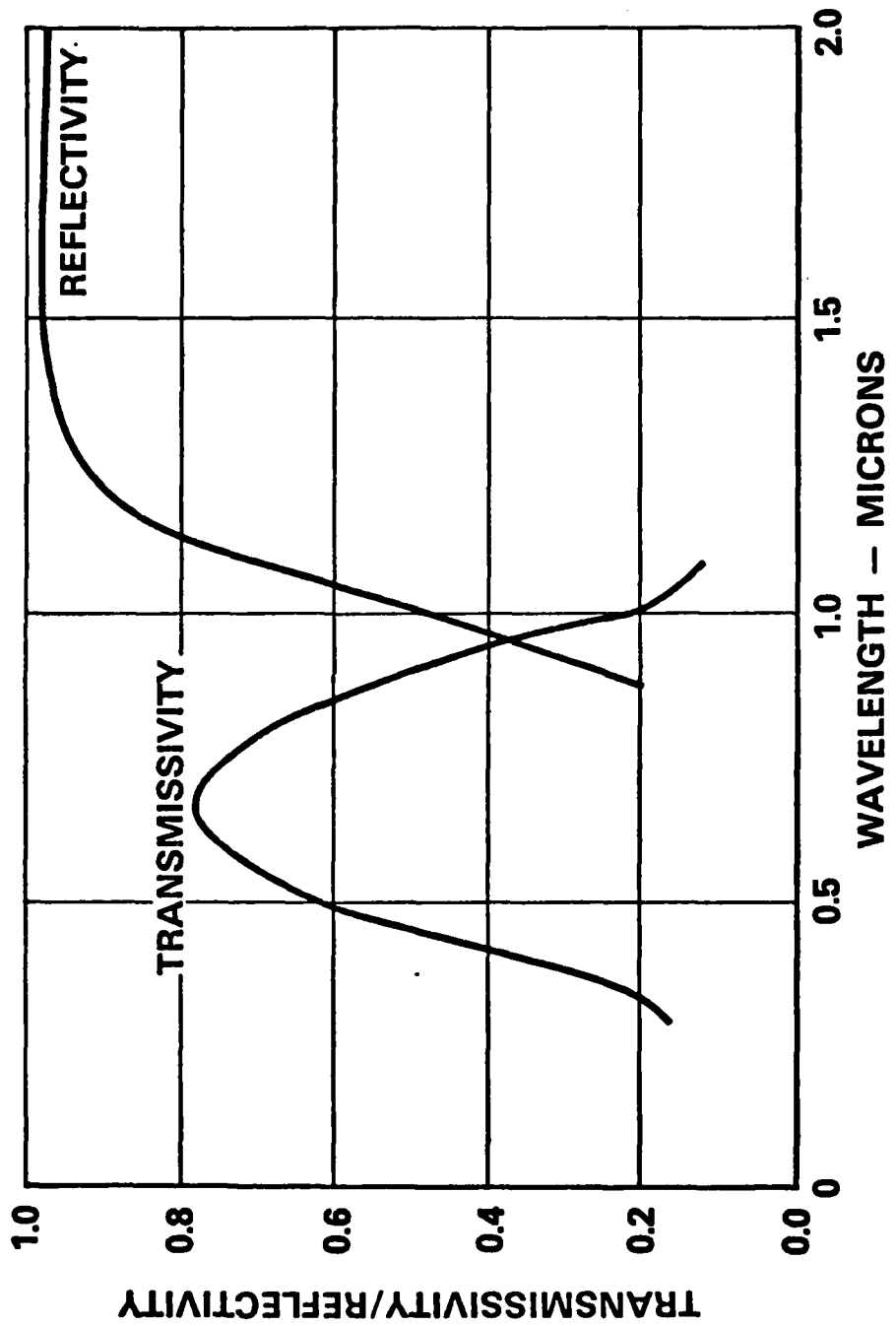

FIGURE 5.10

OPTICAL PROPERTIES OF INDUCED TRANSMISSION FILTER



The containment system has three cooling stages as defined by the three Claude refrigerator stages, see Figure 3.6. The filter, inner window, and inner shell are cooled to 4°K by the exit helium from the cooling system Joule-Thomson valve. The middle shell and second most inner window are cooled by the second stage helium bleed off. The outer shell and the third most inner window are cooled by the refrigerator first stage. The two outer most windows are not actively cooled. The shells, windows, and filter are cooled by circumferential heat exchangers. Window isothermalization is provided by a stainless steel grid work mounted behind each window pane, see Figure 3.6.

4.0 THERMAL ANALYSIS

A thermal analysis using a 16-node containment system thermal model was performed to determine the overall containment system heat leaks. With the calculated heat leak, the overall refrigerator system size, weight, and power can be estimated using Figures 3.3, 3.4, and 3.5. The containment system weight was estimated from the design postulated in Section 3.0.

A sixteen-node thermal model was set up to simulate the heat transfer performance of the filter containment system. The system was assumed to be symmetrical about the filter and only one-half of the system was modeled. A schematic of the thermal model resistive network is shown in Figure 4.1, and a description of the thermal nodes is given below:

NODES	DESCRIPTION
1-6	Barrels: 2/barrel
7-11	Windows: 1/window
12	Filter
13-16	Isothermal grid: 1/grid

The thermal model consists of conductive heat transfer through the structural elements of the containment system and radiation between adjacent windows. Convection heat transfer is assumed external to the system but neglected internally due to the vacuum conditions. The thermal conductivity of the materials are assumed to be a function of temperature, from Reference (2). The heat loads from the ambient act on the system as convective and radiative heat inputs from an infinite sink at 20°C. The cooling for the system by the refrigeration unit acts on the model through interface heat exchanges having 90 percent heat exchanger effectiveness.

The refrigerator power needed to maintain the filter at 4°K is a function of the selected refrigerator stage temperatures. Figure 4.2 shows the power requirements for various cooler stage temperatures. An optimum set of stage temperatures exists because of the influences of:

1. COPR of each stage as a function of temperature
2. Conductivity as a function of temperature
3. Variable heat transfer between adjacent shells or windows

FILTER CONTAINMENT THERMAL MODEL

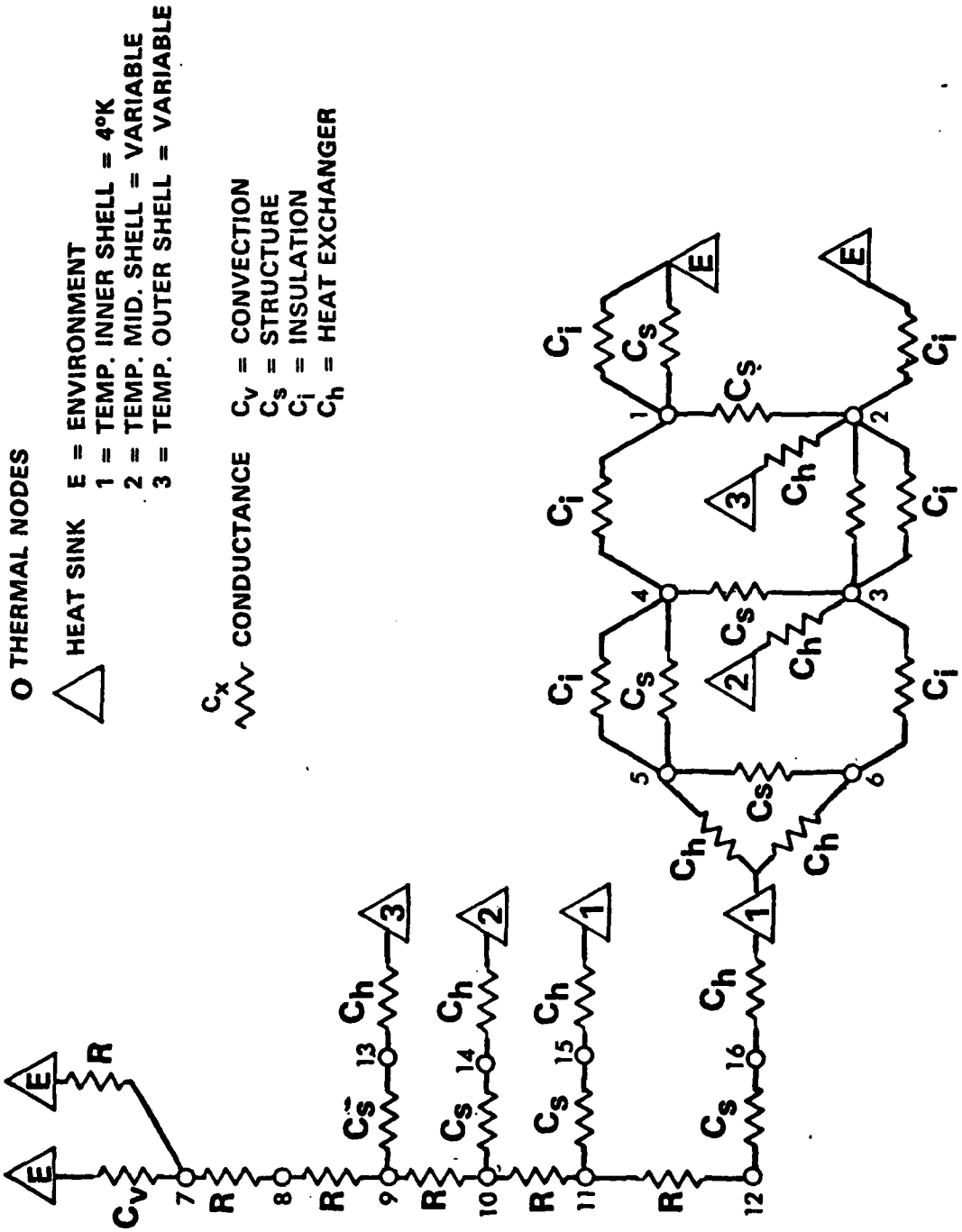
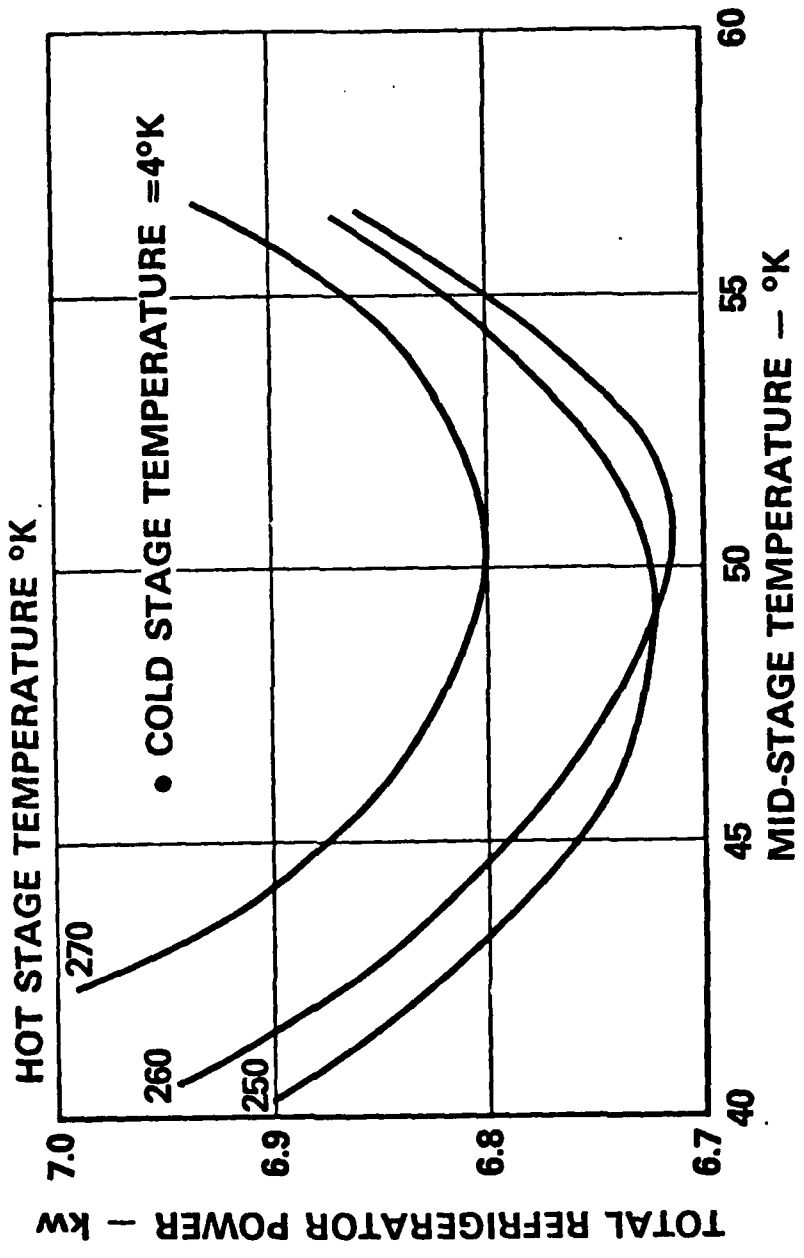

FIGURE 4.

SENSITIVITY OF REFRIGERATOR POWER TO COOLER STAGE TEMPERATURES



For this analysis the optimum stage temperatures are:

1. Inner shell = 4°K (*fixed*)
2. Middle shell = 51°K
3. Outer shell = 260°K

5.0 SUMMARY

Figure 5.1 presents the postulated hole burning filter cooling system performance summary for the optimum case as determined in Section 4.0. The largest heat leak into the system is through the external insulation and support structure into the outer structural shell. This heat load can be efficiently removed however, at the hot stage temperature as noted from the allocation of refrigerator power. The most significant driver of refrigerator power is the heat leak into the 4°K hole burning filter area through the optical windows. Minimization of this heat leak is difficult due to the optical transmission requirement in the optical path.

This feasibility study was conducted considering a single hole burning filter unit with a 100 percent active duty cycle. If the filter receiver were designed to consist of a number of smaller units with a combined filter area equal to the one discussed in this study, increases in size, weight, and power would be expected since the area of the containment walls would increase. In addition the heat conduction path length through the side walls decreases resulting in a greater heat leak.

Operationally, it may be possible for the receiver to be periodically shut off by allowing shutters to close off the window access to the outside greatly lowering the heat leak and enabling a decrease in the cooling power requirements. Also initial cool down of the system would be greatly facilitated by having this shuttering capability.

The present feasibility study has attempted to design a cryogenically cooled containment system that would minimize the power requirements. The size and weight of the required cryogenic refrigerator system have been extrapolated from data on typical cryogenic refrigerator systems available. With specific design detail to the requirements of this task and employing minimal spacecraft technologies a smaller and lighter weight could be achieved.

A new Trident submarine will weigh about 17.3 E6 kg with the 25 ft high sail weighing 25,174 kg. The estimated weight of the refrigerator and containment system for the hole burning filter receiver is 1310 kg which is less than 0.01%

of the total submarine weight and only 5.2% of the sail weight wherein it would be mounted. It is hard to visualize that weight would be a driving design factor in the submarine receiver. Also, the power would not overtax the capability of the submarine Nuclear Power plant even with all other systems turned on. Consequently, a decision to initiate research and development of the hole burning filter receiver should be based on issues other than the size, weight, and power requirements of the cryogenic refrigerator and the hole burning filter containment system.

FIGURE 5.1
 FILTER CONTAINMENT SYSTEM PERFORMANCE SUMMARY

HEAT LEAK/POWER SUMMARY

HEAT SINK	HEAT LEAK, WATTS	REFRIGERATOR POWER, WATTS
Containment Shells		
Cold Stage, 4°K	0.7	950
Mid Stage, 51°K	22.0	2090
Hot Stage, 260°K	74.0	155
Optical Windows		
Cold Stage, 4°K	2.2	3010
Mid Stage, 51°K	5.2	490
Hot Stage, 260°K	2.0	5
TOTAL	106.1	6700

CONFIGURATION SUMMARY

	REFRIGERATOR	CONTAINMENT
Power	6.7 kW	--
Size	1.4 m ³	0.8 m ³
Weight	860 kg	450 kg

REFERENCES

1. Strobridge, T.R., Cryogenic Refrigerators an Update Survey NBS Technical Note 655, June 1974.
2. Powell, R. L. and Blanpied, W. A., Thermal Conductivity of Metals at Low Temperature, NBS Circular 556, 1 September 1954.