

AD-A088 939

HUMAN ENGINEERING LAB ABERDEEN PROVING GROUND MD F/6 9 1
USERS MANUAL FOR THE TRANSPARENT TOUCH SENSITIVE CATHODE RAY TU-- TC(U)
JUL 80 M W THOMPSON
HEL-TN-8-80

UNCLASSIFIED

NL

1-1
AD
A-88-13



END
DATE
FILMED
10 80
DTIC

LEVEL

13^{ES}

AD

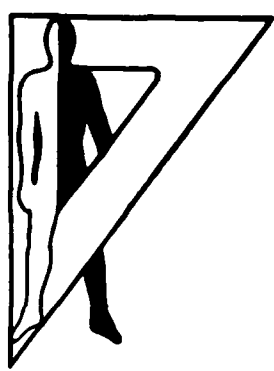

Technical Note 8-80

**USERS MANUAL FOR THE TRANSPARENT TOUCH SENSITIVE
CATHODE RAY TUBE DISPLAY OVERLAY**

Michael W. Thompson

**DTIC
SELECTED
SEP 9 1980**

AD A 088939

July 1980
AMCMS Code 612716.H700011

Approved for public release,
distribution unlimited.

FILE COPY

U. S. ARMY HUMAN ENGINEERING LABORATORY

Aberdeen Proving Ground, Maryland

80 9 4 005

**Destroy this report when no longer needed.
Do not return it to the originator.**

**The findings in this report are not to be construed as an official Department
of the Army position unless so designated by other authorized documents.**

**Use of trade names in this report does not constitute an official endorsement
or approval of the use of such commercial products.**

14/HIL-TN-8-80

SECURITY CLASSIFICATION OF THIS PAGE (When Data Entered)

REPORT DOCUMENTATION PAGE		READ INSTRUCTIONS BEFORE COMPLETING FORM
1. REPORT NUMBER Technical Note 8-80 ✓	2. GOVT ACCESSION NO. AD-A088939 (9)	3. RECIPIENT'S CATALOG NUMBER
4. TITLE (and Subtitle) 6 USERS MANUAL FOR THE TRANSPARENT TOUCH SENSITIVE CATHODE RAY TUBE DISPLAY OVERLAY	5. TYPE OF REPORT & PERIOD COVERED Final rept.	
7. AUTHOR(s) 10 Michael W. Thompson	8. CONTRACT OR GRANT NUMBER(s)	
9. PERFORMING ORGANIZATION NAME AND ADDRESS US Army Human Engineering Laboratory ✓ Aberdeen Proving Ground, MD 21005	10. PROGRAM ELEMENT, PROJECT, TASK AREA & WORK UNIT NUMBERS AMCMS Code 612716.H700011	
11. CONTROLLING OFFICE NAME AND ADDRESS	11	12. REPORT DATE July 1980
14. MONITORING AGENCY NAME & ADDRESS (if different from Controlling Office) 12 18	13. NUMBER OF PAGES 15	
16. DISTRIBUTION STATEMENT (of this Report) Approved for public release; distribution unlimited.		15. SECURITY CLASS. (of this report) UNCLASSIFIED
17. DISTRIBUTION STATEMENT (of the abstract entered in Block 20, if different from Report)		15a. DECLASSIFICATION/DOWNGRADING SCHEDULE
18. SUPPLEMENTARY NOTES		
19. KEY WORDS (Continue on reverse side if necessary and identify by block number) Interactive Graphics Command Control Communications C3 Touch Sensitive		
20. ABSTRACT (Continue on reverse side if necessary and identify by block number) This manual provides the operational and programming information for using the Elographics Touch Sensor on the Varian 620 computer. The touch sensor is a transparent pressure sensitive panel that overlays a graphics display system CRT. The touch sensor also consists of a Touch Sensor Controller and an Interface Controller for configuring the touch sensor to the Varian 620 computer. Programming is accomplished using the Varian DAS assembly language.		

DTIC
SELECTED
SEP 9 1980
D

DD FORM 1 JAN 73 1473

EDITION OF 1 NOV 65 IS OBSOLETE

SECURITY CLASSIFICATION OF THIS PAGE (When Data Entered)

172850

USERS MANUAL FOR THE TRANSPARENT TOUCH SENSITIVE
CATHODE RAY TUBE DISPLAY OVERLAY

Michael W. Thompson

July 1980

APPROVED:

John D. Weisz

JOHN D. WEISZ
Director

U.S. Army Human Engineering Laboratory

U. S. ARMY HUMAN ENGINEERING LABORATORY
Aberdeen Proving Ground, Maryland 21005

Approved for public release,
distribution unlimited.

Accession For	
NTIS GFA&I	
DDC TAB	
Unannounced	
Justification	
By _____	
Distribution/	
Availability Codes	
Dist	Avail and/or special
A	

CONTENTS

INTRODUCTION	3
GENERAL DESCRIPTION	3
DETAILED DESCRIPTION	3
THEORY OF OPERATION	6
DATA ACCEPTED	11
USING THE TOUCH SENSOR	11
APPENDIX	
Instruction Set	13
FIGURES	
1. Position of Contact Points	4
2. Touch Sensor Configuration	5
3. Block Diagram Touch Sensor and Touch Sensor Controller	7
4. Block Diagram Interface Controller	9

USERS MANUAL FOR THE TRANSPARENT TOUCH SENSITIVE
CATHODE RAY TUBE DISPLAY OVERLAY

INTRODUCTION

The Elographics E270 Transparent Touch Sensor has been acquired for use on the Command/Control Simulator. An Interface Controller has been designed and built by the US Army Human Engineering Laboratory (USAHEL) for configuring the Touch Sensor to the Varian 620 computer. This manual provides the operational and programming information for using the Touch Sensor on the Varian 620 computer. The user should be familiar with the Varian computer and the DAS assembly language programming to fully understand the information in this manual. For additional information on the Varian 620 computer refer to the Varian 620 100's Computer Handbook.

GENERAL DESCRIPTION

The Touch Sensor is a transparent pressure sensitive panel designed to form fit the IDIOM graphics display system cathode ray tube (CRT). The Touch Sensor, along with the Touch Sensor Controller and the Interface Controller, provide an active area on the display surface that responds to the touch when under program control. Information displayed on the CRT can be manipulated by simple finger touch action on the CRT surface. The Touch Sensor has nearly infinite resolution but is limited to 1023x1023 areas by the analog-to-digital converters of the Touch Sensor controller (Figure 1).

DETAILED DESCRIPTION

The Touch Sensor consists of three elements when configured to the Varian computer. These are the Touch Sensor, the Touch Sensor Controller, and the Interface Controller. All of these elements when installed and operating in the computer system require no operator action other than programming the Varian computer for specialized use of the Touch Sensor (Figure 2).

Touch Sensor

The Touch Sensor is a transparent pressure sensitive panel that responds to the touch when under program control. Affixed to the IDIOM display CRT, the Touch Sensor is made of a glass sheet, coated with a transparent resistive layer on one side. This is covered by a plastic cover sheet, coated with a transparent conductive layer on the side facing the resistive layer. Pressure applied to the plastic cover sheet causes the resistive and the conductive layers to contact which results in a

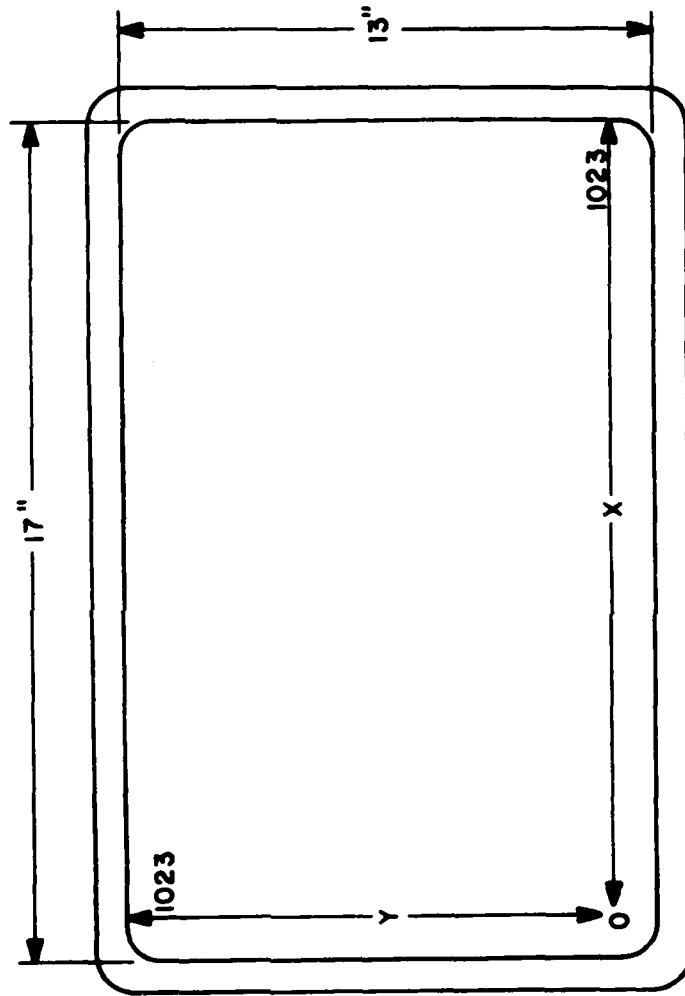

Figure 1. Position of contact points.

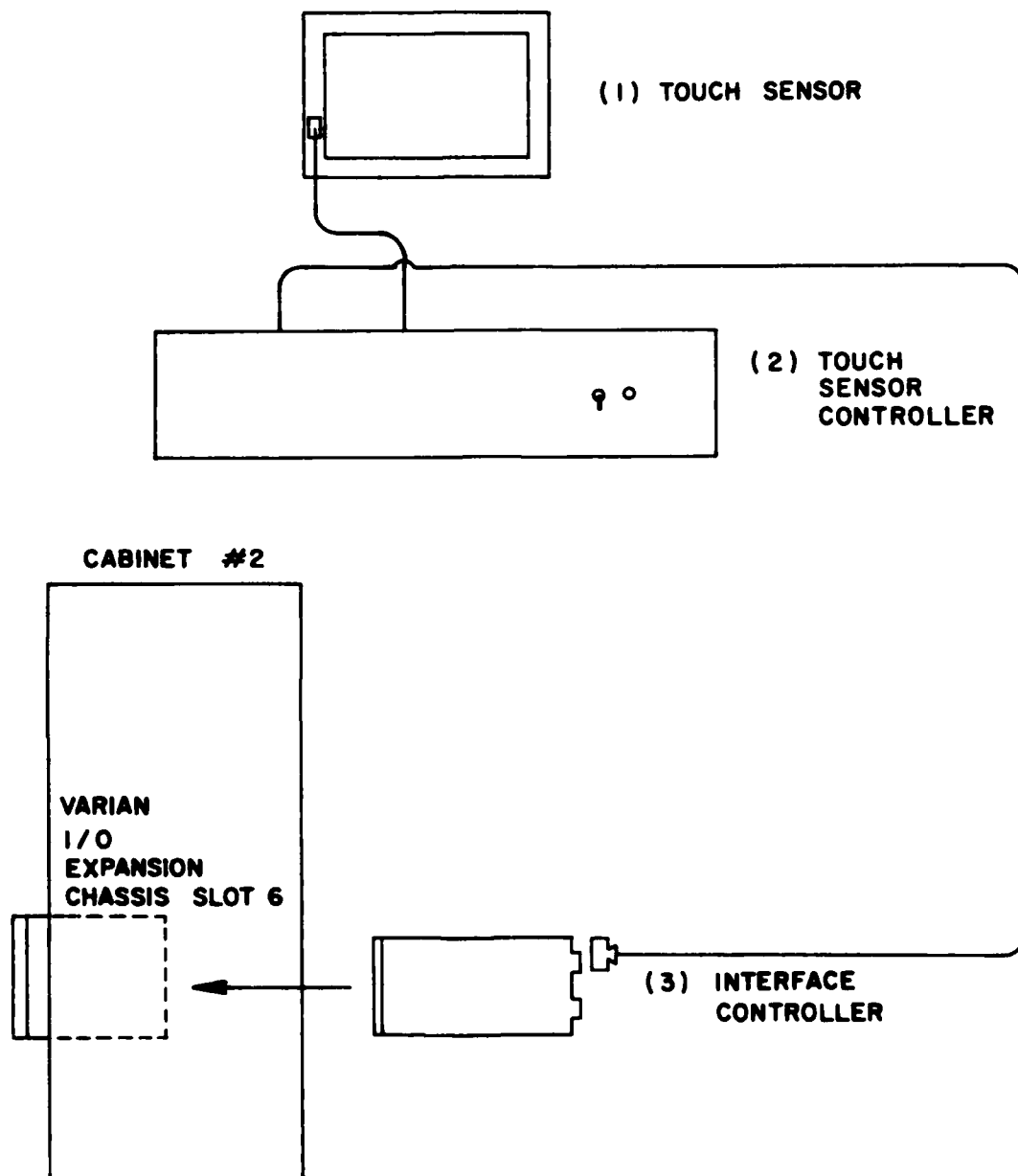

Figure 2. Touch sensor configuration.

contact point being generated. The Touch Sensor uses an X and Y addressing system and is arranged to provide 1023x1023 resolvable areas. Figure 1 shows the resolvable area arrangement of the X and Y axes on the Touch Sensor. Once touch down, due to finger pressure, is detected, two analog voltage levels are generated representing the X and Y coordinates of the touched area.

Touch Sensor Controller

The Touch Sensor Controller supplies the voltages for the X and Y axes on the Touch Sensor and digitizes the analog voltage levels generated by the Touch Sensor at the point of contact. The controller provides two operational modes; a single point mode that digitizes the analog voltage levels every time the Touch Sensor is touched and released, and a stream mode that digitizes at a 60-hertz rate as long as contact on the Touch Sensor is maintained. Once the analog voltages are digitized, they are ready for transfer in the form of two 10-bit parallel outputs representing the X and Y coordinates in binary form. The Touch Sensor Controller electronics are contained in a mounting chassis which fits in a 19" relay rack.

Interface Controller

The Interface Controller contains all the logic necessary for program control of the Touch Sensor on the Varian 620 computer. Located in the I/O expansion chassis on a Varian wire wrap board, the Interface Controller provides the data link between the computer and the Touch Sensor. Assigned a unique device address of 74, the Interface Controller allows DAS formatted instructions to be recognized, thus enabling program control of the Touch Sensor by address decoding, instruction decoding, device sensing, and data transferring between the Touch Sensor and the computer.

THEORY OF OPERATION

Analog Data Generation

A voltage is alternately applied to the X and Y axes on the resistive layer on the Touch Sensor. Finger pressure, applied at a point on the plastic cover sheet, causes the conductive layer to contact the resistive layer. This generates two voltage levels forming the X and Y coordinates in the form of analog voltage levels, one for the X axis and one for the Y axis. These analog voltage levels (analog data) are picked up by a sense line and applied to the Touch Sensor Controller (Figure 3).

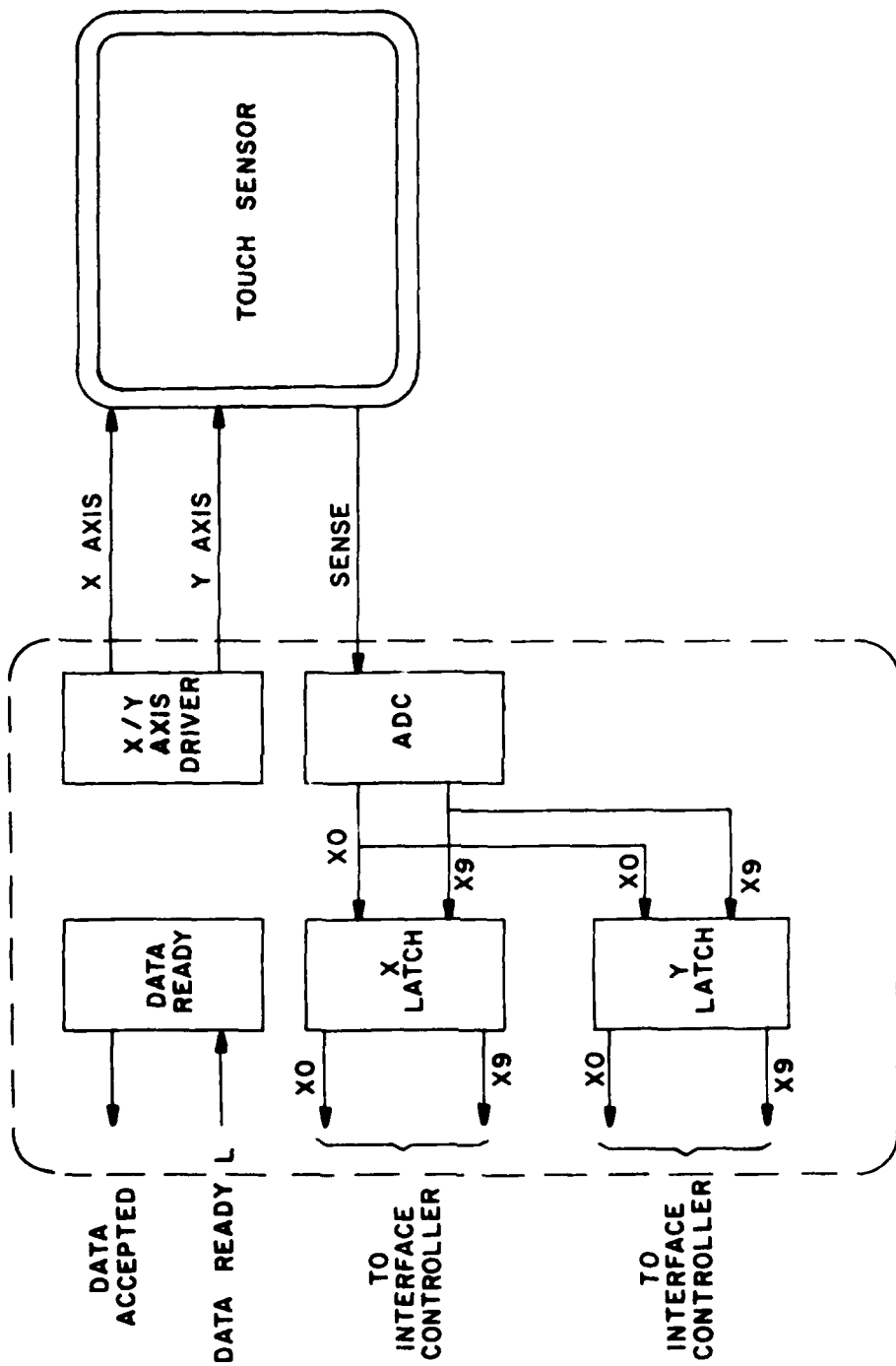

Figure 3. Block diagram touch sensor and touch sensor controller.

Analog to Digital Conversion

The analog voltage levels are applied to the Analog to Digital Converter (ADC) located in the Touch Sensor Controller. The ADC samples the analog voltage levels and then converts them into 10-bit binary numerical values, one for the X axis and the other one for the Y axis coordinate addresses. These values can range from 0 to 1023 depending upon the point of contact on the Touch Sensor. Once the X and Y values are determined, they are temporarily stored in two 10-bit registers called the X and Y Latch Registers and a DATA READY L signal is generated to the Interface Controller signifying that data is available (Figure 3).

X Register

The X Register is a 10-bit temporary storage register located in the interface controller for containing the binary numerical coordinate of the X axis prior to it being placed on the E-Bus to the computer. When DATA READY L is received from the Touch Sensor Controller, the data from the X Latch Register is buffered through the line receivers and placed in the X Register in the Interface Controller (Figure 4).

Y Register

The Y Register is a 10-bit temporary storage register located in the interface controller for containing the binary numerical coordinate of the Y axis prior to it being placed on the E-Bus to the computer. When DATA READY L is received from the Touch Sensor Controller, the data from the Y Latch Register is buffered through the line receivers and placed in the Y Register in the Interface Controller (Figure 4). Data is now in the X and Y Registers representing the point of contact on the Touch Sensor and awaiting computer action. Further action is performed according to a sequence of computer program instructions.

EXC Instruction Decoding

An EXC instruction enables one of the following functions at the controller interface. Select X Register (SELX), Select Y Register (SELY), Select Stream Mode (STREAM), or RESET. The execution of an external control (EXC) instruction places the FRYX-I control line true, which indicates that an EXC instruction and a device address have been placed on the E-Bus. The Instruction Decode logic is enabled when E-Bus lines EB06 through EB08 and EB11 is decoded and provides the SEL 0,1,2,3, output. Generation of the device address, DA74, strobes the decoded function into the appropriate flip-flop (FF) to latch the selected function.

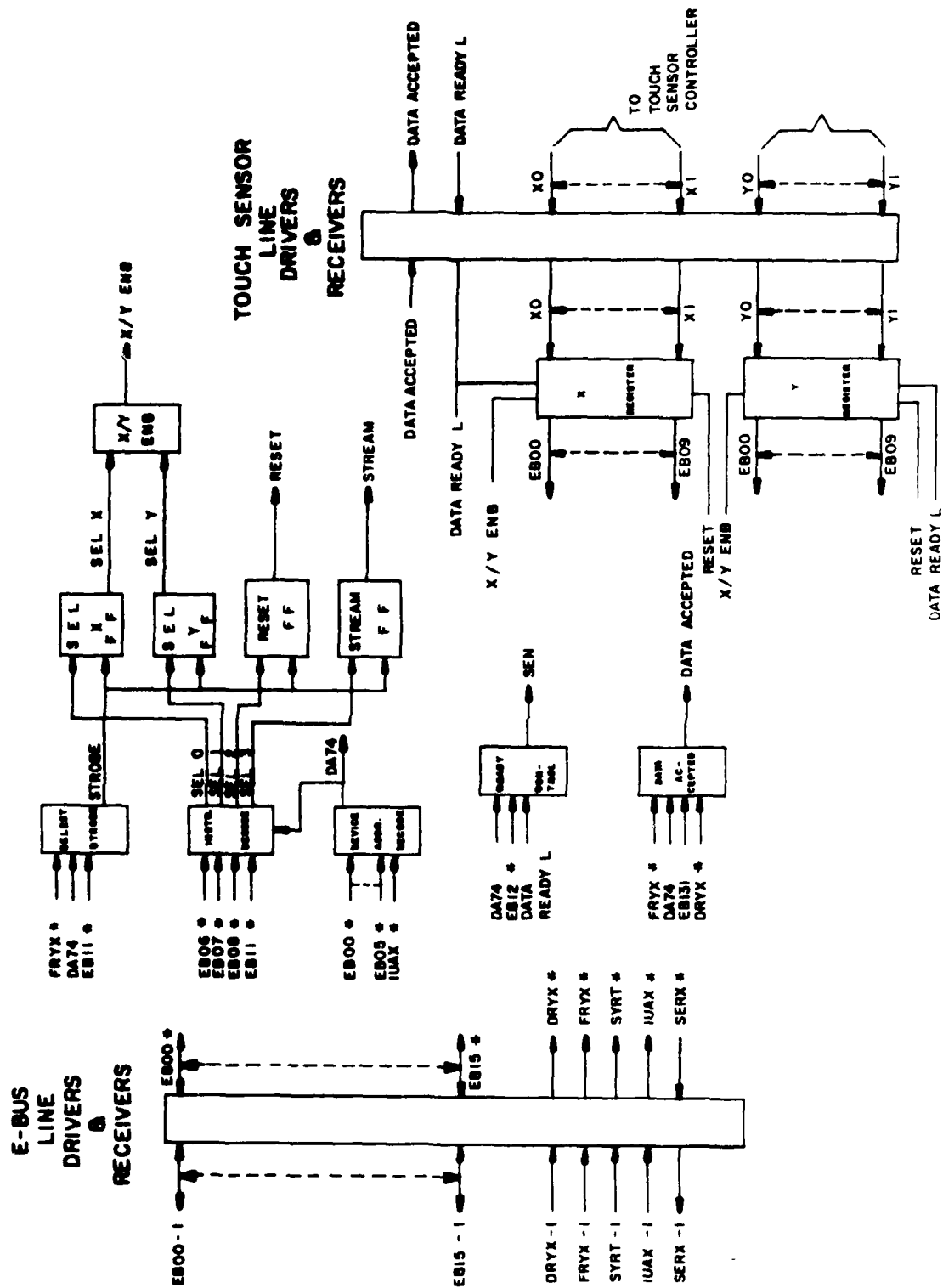

Figure 4. Block diagram interface controller.

Device Address Decode

The execution of any I/O instruction causes a device address to be placed on the E-Bus line. When E-Bus lines (EB) EB00 through EB05 equals the device address assigned to the Touch Sensor (74) and no interrupts are being processed, as signified by IUAX-I line being false, the device address decode logic generates the signal DA74, indicating the Touch Sensor is requested (Figure 4).

Ready Control

When the SEN instruction is executed, a function code and device address are placed on the E-Bus lines. When the device address is decoded (see Device Address Decode) and DATA READY L signal is true (see Analog to Digital Conversion), the Interface Controller responds to the SEN instruction by setting the SERX-I line true, which signifies to the computer that data is available in the X and Y Registers (Figure 4).

EXC 0074 (Select X Register)

The Varian DAS instruction EXC 0074 causes a function code of 0 to be placed on the E-Bus lines EB06 through EB08 and results in setting the SEL X FF. This results in the signal SEL X going true, placing the data in the X Register onto the E-Bus for computer action (Figure 4).

EXC 0174 (Select Y Register)

The Varian DAS instruction EXC 0174 causes a function code of 1 to be placed on the E-Bus lines EB06 through EB08 and results in setting the SEL Y FF. This results in the signal SEL Y going true, placing the data in the Y Register onto the E-Bus for computer action (Figure 4).

EXC 0274 (Programmed Reset)

The Varian DAS instruction EXC 0274 causes a function code of 2 to be placed on the E-Bus lines EB06 through EB08 and results in setting the RESET FF. This results in the signal RESET being generated which resets the interface control logic and induces a DATA ACCEPTED signal to initialize the Touch Sensor Controller logic (Figure 4).

EXC 0374 (Select Stream Mode)

The Varian DAS instruction EXC 0374 causes a function code of 3 to be placed on E-Bus lines EB06 through EB08 and results in setting the STREAM FF. This generates the signal STREAM which places the Touch Sensor Controller in the Stream Mode, thus allowing the ADC to digitize the analog data at a 60-hertz rate (Figure 4).

DATA ACCEPTED

When a data transfer instruction is executed, the FRYX-I line goes true indicating that a programmed data transfer instruction and device address are on the E-Bus. DA74 goes true indicating the device address is decoded and E-Bus line EB13 goes true, indicating an input data transfer is about to take place, both partially enabling the DATA ACCEPTED logic. Data transfer occurs from the controller interface X or Y register as selected by a previous EXC command. When the data transfer is completed, the computer places the DRYX-I line true enabling the data accepted logic and generating the DATA ACCEPTED signal. DATA ACCEPTED resets and DATA READY FF in the Touch Sensor Controller, making it available for processing another set of X and Y coordinate values (Figure 4).

USING THE TOUCH SENSOR

Using the Touch Sensor involves programming the Varian computer with the DAS assembly language. The Appendix lists the instruction set for the Touch Sensor.

Programming the Touch Sensor

Initiate the System (EXC 0274):

Before attempting to use the Touch Sensor, the programmed reset instruction (EXC 0274) should be executed. This clears the X and Y Registers and places the Touch Sensor in the Single Point Mode. Once executed, a repetition of this instruction is not necessary in the program sequence, unless the user wants to exit the Stream Mode for the Single Point Mode.

Select Operating Mode (EXC 0274):

The Touch Sensor has two operating modes that can be selected under program control. If the Single Point Mode is desired, no further action is required since the Programmed Reset instruction (EXC 0274) places the Touch Sensor in this mode.

If the Stream Mode is desired, you must execute the Select Stream Mode instruction (EXC 0374). Once this mode is selected only the Programmed Reset instruction will deselect it.

Sense System Ready (SEN 074)

Before transferring the data in the X and Y Registers, the controller status must be interrogated by executing the Sense Controller Ready instruction (SEN 074). When the response to the sense instruction is true, data is in the X and Y Registers ready for transfer.

Select X and Y Registers (EXC 0074 and EXC 0174)

After determining that the sense controller is ready, the X and Y Registers may be selected. This requires a two-step instruction sequence for the X Register and a two-step instruction for the Y Register. To access the X Register, perform the following two-step instruction sequence:

- (1) EXC 0074 (Select X Register).
- (2) INA/INB/IME/CIA/CIB (Output X Register data).

Then access the Y Register by performing the following two-step instruction sequence:

- (1) EXC 0174 (Select Y Register).
- (2) INA/INB/IME/CIA/CIB (Output X Register Data).

This places the X and Y coordinate address of the point touched into a register or memory in the computer for further action by the programmer.

Once the X and Y Register contents are transferred to the computer, the Touch Sensor is ready to process another contact point.

APPENDIX
INSTRUCTION SET

INSTRUCTION SET

SEN	074	Sense Controller Ready
EXC	0074	Select X Address Register
EXC	0174	Select Y Address Register
EXC	0274	Programmed Reset
EXT	0374	Select Stream Mode
INA	074	Input to A Register
INB	074	Input to B Register
IME	074	Input to Memory
CIA	074	Clear and Input to A Register
CIB	074	Clear and Input to B Register