



54

**LEVEL**

12

AFGL-TR-80-0173

**ANALYSIS OF SPACECRAFT CHARGING  
AND GEOPHYSICAL DATA BASES**

Krishin H. Bhavnani  
Maurice F. Tautz  
Edward J. Ziemba

RADEX, Inc.  
192 Log Hill Road  
Carlisle, Massachusetts 01741

Final Report  
1 November 1978 - 30 April 1980

31 July 1980

Approved for public release; distribution unlimited

AIR FORCE GEOPHYSICS LABORATORY  
AIR FORCE SYSTEMS COMMAND  
UNITED STATES AIR FORCE  
HANSCOM AFB, MASSACHUSETTS 01731

DIG  
COLLECTED  
OCT 7 1980

AD A 090020

DDC FILE COPY

80 10 7 045

Qualified requestors may obtain additional copies from the Defense Technical Information Center. All others should apply to the National Technical Information Service.

Unclassified

SECURITY CLASSIFICATION OF THIS PAGE (When Data Entered)

19 REPORT DOCUMENTATION PAGE		READ INSTRUCTIONS BEFORE COMPLETING FORM
1. REPORT NUMBER AFGL-TR-80-0173	2. GOVT ACCESSION NO. AD-A090 020	3. RECIPIENT'S CATALOG NUMBER 9
4. TITLE (and Subtitle) ANALYSIS OF SPACECRAFT CHARGING AND GEOPHYSICAL DATA BASES		5. TYPE OF REPORT / PERIOD COVERED Scientific-Final 1 Nov 1978 - 30 Apr 1980
6. AUTHOR(S) Krishin H. Bhavnani Maurice F. Tautz Edward J. Ziemba		7. PERFORMING ORG. REPORT NUMBER
9. PERFORMING ORGANIZATION NAME AND ADDRESS RADEX, Inc. 192 Log Hill Road Carlisle, MA 01741		8. CONTRACT OR GRANT NUMBER(s) F19628-79-C-0014
11. CONTROLLING OFFICE NAME AND ADDRESS Air Force Geophysics Laboratory Hanscom AFB, Massachusetts, 01731 Contract Monitor: Robert E. McInerney/SUMA		10. PROGRAM ELEMENT, PROJECT, TASK AREA & WORK UNIT NUMBERS 9993
14. MONITORING AGENCY NAME & ADDRESS (if different from Controlling Office) 1975		12. REPORT DATE 31 July 1980
		13. NUMBER OF PAGES 76
		15. SECURITY CLASS. (of this report) Unclassified
		15a. DECLASSIFICATION/DOWNGRADING SCHEDULE
16. DISTRIBUTION STATEMENT (of this Report)  Approved for Public release; distribution unlimited		
17. DISTRIBUTION STATEMENT (of the abstract entered in Block 20, if different from Report)		
18. SUPPLEMENTARY NOTES  Tech, Other		
19. KEY WORDS (Continue on reverse side if necessary and identify by block number) Spacecraft Charging      Rotation      Ion Composition Modeling Electron-Ion Emitters      Simulation      Data Editing Materials Charging      SCATHA      Correlation Analysis NASCAP      Graphics      Distribution Analysis Plasmas      Displays      Partitioning		
20. ABSTRACT (Continue on reverse side if necessary and identify by block number) This report documents investigations and computer programs developed for analysis of spacecraft charging and geophysical data bases.  Spacecraft charging studies have been performed utilizing the NASCAP and associated MATCHG programs. Simple as well as complex SCATHA models have been configured, and results for materials charging, rotation effects, potential monitor,		

DD FORM 1 JAN 73 1473

EDITION OF 1 NOV 65 IS OBSOLETE

Unclassified

SECURITY CLASSIFICATION OF THIS PAGE (When Data Entered)

(2-1) Unclassified

SECURITY CLASSIFICATION OF THIS PAGE(When Data Entered)

and gun events in different environments have been simulated. NASCAP verification and validation to date is summarized.

Ion composition modeling has been initiated using mass spectrometer measurements of  $N_1^+$ ,  $O_1^+$ ,  $N_2^+$ ,  $NO^+$  and  $O_2^+$  ion densities on board the S3-1 satellite. Procedures for partitioning, editing, averaging, and analyzing the geophysical data base are described. Graphical presentation techniques are used extensively, and provide a basis for subsequent modeling.

An interactive graphics program (SUATEK) has been developed to satisfy requirements for flexible data presentation and evaluation by researchers. Data manipulation, editing, as well as selective plotting features are available, and operate on a standardized data base format. On-line Tektronix and Off-line Pen-and-Ink, Microfiche, or Tektronix compatibility is retained as far as possible.

### ACKNOWLEDGEMENTS

The coordination, guidance, and encouragement of our Contract Monitor, Mr. Robert E. McInerney of the Analysis and Simulation Section, on numerous phases of the spacecraft charging, ion composition modeling, graphical display, and related research support projects is greatly appreciated.

Dr. C. R. Philbrick of the Atmosphere Structure Branch and Dr. A. G. Rubin of the Particles and Fields Branch have gratifyingly involved and guided the authors in the conduct and dissemination of exceptional investigations in their respective fields. The collaboration of Dr. N. A. Saflekos of Boston College in many aspects of spacecraft charging is also appreciated.

Thanks are also due to Lt. A. Chesley, F. LeBlanc, and other AFGL investigators who have applied the SUATEK graphics system and contributed to its enhancement.

Approved for Release	<input checked="" type="checkbox"/>
Dissemination	<input type="checkbox"/>
Classification	<input type="checkbox"/>
Administrative	<input type="checkbox"/>
Other	<input type="checkbox"/>
Date: _____	
Signature: _____	
Title: _____	
Organization: _____	

A

## TABLE OF CONTENTS

1.	SPACECRAFT CHARGING	9
1.1	Operational System at AFGL	10
1.2	NASCAP Program	12
1.3	MATCHG Program	15
1.3.1	Materials Charging Studies	16
1.4	Rotational Effects	23
1.5	SCATHA SSPM Experiment Simulations	24
1.6	SCATHA Gun Operation Simulations	28
2.	ICN COMPOSITION DATA ANALYSIS FOR MODELING	32
2.1	Procedures for Analysis of Data	33
2.1.1	Description of Data	33
2.1.2	Data Extraction and Preliminary Editing	35
2.1.3	Distribution Analysis	35
2.1.4	Editing Criterion	37
2.1.5	Correlation Analyses	42
2.1.6	Revised Grouping and Averaging	43
2.1.7	Averaging Summary Profile Plots	43
2.2	Modeling Investigations	45
3.	SUATEK - INTERACTIVE GRAPHICS SYSTEM	51
3.1	Objectives and Implementation	51
3.2	On-line SUATEK User's Guide	55
3.2.1	Program Flow	56
3.2.2	Input/Output	62
3.3	Off-line SUATEK User's Guide	66
3.3.1	Overview	66
3.3.2	Functional Description	69
3.3.3	Program Flow	70
3.3.4	Input Format and Control Cards	71

## LIST OF FIGURES

<u>Sed.</u>	<u>No.</u>		
1	1	Schematic of NASCAP Operating System	11
	2	NASCAP 1-Grid Model of SCATHA Satellite	13
	3	4-Grid SCATHA Model - View from 1,1,1	14
	4	Schematic for MATCHG Charging Algorithm	17
	5	MATCHG Potentials for High Temperatures	20
	6	MATCHG Potentials for Low Temperatures	21
	7	Comparison of the Steady-State Potentials of a Teflon-covered Quasisphere	25
	8	Modulated Voltages: Quasisphere	27
	9	Simulation of Day 89 Gun Cases	29
2	1	Evaluation and Consolidation of Data Base for Ion Composition Modeling	34
	2	Histogram of Sample Counts vs. Kp and SS#	36
	3	Sorted O <sup>+</sup> Data vs. Parameters in a Range	38
	4	Histogram of O <sup>+</sup> Sample Counts vs. Density	39
	5	Data Editing in a Bin with Two Pass Rejection	41
	6	Average, 75 percentile and 25 percentile Profiles for N <sup>+</sup> and O <sup>+</sup> in a Range	44
	7	Latitudinal Parametric Profile Plots for O <sup>+</sup>	47
	8	Computer Fit of O <sup>+</sup> Profile by Chapman Function	49
3	1	Functional Flow of SUATEK	53
	2	Hard Copy of SUATEK Plot on Tektronix Display	67

LIST OF TABLES

Sec. No.

1	1	New and Old (pre 5/79) Material Properties	19
	2	MATCHG Potentials vs. NASCAP Quasisphere	22

## 1. SPACECRAFT CHARGING

Magnetospheric substorms at high altitudes are characterized by hot, tenuous plasmas. This environment can charge a satellite negatively to many kilovolts, with significant differential charging over and across parts of the satellite, and with charging dynamics induced by a fluctuating environment and active control mechanisms. The reliable estimation of these effects on present and future space vehicles has been a concern of the Air Force and NASA for many years, and the subject of considerable R&D activity. (1)

Since the object, the surface-plasma interactions, the plasma environment, and the dynamic mechanisms must be considered in detail, the inclusion of all factors that are significant for spacecraft charging presents quite a formidable problem. Complex three dimensional geometries with cavities and booms must be considered. The internal electrical properties of the spacecraft and the surface-plasma reaction kinetics have to be taken into account. Material properties for secondary emission, backscattering, photoemission and charge transport are needed. The magnetostatic environment may include solar, magnetic field, sub-storm, and space charge effects. Charging dynamics can exist due to varying photoemission over a rotating or eclipsing satellite, changing plasma environments, active control by electron and ion beams, and switching of electrically connected satellite configurations. For a number of years the analytical tool that most comprehensively combines and represents these processes has been the NASCAP program (2,3) developed by Systems, Science and Software. The program represents an attempt to realistically simulate and depict spacecraft charging, and was installed at AFGL in 1978 for the purpose of verification and validation, and as a means for support of investigations into charging phenomena. Since installation many phases of this effort have been supported.

## 1.1 Operational System at AFGL

Figure 1 shows a schematic of the operational system employed at AFGL. The basic source tape, provided by S<sup>3</sup> is in blocked EBCDIC format and a short program is used to read this tape and produce a CDC compatible UPDATE program library file called NASPL. The compiled version of this program library, NASBIN, is much too large to fit on the AFGL computer and it must first be processed by SEGLOAD directives. The segmented version of the program, NASABS, is the actual execution file which is attached by the job run deck.

An auxiliary file NASFILES, which may also be attached by the job, contains parameter values for all the material properties and object definition specifications for the standard SCATHA models. Besides extensive printed output a typical NASCAP run also produces associated microfiche plots and makes accessible a set of run files which may be saved as inputs for subsequent continuation jobs. The run files may be scanned by an auxiliary program, TERMTK, to produce summaries and time histories of the results. The TERMTK generated information can be passed to SUATEK for graphical display of the results (Section 3 describes the SUATEK graphics system). Program changes are inserted in the form of UPDATE modifications to NASPL; the compilation and segmentation runs are subsequently revised. The NASCAP program library and its associated files are dumped onto back-up tapes to protect against possible damage to the source files.

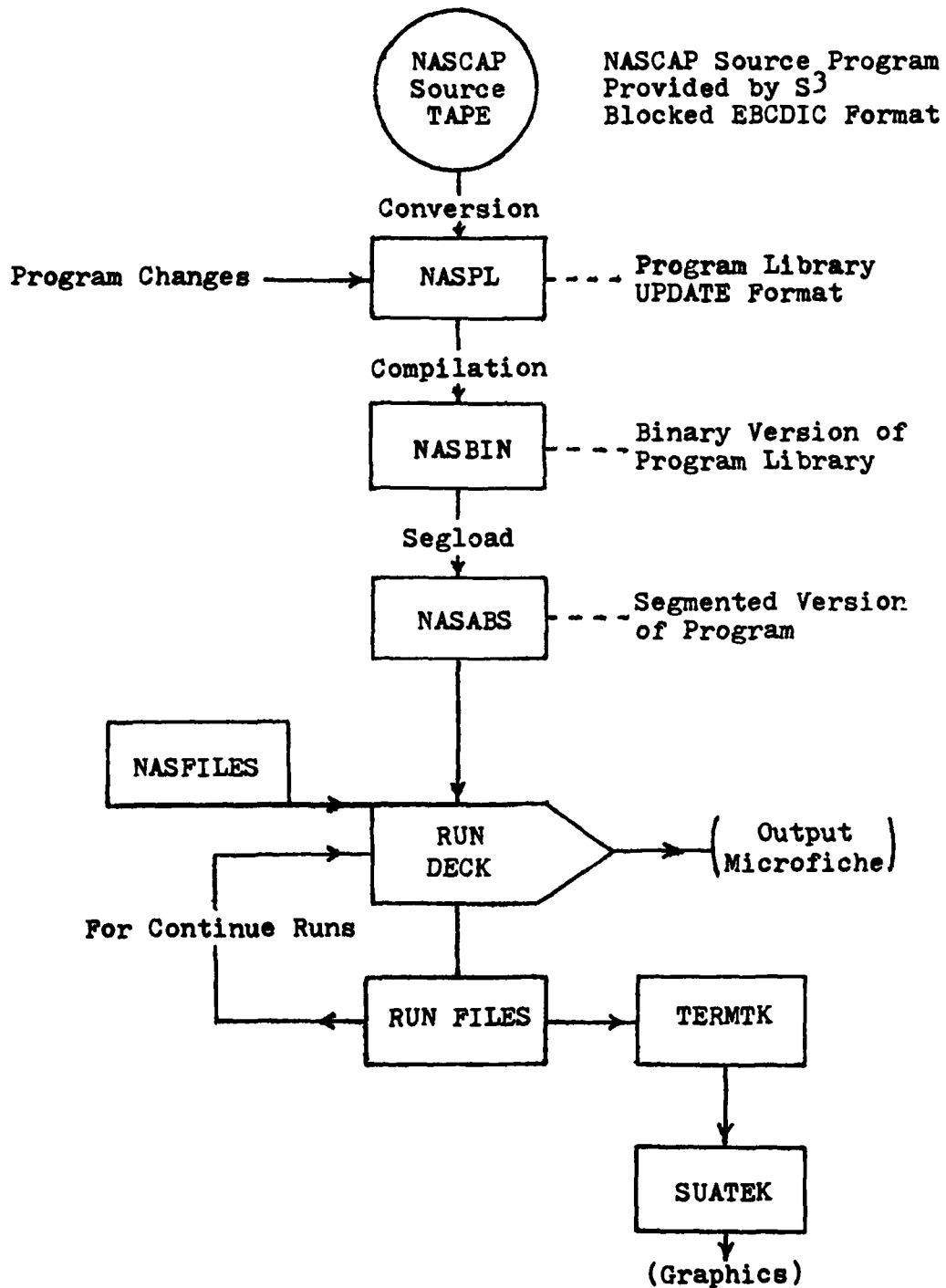

Figure 1. Schematic of NASCAP Operating System

## 1.2 NASCAP Program

NASCAP simulates space craft charging using a quasi-static Vlasov equation approximation to solve for the surface charging fluxes, given potential distributions and ambient magnetic field. Following the calculation of dielectric charge transport and surface charge distributions, Laplace's equation is solved, using a finite element nested-mesh technique, to obtain the potentials in the space surrounding the vehicle. The iterative cycle then returns to the flux charging equations.

The program is comprised of over 450 subroutines and requires about 240 K<sub>B</sub> (after segmentation) to run on the CDC 6600.

The spacecraft object is defined by combining basic building blocks (cubes, wedges, tetrahedrons) to form a representative volume in the mesh space. Larger composite blocks and overlapping occupation of mesh spaces simplify the configuration of vehicles with complex structure. Special elongated cylindrical elements are available to simulate satellite booms. Figures 2 and 3 show the simplest SCATHA model (1 grid) and the most complex model (4 grid).

Each exposed surface of the object must be associated with a material which is characterized by 15 parameters (dielectric constant, conductivity and secondary emission properties, etc.). Up to 7 different underlying conductors may be specified and these can be interconnected by means of capacitors. Bias voltages between conductors may be set or selected conductor voltage levels may be held fixed. Particle emitters can be

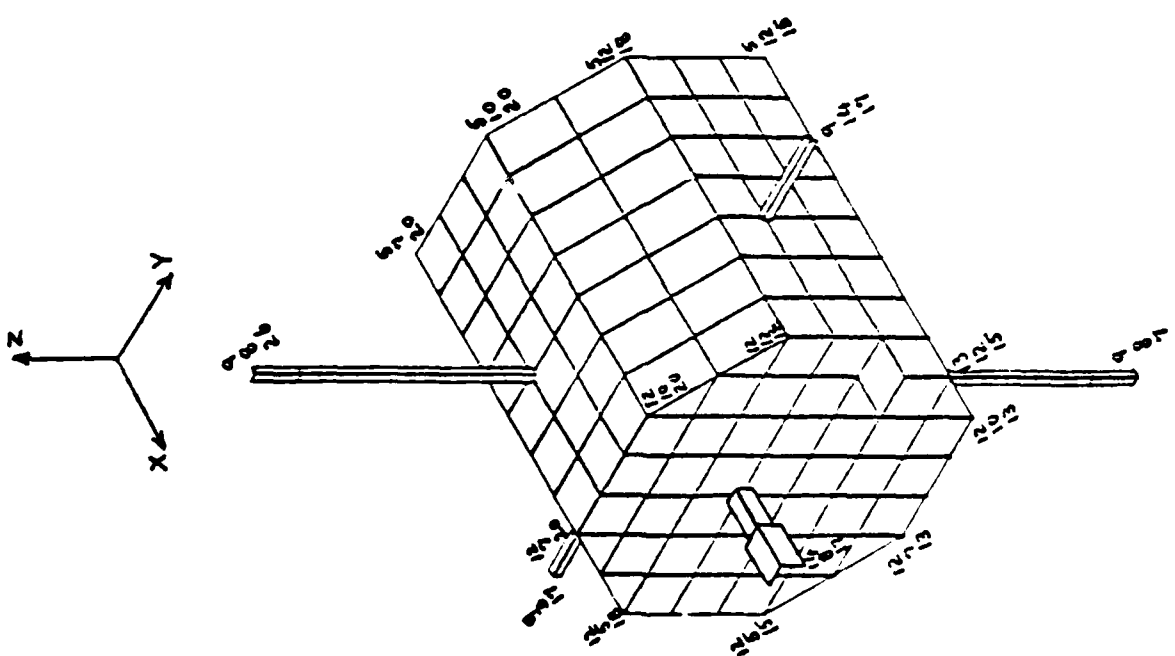
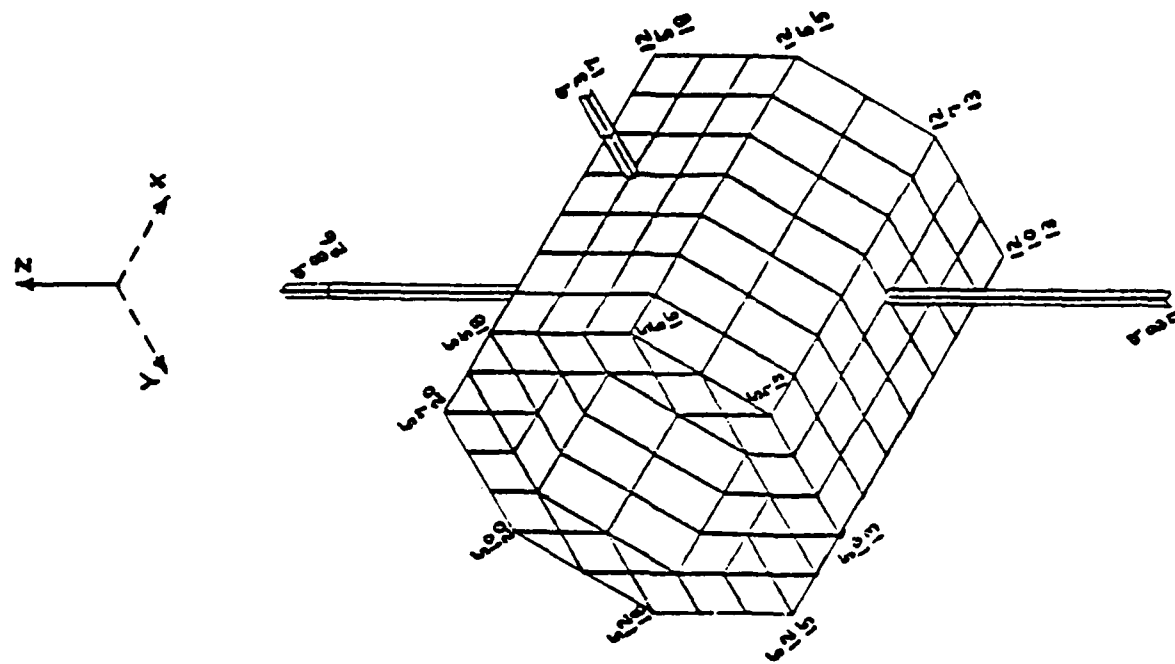

Figure 2. NASCAP 1-Grid Representation of SCATHA Satellite

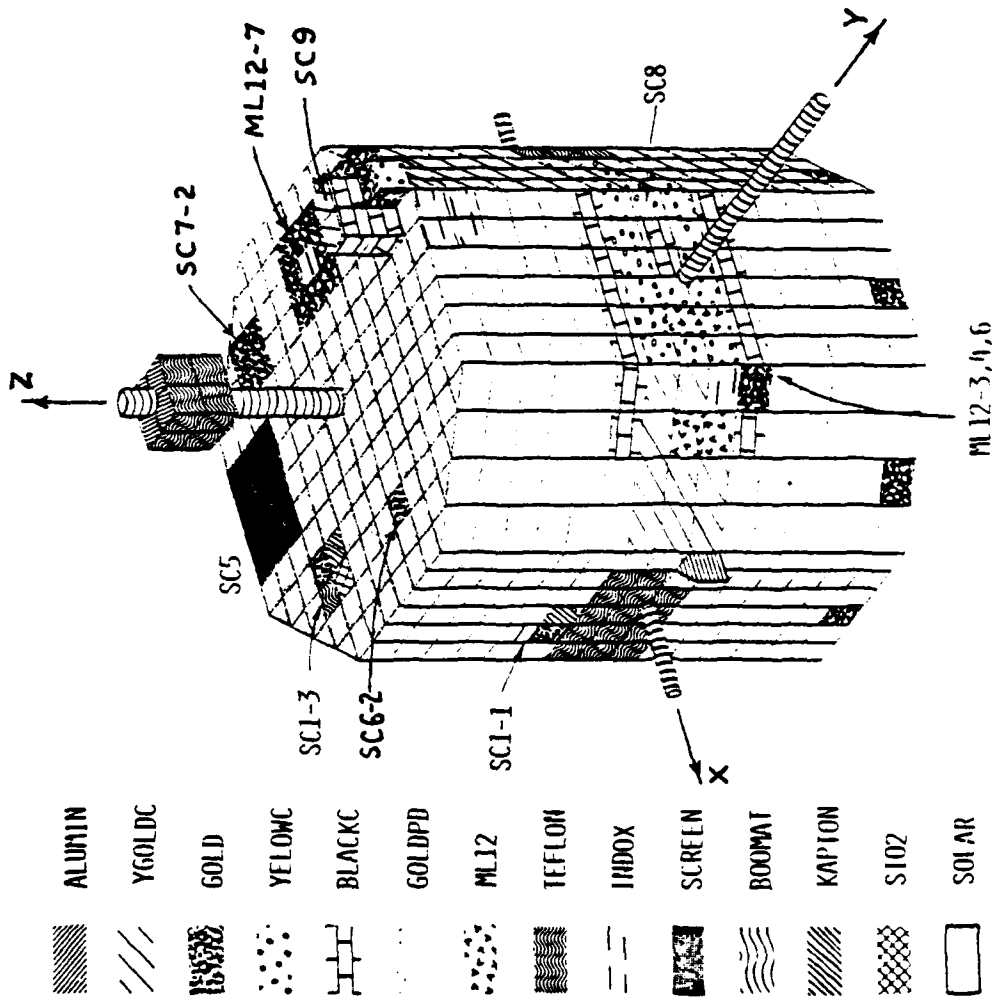

Figure 3. 4-Grid SCATHA Model - View from 1,1,1  
 (Provided by Systems Science & Software)

attached to the satellite surfaces; the geometry of the gun, the type of emitted particles, the average energy and energy spread, and the average current can be adjusted. Particle detectors also can be placed on designated surface cells - the geometrical and kinematical acceptance range can be varied.

The plasma environment can be described by single or double Maxwellian distributions - the density and temperature for each species must be given. A test tank representation is also available. The sun intensity and direction can be specified and the program will correctly take into account shadowing effects of the satellite body. For the simulation of rotating spacecraft there are two principle modes of operation:

SPIN - uses the average sun illumination corresponding to very rapid angular velocity

ROTATE - generates the exact sun illumination for each time step of the rotation

In the program, the spacecraft body remains fixed (attached to the mesh frame) and the sun rotates around it. The environment may include an ambient magnetic field, which is also subject to this kinematical rotation.

### 1.3 MATCHG Program

The MATCHG program charges a surface by means of the same materials formulations that are used in NASCAP. It enables one to obtain estimates of the equilibrium potentials for a surface immersed in a specified plasma environment for those cases where one can neglect surface conductivity, photo-emission, emitter currents and multi-dimensional effects. The program algorithm

consists of finding the net charging current (plasma current plus materials interactions) and then calculating the corresponding voltage change, assuming a simple lumped circuit model for the surface. The model consists of a capacitor and a by-pass resistor for the leakage current as shown in Figure 4. The backing plate voltage on the capacitor is held fixed and therefore the time dynamics will not be correct for cases where the underlying conductor voltage is changing. For example, in eclipse charging the underlying conductor and the surface potential tend to go up together and the actual time constant is much smaller than that given by MATCHG. However, the equilibrium potentials in eclipse can be estimated from MATCHG if one sets the bulk conductivity to zero ( this eliminates the leakage current and, in effect, is the same as putting the potential difference between the surface and underlying conductor to zero). To obtain good estimates of the equilibrium potentials in the general case, one has to preset the backing plate value to the voltage on the underlying conductor.

### 1.3.1 Materials Charging Studies

The MATCHG code has been run extensively and modified several times. The results of the calculations have been collected in AFGL technical memorandum.<sup>(5)</sup> The topics considered are outlined below

- a) comprehensive comparison of potentials obtained with the old materials properties ( pre 5/79) and the revised properties (provided by S3). Table 1 gives the complete set of old and new parameter values.

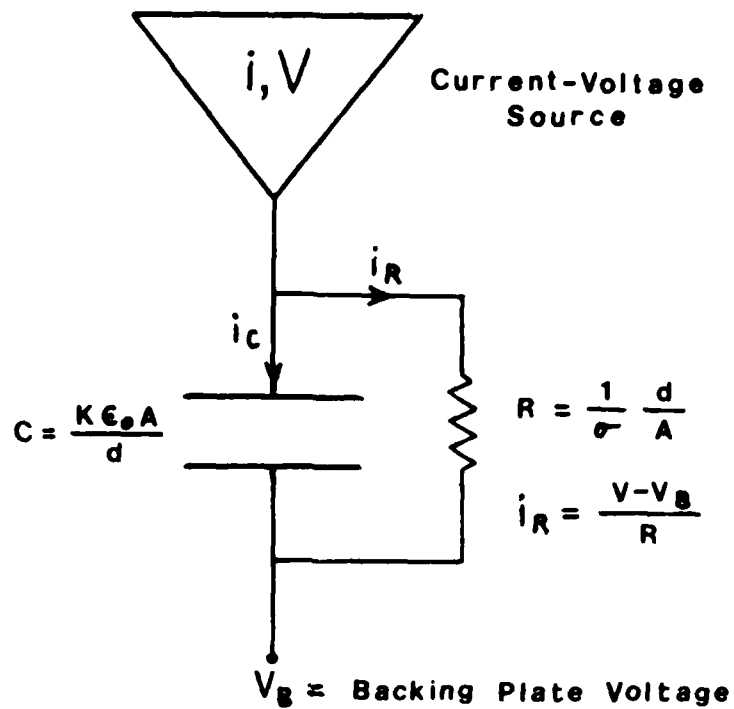

CHARGING EQUATION:

$$\frac{dV}{dt} = \frac{i_c}{C} = \frac{i - i_R}{C}$$

- d = Surface Thickness
- A = Surface Area
- K = Dielectric Constant
- $\sigma$  = Bulk Conductivity

Figure 4. Schematic for MATCHG Charging Algorithm

- b) sensitivity studies for the parameters which significantly affect the potentials.
- c) comparison of the potentials obtained for a single Maxwellian distribution and for the corresponding double Maxwellian.
- d) for many different materials, a systematic calculation of charging potentials as a function of plasma temperature was made. The temperature range extended from very low values ( $\sim 1\text{ev}$ ), where some interesting non-linear effects are observed, up to substorm temperatures. Fig 5 shows the MATCHG potentials for the high temperature range, and Fig 6 for the low temperature region.
- e) comparison of MATCHG equilibrium potentials with the corresponding NASCAP results for a quasisphere, in a fixed sun environment. The shade-side voltages were compared to the MATCHG predictions, with the backing plate fixed at the NASCAP steady state ground potential. As shown in Table 2, there was good agreement for all the materials tested, except for BOOMAT. The reason for the latter discrepancy is that BOOMAT has a large surface conductivity current which is not accounted for in MATCHG.
- f) calculation of bulk conductivity effects on charging for various materials and as a function of backing plate voltage.
- g) effect of plasma density and of electron to ion temperature ratio on the charging potentials.
- h) testing of an alternate formulation of the secondary emission based on Sternglass<sup>(6)</sup> and Wall<sup>(1)</sup> equations.
- i) presentation of a graphical procedure for predicting the voltage response with bulk conductivity from the no-conductivity characteristics.
- j) solution of the circuit equations representing linearized MATCHG calculations.

Table 1. New and Old (pre 5/79) Material Properties

PROPERTY	M A T E R I A L														
	GOLD	SULAR	WHITEN	SCREEN	YELLOWC	ODIDPD	BLACKC	KAPTON	SI02	TEFLON	INDOE	Y00ZC	ATJMEHP	BOONAT	MIL2
1 Dielectric Constant	1.0	4.0	3.5	1.0	3.5	1.0	3.5	3.5	4.0	2.0	1.0	1.0	1.0	2.0	1.0
2 Thickness meters	1.E-3	1.79E-4	5.E-5	1.E-3	1.E-3	1.E-3	1.E-3	1.27E-4 (1.25E-4)	2.75E-4	1.27E-4 (1.25E-4)	1.E-3	1.E-3	1.E-3	5.E-3	1.E-3
3 Conductivity mho/cm	∞	1.E-17 (1.E-16)	5.9E-14	∞	∞	∞	∞	1.E-14	2.75E-12	1.E-14	∞	∞	∞	1.E-13	∞
4 Effective Atomic No.	79.	10.	5.	1.	5.	70.1	5.	5.	10.	7.	24.4	42.	13.	63.4	6.
5 Yield for Electrons $\delta_{max}$	.89	4.1	2.1	0.	2.1	1.03	2.1	2.1	2.4	3.0.	1.4	1.49	0.97	0.88 (1.66)	1.0
6 $E_{max}$ KeV	.8	.41	.15	1.	.15	.72	.15	.15	.4	.3	.8	.48	.3	.8 (.59)	.3
7 Range $\Delta^0$	83.	—	—	10.	—	83.	—	—	—	300 (—)	—	—	260.	83.	—
8 Exponent <sub>1</sub>	1.63	—	—	1.5	—	1.63	—	—	—	1.59 (—)	—	—	1.3	1.63	—
9 Range <sub>2</sub> $\Delta^0$	34.6	2.3 <sup>a</sup>	1.05 <sup>a</sup>	0.	1.05 <sup>a</sup>	34.6	1.05 <sup>a</sup>	1.42 <sup>a</sup>	1.02 <sup>a</sup>	100. (2.)	7.18 <sup>a</sup>	10.2 <sup>a</sup>	240.	34.6	2. <sup>a</sup>
10 Exponent <sub>2</sub>	.7	20.8 <sup>b</sup>	9.8 <sup>b</sup>	1.	9.8 <sup>b</sup>	.7	9.8 <sup>b</sup>	9.8 <sup>b</sup>	20.8 <sup>b</sup>	2. (16.7)	55.5 <sup>b</sup>	42.0 <sup>b</sup>	1.73	.7	12.0 <sup>b</sup>
11 Yield for 1 KeV Proton <sup>a</sup>	.413 (1.40)	.244 (1.36)	.455 (1.40)	0.	.455 (1.40)	.413 (1.40)	.455 (1.40)	.455 (1.40)	.455 (1.40)	.455 (1.40)	.244 (1.36)	.413 (1.40)	.244 (1.36)	.413 (1.40)	.455 (1.40)
12 Energy for Max. Yield KeV	135. (50.)	230. (40.)	140. (70.)	1.	140. (70.)	135. (50.)	140. (70.)	140. (70.)	140. (70.)	140. (70.)	230. (40.)	135. (60.)	230. (40.)	135. (50.)	140. (70.)
13 Photoemission $\mu$ Max	29.	20.	20.	0.	20.	29.	20.	20.	20.	20.	32.	24.	40.	27.2	21.
14 Surface Reactivity obs <sup>c</sup>	0.	1.E+19	1.E+13	0.	0.	0.	0.	1.E+16	1.E+11	1.E+16	0.	0.	0.	1.E+11	0.

(a) density(gm/cm<sup>3</sup>) (b) mean atomic wt. for Feldman's formula

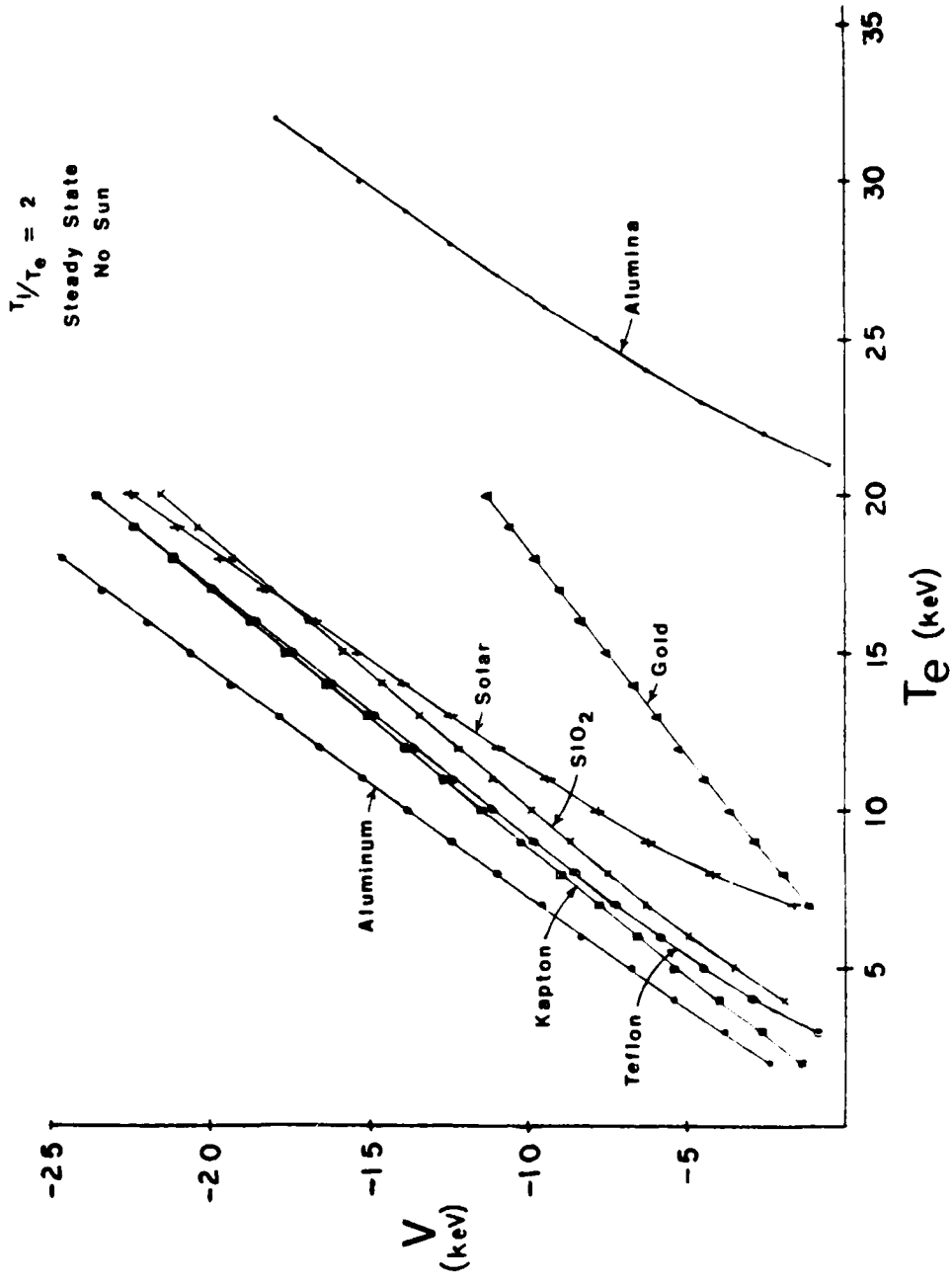

Figure 5. MATCHG Potentials for High Temperatures  
(post 5/79 properties, no bulk conductivity)

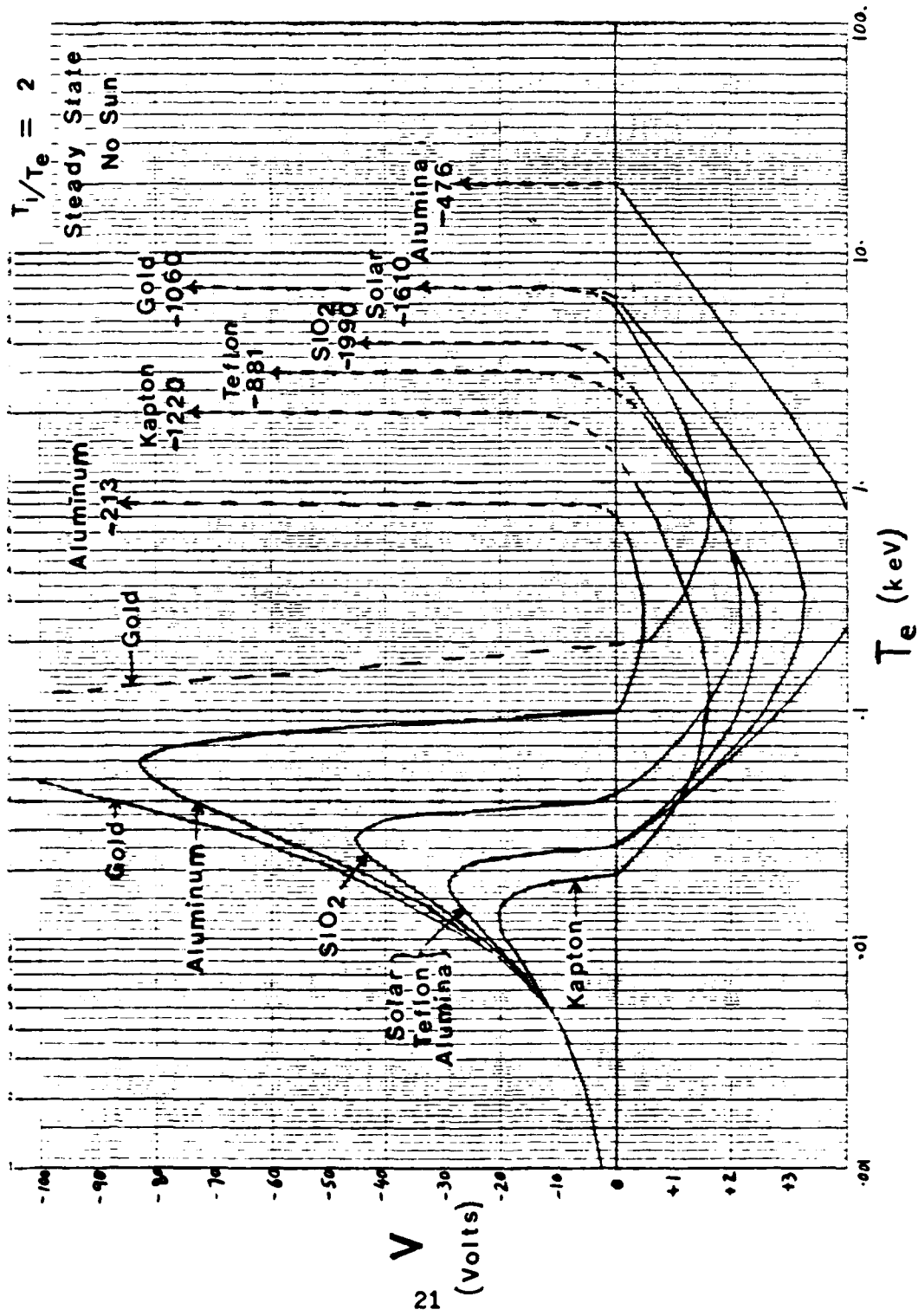

Figure 6. MATCHG Potentials — Low Temperature Range (post 5/79 material properties)

Table 2. MATCHG Potentials vs. NASCAP Quasisphere

MATERIAL	NASCAP QUASISPHERE		MATCHG	
	SHADE POTENTIAL	CONDUCTOR POTENTIAL	BACKING PLATE	FINAL POTENTIAL
TEFLON	-8894	-7125	-7100	-8800
KAPTON	-9210	-7378	-7380	-9210
SOLAR	-7820	-6264	-6260	-7820
SI02	-358	-279	-280	-360
WHITEN	-2997	-2395	-2390	-2990
BOOMAT	-1710	-1023	-1020	-3950

PLASMA is  $T_e = 10$ ,  $T_i = 20$  KeV,  $N_e = N_i = 10^6 \text{ M}^{-3}$   
 SUN is in direction (1,1,1)

#### 1.4 Rotational Effects

The complexities of the physical processes determining the state of a three dimensional object rotating in a magnetospheric environment result in behavior, corroborated by observations, that are not intuitively obvious. These studies are served by investigating charging of simple objects such as spheres and cylinders in the sun, with and without rotation. A technical report that was completed<sup>(?)</sup> gives a survey of the effects of rotation on substorm charging for a quasisphere in a solar environment. It is shown that there is a dramatic difference in potential distribution between a three axis stabilized and a rapidly spinning satellite. For the non-rotating case, the poles and shaded side of the quasisphere reach voltages approximately twice those in the sun direction. The rapid spin case assumes average solar flux illumination at all angles. This results in a decrease to  $\sim 2/3$  of the steady state voltages at the poles, compared to the stationary case. Also, the potentials become uniform around the quasisphere equator and are reduced to  $\sim 1/5$  with respect to the fixed sun direction values. Figures 7A and 7B show the steady-state potentials for the 3-axis stabilized quasisphere and for the rapidly spinning case.

The case of slow spin (at 1RPM) was also studied, using the ROTATE option of NASCAP which allows for simulation of the rotational time dynamics, by calculating at discrete angular steps. The steady state results for the slow spin was shown to constitute a distinct intermediate case, asymptotic to the rapid spin state, but with appreciable voltage modulation around the spin equator.

The potential contours still exhibit the saddle point behavior, resembling a combination of monopole and dipole components, unlike the rapid spin case where the dipole contribution averages out. A few steps after the continuation from the rapid spin state the potential contours lag the rotation and become non-symmetrical. Figure 7 illustrates schematically the steady state potentials for the three cases that were considered.

#### 1.5 SCATHA SSPM Experiment Simulations

One surface potential monitor experiment simulation study was completed.<sup>(8)</sup> Steady state and spin modulated voltages were obtained for quasisphere, 1-grid, 2-grid and 4-grid SCATHA models immersed in the estimated plasma environment (based on SC2) for the day 114 charging event.

In these preliminary simulations, numerical agreement between calculated voltages and measurements was poor and an integral part of the runs was the evaluation and debugging of the NASCAP code. Qualitatively, the program calculated correctly in the sense that:

- The vehicle potential remained at approximately zero and the voltages for the SC1-3 samples, which are situated on the shaded top-side of SCATHA, reached steady values.

# QUASISPHERE (TEFLON)

Plasma:  $T_e=10$  keV,  $T_i=20$  keV,  $N=10^6/M^3$

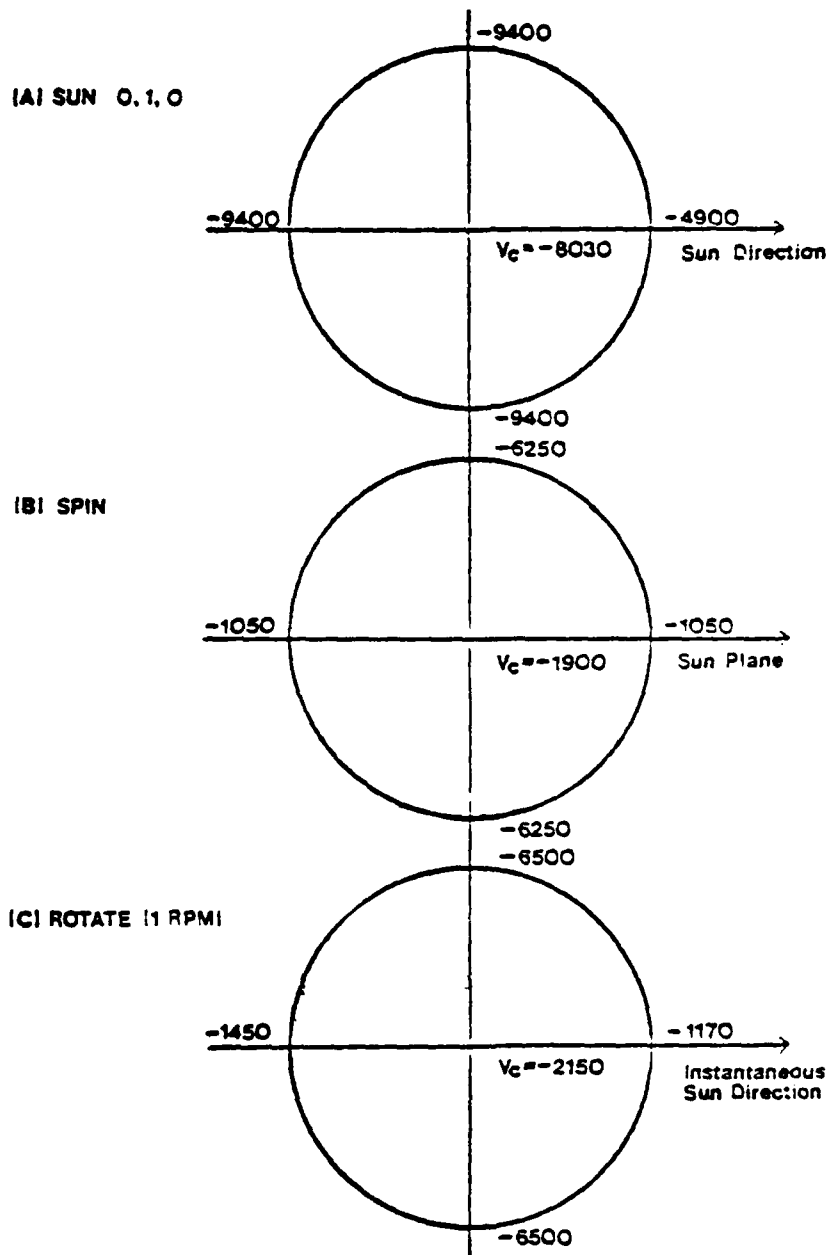

Figure 7. Comparison of the Steady-State Potentials of a Teflon-covered Quasisphere for (a) No Spin, (b) Rapid Spin, and (c) 1 rpm

- The voltages calculated for the SC1-1 and SC1-2 samples, which are  $180^\circ$  apart and rotate into and out of the sun, showed the proper spin modulation. An example of the periodic potentials obtained for a NASCAP quasisphere is shown in Figure 8.

Discrepancies occurred between the magnitudes of the calculated and measured potentials. The amplitudes of the modulated voltages were substantially lower than those observed and the program predicted that the potentials for the Kapton and teflon samples should be about the same, whereas the measurements gave unexpectedly high values for teflon.

Other results from the report are:

- consistency between 2 grid, 4 grid and quasisphere results
- effect of varying the density for quasisphere in eclipse case
- effect of increasing the thickness of the Kapton layer by a factor of 10 on the spin modulation voltages
- calculation of increase in modulation voltages in hotter plasma environments
- comparison of results for a mixed quasisphere (goldpd body with Kapton patches) with those for the pure Kapton case.

$T_e = 10, T_i = 20 \text{ keV}$

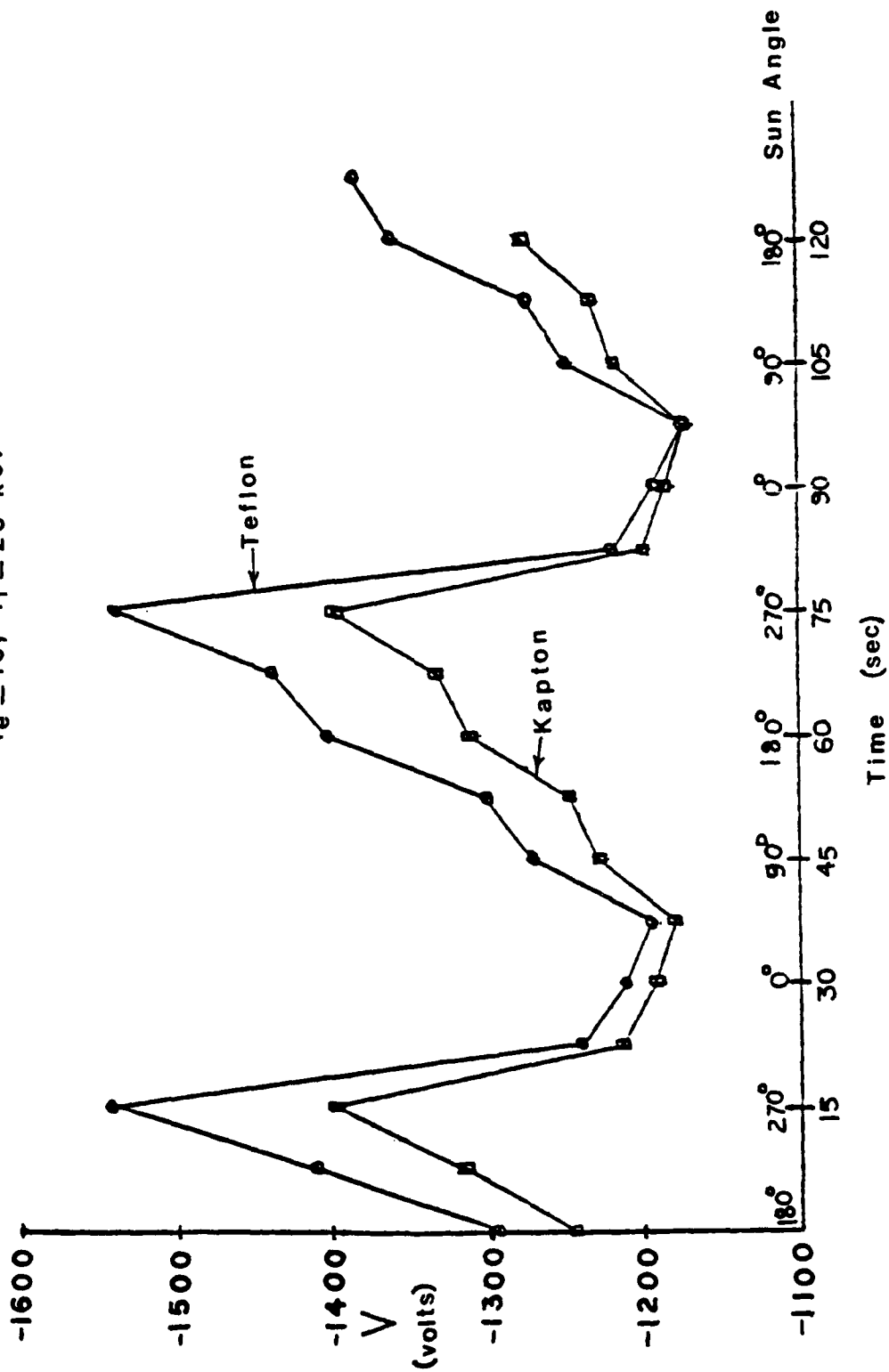

Figure 8. Modulated Voltages; Quasisphere (Teflon and Kapton)

## 1.6 SCATHA Gun Operation Simulations

A large number of NASCAP runs have been carried out to simulate the day 89 gun operations on SCATHA. (9) The program model consisted of a spacecraft object spinning rapidly in the in situ plasma environment; the electron gun is turned on and a transition to a new equilibrium state occurs. The ambient magnetic field was initially neglected and, to save computing time, the spatial object was represented by a 2 grid SCATHA model or a quasisphere with the body capacitance scaled up to equal the 2-grid value.

Trial runs were done to set the time-step in the correct dynamic range and to properly adjust the parameters that control the gun trajectory tracking. The parameters which were varied were

LIMGRD number of grids that particles are tracked in  
(6 - 12)  
NSTEPS total number of tracking steps allowed  
CYMULT time limit cut-off (1 - 900)

The most important variable was CYMULT. Only after increasing this parameter did the return currents look reasonable.

Figure 9 gives an overview of the NASCAP results. The cases fall into two distinct classes, low emitter current ( $10 \mu\text{A}$ ) and high current ( $\geq 100 \mu\text{A}$ ). In the former case, the code predicts that the ambient plasma can supply enough current to balance the gun output. The vehicle potential goes positive, but stays well below the gun energy, in qualitative agreement with observations. For the high current case, NASCAP finds that the vehicle charges up to values slightly higher than the gun energy. The discrepancy is most likely due to

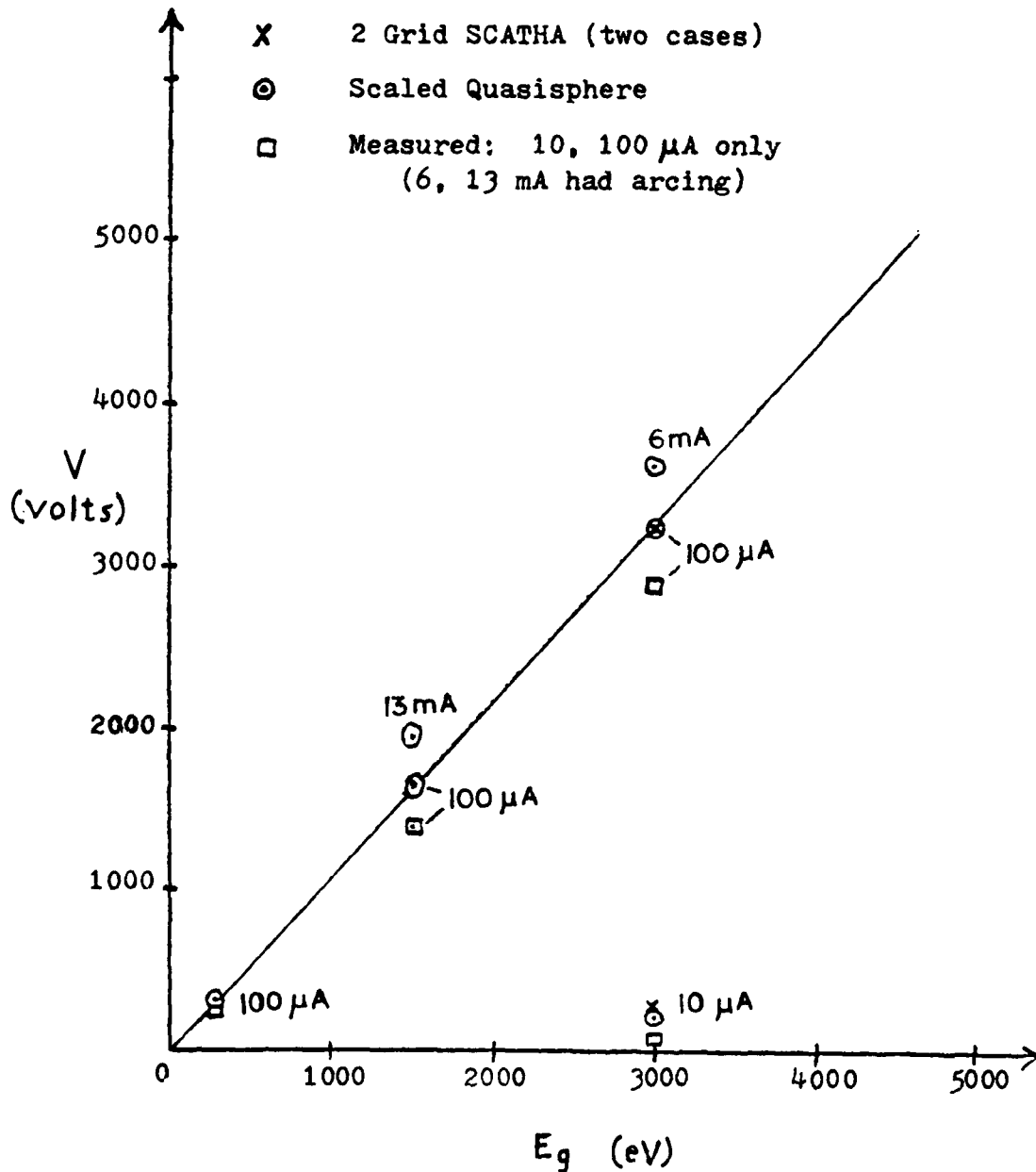

Figure 9. Simulation of Day 89 Gun Cases

space charge effects at the gun outlet, which are not taken into account in the present version of NASCAP. With the  $100 \mu\text{A}$  gun current the program finds a 80% return current to the satellite. This amount is consistent with  $\sim 20 \mu\text{A}$  net current to the satellite from the environment, a number which has been checked for consistency, by runs with the emitter turned off. For the very high current cases (6, 13mA) a proper current balance is not achieved, due to the finite trajectory method employed in the program.

### REFERENCES

1. "Proceedings of the Spacecraft Charging Technology Conference," AFGL -TR-77-0051, February 1977.
2. Katz, I. et al, "A Three Dimensional Dynamic Study of Electrostatic Charging in Materials", Systems, Science and Software, NASA CR-135256, August 1977
3. Katz, I. et. al, "Extension, Validation and Application of the NASCAP Code", Systems, Science and Software, NASA CR-159595, January 1979
4. Cassidy III, J.J. "NASCAP User's Manual-1978", Systems, Science and Software, NASA CR-159417, August 1978
5. Tautz, M.F., Bhavnani, K.H., McInerney, R.E. and Rubin, A.G., "Prediction of Materials Charging in Magnetospheric Plasmas", AFGL-TM-31, January 1980
6. Solid State Physics (Advances in Research and Applications), Vol.6, Academic Press, 1958; "Secondary Electron Emission by A.J.Dekker, p. 279
7. Rubin, A.G., Bhavnani, K.H., and Tautz, M.F., "Charging of Spinning Spacecraft", AFGL-TR-79-0261 October 1979
8. Tautz, M.F. et al, "SSPM Experiment Simulation Study for the April 24, 1979 Charging Event", AFGL TM-23, August 1979
9. Tautz, M.F., Rubin, A.G., and Saflekos, N.A., "Preliminary Simulation of Electron Emitter Events of March 29, 1979", AFGL-TM-33, March 1980

## 2. ION COMPOSITION DATA ANALYSIS FOR MODELING

A consolidated data base of mass spectrometer measurements of  $N^+$ ,  $O^+$ ,  $N_2^+$ ,  $NO^+$  and  $O_2^+$  ion densities on board the S3-1 satellite has been processed for Ion Composition studies of the region from 150 to 500 Km. Procedures for partitioning, editing and averaging by selected ranges of the influencing parameters have been investigated and applied. Ion density correlation analyses vs. known and candidate casual factors have been performed. Average and distribution profiles are graphically presented. Modeling investigations have been initiated through parametric profile plots, comparisons with a preliminary Rower model, and analytical fitting of profiles. This project represents the first step toward developing an ionospheric model based on S3-1 and S3-2 satellite measurements, and the effort has been described earlier in detail.<sup>(1)</sup> A summary of the procedures employed and the results to date are presented here.

The problem was divided into the following tasks:

- 1) Data editing
- 2) Distribution analysis
- 3) Correlation analysis
- 4) Averaging and partitioning by intervals
- 5) Model development
- 6) Comparison of model developed with existing ionospheric models.

For the S3-1 data available, the first four tasks have been completed. Resultant average density curves have been compared, on a limited scale, with existing ionospheric models. The original data has been processed

per specie, for selected ranges of altitude, latitude, solar zenith angle, Kp and season, and the resultant statistics are available for further analyses on files and in tabular and graphical form. These statistics include average and distribution calculations for the edited data in each range or bin. Current and future modeling effort is based upon these statistics. Extensive graphical analyses have been made, using the SUATEK plotting system described in Section 3.

Figure 1 presents a functional diagram of the procedures that have been applied, starting from the geophysical ion density data base, and after editing, evaluation and partitioning, providing a consolidated data base for modeling purposes.

## 2.1 PROCEDURES FOR ANALYSIS OF DATA

### 2.1.1 Description of Data

The data base consisted of data obtained from a mass spectrometer (MSIV) on board the S3-1 satellite.<sup>(2)</sup>

The data provided included data for approximately 1100 orbits from orbit 55, 11/4/74 through 1793, 3/25/75. Samples were taken for about 20 minutes around perigee, giving upto 100 samples per orbit at altitudes from 145 Km, to 500+ Km. Additionally, an Indices file was provided for the lifetime of the S3-1 satellite. This file contains geophysical indices necessary for the interpretation of the measurements including Kp, F<sub>10.7cm</sub> solar flux, Ap, DST index, sunspot number, solar flare indices and solar declination.

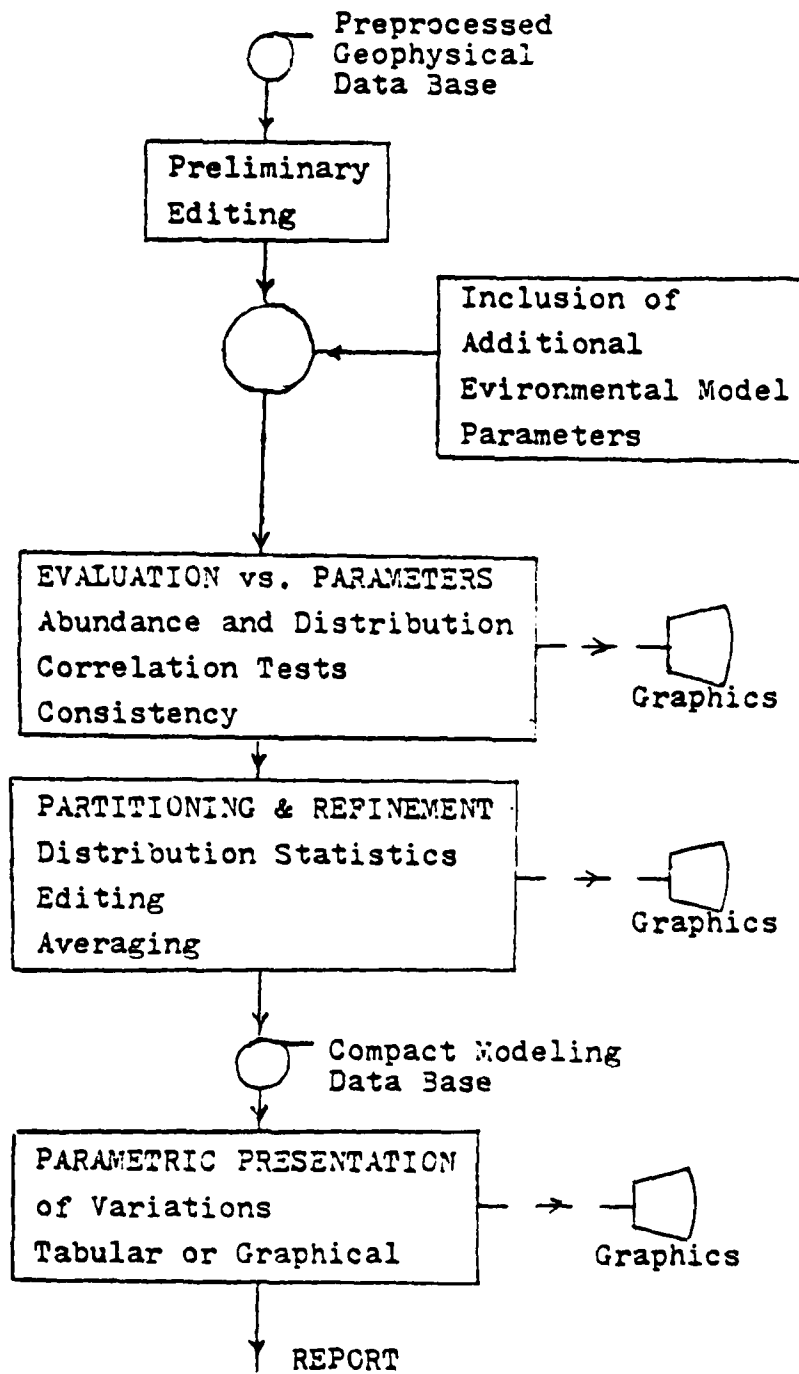

Figure 1. Evaluation and Consolidation of Data Base for Ion Composition Modeling

### 2.1.2 Data Extraction and Preliminary Editing

For the analysis undertaken, a subset of the data available was extracted and saved for future analysis. That is, the date, orbit number, position, time and density portions of the MSIV data, along with the indices files, were merged. Additionally the solar zenith angle for each data frame was calculated and saved. Portions of the data provided contained discontinuities. Software was written to edit this erroneous data where possible. Further, within the processing program, checks were incorporated to eliminate data such as readings below 10, which were reported inaccurately by the instruments.

### 2.1.3 Distribution Analysis

The purpose of this analysis was to determine the proper categorizations in which to group the S3-1 ion data. Related literature was reviewed to select proper intervals. Histograms of possible controlling parameters were generated to aid in the categorization and bin selection. Figure 2 shows the Kp and sunspot number distributions for the total data base, prior to subdividing into categories. While the effort focused on choosing bins which were proper, it was anticipated at the outset that future revisions would be required. The software developed to calculate the distribution was done in a flexible manner so that expansions, combinations or the inclusion of additional parameter range designations could easily be implemented.

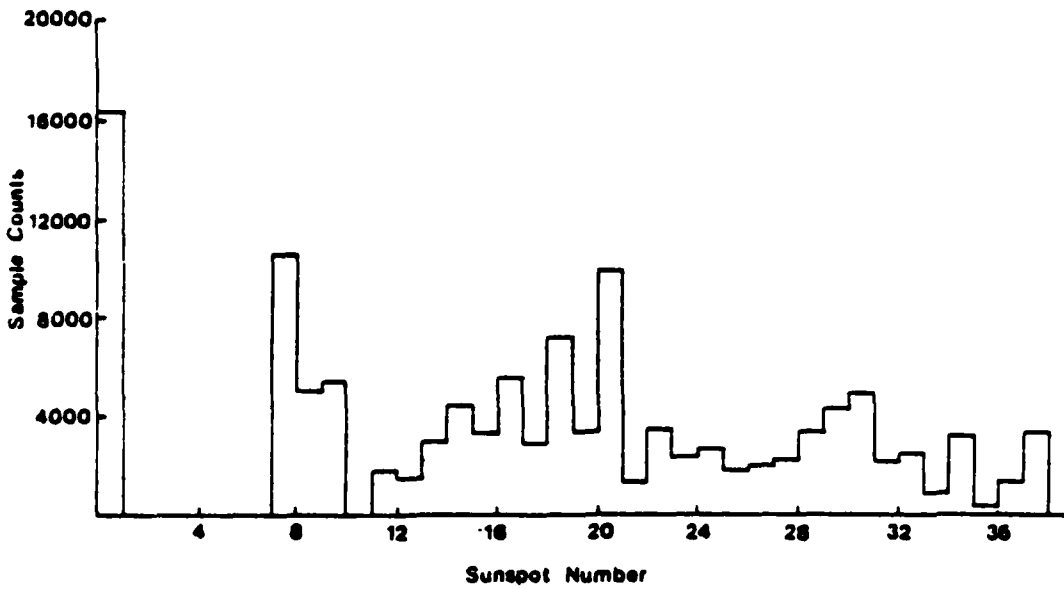
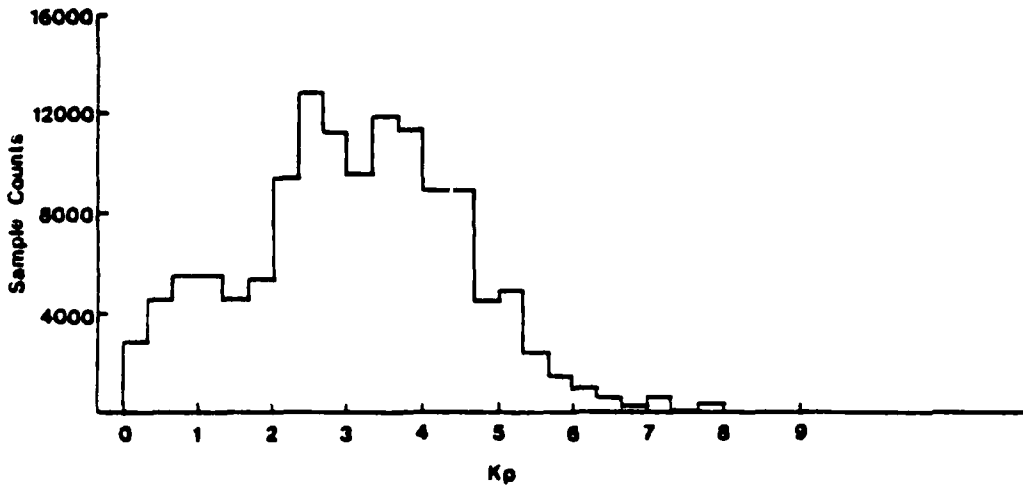

Figure 2. Histogram of Sample Counts vs.  $K_p$  value and Sunspot Number. The large number of measurements at Sunspot Number 0 is due no observations during cloud cover, etc.



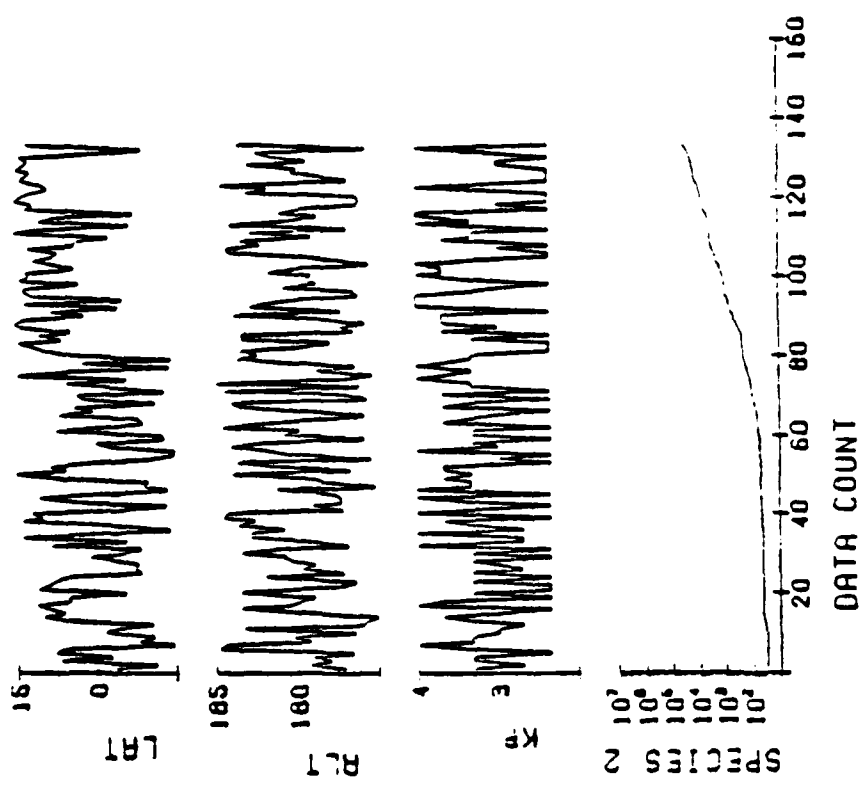
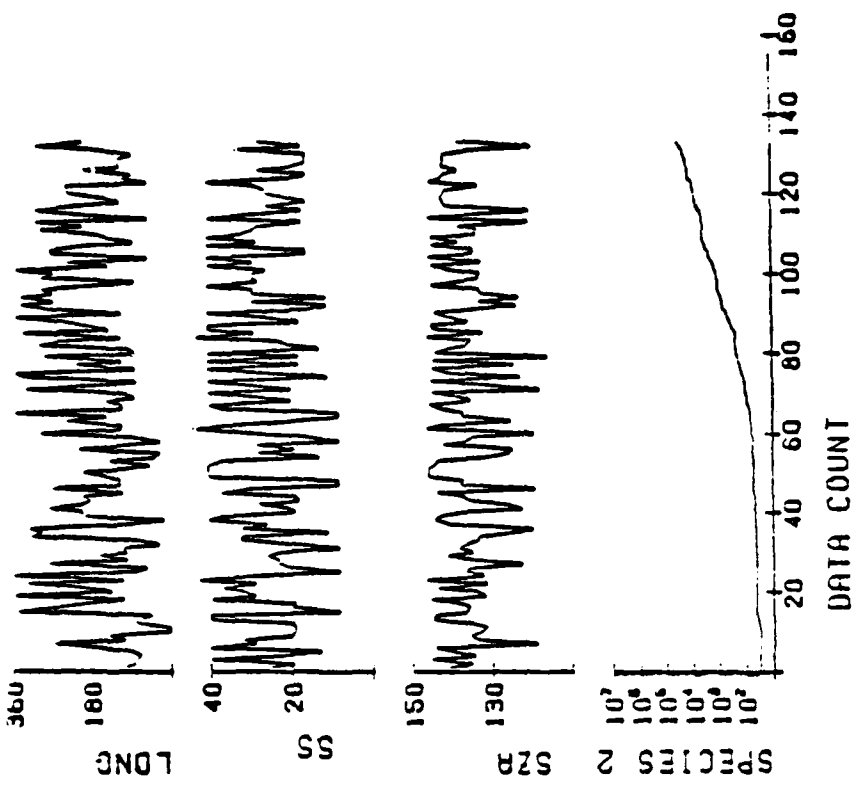

Figure 3. Plot of Sorted  $\sigma^+$  Data at 180 Km vs. Controlling Parameters in a Limited Range

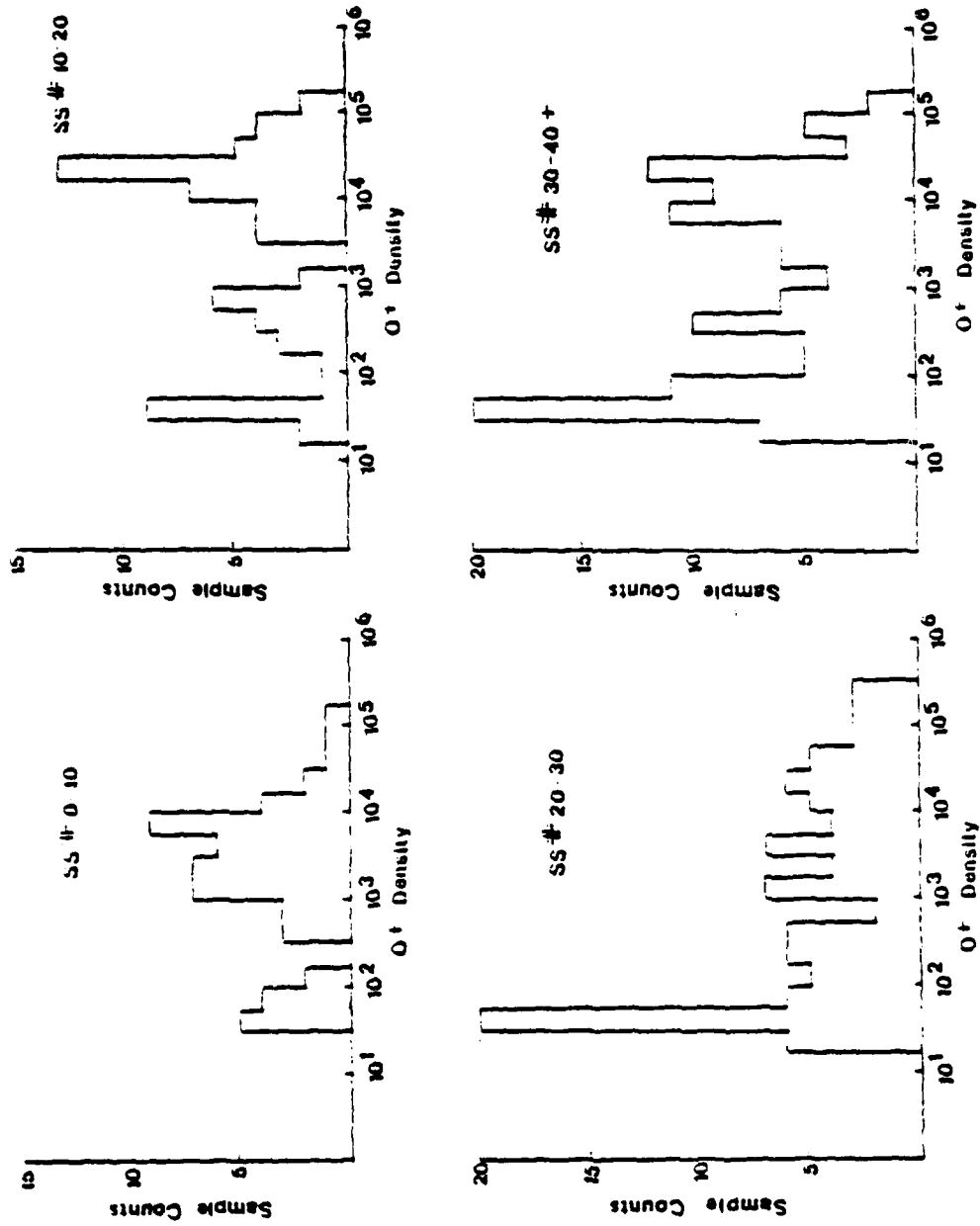

Figure 4. Histogram of O<sup>+</sup> Sample Counts vs. Density for Nighttime, 15-45 Latitude, 2-4 Kp, 185-195 km Altitude, and Four Sunspot Number Ranges

The entire S3-1 data set was processed. Processing included the above mentioned categorizations plus a method for eliminating widely varying data within any subgroup. The final statistics, means and standard deviations were also saved. The analysis suggested that the data should be converted to a form possessing a normal distribution, such as log values, prior to applying the rejection criteria, but that the subsequent averaging should be done on the actual values. Hence the following algorithm was included in the software:

- 1) Calculate the means and standard deviations of the logs of the density values.
- 2) Eliminate any values less than the mean minus twice the standard deviation or greater than the mean plus twice the standard deviation.
- 3) Recalculate the log means and log standard deviations with the subset of data.
- 4) Eliminate a second time with the two standard deviation criterion.
- 5) Calculate the actual means and standard deviations, not the logarithmic values, and save these statistics.

An example of the rejection criterion for eliminating data within a bin is given in Figure 5. The dashed lines indicate the wider acceptance criterion used on the first pass, and the solid lines show the acceptance band for retaining the final sample set. These samples are subsequently averaged to give the arithmetic mean for least squares fitting and other modeling investigations. Notice that this mean exceeds the log mean, the difference being directly dependent upon the standard deviation.

$U^+$  SZA > 110, 60-70 IAT, 2-4 Kp, 175-185 Km altitude

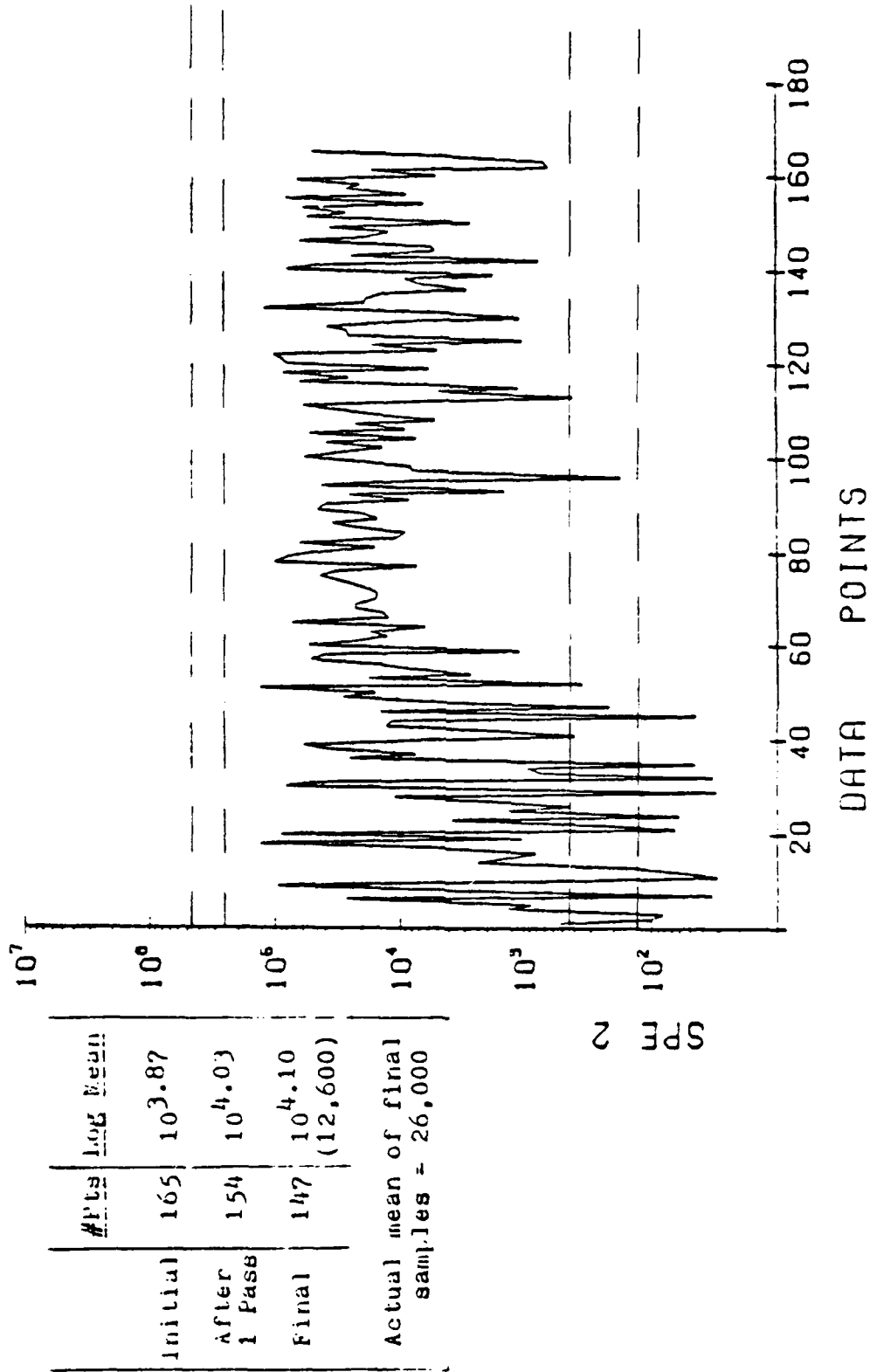

Figure 5. Data Editing in a Bin. Two Pass Rejection Process is Shown.

### 2.1.5 Correlation Analyses

The objectives of the correlation analyses are twofold. First, determine the adequacy of the categorization specified in the distribution analysis. Second, provide input to the model development. That is, once the final categorizations have been determined, the end result, the model, will require logical and functional continuity from one subgroup to another. A number of correlation analyses have been performed, both within and across groups of data. Correlation coefficients have been calculated within 10 and 20 Km. altitude groups and showed negligible dependency within an altitude level.

The adequacy of the partitioning for altitude as well as the other parameters was aided by plots such as Figure 3 where, within a bin, the low correlation between sorted specie density samples and the corresponding controlling parameters could be verified. Mean density values rather than correlation coefficients were calculated to check the adequacy of the latitudinal increments chosen. Portions of the data were grouped into different (smaller) latitudinal bins and means were compared, showing acceptably low trends.

Detailed correlation studies with DST and AE indices suggest that shorter time periods must be considered to obtain the proper relation between AE and density at high latitudes and DST and density at equatorial latitudes.

#### 2.1.6 Revised Grouping and Averaging

An examination of the statistics and preliminary plots indicated marginal, if any, dependency on sunspot number. This is to be expected since most of the values were below 40, with a majority below 20. Further work was conducted without regard to sunspot number.

A more detailed analysis was performed on selected groups. This analysis showed a strong seasonal dependency, particularly at lower altitudes. Hence the data was further grouped to reflect the season by differentiating between north and south latitudes, except for equinox data.

The data were grouped according to the revised bin designations. Data varying greatly from the norm were excluded according to the log-normal editing criterion described above. Averages and standard deviations were calculated and saved for these subsets of data. Further software was written to calculate and save the 25, 50 and 75 percentiles.

Extremely sparse data groups were identified and eliminated. A summary of the edited data set population was provided for each specie and the total density, separated by SZA and Kp ranges. On average, this represents about 93 percent of the preliminary edited data considered in the analysis.

#### 2.1.7 Averaging Summary Profile Plots

To assist in the data presentation and subsequent analysis, software was written to prepare the above output data for processing on the Tektronix. Summary profile plots displayed the resultant density means and the 25 and 75 percentile values over the altitude range. Figure 6 shows typical plots for two

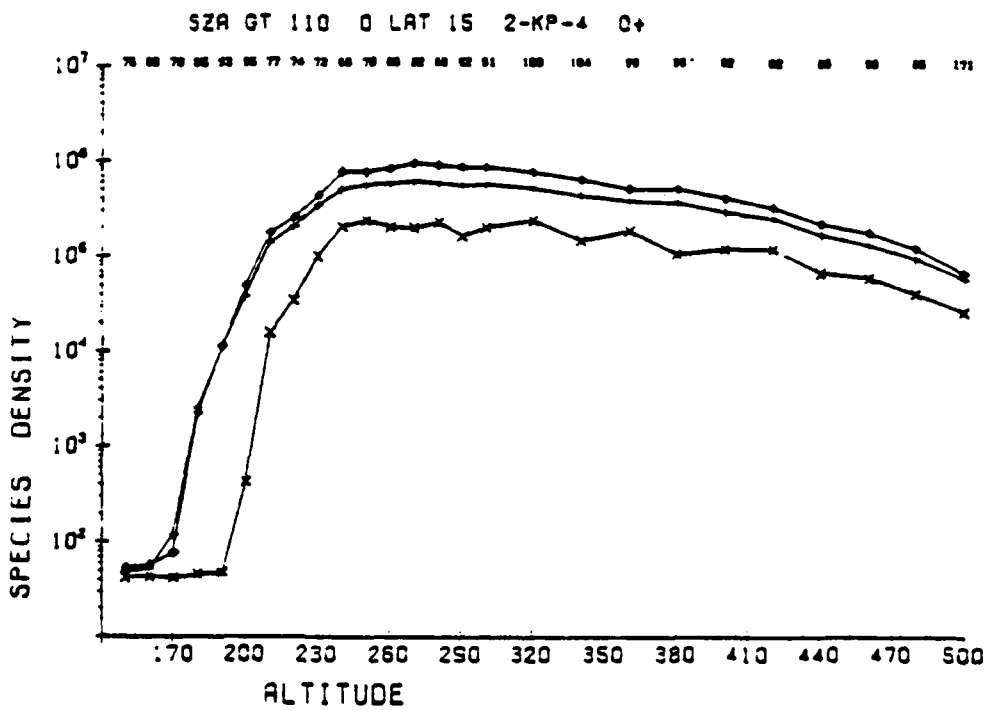
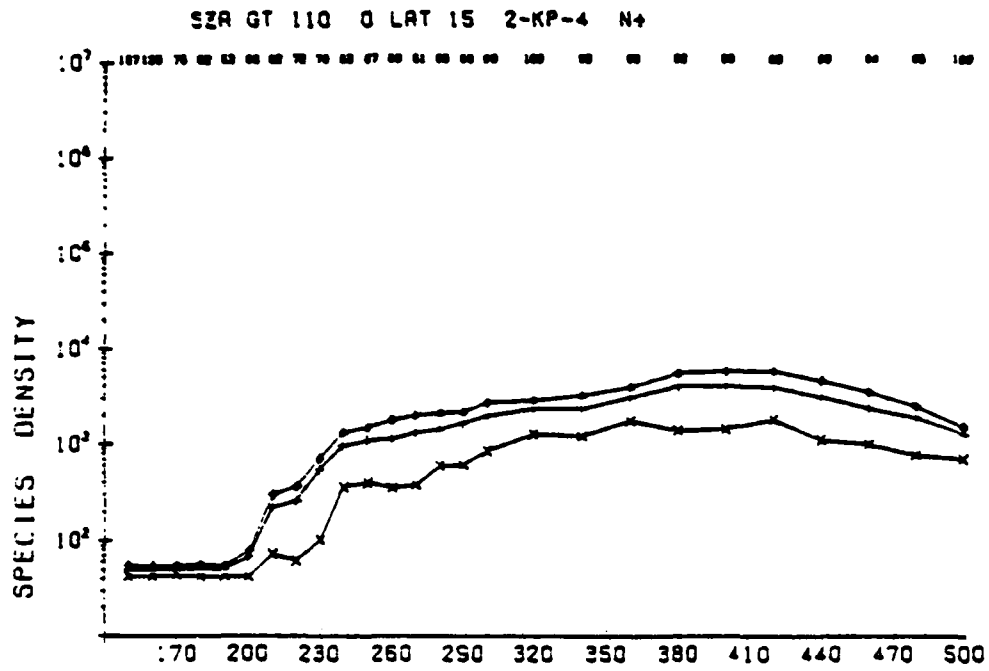

Figure 6. Average, 75 percentile and 25 percentile Profiles for N<sup>+</sup> and O<sup>+</sup> in a Range

constituents. The number of samples comprising each profile point is also presented for easy reference. These plots show that the largest density variations occur where the density gradient is high, and that the mean tends to be close to the 75 percentile value. Plots of the five averaged species plus total density averages bounded by the 25 and 75 percentiles, comprising about 600 plots, were saved on microfiche. This data is also available in tabular form for reference and further analysis. They also serve as a first cut to the ion composition modeling effort.

## 2.2 MODELING INVESTIGATIONS

The procedures employed to aid in model development are described here, and sample results are presented. Three distinct techniques using the S3-1 averaged profiles were employed:

- a) Parametric plots of profiles as a function of the various influencing factors viz. altitude, geomagnetic latitude, Kp and solar zenith angle.
- b) Comparison of the averaged profiles with predictions of existing models; in particular the Rawer model<sup>(3)</sup>
- c) Analytical fitting of profiles by functional forms which attempt to span the range of the influencing parameters, such as the Chapman<sup>(4)</sup> and scale height functions.

For these investigations the averaged set is formatted for easy access of combinations of sets with similar characteristics. Examples for each of the procedures are discussed below.

### 2.2.1 Parametric Profile Plots

For more convenient presentation of parametric effects, mean density data may be combined and displayed as overlaid curves on a single plot. Figure 7 shows two such plots for  $O^+$ . Features and irregularities may now be extensively explored by the investigator.

### 2.2.2 Rawer Model Comparison

A limited number of ion composition and density models are available for comparison with the S3-1 averaged profiles. The Rawer report<sup>(3)</sup> gives electron density and temperature, and ion temperature and composition (percent by specie) for low and mid-latitude, for selected values of the other influencing parameters. Assuming a neutral atmosphere, Rawer electron density data and S3-1 total density profiles were plotted wherever overlapping comparisons were possible.

### 2.2.3 Analytical Fitting of Profiles

The atomic constituents and the total ion density are seen in Figures 6,7 and others, to be representable by a few parameters, as Chapman layer profiles<sup>(2)</sup>.

$$n(h) = a e^{-0.5(1-Y-DZ)} \quad (1)$$

where  $Y = \frac{h-H}{b}$  and  $Z = e^{-Y}$

$h$  is the altitude and  $a, b, H$  and  $D$  are to be determined for a specific density profile. For this function the maximum density is

$$n_{\max} = a / \sqrt{D} \quad (2)$$

which occurs at an altitude given by

$$Y = \ln D \quad (3)$$

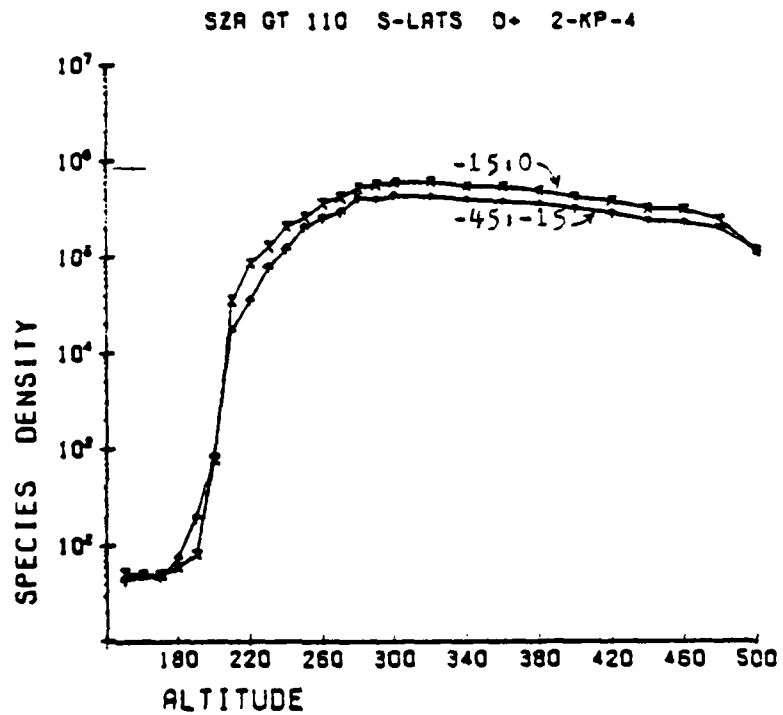
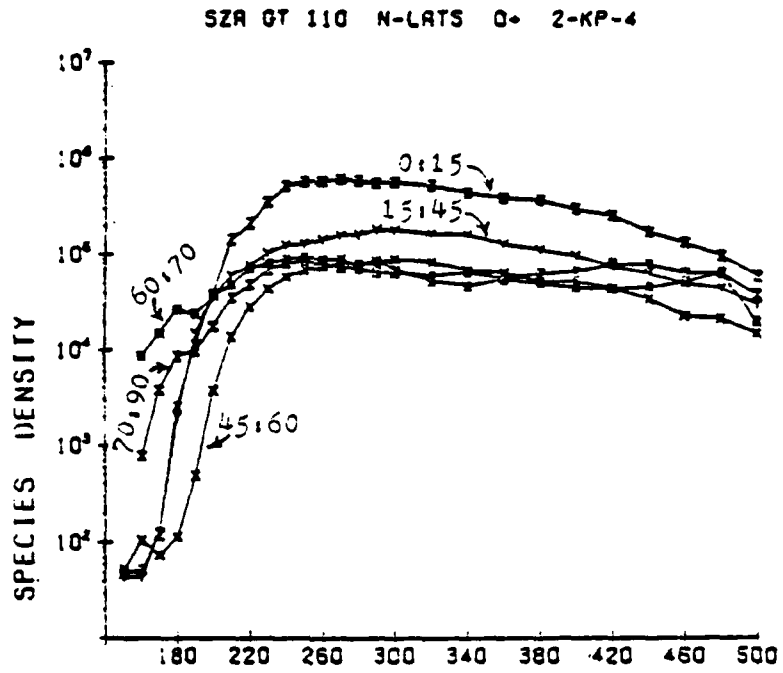

Figure 7. Latitudinal Parametric Profile Plots for  $O^+$  at Night

The maximum density gradient on the bottom ledge occurs at an altitude given by

$$Y = \ln D - 1.317 \quad (4)$$

A number of averaged profiles from various bin categories have been tested for fitting by the Chapman function. Good convergence and fit are obtainable in some of the cases (Figure 8 is an example), but in a number of instances the profile characteristics may warrant modified functional forms to obtain good representation.

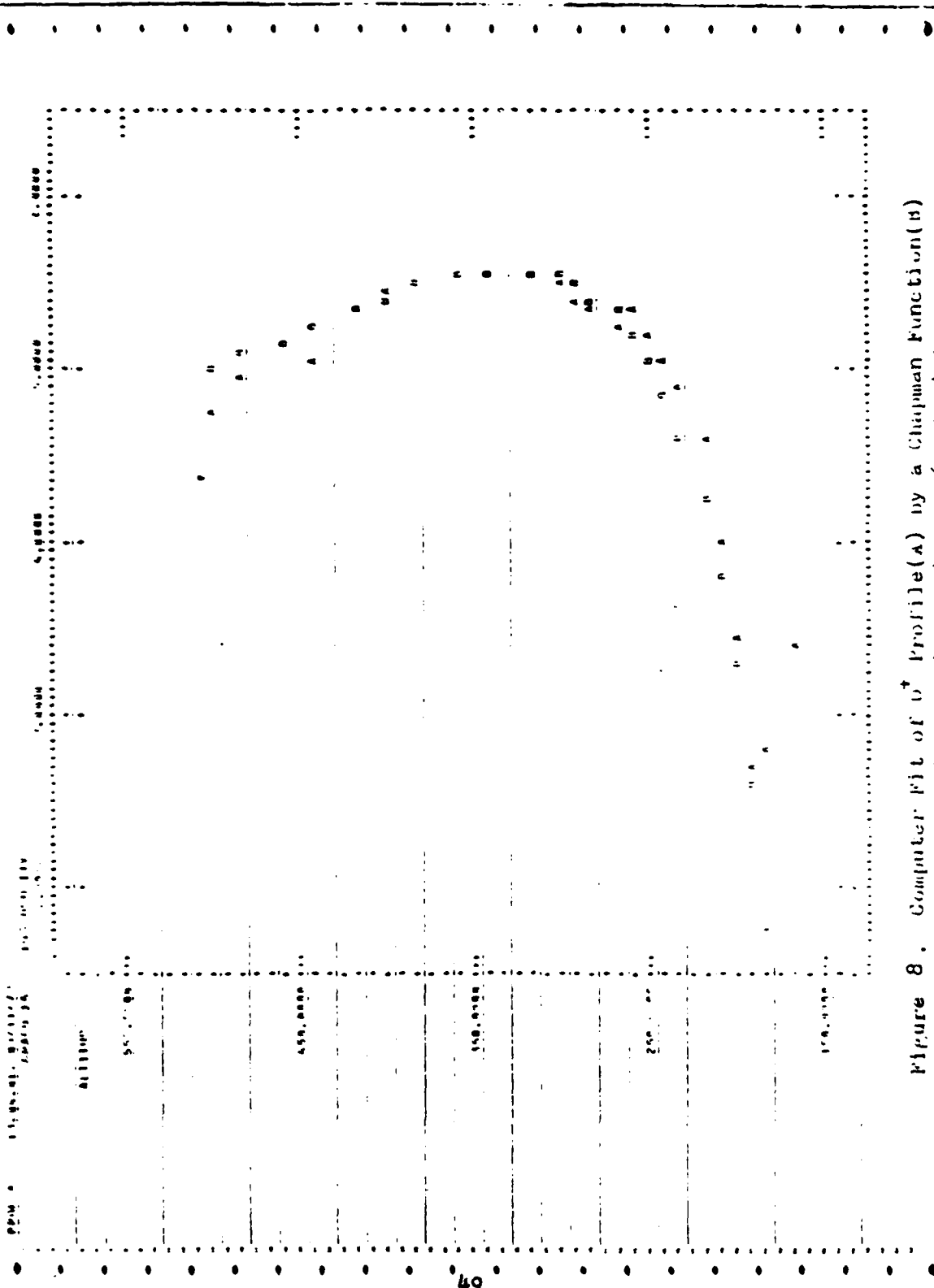

Figure 8. Computer Fit of  $U^+$  Profile(A) by a Chapman Function(B) for SZA 90-110, Latitude -45 to -60, Kp 4-9

## REFERENCES

1. Bhavnani, K.H., McInerney, R.E., Philbrick, C.R., and Ziemba, E.J., "S3-1 Satellite Data Processing Analysis for Ion Composition Modeling of the F Region", AFGL-TM-36 March 1980
2. Delorey, D.E. "Data Base Development for Air Force Satellites", Space Data Analysis Laboratory, Boston College, AFGL-TR-78-0076, March 1978
3. Rawer, K. et al, "Preliminary Reference Profiles for Electron and Ion Densities and Temperatures proposed for the International Reference Ionosphere", Institut fur Physikalische Weltraumforschung, IPW-Scientific Report WB2, July 1975
4. Banks, P.M. and Kockarts, G. AERONOMY Part B, Academic Press, New York, (1973), Ch. 17.

### 3. SUATEK - INTERACTIVE GRAPHICS SYSTEM.

#### 3.1 OBJECTIVES AND IMPLEMENTATION

Experimental data gathered from any number of sources usually require editing and preprocessing prior to performing the final analysis. In many cases this requires numerous computer runs with constant interaction between the scientist and data analyst. It is of prime importance that the editing of available scientific data be done as expeditiously and economically as possible so that the time lag between experiment and data presentation be minimized. Time saved in the editing function can be effectively spent in the data analysis portion of the project. Utilization of visual information display devices coupled interactively with the CDC 6600 can in most cases assist in performing these tasks with the desired savings in time and effort by allowing the scientist to directly interface with his data in a dynamic way.

Hence, to satisfy requirements for flexible data presentation and evaluation by researchers a generalized Tektronix interactive graphics system was developed. This system, SUATEK, facilitates the evaluation, restructuring, as well as augmentation of data bases.<sup>(1)</sup>

Modeling activities, data and mathematical analysis, simulation and optimization studies, along with their associated graphical presentation are facilitated. A standard format data base including a header and data blocks is first generated. This facilitates further manipulation of data for presentation at the console. SUATEK is a system of graphics routines whose primary

function is to enable an individual scientist to perform time consuming data editing and display tasks by allowing him to interact directly with his data base online. These routines provide the user with the capability to display, analyze, and edit a file of data interactively as well as to obtain plots of selected portions of the entire data file. Individual routines were designed in a general way to satisfy many specific requirements and different types of data. The system was designed with the ease of use by the scientist a prime factor so as to minimize the dependency of the user on the data analyst while editing his data base. The system is modular in design so that individual routines can be used in different combinations. Thus a particular set of data may be processed by grouping editing operations into a logical sequence.

SUATEK operates on the users data base which must be set up as a permanent file by a batch job. A functional flow of the user data and the interaction with the graphics software is given in Figure 1. The user chooses which X,Y pair or multiple Y (up to four), X pairs to be displayed on the screen. He may choose the scales of the X and Y axes and the interval of data to be displayed, or let the program calculate the scales over the interval. Y axis data can be displayed in a linear or logarithmic fashion. A repeat factor is used to determine how many data points are to be displayed. An important feature of SUATEK is that data may be edited from either the display or the data base. This gives the user the capability of displaying only a fraction of his data but the ability to edit from the whole data base. Hard copy

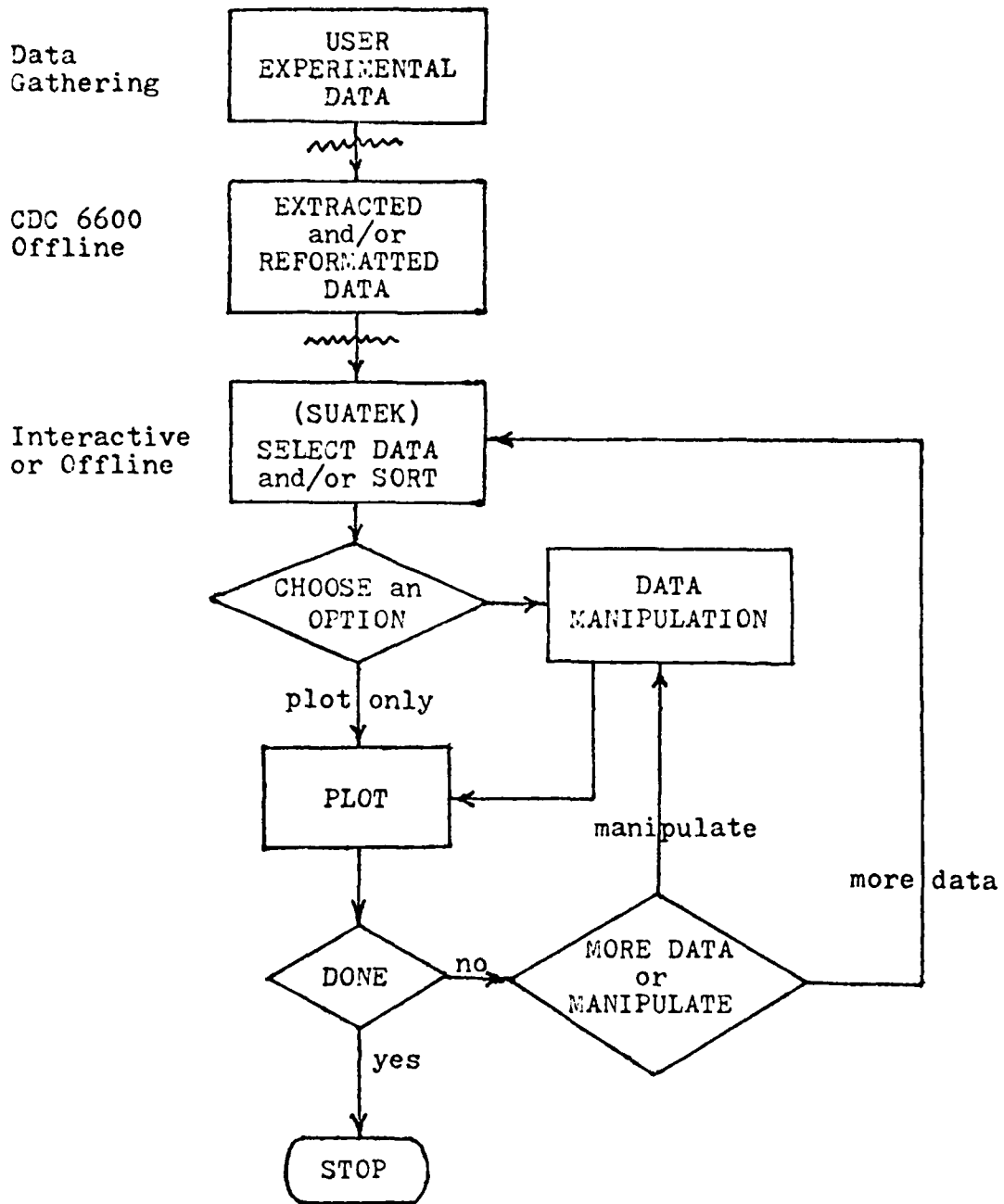

FIGURE 1. FUNCTIONAL FLOW OF SUATEK

plots can be made of data displayed on the screen at any time during the processing.

The SUATEK package allows for keyboard identification of variables and ranges to be plotted, followed by appropriate labelling of the plot range. Although plots are generated via responses to program queries, a "clean copy" plot is available. That is, once the subset of the available data has been chosen, labeled and manipulated, it can be redisplayed without the queries and responses necessary to generate the original plot. Among the features available in the software are the following capabilities:

- 1) plot points and/or connected line on a semilog or linear scale
- 2) plot negative numbers on a semilog scale as  $-\log |x|$
- 3) edit out specific points
- 4) display points only within certain ranges
- 5) display points for one parameter as a function (within certain ranges) of another
- 6) add data points
- 7) obtain and display a polynomial curve fit of displayed data
- 8) calculate and display running averages of the data base

This package facilitates quick looks at the data as well as processing of the data and displaying of the manipulated data. However, it may be desirable to generate a large amount of plots based upon results and procedures defined in an interactive mode. Provisions for numerous noninteractive plots have been accomplished. A subset of the interactive graphics software has been

extracted to obtain plots in three other manners,  
They are

- 1) pen and ink ON-LINE plots
- 2) MICROFICHE
- 3) TEKTRONIX without user interaction

### 3.2 ON-LINE SUATEK User's Guide

SUATEK is an interactive graphics application program which allows the user to display data on the Tektronix graphic screen under a number of plot options in conjunction with data manipulation options. The user must supply his own data in a prescribed format. SUATEK was written using the standard plot routines available for plotting on the other AFGL facilities. The interactive portion, queries and responses, uses list directed input and output. The standard functions, eg. axis labeling, plotting of points, uses the subroutines available for plotting on any AFGL plot device. Since only 65K of core is available in the interactive mode, the program uses overlays to minimize the amount of core required for execution.

Input/output buffers as well as data arrays are limited to 512 words. Certain features, eg. the plotting of the entire data set with or without running averages, have been included without the 512 points restriction. However, for most of the functions a maximum of 512 data points can be processed at once. SUATEK is the basis of various off-line programs which need not have the size limitation. The primary functions of SUATEK are the following:

- 1-retrieve data, plot
- 2-retrieve data, sort data based on X, plot
- 3-sort values in core based on X, plot
- 4-plot data in core
- 5-clean copy, assumes all labels determined,  
data in core and manipulated
- 6-repeat factor change
- 7-axis length change
- 8-zoom option
- 9-data edit
- 10-calculate running average
- 11-linearly combine variables
- 12-polynomial curve fit
- 13-retrieve data, calculate running average, plot
- 14-save data displayed on screen
- 15-update data files

Data retrieval and plots assume one X-variable vs. up to four Y-variables. Axis lengths, minimums, scales, offsets, repeat factors and plot type (semi-log or linear) may be user chosen at time of input, or allowed to be preset and/or calculated by the program.

### 3.2.1 PROGRAM FLOW

The flow of the program is directed through the main overlay. This overlay

- 1) presets the default values
- 2) initializes the plot
- 3) displays the primary program query
- 4) directs the activities to the proper functions
- 5) terminates the program

At the conclusion of any activity or grouped activities the program returns to the main overlay for further direction. The following is a list of default values

X- axis variable=data array subscript 1  
Y- axis variable=data array subscript 2  
(only one Y variable)

REPEAT FACTOR=1  
axis length=8 inches  
axis offset=0 inches  
minimum value (program calculated)  
scale factor (program calculated)  
linear plot

(Default values apply to both X and Y axes)

The other overlays, of which there are ten were written to perform the various functions individually or in conjunction with other overlays. As the code evolved certain redundancies were built into the program. Rather than eliminate these redundancies, they have been retained to provide greater user flexibility.

The ten functional overlays are the following:

- 1 DATZ
- 2 REPT
- 3 LENH
- 4 ZOOM
- 5 PLTE
- 6 EDIT
- 7 RUNN
- 8 AVDT
- 9 CURF
- 10 MERG

### 3.2.1.1 DATZ

DATZ is used to retrieve the desired portions of the data available. The default labels, those which are read from stored data, are extracted and saved for later use in overlay PLTE (the plotting overlay). Overlay DATZ queries the user to determine which section of data, dependency variable, if any, and range of dependency is desired. For the situation where the entire data set is to be read and plotted on a single plot, ( data set greater than 512 points) code was written to handle this case. DATZ can be used in conjunction with overlay RUNN to obtain data **retrieval and running averages in** one data activity directive. Further, the data sort option is directed through this overlay. For all of the aforementioned activities the program is directed to plot the resultant data.

### 3.2.1.2 REPT and LENH

REPT is used to change the repeat factor. The user is queried for the new desired repeat factor. LENH is used to change the length of the X and all Y axes. Any or all of these axes lengths can be changed. A response for each axis is expected. If no change for a displayed axis is desired, the original length must be retyped.

The functions performed by these two overlays are redundant. The same results can be obtained through responses to the primary queries

" ENTER ICODE IACT JA "

" ENTER LENGTH MIN SCALE OFFSET "

which appear at the conclusion of every activity.

### 3.2.1.3 ZOOM

The purpose of the ZOOM overlay is to establish a new range of data to be displayed. The new range is by definition smaller than the original. Hence the result is a blow-up of a portion of the plot being displayed. Two methods of determining the new range are available. They are 1) using the crosshairs or 2) typing in the range of values. Although both methods generate both X and Y ranges the blow up is keyed on the X values only. After the new range has been established a call to the PLTE overlay is necessary. Further, if the default minimum and scale is not in use, a resetting of these values will be necessary.

### 3.2.1.4 PLTE

The PLTE overlay is used to plot and label the desired data. The user has the choice of keying in new labels or using the ones obtained when the data was retrieved. Further, range specification for both the X and Y parameters are available. Hence data zooming is possible through an alternative method (Implicitly, data truncation is possible). This overlay will plot

- 1) either linear or semilogarithmic
- 2) if desired, negative numbers are plotted on a semilog scale as  $-\log |Y|$
- 3) points only within certain ranges

At the conclusion of any plot the query "SAVE DATA l=YES" is displayed. If "1" is typed in, the displayed data is saved for future analysis and manipulation.

### 3.2.1.5 EDIT

The EDIT overlay provides for the deletion, addition and/or resetting of data. This overlay is similar to the ZOOM overlay in that both allow for crosshair and keyboard input. For replacement/deletion, two messages and responses are necessary. Data can be added only through the keyboard. Any amount of data up to the maximum array size of 512 is allowed. In the replacement mode a choice of linear interpolation or keyboard setting of data is available. Linear interpolation or data value definition is done to the Y-values for the X range determined. A code value, specifically the value -99., is used to delete data points. For all X values assigned the value -99., the corresponding Y-values will be deleted. For any option the new set of values including replacements or deletions will be sorted and plotted.

### 3.2.1.6 RUNN

The running average overlay RUNN calculates the running average (for X and all Y, up to four, variables) of either a segment of data or the entire data set available. The segment restriction is 512 points. The maximum number of values which may be averaged is 50 for the online version, 120 for the off-line version. Future modification may allow for the averaging of values over an interval greater than 512 but less than the total data set. This function may be called in two fashions. The first option assumes data in core and does not automatically plot the data. The second option first reads the data before averaging, then plots the averaged data.

#### 3.2.1.7 AVDT

To provide a method of summing or combining a set of variables overlay AVDT was incorporated. A single variable can be operated upon, hence the result of this function in that case is to scale the variable. One prompting query is used per variable to obtain the scale factors. The query and response is repeated up to the number of Y-values in core. The resultant modification is placed in the first Y-array. The number of Y-variables is set to one. No automatic plot is generated.

#### 3.2.1.8 CURF

To obtain a polynomial curve fit of any of the data plots displayed, overlay CURF was incorporated. This function uses routines obtained from the IBM Scientific Subroutine package. Normal equations for a polynomial least-squares fit to the discrete function defined by the X-Y plot are determined and solved. The curve fitting polynomial is computed in terms of its Chebyshev expansion. At present, the curve fitting polynomial can be at most of degree 10. Once the coefficients of the polynomial are calculated, a set of Y-values are determined and saved in the first Y-array. The number of Y variables is not reset to one, and a plot is not automatically generated.

#### 3.2.1.9 MERG

To facilitate the updating of data sets, overlay MERG was incorporated. To acquire the updated data set, requesting a TAPE2 permanent file before loading

and cataloging the file required. A new file is created in SUATEK format. The option to increase the variable indicating how many data records are present was incorporated. Further, the option to delete data records or preset values on the data file to a specified value has been incorporated.

### 3.2.2 INPUT/OUTPUT

Input is provided to SUATEK via two devices, permanent file (TAPE1) and keyboard. TAPE1 is a binary file prepared by the user prior to SUATEK load. The structure of TAPE1 is as follows:

Record 1 header variables

NOV (integer)--number of variables in each data record, maximum of 34

MN (integer)--number of data records

LAE (integer)--if  $\neq$  0 header records present

MLA (integer)--if  $\neq$  0 min and max of variables available before data values (usually in record 3)

LBL (alphanumeric)--header array, three label words per variable, may be totally or partially blank

Record 2-MLDL-five words of additional header information, optional

Record 3 (DM,DX) min and max values for each of the data variables (Read in program by READ(1) (DM(I),DX(I), I=1, NOV))

Record 4 to MN+3--Data Values

Data array, maximum of 34. Number of values in array must agree with NOV

Although there are certain default values, the program was written to obtain instructions via the keyboard. All

of the overlays display queries whose responses are necessary to perform the individual functions. Numeric codes and activity designations direct the flow of the program. One prompting query which should be emphasized is the one displayed in the main overlay

"ENTER ICODE IACT JA"

This query is displayed at the completion of every activity. The expected responses for variables ICODE, IACT, JA are the following

- ICODE 1 indicates X-axis parameter information on response
- ICODE 2 indicates first Y-axis parameter information on response
- ICODE 3 indicates additional Y-axis parameter information on response
- ICODE 4 indicates activity to be determined by IACT value
- ICODE 5 special function used when more than one plot is displayed. IACT value determines which plot will be displayed by itself on an 8 x 8 display.

For ICODES 1,2,3

IACT = subscript of value on TAPE1 to be used as X or Y value.

On the X definition response (ICODE = 1)

JA = repeat factor

When defining Y variables (ICODE = 2 or 3)

JA = 0 values are displayed as unconnected symbols on a linear scale

JA = 1 values are displayed as unconnected symbols on a log scale

- JA = 2 values are displayed as connected points on a linear scale
- JA = 3 values are displayed as connected points on a log scale
- JA = 4 values are displayed as connected symbols on a linear scale
- JA = 5 values are displayed as connected symbols on a log scale

For ICODE=1, X-definition, the query

"ENTER LENGTH MIN SCALE OFFSET SUBFRAME"

will appear to define variables A, B, C, D, JSF

- A- length of axis, default 8 inches
- B- minimum value, default program calculated  
(If B=-9.9 the optional minimum and maximum values on TAPE1 are assumed present and are used for axis determination)
- C- scale factor, default program calculated
- D- offset from origin, default 0.0

JSF- If=0 (default) standard X-Y plots are produced

If=1, then the poor man's contour display is assumed, i.e. Z values are entered as numbers on an X-Y plot.

For JSF=1 the query "ENTER FUDGE SLOPE,INTER"

will appear. The values SLOPE and INTER will scale each data value VAL by the following algorithm

$$VAL = (VAL-INTER)/SLOPE$$

The array of values VAL is entered into the second Y-variable array. These form the Z values which are entered as numbers on a plot of X vs. the first Y array.

For ICODE = 2 or 3, the query

"ENTER LENGTH MIN SCALE OFFSET"

will appear to define variables A, B, C, D

The definitions and defaults are the same as for X-definition (ICODE=1) with JSF=0. When JSF=1 i.e. in the contour case no input is required when entering the 2nd Y-value.

For ICODE = 4, IACT determines the activity as follows

List of activities - IACT values

- 1 - obtain data, no sort, plot
- 2 - obtain data, sort on X, plot
- 3 - sort values in core based on X, plot
- 4 - plot data in core
- 5 - clean copy, assumes all labels and data previously determined
- 6 - repeat factor change
- 7 - length of axis change
- 8 - data ZOOM
- 9 - data EDIT
- 10 - stop program
- 11 - calculate running average of data displayed
- 12 - linearly combine variables
- 13 - curve fit
- 14 - obtain data, calculate running average, plot.
- 15 - merge saved data with old data set, save resultant data

The only output of SUATEK is the graph displayed on the TEKTRONIX screen. Hard copy output of the plot displayed is available. The hard copy is smaller than the screen display. The entire screen 11" X 14" is copied onto a 8½" X 10" page. Hard copy data is approximately 50% of screen display. Figure 2 is an example of the hard copy output which permits ready comparison of raw and fitted data. Figures 3,5,6 and 7 of Section 2 were also obtained using SUATEK.

### 3.3 OFF-LINE SUATEK User's Guide

#### 3.3.1 OVERVIEW

SUATEK in its present form is a useful analysis tool. Planned future modifications and expansions will provide an even more powerful analysis tool. The question "Why are off-line versions necessary?" may be asked. Two reasons were addressed in the program limitations section of the interactive SUATEK report:

- 1) size limitations, primarily array limitations
- 2) resultant plots may not be suitable for publication

The off-line versions use arrays with a maximum of 2000 points and could be easily expanded in the future. A typical Tektronix hard copy plot will contain both the queries and responses. This together with the normal shrinkage, makes use of these plots difficult for publication. A clean, full scale or blow-up plot can be obtained off-line.

INTENSITY VS. WAVELENGTH

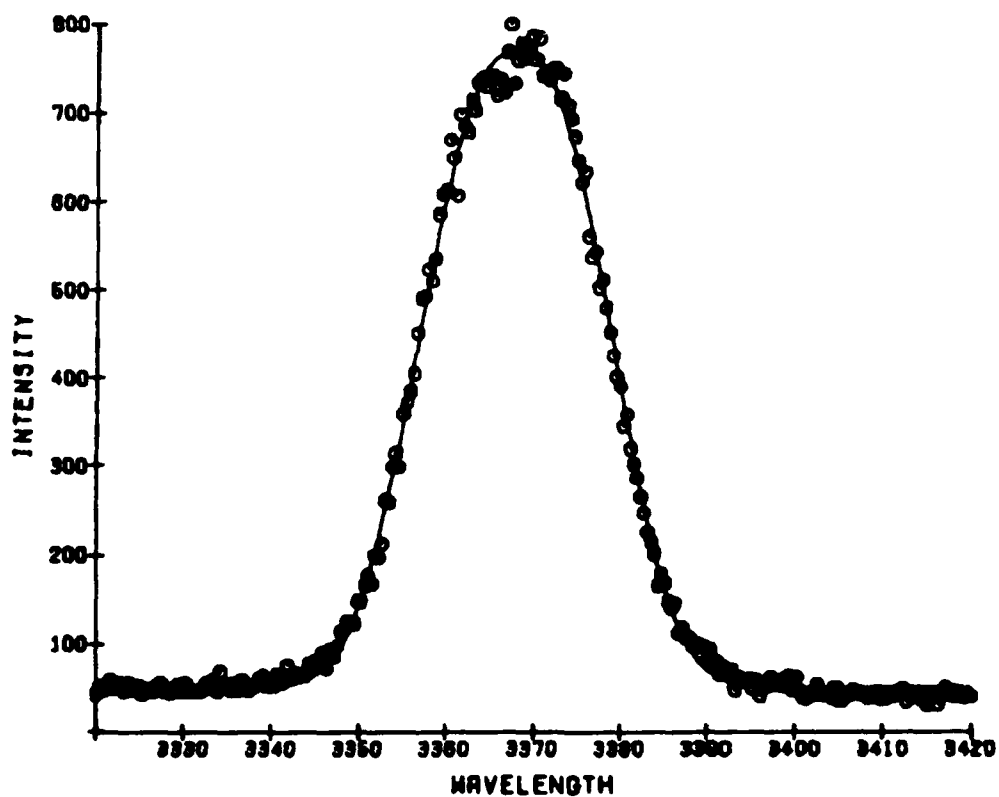

Figure 2. Hard Copy of SUATEK Plot generated on Tektronix display. Two Y variables (data points and a fitted function) are plotted vs. one X variable.

A third and probably more important reason for having available off-line versions is the time element. Often it requires 20-30 minutes to obtain a plot of data. If a number of these plots were desired, the person interface time would be prohibitive. The off-line versions allow for production runs to be processed once plot criteria have been established while using SUATEK earlier in the interactive mode.

A fourth reason would be to eliminate the interactive options. Presently the capability to modify and check-out any off-line plotting programs is available with a minimum of user directives. SUATEK can be run in this fashion to check-out small changes or to generate a small number of well-defined plots.

At present, there are three off-line versions of SUATEK. The object codes reside on permanent files. The three versions are

- 1) Tektronix off-line
- 2) Pen and Ink
- 3) Microfiche

All three obtain their plot definition input via punch cards. (The user data set resides on file TAPE1). They differ only in the control cards necessary to access the AFGL plot facility and the respective plot routines necessary for the different plot outputs. For example, Microfiche program requires CALL MICRO (X,Y,Z) instead of CALL PLTID3 (X,Y,Z,W). The Tektronix off-line version may be obtained by using the object code of either the Pen and Ink or Microfiche versions together with the control cards described.

### 3.3.2 Functional Description

The off-line version of SUATEK is a graphics application program which allows the user to display data on the Tektronix graphic screen, microfiche or pen and ink plotter in conjunction with data manipulation options. The user must supply his own data in a prescribed format. All SUATEK versions were written using the standard plot routines available for plotting other AFGL facilities. The standard functions, eg. axis labeling, plotting of points, uses the subroutines available for plotting on any AFGL plot device. The program uses overlays to minimize the amount of core required for execution.

At present the input/output buffers as well as data arrays are limited to 2000 words. Certain features, eg. the plotting of the entire data set with or without running averages, have been included without the 2000 points restriction. However, for most of the functions a maximum of 2000 data points can be processed at once. The primary functions of the off-line SUATEK program are a subset of the functions available interactively. They are:

- 1- retrieve data, plot
- 2- retrieve data, sort data based on X, plot
- 3- sort values in core based on X, plot
- 4- plot data in core
- 5- retrieve data, calculate running average, plot

Date retrieval and plots assume an X-variable vs. up to four Y-variables. Axis lengths, minimums, scales, offsets, repeat factors and plot type (semi-log or linear)

may be user chosen via the input cards or calculated by the program.

### 3.3.3 Program Flow

The flow of the program is directed through the main overlay. This overlay

- 1) presets the default values
- 2) initializes the plot
- 3) directs the activities to the proper functions
- 4) reads card input data
- 5) terminates plots and program

At the conclusion of any activity the program returns to the main overlay for further direction. The following is a list of default values

X-axis variable = data array subscript 1

Y-axis variable = data array subscript 2

REPEAT FACTOR = 1

axis length = 8 inches

axis offset = 0 inches

minimum value (program calculated)

scale factor (program calculated)

linear plot

(Default values apply to both X and Y axes.)

These same default values are used in the interactive versions.

The overlays extracted and at most slightly modified for usage in the off-line version are the following:

1. DATZ
2. PLTE
3. RUNN

#### 3.3.4 Input Format and Control Cards

CARD 1 SCALE FACTOR

FORMAT (F10.3)

CARD 2 TITLE CARD

FORMAT (3A10)

CARDS 3 + 4 Additional title information used on  
Microfiche version only

FORMAT (7A6)

CARDS 5 etc. Variable or Activity definition

FORMAT (I1,I2,I1,F3.1,2F8.0,F3.1,I2,2F8.1,2I7,I2,2F7.1,I1)

Data on these definition cards differ in their usage,  
depending upon whether they are on an X-definition,  
Y-definition, or an Activity card.

These cards are described on the following pages.

X - definition card variables

Cols	Format	
1	I1	ICODE - must be set to "1"
2-3	I2	IACT - TAPE1 variable subscript, becomes X parameter
4	I1	JA - repeat factor (default 1)
5-7	F3.1	A - X-axis length (default 8 inches)
8-15	F8.0	B - X-min value (default program calculated)
16-23	F8.0	C - X-scale factor (default program calculated)
24-26	F3.1	D - X - axis offset (default 0)
27-28	I2	ISF - if =1 additional header information available on TAPE1 second record
29-36	F8.1	ZMN - minimum X-value of interest
37-44	F8.1	ZMX - maximum X-value of interest
		{blank to consider all values
45-51	I7	JST - first record of TAPE1 to be processed, if 0 all data processed
52-58	I7	JSP - last record of TAPE1 to be processed
59-60	I2	KPRM - dependency parameter, if = 0 no dependency, if ≠ 0 then subscript of independent variable
61-67	F7.1	ZPN - minimum value of independent variable to be considered
68-74	F7.1	ZPX - maximum value of independent variable to be considered
75	I1	IAL - if =1, then next card, first 30 columns will be the X-axis label

Y - definition card variables

Cols	Format	
1	I1	ICODE - 2 for first Y variable 3 for additional Y variables allowed.
2-3	I2	IACT - TABLE variable subscript, becomes Y parameter
4	I1	JA - = 0 linear scale, unconnected symbols = 1 log scale, unconnected symbols = 2 linear scale, connected points = 3 log scale, connected points = 4 linear scale, connected symbols = 5 log scale, connected symbols
5-7	F3.1	A - Y-axis length (default 8 inches)
8-15	F8.0	B - Y-min value (default program calculated)
16-23	F8.0	C - Y-scale factor (default program calculated)
24-26	F3.1	D - Y-axis offset (default 0)
29-36	F8.1	ZMN - minimum Y-value of interest
37-44	F8.1	ZMX - maximum Y-value of interest
45-51	I7	JST - first two digits, columns 45-46, used to calculate running average (last five digits not used at present)
75	I1	IAL - if = 1, then next card first 30 columns will be the Y-axis label

Activity Card Variables

Cols	Format	
1	I1	ICODE - either a "4" or "6", if = 4, only one plot to be generated if = 6, multiple plots to be generated
2-3	I2	IACT - activity of interest Similar to BUATEX definition, however some activities were deleted. Remaining activities are the following:  1) obtain data, no sort, plot 2) obtain data, sort on X plot 3) sort values in core based on X, plot 4) plot data in core uses labels established on TAPE 1 definition 5) same as 4 10) stops program 14) obtain data, calculate running average plot
4	I1	JA - if $\neq$ 0, then header information read in from next card with Format (5A10), and plotted at top of output plot

Note: If ICODE = 6, then data are assumed to be stacked,  
i.e. multiple files of data and successive plots are  
to be generated using the same X,Y (or multiple Y's)  
information. The number of stacked files is defined  
by the JSP integer parameter, columns 52-58.

CONTROL CARDS

The control cards necessary to run the above off-line revisions are the following: (CM 77700g required)

TEKTRONIX

ATTACH, LGO, OFLSP, ID=SUWA. (or OFLSM)  
ATTACH, TAPE1, -----  
ATTACH, TEK, TEKOFFLINE.  
REQUEST, T4Ø140, \*PF.  
ATTACH, AA, PLOTLIB.  
LIBRARY, AA, TEK.  
LGO.  
CATALOG, T4Ø140, -----

PEN and INK VERSION

ATTACH, LGO, OFLSP, ID=SUWA.  
ATTACH, TAPE1, -----  
ATTACH, AAA, PLOTLIB.  
ATTACH, PEN, ONLINEPEN.  
REQUEST, PLOT, \*Q.  
LIBRARY, PEN, AAA.  
ROUTE, PLOT, DC=PL, DEF.  
LGO.

MICROFICHE VERSION

ATTACH, LGO, OFLSM, ID=SUWA.  
ATTACH, TAPE1, -----  
ATTACH, AAA, PLOTLIB.  
ATTACH, AA, CRTPLOTS.  
LIBRARY, AA, AAA.  
REQUEST, TAPE 39, \*Q.  
DISPOSE, TAPE 39, FM. (DC=76)  
LGO.

## REFERENCES

1. Ziemba, E.J. and McInerney, R.E., "SUATEK - An Interactive Graphics Program", AFGL-TM-22, August 1979.

**LMED**  
**-8**