

DTNSRDC/SME-80-45

THE EFFECT OF VELOCITY ON SULFIDE-INDUCED SEAWATER CORROSION
OF COPPER-BASE CONDENSER ALLOYS IN AERATED SEAWATER

DDC FILE COPY,

AD A090035

NAVAL

12

DAVID W. TAYLOR NAVAL SHIP
RESEARCH AND DEVELOPMENT CENTER

Bethesda, Maryland 20084



THE EFFECT OF VELOCITY ON SULFIDE-INDUCED
CORROSION OF COPPER-BASE CONDENSER
ALLOYS IN AERATED SEAWATER

By

H. P. Hack
David W. Taylor Naval Ship R&D Center

and

T. S. Lee and D. G. Tipton
LaQue Center for Corrosion Technology
International Nickel Company
Wrightsville Beach, NC

DTIC
SELECTED
OCT. 7. 1980
D

APPROVED FOR PUBLIC RELEASE: DISTRIBUTION UNLIMITED.

SHIP MATERIALS ENGINEERING DEPARTMENT
RESEARCH AND DEVELOPMENT REPORT

September 1980

DTNSRDC/SME-80-45

80 10 7 062

MAJOR DTNSRDC ORGANIZATIONAL COMPONENTS

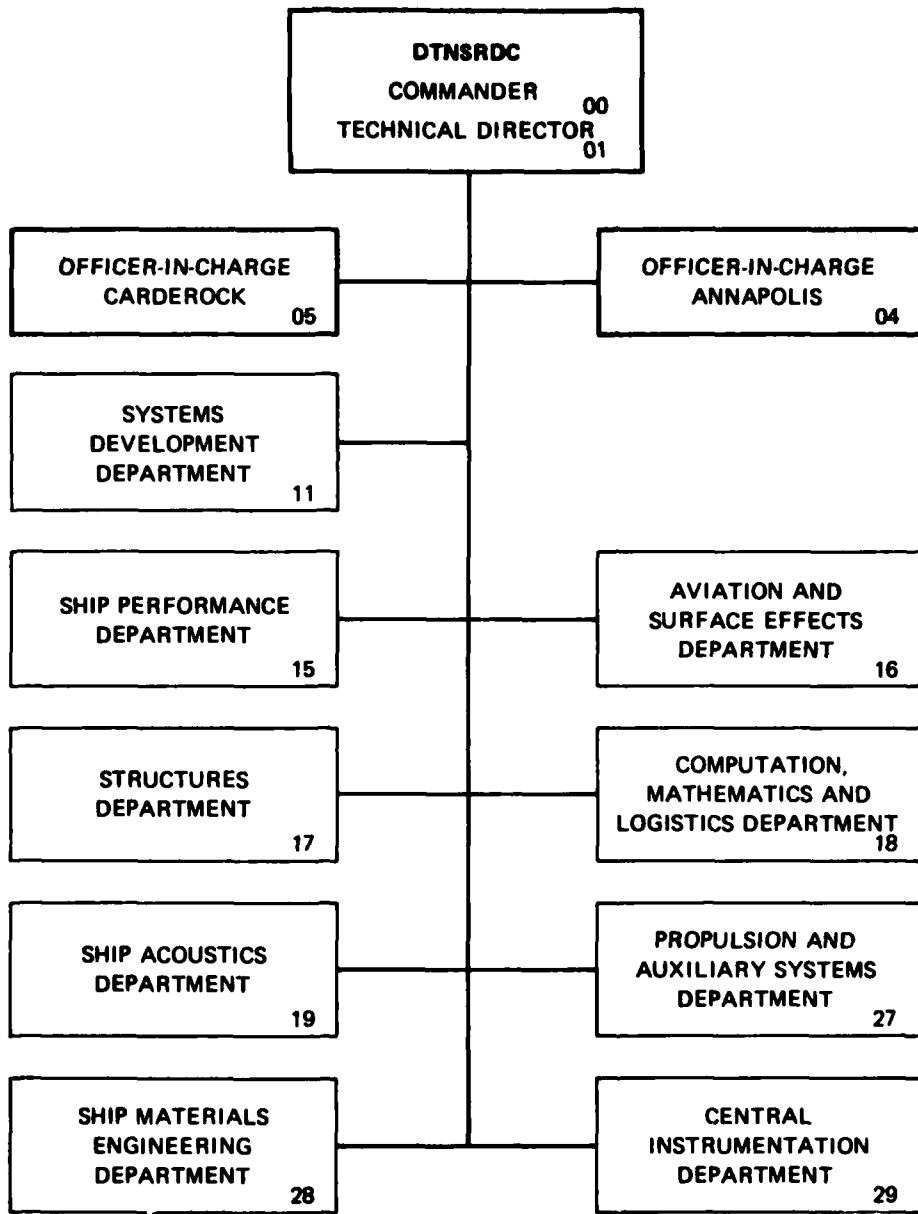

UNCLASSIFIED

Research and development report

SECURITY CLASSIFICATION OF THIS PAGE (When Data Entered)

| REPORT DOCUMENTATION PAGE | | READ INSTRUCTIONS BEFORE COMPLETING FORM |
|---|-------------------------------------|--|
| 1. REPORT NUMBER 14 DTNSRDC/SME-80-45 | 2. GOVT ACCESSION NO. AD-A090035 | 3. RECIPIENT'S CATALOG NUMBER |
| 4. TITLE (and Subtitle) 6 THE EFFECT OF VELOCITY ON SULFIDE-INDUCED CORROSION OF COPPER-BASE CONDENSER ALLOYS IN AERATED SEAWATER . | | 5. TYPE OF REPORT & PERIOD COVERED |
| 7. AUTHOR(s) 10 H. P./Hack DTNSRDC T.S./Lee and D.G./Tipton LaQue Center for Corrosion Technology, Wrightsville Beach, NC | | 8. CONTRACT OR GRANT NUMBER(s) 16 F61541 |
| 9. PERFORMING ORGANIZATION NAME AND ADDRESS David W. Taylor Naval Ship R&D Center Annapolis, Maryland 21402 | | 10. PROGRAM ELEMENT, PROJECT, TASK AREA & WORK UNIT NUMBERS 17 PE62761N SF61541 591 Work Unit 2803-140 |
| 11. CONTROLLING OFFICE NAME AND ADDRESS David W. Taylor Naval Ship R&D Center Bethesda, Maryland 20084 | | 12. REPORT DATE 11 Sep 1980 1980 |
| 14. MONITORING AGENCY NAME & ADDRESS (if different from Controlling Office) 12 3A | | 13. NUMBER OF PAGES 24 |
| | | 18. SECURITY CLASS. (of this report) UNCLASSIFIED |
| | | 15a. DECLASSIFICATION/DOWNGRADING SCHEDULE |
| 16. DISTRIBUTION STATEMENT (of this Report) APPROVED FOR PUBLIC RELEASE: DISTRIBUTION UNLIMITED. | | |
| 17. DISTRIBUTION STATEMENT (of the abstract entered in Block 20, if different from Report) | | |
| 18. SUPPLEMENTARY NOTES | | |
| 19. KEY WORDS (Continue on reverse side if necessary and identify by block number) Copper-nickel alloys Seawater corrosion Sulfide-induced corrosion Pollution Seawater condensers Condenser tubes | | |
| 20. ABSTRACT (Continue on reverse side if necessary and identify by block number) The combined influence of low-level sulfide pollution in seawater and water velocity on several copper base condenser alloys was investigated. The alloys studied included 90-10 copper-nickel (C70600), 70-30 copper-nickel (C71500), IN838 (C72200), and aluminum-brass (C68700). Thin specimens of these alloys were exposed in a nonrecirculating test loop to aerated natural seawater containing additions of sodium sulfide. Sulfide concentration were (See reverse side) | | |

DD FORM 1 JAN 73 1473

EDITION OF 1 NOV 65 IS OBSOLETE
S/N 0102-LF-014-6601

UNCLASSIFIED
SECURITY CLASSIFICATION OF THIS PAGE (When Data Entered)

410/...

UNCLASSIFIED

SECURITY CLASSIFICATION OF THIS PAGE (When Data Entered)

Item 20 (Continued)

0.0, 0.01, 0.05, and 0.10 milligram per liter and dissolved oxygen levels were nominally 80% of air-saturated values. The effect of change in flow velocity in the range of 0.5 to 4.0 meters per second on sulfide-induced accelerated corrosion was studied over test durations of 30-90 days. The amount of sulfide-induced corrosion on C70600 and C71500 was found to depend primarily on the interaction between sulfide concentration and velocity, with the effect of either variable being minimum when the other was low. The variation of sulfide induced corrosion of C72200 and C68700 with sulfide concentration and velocity was found to be much more complex, possibly due to the chromium, aluminum or zinc additions.



UNCLASSIFIED

SECURITY CLASSIFICATION OF THIS PAGE (When Data Entered)

TABLE OF CONTENTS

| | Page |
|--------------------------------------|------|
| LIST OF FIGURES | iii |
| LIST OF TABLES | iii |
| LIST OF ABBREVIATIONS | v |
| ABSTRACT | 1 |
| ADMINISTRATIVE INFORMATION | 1 |
| INTRODUCTION | 1 |
| EXPERIMENTAL PROCEDURE | 2 |
| MATERIALS | 2 |
| APPARATUS | 3 |
| RESULTS AND DISCUSSION | 4 |
| CONCLUSIONS | 13 |
| REFERENCES | 21 |

LIST OF FIGURES

| | |
|---|----|
| 1 - Exposure Loop | 15 |
| 2 - Exposure Loop for Control Specimens | 16 |
| 3 - Estimated Corrosion Rates for C70600 Specimens Obtained by Cross-Plotting Regression Equations | 17 |
| 4 - Estimated Corrosion Rates for C71500 Specimens Obtained by Cross-Plotting Regression Equations | 18 |
| 5 - Estimated Corrosion Rates for C72200 Specimens Obtained by Cross-Plotting Regression Equations | 19 |
| 6 - Estimated Corrosion Rates for C68700 Specimens Obtained by Cross-Plotting Regression Equations | 20 |

LIST OF TABLES

| | |
|--|----|
| 1 - Composition and Processing of Test Materials | 2 |
| 2 - Measured Test Parameters | 4 |
| 3 - Weight Loss Results of C70600 Exposures | 5 |
| 4 - Weight Loss Results of C71500 Exposures | 5 |
| 5 - Weight Loss Results of C72200 Exposures | 6 |
| 6 - Weight Loss Results of C68700 Exposures | 6 |
| 7 - Best Fit Regression Analysis Equations | 8 |
| 8 - Depth of Attack Results for C70600 | 10 |

TABLE OF CONTENTS (Cont)

| | Page |
|---|------|
| 9 - Depth of Attack Results for C71500 | 11 |
| 10 - Depth of Attack Results for C72200 | 11 |
| 11 - Depth of Attack Results for C68700 | 12 |

LIST OF ABBREVIATIONS

| | |
|--------------------|---------------------------------|
| cm | Centimeter |
| °C | Degree Celsius |
| hr | Hour |
| mg | Milligram |
| mg/cm ² | Milligram per centimeter square |
| mg/l | Milligram per liter |
| mm | Millimeter |
| m/s | Meter per second |
| μm | Micrometer |
| mm/yr | Millimeter per year |
| WQ | Water quench |

ABSTRACT

The combined influence of low-level sulfide pollution in seawater and water velocity on several copper base condenser alloys was investigated. The alloys studied included 90-10 copper-nickel (C70600), 70-30 copper-nickel (C71500), IN838 (C72200), and aluminum-brass (C68700). Thin specimens of these alloys were exposed in a nonrecirculating test loop to aerated natural seawater containing additions of sodium sulfide. Sulfide concentrations were 0.0, 0.01, 0.05, and 0.10 milligram per liter and dissolved oxygen levels were nominally 80% of air-saturated values. The effect of change in flow velocity in the range of 0.5 to 4.0 meters per second on sulfide-induced accelerated corrosion was studied over test durations of 30-90 days. The amount of sulfide-induced corrosion on C70600 and C71500 was found to depend primarily on the interaction between sulfide concentration and velocity, with the effect of either variable being minimum when the other was low. The variation of sulfide induced corrosion of C72200 and C68700 with sulfide concentration and velocity was found to be much more complex, possibly due to the chromium, aluminum or zinc additions.

ADMINISTRATIVE INFORMATION

This project was partly funded under the Submarine Materials Technology Block Program (PE62761N, SF61541-591) sponsored by the Naval Sea Systems Command (SEA 05R15, Dr. H. H. Vanderveldt). This report meets in part milestone number 2803-149-45 of the program. The authors also acknowledge the financial support of INCO, Ltd.

INTRODUCTION

The adverse effect of H_2S in aerated seawater on the corrosion resistance of copper alloys is well known.^{1-6*} In some cases the H_2S is generated by the action of sulfate-reducing bacteria under anaerobic conditions such as in harbor bottom mud or during stagnant shutdown of cooling systems⁴ and subsequently introduced into aerated seawater. Several studies have been conducted to define the limits of susceptibility of copper-nickel condenser tubing materials to sulfide ion contamination.^{3,5,7-11} These studies have generally varied sulfide ion concentration and/or exposure time. The proposed mechanism for this attack involves mechanical as well as electrochemical processes.⁵ Therefore, an important variable should be seawater

*A complete list of references appears on page 21.

turbulence as related to flow velocity. Exposure velocity has previously been studied to a limited extent involving only short-duration sulfide exposure.¹¹ The objective of this investigation was to quantify the effects of the major sulfide exposure variables - concentration, duration, and velocity - on the corrosion behavior of four copper-base condenser tube alloys. For this purpose, exposures were conducted for 30, 60, and 90 days in aerated seawater, at sulfide concentrations of 0.0, 0.01, 0.05, 0.10 mg/l* and flow velocities of 0.5, 1.0, 2.0, and 4.0 meters per second.

EXPERIMENTAL PROCEDURE

MATERIALS

The alloys investigated in this study were 90-10 copper-nickel (C70600), 70-30 copper-nickel (C71500), 85-15 copper-nickel plus chromium (C72200), and aluminum brass (C68700). Composition and processing condition of the test materials are presented in Table 1. Each alloy was obtained in the proper thickness and machined to the final length and width for test.

TABLE 1 - COMPOSITION AND PROCESSING OF TEST MATERIALS

| Alloy | Composition Wt % | Processing |
|------------------------------|---|--|
| 90/10 Cu-Ni (C70600) | 0.01 Pb 1.12 Fe 0.096 Zn <0.02 P 9.7 Ni 0.25 Mn <0.02 S | Mill annealed, rolled sheet (most Fe in solution) |
| 70/30 Cu-Ni (C71500) | 29.7 Ni 0.52 Fe 0.4 Mn 0.002 Pb 0.001 P 0.007 S 0.06 Zn | Mill annealed, rolled sheet |
| 85-15 Cu-Ni + Cr (C72200) | 0.001 C 0.80 Mn 15.9 Ni 0.63 Cr 0.002 S 0.83 Fe 0.009 P | 815C/1 hr/WQ |
| Al-Brass (C68700) | 17.8 Zn 0.0021 Pb 0.02 Fe 2.16 Al 0.092 As | Mill annealed, rolled sheet |

*Definitions of abbreviations appear on page v.

APPARATUS

All exposures in sulfide-modified seawater were conducted in the modified seawater test apparatus illustrated in Figure 1. Exposures of control specimens in normal seawater were carried out in the seawater test apparatus shown in Figure 2. Both apparatus, located at the LaQue Center for Corrosion Technology at Wrightsville Beach, North Carolina, were constructed of PVC pipe with removable test sections containing specimen holders and taps for sampling water near each removable section. The modified seawater apparatus was fitted with a series of injection pumps for adding controlled amounts of sodium sulfide to the incoming seawater and chlorine generator units at the discharge to oxidize any remaining sulfide. Each removable pipe section housed three cylindrical Delrin specimen holders. Each holder supported eight specimens (1.8 x 16.5 x 0.2 cm) parallel to each other and to the water flow. The specimen edges were untapered such that turbulence would be generated at the leading edges.

Duplicate specimens of each material were exposed for 30, 60, and 90 days at each sulfide concentration and seawater velocity. Prior to exposure, specimens were degreased, cleaned in 10% H_2SO_4 , pumice scrubbed, and acetone degreased. Weight loss determinations were made to the nearest 0.1 mg, and a maximum depth of attack on the boldly exposed surfaces of each specimen was recorded using a point-to-point micrometer (± 0.01 millimeter).

Seawater velocities of 0.5, 1.0, 2.0, and 4.0 m/s were maintained through the test sections by the use of weir boxes. Nominal sulfide concentrations of 0.01, 0.05, and 0.1 mg/l were achieved via continuous, metered additions of aqueous sodium sulfide. No detectable pH change was noted during sulfide injection. The conditions existing in the test loops represented nonequilibrium, i.e. coexistence of sulfide and oxygen, since measurements in the loop indicated that insufficient time was allowed for the sulfide to react with the excess oxygen present.

The sulfide and ferrous ion levels were measured daily using the p-phenylenediamine colorimetric technique¹² (with a turbidity correction) and the 1, 10-phenanthroline method,¹³ respectively. Seawater temperature and flow were monitored nine times daily during the exposures.

The background levels of sulfide and ferrous ions were measured at less than 0.001 mg/l and the dissolved oxygen content was nominally 80% of the air saturated value for the given seawater temperature. Ferrous ion levels are important since they are a powerful corrosion inhibitor for copper alloys. The background level of

0.001 mg/l is too small for any inhibition effects however. The measured values for sulfide ion concentration and temperature are summarized in Table 2. The standard deviations of the sulfide levels are generally high compared to the means, indicating the difficulty in controlling injection at these low levels.

TABLE 2 - MEASURED TEST PARAMETERS

| Desired Control Level Sulfide mg/l | Actual Levels | | | | | |
|---------------------------------------|------------------|--------------------|------------------|--------------------|------------------|--------------------|
| | 30-Day Exposures | | 60-Day Exposures | | 90-Day Exposures | |
| | Mean | Standard Deviation | Mean | Standard Deviation | Mean | Standard Deviation |
| <0.001 | 0.000 | 0.000 | 0.000 | 0.000 | 0.000 | 0.000 |
| 0.01 | 0.010 | 0.005 | 0.010 | 0.005 | 0.009 | 0.006 |
| 0.05 | 0.040 | 0.019 | 0.047 | 0.021 | 0.045 | 0.020 |
| 0.10 | 0.093 | 0.027 | 0.092 | 0.027 | 0.089 | 0.026 |
| Temperature °C | | | | | | |
| None | 10.8 | 1.95 | 9.33 | 2.38 | 9.58 | 2.54 |

RESULTS AND DISCUSSION

This study generated a considerable amount of data, and, therefore, it was decided to employ statistical analysis to identify the relevant information. Regression analysis¹⁴ was used to examine the functional relationship between the general corrosion of the alloys (weight loss per unit area) and the sulfide level, seawater velocity, and exposure duration.

Regression analysis assumes the existence of a functional relationship between two or more variables. In most physical systems, the functional relationships are complex. Using regression analysis, one may choose to approximate the true functional relationship with some relatively simple mathematical function which contains the appropriate variables. This technique was used (1) to attain a better understanding of the corrosion processes involved on a phenomenological basis and (2) to develop its use as a predictive tool.

The weight loss exposure results for the four alloys are shown in Tables 3-6. These data were used for the regression analyses with weight loss per unit area as the measured dependent response variable and with sulfide level and seawater velocity as the independent variables of interest. Data for the three test durations - 30, 60, and 90 days - were included. All statistical analyses were performed utilizing a Tektronix 4051 computer and accompanying multiple linear regression analysis software.

TABLE 3 - WEIGHT LOSS RESULTS
OF C70600 EXPOSURES

| Sulfide (mg/l) | Velocity (m/s) | Weight Loss (mg/cm ²) | | |
|-------------------|-------------------|-----------------------------------|---------|---------|
| | | 30 Days | 60 Days | 90 Days |
| ≤0.001 | 0.5 | 6.5 | 12.1 | 12.2 |
| ≤0.001 | 0.5 | 6.4 | 12.3 | 13.9 |
| ≤0.001 | 1.0 | 7.2 | 12.2 | 20.1 |
| ≤0.001 | 1.0 | 6.9 | 12.9 | 18.4 |
| ≤0.001 | 2.0 | 8.0 | 15.2 | 21.9 |
| ≤0.001 | 2.0 | 8.1 | 14.5 | 21.5 |
| ≤0.001 | 4.0 | 9.0 | 17.0 | 24.3 |
| ≤0.001 | 4.0 | 9.0 | 17.2 | 25.0 |
| 0.01 | 0.5 | 12.1 | 14.2 | 13.7 |
| 0.01 | 0.5 | 13.0 | 14.4 | 14.5 |
| 0.01 | 1.0 | 16.2 | 23.2 | 23.3 |
| 0.01 | 1.0 | 16.2 | 22.8 | 25.6 |
| 0.01 | 2.0 | 20.1 | 28.1 | 31.7 |
| 0.01 | 2.0 | 21.0 | 24.8 | 26.7 |
| 0.01 | 4.0 | 24.0 | 36.0 | 48.1 |
| 0.01 | 4.0 | 25.7 | 34.6 | 47.7 |
| 0.05 | 0.5 | 12.5 | 12.9 | 15.3 |
| 0.05 | 0.5 | 12.8 | 14.3 | 16.7 |
| 0.05 | 1.0 | 13.7 | 13.2 | 16.5 |
| 0.05 | 1.0 | 14.5 | 14.9 | 15.6 |
| 0.05 | 2.0 | 18.9 | 22.9 | 37.1 |
| 0.05 | 2.0 | 20.3 | 26.0 | 40.6 |
| 0.05 | 4.0 | 35.9 | 76.0 | 99.5 |
| 0.05 | 4.0 | 45.3 | 75.9 | 132.1 |
| 0.10 | 0.5 | 10.8 | 19.0 | 14.6 |
| 0.10 | 0.5 | 11.2 | 13.2 | 13.1 |
| 0.10 | 1.0 | 14.7 | 21.0 | 17.4 |
| 0.10 | 1.0 | 13.3 | 25.8 | 19.0 |
| 0.10 | 2.0 | 28.6 | 48.6 | 68.3 |
| 0.10 | 2.0 | 28.1 | 75.3 | - |
| 0.10 | 4.0 | 30.6 | 62.7 | 84.8 |
| 0.10 | 4.0 | 29.0 | 65.5 | 106.6 |

TABLE 4 - WEIGHT LOSS RESULTS
OF C71500 EXPOSURES

| Sulfide (mg/l) | Velocity (m/s) | Weight Loss (mg/cm ²) | | |
|-------------------|-------------------|-----------------------------------|---------|---------|
| | | 30 days | 60 days | 90 days |
| ≤0.001 | 0.5 | 8.6 | 11.3 | 12.4 |
| ≤0.001 | 0.5 | 9.1 | 10.5 | 12.0 |
| ≤0.001 | 1.0 | 14.6 | 18.2 | 22.5 |
| ≤0.001 | 1.0 | 14.9 | 18.7 | 23.4 |
| ≤0.001 | 2.0 | 15.1 | 24.5 | 32.5 |
| ≤0.001 | 2.0 | 14.5 | 25.7 | 28.6 |
| ≤0.001 | 4.0 | 16.4 | 30.1 | 43.5 |
| ≤0.001 | 4.0 | 16.5 | 29.9 | 42.8 |
| 0.01 | 0.5 | 4.4 | 8.0 | 11.7 |
| 0.01 | 0.5 | 4.4 | 6.3 | 12.6 |
| 0.01 | 1.0 | 8.8 | 8.0 | 14.6 |
| 0.01 | 1.0 | 7.7 | 12.6 | 12.8 |
| 0.01 | 2.0 | 17.6 | 22.5 | 27.9 |
| 0.01 | 2.0 | 15.9 | 22.3 | 27.9 |
| 0.01 | 4.0 | 19.4 | 29.6 | 71.0 |
| 0.01 | 4.0 | 19.6 | 41.8 | 70.2 |
| 0.05 | 0.5 | 14.7 | 31.8 | 28.9 |
| 0.05 | 0.5 | 12.8 | 19.0 | 39.2 |
| 0.05 | 1.0 | 16.4 | 26.2 | 38.5 |
| 0.05 | 1.0 | 13.0 | 18.1 | 31.9 |
| 0.05 | 2.0 | 16.1 | 57.2 | 66.2 |
| 0.05 | 2.0 | 18.3 | 44.3 | 80.4 |
| 0.05 | 4.0 | 34.7 | 79.4 | 177.8 |
| 0.05 | 4.0 | 33.0 | 92.5 | 151.5 |
| 0.10 | 0.5 | 10.1 | 20.4 | 35.2 |
| 0.10 | 0.5 | 8.5 | 14.9 | 26.8 |
| 0.10 | 1.0 | 20.1 | 46.1 | 70.4 |
| 0.10 | 1.0 | 18.8 | 44.1 | 61.8 |
| 0.10 | 2.0 | 40.2 | 104.6 | 158.5 |
| 0.10 | 2.0 | 36.9 | 94.0 | 190.0 |
| 0.10 | 4.0 | 60.7 | 156.4 | 269.5 |
| 0.10 | 4.0 | 57.6 | 151.6 | 227.7 |

TABLE 5 - WEIGHT LOSS RESULTS
OF C7200 EXPOSURES

| Sulfide (mg/l) | Velocity (m/s) | Weight Loss (mg/cm ²) | | |
|-------------------|-------------------|-----------------------------------|---------|---------|
| | | 30 days | 60 days | 90 days |
| ≤0.001 | 0.5 | 3.4 | 3.5 | 3.7 |
| ≤0.001 | 0.5 | 4.0 | 3.9 | 3.9 |
| ≤0.001 | 1.0 | 3.4 | 4.9 | 3.8 |
| ≤0.001 | 1.0 | 2.8 | 3.1 | 4.0 |
| ≤0.001 | 2.0 | 5.9 | 3.6 | 4.5 |
| ≤0.001 | 2.0 | 3.3 | 4.3 | 3.6 |
| ≤0.001 | 4.0 | 3.9 | 4.6 | 3.4 |
| ≤0.001 | 4.0 | 3.6 | 3.8 | 4.0 |
| 0.01 | 0.5 | 3.3 | 5.2 | 8.3 |
| 0.01 | 0.5 | 3.6 | 7.6 | 7.9 |
| 0.01 | 1.0 | 5.9 | 10.7 | 13.6 |
| 0.01 | 1.0 | 6.8 | 9.4 | 19.1 |
| 0.01 | 2.0 | 17.0 | 27.3 | 30.7 |
| 0.01 | 2.0 | 10.3 | 35.2 | 37.9 |
| 0.01 | 4.0 | 22.6 | 49.4 | 77.4 |
| 0.01 | 4.0 | 31.8 | 42.0 | 85.4 |
| 0.05 | 0.5 | 14.4 | 26.9 | 46.4 |
| 0.05 | 0.5 | 12.5 | 27.2 | 54.6 |
| 0.05 | 1.0 | 15.6 | 39.6 | 38.9 |
| 0.05 | 1.0 | 15.0 | 30.6 | 36.5 |
| 0.05 | 2.0 | 37.8 | 47.6 | 74.3 |
| 0.05 | 2.0 | 24.2 | 43.8 | 101.6 |
| 0.05 | 4.0 | 45.9 | 72.1 | 92.9 |
| 0.05 | 4.0 | 40.8 | 75.6 | 99.8 |
| 0.10 | 0.5 | 22.3 | 43.8 | 59.1 |
| 0.10 | 0.5 | 19.5 | 33.2 | 62.2 |
| 0.10 | 1.0 | 28.7 | 56.3 | 112.1 |
| 0.10 | 1.0 | 30.4 | 68.5 | 121.9 |
| 0.10 | 2.0 | 40.1 | 64.0 | 166.7 |
| 0.10 | 2.0 | 53.7 | 72.8 | 117.6 |
| 0.10 | 4.0 | 47.9 | 85.2 | 78.0 |
| 0.10 | 4.0 | 45.7 | 48.6 | 104.8 |

TABLE 6 - WEIGHT LOSS RESULTS
OF C68700 EXPOSURES

| Sulfide (mg/l) | Velocity (m/s) | Weight Loss (mg/cm ²) | | |
|-------------------|-------------------|-----------------------------------|---------|---------|
| | | 30 days | 60 days | 90 days |
| ≤0.001 | 0.5 | 5.9 | 6.8 | 7.7 |
| ≤0.001 | 0.5 | 5.9 | 6.8 | 6.8 |
| ≤0.001 | 1.0 | 5.8 | 8.9 | 13.4 |
| ≤0.001 | 1.0 | 5.8 | 8.4 | 14.4 |
| ≤0.001 | 2.0 | 6.6 | 16.3 | 19.2 |
| ≤0.001 | 2.0 | 6.5 | 16.2 | 18.3 |
| ≤0.001 | 4.0 | 7.3 | 14.7 | 25.4 |
| ≤0.001 | 4.0 | 7.4 | 14.1 | 25.2 |
| 0.01 | 0.5 | 8.2 | - | 13.2 |
| 0.01 | 0.5 | 8.0 | - | 13.6 |
| 0.01 | 1.0 | 11.6 | 55.0 | 25.1 |
| 0.01 | 1.0 | 11.2 | 55.5 | 26.1 |
| 0.01 | 2.0 | 16.0 | 48.9 | 51.9 |
| 0.01 | 2.0 | 16.0 | 53.1 | 60.8 |
| 0.01 | 4.0 | 20.5 | 64.3 | 71.1 |
| 0.01 | 4.0 | 21.5 | 65.0 | 73.1 |
| 0.05 | 0.5 | 10.2 | 13.3 | 35.6 |
| 0.05 | 0.5 | 9.7 | 14.9 | 31.9 |
| 0.05 | 1.0 | 10.1 | 15.2 | 40.0 |
| 0.05 | 1.0 | 9.6 | 15.9 | 35.7 |
| 0.05 | 2.0 | 13.8 | 23.4 | 51.8 |
| 0.05 | 2.0 | 13.2 | 20.4 | 42.2 |
| 0.05 | 4.0 | 41.5 | 64.8 | 114.4 |
| 0.05 | 4.0 | 33.2 | 60.0 | 81.7 |
| 0.10 | 0.5 | 9.4 | 17.1 | 53.2 |
| 0.10 | 0.5 | 8.8 | 17.5 | 54.4 |
| 0.10 | 1.0 | 11.9 | 51.8 | 69.7 |
| 0.10 | 1.0 | 10.2 | 33.7 | 67.2 |
| 0.10 | 2.0 | 30.1 | 91.8 | 98.1 |
| 0.10 | 2.0 | 28.0 | 73.6 | 89.2 |
| 0.10 | 4.0 | 46.1 | 93.0 | 79.4 |
| 0.10 | 4.0 | 48.4 | 97.0 | 84.0 |

The computer analysis technique involves the entry of various candidate mathematical functions of the independent variables. A selection of the most significant variables with the appropriate computed numerical coefficients forms the "regression equation". This equation takes the form:

$$\emptyset = C_0 + C_1 f_1(S,V) \dots + C_n f_n(S,V)$$

where

$$\emptyset \text{ is the corrosion weight loss in mg/cm}^2 \quad (1)$$

$$S \text{ is sulfide level in mg/l} \quad (2)$$

$$V \text{ is seawater velocity in m/s} \quad (3)$$

$$f_n \text{ is some function of } S \text{ and/or } V \quad (4)$$

$$C_n \text{ is the regression coefficient.} \quad (5)$$

For this study, the candidate functions S , V , S^2 , V^2 , $\ln(S)$, $\ln(V)$, e^S , and e^V were entered to include both simple and higher order dependence of \emptyset upon S or V . The terms SV , S^2V , and SV^2 were also entered to provide for possible interactions, or synergistic effects between S and V .

The regression analysis results are given in Table 7. The best fit equations are given for each alloy and test duration. To provide an indication of the "goodness of fit", the statistical parameter - correlation coefficient - is given as R . Perfect fit of the data to the regression equation is indicated by $R=1.0$. Conversely, a complete lack of fit is indicated by $R=0$. The form of the equations is more important than the values of the coefficients in suggesting important relationships between the experimental variables.

The C70600 regression equations show a good fit for all three test durations ($R>0.89$) when only the two terms, SV and S^2V , are included. The multiplicative interaction of the sulfide level and velocity is thus more important to the corrosion process than the variables taken individually. This suggests that, to characterize the corrosion resistance of this alloy for various sulfide levels and velocities, one may not simply determine the effects of sulfide or velocity and combine these effects additively. Stated phenomenologically, the effects of velocity are more pronounced at increasing sulfide levels and, similarly, the effects of sulfide level are more pronounced at increasing velocities. This supports the corrosion mechanism based on corrosion product film modification combined with the mechanical action of turbulence.⁵ The similar form of the regression equations for the three test durations suggest that the variation of corrosion with time - i.e. the corrosion reaction

kinetics - is obeying a fairly uniform, continuous rate function over the 90-day period. This linear weight loss, as a function of time, is quite different from kinetics of reactions in clean seawater, where the rate typically decreases with increasing exposure duration.

TABLE 7 - BEST FIT REGRESSION
ANALYSIS EQUATIONS

| | |
|---------------|---|
| <u>C70600</u> | |
| 30 days: | $\phi = 9.8 + (251 S \times V) - (1950 S^2 \times V)$ R = 0.904 |
| 60 days: | $\phi = 12.7 + (411 S \times V) - (2630 S^2 \times V)$ R = 0.893 |
| 90 days: | $\phi = 11.2 + (734 S \times V) - (5220 S^2 \times V)$ R = 0.928 |
| <u>C71500</u> | |
| 30 days: | $\phi = 10.4 + (121 S \times V)$ R = 0.955 |
| 60 days: | $\phi = 14.9 + (356 S \times V)$ R = 0.974 |
| 90 days: | $\phi = 19.6 + (618 S \times V)$ R = 0.963 |
| <u>C72200</u> | |
| 30 days: | $\phi = 6.5 + (285 S \times V) - (41.2 S \times V^2)$ R = 0.925 |
| 60 days: | $\phi = 77.4 + (11.7 \ln S) + (13.8 \ln V)$ R = 0.914 |
| 90 days: | $\phi = 70.7 + (490 S) + (10.6 \ln S) + (19.6 \ln V)$ R = 0.889 |
| <u>C68700</u> | |
| 30 days: | $\phi = 9.8 + (27 S \times V^2)$ R = 0.931 |
| 60 days: | $\phi = 41.7 + (110 S^2 \times V) + (4.19 \ln S) + (16.3 \ln V)$ R = 0.828 |
| 90 days: | $\phi = 83.7 + (22.7 S \times V) + (10.8 \ln S) + (19.3 \ln V)$ R = 0.907 |

The C71500 regression equations show the best correlation ($R > 0.95$) of the four alloys. These equations also involve an interaction between sulfide level and velocity as in the case of C70600, but are simpler since they include only one multiplicative term of sulfide level and velocity. Again, the form of the equation is very similar for the three test durations, implying uniform, continuous corrosion reaction kinetics.

C72200 and C68700 required a larger number of more complex terms in the regression equations to obtain a reasonably high degree of correlation with the data. Only S-V interaction terms are involved at 30 days exposure. However, the form of the regression equations is not consistent for longer exposure times. This implies that a complex function of sulfide and velocity is involved in the corrosion reaction kinetics. The obvious compositional differences between these alloys and C70600 and C71500 may explain the somewhat poorer correlations, the more complex mathematics in the regression equations, and the resultant implication of more complex corrosion kinetics. The chromium and aluminum or zinc additions in C72200 and C68700, respectively, probably result in a more complex corrosion mechanism when contrasted with the simple Cu-Ni alloys, probably due to modification of the corrosion product film.

The application of these regression equations is illustrated in Figures 3-6. In these figures, the cross plots using the 90-day regression equations are presented for each alloy and the results converted to corrosion rates. These figures must not be used for predicting corrosion rates of these materials in service, since the flow geometry differences could affect the results, and since the estimation errors are not considered in the plots. Trends should be similar, however. For C70600 and C71500 (Figures 3 and 4) the interaction terms make the iso-corrosion rate lines asymptotic to the axes. In Figure 3, the additional sulfide-squared interaction term causes the rise in these lines at higher sulfide levels. The behavior of C72200 (Figure 5) is similar, but the lines converge at high sulfide levels, indicating a larger effect of velocity on the corrosion reaction at high sulfide levels. C68700 (in Figure 6) behaves like C70600 and C71500, although the effect on corrosion rate of velocity at low sulfide levels is much greater for this alloy.

The maximum depth of attack data for each specimen is presented in Tables 8-11. One is tempted to compare exposure conditions by averaging the depth of attack data and looking at the differences between the averages. However, the variability between the two data points at each exposure condition must also be considered in

making the assessment. The mean square of the within-sample error is shown in each table. The calculation of this number involves averaging the values of the two depths of attack in each exposure condition and subtracting this average from each value. These differences are squared and summed. The square root of the sum is then divided by the total number of test conditions. The result is an estimate of the variation of the depth of attack value under similar exposure conditions. A large value compared to the differences in the averages for different exposure conditions means that the scatter will mask any changes in behavior due to varying exposure conditions. Without doing a full analysis of variance, it can still be seen that in many cases the mean square of the error is about equal to, or larger than, the changes in the average depth of attack as a function of test condition. Therefore, the variability in the data was too high in many cases to get meaningful results from a regression analysis. Thus, regression analysis was not used on the depth of attack data.

TABLE 8 - DEPTH OF ATTACK RESULTS
FOR C70600

| Sulfide (mg/l) | Velocity (m/s) | Maximum Depth of Attack (μm) | | |
|-------------------|-------------------|---|---------|---------|
| | | 30 days | 60 days | 90 days |
| ≤ 0.001 | 0.5 | 20 | 60 | 70 |
| ≤ 0.001 | 0.5 | 30 | 40 | 60 |
| ≤ 0.001 | 1.0 | 30 | 50 | 70 |
| ≤ 0.001 | 1.0 | 50 | 50 | 80 |
| ≤ 0.001 | 2.0 | 50 | 90 | 110 |
| ≤ 0.001 | 2.0 | 50 | 80 | 120 |
| ≤ 0.001 | 4.0 | 40 | 70 | 130 |
| ≤ 0.001 | 4.0 | 40 | 70 | 110 |
| 0.01 | 0.5 | 60 | 70 | 50 |
| 0.01 | 0.5 | 60 | 60 | 90 |
| 0.01 | 1.0 | 50 | 60 | 80 |
| 0.01 | 1.0 | 60 | 90 | 100 |
| 0.01 | 2.0 | 140 | 530 | 160 |
| 0.01 | 2.0 | 70 | 360 | 280 |
| 0.01 | 4.0 | 180 | 300 | 390 |
| 0.01 | 4.0 | 150 | 410 | 420 |
| 0.05 | 0.5 | 50 | 30 | 50 |
| 0.05 | 0.5 | 50 | 30 | 60 |
| 0.05 | 1.0 | 40 | 30 | 50 |
| 0.05 | 1.0 | 50 | 50 | 40 |
| 0.05 | 2.0 | 50 | 140 | 160 |
| 0.05 | 2.0 | 70 | 120 | 210 |
| 0.05 | 4.0 | 340 | >2000 | 1160 |
| 0.05 | 4.0 | 620 | >2000 | 1250 |
| 0.10 | 0.5 | 30 | 50 | 10 |
| 0.10 | 0.5 | 40 | 50 | 40 |
| 0.10 | 1.0 | 70 | 70 | 40 |
| 0.10 | 1.0 | 40 | 90 | 50 |
| 0.10 | 2.0 | 210 | 900 | - |
| 0.10 | 2.0 | 100 | 750 | 750 |
| 0.10 | 4.0 | 230 | 580 | 1000 |
| 0.10 | 4.0 | 170 | 800 | >2000 |

Mean square of within-sample error = 16.4

TABLE 9 - DEPTH OF ATTACK RESULTS
FOR C71500

| Sulfide (mg/l) | Velocity (m/s) | Maximum Depth of Attack (µm) | | |
|-------------------|-------------------|------------------------------|---------|---------|
| | | 30 days | 60 days | 90 days |
| ≤0.001 | 0.5 | 60 | 80 | 100 |
| ≤0.001 | 0.5 | 90 | 90 | 90 |
| ≤0.001 | 1.0 | 70 | 100 | 120 |
| ≤0.001 | 1.0 | 110 | 70 | 120 |
| ≤0.001 | 2.0 | 120 | 130 | 180 |
| ≤0.001 | 2.0 | 130 | 140 | 140 |
| ≤0.001 | 4.0 | 130 | 210 | 320 |
| ≤0.001 | 4.0 | 150 | 210 | 280 |
| 0.01 | 0.5 | 80 | 80 | 30 |
| 0.01 | 0.5 | 50 | 50 | 70 |
| 0.01 | 1.0 | 30 | 20 | 30 |
| 0.01 | 1.0 | 30 | 40 | 80 |
| 0.01 | 2.0 | 50 | 60 | 70 |
| 0.01 | 2.0 | 100 | 20 | 80 |
| 0.01 | 4.0 | 80 | 440 | 670 |
| 0.01 | 4.0 | 50 | 310 | 250 |
| 0.05 | 0.5 | 70 | 260 | 50 |
| 0.05 | 0.5 | 130 | 110 | 180 |
| 0.05 | 1.0 | 230 | 120 | 330 |
| 0.05 | 1.0 | 30 | 120 | 200 |
| 0.05 | 2.0 | 50 | 1300 | 520 |
| 0.05 | 2.0 | 20 | 1310 | 700 |
| 0.05 | 4.0 | 290 | 520 | 1190 |
| 0.05 | 4.0 | 360 | 960 | 1200 |
| 0.10 | 0.5 | 200 | 40 | 70 |
| 0.10 | 0.5 | 20 | 20 | 20 |
| 0.10 | 1.0 | 180 | 250 | 340 |
| 0.10 | 1.0 | 50 | 200 | 260 |
| 0.10 | 2.0 | 110 | 430 | 970 |
| 0.10 | 2.0 | 150 | 640 | 600 |
| 0.10 | 4.0 | 270 | 990 | 1070 |
| 0.10 | 4.0 | 490 | 1170 | 1110 |

Mean square of within-sample error = 14.3

TABLE 10 - DEPTH OF ATTACK RESULTS
FOR C72200

| Sulfide (mg/l) | Velocity (m/s) | Maximum Depth of Attack (µm) | | |
|-------------------|-------------------|------------------------------|---------|---------|
| | | 30 days | 60 days | 90 days |
| ≤0.001 | 0.5 | 70 | 50 | 50 |
| ≤0.001 | 0.5 | 50 | 30 | 20 |
| ≤0.001 | 1.0 | 110 | 20 | 30 |
| ≤0.001 | 1.0 | 20 | 50 | 50 |
| ≤0.001 | 2.0 | 100 | 30 | 30 |
| ≤0.001 | 2.0 | 50 | 100 | 50 |
| ≤0.001 | 4.0 | 20 | 30 | 110 |
| ≤0.001 | 4.0 | 60 | 100 | 130 |
| 0.01 | 0.5 | 60 | 110 | 50 |
| 0.01 | 0.5 | 150 | 90 | 20 |
| 0.01 | 1.0 | 120 | 240 | 90 |
| 0.01 | 1.0 | 50 | 160 | 90 |
| 0.01 | 2.0 | 80 | 300 | 360 |
| 0.01 | 2.0 | 130 | 340 | 230 |
| 0.01 | 4.0 | 130 | 220 | 260 |
| 0.01 | 4.0 | 200 | 230 | 600 |
| 0.05 | 0.5 | 120 | 130 | 150 |
| 0.05 | 0.5 | 60 | 150 | 260 |
| 0.05 | 1.0 | 230 | 280 | 550 |
| 0.05 | 1.0 | 80 | 330 | 480 |
| 0.05 | 2.0 | 520 | 290 | 590 |
| 0.05 | 2.0 | 230 | 400 | 660 |
| 0.05 | 4.0 | 460 | 660 | 520 |
| 0.05 | 4.0 | 330 | 500 | 570 |
| 0.10 | 0.5 | 450 | 650 | 410 |
| 0.10 | 0.5 | 410 | 310 | 550 |
| 0.10 | 1.0 | 240 | 670 | 480 |
| 0.10 | 1.0 | 120 | 550 | 680 |
| 0.10 | 2.0 | 430 | 530 | 600 |
| 0.10 | 2.0 | 620 | 530 | 680 |
| 0.10 | 4.0 | 620 | 560 | 370 |
| 0.10 | 4.0 | 410 | 460 | 540 |

Mean square of the within-sample error = 15.0

TABLE 11 - DEPTH OF ATTACK RESULTS
FOR C68700

| Sulfide (mg/l) | Velocity (m/s) | Maximum Depth of Attack (μ m) | | |
|-------------------|-------------------|------------------------------------|---------|---------|
| | | 30 days | 60 days | 90 days |
| ≤0.001 | 0.5 | 30 | 20 | 20 |
| ≤0.001 | 0. | 20 | 40 | 30 |
| ≤0.001 | 1.0 | 30 | 30 | 70 |
| ≤0.001 | 1.0 | 30 | 40 | 130 |
| ≤0.001 | 2.0 | 20 | 100 | 170 |
| ≤0.001 | 2.0 | 30 | 100 | 130 |
| ≤0.001 | 4.0 | 20 | 80 | 140 |
| ≤0.001 | 4.0 | 20 | 70 | 130 |
| 0.01 | 0.5 | 40 | 450 | 60 |
| 0.01 | 0.5 | 40 | 500 | 70 |
| 0.01 | 1.0 | 60 | 210 | 90 |
| 0.01 | 1.0 | 40 | 210 | 130 |
| 0.01 | 2.0 | 80 | 620 | 660 |
| 0.01 | 2.0 | 210 | 890 | 530 |
| 0.01 | 4.0 | 610 | 600 | 590 |
| 0.01 | 4.0 | 200 | 850 | 620 |
| 0.05 | 0.5 | 40 | 100 | 90 |
| 0.05 | 0.5 | 50 | 80 | 100 |
| 0.05 | 1.0 | 60 | 90 | 150 |
| 0.05 | 1.0 | 40 | 80 | 130 |
| 0.05 | 2.0 | 80 | 450 | 540 |
| 0.05 | 2.0 | 60 | 100 | 400 |
| 0.05 | 4.0 | 450 | 700 | 640 |
| 0.05 | 4.0 | 490 | 620 | 910 |
| 0.10 | 0.5 | 40 | 60 | 230 |
| 0.10 | 0.5 | 30 | 80 | 150 |
| 0.10 | 1.0 | 60 | 200 | 200 |
| 0.10 | 1.0 | 50 | 110 | 220 |
| 0.10 | 2.0 | 190 | 1060 | 720 |
| 0.10 | 2.0 | 330 | 530 | >2000 |
| 0.10 | 4.0 | 500 | 1050 | 650 |
| 0.10 | 4.0 | 510 | 1010 | 690 |

Mean square of within-sample error = 23.4

Some trends can be observed, however. In Table 8, little effect of velocity at <0.001 mg/l sulfide or of sulfide at 0.5 m/s velocity can be observed on the depth of attack of C70600 above the background error. At high velocity, the effect of increasing sulfide is considerable and at high sulfide levels, the effect of increasing velocity is considerable. These observations support the weight loss analysis, in that the only significant effects on corrosion of C70600 are the S-V interactions.

C71500 exhibits only a slight increase in depth of attack with increasing velocity at >0.001 mg/l sulfide, and no increase with increasing sulfide levels at 0.5 m/s velocity (Table 9). As with C70600, when either variable is high, the effect on depth of attack of increasing the other is considerable. This is most evident in the 90-day data. Once again, this supports the weight loss analysis, with the most significant influence being the S-V interaction.

C72200 and C68700 (Tables 10 and 11, respectively) show more complex behavior, with depth of attack values for specific exposures having some sulfide dependence at low velocity and/or some velocity dependence at low sulfide concentration. This information also supports the conclusion from the weight loss data regarding the complexity of the corrosion behavior of these materials.

CONCLUSIONS

The corrosion of C70600 and C71500 in aerated sulfide-containing seawater is primarily a function of the synergistic effect between sulfide concentration and seawater velocity. The effect of either of these variables on corrosion is very small if the other variable is low, and increases as the other variable increases. The kinetics of the corrosion process appear to be fairly simple, and the rate does not decrease with time as in seawater without sulfide.

At 30-day exposure times, the corrosion of C72200 and C68700 are also primarily a function of a sulfide/velocity interaction. The behavior of these alloys in sulfide-containing seawater becomes much more complex as exposure duration increases. This is probably due to the involvement in the corrosion process of the chromium, aluminum, or zinc elements in these alloys which can affect corrosion product film structure.

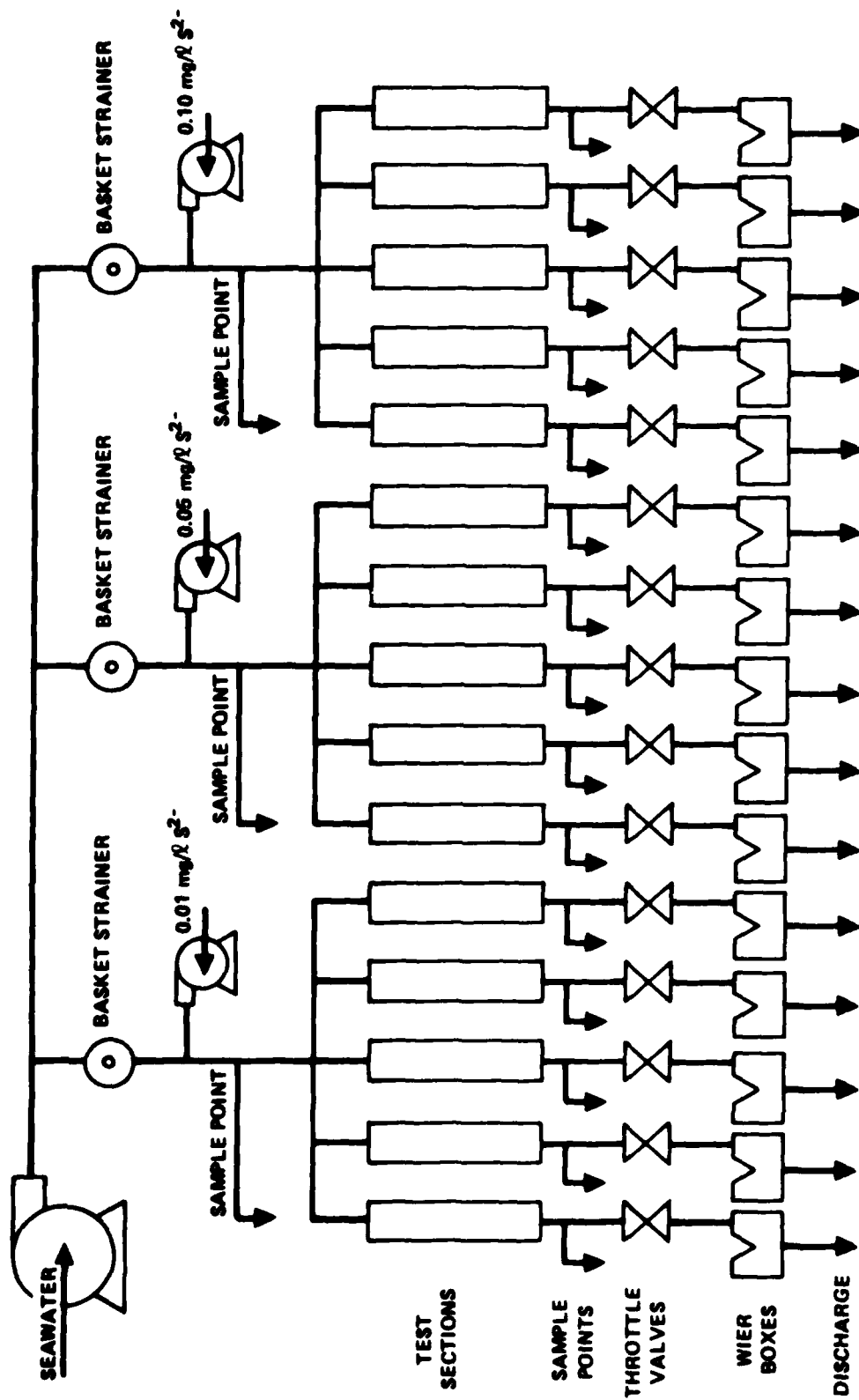

Figure 1 - Exposure Loop

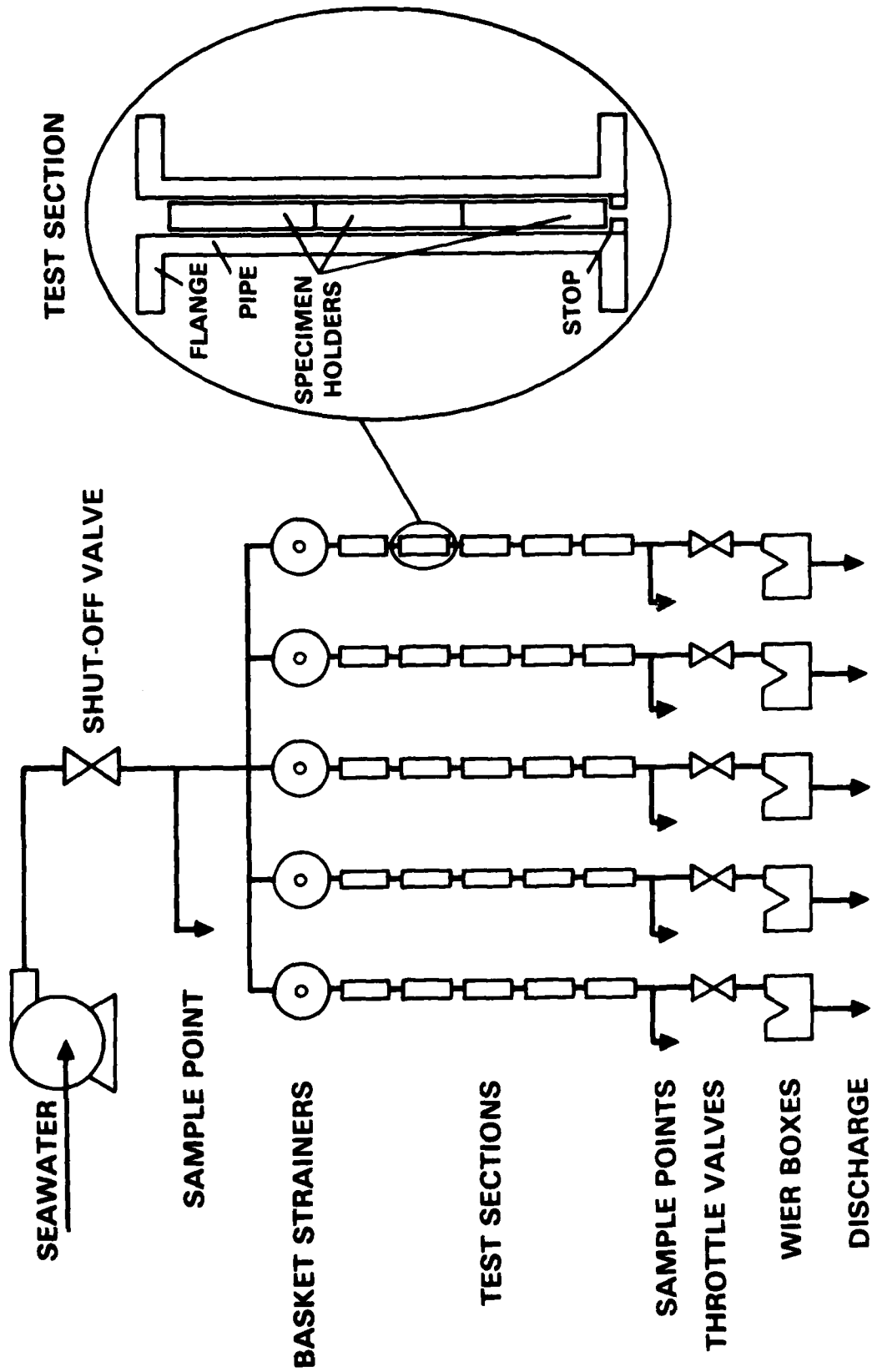

Figure 2 - Exposure Loop for Control Specimens

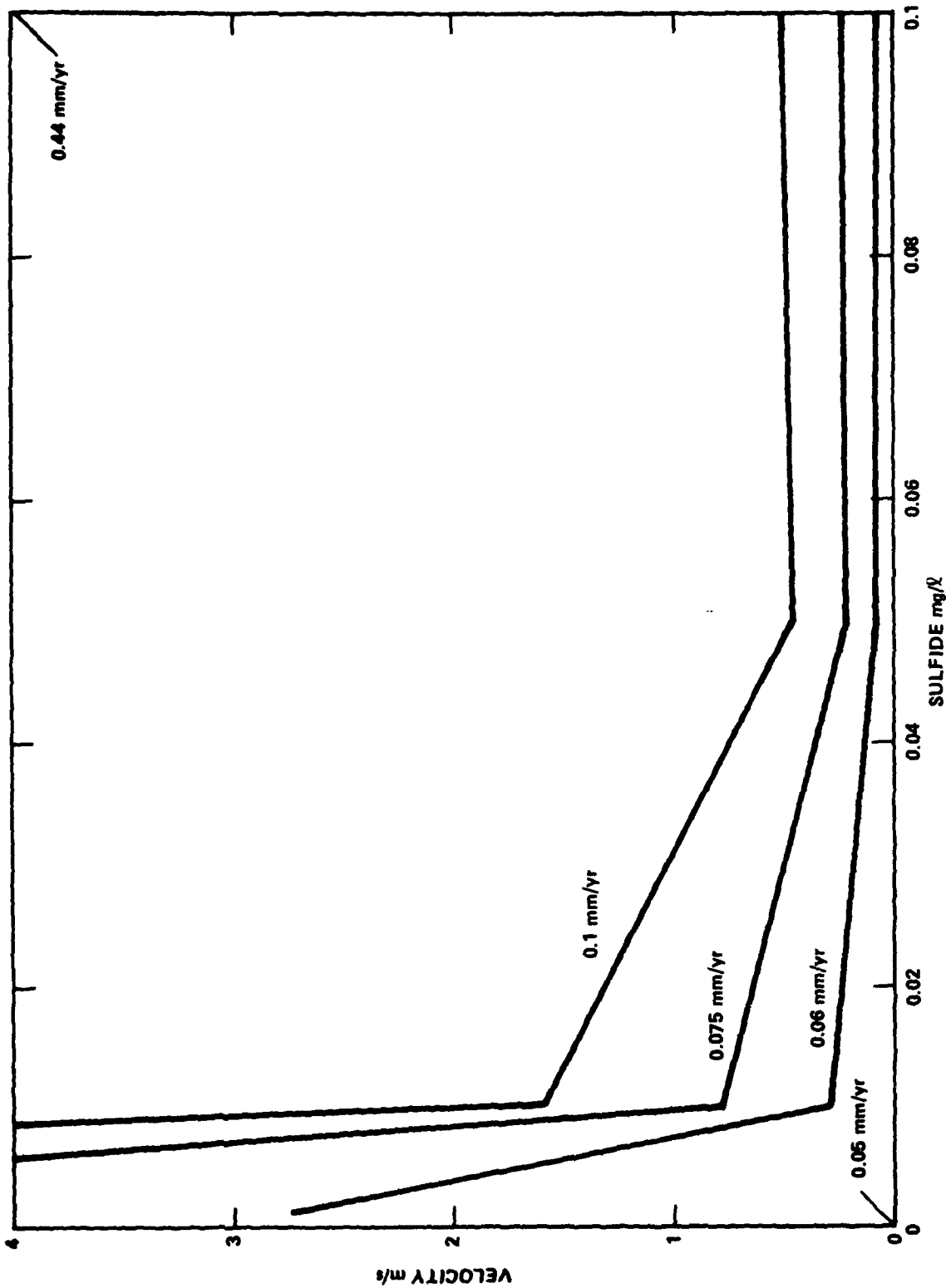

Figure 3 - Estimated Corrosion Rates for C70600 Specimens
Obtained by Cross-Plotting Regression Equations

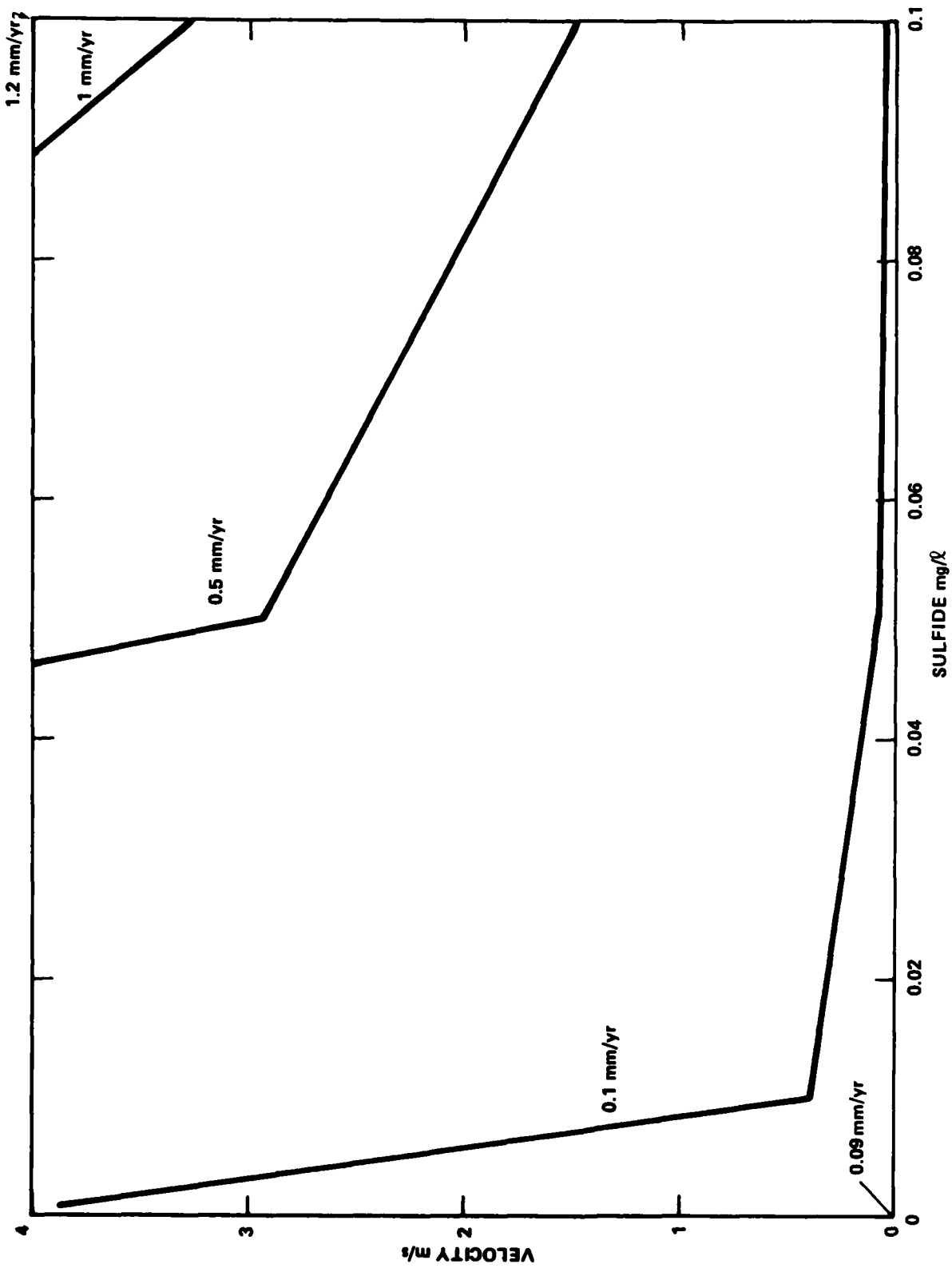

Figure 4 - Estimated Corrosion Rates for C71500 Specimens
Obtained by Cross-Plotting Regression Equations

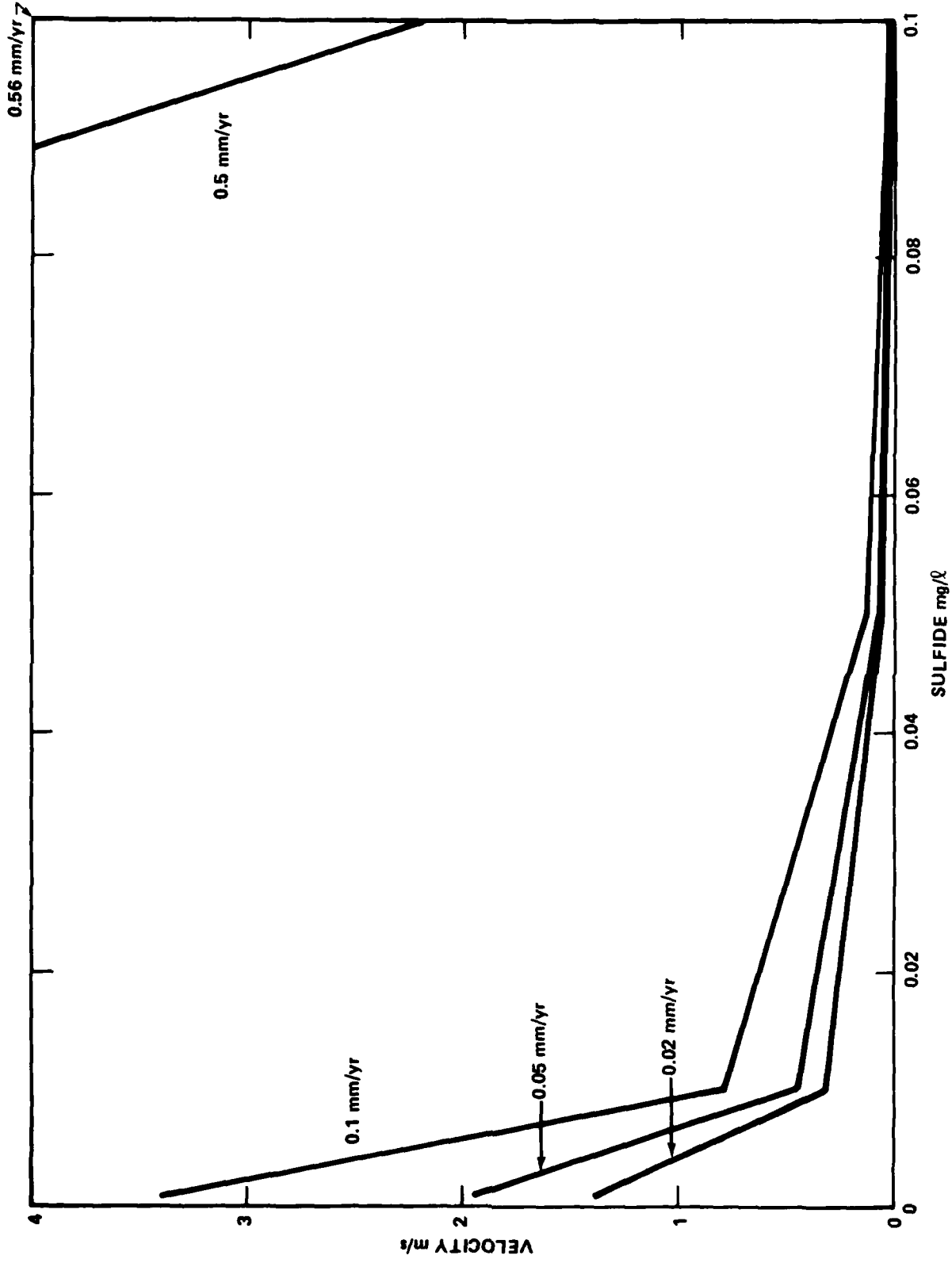

Figure 5 - Estimated Corrosion Rates for C7200 Specimens
Obtained by Cross-Plotting Regression Equations

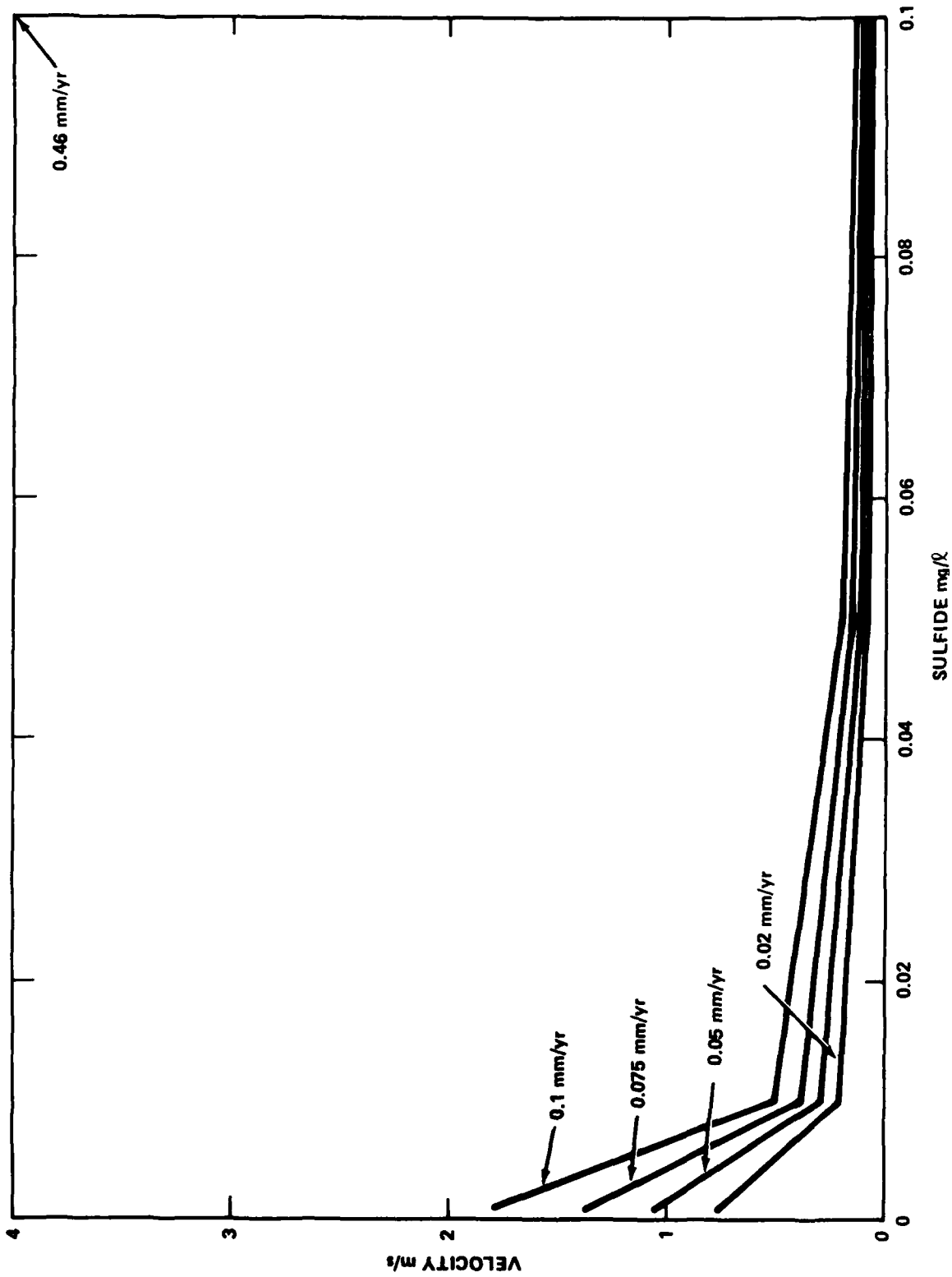

Figure 6 - Estimated Corrosion Rates for C68700 Specimens
Obtained by Cross-Plotting Regression Equations

REFERENCES

1. Sato, S., "Engineering Experience-Japanese Utility Industry," Paper Presented at Seminar on Condensers, Columbus, OH (2-4 June 1975)
2. Sato, S., "Corrosion and Its Prevention in Copper Alloy Condenser Tubes Under Modern Conditions," Reviews on Coatings and Corrosion, Freund Publishing House LTD., Tel-Aviv, Israel
3. Newton, E. H., and J. D. Birkett, "Survey of Condenser Tube Life in Salt Water Service," Rept 278, Rept to the Office of Saline Water, Dept of Interior, Contract 1401-0001-956 (Aug 1967)
4. Schluter, J. M., "Copper Alloy Tube Failures in Sea Water Condensers (Case History)," Materials Performance, Vol. 17, No. 2 (Feb 1978)
5. Gudas, J. P., and H. P. Hack, "Sulfide-Induced Corrosion of Copper-Nickel Alloys," Corrosion, Vol. 35, No. 2 (Feb 1979)
6. Gudas, J. P., et al, "Accelerated Corrosion of Copper-Nickel Alloys in Polluted Water," Paper No. 76, Presented at Corrosion/76, Houston, TX (22-26 Mar 1976)
7. Bates, J. F., and J. M. Popplewell, "Corrosion of Condenser Tube Alloys in Sulfide Contaminated Brine," Corrosion, Vol. 31, No. 8 (Aug 1975)
8. LaQue, F. L., Marine Corrosion, Causes and Prevention, John Wiley & Sons, New York, pp. 122-123 (1975)
9. Kawai, K., "Study on 10% Copper-Nickel Condenser Tube Alloys," Journal of the Japan Copper and Brass Research Association, Vol. II, p. 119 (1972)
10. Sato, S., "Some Factors Affecting the Performance of Copper Alloy Condenser Tubes in Recent Steam Power Plants," Japan Journal of Thermal Power, Vol. 21, p. 295 (1970)
11. Gudas, J. P., and H. P. Hack, "Parametric Evaluation of Susceptibility of Cu-Ni Alloys to Sulfide-Induced Corrosion," Corrosion, Vol. 35, No. 6 (June 1979)
12. Strickland, J. D. H., and T. R. Parson, A Practical Handbook of Seawater Analysis, Bulletin 167, 2nd Ed., Fisheries Research Board of Canada (1972)
13. Lee, G. F., and W. Stumm, "Determination of Ferrous Fe in the Presence of Ferric Fe with Bathophenanthroline," Journal of American Water Works Association, Vol. 52, pp. 1567-74 (Dec 1960)
14. Hines, W. W., and D. C. Montgomery, Probability and Statistics in Engineering and Management Science, Ronald Ross, New York (1972)

INITIAL DISTRIBUTION

| Copies | | CENTER DISTRIBUTION | |
|--------|--------------------------------|---------------------|----------------|
| | | Copies | Code |
| 14 | NAVSEA | 1 | 28 |
| | 2 SEA 05D | 5 | 281 |
| | 2 SEA 05R | 10 | 2813 |
| | 2 SEA 08J | 6 | 2813 (H. Hack) |
| | 2 SEA 99612 | 1 | 2809H |
| | 2 PMS 378 | 2 | 2803 |
| | 2 PMS 389 | 1 | 2814 |
| | 2 PMS 392 | 1 | 282 |
| | | 1 | 286 |
| 2 | NAVSHIPYD NORFOLK VA | 1 | 522.2 |
| | 1 (Code 261, Bolden) | 1 | |
| | 1 (Code 267, Brooks) | 2 | 5231.1 |
| 2 | SUPSHIP NEWPORT NEWS | | |
| | (Code 280, Privett) | | |
| 3 | SUPSHIP PASCAGOULA | | |
| | 1 (Code 200) | | |
| | 1 (Code 261) | | |
| 1 | CO USS CALIFORNIA (CGN-36) | | |
| 1 | CO USS SOUTH CAROLINA (CGN-37) | | |
| 12 | DTIC | | |

DTNSRDC ISSUES THREE TYPES OF REPORTS

1. DTNSRDC REPORTS, A FORMAL SERIES, CONTAIN INFORMATION OF PERMANENT TECHNICAL VALUE. THEY CARRY A CONSECUTIVE NUMERICAL IDENTIFICATION REGARDLESS OF THEIR CLASSIFICATION OR THE ORIGINATING DEPARTMENT.

2. DEPARTMENTAL REPORTS, A SEMIFORMAL SERIES, CONTAIN INFORMATION OF A PRELIMINARY, TEMPORARY, OR PROPRIETARY NATURE OR OF LIMITED INTEREST OR SIGNIFICANCE. THEY CARRY A DEPARTMENTAL ALPHANUMERICAL IDENTIFICATION.

3. TECHNICAL MEMORANDA, AN INFORMAL SERIES, CONTAIN TECHNICAL DOCUMENTATION OF LIMITED USE AND INTEREST. THEY ARE PRIMARILY WORKING PAPERS INTENDED FOR INTERNAL USE. THEY CARRY AN IDENTIFYING NUMBER WHICH INDICATES THEIR TYPE AND THE NUMERICAL CODE OF THE ORIGINATING DEPARTMENT. ANY DISTRIBUTION OUTSIDE DTNSRDC MUST BE APPROVED BY THE HEAD OF THE ORIGINATING DEPARTMENT ON A CASE-BY-CASE BASIS.