

LEVEL

2



TECOM Project No. ✓ 9-CO-150-000-124
DPG Document No. DPG-TR-78-314 ✓
Test Sponsor NASA Langley Research Center

TECHNICAL REPORT
METHODOLOGY STUDY FOR THE DEVELOPMENT
OF A PASSIVE SAMPLER FOR
FIRE-RELEASED CARBON FIBERS

BY
WILLIAM A. PETERSON
F. L. CARTER
AND
JOHN H. WHITING

SDTIC
SELECTED
SEP 19 1980
D
C

MARCH 1980

U.S. ARMY DUGWAY PROVING GROUND
Dugway, Utah 84022

DISTRIBUTION UNLIMITED

This document has been approved
for public release and sale; its
distribution is unlimited.

AD A090096

DDC FILE COPY

DISPOSITION INSTRUCTIONS

DESTROY THIS DOCUMENT WHEN NO LONGER NEEDED
DO NOT RETURN IT TO THE ORIGINATOR

DISCLAIMER

THE FINDINGS IN THIS DOCUMENT ARE NOT TO BE CONSTRUED
AS AN OFFICIAL DEPARTMENT OF THE ARMY POSITION UNLESS
SO DESIGNATED BY OTHER AUTHORIZED DOCUMENTS. THE USE
OF TRADE NAMES IN THIS REPORT DOES NOT CONSTITUTE AN
OFFICAL ENDORSEMENT OR APPROVAL OF THE USE OF SUCH
COMMERCIAL HARDWARE OR SOFTWARE. THIS REPORT MAY NOT
BE CITED FOR PURPOSES OF ADVERTISEMENT

UNCLASSIFIED

SECURITY CLASSIFICATION OF THIS PAGE (When Data Entered)

REPORT DOCUMENTATION PAGE		READ INSTRUCTIONS BEFORE COMPLETING FORM
1. REPORT NUMBER TECOM Project No. 9-CO-150-000-124	2. GOVT ACCESSION NO. AD-A090 096	3. RECIPIENT'S CATALOG NUMBER
4. TITLE (and Subtitle) Methodology Study for the Development of a Passive Sampler for Fire-released Carbon Fibers	5. TYPE OF REPORT & PERIOD COVERED Final Methodology Report, Apr 1979 - Mar 1980	6. PERFORMING ORG. REPORT NUMBER DPG-TR-78-314
7. AUTHOR(s) William A. Peterson F. L. Carter John H. Whiting	8. CONTRACT OR GRANT NUMBER(s)	
9. PERFORMING ORGANIZATION NAME AND ADDRESS US Army Dugway Proving Ground ATTN: STEDP-MT-DA-T Dugway, UT 84022	10. PROGRAM ELEMENT, PROJECT, TASK AREA & WORK UNIT NUMBERS 534-03-23-01	
11. CONTROLLING OFFICE NAME AND ADDRESS National Aeronautics and Space Administration GFRAPO, Material Division, Mail Stop 231 NASA Langley Research Center, Hampton, VA 23665	12. REPORT DATE Mar 1980	13. NUMBER OF PAGES 25
14. MONITORING AGENCY NAME & ADDRESS (if different from Controlling Office)	15. SECURITY CLASS. (of this report) UNCLASSIFIED	15a. DECLASSIFICATION/DOWNGRADING SCHEDULE
16. DISTRIBUTION STATEMENT (of this Report) Distribution Unlimited		
17. DISTRIBUTION STATEMENT (of the abstract entered in Block 20, if different from Report)		
18. SUPPLEMENTARY NOTES		
19. KEY WORDS (Continue on reverse side if necessary and identify by block number) Carbon Fiber Samplers Sampler Efficiency CFS Isokinetic Flow Passive Sampler Fire Plume Sampling		
20. ABSTRACT (Continue on reverse side if necessary and identify by block number) A passive carbon fiber sampler was developed for in-plume sampling (near the source) of fire-released carbon fibers. The sampler was designed to operate in a high temperature turbulent environment and sample a high flux of soot and fibers without overloading and losing efficiency. Wind tunnel tests for the aerodynamics of the airflow through the sampling orifice were conducted for tunnel air speeds from 2.1 to 37.1 m/sec. The data from these tests indicate that airflow through the sampling orifice was near isokinetic when the tunnel air speed was 6 m/sec. When the tunnel air speed was 6 m/sec, a 16 percent		

DD FORM 1 JAN 73 1473 EDITION OF 1 NOV 65 IS OBSOLETE

UNCLASSIFIED

SECURITY CLASSIFICATION OF THIS PAGE (When Data Entered)

118100

1

UNCLASSIFIED

SECURITY CLASSIFICATION OF THIS PAGE(When Data Entered)

over-isokinetic condition was observed. Also, wind tunnel tests of sampling efficiency were conducted with carbon fibers 5 mm long and 8 μ m in diameter. For the efficiency tests, the wind tunnel air speeds were 3.0, 4.2, and 6.5 m/sec with the sampler positioned at 0, 30, and 45° from the direction of the tunnel airflow. The new sampler was compared to the standard DPG nylon mesh sampler and a recovery fraction of 0.94 was obtained from the efficiency test.

UNCLASSIFIED

SECURITY CLASSIFICATION OF THIS PAGE(When Data Entered)

ABSTRACT

A passive carbon fiber sampler was developed for in-plume sampling (near the source) of fire-released carbon fibers. The sampler was designed to operate in a high temperature turbulent environment and sample a high flux of soot and fibers without overloading and losing efficiency. Wind tunnel tests for the aerodynamics of the airflow through the sampling orifice were conducted for tunnel air speeds from 2.1 to 37.1 m/sec. The data from these tests indicate that airflow through the sampling orifice was near isokinetic when the tunnel air speed was <6 m/sec. When the tunnel air speed was >6 m/sec, a 16 percent over-isokinetic condition was observed. Also, wind tunnel tests of sampling efficiency were conducted with carbon fibers 5 mm long and $8\mu\text{m}$ in diameter. For the efficiency tests, the wind tunnel air speeds were 3.0, 4.2, and 6.5 m/sec with the sampler positioned at 0, 30, and 45° from the direction of the tunnel airflow. The new sampler was compared to the standard DPG nylon mesh sampler and a recovery fraction of 0.94 was obtained from the efficiency test.

Accession For	
NTIS GRA&I	<input checked="" type="checkbox"/>
DDC TAB	<input type="checkbox"/>
Unannounced	<input type="checkbox"/>
Justification	
By	
Distribution/	
Availability/	
Dist	
A	

FOREWORD

This study was conducted for the National Aeronautics and Space Administration, Langley Research Center, Hampton, VA. US Army Dugway Proving Ground, UT was responsible for the conduct of the study and preparation of the report. The technical efforts of the personnel at the DPG Life Science Laboratory are greatly appreciated.

TABLE OF CONTENTS

	<u>PAGE</u>
ABSTRACT	i
FOREWORD	ii
LIST OF TABLES	iv
LIST OF FIGURES	v

SECTION 1. SUMMARY

1.1 BACKGROUND	1
1.2 OBJECTIVES	1
1.3 CONCLUSIONS	1
1.4 RECOMMENDATIONS	2

SECTION 2. DETAILS OF STUDY

2.1 SCOPE	3
2.2 PROCEDURES	3
2.3 CFS RECOVERY FRACTION	17

SECTION 3. APPENDICES

A REFERENCES	A-1
B TEST DATA	B-1
C DISTRIBUTION LIST	C-1

LIST OF TABLES

<u>TABLE</u>		<u>PAGE</u>
1	ANALYSIS OF VARIANCE OF STANDARD DPG NYLON MESH SAMPLER RECOVERIES (COUNTS PER SAMPLER) FOR WIND TUNNEL CALIBRATION EXPERIMENT	12
2	AVERAGE SAMPLER RECOVERY, BY POSITION, FOR WIND TUNNEL CALIBRATION	13
3	AVERAGE SAMPLER RECOVERY, BY WIND SPEED, FOR WIND TUNNEL CALIBRATION	13
4	ANALYSIS OF VARIANCE OF SAMPLER RECOVERIES (COUNTS PER SAMPLER) FOR CFS CALIBRATION EXPERIMENT	14
5	AVERAGE POSITION SAMPLER RECOVERY, BY POSITION, FOR CFS CALIBRATION	15
6	AVERAGE SAMPLER (CFS AND STANDARD DPG NYLON MESH) RECOVERY, BY WIND SPEED	15
7	AVERAGE SAMPLER RECOVERY, BY POSITION, FOR THE REDUCED DATA SET OF THE CFS CALIBRATION EXPERIMENT	16
8	ANALYSIS OF VARIANCE OF SAMPLER RECOVERIES (COUNTS PER SAMPLER) FOR THE REDUCED DATA SET OF THE CFS CALIBRATION EXPERIMENT	16

LIST OF FIGURES

<u>FIGURE</u>		<u>PAGE</u>
1	DESIGN OF PASSIVE CARBON FIBER SAMPLER	4
2	STANDARD DPG NYLON MESH SAMPLER	5
3	MODEL FOR DETERMINATION OF THE COLLECTION EFFICIENCY OF PASSIVE CFS	7
4	SAMPLER TUBE WIND SPEED (V_s) DIVIDED BY $\cos \theta$ VERSUS WIND TUNNEL SPEED (V_0)	10
5	SAMPLING ARRAY FOR DETERMINING SAMPLING EFFICIENCY OF TWO DIFFERENT SAMPLERS, TEST SECTION OF WIND TUNNEL AT DPG	11

THIS PAGE INTENTIONALLY BLANK

SECTION 1. SUMMARY

1.1 BACKGROUND

An objective of the NASA/NAVY fire-released carbon fiber tests conducted at US Army Dugway Proving Ground (DPG), UT was to obtain an estimate of source strength. Ideally, source strength in-plume sampling should take place near the fire, but beyond the zone of carbon fiber oxidation. The environmental conditions in the preferred sampling area are:

- a. In-plume temperatures can be several hundred degrees centigrade near the burning source, decreasing with distance until ambient temperature is reached.
- b. The plume gases will be highly turbulent near the fire.
- c. The plume will have a high flux of soot from burning fuel and composite material, clumps of carbon fibers, and single carbon fibers.

To function correctly under these conditions, a sampler design must meet certain criteria. The sampler must be designed to avoid overloading with soot and fibers, and to avoid loss of efficiency over time. The sampler should at least sample the net flux, in the direction of travel, over the sampling period. The sampling area should be small with respect to the filtering area.

The standard DPG nylon mesh sampler does not meet the criteria for in-plume source strength sampling, necessitating development of the passive carbon fiber sampler (CFS).

A CFS was calibrated by establishing its aerodynamics and efficiency. The Radiation Pad (Rad Pad) wind tunnel at DPG and the wind tunnel at Brigham Young University (BYU), Provo, UT were used to establish the CFS aerodynamics. The carbon fiber collecting efficiency was determined only in the DPG wind tunnel. The maximum capability of the DPG wind tunnel is approximately 6.5 m/sec. Therefore, BYU wind tunnel was used for wind speeds >6.5 m/sec, to a maximum of 35 m/sec.

1.2 OBJECTIVES

The objectives of this project were to design and develop a passive carbon fiber sampler to determine its operational efficiency and aerodynamic characteristics.

1.3 CONCLUSIONS

The passive CFS design meets the criteria for in-plume source strength sampling of carbon fibers.

b. The CFS calibrated in the DPG wind tunnel had a recovery fraction of 0.94 compared to the standard nylon mesh DPG sampler. This recovery fraction is for collection of 5-mm long carbon fibers, with sampler angles of 0, 30, and 45° and wind speeds <6.5 m/sec.

c. Airflow through the sampling tube appears to be isokinetic with respect to tunnel airflow up to about 6 m/sec. Beyond 6 m/sec, an over-isokinetic flow of about 16 percent is observed. It was assumed that the over-isokinetic flow of 16 percent will not significantly affect the sampling efficiency of the CFS.

d. To overcome the problem of soot and fibers overloading the sampler and degrading sampling efficiency, the ratio of the area of the wire mesh cloth filter to sampling area is 182:1 (or 80:1 for effective open area).

1.4 RECOMMENDATIONS

If a significantly large test program is required in the future, it is recommended that an additional methodology study be conducted to determine loss of fibers over a spectrum of fiber lengths. Experience indicates that sampling efficiency is dependent on the length of fibers being sampled (Reference 1).

SECTION 2. DETAILS OF STUDY

2.1 SCOPE

The project consisted of designing and developing a passive carbon fiber sampler (CFS) for pool fire source strength tests. The aerodynamics and sampling efficiency were tested in wind tunnels.

2.2 PROCEDURES

Wind tunnel evaluation and theory have been presented in detail (Reference 2); no tunnel modifications were implemented.

2.2.1 Passive CFS

2.2.1.1 General Description of Passive Fire-Released CFS. The CFS consists of a cylindrical 16-gauge stainless steel outer casing containing a cylindrical wire mesh cloth (Figure 1). The outer casing is 25.4 cm in diameter and 50.8 cm long. An attached 15.3-cm cone section terminates on a sampling tube extending 7.6 cm into the casing. The internal attaching collar has an opening of 5.08 cm diameter. The wire mesh cylinder, which fits into the casing, is a 45.7-cm long, 20.32-cm diameter cylinder fabricated from 24-mesh stainless steel wire cloth. The cloth is a square weave purchased from Cambridge Wire Cloth Co., Cambridge, MD. The wire diameter is 0.356 mm with a 0.70-mm mesh opening between wires. The effective open area is 44.2 percent. One end of the filtering screen cylinder is fitted with a solid end plate to which a 5.1-cm diameter sampling tube is attached. The sampling tube extends forward 22.86 cm and 7.62 cm into the filter screen cylinder with the 7.6 cm length flared to a diameter of 7.62 cm. A wire cloth lid fits over the top opening of the screen. The screen section, with attached sampling tube, is placed in the outer casing and fastened in place by three set-screws imbedded in the attaching collar. A removable backplate baffle with a central opening of 7.62 cm fits into the back of the casing to complete the sampler.

The ratio of the sampling area of the sampling orifice to the filtering area of the wire mesh cloth is 1:182 (or 1:80 for effective open area).

The fibers are recovered from the wire mesh cloth filter by an air-washing technique. The screen and top of the CFS are placed in a cylindrical vacuum trap with a standard DPG nylon mesh sampler (Figure 2) in the bottom outlet of the air-wash. The fibers are dislodged from the screen by the vacuum in the air-wash and by blowing a gentle stream of air across the wire mesh cloth and sampling tube. After the air-washing is completed, the DPG nylon mesh sampler is recovered and assayed according to the appropriate DPG method for DPG nylon mesh samplers (Reference 1).

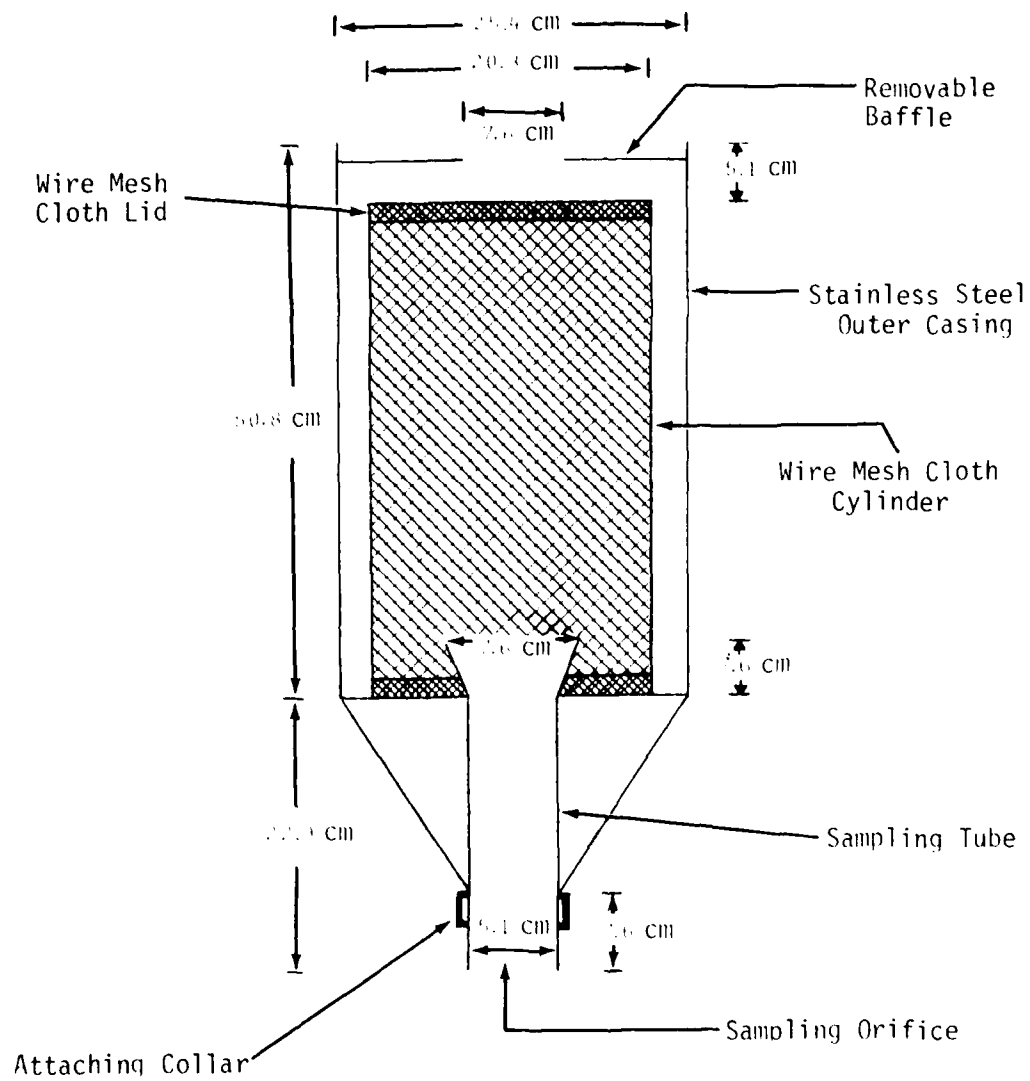

Figure 1. Design of Passive Carbon Fiber Sampler.

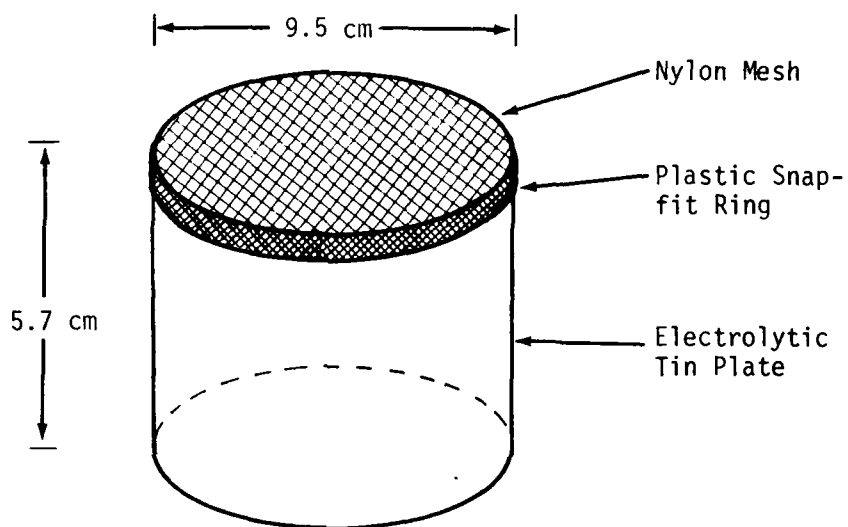

Figure 2. Standard DPG Nylon Mesh Sampler (Passive) Reference 1.

The sampler consists of a standard seamless cylinder of 0.5-mm electrolytic tin plate 5.7 cm high and 9.5 cm diameter. Nylon mesh consists of 17 monofilaments per 2.5 cm. For adhesion of fibers to the nylon mesh, the mesh is dipcoated in a mixture of lanolin, mineral oil, and toluene.

2.2.1.2. Method Used to Determine Sampler Efficiency. The physical model used to determine the sampling efficiency of the CFS versus the standard DPG nylon mesh sampler is shown in Figure 3.

The terms used for the physical model (Figure 3) are:

- V_o = the wind speed at the test section of the wind tunnel.
- C_o = the unperturbed concentration of the fibers immediately in front of the samplers.
- V_m = the air speed on the upwind surface on the mesh of the standard DPG nylon mesh sampler.
- V_s = the air speed immediately inside the sampling tube of the CFS.
- A_m = the effective orifice area of the standard DPG nylon mesh sampler.
- A_s = the orifice area of the CFS.
- C_s = the concentration of the fibers in the CFS sampling orifice.
- C_m = the concentration of fibers at the upwind surface of the mesh on the standard DPG nylon mesh sampler.

The numbers of fibers collected by the two samplers are given by:

$$N_m = \int A_m V_m C_m dt \text{ (standard DPG nylon mesh sampler)} \quad (1)$$

$$N_s = \int A_s V_s C_s dt \text{ (CFS)} \quad (2)$$

When wind speed and direction are constant, the Equations (1) and (2) can be written as:

$$N_m = A_m V_m E \int C_o dt \quad (3)$$

$$N_s = A_s V_s \int C_s dt \quad (4)$$

where $E = \text{efficiency} \left(\frac{C_m}{C_o} \right)$ of the standard DPG nylon mesh sampler

compared to an isokinetic sampler.

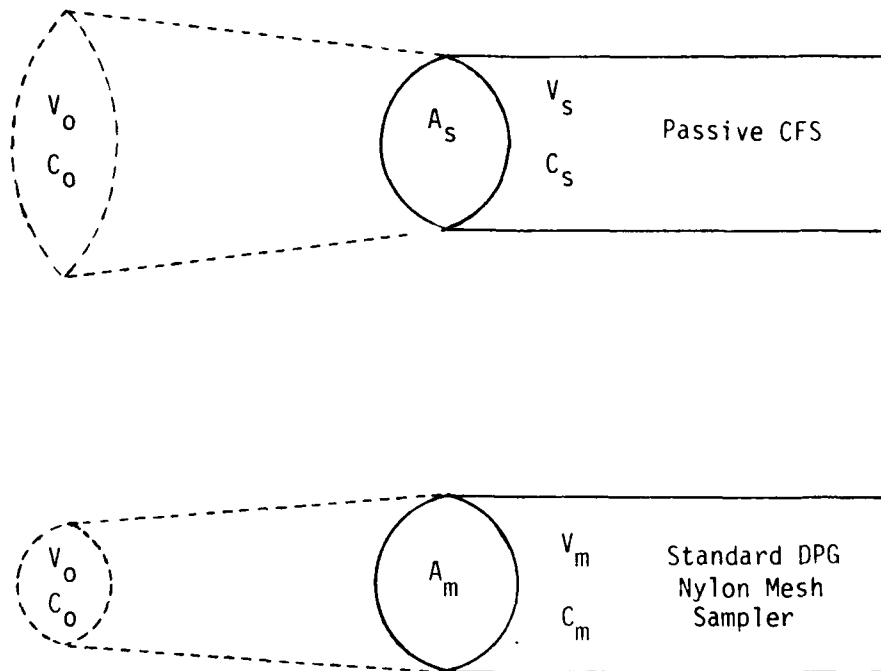

NOTE: See text for explanation of terms.

Figure 3. Model for Determination of the Collection Efficiency of Passive CFS.

For our situation

$$A_s = \frac{A_m}{4} \cos \theta \quad (5)$$

θ = the angle between the axis of the passive CFS and wind direction. For the standard DPG nylon mesh sampler $\theta = 0$.

Dosage, defined by $D = \int C_0 dt$, can be obtained by counting the number of fibers collected on the nylon mesh sampler (N_m) and using the following relation

$$D = \frac{N_m}{A_m V_m E} \quad (6)$$

It follows that if $A_m = 4 A_s / \cos \theta$

$$D = \frac{N_m \cos \theta}{4 A_s V_m E} \quad \text{or} \quad (7)$$

$$D = \frac{N_s}{A_s V_m E K} \quad (8)$$

$$\text{where } K = \frac{4 N_s}{N_m \cos \theta} \quad (9)$$

The objective of the calibration is to determine a value of k for different wind speeds and angles.

2.2.1.3 Sampler Calibration. The CFS calibration was divided into two parts. The primary purpose of the first part was to determine the aerodynamics of airflow through the CFS sampler tube. Once the aerodynamics were established, sampling efficiency was tested by subjecting the sampler to carbon fibers.

a. Aerodynamics. The first part of CFS calibration was conducted in the DPG and BYU wind tunnels with wind direction varying from normal to 45° and wind speeds 2 to 36 m/sec. A 0.32 cm (1/8-in) diameter stainless steel Pitot tube with an insertion length of 30.48 cm (12 in) was placed in the sampling tube with the tip of the Pitot tube 19.1 cm (7.5 in) from the sampler orifice. The Pitot tube was centered and aligned along the sampling tube center. Another Pitot tube in the wind tunnel

measured wind speeds near the sampler. Dynamic pressures measured by the Pitot tubes were recorded with a MKS Baratron. The Baratron is capable of recording changes of 0.0001 mm Hg dynamic pressure. The dynamic pressure (q) is given by

$$q = \left(\frac{V}{20.598} \right)^2 \left(\frac{P}{T + 460} \right) \quad (10)$$

where

- q = dynamic pressure (mm Hg)
- V = tunnel wind speed (m/sec)
- P = barometric pressure (millibars)
- T = air temperature ("F)

The data obtained from this test are prepared in Appendix Table B.1 and Figure 4. Appendix Table B.1 and Figure 4 indicates an isokinetic state up to about 6 m/sec and an above isokinetic airflow of 16 percent beyond 6 m/sec.

b. Efficiency. To determine sampler efficiency, the samplers were placed in DPG wind tunnel as shown in Figure 5. The sampling array in Figure 5 was used for 27 trials. Tunnel wind speeds were varied at 3.0, 4.2 and 6.5 m/sec for CFS angles of 0, 30, and 45°. Carbon fibers 5.0 mm long and 8 μ m in diameter were disseminated. An air blower (manufacturer's trade name: Skil) was used to disseminate the carbon fibers against the airstream to disperse the fibers across the test section of the wind tunnel. The results of these trials are present in Appendix Table B.2. The value of K is determined from the physical model and using data reduction for the average of the standard DPG nylon mesh samplers.

The maximum capability of the wind tunnel at DPG was 6.5 m/sec wind speed. The wind tunnel at BYU would not lend itself to sampler efficiency measurements with carbon fibers; consequently, it could not be used for this test.

2.2.1.4 Statistical Analysis of Wind Tunnel Data.

a. Calibration of the Wind Tunnel. Prior to calibrating any sampling devices, a test was performed to determine the uniformity of fiber concentrations for the sampling array in the test section of the wind tunnel. The test section of the DPG wind tunnel was arrayed (Figure 5) with standard DPG nylon mesh samplers (Figure 2). Three wind speeds (3.0, 4.2, and 6.5 m/sec) and three repetitions of each sampler position-wind speed treatment combinations were used. Because sampler positions were fixed, this was a split plot experiment with the sampler positions (whole plot) in "stripes" throughout the experiment. the "whole plots" were then split by the three wind speeds (sub-plots) (Reference 3).

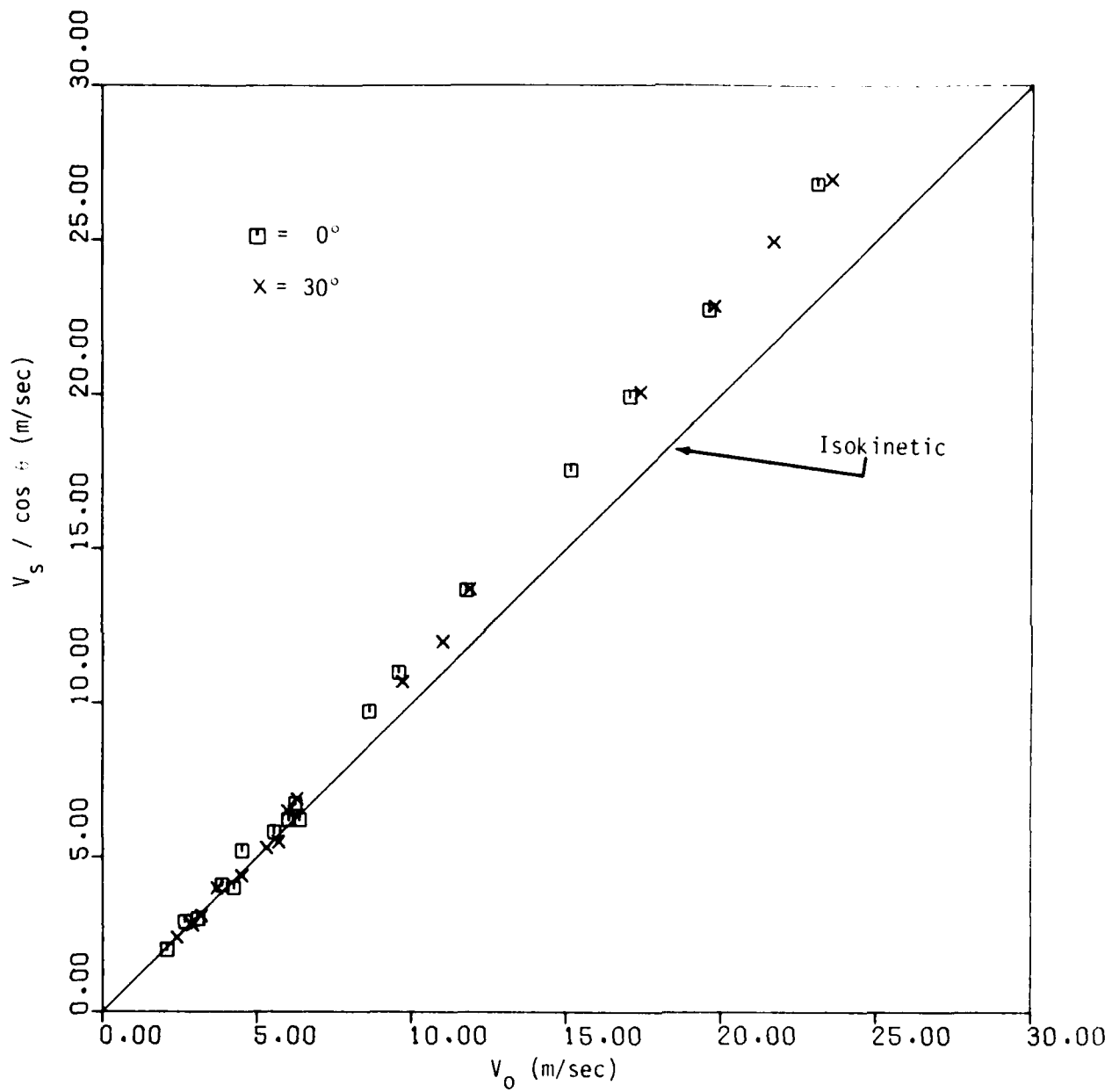

Figure 4. Sampler Tube Wind Speed (V_s) Divided by $\cos \theta$ versus Wind Tunnel Speed (V_0).

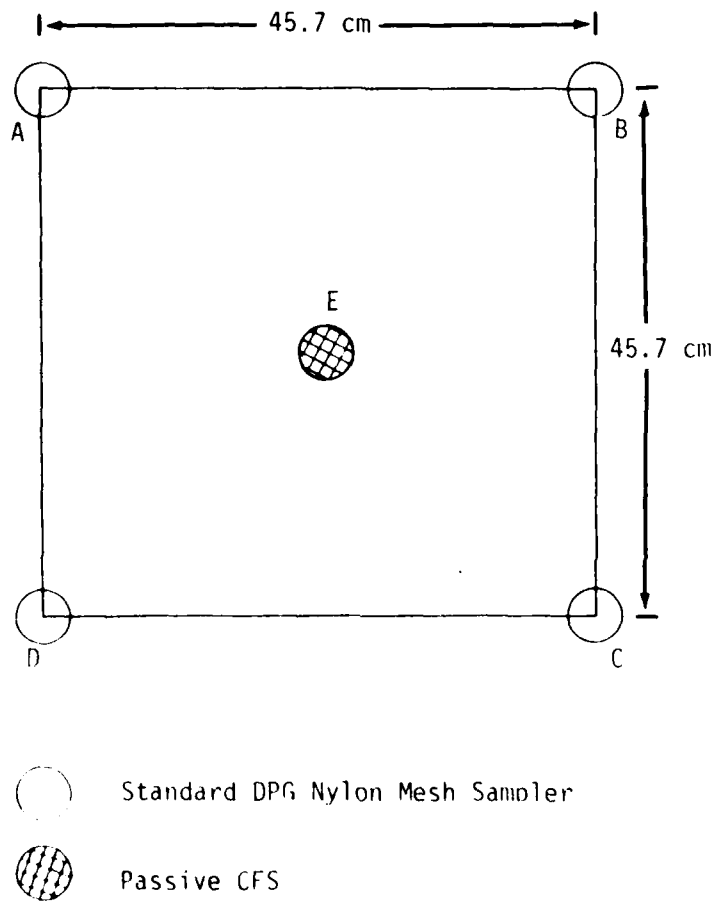

Figure 5. Sampling Array for Determining Sampling Efficiency of Two Different Passive Samplers, Test Section of Wind Tunnel at DPG.

Data collected from this experiment are shown in Appendix Table B.3. Following each wind tunnel test, the samplers were identified and assayed according to the appropriate DPG SOP for carbon fiber assessment.

An analysis of variance was performed to identify major sources of significant variation on total counts recovered from each sampler (Table 1). A study of assay variability was not an objective of this experiment; the assumption was made that assay variability was small in comparison to those sources of variation that were taken under consideration. Source strength variation is inherent in the trial variation and will be part of the Repetition/PxS effect in the analysis and/or Replication effect when it is present. The important feature of the analysis of variance is that these sources of variation are separated from those attributes that are of particular interest.

Table 1. Analysis of Variance of Standard DPG Nylon Mesh Sampler Recoveries (Counts per Sampler) for Wind Tunnel Calibration Experiment.

Source of Variation	Degrees of Freedom	Sums of Squares	Mean Square	F_{comp}	F_{tab}
Position (P)	4	220,852	55,213	4.53	3.84
Speed (S)	2	121,792	60,896	5.00	4.46
PxS	8	97,498	12,187	<1.00	Not Significant
Repetition/PxS	30	649,054	21,635		
Total	44	1,089,196			

In the last two columns of Table 1, F_{comp} exceeds F_{tab} , therefore a statistically significant difference among position and wind speed means was observed (5 percent significance level).

As shown in Table 2, the lower left sampling position average was statistically different from the upper right sampling position average recovery. Although the lower right sampling position average recovery was not statistically different from the other average recoveries, it was numerically lower than the upper three positions, showing a bias to lower average recoveries in the lower sampler positions.

Table 2. Average Sampler Recovery, by Position (as shown in Figure 5), for Wind Tunnel Calibration.

698.3		737.1
	680.7	
543.9		626.1

Average recovery at the 3.0 m/sec wind speed was statistically lower than the average recoveries observed at either the 4.2 m/sec or 6.5 m/sec wind speeds. The average recoveries are shown in Table 3, by wind speed.

Table 3. Average Sampler Recovery, by Wind Speed, for Wind Tunnel Calibration.

Wind Speed (m/sec)	3.0	4.2	6.5
Average Recovery (Count/Sampler)	585.5	670.7	710.1

b. Calibration of the CFS. Because of the difference in size between the CFS and the standard DPG nylon mesh samplers, the CFS was placed in the center of the five-sampler array (Figure 4) and remained in that position throughout the experiment. Physical limitations precluded randomizing the CFS position over the five-sampler array in the wind tunnel. In a statistical sense, position and sampler were confounded. By utilizing the wind tunnel calibration data reported above, it could be assumed that any statistical differences involving the CFS could be attributed to the CFS rather than a position difference.

The standard DPG nylon mesh sampler was as described above and shown in Figure 2. The CFS was described in paragraph 2.2.1 and illustrated in Figure 1.

The wind speeds (3.0, 4.2, and 6.5 m/sec) were the same as used to calibrate the wind tunnel. The CFS was oriented at three angles to the wind (0°, 30°, and 45°). The CFS data were treated with a cosine correction factor. Angle effects were then considered to be replication effects. The collection area of the standard DPG nylon mesh sampler is four times that of the CFS and the CFS data were adjusted accordingly.

As with the wind tunnel calibration, this was a split-plot experiment where sampler positions (whole plot) were in strips; the whole plots were then split into sub-plots by the three wind speeds. Three repetitions of each position-wind speed treatment were performed and three replicates of the experiment were conducted.

Data collected from this experiment are shown in Appendix Table B.2. After each wind tunnel test, the samplers were identified and assayed according to the appropriate DPG SOP for carbon fiber assessment.

An analysis of variance (Table 4) was performed on total sampler recoveries, with the adjustments to the data as previously mentioned.

Table 4. Analysis of Variance of Sampler Recoveries (Counts per Sampler) for CFS Calibration Experiment.

Source of Variation	Degrees of Freedom	Sums of Squares	Mean Square	F _{comp}	F _{tab}
Replication (R)	2	1,566,010	783,005	144.58 ^a	4.46
Position (P)	4	226,865	56,716	10.47 ^a	3.84
RxP	8	43,324	5,416	0.25	2.59
Speed (S)	2	472,707	236,353	11.73 ^a	3.63
PxS	8	170,973	21,372	1.06	2.59
RxS	4	399,912	99,978	4.96 ^a	3.01
RxPxS	16	322,502	20,156	0.92	1.80
Repetition/RxPxS	90	1,970,654	21,896		
Total	134	5,172,947			

^aThe probability that the observed difference is due to chance alone is <0.01.

In dealing with an analysis of variance, interaction terms must be dealt with first because certain significant interactions preclude discussion of main effects. In the analysis presented in Table 4, the only statistically significant interaction was replicate by wind speed. The interaction is the result of degree, i.e., the average replicate differences for each wind speed are of a different magnitude and there is one slight crossover. For this reason, the interaction was ignored so that inferences concerning main effects could be made. The most significant contribution to the overall analysis was that the replicate by wind speed variation and the replication main effect variation were isolated (and identified) from the total variation.

Position/sampler average recoveries shown in Table 5 are arrayed in the positions shown in Figure 5. The statistical analysis (Table 4) indicates that the lower right position (position C) average recovery is statistically lower than the center position (CFS) which is statistically lower than average recoveries observed at the other three positions (positions A, B, and D). It was anticipated that the border samplers (all DPG standard nylon mesh samplers) would maintain the average recovery order (i.e., lower left position with statistically lower recovery than the upper right). However, this was not the case. In an attempt to resolve this situation, the statistically equal average recoveries were again averaged to form the ratio with the CFS sampler (see paragraph 2.3). The reason for the significantly lower recovery in the lower right position and the apparent reversal from the calibration phase is not known.

Table 5. Average Position Sampler Recovery, by Position (as shown in Figure 5), for CFS Calibration.

690.2		680.6
	644.3	
693.9		584.6

As observed in the wind tunnel calibration phase, the average recovery at the 3.0-m/sec wind speed was statistically lower than the averages observed at the 4.2- and 6.5-m/sec wind speeds. The average recoveries are shown, by wind speed, in Table 6.

Table 6. Average Sampler (CFS and Standard DPG Nylon Mesh) Recovery, by Wind Speed.

Wind Speed (m/sec)	3.0	4.2	6.5
Average Recovery (Count/Sampler)	575.6	691.8	708.8

To resolve the problems caused by the reversal of the significantly low recovery from the lower left position to the lower right position between the tunnel calibration phase and the CFS calibration phase, an analysis was performed with a reduced set of CFS data. The data set was reduced by deleting the first replicate (because it made the greatest contribution to the significant replicate mean square), the 3.0 m/sec wind speed (for the above reason), and sampling positions C and D (because they contributed to significance in the wind tunnel calibration and CFS calibration, respectively). Because the data components contri-

buting the greatest amount to the significant variation (in each instance) were deleted, it was anticipated that statistical differences would not be observed. However, the power of the analysis was also reduced.

A significant replication effect is still present, however all other significant effects have vanished, either because of the correct deletion of data or because of the weakened analysis. The averages by sampling position (Figure 5) are shown in Table 7.

Table 7. Average Sampler Recovery, by Position (as shown in Figure 5), for the Reduced Data Set of the CFS Calibration Experiment.

844.42	780.75	789.00
--------	--------	--------

The analysis of variance for the CFS reduced data set is shown in Table 8.

Table 8. Analysis of Variance of Sampler Recoveries (Counts per Sampler) for the Reduced Data Set of the CFS Calibration Experiment.

Source of Variation	Degrees of Freedom	Sums of Squares	Mean Square	F _{comp}	F _{tab}
Replication (R)	1	188,645	188,645	37.37 ^a	18.5
Position (P)	2	28,770	14,385	2.85	19.0
RxP	2	10,097	5,048	<1.00	19.0
Speed (S)	1	23,922	23,922	1.29	18.5
PxS	2	21,486	10,743	6.20	18.5
RxS	1	114,695	114,695	1.00	19.0
RxPxS	2	37,012	18,506	<1.00	3.40
Repetition/RxPxS	24	795,105	33,129		
Total	35	1,219,732			

^aThe probability that the observed difference is due to chance alone is 0.05.

2.3 CFS RECOVERY FRACTION

An average recovery fraction for the CFS was determined from data in Table 5. As previously stated, the lower right position (position C) average recovery was statistically lower than the average recovery for the other border samplers (positions A, B, and D). Therefore, the average recovery of position C was not used for determining a CFS recovery fraction.

The recovery fraction for the calibration, 0.94 for tunnel wind speeds of 3.0, 4.2, and 6.5 m/sec., is the ratio of the CFS average to the average of the border nylon mesh sampler position (A, B, and D, Table 5) averages. This produces a consistent result with equation 9.

From the data in Table 7 which lists the average sampler recovery (by position) for the reduced data set, a CFS recovery fraction of 0.96 was obtained.

APPENDIX A. REFERENCES

1. Salomon, Lothar L., John D. Trethewey, and Melvin J. Bushnell, Evaluation of Clouds of Airborne Fibers (AD785675), The Army Science Conference Proceedings, 18 - 21 June 1974, Volume III Principal Authors S thru Z (AD785675), United States Military Academy, West Point, NY.
2. Deseret Test Center, Fort Douglas, Utah, DPG Wind Tunnel Modification and Evaluation, by E. G. Peterson, Dr. E. E. Covert, and D. L. Hansen, DTC-TR-73-703, October 1972.
3. Cochran, William G. and Gertrude M. Cox, Experiment Designs, 2nd Ed., John Wiley and Sons, Inc., New York. pp. 306 - 309, 1957.

THIS PAGE INTENTIONALLY BLANK

APPENDIX B. TEST DATA

Table B.1. Aerodynamic Data of Wind Tunnel Air Speeds (V_0) Versus Sampler Tube Air Speeds (V_s) at Sampler Angles 0, 30, and 45°.

Sampler Angle to Wind Direction 0°			Sampler Angle to Wind Direction 30°			Sampler Angle to Wind Direction Between 45 - 50°		
Tunnel Air Speed (V_0) m/sec	Sampler Tube Air Speed (V_s) m/sec	V_s/V_0	Tunnel Air Speed (V_0) m/sec	Sampler Tube Air Speed (V_s) m/sec	V_s/V_0	Tunnel Air Speed (V_0) m/sec	Sampler Tube Air Speed (V_s) m/sec	V_s/V_0
2.1	2.0	0.95	2.4	2.1	0.88	2.4	1.5	0.64
2.7	2.9	1.07	2.9	2.4	0.83	2.9	1.7	0.60
3.1	3.0	0.97	3.2	2.7	0.84	3.3	2.1	0.64
3.9	4.1	1.05	3.7	3.5	0.94	4.1	2.7	0.66
4.2	4.0	0.95	4.5	3.8	0.84	4.5	2.5	0.56
4.8	5.2	1.08	5.3	4.6	0.88	5.0	3.1	0.62
5.6	5.8	1.04	5.7	4.8	0.84	5.7	3.8	0.67
6.0	6.2	1.03	6.0	5.6	0.93	6.1	4.0	0.66
6.4	6.2	0.97	6.3	6.0	0.95			
6.2	6.7	1.08	9.7	9.3	0.96			
8.6	9.7	1.13	11.0	10.4	0.95			
9.6	11.0	1.14	11.9	11.9	1.00			
11.8	13.6	1.15	17.4	17.4	1.00			
15.1	17.6	1.16	19.8	19.8	1.00			
17.0	20.0	1.17	21.7	21.7	1.00			
19.6	22.8	1.16	23.6	23.4	0.99			
23.1	26.8	1.16	32.6	32.6	1.00			
32.0	37.1	1.16	35.6	36.3	1.02			

Test in excess of 6.1 m/sec were conducted at BYU. Physical dimensions of the tunnel precluded angles beyond 30°.

Table B.2. Total Counts of Carbon Fibers Recovered During Wind Tunnel Calibration of CFS.

REPLICATION	WIND SPEED (m/sec)	REPETITION	WIND TUNNEL POSITION				
			A	B	C	D	E
1	3.0	1	384	443	507	360	500
		2	407	373	311	355	408
		3	586	629	520	381	468
	4.2	1	600	640	541	614	552
		2	543	604	436	414	464
		3	483	527	416	437	608
	6.5	1	361	476	497	375	372
		2	1002	567	775	398	580
		3	613	801	553	504	512
2	3.0	1	675	720	681	671	679
		2	864	706	849	770	615
		3	702	389	956	597	656
	4.2	1	737	803	993	749	938
		2	822	786	702	447	711
		3	652	683	840	567	735
	6.5	1	591	894	674	531	716
		2	420	423	399	508	301
		3	982	1000	867	948	988
3	3.0	1	467	433	520	427	538
		2	549	572	821	743	634
		3	671	623	766	535	442
	4.2	1	935	938	817	759	747
		2	907	916	995	680	640
		3	731	655	1044	636	685
	6.5	1	793	333	766	864	978
		2	978	1127	822	763	968
		3	920	1075	662	752	962

Table B.3. Total Counts of Carbon Fibers Recovered During Wind Tunnel Calibration Analysis

WIND SPEED (m/sec)	REPETITION	WIND TUNNEL POSITION				
		A	B	C	D	E
3.0	1	550	483	519	403	670
	2	772	527	447	618	689
	3	760	646	549	619	530
4.2	1	667	539	457	590	584
	2	797	777	647	760	683
	3	734	734	653	707	731
6.5	1	512	748	289	381	521
	2	943	885	748	682	963
	3	899	946	505	875	755

THIS PAGE INTENTIONALLY BLANK

APPENDIX C. DISTRIBUTION LIST

<u>Addressee</u>	<u>Copies</u>
Commander US Army Test and Evaluation Command ATTN: DRSTE-AD-M Aberdeen Proving Ground, MD 21005	2
National Aeronautics and Space Administration GFRAPO, Material Division, Mail Stop 231 ATTN: Richard A. Pride NASA Langley Research Center Hampton, VA 23665	5
Commander Naval Surface Weapons Center ATTN: Code CF-56 (John H. Meyers) Dahlgren, VA 22448	2
Administrator Defense Documentation Center Cameron Station Alexandria, VA 22314	2
Commander US Army Dugway Proving Ground Dugway, UT 84022	24
(Distribute as follows)	
ATTN: STEDP-CO	(1)
-SD	(1)
-PP	(1)
-QA	(1)
-MT	(1)
-MT-DA	(1)
-MT-DA-T	(16)
-MT-DA-L	(2)