

AD-A090 640

BOEING AEROSPACE CO SEATTLE WA
MX TRANSPORTER EMPLACER GUIDANCE AND CONTROL, (U)
JUN 80 R D POYNEER, M E VANDEHEY

F/6 13/6

F04704-78-C-0035

UNCLASSIFIED

NL

1 of 1
of
about



END
DATE
FILMED
11 80
DTIC

AD A090640

LEVEL II

(1)

(6) MX TRANSPORTER EMPLACER
GUIDANCE AND CONTROL

(10) R. D. Poyneer
M. E. Vandehey

(15) BOEING AEROSPACE COMPANY
SEATTLE, WASHINGTON

Contract No. R01704-78-C-0335

Jun 1979

(12) 37

DTIC
ELECTE
OCT 16 1980

S D

DISTRIBUTION STATEMENT A
Approved for public release;
Distribution Unlimited

DDC FILE COPY

OS 7616 4w 80 10 16 008

ABSTRACT

The MX Transporter Emlacer (TE) is the the largest rubber tired vehicle in the world. It is 165.5 ft long, 29.8 ft high, 21.8 ft wide and weighs 1,450,000 lbs. The TE was developed to provide test data for use in the design of a fleet of large vehicles that will be required to transport MX missiles between protective shelters. It was developed specifically for the vertical shelter MX basing mode, but has provided valuable information on the performance of large rubber tired vehicles applicable to other basing modes.

The TE required precise positioning to allow emplacement and removal of the capsule and testing has demonstrated that the automatic near shelter positioning system developed for the TE meets this accuracy requirement. The automatic control system developed for the TE in over-the-road mode allows road width to be determined almost entirely by driver performance, with relatively little additional road width required to provide for off tracking of the front and rear tractors.

TE test results demonstrate that a large rubber tired vehicle similar to the vehicles that will be deployed as part of the MX program can be positioned precisely at a shelter and can be steered with sufficient accuracy to minimize road costs.

Accession For	
NTIS GRA&I	<input checked="" type="checkbox"/>
DTIC TAB	<input type="checkbox"/>
Unannounced	<input type="checkbox"/>
Justification	
By <i>Per Ltr. on file</i>	
Distribution/	
Availability Codes	
Avail and/or	
Dist	Special
A	

NOMENCLATURE

AR	Unfiltered Rear Steering Command
BR	Rear Brake Command
C	Cornering Coefficient (lbs/rad/tire)
CPU	Central Processing Unit
E-O	Electro-optical
ETB	Engineering Test Bed
g	Gravity Acceleration
HW	Heavy Weight
IFC	Interface Controller
IW	Intermediate Weight
MF	Front Engine Command
MPH	Miles Per Hour
MR	Rear Engine Command
MX	Missile Experimental
PF	Front Tag Axle Brake Voltage
RAD	Radians
RTU	Remote Terminal Unit
SF	Front Steering Command
SR	Rear Steering Command
TE	Transporter Emplacer
V	Velocity
VC	Velocity Command
VMF	Front Engine Voltage
X	Range to Target
\bar{X}	Mean
XS	Odometer Output Scaled
XSOD	Odometer Output Unscaled
YF	Front Steering Displacement
YR	Rear Steering Displacement
α_1	Front Tractor Angle
α_2	Rear Tractor Angle
σ	Standard Deviation
ψ	Azimuth Offset

INTRODUCTION

Most MX basing modes envision the deployment of a relatively small number of missiles in a large number of land-based hardened shelters. If the location of the missiles is kept secret, a potential adversary must destroy all shelters to ensure destruction of the missiles. A fleet of ground vehicles will be required to deceptively transport missiles from shelter to shelter.

The Transporter Emplacer (TE) was developed as a test vehicle for the MX program. It is a ground vehicle similar to the vehicles that will be deployed as part of the MX program. Although developed specifically for the vertical shelter basing mode, the TE has provided valuable test information that will be useful in the development of ground vehicles for any of the multishelter basing modes.

VEHICLE DESCRIPTION

The MX Transporter Emplacer (TE) shown in Figure 1 was designed to extract the missile from one vertical protective structure and transport it over a roadway to another vertical protective structure, where it would be emplaced. The TE vehicle built in 1979 is comprised of:

- (1) tractor facing forward,
- (2) tractor facing aft,
- (3) frame connecting the two tractors,
- (4) strongback on top of the frame and,
- (5) capsule (missile) inside the strongback.

The tractors were built by Terex (Division of General Motors). Each Tractor is powered by a 1000 horsepower Detroit diesel engine and it rides on twelve radial tires which are 8.5 feet in diameter and 2.3 feet wide. Two tires are on each of the front two steerable axles. Four tires are on each of the two unsteerable axles, the drive axles and the tag axle. Brakes are applied to all wheels on all axles. The tractors are identical except that the rear tractor has a power take off in its drive train to power equipment on the frame. Also, the rear tractor transmission is reversed (one speed forward and six speeds reverse).

The frame is a platform from which the strongback erects itself into a vertical position. The large linear actuator rotates the hoist end of the strongback up to 47° (strongback is pinned at the aft end of the frame). The translating carriage moves the pinned end of the strongback towards the center of the frame to complete the erection. The hoist at the top of the strongback lowers the capsule into the vertical protective structure. The strongback is then lowered to a horizontal position before the TE is moved.

The TE is the largest rubber tired vehicle in the world. Fully loaded it weighs 1,450,000 lbs. It is 165.5 feet long, 29.8 feet high and 21.8 feet wide. In its erected configuration it is 140.3 feet high.

CONTROL SYSTEM DEVELOPMENT

Controls development for the TE presented several unique design problems:

- 1) Automatic positioning at the shelter was required to be accurate enough to allow emplacement and removal of a missile. The requirement is unusual due to the accuracy required for such a large ground vehicle.
- 2) The TE is so long that tracking one end of the vehicle with respect to the other is a severe problem particularly in negotiating curves. The cost of increasing MX road widths is very expensive and vehicular offtracking must be kept to a minimum. A goal was established to keep the rear tractor offtracking small compared with variation in front driver performance.
- 3) Automatic control of a double tractor vehicle, especially the control of the trailing tractor in the reverse direction, presented control stability problems that required solution.

The control system developed for the TE solves all of these design problems. Two control systems were developed for the TE: The near shelter system to move the TE from about 250 feet away from the vertical shelter to directly over it and the over-the-road system to move the TE between shelter sites.

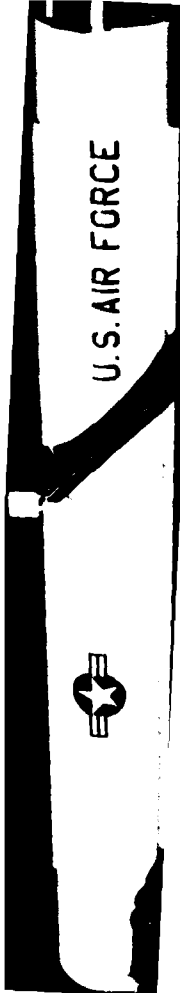

A variety of control modes were provided for maximum flexibility of the vehicle in the test program. The TE has three different shelter positioning modes, automatic, semi-automatic and manual. In the automatic mode the TE approaches the vertical shelter with no driver assistance. Steering, propulsion, and braking for both tractors are controlled by a computer. In the semi-automatic mode, the computer drives cab mounted displays to which each driver controls each tractor. The manual mode does not use the computer at all, but requires oral communication from personnel exterior to the vehicle.

The TE has two different over-the-road modes automatic and semi-automatic. In the automatic mode the rear tractor is controlled by the computer while in the semi-automatic mode the rear tractor is controlled by the rear driver who matches the output of a computer controlled display. In both modes the front tractor is controlled by the front driver.

The design philosophy for the command and control system was to design the simplest, least expensive control system which would do an adequate job controlling the vehicle. To minimize cost, a preference was shown to sensor systems that have minimal impact on road and shelter hardware requirements. This led to the selection of on-board vehicle sensors for over-the-road control and an electro-optical (E-O) sensor, requiring only inexpensive corner reflectors at each shelter, as the primary sensor for shelter positioning.

Near shelter controllers using one or two optical reflectors were considered. Two reflectors define a line that the vehicle can follow as it approaches the shelter. If angle and range are known to the two reflectors, the lateral, longitudinal, and angular position of the vehicle may be controlled. Control is also possible with a single reflector placed at the center of the vertical shelter. Since a single reflector does not define a line, vehicle angular orientation may not be controlled. Final angular position of the vehicle is a function of vehicle initial position and accumulated angular error. Final lateral and longitudinal position, however, may be accurately controlled. Since angular alignment requirements for the vehicle were moderate ($\sim 2^\circ$) either single or double reflector control met system requirements. The single reflector method was selected because of its simpler and more reliable electro-optical hardware/software requirements.

The near shelter lateral control law consisted of steering the front and rear tractors proportional to leading offsets of each tractor from a line defined by the position of the optical sensor and the reflector. Using this controller, stable operation of both tractors is obtained. Tractor angles (angles between the frame and tractor) are required to compute the leading offsets. The control law equations are presented below:

$$\begin{aligned} \text{PSI} &= \text{ALPHA} + (\text{YCAL}/\text{XSM}) + \text{PSICAL} \\ \text{SF} &= -\text{GS1} * (\text{KSF1} * \text{PSI} + \text{KSF2} * \text{AL1}) \\ \text{SR} &= \text{GS2} * (-\text{KSR1} * \text{PSI} + \text{KSR2} * \text{AL2}) \end{aligned}$$

where ALPHA is uncalibrated azimuth angle; PSI is calibrated azimuth angle; YCAL and PSICAL are calibration constants; XSM is range; SF and SR are front and rear steering angle commands; AL1 and AL2 are front and rear tractor angles. The remaining variables are control gains.

Near shelter longitudinal control used range and velocity measurements from the optical sensor to provide feedback to the front engine and rear brakes. Longitudinal control is a three-stage operation:

- 1) Acceleration to approach velocity
- 2) Maintain constant velocity
- 3) Deceleration to stop at desired position.

The front engine is actively controlled during the first two stages while the rear brakes are actively controlled in the final stage. During the critical third stage, velocity is controlled proportional to the square root of the target distance, yielding a nominally constant deceleration to the final position. The near shelter controller is shown schematically in Figure 2.

Two principal over-the-road control laws were considered, dynamic road mapping and angle lag control. Dynamic road mapping computes and updates a map of the road as a function of the travel of the leading tractor. Roadway points passed over by the leading tractor are projected backward based on steering angle and odometer sensor readings. The trailing end of the vehicle is controlled to follow the map. The angle lag controller controls the steering in the trailing tractor to match the tractor angles (angles of the tractor with respect to the frame) of the two tractors. To reduce control transients into and out of curves, the leading tractor angle is lagged as a function of distance travelled with an odometer dependent digital filter.

Analysis and simulation indicated that both over-the-road control laws were sufficient to meet tracking and stability design goals. The decision was made to use the angle lag controller because of its simplicity. The control equations are presented below:

$$ALSM = XS * AFLT * (AL1 - ALSM_{-1}) + ALSM_{-1}$$

$$SR = GTR1 * ALSM + GTR2 * AL2$$

where ALSM is the lagged front tractor angle; XS is the change in odometer reading; AFLT is a filter constant; AL1 and AL2 are tractor angles; SR is rear steering angle command; GTR1 and GTR2 are control gains. Over the road lateral control is shown schematically in Figure 3. Longitudinal control in the over-the-road mode consisted simply of relaying driver brake and throttle commands from the leading to the trailing tractor.

Semiautomatic control laws are similar to the automatic control laws, except that drivers observing steering and speed correction displays provide the control feedback. Near shelter longitudinal control however, does not use the automatic control law although it uses the same sensor. It is accomplished by providing the drivers with a display of distance to go.

Manual near shelter positioning is accomplished by positioning observers under the vehicle who give the driver instructions over an intercom.

CONTROL SYSTEM HARDWARE DESCRIPTION

The control system hardware summarized in Figure 4 consists of a distributed computer system that communicates with sensors and actuators. The central control computer is a ROLM 1603 computer that was provided as a part of the electro-optical sensing system. It is used both for optical sensor calculation and for most of the control law computations. The central computer communicates with a bit slice microprocessor that is in immediate control of the optical sensor operations, with the interface controller (IFC), and with various other interface equipment including a teletype, line printer and paper tape reader. The central computer and its interfacing equipment are all located in a command and control enclosure suspended beneath the frame. The IFC controls communication to two remote terminal units (RTUs) located in the cabs of each tractor. The remote terminal units control communication to and from sensors, actuators, and the display panel located in each tractor and are involved in some of the control law computations. The IFC and the RTU are all System 80/20 computers based on the 8080A microprocessor chip.

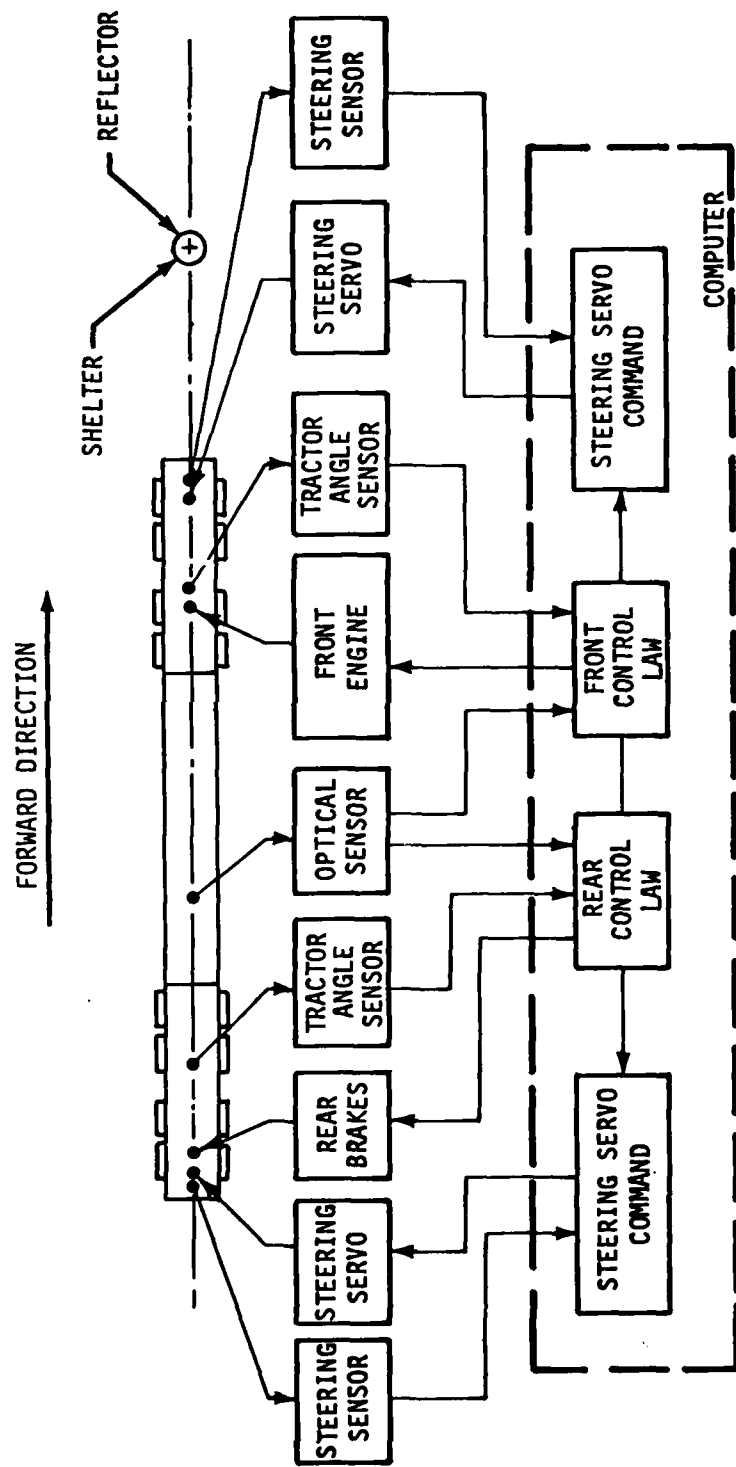

FIGURE 2 NEAR SHELTER INFORMATION FLOW

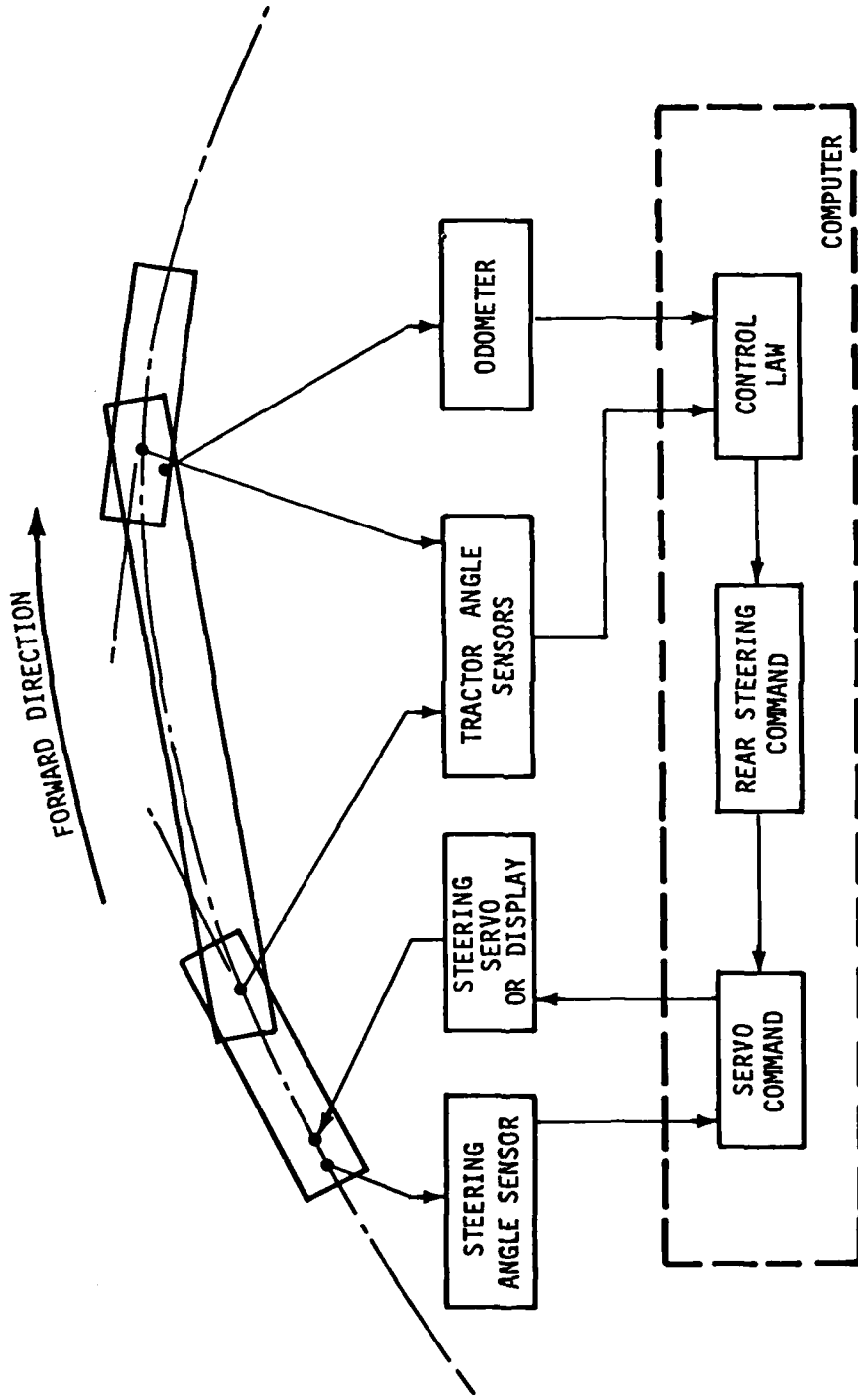

FIGURE 3 OVER - THE - ROAD LATERAL CONTROL

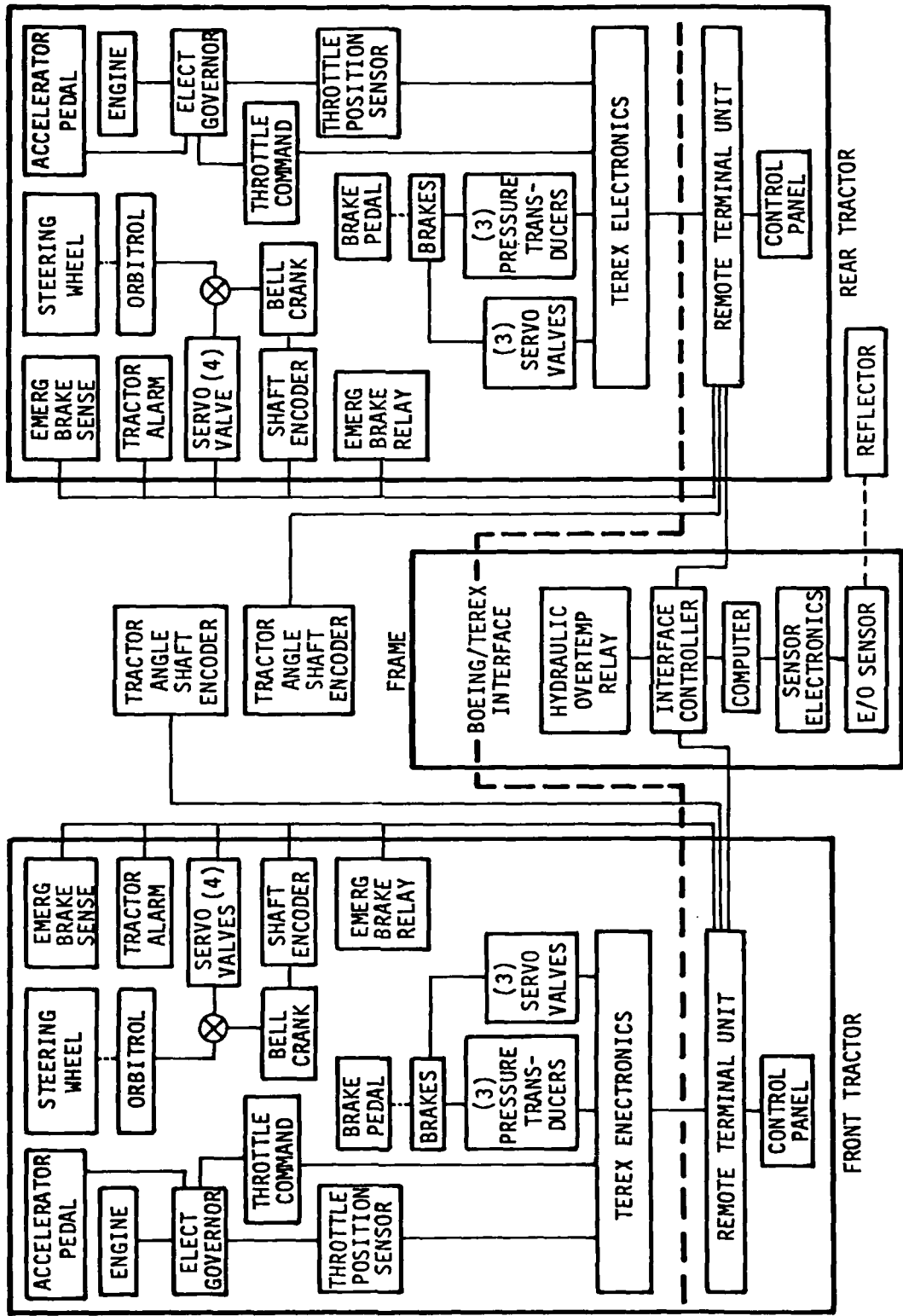

FIGURE 4 TE COMMAND AND CONTROL

The electro-optical sensor is a helium-neon laser tracking system that was originally designed for aerial refueling of airplanes and was adapted for the present application. The sensor, mounted at the base of the command and control enclosure, maintains track with a corner reflector at the center of the vertical shelter. Angle to the reflector is measured with an image dissector tube. Range is determined by measuring phase shift of the modulated laser light. Angle and range resolutions are 0.2 milliradian and 0.2 inch, respectively.

The measurements of tractor angles, steering angles and tag axle rotational angles (odometers) were acquired using 13 bit optical shaft encoders which measure rotations as small as 0.767 milliradian. The tractor angle sensors are located in the hitches that support the frame at each end.

All actuators may be controlled manually by a driver or automatically via the RTUs. The steering actuators are hydraulic actuators controlled either by a servo valve or from the steering wheel's orbitrol (metering valve). The hydraulically actuated disc brakes accepts commands from both the computer and from the brake pedals. The electronic governor on the diesel engine accepts computer commands or accelerator pedal inputs.

The display panels which are above the dashboard in each tractor are shown in Figure 5. The display panel is used for mode selection, system monitoring, fault indication and as a driver aid in semi-automatic mode.

CONTROLS ANALYSIS

Digital computer simulations were developed for both a maneuverability simulation for the near shelter control mode and a roadability simulation for over-the-road mode. The simulations were used to test control laws, set control gains, perform failure analysis and provide performance predictions.

The maneuverability simulations are shown schematically in Figure 6. Since there is very little coupling between lateral and longitudinal control if speed is slow and steering angles are small, separate lateral and longitudinal simulations were developed.

The longitudinal simulation modeled all control stages:

<u>STAGE</u>	<u>FUNCTION</u>
1A	Overcome static forces
1B	Accelerate to cruising speed
2	Hold speed constant
3	Decelerate to stop

Models of sensors, actuators, control laws, and vehicle dynamics were included in the simulation.

The lateral simulation was based on a kinematic model of lateral performance with the assumption that tire slip angle is negligibly small. A speed profile was input to the lateral model. Models of all steering sensors and actuators were included.

Control gains were selected using the lateral and longitudinal near shelter models to yield well damped control, high positioning accuracy and insensitivity to sensor inaccuracy and change in vehicle mass.

The over-the-road simulation is shown schematically in Figure 7. The vehicle dynamic model was a planar model including the following degrees of freedom:

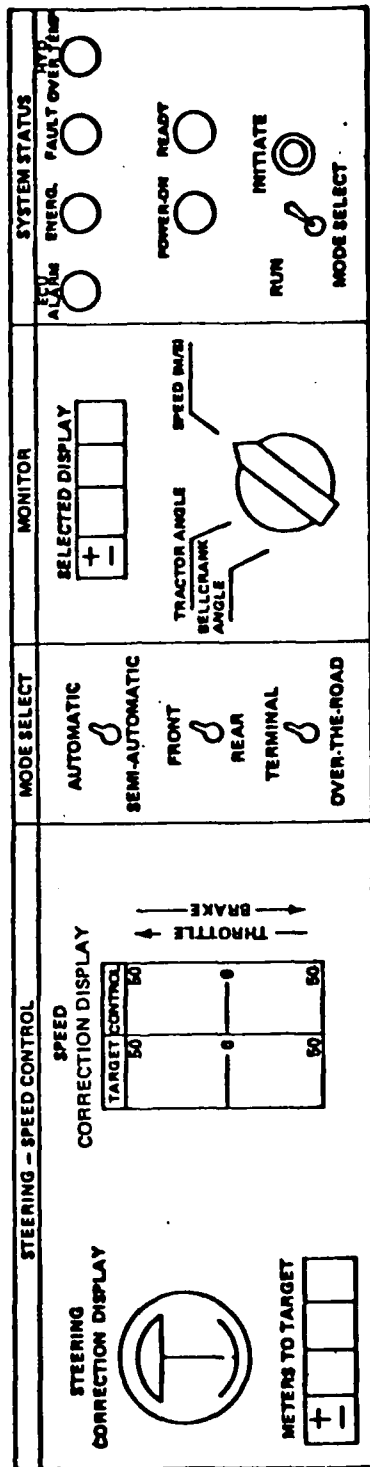

FIGURE 5 CONTROL PANEL

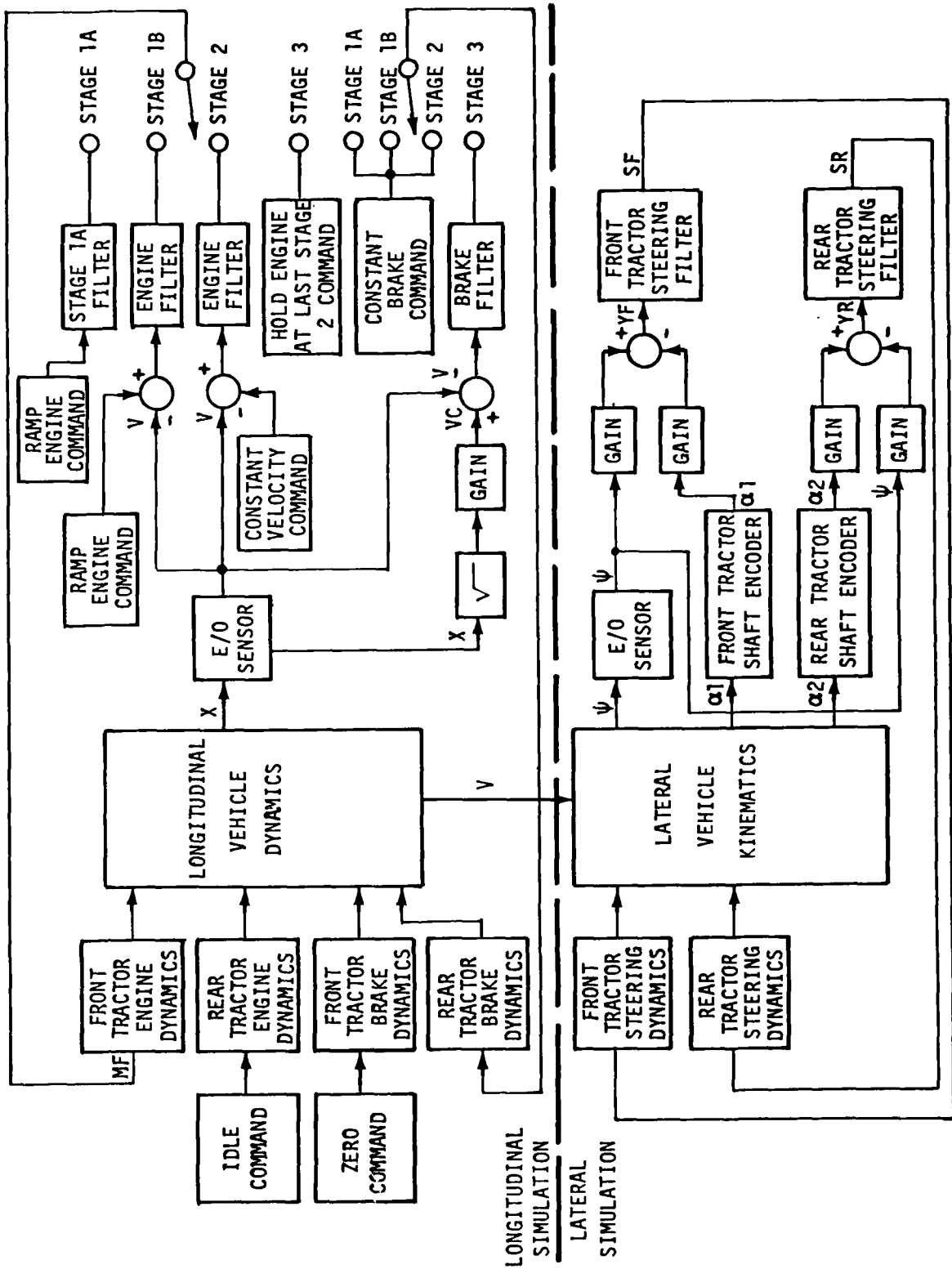

FIGURE 6 MANEUVERABILITY SIMULATION (AUTOMATIC MODE)

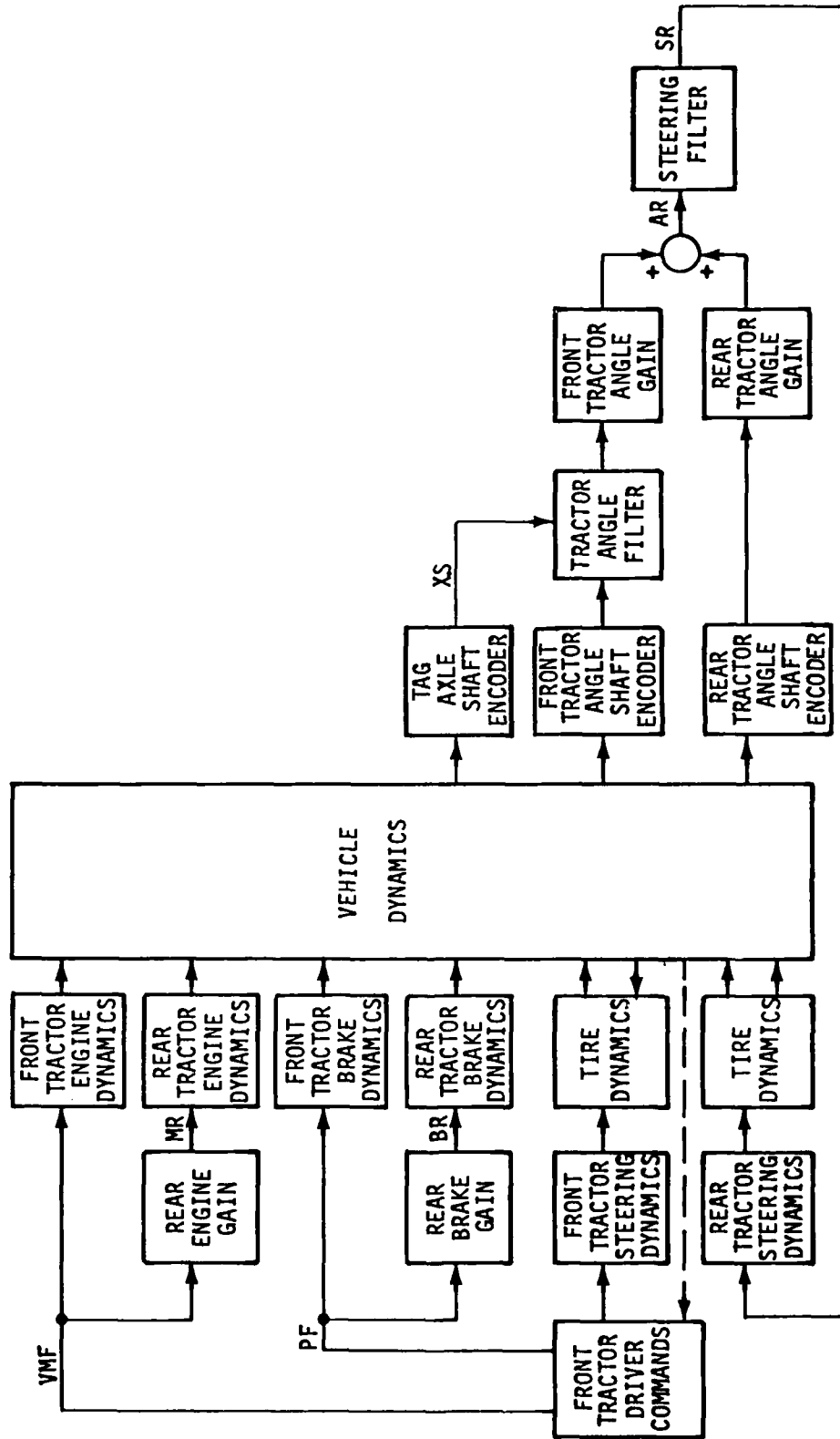

FIGURE 7 ROADABILITY SIMULATION (AUTOMATIC MODE)

- 1) lateral position
- 2) longitudinal position
- 3) frame angle
- 4) front tractor angle
- 5) rear tractor angle

The model is suitable for both longitudinal and lateral simulation. The tire dynamic model generates forces proportional to tire slip angle (References 1, 2, 3). Estimates of tire cornering coefficient (the proportionality constant between tire slip angle and tire side force) were made using empirically derived equations obtained from the literature (Reference 4). Control laws and models of sensors and actuators are included in the model.

The over-the-road computer model was exercised using both time and frequency domain techniques to give well damped performance and adequate tracking for all speeds considered for the test program. The control gains GTR1 and GTR2 were adjusted to give minimal steady state tracking offsets of time simulations on a curve. It was found that for any GTR2 a GTR1 could be found to minimize steady state off tracking. The relation between the two gains is approximately represented by the following equation at slow speeds

$$\text{GTR2} - \text{GTR1} = \frac{2L_1}{L_2} \approx 0.7 \text{ radian/radian}$$

where L_1 distance between the fixed and steered axles on each tractor and L_2 = the distance between the fixed axles of one tractor to the fixed axles of the other. The filter constant, AFLT, was adjusted to give a small transient upon entry to or exit from a curve. A gain margin of at least 6 dB was confirmed for all gains selected. It was found that optimal gain varied as a function of speed. For the test vehicle, two gains were selected, one for high speed and one for low speed. A root locus for the high speed (30 mph) case is shown (dominant poles only) in Figure 8 with the points corresponding to the selected gain indicated. The transfer function of front to rear steering is shown in Figure 9 for a variety of speeds, including both high and low speed cases.

Steady state tracking offset on a curve is related to speed by the following equation

$$\text{tracking offset} = \frac{LmV^2}{24 RC}$$

where L is the distance between tracking offset points, m is mass, V is speed, R is radius of road curvature, and C is the time cornering coefficient.

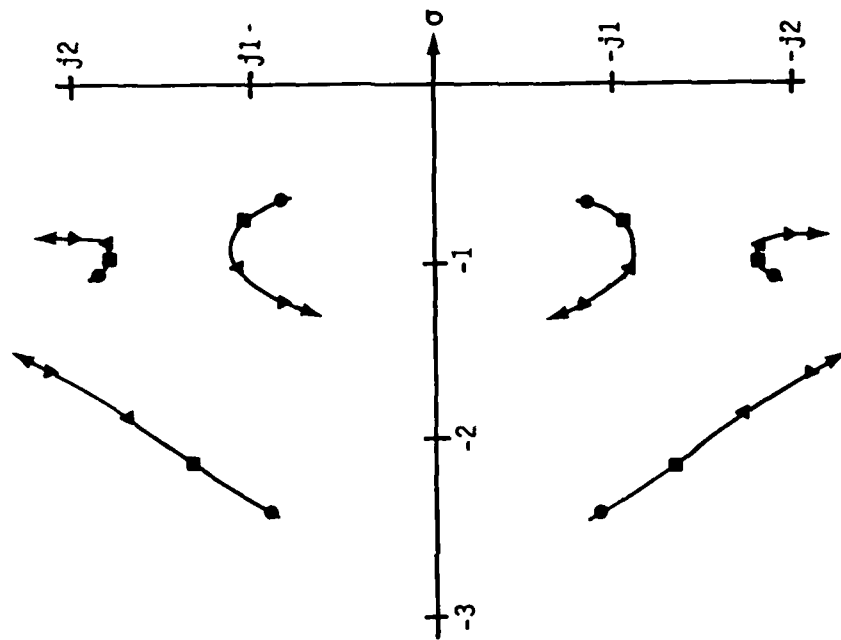

SYMBOL	GTR1	GTR2
●	0.16	0.8
■	0.4	1.0*
▲	0.6	1.2
▼	0.75	1.5

* SELECTED HIGH SPEED GAIN

FIGURE 8 ROOT LOCUS OF TRACTOR ANGLE GAIN VARIATIONS (30 MPH).

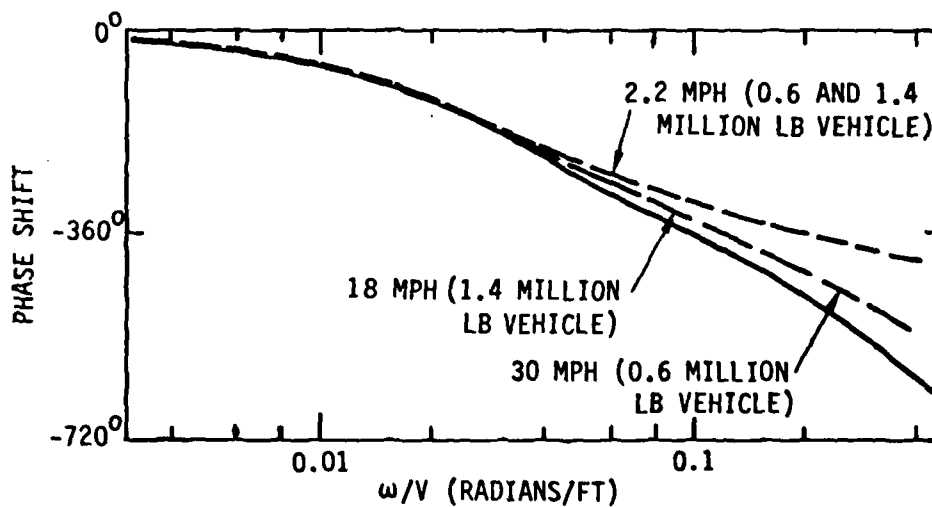
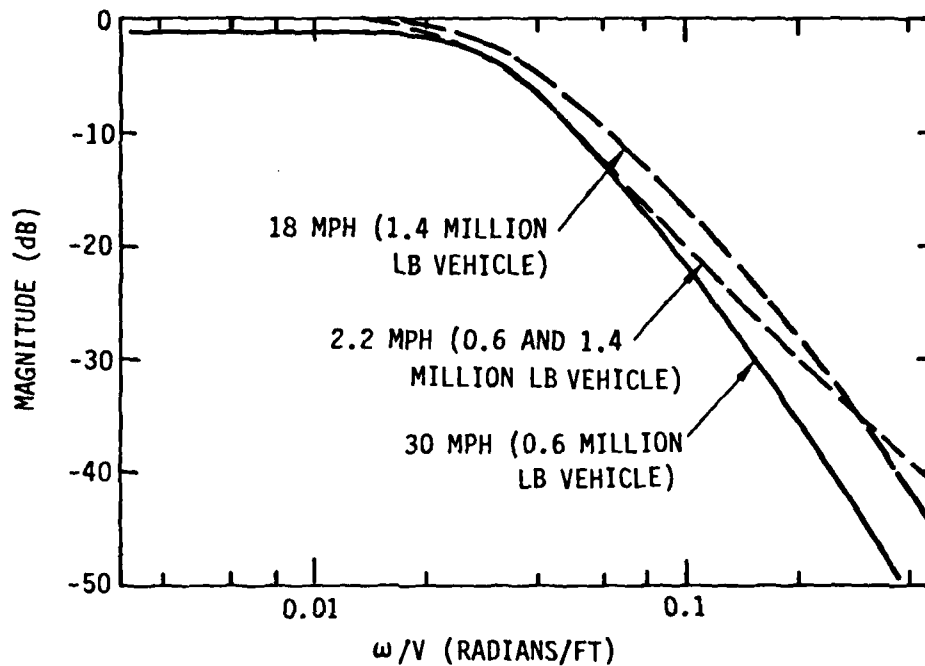

FIGURE 9 BODE MAGNITUDE AND PHASE PLOT OF TRANSFER FUNCTION FROM FRONT STEERING ANGLE TO REAR STEERING ANGLE.

TEST RESULTS

Initial over-the-road testing was started in December 1979 at the MX Engineering Test Bed (ETB) located inside the Nevada Test Site (Department of Energy) near Lathrop Wells, Nevada. Primary data acquired during testing were 22 channels of measurements from the command and control IFC, and "passive" measurements of the TE's position on the road surface.

Maneuverability tests, conducted in three modes of operation (automatic, semiautomatic, and manual) for two vehicle weight configurations (heavy and intermediate) demonstrated that the TE can be positioned accurately at a vertical shelter provided sufficiently accurate position information is available. Final position accuracies are summarized in Figure 10 for all heavy weight runs. Before each test the vehicle was positioned 250 feet from the shelter with the front tractor within 1 foot of the approach road centerline and the rear tractor within 1 foot offset of the front tractor. During the tests the vehicle approached and was positioned over the shelter from this initial position. Positioning accuracy statistics for the TE are summarized in Table I.

Very accurate lateral positioning was obtained for all automatic and semiautomatic runs with only one run greater than 1 inch. For the heavy weight configuration worst case lateral positioning was 0.2 in for both automatic and semi-automatic runs. Little difference was observed between the lateral accuracies recorded for automatic and semi-automatic modes. The slightly worse performance of semi-automatic mode lateral positioning for intermediate weight is probably the result of slightly worse control system calibration during several of these runs, rather than due to inherent inaccuracy of the semi-automatic mode steering. The intermediate weight runs were less accurate than the heavy weight runs. The cause of this difference was principally a malfunctioning front steering shaft encoder that existed throughout most of the intermediate weight runs and was detected and replaced prior to running in the heavy weight configuration.

Lateral positioning in manual mode was somewhat worse than in automatic and semi-automatic mode, but was still quite accurate. The reduced accuracy is explained by the relatively poor lateral position information (verbal cues) available to the drivers. It is noted that there was improvement in performance in the heavy weight runs compared with the earlier intermediate weight runs presumably resulting from greater experience. It is expected that improved manual lateral positioning accuracy could be obtained with improved driver and observer training and/or improved procedures.

Longitudinal accuracies in automatic and semi-automatic modes for the intermediate weight runs were dominated by ranging inaccuracies of the electro-optical (E-0) sensor yielding rather poor results. The ranging accuracy of the E-0 system was improved prior to making runs in the heavy weight configuration resulting in improved performance during the heavy weight runs. It is believed that further improvement in performance could be made with further improvement of ranging accuracy.

Longitudinal positioning accuracy in the manual mode, in both heavy and intermediate weight configurations, were better than automatic and semi-automatic positioning. The explanation for this greater accuracy is that the observers under the TE could verbally provide the drivers more accurate range information than the E-0 sensor provided.

Angular orientation of the TE was in all cases considerably more accurate than the design goal. It is expected that even greater accuracy could be achieved in automatic and semi-automatic modes if the lateral control system is more accurately calibrated for angular accuracy.

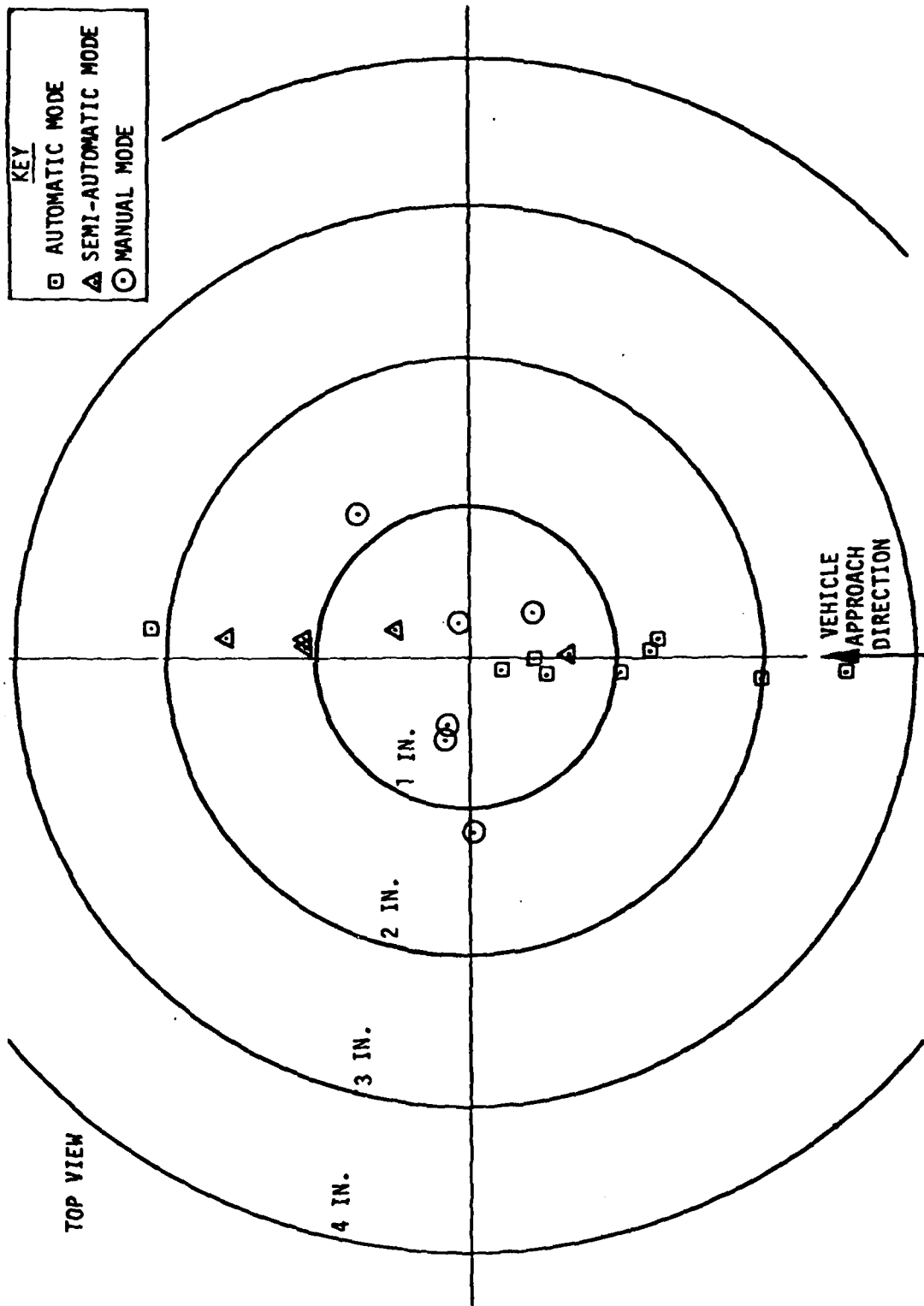

FIGURE 10 NEAR SHELTER POSITIONING ACCURACY

Table I. Positioning Accuracies

WEIGHT	MODE	NO. OF RUNS		LONGITUDINAL OFFSET (in)	LATERAL OFFSET (in)	ANGULAR OFFSET (deg)
Intermediate	Automatic	5	Mean	+15.9	-0.0	+0.13
			Std Dev	17.0	0.4	0.42
	Semi-Automatic	5	Mean	+11.3	-0.3	+0.30
			Std Dev	20.0	0.5	0.15
	Manual	5	Mean	+0.3	+0.3	+0.04
			Std Dev	0.7	1.1	0.12
Heavy	Automatic	9	Mean	-0.8	0.0	+0.49
			Std Dev	1.3	0.1	0.10
	Semi-Automatic	6	Mean	+1.3	-0.1	+0.58
			Std Dev	1.6	0.1	0.01
	Manual	6	Mean	+0.1	-0.3	+0.36
			Std Dev	0.4	0.7	0.33

Roadability tests demonstrated the TE can be accurately controlled for over-the-road travel in a straightaway and 380-foot minimum turning radius. A total of 60 runs were made around the 2.9 mile test track at intermediate and heavy weight configurations at speeds up to 16 MPH.

Computed extra road width (3σ) needed to allow the TE to travel over-the-road was determined to be almost entirely due to front tractor driver performance, with relatively little additional road width required to provide for off tracking of the rear tractor. The required extra road width is 5.25 feet, as summarized in Figure 11.

During the tests, the TE was driven in the clockwise direction around the teardrop-shaped track as shown in Figure 12. Data were acquired while traversing the following five test stations:

1. Station 1 - Entry to the 1700 ft radius curve
2. Station 2 - Exit of the 1700 ft radius curve
3. Station 3 - Straightaway
4. Station 4 - Entry into the 380 foot radius curve
5. Station 5 - Exit to the 380 foot radius curve.

The matrix of runs that were performed is presented in Table II.

Under the hitch of the front tractor was a paint spray device which laid down a yellow line on the road surface. Under the hitch of the rear tractor was a paint spray device which laid down a white line. Lateral difference between the centers of the two lines was defined as the tracking error. A positive tracking error is defined as the rear tractor being right of the front tractor, or inside of it on a curve.

Table III presents the front tractor range, the rear tractor tracking and the extra road width needed for the TE to traverse the test track. Front tractor range was obtained by adding the average offset from the centerline with three times the offset standard deviation. Rear tractor tracking was obtained by adding the average tracking error with three times the error standard deviation. Extra road width needed was obtained by root-sum-squaring the front tractor range and the rear tractor tracking. Road width required for the TE is a function of both the front driver positioning and tracking by the rear tractor in addition to geometrical considerations. The extra road width necessary for the TE is 63 inches based on these limited roadability tests. Additional road width, not included in the above estimates, will be required to accommodate all weather operation vehicle tolerances and road construction tolerances.

COMPARISON OF SIMULATION AND RESULTS

Offsets of the front and rear tractors from the pad centerline, during near shelter approach are shown in Figure 13. Graphs from representative computer simulation predictions are presented for comparison purposes. In general, all test runs show a transient at the start of the runs and a fan-out at the end of the runs. Both effects were predicted by computer simulations. Pad offsets were well within the range of values expected based on computer simulations.

Velocity during near shelter approach is graphed for representative test runs in Figure 14 together with computer predictions. Velocity measurements were made with the electro-optical sensor, which generated velocity by differentiating and filtering range.

Figure 15 shows the mean steady state offset around the 380 ft radius curve at intermediate weight. The data has been adjusted so that the tracking

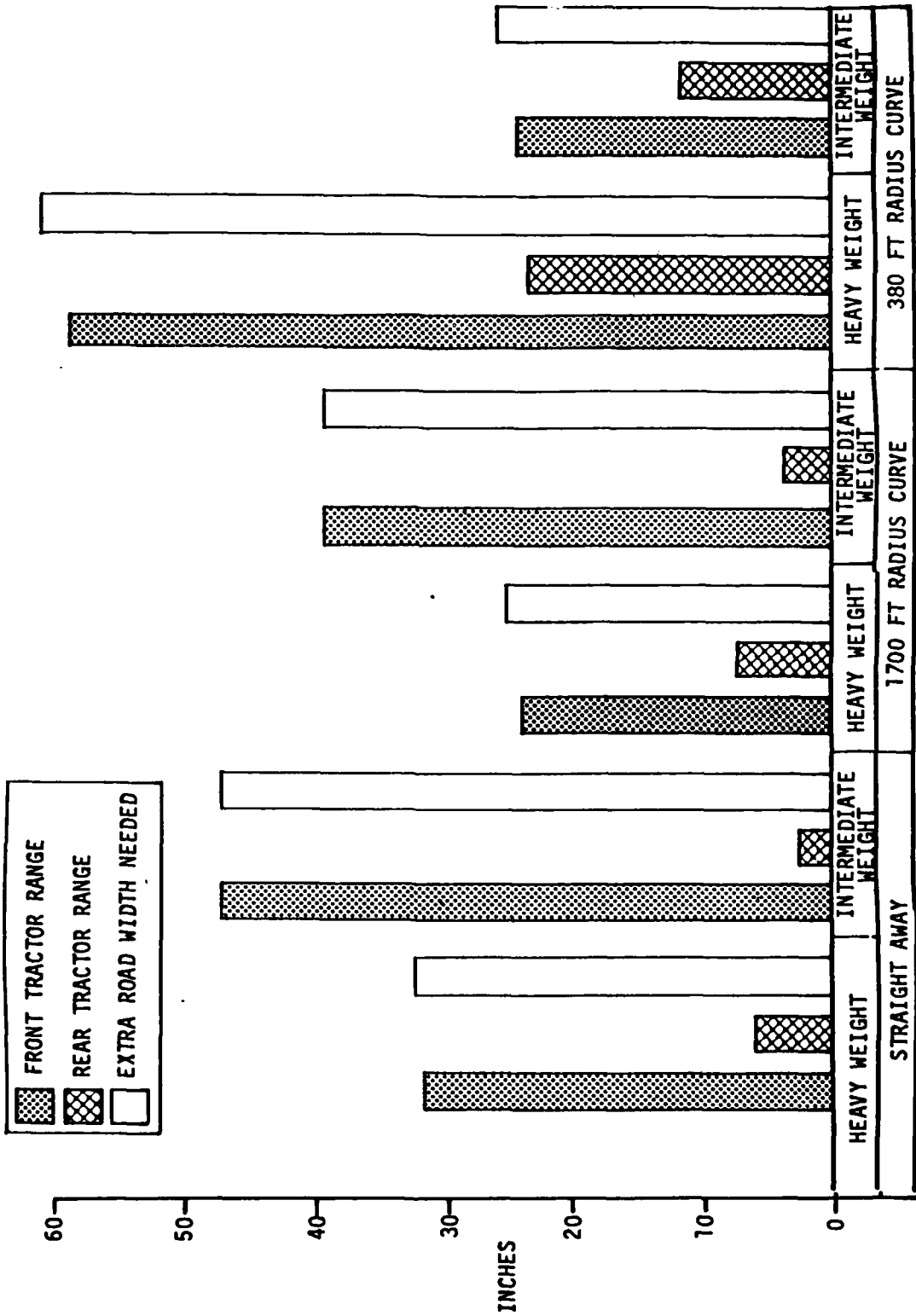

FIGURE 11 ROADABILITY PERFORMANCE - AUTOMATIC MODE

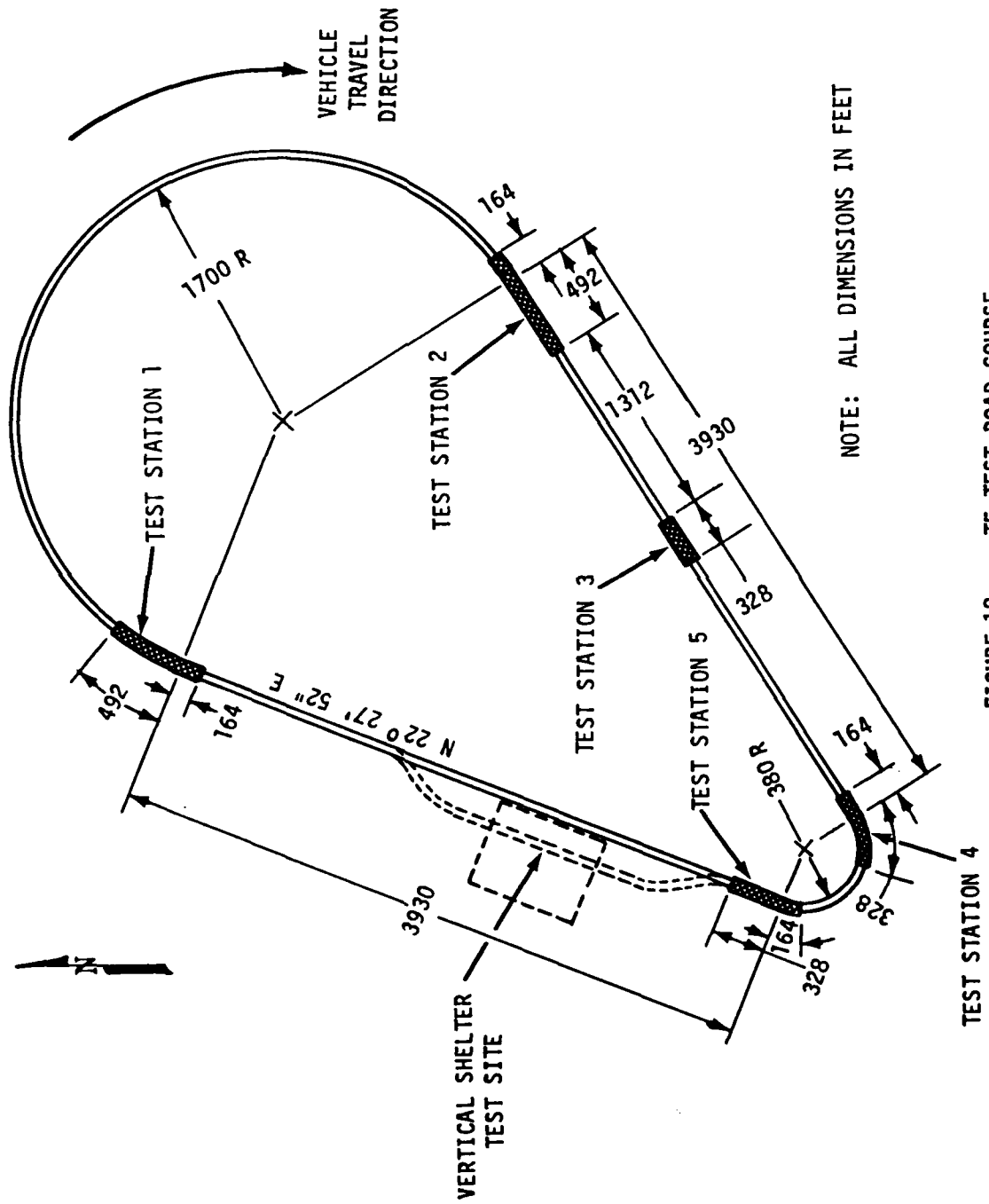

FIGURE 12 TE TEST ROAD COURSE

TABLE II. TE ROADABILITY TEST MATRIX

VEHICLE WEIGHT		CONTROL		DRIVERS	VELOCITY mph
INTERMEDIATE	HEAVY	AUTOMATIC	SEMI- AUTOMATIC		
	X	X		1	3.0
	X	X		1	6.0
	X	X		1	9.0
	X	X		1	12.0
	X		X	2	5.0
	X		X	2	10.0
X		X		1	4.0
X		X		1	8.0
X		X		1	12.0
X		X		1	16.0
X			X	2	5.0
X			X	2	10.0

TABLE III. ROADABILITY PERFORMANCE

	AUTOMATIC			SEMI-AUTOMATIC		
	FRONT TRACTOR RANGE (in)	REAR TRACTOR TRACKING (in)	EXTRA ROAD WIDTH NEEDED (in)	FRONT TRACTOR RANGE (in)	REAR TRACTOR TRACKING (in)	EXTRA ROAD WIDTH NEEDED (in)
<u>HEAVY WEIGHT</u>						
STRAIGHT ROAD	31.3	5.5	31.8	28.6	9.0	30.0
1700 ft RADIUS	24.0	6.9	24.9	38.3	21.2	43.8
380 ft RADIUS	59.2	22.2	63.3	38.4	39.0	54.7
<u>INTERMEDIATE WEIGHT</u>						
STRAIGHT ROAD	45.3	2.2	45.4	27.6*	5.4	28.1*
1700 ft RADIUS	38.9	4.0	39.1	24.1	5.5	24.8
380 ft RADIUS	24.8	10.7	27.1	32.2*	10.4	33.8*

*Front tractor purposely driven left of the "centerline."

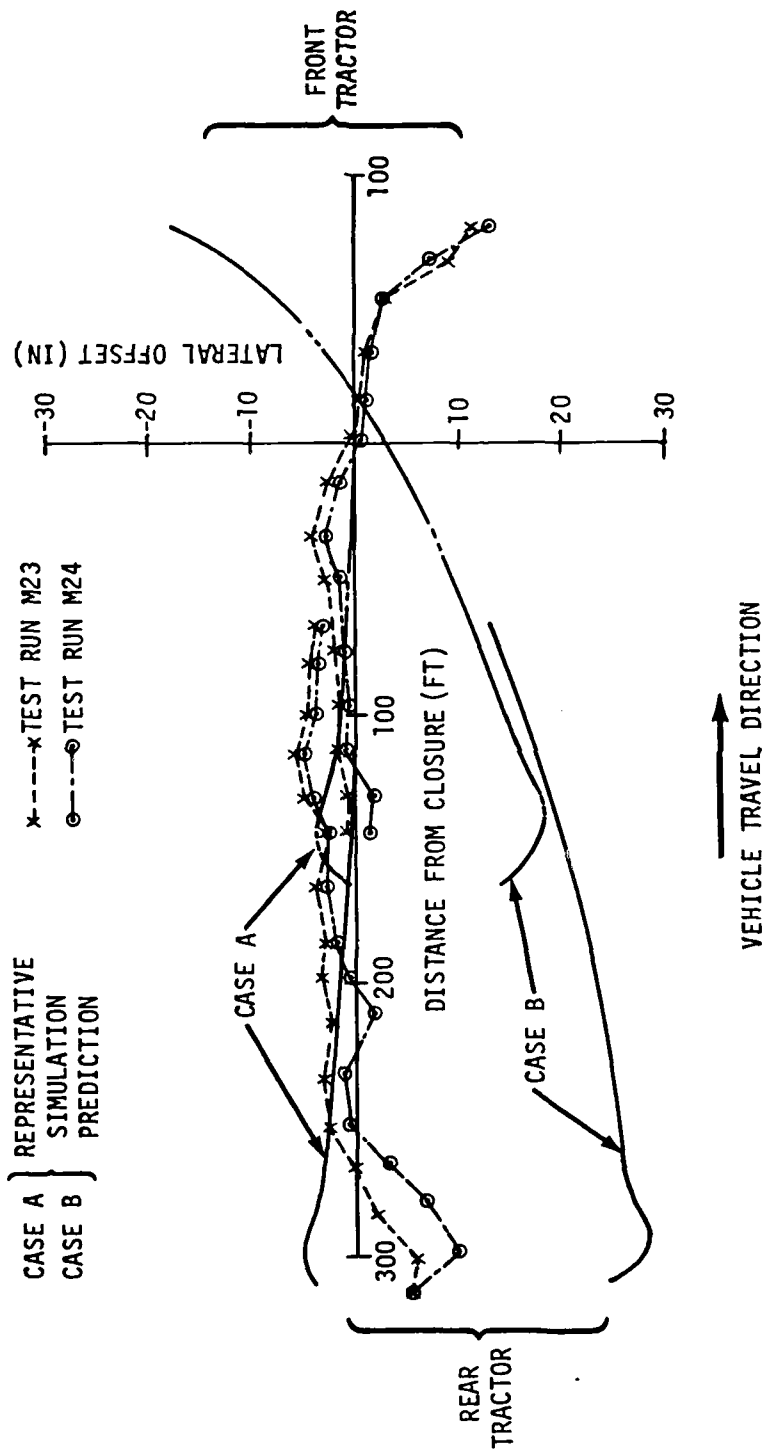

FIGURE 13 TRACTOR OFFSET FROM PAD CENTERLINE - HEAVY WEIGHT

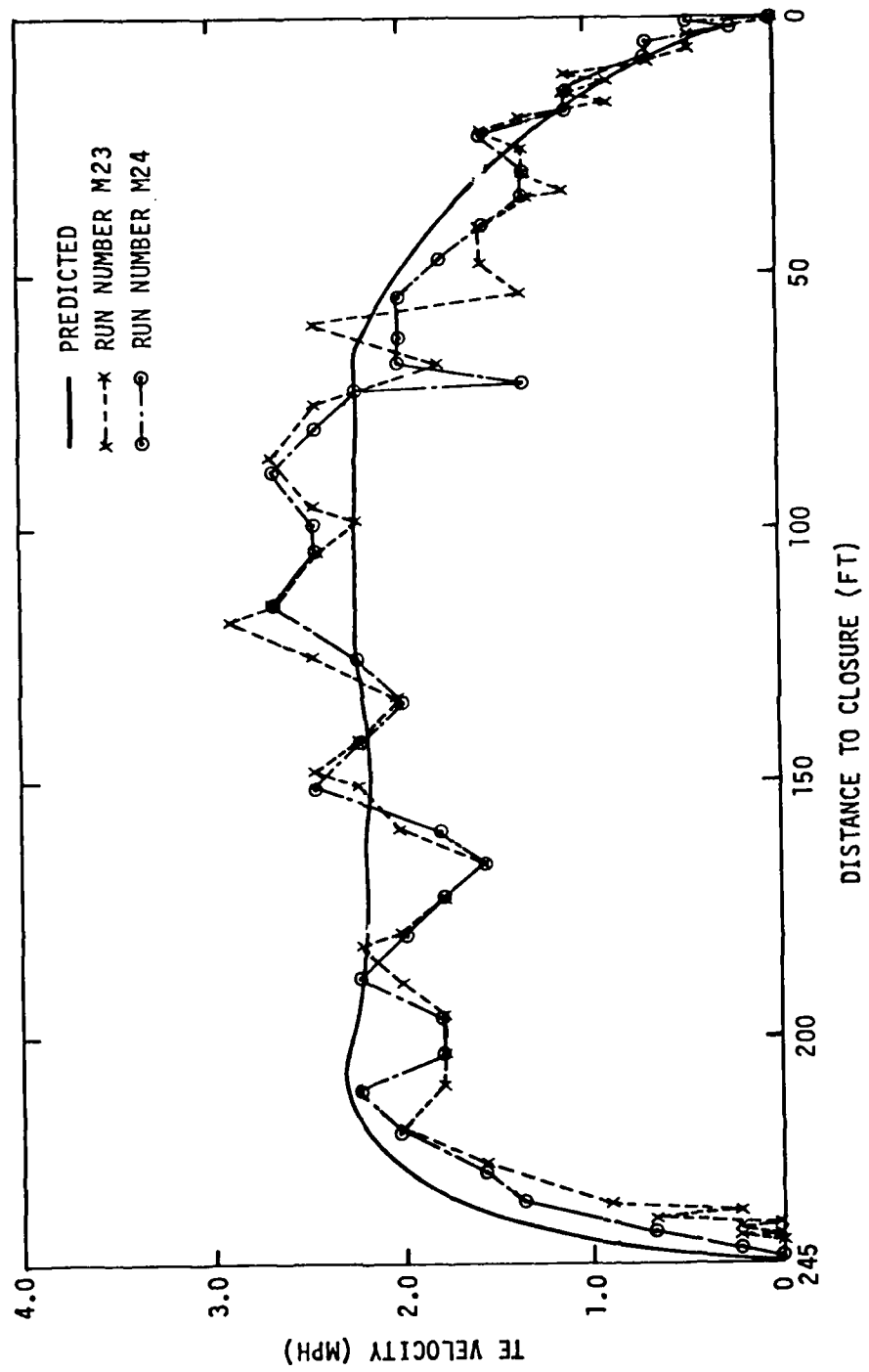
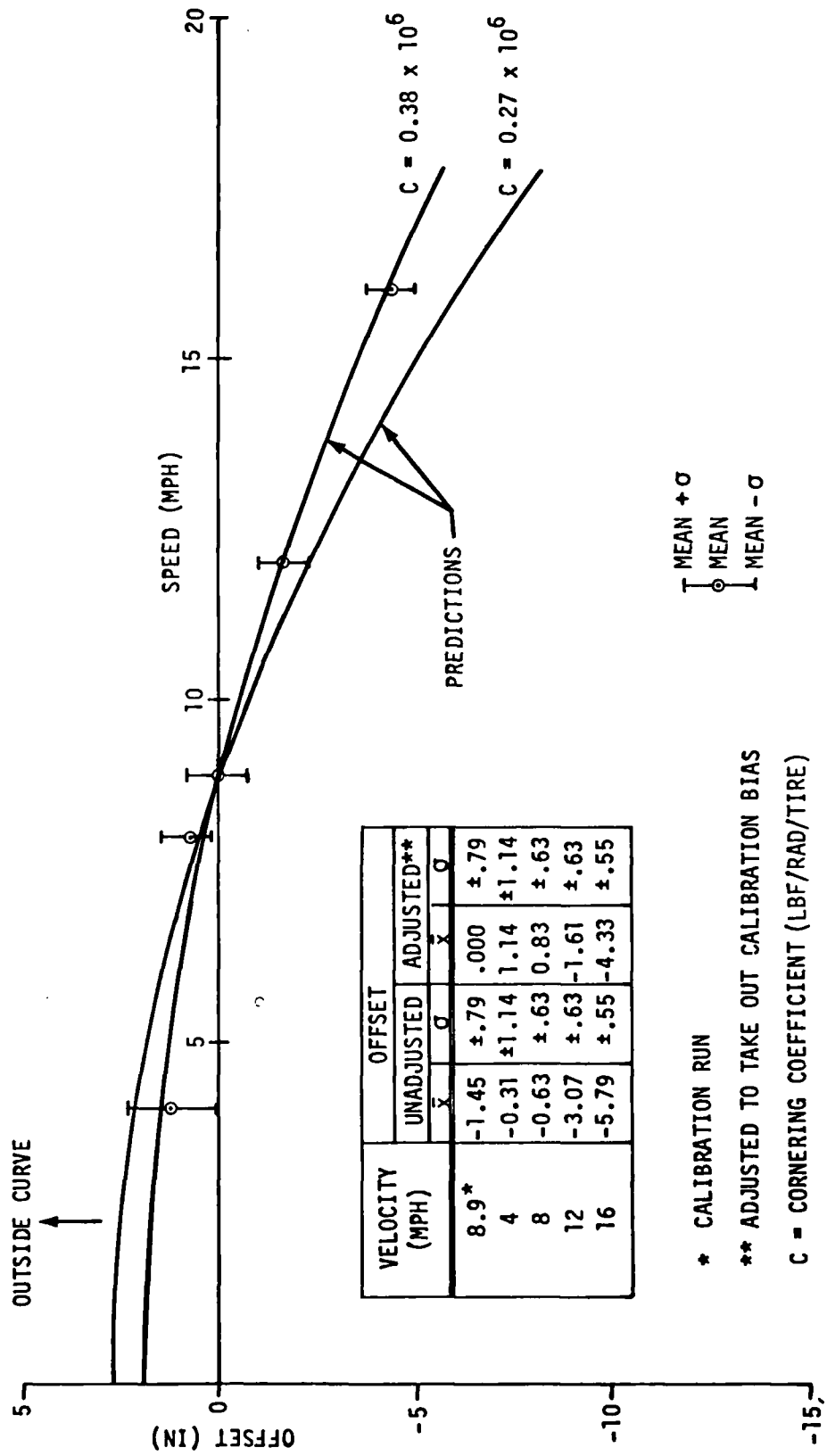

FIGURE 14 AUTOMATIC MODE VELOCITY PROFILE - HEAVY WEIGHT



* CALIBRATION RUN

** ADJUSTED TO TAKE OUT CALIBRATION BIAS

C = CORNERING COEFFICIENT (LBF/RAD/TIRE)

FIGURE 15 MEAN STEADY STATE OFFSET AROUND 380 FT RADIUS CURVE - INTERMEDIATE WEIGHT

offset is zero at 8.9 MPH. The predicted cornering coefficient was 0.27×10^6 lbf/rad/tire, but a cornering coefficient of 0.38×10^6 lbf/rad/tire fits the data better.

Dynamic tracking performance of the TE around the 380 foot radius curve compared to predictions is shown in Figure 16 for the intermediate weight configuration for 8 mph velocity. Steady-state performance in the curve is well within the bounds of the prediction.

CONCLUSIONS

1. All maneuverability and roadability test objectives for the heavy and intermediate weight configurations have been met.
2. Large rubber-tired ground vehicles that will be deployed as part of the MX program can be positioned accurately at shelters and can be controlled with sufficient accuracy to minimize road costs.
3. The guidance and control system performed close to expectations. Refinements are still required to accommodate all weather operation and improved reliability.
4. Experience gained from the TE will serve as a basis for further MX ground vehicle control system design for any of the MX basing modes currently being considered.

REFERENCES

1. Ellis, J. R., Vehicle Dynamics, Business Books Limited, London, 1969.
2. Taborek, Taroslav J., Mechanics of Vehicles, Penton Publishing Co., Cleveland, Ohio, 1957.
3. Wong, J. Y., Theory of Ground Vehicles, John Wiley & Sons, New York, 1978.
4. Smiley, R. F. and Horne, W. B., "Mechanical Properties of Penumatic Tires With Special Reference to Modern Aircraft Tires," NASA TR R-64, 1960.

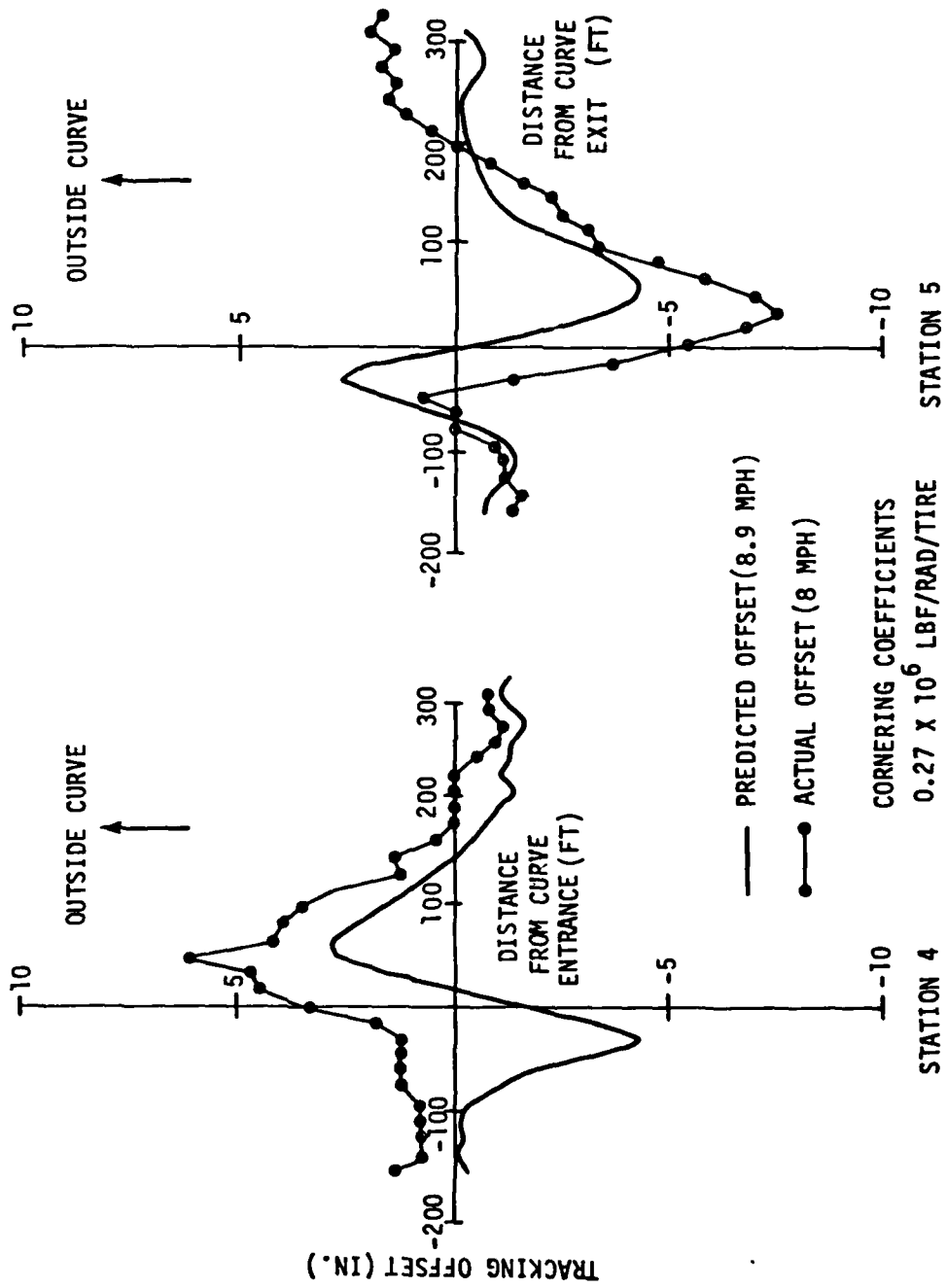

STATION 4 STATION 5
 TRACKING OFFSET (IN.)
 DISTANCE FROM CURVE ENTRANCE (FT)
 DISTANCE FROM CURVE EXIT (FT)
 OUTSIDE CURVE
 — PREDICTED OFFSET (8.9 MPH)
 ● ACTUAL OFFSET (8 MPH)
 CORNERING COEFFICIENTS
 0.27×10^6 LBF/RAD/TIRE

FIGURE 16 TRACKING OFFSET AROUND 380 FT RADIUS CURVE - INTERMEDIATE WEIGHT