





## FOREWORD

With the advent of more sophisticated tactical and surveillance weapon systems, the Navy has the need to improve system performance prediction. Critical to this need are definitive models of the ocean floor and subbottom as a transmission media that refracts, diffracts, diffuses and dissipates, as well as reflects, acoustic energy. A multi-channel array and low frequency sound source system towed near the bottom in the deep ocean can provide the capability to determine the detailed geophysical character of the sea floor and subbottom structure and thus provide the high resolution geoacoustic input parameters required for modeling. This technical note provides the reader with an overview of a deep-towed system development to meet this critical Navy need. Slide material with text used in a presentation to management reviewing program objectives, progress, and plans is presented.

## ABSTRACT

A program has been initiated to develop a deep-towed system consisting of a low frequency sound source, hydrophone array, communication and data recording system, and data processing capability for measuring in the deep ocean (6000 m depth) the detailed spatial variability of the geological, geophysical, and geoacoustic parameters of the ocean floor and first 500 m of subbottom structure. This high resolution data set will allow computing definitive geoacoustic model input parameters for performance prediction of naval fleet systems with acoustic bottom interaction. The technology developments of this program will provide both the Navy and the marine science and technology communities with a new deep-ocean measurement capability.

Performance studies show an order of magnitude improvement in geoacoustic parameter determination and spatial resolution for the deep-towed system over conventional surface-towed systems operating in deep water. System configuration trade-offs, optimized for compressional wave speed measurement precision, have been performed utilizing a statistical error approach. This approach provides quantitative error prediction for such varying system parameters as array length, offset (sound source to array distance), group spacing (hydrophone separation), and system tow altitude based on statistical variance of reflection energy arrival times.

Hardware parameter characterization studies have identified technology development areas and critical system parameters required to meet the scientific deep-ocean measurement goals. A Helmholtz resonator transducer and a hydroacoustic impulse device have been identified as two approaches for sound generation in a deep-towed configuration. The more acoustically optimum impulse device has a projected acoustic spectral level of  $172 \text{ dB}/\mu\text{pa} \cdot \text{sec}^2/\text{Hz}$  over 200 Hz to 700 Hz band, and a peak source level of  $224 \text{ dB}/\mu\text{pa}$  @ 1 m. The initial design parameters for the deep-towed array are 1000 m long, 40 m offset, 40 m group spacing, and 25 hydrophone channels. Communications with the towed system will employ a digital time division multiplex approach with 27 high data rate acoustic channels and 23 low data rate engineering sensor channels. The navigation suit will employ a deep-towed doppler navigator and a ship-interrogated short base line navigation system. This suit allows firing the sound source at fixed distances along track and positioning the sound source/array relative to the tow ship. A unique data processing approach to extract the geoacoustic parameters employing the nonhyperbolic moveout of the deep-towed data set has been initially tested through performance prediction simulations.

Hardware fabrication will be initiated in late 1980 with extensive subsystem testing throughout the development cycle. A total system test emphasizing definitive performance evaluation is planned for 1984.

This technical note presents slide material with text that was used in a presentation to management for reviewing program objectives, projected system scientific and technical capabilities, system performance predictions, basic hardware characteristics, data processing requirements, and plans outlining total system hardware development.

### ACKNOWLEDGEMENTS

The authors are grateful for those personnel in NORDA's Environmental Requirements and Program Analysis Group and the Ocean Science and Technology Laboratory's Numerical Modeling, Ocean Acoustics, and Sea Floor Divisions who have contributed since the program was initiated in 1978, by providing insights into the Navy need and system scientific applications. We are especially grateful to our co-workers in the Ocean Technology Division for their technical contributions.

Special thanks are extended to Ms. Melanie Carroll, Ms. Shirley Laursen, and Ms. Lonnia Martin for typing the manuscript.

Thanks also go to NORDA's Technical Information Branch for preparing the illustrations used in the manuscript.

<b>Accession For</b>	
NTIS GRA&I	<input checked="" type="checkbox"/>
ERIC TAB	<input type="checkbox"/>
Unannounced	<input type="checkbox"/>
Justification	
By _____	
Distribution/	
<b>Availability Codes</b>	
Dist	Avail and/or Special
<b>A</b>	

## ILLUSTRATIONS

	Page
Figure 1. Pictorial of Deep-Towed System Configuration	2
Figure 2. Development Program Objective	4
Figure 3. Program History	6
Figure 4. Publications and Presentations	8
Figure 5. Program-Sponsored Studies	10
Figure 6. Navy Need	12
Figure 7. DTAGS Scientific Capability	14
Figure 8. DTAGS Technology Provides	16
Figure 9. DTAGS Scientific Capability Review	18
Figure 10. Fundamental Advantage of a Deep-Towed System	20
Figure 11. System Comparison: Deep-Towed Versus Conventional Surface-Towed	22
Figure 12. System Comparison: Deep-Towed Versus Surface Source/Deep Array	24
Figure 13. System Comparison: Deep-Towed Versus Long Surface-Towed Array	26
Figure 14. Performance Trade-off: Array Length	28
Figure 15. Geoacoustic Parameter Measurement	30
Figure 16. Acoustic Footprint	32
Figure 17. Additional Scientific Capabilities	34
Figure 18. DTAGS Scientific Capability Provides	36
Figure 19. Major Technology Development Areas	38
Figure 20. Deep Sound Source Overview	40
Figure 21. Helmholtz Transducer Pictorial	42
Figure 22. Helmholtz Transducer Specifications	44
Figure 23. Hydroacoustic Impulse Sound Source Pictorial	46
Figure 24. Hydroacoustic Impulse Sound Source Towing Configuration	48

	<b>Page</b>
Figure 25. Hydroacoustic Impulse Sound Source Parameters	50
Figure 26. Hydroacoustic Impulse Sound Source Acoustic Spectrum	52
Figure 27. Deep-Towed Array	54
Figure 28. Projected Dynamic Response: Fish/Array	56
Figure 29. Communication Requirements	58
Figure 30. Coaxial Tow Cable Transfer Function	60
Figure 31. Navigation Requirements	62
Figure 32. Data Processing Requirements	64
Figure 33. Deep-Towed Geophysical Array System Capability Summary	66
Figure 34. Plans: FY81 and FY82	68
Figure 35. Plans: FY83 and FY84	70

**DEEP-TOWED  
GEOPHYSICAL  
ARRAY SYSTEM**



Development Program Review

Figure 1. Pictorial of Deep-Towed System Configuration.

Depicted is the basic configuration for the deep-towed system. A sound source is located within a deep-towed instrumentation package (fish) towed at the head of a multi-channel hydrophone array. This deep-towed system is tethered to a tow ship with a coaxial steel tow cable. The system design goal is a 6000 m operating tow depth with acoustic penetration down to 500 m of subbottom structure. This penetration depth encompasses the most critical sediment section for predicting the performance of naval fleet systems. Although this development effort entails some technical risk, a program has been formulated to minimize these risks. We have examined, through performance prediction analysis and hardware parameter characterization studies, some of the more critical scientific application and technology development areas. The results of these studies plus the future plans for complete system hardware development will be presented in the following figures.

**DEEP-TOWED  
GEOPHYSICAL  
ARRAY SYSTEM**

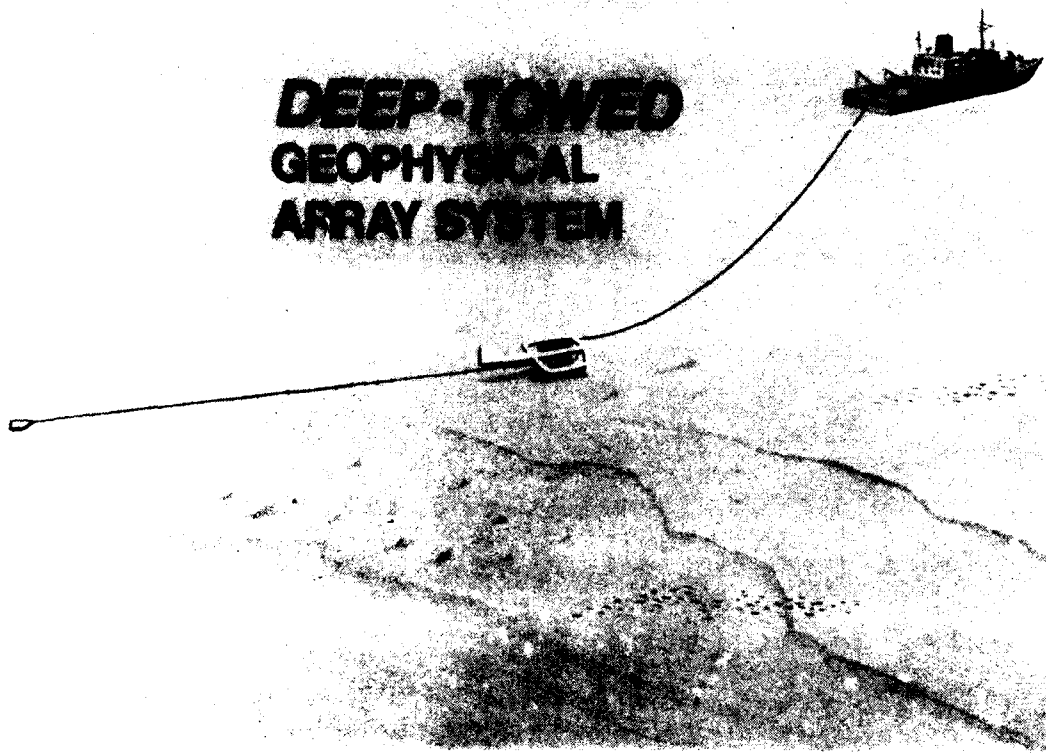

## Figure 2. Development Program Objective

The objective of the program is to develop a deep-towed hydrophone array and sound source system that will provide the capability to quantitatively define in the deep ocean the detailed character of the sea floor and subbottom in the areas of geology, geophysics, and geoacoustics. It will be shown that alternate configurations, such as surface-towed systems, surface sound source with a deep-towed array or even a long surface-towed array, will not provide the detailed character that can be obtained with a deep-towed configuration.

# DEEP-TOWED GEOPHYSICAL ARRAY SYSTEM

## OBJECTIVE

### SCIENTIFIC

- Provide a Detailed Geological, Geophysical, and Geoacoustical Description of the Sea Floor and Subbottom

### TECHNICAL

- Develop the Technology for Fabricating, Operating, and Processing Data From a Deep-Towed Sound Source/Hydrophone Array System

### Figure 3. Program History

The development effort was initiated in late FY78, and progress to date has been primarily in the area of system performance prediction and identifying major system component characteristics. Also two sea tests have been performed; the first was towing a 600 m long array to a depth of 2000 m, which provided an insight into some of the operational problems that will be encountered when towing the actual completed system. Second, tests have been performed to determine the electromechanical characteristics of potential tow cables.

# DEEP-TOWED GEOPHYSICAL ARRAY SYSTEM

PROGRAM INITIATED - LATE FY78

## PROGRESS

- System Performance Prediction Studies
- Hardware Characteristic Definition
- Sea Test
  - Deep-Tow Array - Model Validation
  - Coaxial Steel Tow Cable - Assess Electro-Mechanical Characteristics

**Figure 4. Publications and Presentations**

A series of publications (identified here) has also been produced and, in addition, the results of the development effort have been presented at various symposiums and seminars.

# DEEP-TOWED GEOPHYSICAL ARRAY SYSTEM

## PUBLICATIONS

- Fagot, Martin G. and Bruce E. Eckstein (1979), "Deep-Towed Geophysical Array Development Program Progress Report (FY78)", NORDA Technical Note #41, February
- Milburn, D.A. and M.G. Fagot (1979), "The Steady-State Analysis of Candidate Towing Cables for the Deep-Towed Geophysical Array System", NORDA Technical Note #40, March
- Gholson, Norman H. and Martin G. Fagot (1980), "A Moments Approach for Analyzing Geophysical Acoustic Reflection Data", NORDA Report #30, (In Press)
- Gholson, Norman H. and Martin G. Fagot (1980), "Quantative Performance Prediction for a Deep-Towed Geophysical Array System", NORDA Technical Note (Draft)

## PRESENTATIONS

- Deep-Towed Seismic System Design, 1st SEG-US Navy Symposium, Bay St. Louis, MS., 18 August 1978
- Deep-Towed Seismic System Design, 48th Annual International Meeting of the Society of Exploration Geophysicists, San Francisco, 30 October 1978
- Deep-Towed Seismic Profiling System, Electronics & Aerospace Systems Conference, Arlington, Va., 10 October 1979
- Deep-Towed Geophysical Array System Program, Naval Oceanographic Office Seminar, 4 March 1980
- Estimating Deep Ocean Subbottom Sound Velocity from Seismic Reflection Data, 2nd SEG-US Navy Symposium, NSTL Station, MS., 17 March 1980
- A Deep-Towed Geophysical Array System, 2nd SEG-US Navy Symposium, NSTL Station, MS., 18 March 1980

**Figure 5. Program Sponsored Studies**

A series of studies in critical areas have been sponsored by the program and some of the results will be presented.

# DEEP-TOWED GEOPHYSICAL ARRAY SYSTEM

## PROGRAM SPONSORED STUDIES

- Groves, I. D. (1978), Deep-Tow Low Frequency Sound Source Technology Assessment ,  
NRL/USRD Ref. 8277:AMY:dab, 16 June (Report)
- Stoffa, Paul (May, 1979), Design Criteria for a Deep-Towed Source and Multi-Channel  
Array, Chute Stoffa, Inc., Report
- Stoffa, Paul (Sep 1979), Data Processing Requirement for a Deep-Towed Source and Multi-  
Channel Array, Chute Stoffa, Inc., Report
- Huff, C. M. (1979), Preliminary Design of a Geophysical Array System Towed Vehicle,  
NCSC Report, September
- Hydroacoustics, Inc. (1979), Design Study of Hydro-Acoustic Impulse Source for Deep  
Towing, Report #HA 132-79, October
- Ottsen, H. (1979), Some Preliminary Results of the Deep-Towed Geophysical System,  
Western Instrument Corporation Letter Report, November

**Figure 6. Navy Need**

The basic need being addressed by this development is to provide high resolution geoacoustic data of the sea floor and subbottom structure. This will allow performance prediction of naval systems when acoustic bottom interaction is prominent.

# NAVY NEED

## PERFORMANCE PREDICTION FOR NAVAL SYSTEMS WITH ACOUSTIC BOTTOM INTERACTION

### SPECIFICALLY

APPROPRIATE SEA FLOOR AND SUBBOTTOM ACOUSTIC DESCRIPTION  
TO INCLUDE EFFECTS ON PROPAGATING SOUND FIELDS

- Bottom Loss Models
- Geoacoustic Models

### Figure 7. DTAGS Scientific Capability

The prime scientific area being addressed with the Deep-Towed Geophysical Array System, designated DTAGS, is the ability to reduce the geoacoustic parameter measurement uncertainty by providing a system with a high resolution measure of basic input data for determining the geoacoustic character of the sea floor and subbottom. The system will provide a better definition of the underlying geology, thus allowing prediction of the influence of geology on the geoacoustic parameters. In addition, the system will provide a higher resolution description of the sea floor and the subbottom layering for assessing their effects on signal coherence.

## **DTAGS SCIENTIFIC CAPABILITY**

- **REDUCE GEOACOUSTIC PARAMETER UNCERTAINTY THROUGH HIGH SPATIAL RESOLUTION MEASURE OF BASIC DATA**
- **PROVIDE BETTER DEFINITION OF UNDERLYING GEOLOGY FOR PREDICTING INFLUENCE ON GEOACOUSTIC PARAMETERS**
- **PROVIDE A HIGH RESOLUTION DESCRIPTION OF THE SEA FLOOR CHARACTER AND SUBBOTTOM LAYERING TO ASSESS THEIR EFFECT ON COHERENCE**

### Figure 8. DTAGS Technology Provides

In addition to the scientific capability, the Deep-Towed Geophysical Array System program will provide new deep-ocean technology to include: performance characterization in the areas identified on the figure, plus a deep-towed low frequency sound source that has applications in the areas of oceanography, geophysics, acoustics, and a deep-towed array which can be deployed in any water depth. The optimum sound approach source, which will be reviewed later, has a projected bandwidth of 100 to 1000 Hz. Although the prime frequency band for the geophysical application is from 200 to 700 Hz, this broadband source capability will provide many other general applications. In addition, the towed array is also optimized for higher active acoustic frequency range, but will have passive listening capability in a lower frequency range to support acoustic propagation and noise experiments.

## **DTAGS TECHNOLOGY PROVIDES A:**

### **DEEP TOW SYSTEM PERFORMANCE CHARACTERIZATION IN AREAS OF**

- Motion Prediction
- Depth Control
- Deployment/Retrieval
- Communication
- Navigation

### **DEEP TOW LOW FREQUENCY SOUND SOURCE CAPABILITY**

- General Tool for Oceanographic, Geophysical, and Acoustic Research (50-1000Hz)
- Precedent for Lower Frequency Designs

### **DEEP TOW HYDROPHONE ARRAY**

- Deployable Any Depth in Water Column
- Passive Listening
- Support Acoustic Propagation and Noise Experiments

**Figure 9. DTAGS Scientific Capability Review**

The improved scientific capability provided by the ability to acquire a high-resolution data set with a deep-towed configuration is evident from the results of a system performance prediction analysis. The results of some of these analyses are now reviewed.

**DTAGS**  
**SCIENTIFIC CAPABILITY**

### Figure 10. Fundamental Advantage of a Deep-Towed System

The fundamental advantage of a deep-towed system over a surface-towed system for computing the most critical geoaoustic parameter, layer compressional wave speed, is discussed.

The first diagram shows the basic configuration of a seismic profiling system, whether a deep-towed or surface-towed system, with the only difference being the altitude of the tow. The source is at the head of an array containing hydrophones which receive reflected energy from the sea floor and subbottom layers.

Next is a plot to the time (T) required for energy radiated from the source to travel from the source to a reflecting interface and be received at the hydrophone against the horizontal distance (X) from the source to each hydrophone position. Each trace represents the energy received by the hydrophone positioned at the fixed distance from the source. If a line is drawn through each return for the same interface from trace to trace, a nearly hyperbolic trajectory will result and the intercept at zero distance (source location) is the two-way normal incidence travel time.

This same data can be plotted as  $T^2$  versus  $X^2$ , but the trajectory will now be a straight line where the slope is the inverse of the mean square velocity for the medium between the source and the reflecting interface. This slope information is the fundamental data provided by the system, whether deep-towed or surface-towed, used to compute subbottom layer compressional wave speed.

The last diagram is a plot of this slope information for the subbottom reflector against layer compressional wave speed for a surface-towed system at an altitude of 4500 m and a deep-towed system at an altitude of 100 m. As can be seen, the slope is a strong function of layer compressional wave speed for the deep-towed system and weak function for the surface-towed system. Basically, the thick water column is masking the fundamental data required to determine with high precision the subbottom layer compressional wave speed.

For the range of layer compressional wave speed used in this illustration, there is only a small change in slope for surface-towed system and a large change for the deep-towed system.

This is the underlying reason why the performance comparisons to be shown between conventional systems and approaches will show substantially poorer performance when compared against the deep-towed system.

## FUNDAMENTAL ADVANTAGE OF DEEP-TOWED OVER SURFACE-TOWED SYSTEM FOR MEASURING SUBBOTTOM COMPRESSIONAL WAVE SPEED

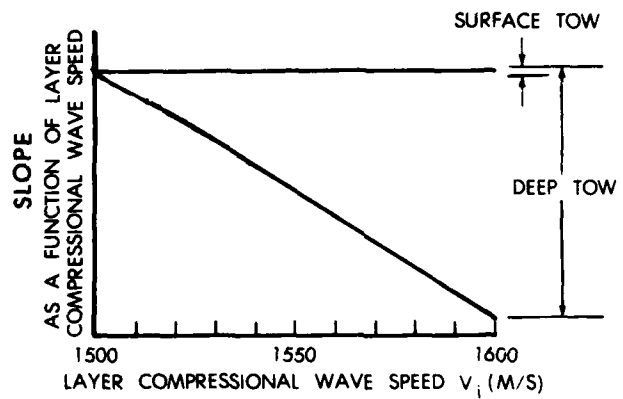
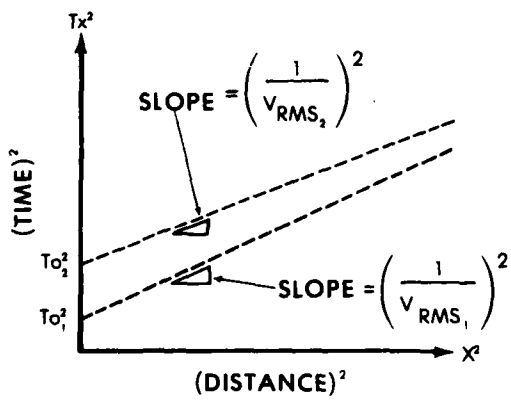
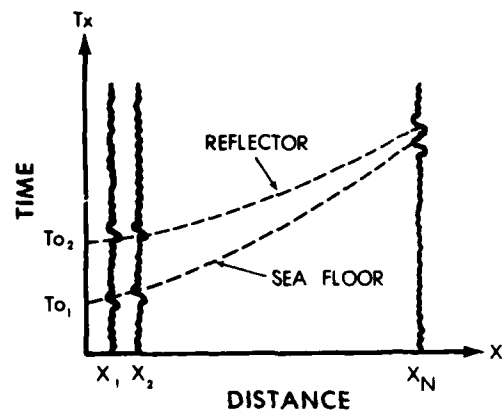
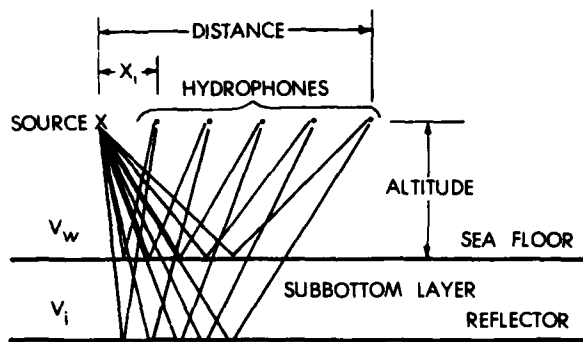

Figure 11. System Comparison: Deep-Towed Versus Conventional Surface-Towed

The first trade-off is for a conventional surface-towed system in 4500 m of water compared against a deep-towed system at an altitude of 100 m. The surface-towed array length is 3600 m long, where the deep-towed array is 1000 m long. The standard deviation in layer compressional wave speed is plotted against the thickness of the subbottom layer.

The statistical analysis used in this trade-off and subsequent comparisons and performance predictions employed a uniform probability distribution for predicting the precision of measuring (picking) reflected energy arrival times. The limit on the distribution was  $\pm 0.5$  ms, designated as picking error on the figures. The low picking errors require, as primary factors affecting this error, high signal-to-noise and accurate knowledge of array shape. Both areas are being optimized during the deep-towed system design with the picking error goal of  $\pm 0.5$  ms. Initial analysis for the deep-towed configuration indicates that these low-picking errors are feasible. The picking error of  $\pm 0.5$  ms was used regardless of the system configuration for these trade-offs, thus providing an equal basis for system comparisons.

As can be seen, the performance of the deep-towed system is considerably better than the surface-towed system. It should be pointed out that the 3600 m array length for the surface-towed system is basically the state-of-the-art used in the oil exploration industry.

# COMPRESSIONAL WAVE SPEED ERROR FOR SURFACE-TOWED AND DEEP-TOWED SYSTEMS

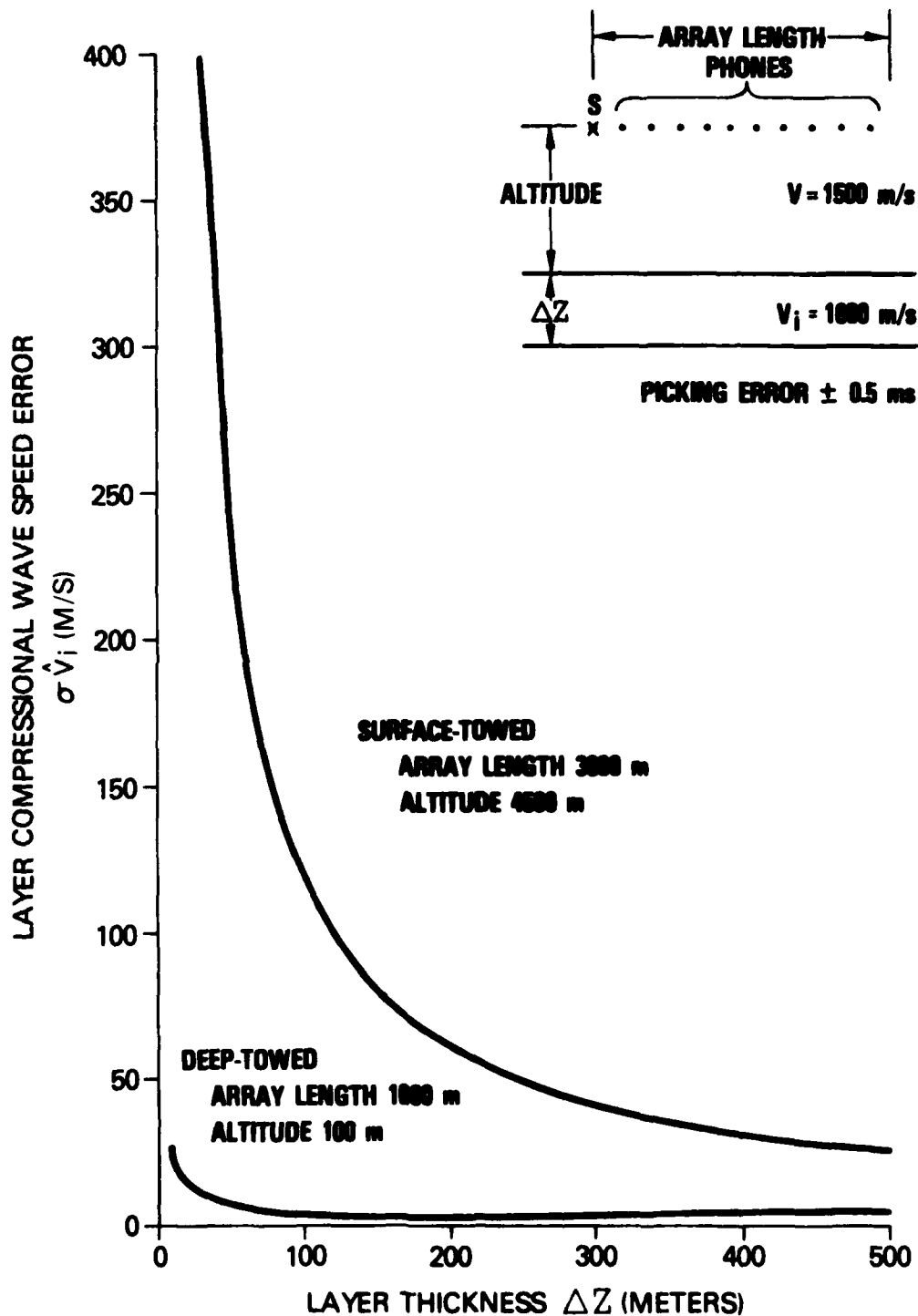

**Figure 12. System Comparison: Deep-Towed Versus Surface Source/Deep Array**

The next trade-off is for a deep-towed array and a surface source, again comparing it with a deep-towed system. As can be seen, the error in compressional wave speed is much less for the deep-towed system as compared to the deep-towed array/surface-source. It should be noted that the error for very thin layers is much less with the deep-towed system, as in the last figure.

# COMPRESSIONAL WAVE SPEED ERROR FOR SURFACE SOURCE/DEEP ARRAY AND DEEP SOURCE/ARRAY

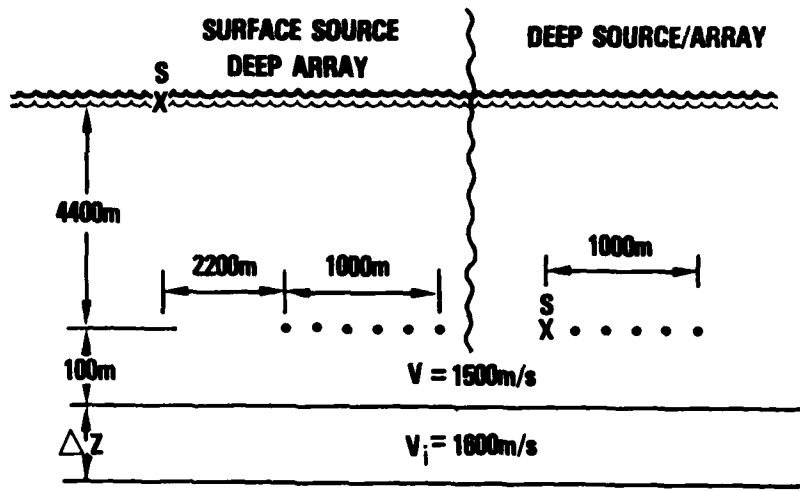

PICKING ERROR  $\pm 0.5ms$

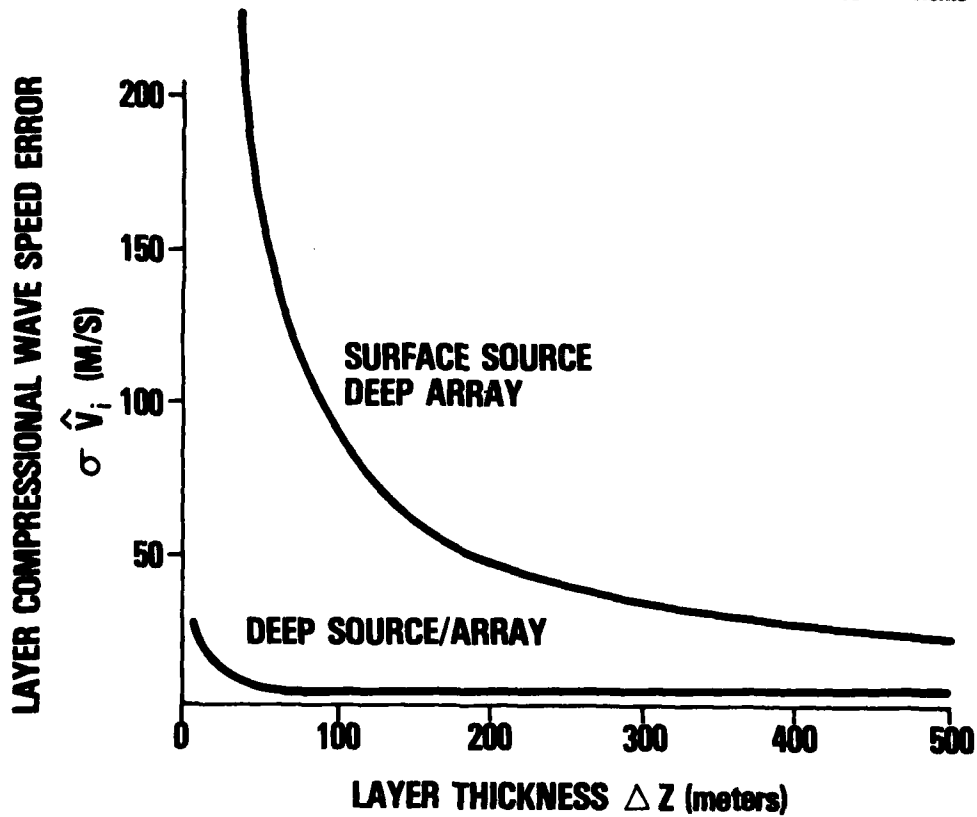

**Figure 13. System Comparison: Deep-Towed Versus Long Surface-Towed Array**

It is not until a very long surface-towed array is used that the performance approaches the results of a deep-towed system, and then only for layers greater than 250 m thick. The surface array was 15 km long, compared to the 1000 m long deep array and deep source system. The basic scientific requirement for high vertical resolution (resolving thin layers) would preclude using even a very long array, at least in deep water, as is evident from this performance comparison.

# COMPRESSIONAL WAVE SPEED ERROR FOR SURFACE-TOWED AND DEEP-TOWED SYSTEM

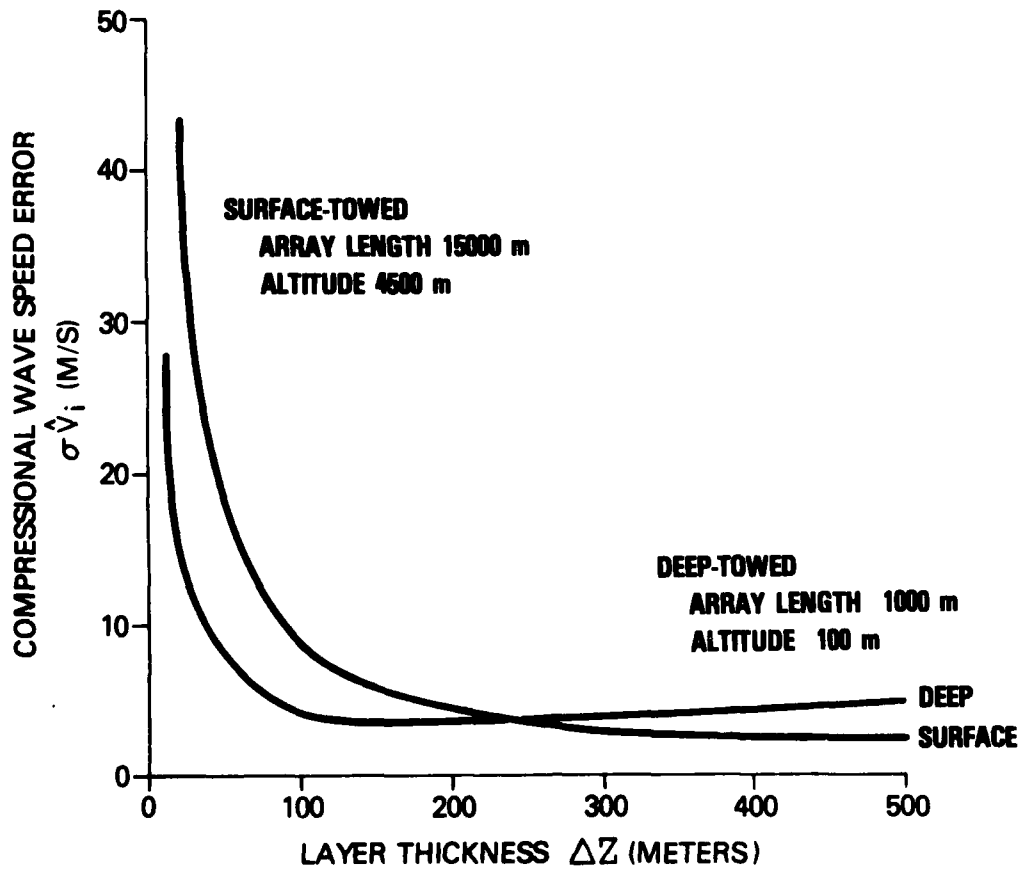
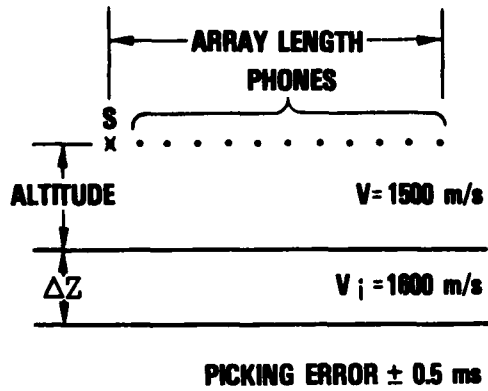

**Figure 14. Performance Trade Off: Array Length**

A series of trade-offs for the different basic system parameters was also performed. Presented here is the trade-off for array length, again plotting layer compressional wave speed error against layer thickness. As can be seen, a 500 m long array does not perform as well as the 1000 m or 2000 m long array. A 1000 m long array has been selected for the initial design but this could be changed based on additional performance and operational assessments. The 1000 m long array is a practical length for towing in the operational configuration envisioned for the system.

# COMPRESSIONAL WAVE SPEED ERROR ARRAY LENGTH TRADE-OFF

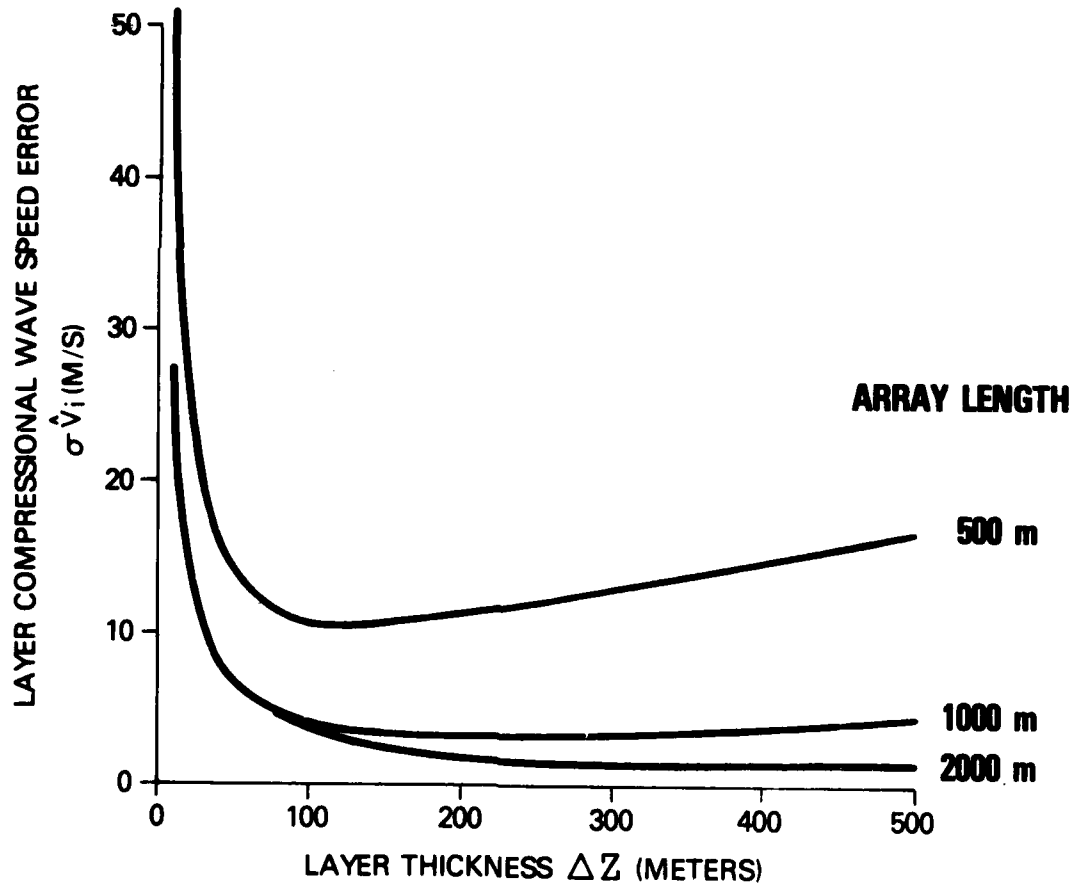
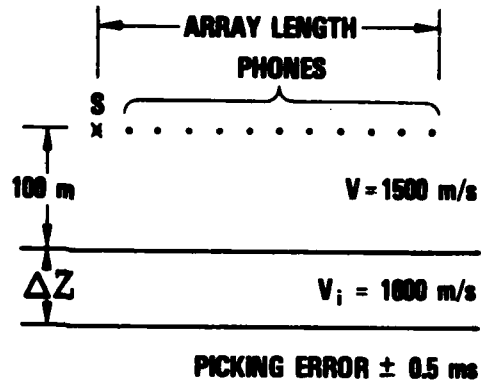

### Figure 15. Geoacoustic Parameter Measurement

In addition to the high resolution measure of compressional wave speed for thin layers, the capability also exists to extract other input parameters for geoacoustic models. For the example shown in the first part of the figure, the compressional wave speed has been computed for subbottom interface just below the water/sediment interface. Again, high precision is achieved. Critically important is that the deep-towed system provides the potential, with its unique data set, to compute the compressional wave speed gradients of the subbottom layers. The second part of the figure shows the results of the gradient estimate. In addition, as shown in the last part of the figure, subbottom layer thickness can be determined very accurately. The details of the data analysis approach to extract geoacoustic parameters is given in NORDA Report 30, "A Moments Approach for Analyzing Geophysical Acoustic Reflection Data."

# DEEP-TOWED SYSTEM GEOACOUSTIC PARAMETER MEASUREMENT PERFORMANCE PREDICTION

10 SHOT AVERAGE  
PICKING ERROR  $\pm 0.5$  ms

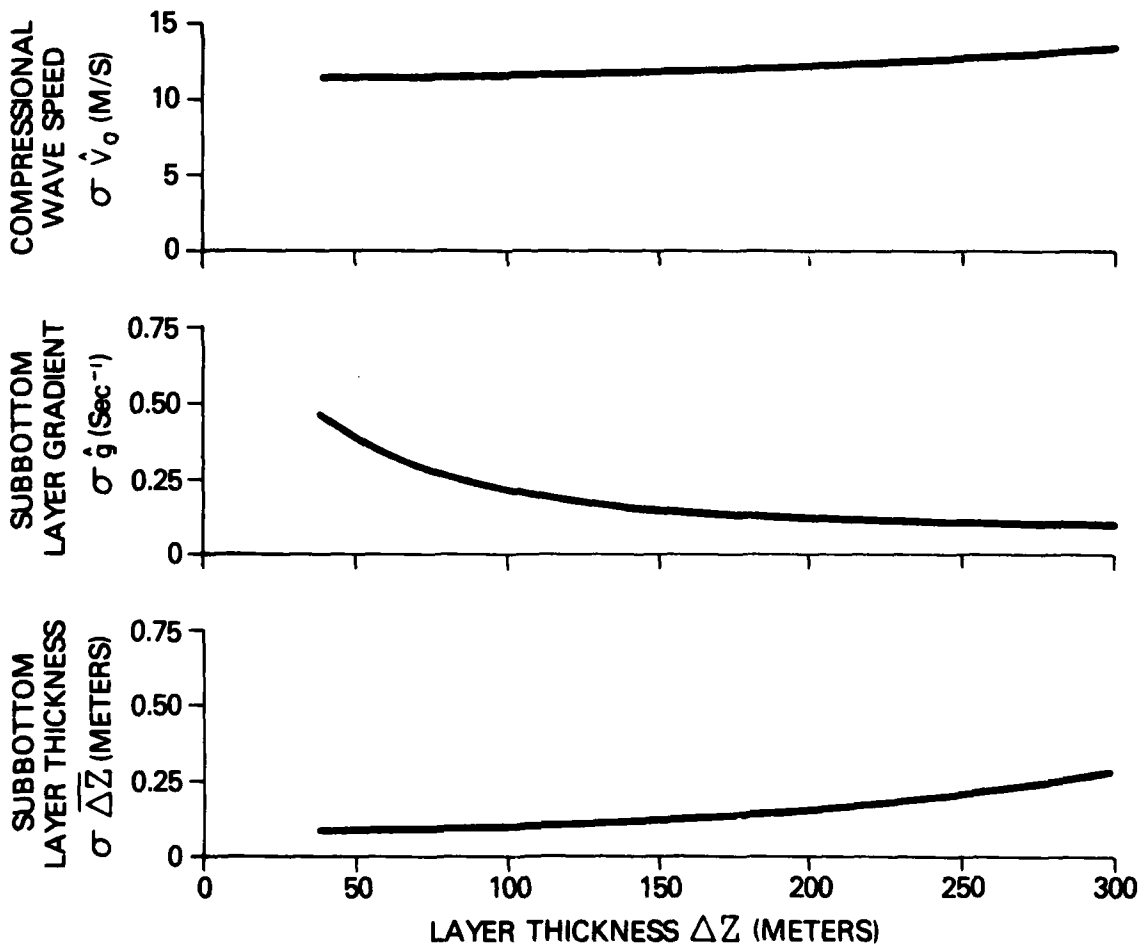
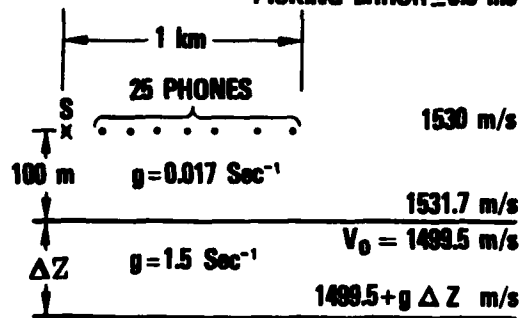

## Figure 16. Acoustic Footprint

In addition to the ability to measure the geoacoustic parameters, a much smaller acoustic footprint of the bottom and subbottom is provided with a deep-towed system, thus improving the spatial resolution of these parameters.

Shown here is the sea floor footprint resulting from near-field beamforming of multiple shots. The same multi-shot type processing was used for the surface-towed and deep-towed system. This processing is generally referred to as common depth point analysis. Only a small area is in focus for the deep-towed system, resulting in a footprint that is substantially smaller than obtained with a surface-towed system. The array system is analogous to cameras; the depth of field is much less when focused on something close and objects outside this focused region are blurred and do not constructively contribute to the image. This high spatial resolution is certainly an advantage in determining a high resolution measure of the geoacoustic parameters.

# PROCESSED DATA FOOTPRINT COMPARISON SURFACE-TOWED AND DEEP-TOWED SYSTEMS

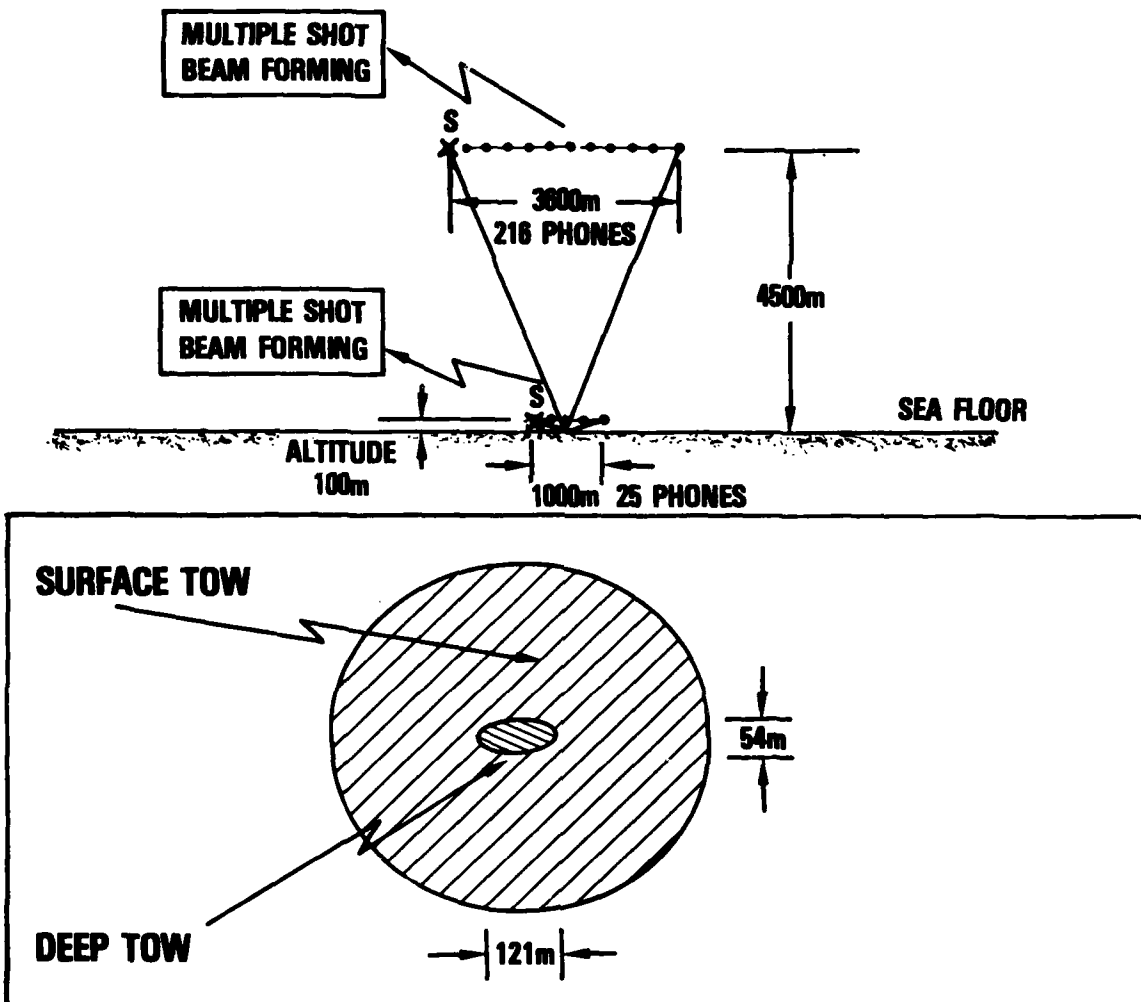

### Figure 17. Additional Scientific Capabilities

An additional scientific capability provided is the potential to deduce reflectivity and absorption from attenuation measure. By coupling the deep-towed high resolution data set with laboratory and subsequent modeling, a much better handle on understanding the absorption of the subbottom will result.

A high lateral sampling interval results from firing the source at 20 m intervals along track, thus allowing a geoacoustic parameter measure at each shot point. This will provide a capability to assess the lateral variability of these parameters. A high vertical sampling results from the large bandwidth source and will provide a high resolution time profile (seismic trace) and, when coupled with compressional wave speed, provides a high resolution depth picture.

When this high resolution measurement capability is coupled with deep-ocean drill sites for stratigraphic control, the ability will be provided to map the detailed stratigraphy of deep-ocean basins, thus providing a detailed geological description. In the deep ocean the system will also provide high resolution site surveys for installation of bottom-mounted/implanted systems.

## **ADDITIONAL SCIENTIFIC CAPABILITY**

### **POTENTIAL TO DEDUCE REFLECTIVITY AND ABSORPTION FROM ATTENUATION MEASURE**

- Broad Acoustic Frequency Look (50-1000Hz)
- Precise Travel Path Length Determination
- Reduce Water Path Uncertainty

### **HIGH LATERAL SAMPLING INTERVAL**

- Geoacoustic Parameter Measure Every 20m Along Track

### **HIGH VERTICAL SAMPLE INTERVAL**

- High Resolution with 500Hz Bandwidth Source
- Improved Time/Depth Picture of Subbottom Strata

### **DEEP OCEAN SITE STUDIES**

- Geoacoustical
- Foundations and Facilities

Figure 18. DTAGS Scientific Capability Provides

In summary, the scientific capability of the Deep-Towed Geophysical Array System will provide a detailed quantitative description of the sea floor and subbottom structure in the areas of:

Seismic Stratigraphy--the character, distribution, and structure of sediments and sedimentary strata.

Geomorphology--the bedform configuration, subbottom microtopography, and basement roughness.

Geoacoustics--the compressional wave speed, compressional wave speed gradient, absorption (when coupled with laboratory measurements and modeling), and layer thickness.

# **DEEP-TOWED GEOPHYSICAL ARRAY SYSTEM**

**PROVIDES**

**A Detailed Quantitative Description  
of the Sea Floor and Subbottom**

- **SEISMIC STRATIGRAPHY**
- **GEOMORPHOLOGY**
- **GEOACOUSTIC**

## Figure 19. Major Technology Development Areas

The system will not only provide a unique scientific capability, but will also provide major contributions in the area of deep-water measurement technology.

One of the major, and probably the most critical, development areas is the deep-towed (or moored) low frequency sound source. This development will require assessing and successfully resolving basic areas related to operating frequency, bandwidth, and the required source level to meet the geophysical application. Certainly a concern is providing a physical size that is compatible with a deep-towed configuration.

The deep-towed array development will require assessing such areas as the stability/motion response and defining the engineering sensors required to measure this response, and the physical size considering handling, winching, deployment and retrieval. Modeling of the array performance, physical and measurement characteristics, will continue and be refined upon establishing more definitive hardware characteristics and performing field validation experiments.

The communication system will require driving very long tow cables, thus raising such questions as: What is the bandwidth and attenuation of these cables? Can digital data be driven up these cables? The physical characteristics of these cables optimized for reliability will require assessing such areas as strength, weight, size, and durability. Present plans, based on projected data rates and power handling requirements, indicate that a conventional coaxial tow cable is a feasible approach. In the future if data rates are increased (for example, more hydrophone channels required), the use of a coaxial steel cable with a fiber optic capability may be required. Close coordination with the fiber optic cable developments will be maintained.

The navigation system will require tracking the deep-towed package (fish) and array. This will result in an understanding of the problems and solution encountered when tracking deep-towed systems. Related to the tracking problem is knowledge of the system response due to ship maneuvers. How do you maintain a prescribed track for a system at the end of 9000 m of tow cable? This system development will provide an insight to answering these type questions.

A more detailed review of these areas is presented by discussing results of some past studies.

# MAJOR TECHNOLOGY DEVELOPMENT AREAS

## DEEP SOUND SOURCE (6000m)

- Low Frequency/Bandwidth/Level
- Type - Piezoelectric/Mechanical
- Size/Weight/Tow Body

## DEEP-TOWED ARRAY

- Stability/Motion Response
- Analytical Model - Validation/Instrumentation
- Handling - Winching/Deployment/Retrieval

## COMMUNICATION

- Drive Long Cables - Bandwidth/Attenuation
- Cable
  - Strength/Weight/Size/Durability
  - Coaxial/Fiber Optic

## NAVIGATION

- Track Deep Towed System
- Steerage - System Response

## Figure 20. Deep Sound Source Overview

The first technology area to be addressed in more detail is one of the most critical for the successful completion of the deep-towed geophysical array system: the low frequency deep-towed sound source. The basic requirement is to provide a system with the acoustic characteristics matched for the geophysical application. This requires providing sufficient energy to penetrate up to 500 m of subbottom structure at a 6000 m operating depth with a towable package. Two basic approaches are being pursued for sound generation: the first is a piezoelectric Helmholtz resonator transducer and the second is a hydromechanical, hydroacoustic, impulse device. The latter approach is probably a higher development risk, but its acoustic characteristics are more optimum than the Helmholtz device.

# DEEP SOUND SOURCE

## REQUIREMENTS

- Acoustic Character Match Geophysical Application
- Operating Depth To 6000m
- A Towable Package

## APPROACHES

- (1) Piezoelectric - Helmholtz Resonator Transducer
- (2) Hydromechanical - Hydroacoustic Impulse Source

### Figure 21. Helmholtz Transducer Pictorial

This figure presents a cutaway view of the conceptual design for the Helmholtz transducer. The work on this approach is being performed by the Naval Research Laboratory/Underwater Sound Reference Detachment.

The transducer consists of a Helmholtz cavity and orifice driven by a piezoelectric-segmented ceramic ring driver. One surface of the ceramic ring drives the Helmholtz cavity, while the other surface radiates into the exposed outside medium (the sea). At the Helmholtz resonance frequency, radiation from the orifice and exposed surface are in phase. The Helmholtz resonance "boosts" the low frequency response of the ceramic driver and, combined with the natural higher frequency response of the ceramic, produces a relative broadband, high level, acoustic signal. The ceramic driver is oil-filled and the Helmholtz cavity is free-flooding; therefore, the transducer operation is independent of depth.

# CONCEPTUAL DESIGN FOR LOW FREQUENCY DEEP TOW SOURCE

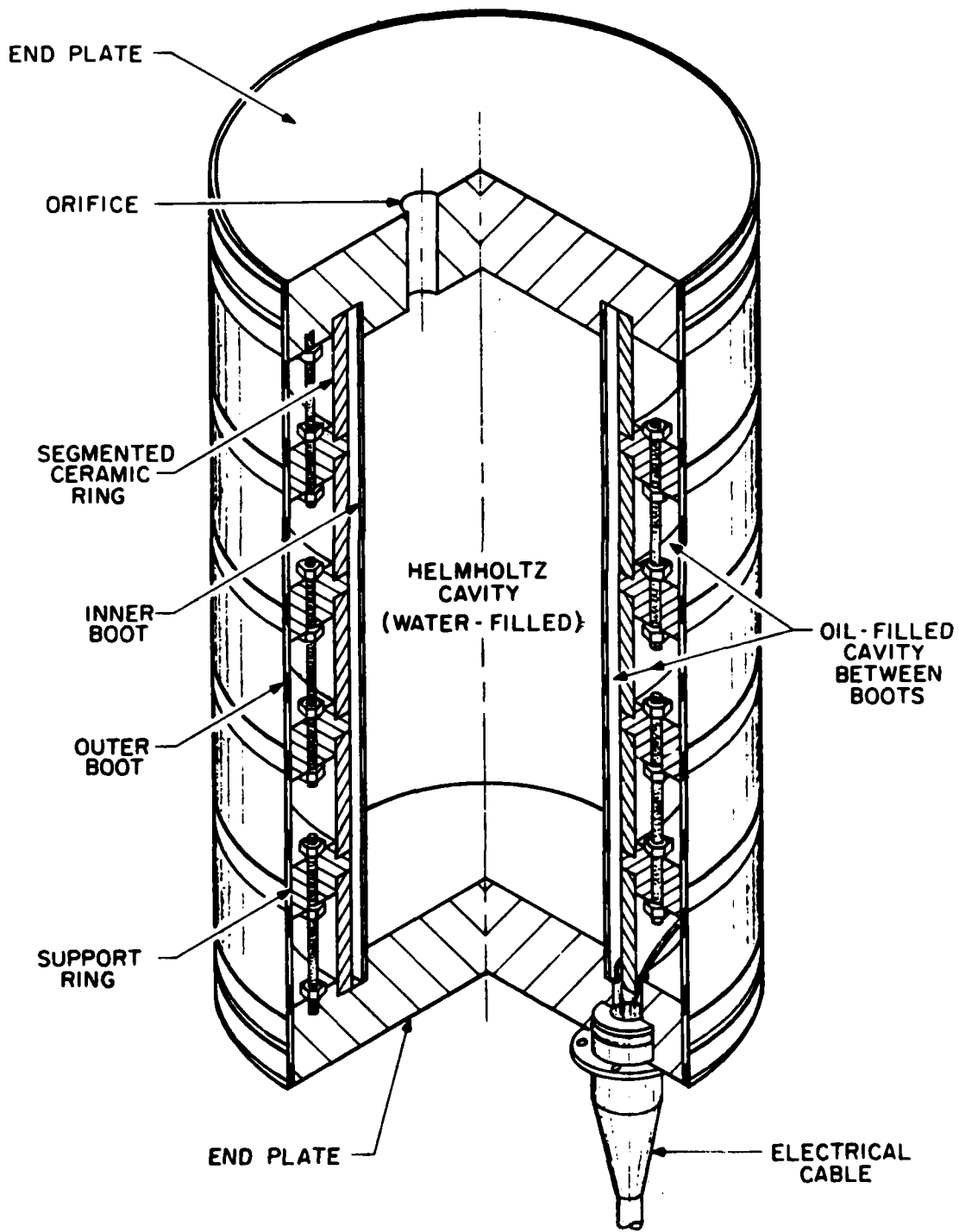

## Figure 22. Helmholtz Transducer Specifications

The basic design parameters for the Helmholtz transducer are identified. A performance prediction analysis (for typical subbottom models) indicates sufficient source level for the desired penetration when the source level of the device is combined with the near-bottom proximity operating mode. A surface source in 4500 m of water would require an additional 33 dB of source level to match a deep source operating at an altitude of 100 m due to the spreading loss. In addition, the Helmholtz source system will be capable of transmitting a long pulse (up to 250 msec) with appropriate coding to allow increasing the time-bandwidth product, thus providing additional signal processing gain. The initial assessment identified two models, differing primarily in their length. The longer unit, although heavier, provides increased efficiency, which is evident by the peak power required.

**DEEP TOWED LOW FREQUENCY SOUND SOURCE  
HELMHOLTZ RESONATOR TRANSDUCER  
SPECIFICATIONS**

● SOURCE LEVEL	204dB// $\mu$ Pam	● SIZE	MODEL 1 0.5m DIA X 0.9m long MODEL 2 0.5m DIA X 1.8m long
● FREQUENCY	400 Hz	● WEIGHT (AIR)	MODEL 1 500 kg. MODEL 2 1020 kg.
● BANDWIDTH	200 Hz	● WEIGHT (WATER)	MODEL 1 380 kg. MODEL 2 775 kg.
● PULSE REPETITION RATE	1 PER 15 SEC	● PEAK POWER	MODEL 1 34 KVA MODEL 2 17 KVA
● OPERATING DEPTH	FULL OCEAN		

**Figure 23. Hydroacoustic Impulse Sound Source Pictorial**

Pictured is a cutaway view of the conceptual design for the hydroacoustic impulse sound source. The basic operation of the unit is as follows: the radiating piston is cocked (as pictured) and latched in this position, while the pressure in the oil-filled sphere behind the piston is reduced approximately 5,000 psi below the outside ambient pressure. Then, the radiating piston latch is suddenly released, allowing the radiating piston to rapidly retract and, finally, the sudden deceleration of this piston by the dashpot creates a positive high level acoustic impulse.

# DEEP-TOWED LOW FREQUENCY HYDROACOUSTIC IMPULSE SOUND SOURCE

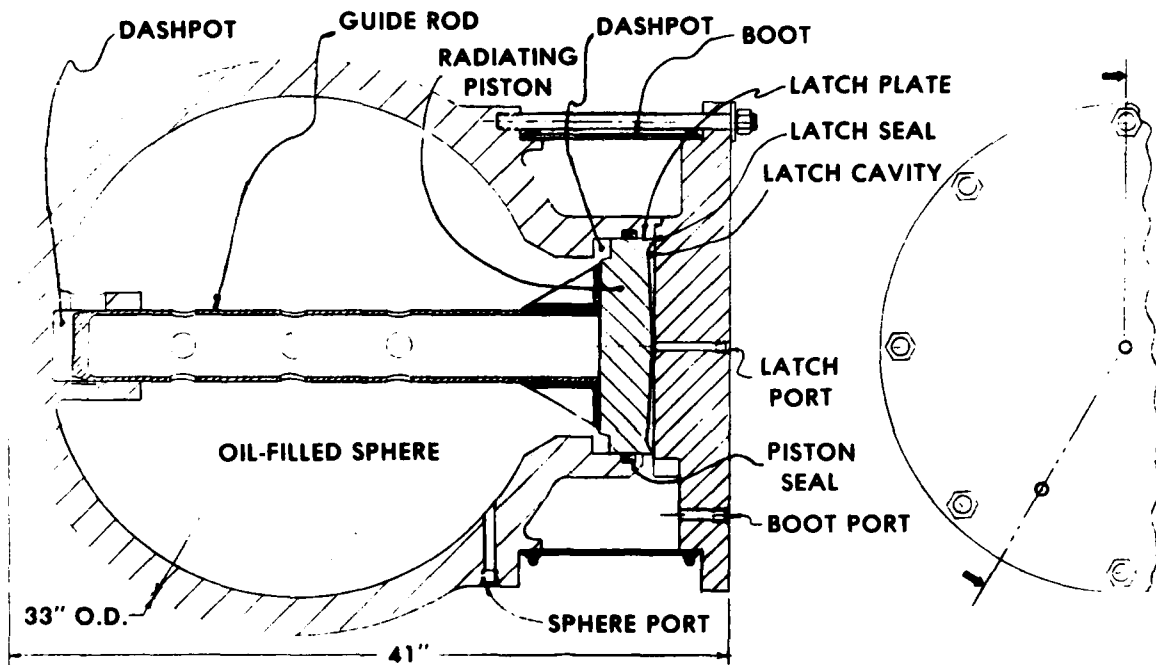
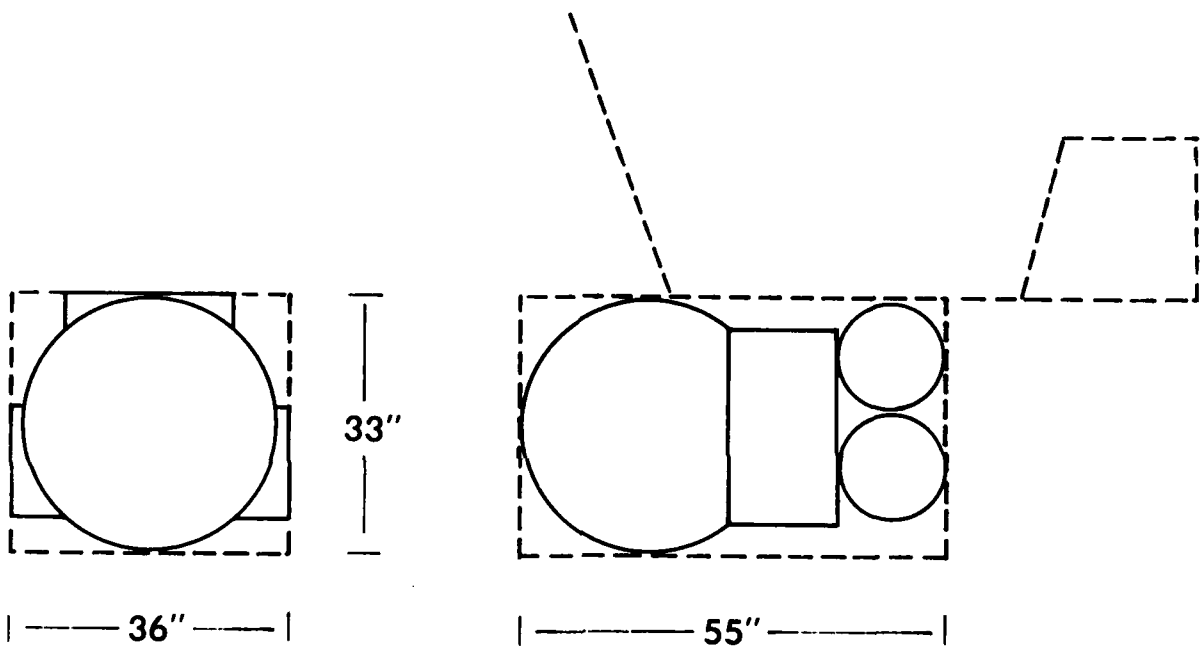

Figure 24. Hydroacoustic Impulse Sound Source Towing Configuration

This figure provides a better visualization of the source size. The radiating source is the larger of the units, while the control electronics and hydraulic pumping system are contained in the two smaller cylinders. Although the source is relatively large, it is still a physical size that is practical for towing.

1  
2  
3  
4  
5  
6  
7  
8  
9  
10  
11  
12  
13  
14  
15  
16  
17  
18  
19  
20  
21  
22  
23  
24  
25  
26  
27  
28  
29  
30  
31  
32  
33  
34  
35  
36  
37  
38  
39  
40  
41  
42  
43  
44  
45  
46  
47  
48  
49  
50

# IMPULSE SOUND SOURCE TOWING CONFIGURATION



### Figure 25. Hydroacoustic Impulse Sound Source Parameters

The parameters for the impulse sound source are listed. As can be seen, the source level is higher than the Helmholtz device. This provides without additional signal processing high signal-to-noise, thus providing high-quality data for extraction of the geoacoustic parameters. In addition, a higher spectral level across a broad acoustic band from 200 to 700 Hz is being explored for the geophysical application. Also, substantial energy over an even broader acoustic band from 100 Hz to 1000 Hz will be evident in the next figure showing a spectral plot. Since this is a differential pressure device, there is full output power when the device reaches a depth equivalent to 5000 psi, approximately 3400 m. In shallower operating depths the source level will be reduced, but a substantial energy still exists; for example, at a 2000 m operating depth, the level drops by 6 dB.

The physical parameters for the proposed system are also given with the total in-water weight of about 1100 pounds, excluding the tow body. A design goal for the total deep-towed package is 2000 to 2500 pounds. This weight is compatible with the projected operating scenario.

# HYDROACOUSTIC IMPULSE SOUND SOURCE PARAMETERS

Acoustic Source Level, (dB re $1\mu\text{Pa}$ @ 1m)	224
Peak Spectral Level, (dB re $1\mu\text{Pa}^2 \cdot \text{sec}/\text{Hz}$ @ 1m)	172
Bandwidth, -3 dB (Hz)	200 - 700
Depth for Full Output (meters)	3400 - 8000
Radiating Piston Diameter (inches)	12
Piston Stroke (inches)	1.0
Repetition Rate (seconds)	17
Input Power (KW, 60Hz)	10

	<u>SOURCE</u>	<u>POWER SUPPLY</u>	<u>JUNCTION BOX</u>	<u>SYSTEM TOTAL</u>
Weight in Air (lb)	1300	385	300	1985
Weight in Water (lb)	600	290	200	1090
Diameter (in)	33	12	12	36 wide x 33 high
Length (in)	41	36	24	55

**Figure 26. Hydroacoustic Impulse Sound Source Acoustic Spectrum**

The spectral characteristics are fairly broadband, as noted earlier. The substantial energy in the low frequency end of the spectrum will be exploited, especially in assessing the absorption character of the subbottom.

# HYDROACOUSTIC IMPULSE SOUND SOURCE ACOUSTIC SPECTRUM

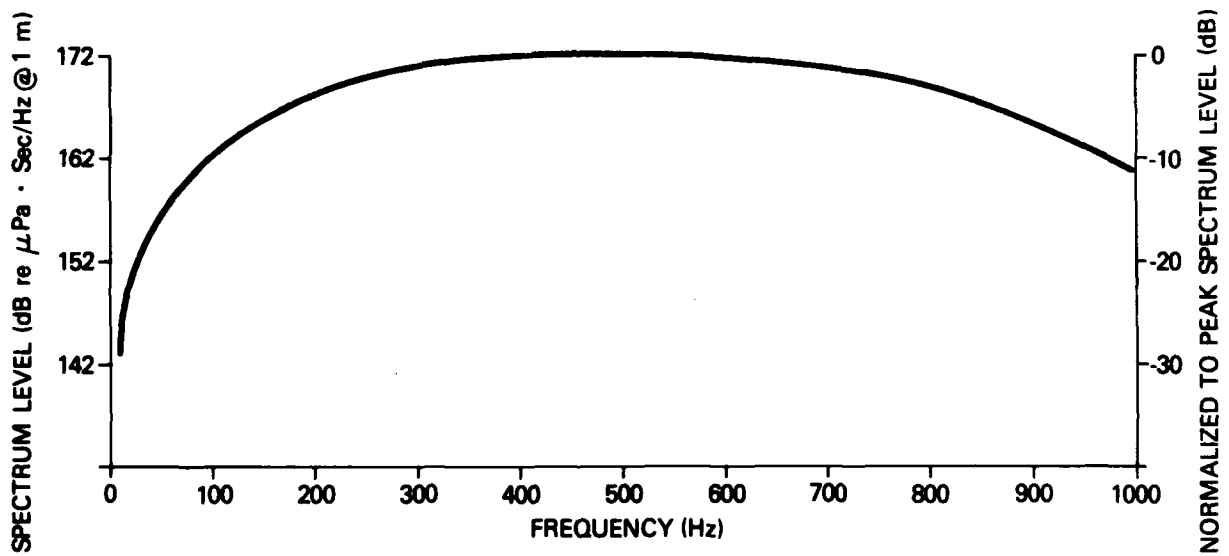

**Figure 27. Deep-Towed Array**

Listed here are some basic projected array characteristics. Although these parameters were used in the preceding performance prediction analysis for the deep-towed system, refinement prior to establishing the final system characteristics is continuing. Additional studies and experiments will be performed to examine the areas identified in more detail. One of the areas relates to dynamic motion response of the system, and some results are shown in the next figure.



# DEEP-TOWED ARRAY

## REQUIREMENTS

- Length 1000m
- Hydrophones 25
- Hydrophone Spacing 40m
- Operating Depth to 6000m
- Knowledge of Shape
- A Towable Package

## EXAMINE

- Steady-State Response (Place at Preselected Depth)
- Dynamic Response (Motion of Deep-Towed Package)
- Deformation Correction (Computation Techniques/Engineering Sensors)
- Implementation (Construction Material/Fabrication Techniques)
- Deployment/Retrieval (Operational Scenario)

**Figure 28. Predicted Dynamic Response: Fish/Array**

This dynamic system response analysis predicts the motion at the fish and array caused by the ship motion. The analysis predicts how the motion is translated down the tow cable to the deep-towed system. The figure presents the vertical displacement at the fish and at a point on the array for two cases. The first case is for a tow cable length of 9150 m (30,000 ft) and, as observed, some fish motion but very little motion is translated to the array. The second case is for a shorter tow cable, and although there is more motion at the fish, very little motion is translated to the array. It should be pointed out that these results are preliminary and as the system parameters are refined the analysis will be updated.

# PREDICTED DYNAMIC RESPONSE

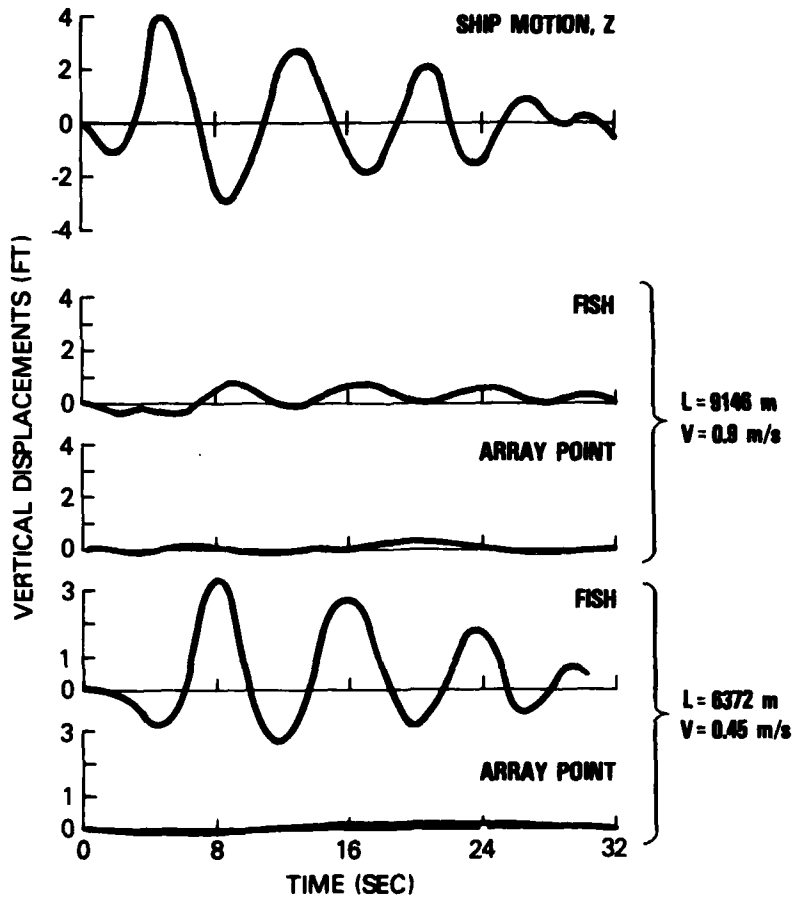
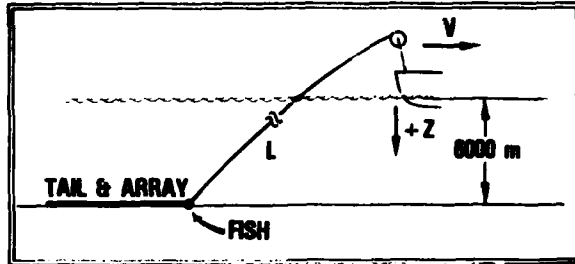

## Figure 29. Communication Requirements

Identified are some of the basic requirements for the communication system. As pointed out earlier, the system is required to drive very long cables, with present plans to employ a digital time division multiplex approach. Critical to this approach is knowledge of the transfer characteristics, phase and amplitude, of the tow cable. The next figure will show measurements performed on a candidate type cable. The projected system requirements are for a 50-channel capability, 27 high data rate channels for acoustic data and 23 low data rate channels for engineering data. Since the development program requires a total quantitative data acquisition capability, there is a strong need for large dynamic range. Present plans call for utilizing true gain 16-bit floating point amplifiers. Combining the total system data requirements leads to a digital data rate of 1.4 million bits/sec. We feel that these data rates are compatible with an R8U type coaxial steel tow cable without the use of repeaters if careful cable compensation network design is employed.

# COMMUNICATION

## REQUIREMENTS

- Digital Communication Over 9150m Coaxial Tow Cable
- 50 Channel Capability
  - 27 High Data Rate - Hydrophones
  - 23 Low Data Rate - Engineering Sensors
- 100dB Dynamic Range
  - Utilize Floating Point Amplifiers
- 72dB Crosstalk Reduction
- 1.4 MBITS/SEC Data Rate

**Figure 30. Coaxial Tow Cable Transfer Function**

Some work has been done in assessing the requirement to drive high digital data rates up the coaxial tow cables. This figure presents the attenuation and phase characteristics of a shorter cable length, but of the same basic design, both electrical and mechanical, planned for the operational cable. These measurements were well-behaved, with no change electrically for low tension load to full load, indicating accurate prediction for cable compensation network designs. Similar measurements for full cable lengths are planned prior to compensation network design.

# COAXIAL TOW CABLE TRANSFER FUNCTION

CABLE LENGTH 4.8 km

CORE ~ RG-8U

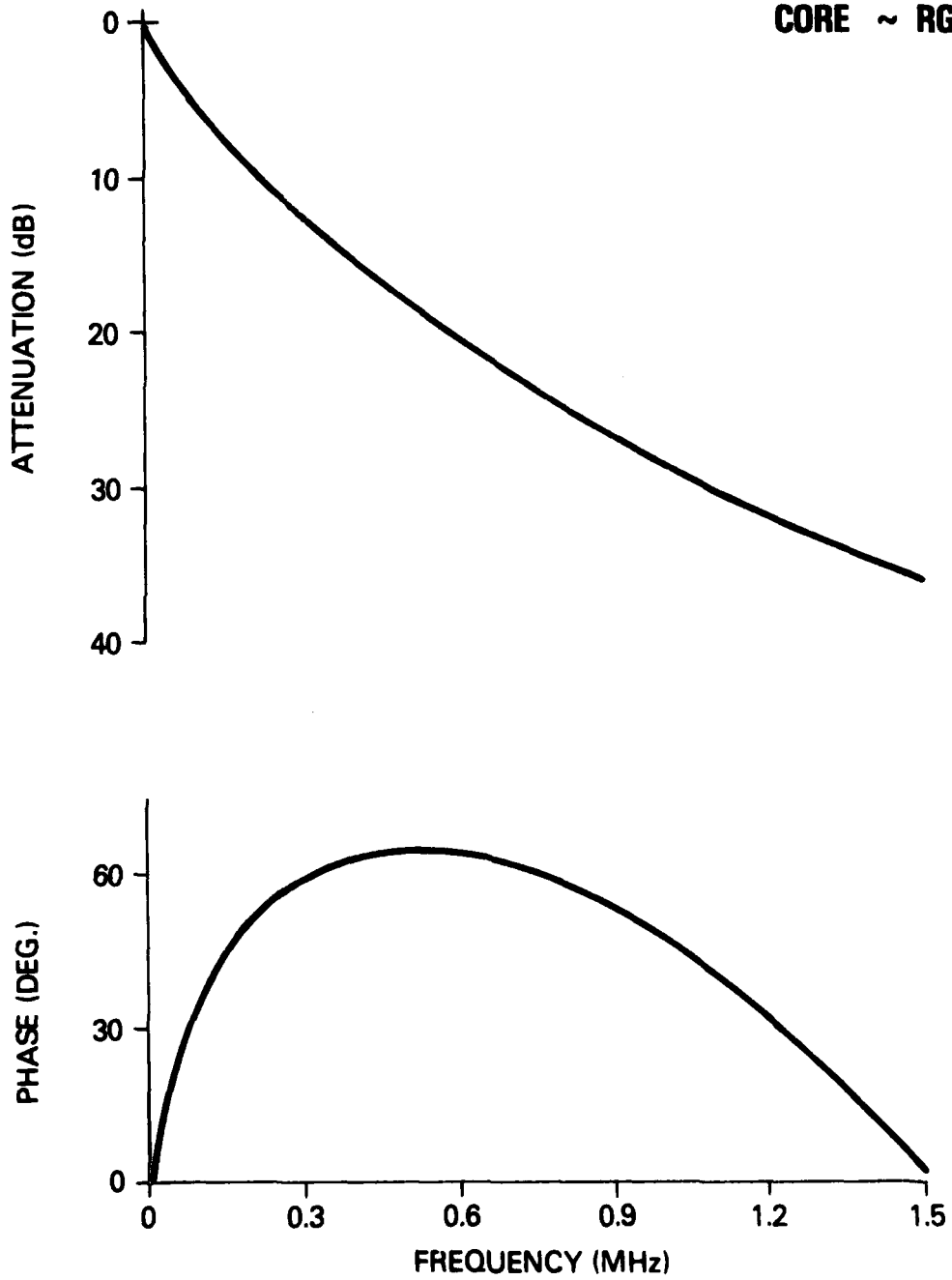

### Figure 31. Navigation Requirements

Identified are the basic requirements for navigation of the deep-towed system. Employing standard data processing techniques utilized by the oil exploration industry, such as common depth point stacking, requires the source to be fired at fixed distances along track. Meeting this requirement with the desired precision will require that a doppler navigator be located at the deep-towed fish. A three-axis configuration is planned, thus providing additional information on fish motion for incorporation into static corrections (i.e., altitude and drift of source between shots). The initial operation of the system will be in reconnaissance survey mode, consisting primarily of running single tracks through the area of interest. A short base line navigation system will be employed to position the deep-towed package relative to the tow ship. This short base line navigation system, coupled with the doppler navigator and the array engineering sensors, will provide the instrumentation required to measure the deep-towed system response and will aid in maintaining a fixed track due to system and ship steering charges induced by environmental factors. The system response information in itself will provide a unique data set to allow validation of deep-towed system (array and/or fish) motion analytical model predictions. Anticipated for the future is the need to run grid tracks, which will impose a requirement for a bottom transponder type navigation suit.

# NAVIGATION

## REQUIREMENTS

- Fire Source at Fixed Distance Along Track  
Deep-Towed Doppler Navigator
- Position Fish/Array Relative to Tow Ship  
Short Base Line Navigation
- Maintain Track and Tow Depth  
System Response  
Ship Steerage
- Run Grid Tracks (Anticipated for Future)  
Transponder Net

### Figure 32. Data Processing Requirements

Although not discussed up to this point, the data processing requirement is critical to the development program. Field data preprocessing will be maximized. This may include, in addition to the areas identified on the figure, field static corrections. Incorporating static correction into the field preprocessing package will not be adopted until a more detailed analysis is performed on the exact processing required. The field data format will be compatible with industry standards, thus providing the ability to employ standard software routines and the option to process the data by the academic community or private industry. The flexibility to employ unique commercial processing techniques, such as color-enhanced displays, without the large capital investment associated with these techniques is also provided.

As pointed out previously, the main scientific product is a high quality measure of the geoacoustic parameters. This product will require the development of improved and/or new processing techniques for the extraction of these geoacoustic parameters from the unique high resolution field data set. The initial effort was summarized in Figure 15, which shows the estimated error in compressional wave speed at the water/sediment interface, layer compressional wave speed gradients, and layer thickness. Coupled within the data processing requirement is an interactive data processing/display capability. Since the prime goal is a high-quality geoacoustic parameter measure on a relatively small quantity of data, it is strongly felt that interaction by the geologist, geophysicist, and acoustician in the data processing loop, to a greater extent than possible in large quantity production processing, is essential.

# DATA PROCESSING

## REQUIREMENT

- Maximize Field Pre-Processing
  - Data Quality Control
  - Demultiplex
  - Edit
- Data Format Compatible with Industry Standard
- Employ Standardized Software Routines to Extent Possible

### Typical

- Static Corrections
- CDP Gather
- NMO and Stack
- Semblance Velocity Scan
- Band Pass Filter
- Time/Spatial Gain
- Geoacoustic Parameter Extraction
- Interactive Data Display

**Figure 33. Deep-Towed Geophysical Array System Capability Summary**

The Deep-Towed Geophysical Array System program is a blend of developing a new deep-ocean technology capability and providing a unique scientific measurement capability. Each of these areas crossbreed to optimize a capability for the Navy and the marine science community to better define the geological, geophysical, and geoacoustic character of the sea floor and subbottom in the deep ocean. Although the program has focused on a geophysical application, many areas in both the scientific and technology arenas will benefit from this development effort. Some of these areas were identified, but we are sure many more will be revealed by the energetic scientists and technologist.

# DEEP-TOWED GEOPHYSICAL ARRAY SYSTEM

## SCIENTIFIC CAPABILITY

- Geological Description
- Geoacoustic Parameters
- Sea Floor Coherence Studies
- Deep Ocean Site Studies
- Noise Measurements

## TECHNICAL CAPABILITY

- System Performance Characterization
- Deployment/Retrieval/Operation
- Low Frequency Sound Source
- Hydrophone Array
- High Data Rate Communication
- Navigation
- Data Processing

**BETTER PROPAGATION PREDICTION  
FOR NAVAL SYSTEMS**

Figure 34. Plans: FY81 and FY82

The system hardware development is planned to commence at the start of FY81 (October 1980). The initial effort will be the fabrication of the Helmholtz sound source system, with a parallel engineering design of the hydroacoustic impulse sound source. An existing research array will be modified to include additional engineering sensors and this array will then be interfaced with the Helmholtz sound source. Although this array will not be optimized for the geophysical application, it will allow deep-tow performance characterization in the areas of: motion prediction, depth control, deployment/retrieval operational scenario evaluation, high data rate communication, and acquisition of geophysical data. This effort will reduce the technical risk associated with development of the optimum array. The software development will be initiated to provide a basic capability to process data from a planned late FY81 sea test. The sea test will be a field evaluation of the Helmholtz sound source and research array. This test will provide the basic data set to: refine performance requirements for the more acoustically optimum impulse sound source, assess array deformation correction requirements, and allow refined development of the data processing software for extraction of geacoustic parameters.

The fabrication of the impulse sound source will be initiated during FY82. In addition, the major subsystem identified in the figure will be procured and fabricated, and interfacing of these sub-systems will be initiated. The software development will continue employing the data set from the FY81 field test.

# DEEP-TOWED GEOPHYSICAL ARRAY SYSTEM PLANS

## FY81

- Fabricate Helmholtz Source System
- Fabricate Array
  - Modify Existing Array
- Engineering Design of Hydroacoustic Impulse Sound Source
- Initiate Software Development
- Field Test Source/Array System

## FY82

- Initiate Hydroacoustic Impulse Source System Fabrication
- Procure/Fabricate/Interface/Test Sub-Systems
  - Array
  - Telemetry
  - Navigation Suite
  - Deployment/Retrieval Hardware
  - Data Recording System
- Continue Software Development

**Figure 35. Plans: FY83 and FY84**

FY83 will see the completion of the impulse sound source, subsystems, processing software, and total system integration. The year will end with an engineering field test to evaluate the total Deep-Towed Geophysical Array System. The experiment will focus on obtaining a quantitative definition of system performance.

The FY84 effort will be initiated with a detailed analysis of the field test data, and these results will be compared with the model performance prediction to provide a precise quantitative definition of system performance. Modification will be performed, if necessary, based on the test results. Total system documentation will be completed.

# **DEEP-TOWED GEOPHYSICAL ARRAY SYSTEM**

## **PLANS**

### **FY83**

- Complete System Fabrication/Interface  
Impulse Source System  
Sub-Systems
- Complete Software Development
- Field Test Total Deep-Towed System

### **FY84**

- Analyze Data
- Complete System Documentation

UNCLASSIFIED

SECURITY CLASSIFICATION OF THIS PAGE (When Data Entered)

REPORT DOCUMENTATION PAGE		READ INSTRUCTIONS BEFORE COMPLETING FORM
1. REPORT NUMBER NORDA Technical Note 75	2. GOVT ACCESSION NO. AD-A09W 801	3. RECIPIENT'S CATALOG NUMBER
4. TITLE (and Subtitle) DEEP-TOWED GEOPHYSICAL ARRAY SYSTEM Development Program Review	5. TYPE OF REPORT & PERIOD COVERED	
	6. PERFORMING ORG. REPORT NUMBER	
7. AUTHOR(s) Martin G. Fagot            George J. Moss Norman H. Gholson        Darrell A. Milburn	8. CONTRACT OR GRANT NUMBER(s)	
9. PERFORMING ORGANIZATION NAME AND ADDRESS Naval Ocean Research and Development Activity Ocean Technology Division NSTL Station, Mississippi 39529	10. PROGRAM ELEMENT, PROJECT, TASK AREA & WORK UNIT NUMBERS	
11. CONTROLLING OFFICE NAME AND ADDRESS  Same as above	12. REPORT DATE June 1980	
	13. NUMBER OF PAGES 75	
14. MONITORING AGENCY NAME & ADDRESS (if different from Controlling Office)	15. SECURITY CLASS. (of this report)  UNCLASSIFIED	
	15a. DECLASSIFICATION/DOWNGRADING SCHEDULE	
16. DISTRIBUTION STATEMENT (of this Report)  Unlimited		
17. DISTRIBUTION STATEMENT (of the abstract entered in Block 20, if different from Report)		
18. SUPPLEMENTARY NOTES		
19. KEY WORDS (Continue on reverse side if necessary and identify by block number) Multi-channel array            Seismic streamer Low frequency sound source    Seismic profiling Deep-towed system                Seismic data processing Geophysical parameters          Telemetry communications		
20. ABSTRACT (Continue on reverse side if necessary and identify by block number) A program has been initiated to develop a deep-towed system consisting of a low frequency sound source, hydrophone array, communication and data recording system, and data processing capability for measuring in the deep ocean (6000 m depth) the detailed spatial variability of the geological, geophysical, and geacoustic parameters of the ocean floor and first 500 m of subbottom structure. This high resolution data set will allow computing definitive geacoustic model input parameters for performance prediction of naval fleet systems with acoustic bottom interaction. The technology developments of this		

DD FORM 1 JAN 73 1473

EDITION OF 1 NOV 68 IS OBSOLETE  
S/N 0102-LF-014-6601

UNCLASSIFIED

SECURITY CLASSIFICATION OF THIS PAGE (When Data Entered)

*5th page*

UNCLASSIFIED

SECURITY CLASSIFICATION OF THIS PAGE (When Data Entered)

program will provide both the Navy and the marine science and technology communities with a new deep-ocean measurement capability.

Performance studies show an order of magnitude improvement in geoacoustic parameter determination and spatial resolution for the deep-towed system over conventional surface-towed systems operating in deep water. System configuration trade-offs, optimized for compressional wave speed measurement precision, have been performed utilizing a statistical error approach. This approach provides quantitative error prediction for such varying system parameters as array length, offset (sound source to array distance), group spacing (hydrophone separation), and system tow altitude based on statistical variance of reflection energy arrival times.

Hardware parameter characterization studies have identified technology development areas and critical system parameters required to meet the scientific deep-ocean measurement goals. A Helmholtz resonator transducer and a hydroacoustic impulse device have been identified as two approaches for sound generation in a deep-towed configuration. The more acoustically optimum impulse device has a projected acoustic spectral level of  $172 \text{ dB/upa} \cdot \text{sec}^2/\text{Hz}$  over 200 Hz to 700 Hz band, and a peak source level of  $224 \text{ dB/upa}$  @ 1 m. The initial design parameters for the deep-towed array are 1000 m long, 40 m offset, 40 m group spacing, and 25 hydrophone channels. Communications with the towed system will employ a digital time division multiplex approach with 27 high data rate acoustic channels and 23 low data rate engineering sensor channels. The navigation suit will employ a deep-towed doppler navigator and a ship-interrogated short base line navigation system. This suit allows firing the sound source at fixed distances along track and positioning the sound source/array relative to the tow ship. A unique data processing approach to extract the geoacoustic parameters employing the nonhyperbolic moveout of the deep-towed data set has been initially tested through performance prediction simulations.

Hardware fabrication will be initiated in late 1980 with extensive subsystem testing throughout the development cycle. A total system test emphasizing definitive performance evaluation is planned for 1984.

This technical note presents slide material with text that was used in a presentation to management for reviewing program objectives, projected system scientific and technical capabilities, system performance predictions, basic hardware characteristics, data processing requirements, and plans outlining total system hardware development.

UNCLASSIFIED

SECURITY CLASSIFICATION OF THIS PAGE (When Data Entered)

