

AD-A091 072

FOREIGN TECHNOLOGY DIV WRIGHT-PATTERSON AFB OH  
ENCAPSULATION OF ELECTRONIC SUBASSEMBLIES WITH THERMOSETTING RE--ETC(U)  
SEP 80 P ROZDZIAL

F/G 9/1

UNCLASSIFIED

FTD-ID(RS)T-1150-80

NL

1 of 1

AD-A091 072



END  
DATE  
FILMED  
11-80  
DTIC

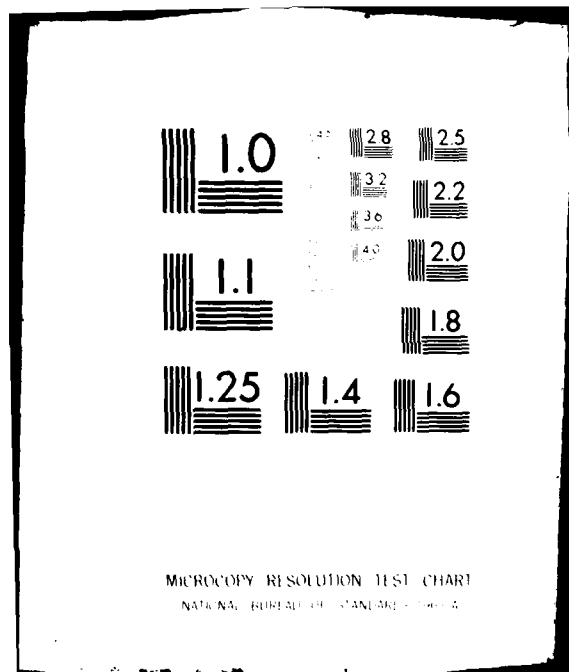

AD A091072

FTD-ID(RS)T-1150-80

4  
B.S

FOREIGN TECHNOLOGY DIVISION



ENCAPSULATION OF ELECTRONIC SUBASSEMBLIES  
WITH THERMOSETTING RESINS  
PART II. PRESSURE INJECTION WITH LIQUID RESINS

by

Pawel Rozdzial

OPTIC  
ELECTE  
OCT 31 1980  
S D  
E



DDC FILE COPY

Approved for public release;  
distribution unlimited.



80 10 29 116

# EDITED TRANSLATION

14

FTD-ID(RS)T-1150-80

11

19 Sept 1980

MICROFICHE NR: FTD-80-C-001027

6

ENCAPSULATION OF ELECTRONIC SUBASSEMBLIES WITH THERMOSETTING RESINS. PART II. PRESSURE INJECTION WITH LIQUID RESINS

12 22

By Pawel Rozdzial

English pages: 20

Source: Edited Trans. of Polimery Tworzywa Wielkocząteczkowe ml2 1974 pp. 627-631

(Poland)

Country of origin: Poland

Translated by: SCITRAN F33657-78-D-0619

Requester: FTD/TQTR

Approved for public release; distribution unlimited.

Accession For	
NTIS GRA&I	<input checked="" type="checkbox"/>
DDC TAB	<input type="checkbox"/>
Unannounced	<input type="checkbox"/>
Justification	
By	
Distribution/	
Availability Codes	
Dist.	Avail and/or special
A	

See also Part 1, AD-091 071.

THIS TRANSLATION IS A RENDITION OF THE ORIGINAL FOREIGN TEXT WITHOUT ANY ANALYTICAL OR EDITORIAL COMMENT. STATEMENTS OR THEORIES ADVOCATED OR IMPLIED ARE THOSE OF THE SOURCE AND DO NOT NECESSARILY REFLECT THE POSITION OR OPINION OF THE FOREIGN TECHNOLOGY DIVISION.	PREPARED BY: TRANSLATION DIVISION FOREIGN TECHNOLOGY DIVISION WP-AFB, OHIO.
--	--

142600

AB

ENCAPSULATION OF ELECTRONIC SUBASSEMBLIES  
WITH THERMOSETTING RESINS

part II. pressure injection with liquid resins

Pawel Rozdzial

Attempts are now being made to utilize both the advantages of encapsulation processes by pouring with liquid resins and large outputs obtainable in pressure molding - by combining them in one process of "pressure injection with liquid compositions."

Truly speaking, the new method has no chance of eliminating the both mentioned processes, but it forms an excellent bridge between them. It enables to apply larger number of compositions than in encapsulation by pressure molding. When liquid resins are pressed, the applied pressure is considerably smaller, 1-35 kg/cm<sup>2</sup>, and on heating it falls even to 0.3 kg/cm<sup>2</sup>, which enables to treat particularly fragile and mechanically sensitive subassemblies. In contrast to moldings, the compositions contain no lubricating agents. For this reason, resin has better adhesion to leads and subassemblies, and thus there is better tightness of encapsulation and better protection against the penetration of moisture. It has also to be added that the costs of these compositions are lower than the costs of moldings.

The process consists of injection of liquid composition into a multi-nerst form compressed in the press under relatively small pressure. Depending on properties of the composition, and

particularly its pot life, the ready composition is supplied either directly from a large tank providing it to the form (Figure 12), or from a measuring tank with mixer, in which there is dosing and mixing of appropriate portions of components directly before each injection (Figure 12).

The production cycle in the press for injection pressing is as follows. The subassemblies to be encapsulated are placed in nests of the form, and the press is turned on either directly or by means of a loading ram. This causes an automatic closing of the form and forces into it through the injection nozzle the whole premeasured amount of the composition. The resin begins immediately to harden in the preheated form. The injection nozzle has to be cooled to prevent hardening of the composition before the pressing. After hardening of the resin, the form opens, the pressed subassemblies become ejected, and a new portion of composition is dosed into the injection cylinder. From time to time the injection system and the form have to be washed with solvent. Since the pressure of injection is low, the pressure to close the form is also low, hence we can employ presses of less than half the force than in the molding pressing.

Instead of presses used in molding one can use here simpler presses for piston pressing. The requirements concerning the closely controlled speed of closing the form - different in the first stage of closing, and different at the time of tightening - and the pressures applied, are the same as in molding pressing.

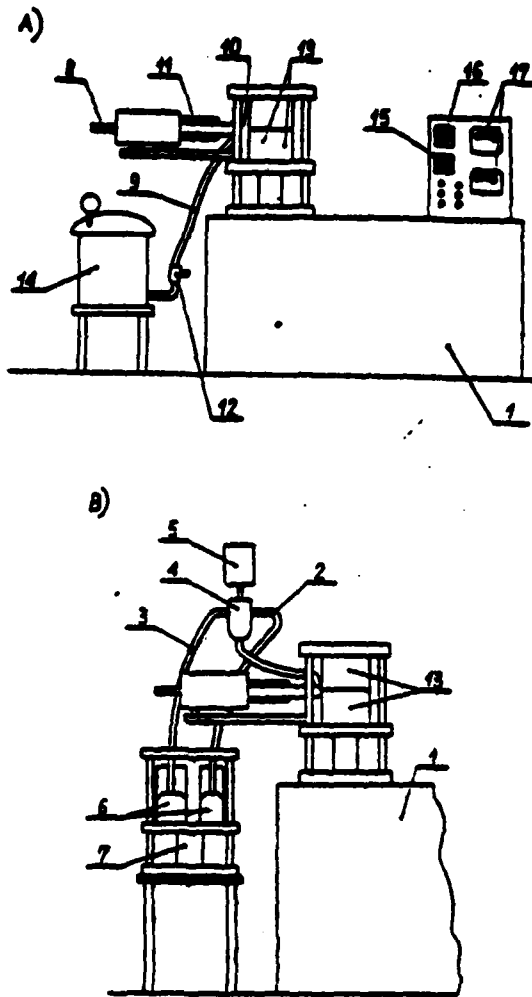

- Figure 12. system for pressure injection with liquid compositions:  
A) with tank containing ready composition; B) with facilities for  
measuring out the components;

- 1 - press; 2 - supply of hardener; 3 - supply of resin;
- 4 - chamber of mixer; 5 - motor of mixer; 6 - cylinders dosing  
(measuring out) resin and hardener; 7 - moving cylinder;
- 8 - injection volume regulator; 9 - supply connection;
- 10 - nozzle; 11 - injection cylinder with water jacket;
- 12 - automatic valve; 13 - form; 14 - composition cylinder  
under pressure; 15 - regulation of injection time; 16 - regu-  
lation of hardening time; 17 - regulation of temperature.

However, with appropriate choice of composition and parameters of injection and hardening, the time of pressing may be considerably shorter. In total then, the cost of presses may be lower while the output - larger.

However, the press requires an additional system for measuring out, mixing and injection of composition. For this purpose, one can adapt typical systems for automatic or semi-automatic pouring with liquid resins. The tank with ready composition and the mixing-supplying system should be fitted with facilities both for cooling and for heating. It widens considerably the choice of compositions and enables to use materials with various pot life. A simple injection system is served with special pump; also, a system of molding pressing used for low-pressure materials can be employed here.

The dosing (measuring out) chamber should enable to 628 measure doses (portions) and the injection chamber should have facilities for heating up the composition. This heating shortens the time of hardening and also reduces the viscosity of composition. The injection system should be easy to disassemble in cases of the emergency stoppage of press when the resin hardens in the cylinder.

It can be expected that new presses designed for electronic industry will be built in such a way that they would be suitable for encapsulations with either moldings or liquid resins. The forms for encapsulation should have their surface

hardened, because of the ease of damage by improper placing of leads. On the whole, principles concerning the construction of forms for molding pressing continue to apply, with reservation that, in view of greater variety of properties of used compositions, some details - such as vacuum degassing or placement of ejectors- should be adaptable to individual compositions.

The injection takes place at the line of division of form; the form has no pour container or push cylinder, and the cross-section of channels is smaller so that there is no need to use narrowing strips. Dimensional tolerances should be stricter than in the mold pressing - it gives, however, an advantage of smaller outflows, and sometimes their total elimination.

When prototype parts are made or the production is on a small scale so that single-nest forms are needed, the setup may be particularly simple and inexpensive. For instance, the forms may be made of epoxy resin, and manual press can be used for injections.

All compositions based on resins used in the technology of pouring may be used for pressing; they include epoxy, silicon, polyester and allylic resins.

In addition to a resin and hardener, the compositions may also contain catalysts, mineral fillers, plasticizers, pigments, fibers, etc. On one hand, they should provide a good climatic protection, resistance to mechanical damage, and reliability; on the other hand, their choice should facilitate

the process of encapsulation and lower its labor-consumption and costs. The flexibility of the process is here considerably higher than in the case of molding, but it requires also greater inventiveness on the part of the technologist and the designer of subassembly.

When selecting the parameters of composition one should be guided by the following remarks:

- The viscosity of used compositions should be more than 100,000 up to maximum 750,000 cp. The heating of components before mixing enables to degas and lower the viscosity of composition. The heating of the ready composition facilitates the injection. After the composition enters the form the viscosity is smaller, which enables to fill up all the gaps.

- The content of filler should not exceed 70%. A larger content is permissible when there is possibility of considerable reduction of viscosity by preliminary heating up of composition. All the fillers used in compositions for pouring can be employed here, hence the choice is larger than in the case of molding.

- The length of cycle depends to a large extent on the gelling time of the composition. If we use pre-mixed compositions their life time must last several hours, so that the cycle can be extended. When we have dosing and mixing before each injection, it is possible to use compositions with gelling time 15 seconds, and to shorten the cycle to 30 seconds (at the temperature 150°C).

- An additional hardening is necessary after removal of pressed subassemblies from the form; it takes usually 10-24 hours

at the temperature 120-150 °C.

Encapsulation with powders - fluidization method and its derivatives

slowly but systematically the technology of covering the subassemblies with powders is finding broader and broader application. The main reason is that one uses then ready composition containing already hardeners so that one avoids the inconvenience of weighing, mixing and degasing of a small amount of liquid components. Another certain advantage of this method is the possibility of covering various kinds of subassemblies with one and the same setup, without the necessity of making special adaptations for each of them. The cost of encapsulation by fluidization method amounts on the whole to about 1/3 of the cost of mold pressing.

Among various powders, epoxy compositions are mainly used for encapsulation.

The optimal coverage of subassemblies is obtained when the powder occupies 25-33% of the volume of fluidized cloud and there are no phenomena of turbulence and geysers, while the subassembly is subjected to vibration. The diameter of the grains of powder should be in the range 40-1000 <sup>μm</sup> μm. The role of particular fractions of the grains of powder is of importance. Smaller grains melt faster and form a smoother but thinner coating. Larger grains give a thicker but rougher coating and require heating to a higher temperature and a more intense stream of air which, in turn, is a cooling factor and requires further increase of the temperature of subassemblies. At a proper ratio of thick to thin grains,

not only can one lower the stream of air, but also reduce the temperature of subassembly, and still obtain a thicker coating. A longer time of immersion leads to a thicker coating, but worsens the quality of this coating because of the cooling of subassembly. As a rule, therefore, the treatment is done several times at short times of immersion. After each removal of subassembly from the powder cloud, the subassembly is heated again. After single immersion, the thickness of layer is 0.2-0.8 mm. Multiple immersions can provide even a layer of several mm. After removal from the fluidizing bath the subassembly with deposited coating is placed in a dryer at 120-240 °C for 10-30 minutes to effect the complete hardening of the resin.

The obtained coatings can work in the range from -55 to -150 °C, have resistance up to  $10^{16} \Omega$  cm, dielectric strength 20-40 kv/mm,  $\text{tg} \delta = 0.005 - 0.015$ ;  $\epsilon_r = 3.5-4.5$ . Subassemblies covered by fluidization pass 21-day moisture test. The main difficulty in the initial period of introduction of this method was the covering of small subassemblies with low heat capacity. These subassemblies cooled down before the powder managed to cover them fully and to melt. Hence the method was used mainly to cover stands and rotors, and motors of fractional power, and to considerably lower degree in the area of printed circuits.

Only the appearance of automatic machines with programmed cycles, enabling the quick loading and immediate immersion in fluidizing bath after preheating of several tens of subassemblies, enabled to apply this technology to mass

covering of even very small subassemblies, such as tantalum condensers.

Several tens of subassemblies prepared for covering are glued through their leads one near another by means of glueing tape to a band of cardboard, plastic, or metal sheet and are placed in the clamps of the machine. The machine does the rest; it carries the process of encapsulation according to the pre-set programmed cycle. This program provides optimal conditions for the time of heating, temperature, immersion time, number of immersions, and other parameters of the process.

In the first stage, the clamp places the subassemblies in the heating zone (15 secs - hot air), and then immerses them in fluidizing bath for 0.5 sec, takes them out and heats them again for about 3 seconds to integrate the coating. The cycle is repeated three times and then the subassemblies together with band are placed in the dryer. The hanging on the lead is kept in such a way that the length of subassembly lies within the tolerance limit  $\pm 0.75$  mm. Figure 13 shows the course of changes of temperature for a thick-layer encapsulated microelectronic circuit during the covering. The measurements were done by means of a thermistor mounted in the circuit. As is seen, the time at which the subassembly is exposed to temperature  $> 120^{\circ}\text{C}$  is so short that it should not have negative effect even on subassemblies sensitive to this temperature. The cycle proceeds automatically and one of the conditions of success, aside from the speed of immersion, is the accuracy of mounting and placing

629

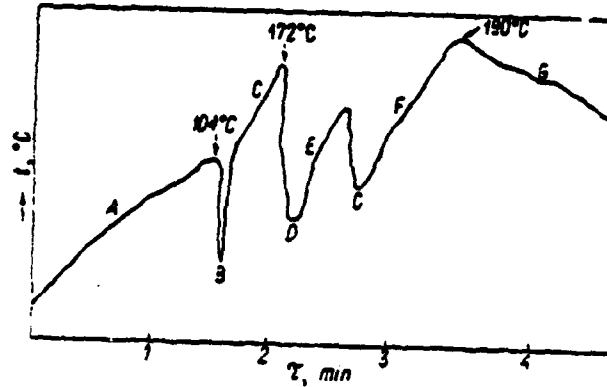

Figure 13. Course of changes of the temperature on surface of a microelectronic circuit being covered by fluidization method.

subassemblies preheated to a constant temperature into fluidizing bath, and maintaining the constant level of that bath. The automatic machines for fluidization, produced currently, enable to cover in one hour from 1500 subassemblies of dimensions 18 x 32 mm to 30,000 of dimensions 3 x 3 mm.

So far, the most satisfactory solutions of design for automatic machines have been achieved for subassemblies with one-side leads. In the case of two-side leads it is difficult to prevent the leads to be covered. Also, difficulties are encountered in encapsulation of rolled condensers from plastics because of the evolution of air from the roll which leads to the occurrence of bubbles. In such cases, the assemblies have to be previously impregnated to expel the air from the gaps.

Similar problems may arise in hybrid circuits containing very narrow gaps. This time, however, we can avoid getting bubbles

even if the gaps are not filled with resin, but only if a bridge is put across them. When covering hybrid circuits containing elements from various materials, the resistance to temperature shock - sudden changes from negative to positive - is very important since these changes may cause the rupture of either the circuit or the coating.

The following principles have to be observed to obtain coatings of maximal resistance:

- the coating on both sides of the circuit should reach the leads in the same way, forming uniform meniscus and not leaving any uncovered edge of the base plate;

- the coating should not form bridges joining only two or three leads - it is harmless to bridge all the leads;

- thickening of the coating from the edge to the middle at the thickness of base 0.75 mm and total thickness 2.8 mm should not exceed 17%;

- the optimal total thickness of coating on thin bases is 1.5 - 2.5 mm.

One of the conditions for effectiveness of encapsulation at elevated temperature is high glass temperature ( $T_g$ ) of encapsulating resin. The Table that follows gives data pertaining to the value of  $T_g$  as a function of the time of additional hardening at various temperatures, after the coverage with an epoxy-novolak powder polyset B:

	100°C	125°C	150°C	175°C
15 min	—	—	142	154
30 min	—	—	145	149
1 h	132	138	151	148
2 h	134	141	147	—
4 h	137	137	148	—

We can see that, on one hand, the value of  $T_g$  increases with increase of the temperature; on the other hand, for each temperature there is an optimal time of hardening. The discussed powder enables to attain  $T_g = 150^\circ\text{C}$ , hence a value by  $35^\circ\text{C}$  higher than for usual epoxy resins. Before covering, spools may be resistance heated, by passing current through them.

In order to cover subassemblies with axial leads we can use the cascade method (Figure 14) in which the powder is falling from a vibrating incline onto subassemblies moving on a transporter belt and themselves rotating. The leads are masked with metal tape or with a stream of air.

For some subassemblies the preliminary preheating is not desirable (e.g., Cu surface). It can be avoided using the fluidizing bath with electrostatic field. In this bath, under the surface of fluidizing powder there is a net with connected high potential of the order of 10-160 kV (Figure 15). This net (grid) imparts high velocity to particles, and the grounded subassemblies

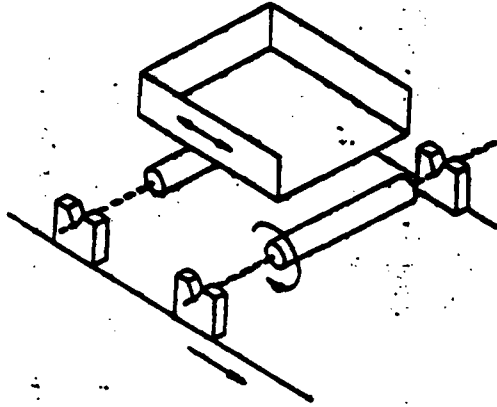

Figure 14. Coating of subassemblies with fluidizing powder by the cascade method.

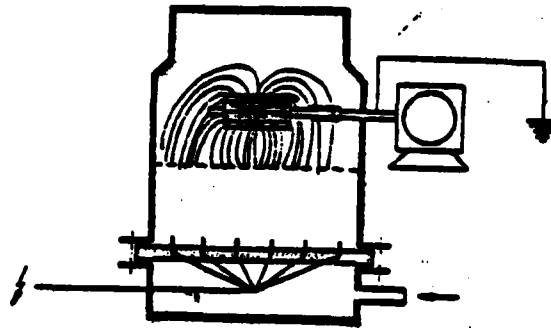

Figure 15. Fluidization with participation of electrostatic field.

attract the particles of powder. The powder-covered subassemblies are placed in a dryer to effect the melting and hardening of the coating. Uniform layers of thickness 25-400 ~~µm~~<sup>µm</sup> are obtained. The leads may be protected by means of insulation tubing, which is removed before placing the subassemblies in the dryer.

Parts with large dimensions, such as toroidal cores, transformers, etc., may be covered with powder in various ways by the method of simple or electrostatic spraying.

#### Encapsulation by the E-PAK method.

A technology called E-PAK has been developed to avoid difficulties connected with weighing and mixing of components and measuring out small amounts of liquid compositions. This technology is based on the use of compositions from constant components supplied in the form of lozenges of desired shape. The lozenge together with subassembly is placed in a cup, tube or on a base plate (Figure 16) and the whole set is placed in a dryer. There follow the melting and covering of the subassembly, and then the hardening and encapsulation. The lozenges may have various geometrical shapes (e.g., with openings for leads) and different degrees of thixotropy after melting so that they do not drain from the subassembly.

#### Encapsulation by the method of dipping.

The encapsulation technology by the method of dipping in liquid resin or suspension, or the so called cocoon wrapping,

630

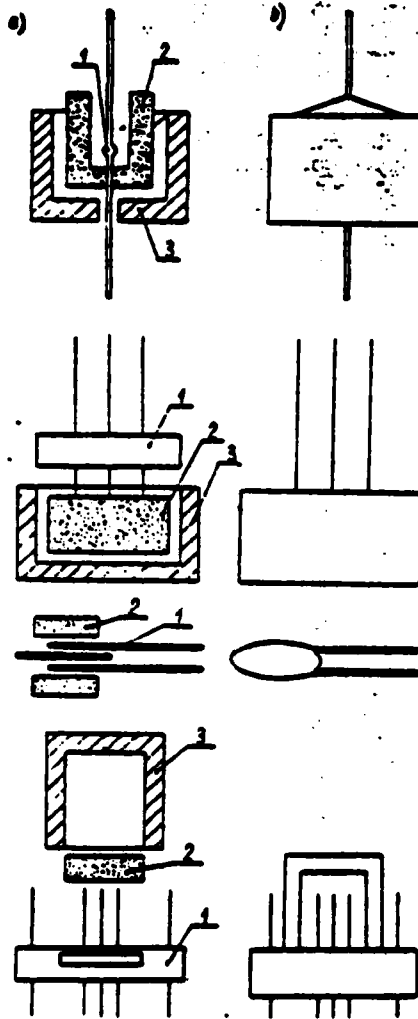

Figure 16. Encapsulation by the E-PAK method:  
a) before encapsulation; b) after encapsulation  
1 - subassembly; 2 - E-PAK tablet; 3 - cup.

is the broadly used way of protecting the subassemblies intended to be employed in equipment of everyday use.

This technology is particularly suitable for large-scale production. Apart from a special bath and mixer, and a facility for immersing subassemblies and a dryer, no special individual facility is required for particular subassembly. The method enables to effect encapsulation of 10,000 - 20,000 subassemblies per hour. It is the most broadly used for encapsulation of ceramic, tantalum and mica condensers and for thick-layer microelectronic circuits.

The condition for success of the discussed technology is proper construction for facility in which the dipping takes place. This arrangement should enable mixing or motion of the resin, programmed speed of immersion and emergence of subassemblies, and their vibration after the immersion; proper choice of these parameters permits to obtain a homogeneous uniform layer, without drips.

The method of dipping employs largely epoxy, phenolic and silicon resins, the phenolic resins being predominant.

Two specific resins are used primarily for encapsulation: Durez 9341 and Durez 16382 (Hooker Chemicals). They are compositions containing 50% resin and 50% inorganic filler ( $MgCO_3$ ) and they differ in their reactivity. By using them together in different ratios one can modify properties of the composition.

The resin is dissolved in a mixture of ethyl alcohol, butyl alcohol and acetone. To the suspension obtained this way 2-5 % water is added to reduce the tendency to form drips. Before

use the suspension is mixed intensively and homogenized. In turn, it is poured into a round bathtub with cooling water jacket and mixer with several tens revolutions per minute. The process of dipping of subassemblies takes place in this tub. During the whole process of encapsulation the viscosity is controlled by means of Brookfield viscosimeters (50-75°). When the viscosity increases, a solvent, e.g. butyl alcohol, is added to suspension. When the viscosity is too small, the velocity speed of mixer is increased for some time, causing evaporation of the excess of solvent.

The subassemblies which are being encapsulated are glued on tapes, just as it is done in encapsulation by fluidization method. Before the coating, the subassemblies are degreased in "tri", only if their chemical resistance allows to do so. The tapes are placed in a hold (clamp) located above the bath. Next, either the tapes are lowered down slowly into the resin or the bath with resin is raised at predetermined speed and stops when the upper edge of the dipped subassembly becomes equal with the level of resin in the bath (Figure 17).

Subsequent lowering of bath or pulling out the subassemblies from the resin must be done also slowly at programmed speed. The step of removal is repeated several times until the resin does not stop flowing from subassembly when being removed. During the whole process of dipping and removal the tape with subassembly is subjected to vibration to facilitate removal of bubbles from resin. In order to obtain an appropriate

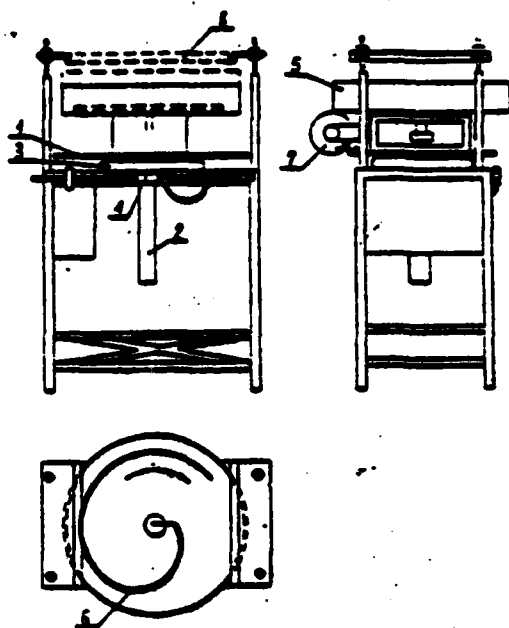

Figure 17. Arrangement for encapsulation by the method of dipping. 1 - moving plate; 2 - leader; 3 - pneumatic cushion; 4 - valve; 5 - container with resin; 6 - mixer of resin; 7 - reducer of revolutions; 8 - hold (clamp) for attaching the subassemblies.

thickness and uniformity of layer (0.2 - 0.8 mm), not containing bubbles, the dipping is repeated several times, at intervals of several minutes, and then the dipped subassemblies are dried for 12-48 hours to remove the solvent. After single immersion the time of drying in air may be shortened to 60 minutes by raising the drying temperature to 65 °C.

1631

The dried resin covering subassemblies is now hardened at a temperature depending on thermal resistance of these subassemblies. This temperature should not be lower than 120 °C; it should be raised gradually, and the time of hardening is 2 - 10 hours. If subassemblies allow to do so, the hardening is carried out at the temperature 160-180 °C for one hour. Coatings from a phenolic resin of purez type are intended to be used in the temperature range -55 to +85 °C. The practice has shown, however, that even after 1000 hours of work at the temperature 150 °C one observes only some darkening of the natural light-brown color.

The coatings may be stained by adding to the dissolved resin 0.25-2 % of dyes soluble in alcohol (fatty dyes, nigroline).

The coating obtained after hardening is porous. Therefore, in order to increase its resistance to moisture, it is necessary to impregnate it (by vacuum method), using low-viscosity epoxy resins or synthetic waxes.

REFERENCES

1. Reish B., Haxim B.: Solid State Technology 1971, nr 1, 68.
2. Harper Ch. A.: „Handbook of Materials and Processing for Electronics”. Mc Graw Hill, New York 1972.
3. Kainle J. P.: „Plastics for Semiconductor Encapsulation”. 20th Annual Technical Conference 6-10 May 1969; t. XIV, s. 702.
4. Debon G.: Electronic Eng. 1971, nr 1, 67.
5. Licari J. J., Browning G. V.: Elektronika 1967, nr 7, 162.
6. Moss E. D.: Proc. IEEE 1969, nr 2, 169.
7. Gilberg R. C.: J. Electrochem. Soc. 1971, nr 1, 129.
8. Rozdział P.: „Tworzywa sztuczne w elektronice”. WNT, Warszawa 1971.
9. Rozdział P.: Postępy Telekomunikacji 1968, nr 4, 2.
10. Hannay M. E.: „Półprzewodnik” WNT, Warszawa 1968.
11. Nowacki J., Szyszej K.: Elektronika 1968, nr 12, 62.

8. Rozdział: plastics in electronics

9. Rozdział: progress in telecommunication

10. Hannay: semiconductor

11. Nowacki, szyszej: Electronics.