

AD-A091 226

SCIENCE APPLICATIONS INC EL SEGUNDO CALIF  
SPACECRAFT CHARGING MODEL VALIDATION/TEST EVALUATION STATUS REP--ETC(U)  
SEP 80 E E O'DONNELL F04701-80-C-0009

F/G 22/2

NL

UNCLASSIFIED



END  
DATE  
FILMED  
12-80  
DTIC

LEVEL



AD A091226

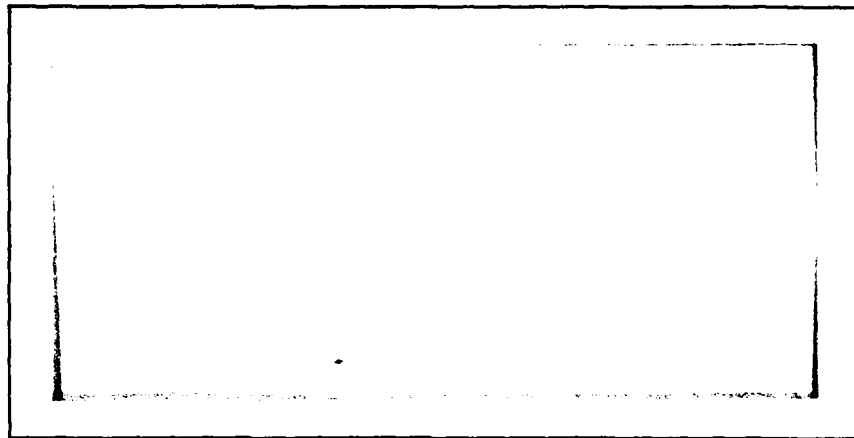

SCIENCE  
APPLICATIONS  
INCORPORATED

NOV 3 1980

DOC FILE COPY

DISTRIBUTION STATEMENT A  
Approved for public release;  
Distribution Unlimited

80 9 26 006

19 September 1980



LAC-171E-81-064

**SUBJECT:** SCATHA Data and Modeling Analysis  
Contract No. F04701-80-C-0009  
Model Validation/Test Evaluation Status Report  
CDRL A009

**TO:** Maj. J. Roberts (SD/YLVS)  
Air Force Space Division  
P.O. Box 92960  
Worldway Postal Center  
Los Angeles, CA 90009

1. Enclosed is the SCATHA Model Validation/Test Evaluation Status Report, CDRL A009, in compliance with the subject contract. Questions should be directed to Ed O'Donnell at SAI.

Sincerely yours,

SCIENCE APPLICATIONS, INC.

A handwritten signature in cursive script, appearing to read 'Alan B. Holman'.

Alan B. Holman

ABH/bke

Enclosure

xc: N. Covey (w/o enclosure)  
E. Hack (w/o enclosure)  
SD/YLVS (2 copies)  
SD/YLT  
R. Broussard (Aerospace Corp - 3 copies)  
SD/PMTS-1 (w/o enclosure)  
**DTIC**  
**AUL**

Science Applications, Inc. 101 Continental Bldg., Suite 310, El Segundo, California 90245 · (213) 640-0480

Other SAI Offices: Albuquerque, Ann Arbor, Arlington, Atlanta, Boston, Chicago, Huntsville, La Jolla, Los Angeles, McLean, Palo Alto, Santa Barbara, Sunnyvale, and Tucson

①

⑥  
SPACECRAFT CHARGING  
MODEL VALIDATION/TEST EVALUATION  
STATUS REPORT

CDRL A009

⑪ 11 Sep 78

⑬ 38

11 SEPTEMBER 1980

⑬ F04701-80-C-0009

SUBMITTED TO:

DEPARTMENT OF THE AIR FORCE  
HQ SPACE DIVISION  
LOS ANGELES AIR FORCE STATION  
LOS ANGELES, CALIFORNIA

PREPARED BY:

⑩ EDWARD E. O'DONNELL

DISTRIBUTION STATEMENT A  
Approved for public release  
Distribution unlimited

407842

alt

SPACECRAFT CHARGING  
MODEL VALIDATION/TEST EVALUATION STATUS REPORT  
CDRL A009

1.0 INTRODUCTION

One of the primary objectives of the cooperative NASA/Air Force Spacecraft Charging Investigation is to ensure that validated analytical models and test techniques are available for the assessment of spacecraft interactions with the space environment. Historically, the modeling activity has been divided into four regions:

- The undisturbed environment
- The plasma sheath surrounding the spacecraft
- The spacecraft surface
- The spacecraft interior

Models must be capable of predicting the degradation (permanent damage or anomalous behavior) of spacecraft due to the environment. Also, test techniques must be developed for the purposes of providing input data for the models, or for certifying that the spacecraft fulfills its design requirements.

This report is an update to the Model Validation/Test Evaluation Status Report (CDRL 006A2) submitted August 1979 by SAI. Since the previous report a number of significant developments have occurred, and plans for additional tests and analyses have been made.

In the past year, P78-2 data have been integrated into an environmental Atlas. NASCAP predictions have been compared with the P78-2 SSPM sample measurements. Two major electron spraying experiments have been conducted on geometric spacecraft

models for which coupling predictions have been made. A quasi-static model of the SGEMP code SABER has been developed and exercised, and significant work has been reported on the emission of current during discharges. Also, P78-2 internal coupling data have been compared with predictions based upon ground test data and discharge models.

These developments, and others, will be described more fully in the following sections.

## 2.0 ANALYTICAL MODELS

In order to be able to predict the interaction of a spacecraft with the charged particle environment, analytical models must be employed. These models consist of an environmental model, a plasma sheath model which can predict spacecraft surface potentials, discharge models describing the electrical characteristics of the discharge, and coupling models to predict the electrical response of the spacecraft and the electromagnetic interference associated with discharges.

The status of analytical models is discussed below. Figure 1 presents a schedule of the model validation activities through October 1981.

## 2.1 ENVIRONMENTAL MODELS

Using data from P78-2, the Air Force Geophysics Laboratory (AFGL) has published a preliminary environmental Atlas. [1] This document is limited by the availability of data; both SC-5 and SC-9 data were available only for a total of 44 days. Unfortunately, the present version of the Atlas contains no data from charging events. However, a more complete version is in preparation, with a draft environmental Atlas expected to be complete by August 1981.

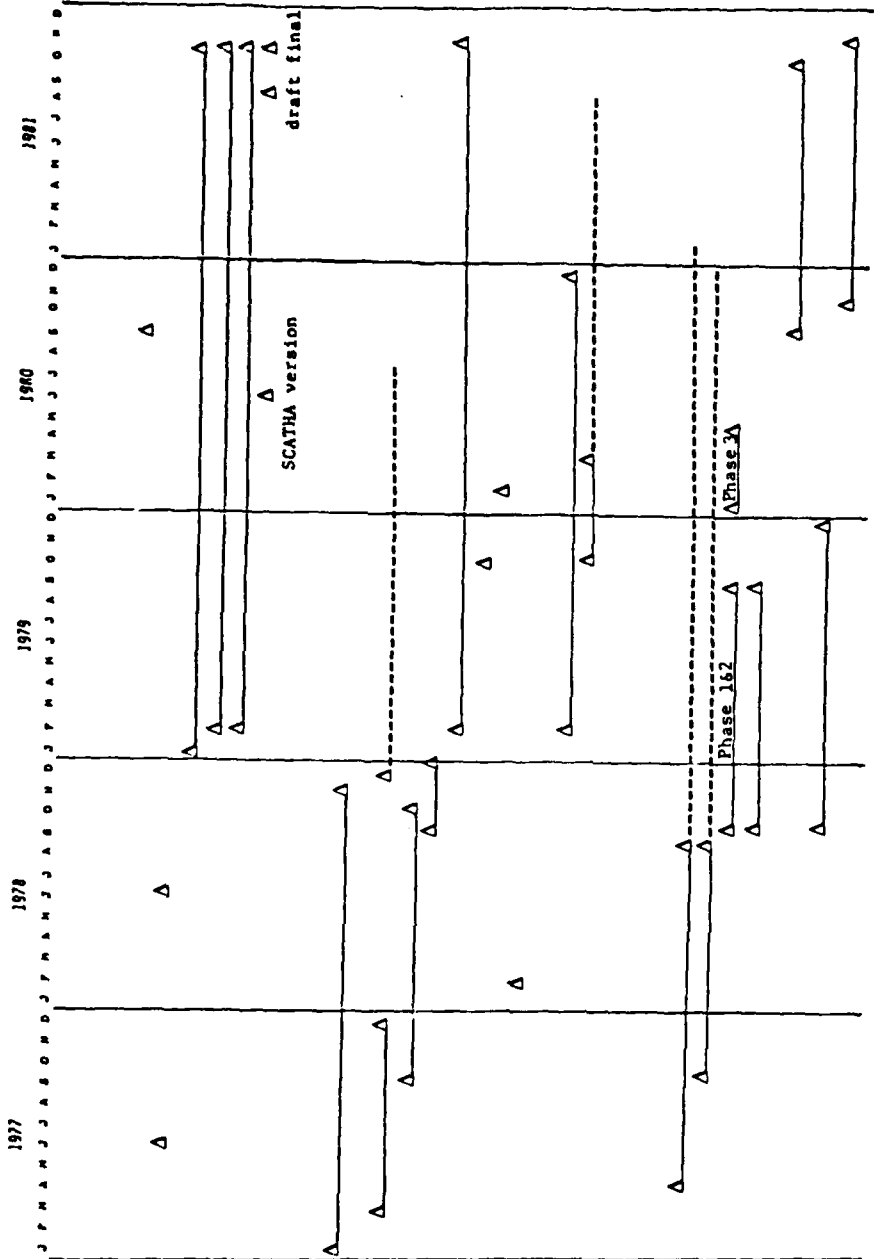

**ENVIRONMENTAL MODEL**  
 MAYA Preliminary Spec Aug 1976  
 NASA Provisional Spec Oct 1976  
 NASA Provisional Spec Update  
 SCATHA Data Requirements (AFGL)  
 SCATHA Operation  
 SCATHA Data Analysis (AFGL, Experimenters)  
 Daily Environmental Summaries  
 AFGL Atlas

**CHARGING MODEL**  
 NASCAP Development (S<sup>3</sup>)  
 NASCAP Workshops  
 Material Sample Tests (NASA LeRC)  
 SCATHA Charging Analysis (AFGL/S<sup>3</sup>)  
 NASCAP Extension  
 SCATHA Data Analysis (NASA LeRC, AFGL)  
 SCATHA Data Review (AFGL)  
 NASCAP - SSPH Comparisons (NASA LeRC)  
 Planar Charging Model (SAI)  
 Planar Model Development & Validation  
 (Parker/IM)  
 SCATHA Charging Analysis (S<sup>3</sup>)

**DISCHARGE MODEL**  
 AFOSR/SRI Experiments  
 NASA/IM Experiments  
 AFGL Experiments (IRT)  
 AFGL ECEMP Program  
 DNA Electron Spraying Tests (MRC)  
 University of Toronto Experiments  
 Electromagnetic Measurements (SRI)  
 Avalanche Discharge Model Development (SAI/BA)  
 Discharge Spec. for MIL-STD (SAI/BA)

Accession for	
MIL-STD	<input checked="" type="checkbox"/>
FIG 162	<input type="checkbox"/>
Unpublished	<input type="checkbox"/>
Justification	<input type="checkbox"/>
By	
Distribution	
Availability Codes	
Dist	

Figure 1. Model Validation Program Schedule

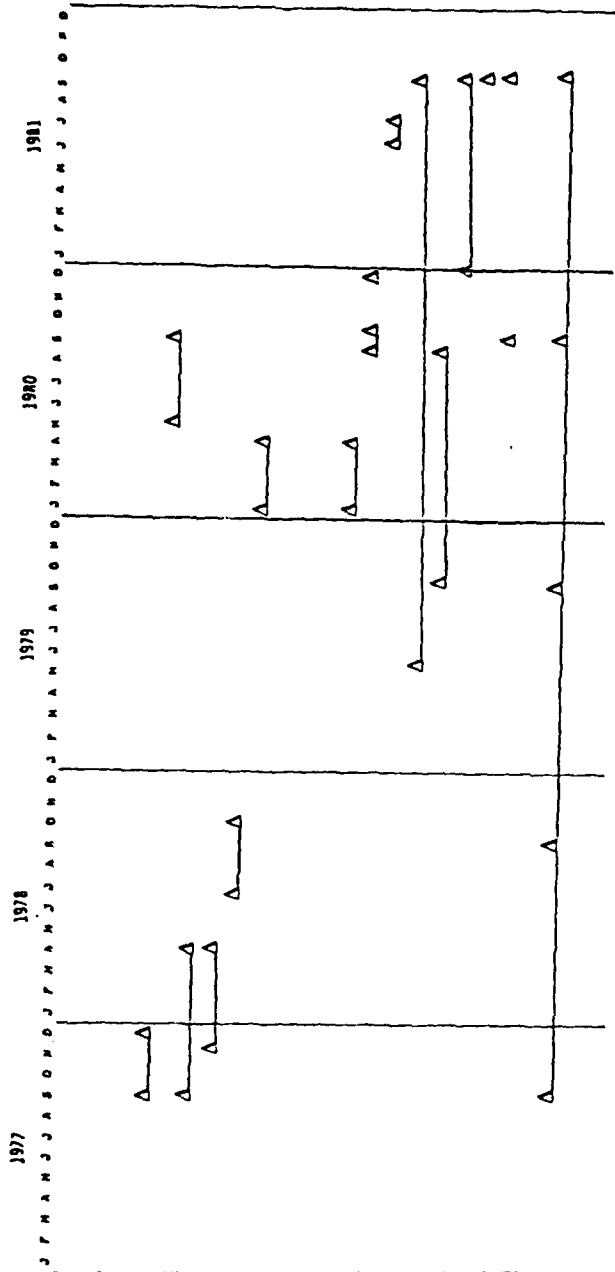

**COUPLING MODEL**

- SCEMP Code Conversion (IRT)
- Quasi-static Model (IRT)
- SCATSAT Coupling Analysis (IRT)
- SCATSAT Discharge Tests (IRT)
- SCATSAT Capacitive Drive Tests (IRT)
- ARORC Calculations (Jaycor)
- Electron Spraying Tests
- Skynet Test (MRC)
- CAN Test (IRT)
- AFVL Spraying Tests (CSS/Jaycor)
- SCATSAT Electron Test (IRT)
- FLTSATCOM Experiment
- SCATHA Data Analysis (SAI)
- SCATHA Immunity Margins (IRW)
- SCATSAT/SCATHA Data Comparisons (SAI/IRT)
- Validated Coupling Model (SAI/IRT)
- Test Specifications (IRT)

**MIL STANDARD Development (SAI)**

Figure 1. Model Validation Program Schedule (Cont'd)

## 2.2 SHEATH/CHARGING MODELS

Applications of the NASCAP code continued during the past year. Stevens, et al [2] compared NASCAP calculations of the P78-2 SSPM sample potentials to flight data and reported agreement to within 15%. This would appear to satisfy the requirements for validation of NASCAP. However, experiments reported by Treadaway, et al [3] appear to cast some doubt upon the validity of the SSPM measurements.

Schnuelle, et al [4] have performed detailed analyses of the charging of the P78-2 spacecraft in a variety of substorm conditions. They predict that the SCATHA booms are the most likely locations for discharges to occur. Also, calculations of the spacecraft potential for day 89 of 1979 (when the telemetry malfunction occurred) are presented, as well as a detailed study of gun operations.

In another paper, Stevens [5] extended NASCAP to model the effects of punchthrough and blowoff from discharges on spacecraft potential distributions. It is shown that large changes in the spacecraft potential will occur, subsequent to a discharge, with the result that adjacent dielectric surfaces can be expected to discharge. This coincides with observed "triggering" of discharges, once a given specimen has discharged.

Purvis [6] applied NASCAP to the study of spacecraft charging of sunlit surfaces. It was found that potential barriers formed by shaded dielectrics can inhibit photoelectron emission from lighted surfaces. Because of the slow charging rates, it was concluded that equilibrium conditions are not representative of true spacecraft charging response in a time-varying substorm.

The interaction of the plasma sheath with high voltage space power systems has been treated using NASCAP in two papers. Mandell, et al [7] compared the plasma power losses of a linear array to that of a modular array and concluded that the power loss differences were negligible. Stevens [8] used NASCAP to model the interaction of the space plasma with large, high voltage power systems. He concluded that the power losses were minimal (~1%) but that large electric field strengths could cause arcing in the dielectrics, which could cause difficulties in the proposed long lifetimes of the space power systems.

### 2.3 DISCHARGE MODELS

There has been a great deal of recent activity in the theoretical modeling of discharges, especially in the treatment of the blowoff charge. In addition to the theoretical work, a substantial amount of experimental data have become available.

When a charged dielectric surface exceeds the breakdown potential, an arc forms to a nearby conductor. It has been found that the arc is accompanied by an emission of some charge (usually 25% to 50% of the stored charge) from the dielectric surface. Data indicate that the duration of the charge emission (known as "blowoff") is the same as the duration of the arc. The exact nature of the blowoff charge and the manner in which it is released is not known.

Stettner and Marks [9] have investigated three models of the charge release: a uniform blowoff model, in which it is assumed that the charge appears uniformly above the surface; a moving region model in which the charge source is a ring propagating outward across the surface; and an edge model in which all charge is omitted at the edge. They conclude that, in the uniform emission and moving source models, space charge limiting will cause major deviations

from observed scaling laws (in which the blowoff charge is proportional to surface area) for sample sizes greater than 5 cm. Since this deviation has not been observed, they conclude that the source of charge must be at the edge of the sample.

A similar conclusion was reached by Katz, et al [10], who treated the dielectric as a space-charge limited cathode. They found that most of the emitted charge came from the edge of the sample.

It is generally accepted that a discharge, regardless of where it is initiated, propagates through conducting tracks formed just below the dielectric surface. Stettner and Dancz [11] solved for the time-dependent fields assuming the conducting track was a filament buried in a charged medium. Using this model, the late time current varied inversely proportional to time.

Inouye also considered the discharge propagation with the Brushfire model, which is documented in Reference 12. TRW's work concludes that  $G'$  (the ratio of blowoff current to arc current) may be as high as 58%.

Beers, et al [13] have performed calculations of the charging of Teflon and Kapton and the electromagnetic fields associated with discharges. The main conclusions regarding the electromagnetic field calculations are that space charge limiting can significantly affect the blowoff current, and that the presence of transverse fields will modify the functional behavior (e.g., inverse  $r$ , inverse  $r^2$ , etc.) of the fields.

Beers' calculations were performed to support the experimental measurements of Milligan, et al [14] at SRI, who measured electric and magnetic fields near the discharge source. Peak electric fields were on the order of 40 kV/m, varying inversely with  $r^3$ . It is important to realize that the fields are strongly dependent upon the blowoff charge motion, which is affected by the test geometry. Thus, the fields will be different in space than in the laboratory, and, indeed, will vary from location to location on the spacecraft.

Other discharge experimental programs of interest have been conducted by Balmain [15], Yadlowski [16], Mallon, et al [17], and Treadaway [3]. Balmain studied the dependence of the blowoff current upon incident electron flux for fluxes ranging from 0.8 to 100 nA/cm<sup>2</sup>. Kapton showed a consistent variation in peak blowoff current amplitude and released charge (both increase as flux increases), whereas no such relationship was observed for Teflon or Mylar. The pulse duration showed no dependence on flux, which is consistent with present models.

Yadlowski observed a pronounced anisotropy in Teflon, and noted two significantly different types of discharges, depending upon whether the grounding edge was parallel or perpendicular to the preferred direction of discharge propagation. The breakdown potential for perpendicular orientation was 10 to 14 kilovolts less than for parallel orientation. Energetic electrons were observed in both orientations, but no ions were observed for the perpendicular orientation.

The Jaycor experiments [17, 3] were performed under subcontract to Computer Sciences Corporation as part of the AFWL ECEMP (electron caused electromagnetic pulse) program. This program includes discharge characterization experiments for low and high energy electron irradiation, analytic modeling of coupling to spacecraft-like geometries, an electron spraying experiment of a simple geometry (cannister), and will include a system level electron spraying experiment of the FLTSATCOM (FSC) Qual Model. Discussions of the coupling and system test programs are described in later sections of this report.

Mallon, et al [17] exposed a simulated FSC solar panel to a combined high and low energy electron flux. Data are presented for blowoff charge. They observed that the presence of high energy electrons reduced the discharge amplitude, isolating the panel from tank ground through a high impedance reduced the discharge by a factor of 20 or more, and that the presence of UV eliminated discharges until the flux was increased.

Treadaway [3] performed a series of low flux experiments on FSC materials. The conclusions were that high energy electrons reduced or eliminated discharges from second surface mirrors. Discharges on FSC cables were observed for fluxes exceeding  $200 \text{ pA/cm}^2$ .

The Jaycor experiments also included exposure of the SSPM samples similar to those flown on P78-2. It was observed that the SSPM surface potential measurements were not affected by the presence of high energy electrons, a result which is inconsistent with previous results from the ECEMP program. Jaycor suspects that the discrepancy is due to the SSPM geometry and states: "We believe that the surface potential as measured by the SSPM is not in all cases a good indication of the sample surface potential.

The rate of change in surface potential as measured by the SSPM in the center of a sample will be approximately 1/12 that of the rest of the sample surface."

#### 2.4 COUPLING MODELS

The similarity between the discharge coupling problem and the nuclear SGEMP response has led to the application of computer codes developed for SGEMP to the discharge coupling problem. There were some difficulties to be overcome, primarily caused by the long discharge pulse duration (compared to the SGEMP source) which causes excessive computer time usage. This problem has been addressed by IRT [18] by adding a quasi-static algorithm to the SABER code. A similar approach has been used by Jaycor with the ABORC code [19].

As part of the AFWL ECEMP program, Jaycor performed a series of experiments in which simple geometric configurations with dielectric surfaces were exposed to electron irradiation. These experiments are described in References 20, 21, 22, and 23.

Figure 2 illustrates the test configuration, and Figure 3 shows the test object geometries. The object in Figure 3a is a cylindrical cannister with a dielectric surface on one end. It is instrumented with surface current probes (B) along the sides, and connected to tank ground through a variable resistance. In figure 3b, an object simulating an antenna and mast has been added.

The Jaycor ABORC calculations indicate that in the experimental configuration, charge emitted from the end dielectric surface swarms around the body, returning to the surface as late as several microseconds after the discharge begins. Jaycor has prepared a movie of the charge motion,

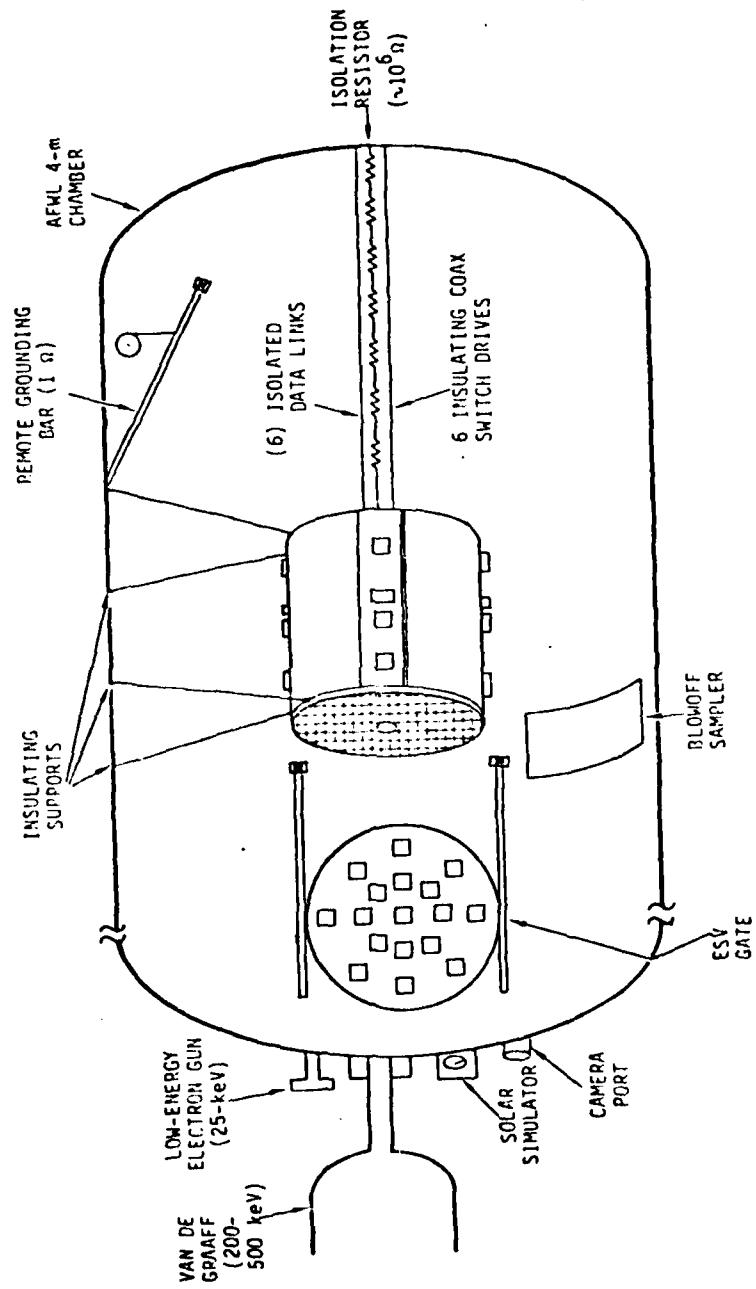
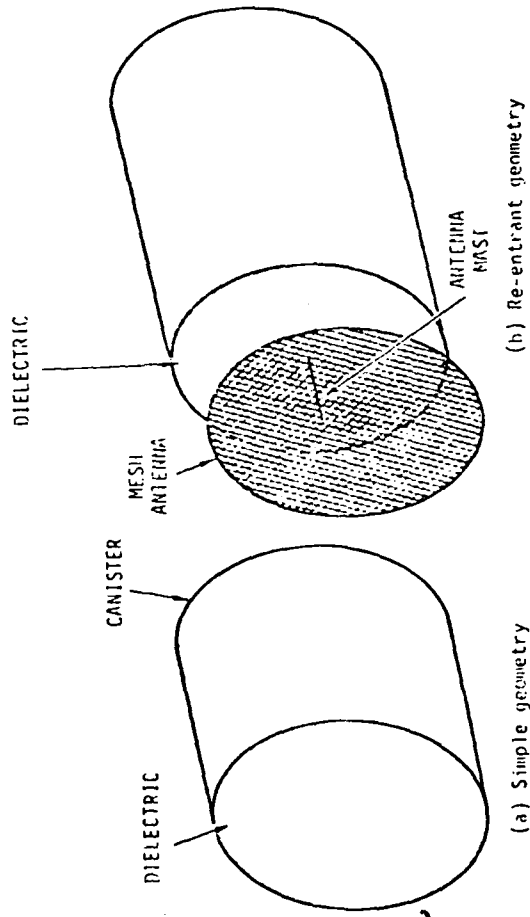

Figure 2. Phase III experimental configuration

RE-03017



HF-01239

Figure 3. Test Objects

of which frames are exempted in Figure 4 (from Ref 19). Excellent agreement between computed body response (rate of change of current) and the measurements on the cannister are shown in Figure 5. Figure 5 (from Ref 24) compares the measured and predicted response. The agreement is highly encouraging, inasmuch as this is far from a trivial calculation. It is seen that the difference between experiment and theory is no greater than the experimental variances.

The theory had difficulty with the simulated antenna mast of Figure 3b. For this geometry, the predicted mast current was 32 amps, and the measured response was 600 amps [24]. The suggested reasons for the discrepancy are plasma effects, energetic electron emission (could overcome space charge barrier), and a concentrated emission source.

From the calculations, one can conclude that the SGEMP-type codes can compute the coupled currents reasonably accurately for simple geometries. Re-entrant geometries can apparently have significant (order of magnitude) effects on currents.

## 2.5 MATERIAL DAMAGE MODELS

There is no significant change in the status of material damage models.

## 2.6 BURIED COMPONENTS MODEL

As part of the AFWL ECEMP program, Mallen, et al exposed FSC cables to high energy electrons and measured the discharge response [25]. It was found that shield currents ranged from 4 to 10 amps, with center wire currents on the order of 40 to 100 mA. Sufficient energy was coupled to upset

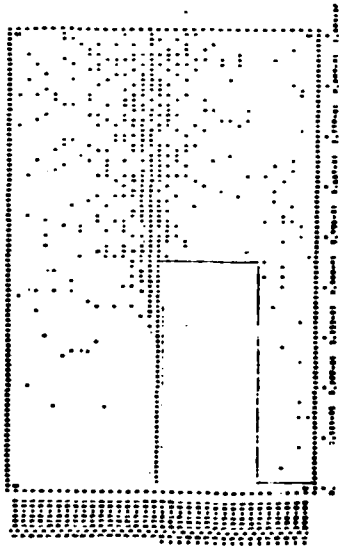

(a)  $t = 200$  nsec

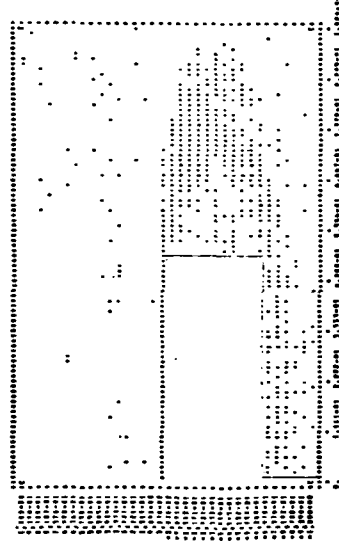

(b)  $t = 395$  nsec

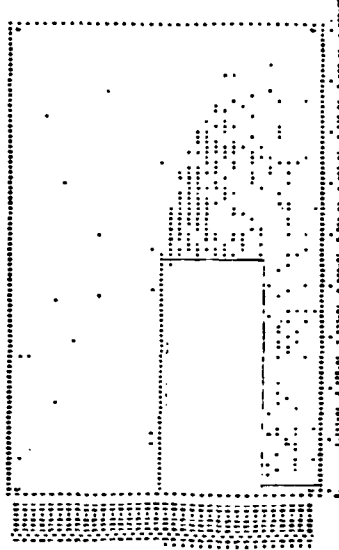

(c)  $t = 2$   $\mu$ sec

RE-02958

QUALITY PHOTOGRAPHY  
 1000 10th St. N.W.  
 WASHINGTON, D.C. 20004

Figure 4. Movie Plots of the Electron Cloud for Kapton Dielectric with High-Impedance Grounding and Uniform Emission (12.6 kV Initial Charge, 33% Blowoff)

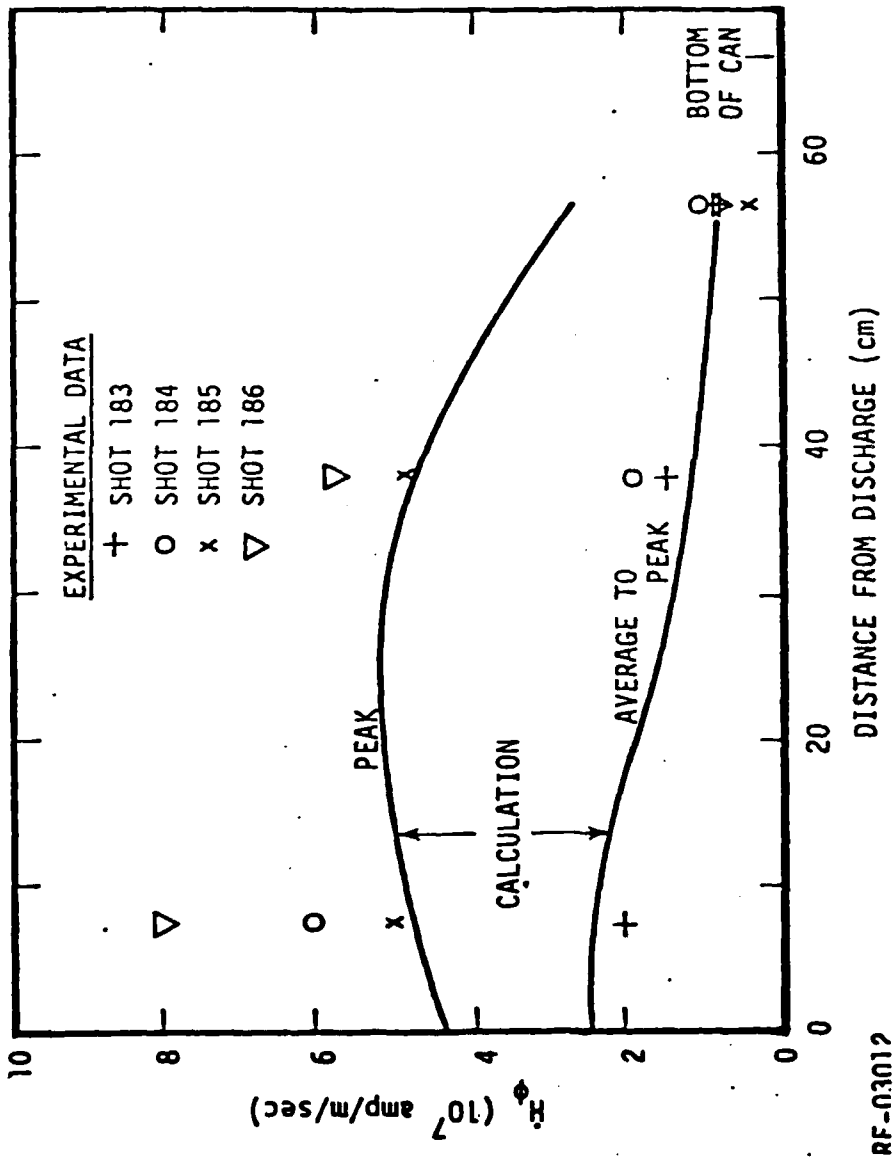

Figure 5. Comparison of Analytical and Experimental Results

standard logic. For the GPS cables, the shield and wire currents were lower, as were the cujac and aljac wire currents.

### 3.0 SYSTEM TEST AND EVALUATION

One of the primary objectives of the Spacecraft Charging Technology Program is to develop system level test procedures to augment the spark test suggested by MIL-STD-1541B. This is presently conceived to be a capacitive drive technique, wherein a pulser is capacitively coupled to the spacecraft and discharged, exciting the system resonances. It is felt that this type of simulation best simulates the blowoff charge released during the discharge.

One of the problems expected with this technique is the difficulty in simulating the low frequency components of the long duration discharge pulse.

IRT has previously performed Capacitively Drive Injection (CDI) Tests on the SCATSAT model of the P78-2 spacecraft [26]. This test technique will be validated by a test program in progress at IRT, in which the SCATSAT model will be irradiated in the NASA Lewis Research Center plasma substorm simulator. By inducing discharges on the SCATSAT, measuring the coupling to internal wires, it will be possible to obtain data for a direct comparison with the CDI results. The SCATSAT discharge data will also be used for comparison with the P78-2 data (TPM, SC1-8B), which will serve as a measure of the quality of ground test simulations. Of equal importance, the SABER predictions of SCATSAT response will be evaluated on the basis of comparison with the SCATSAT test data. Figure 6 shows the interlinking elements of the SCATHA test and analysis verification programs.

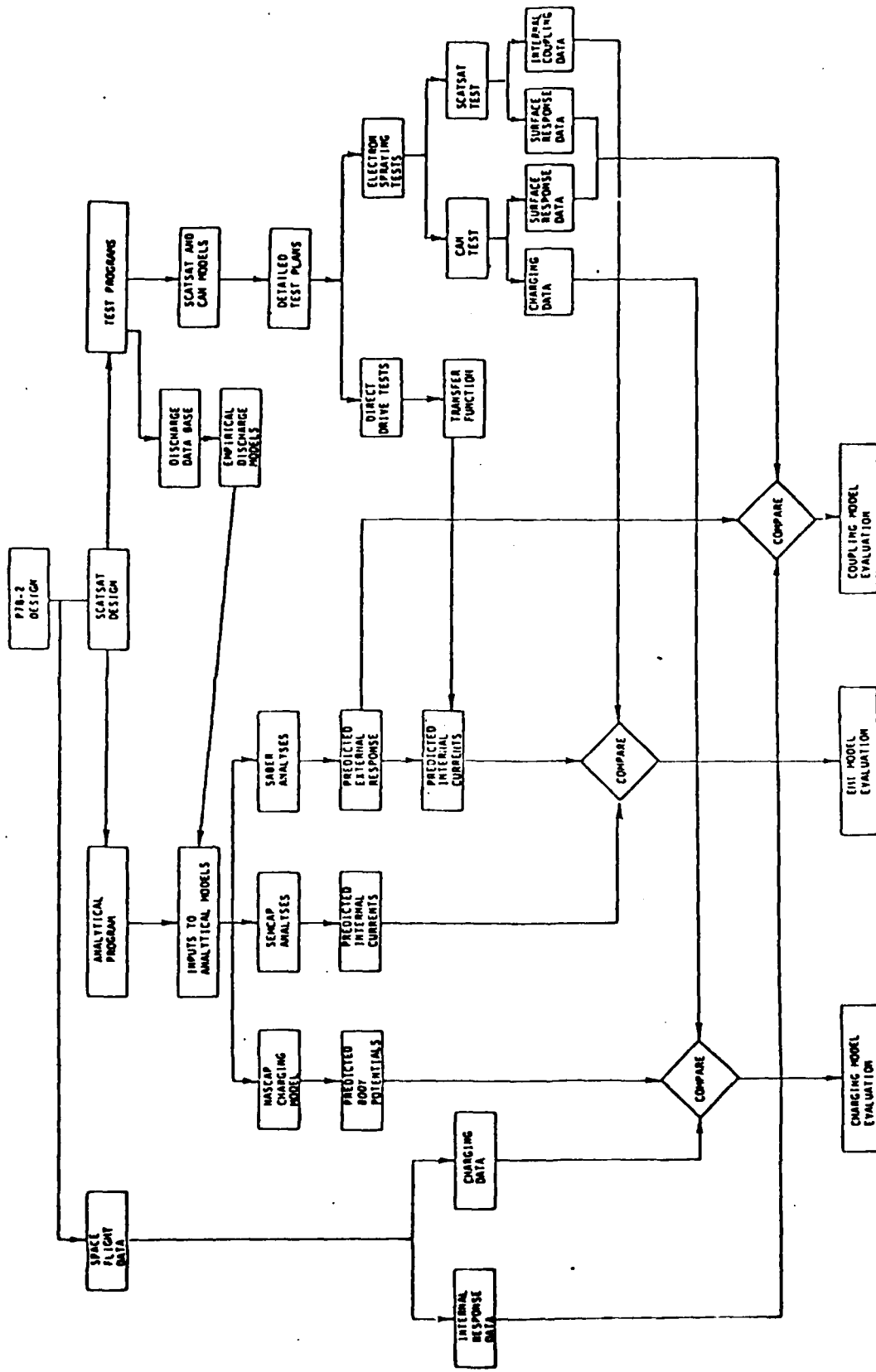

Figure 6. SCATHA Model Evaluation and Validation Program Flow Chart

The SCATSAT Test Program consists of two phases. In the first phase, conducted in April 1980, IRT irradiated a cylindrical test object referred to as the CAN. The purposes of the CAN test were to check out the instrumentation system and to obtain coupling data on a simple object which could be more easily understood analytically than could SCATSAT. Although severely limited in test time, the CAN test was generally successful [27]. A detailed description of the CAN test is contained in References 28 and 29, and the overall IRT program plan is described in Reference 30.

The SCATSAT electron spraying tests are currently scheduled for September 1980 and November 1980 (two separate test periods).

A system test and evaluation program for an operational spacecraft is described in Reference 31. METEOSAT, a meteorological satellite, has experienced a number of anomalies which are attributed to spacecraft charging. Electron irradiation tests were conducted on the thermal control surfaces and the radiometer mirror to identify arc sources. Simulated arcing tests and electron spraying tests of the spacecraft were also performed, and design changes based upon those results were recommended.

Another major system level test is planned as part of the AFWL ECEMP program. The FLTSATCOM Qual Model will be subjected to electron irradiations in conjunction with an SGEMP experiment [32]. This test is presently planned for July 1981.

#### 4.0 MIL STANDARD DEVELOPMENT

Under the present program plan for the Spacecraft Charging Technology Program, MIL-STD-1541 will be revised

by the end of FY82. From the point of view of the Model Validation Task, this requires validated models of environment, charging, discharge, and coupling, as well as a set of approved system test procedures by Oct 1981. It appears that the environmental and charging models will be adequate for this purpose.

In spite of a large amount of activity in the modeling of discharges, it does not appear that any organization has the responsibility of collecting all the data and formulating it into a model suitable for MIL STD purposes. SAI and Beers Associates have jointly proposed to provide this service for Space Division.

The coupling model also appears to have some risk. Of particular concern is the inability of ABORC to predict the large current observed on the antenna mast in the Jaycor experiment. At this phase of the program, no alternative to the SGEMP code approach appears feasible, however, and it is hoped that the SAI/BA discharge effort will be able to resolve the issue. Understanding that experiment will be a major task in the discharge modeling effort. (The feeling is that the coupling code performed properly, but the source term, i.e., the discharge, was not properly specified.)

The primary risk in the CDI test approach is the inability to inject pulse lengths of the proper duration. This is not expected to be a major problem, since the lower frequencies will probably not couple well to spacecraft. At worst, it may be necessary to overtest at the high frequencies to cover the specified spectral content at low frequencies.

## 5.0 P78-2 DATA ANALYSIS

On day 87, 1979, the SC1-8B (pulse analyzer) recorded an event on the harness wire sensor. This event coincided with a TPM event and a sudden drop in the spacecraft potential as determined by the SC9 spectrograph. Using the discharge data provided by Balmain [33] and the capacitive drive injection test data provided by IRT [26], O'Donnell and Bates [34] predicted the response of the SC1-8B sensor for that event. Figure 7 compares the predicted response (the solid line) and the SC1-8B measurement (vertical bars). Considering the crudeness of the data, the agreement is highly satisfactory.

Figure 8 shows the SC1-8B recording of a discharge event as detected by the external dipole. The solid line is a computer fit to the data [35]. These data were recorded with the pulse analyzer in Time State 6, which provides a better resolution of the pulse than was the case in Figure 7.

Although the external dipole detects the electric field strength external to the spacecraft, the waveform in Figure 8 should not be regarded as a measure of the discharge field. The reason is that the waveform in Figure 8 appears to be dominated by the satellite response. When IRT completes their measurements on the SCATSAT external dipole, it will be possible to interpret the data in Figure 8 more quantitatively.

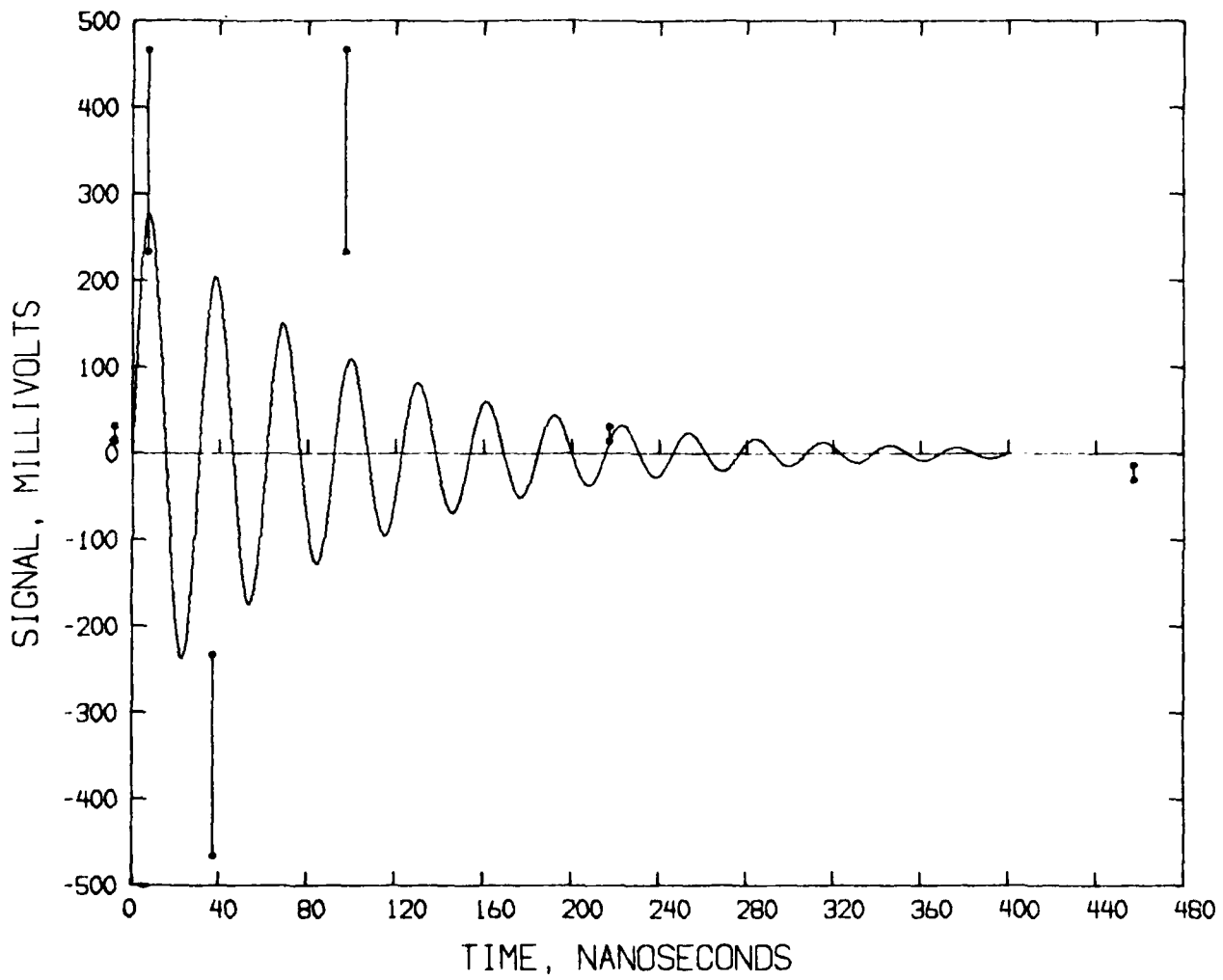

Figure 7. Predicted and Measured SCl-8B Response for the Event on Day 87, 1979

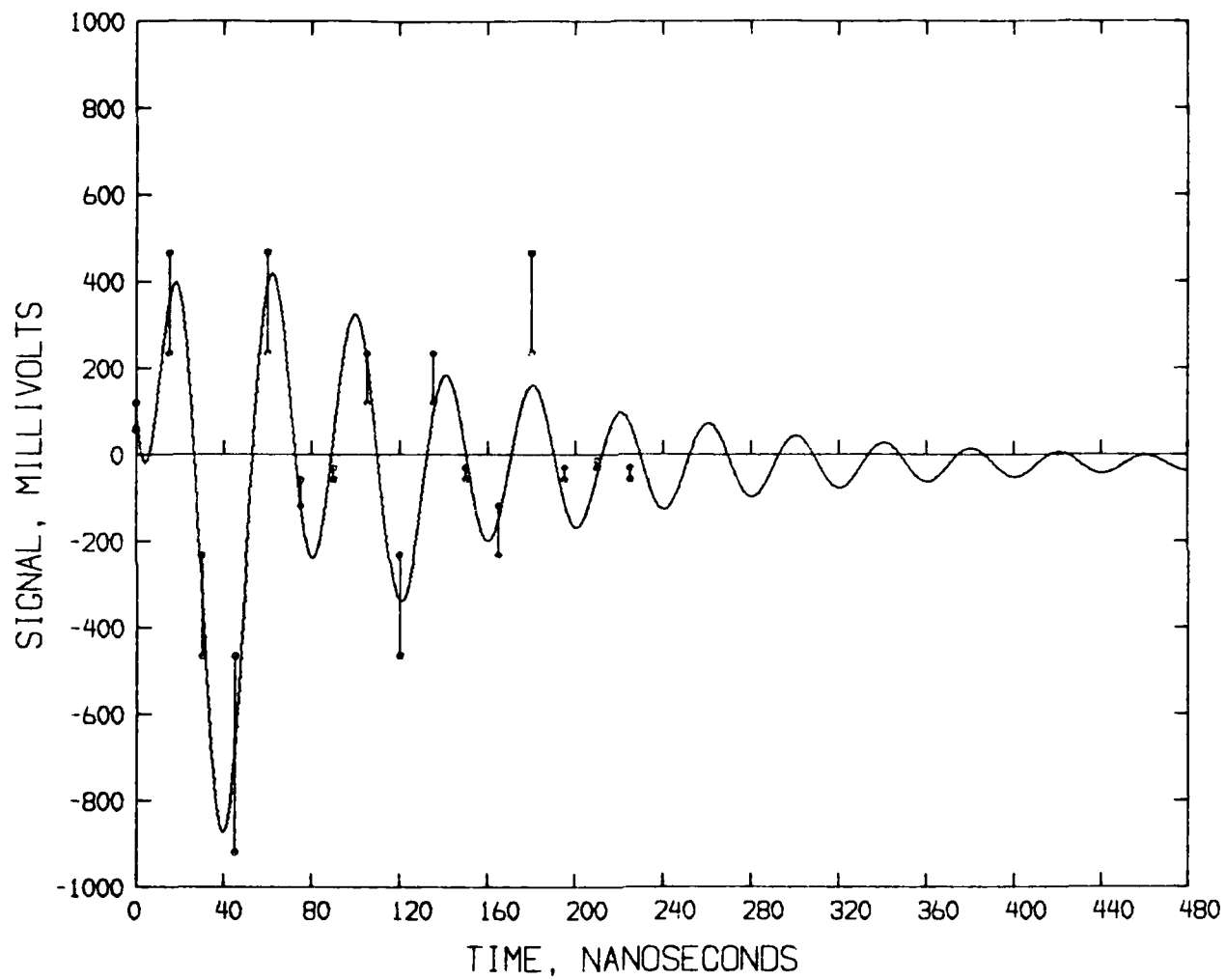

Figure 8. SC1-8B Measurement of External Dipole Response

## REFERENCES

1. "P78-2 SCATHA Preliminary Data Atlas," AFGL, 30 June 1980.
2. Stevens, N. John, et al, "Initial Comparison of SSPM Ground Test Results and Flight Data to NASCAP Simulations," presented at the 18th Aerospace Sciences Meeting, Pasadena, CA, 14 - 16 January 1980.
3. Treadaway, M. J., et al, "ECEMP Phase III Low Flux Tests," ECEMP Phenomenology Memo No. 46, Computer Sciences Corporation, 31 July 1980.
4. Schnuelle, G. W., et al, "Analysis of the Charging of the SCATHA (P78-2) Satellite," Systems, Science, and Software Report SSS-R-80-4339, March 1980.
5. Stevens, N. J., "Modeling of Environmentally Induced Discharges in Geosynchronous Satellites," presented at the 1980 IEEE Conference on Nuclear and Space Radiation Effects, Cornell U., July 1980.
6. Purvis, C., "Configuration Effects on Satellite Charging Response," presented at the 18th Aerospace Sciences Meeting, Pasadena, CA, January 1980.
7. Mandell, M. J., et al, "The Effect of Solar Array Voltage Pattern on Plasma Power Losses," presented at the 1980 IEEE Conference on Nuclear and Space Radiation Effects, Cornell U., July 1980.
8. Stevens, N. J., "Space Environmental Interactions with Buried Spacecraft Surfaces, " NASA Technical Memorandum 79156, May 1980.

9. Stettner, R., and R. N. Marks, "Phenomenological Discharge Models and Associated Scaling Laws," ECEMP Phenomenology Memo No. 44, Computer Sciences Corporation, 30 June 1980.
10. Katz, I, et al, "A Theory of Dielectric Surface Discharges," presented at the 1980 IEEE Conference on Nuclear and Space Radiation Effects, Cornell U., July 1980.
11. Stettner, R., and Dancz, "A Field Enhanced Cleanoff Model of Dielectric Discharges," ECEMP Phenomenology Model No. 23, Computer Sciences Corporation, April 1979.
12. TRW Corporation Monthly Progress Report for April 1980, TRW Report No. 36186-6007-UE-00, "Implications of Arcing due to Spacecraft Charging on Spacecraft Margins of Immunity."
13. Beers, B. L., et al, "Theoretical Support for Arc Discharge Experiments," Beers Associates Final Report No. 1-80-14-10, March 1980.
14. Milligan, B., et al, "Spacecraft Discharge Characterization - Test Setup, Quick-Look Experiments, and Preliminary Model Development," SRI Draft Final Report, December 1979.
15. Balmain, K. G., and W. Hirt, "Dielectric Surface Discharges: Dependence on Incident Electron Flux," presented at the 1980 IEEE Conference on Nuclear and Space Radiation Effects, Cornell U., July 1980.
16. Yadowski, et al, "Characteristics of Edge Breakdowns on Teflon Samples," Inland Research & Development Center, presented at the 1980 IEEE Conference on Nuclear and Space Radiation Effects, Cornell U., July 1980.

17. Mallon, C. E., et al, "Spontaneous Discharges in an FSC Solar Panel Exposed to High and Low Energy Electrons," ECEMP Phenomenology Memorandum No. 32, Computer Sciences Corporation, 1 August 1980.
18. Jim Knighton, IRT Corporation, private communication.
19. "Minutes: ECEMP Phase III Pretest Analysis Review Meeting," ECEMP Phenomenology Memorandum No. 38, Computer Sciences Corporation, 29 January 1980.
20. Treadaway, M. J., et al, "ECEMP Phase 3 Detailed Test Plan," ECEMP Phenomenology Memorandum No. 36, Computer Sciences Corporation, 1 October 1979.
21. "Minutes: ECEMP Phase III Progress Review Meeting," ECEMP Phenomenology Memorandum No. 40, Computer Sciences Corporation, 13 March 1980.
22. Treadaway, M. J., et al, "Experimental Verification of an ECEMP Spacecraft Discharge Coupling Model," ECEMP Phenomenology Memorandum No. 45, Computer Sciences Corporation, 25 July 1980.
23. ECEMP Phase III Instrumentation, "ECEMP Phenomenology Memorandum No. 50, Computer Sciences Corporation, 12 August 1980.
24. "Minutes - ECEMP Phase III Post-Test Review Meeting," ECEMP Phenomenology Memorandum No. 43, Computer Sciences Corporation, 10 June 1980.
25. Mallon, C. E., et al, "High Energy Electron-Induced Discharges and SGEMP Modification in Cables," ECEMP Phenomenology Memorandum No. 29, Computer Sciences Corporation, 1 August 1979.

26. "Electron-Induced Discharge Modeling, Testing, and Analysis for SCATHA, Vol II - Comparison of Internal Coupling Produced by Two EID Simulation Techniques," IRT Corporation, December 31, 1978.
27. Wilkenfield, J., "SCATHA Model Tests," IRT-8195-010, IRT Corporation Monthly Progress Narrative for May 1980.
28. Wilkenfield, J., et al, "Spacecraft Charging Tests on the CAN with a Multi-Component Environmental Simulation," Draft Test Plan, IRT 8195-004, 5 February 1980.
29. Wilkenfield, J., "Spacecraft Charging Tests on the CAN," Supplement to the Original Test Plan, IRT 8195-004-1, 28 March 1980.
30. Wilkenfield, J., "SCATHA Model Tests Original Work Plan," IRT 8195-001, 12 October 1979.
31. Robbins, A., "METEOSAT Spacecraft Charging Investigation," Royal Aircraft Establishment Tech Report 79132, October 1979.
32. Schiff, A. T., and D. Higgins, "FLTSATCOM SGEMP/ECEMP Phase II Final Test Requirements Document," FLTSATCOM Experimentation Memo #93, Computer Sciences Corporation, 8 August 1980.
33. Balmain, K. G., and G. R. Dubois, "Surface Discharges on Teflon, Mylar, and Kapton," presented at the 1979 IEEE Conference on Nuclear and Space Radiation Effects, Santa Cruz, CA, July 1979.
34. O'Donnell, E., and L. Bates, "Interpretation of P78-2 Data using Ground Test Data," SAI-80-201-CS, 7 January 1980.

35. Memo from Harry Koons to Lt. R. Osgood, "Pulse Detected by SC1-8B on 16 April 1980," Aerospace Corporation, 21 April 1980.