

AD-A091 642

ROME AIR DEVELOPMENT CENTER GRIFFISS AFB NY  
THE FEDERAL AVIATION ADMINISTRATION LIGHTNING PROTECTION MODULE--ETC(U)  
MAY 80 R M COSEL, M FIGUEROA

F/G 9/1

DOT-FA72WAI-356

UNCLASSIFIED

FAA-RD-80-119

NL

1 of 1  
AD A  
091642

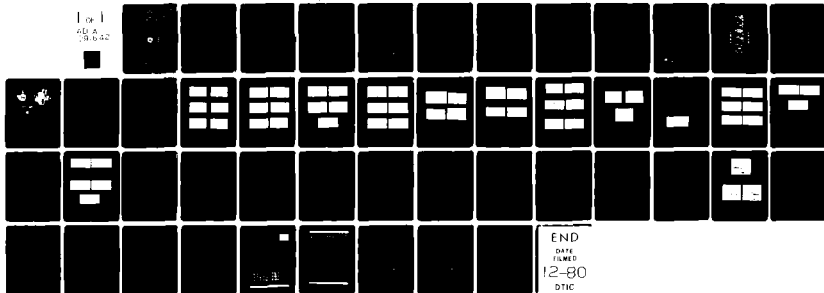

END  
DATE  
FILMED  
12-80  
DTIC

Report No. FAA-RD-80-119

**LEVEL II**

12

**FEDERAL AVIATION ADMINISTRATION LIGHTNING  
PROTECTION MODULES DESIGNED FOR  
LEADLESS DEVICES**

AD A091642

Richard M. Cosel  
Manuel Figueroa  
Department of Defense  
Rome Air Development Center  
Rome, N.Y. 13441



DTIC  
ELECTE  
NOV 12 1980  
S D E

May 1980

Document is available to the U.S. public through  
the National Technical Information Service,  
Springfield, Virginia 22161.

Prepared for

**U.S. DEPARTMENT OF TRANSPORTATION  
FEDERAL AVIATION ADMINISTRATION  
Systems Research & Development Service  
Washington, D.C. 20590**

DUPLICATE

80 10 30 058

111

NOTICE

This document is disseminated under the sponsorship of the Department of Transportation in the interest of information exchange. The United States Government assumes no liability for its contents or use thereof.

The United States Government does not endorse products or manufacturers. Trade or manufacturers names appear herein solely because they are considered essential to the object of this report.

19

1. Report No. 18 FAA-RD 80-119	2. Government Accession No. AD-A091642	3. Recipient's Catalog No.	
4. Title and Subtitle Federal Aviation Administration The Lightning Protection Modules Designed for Leadless Devices		5. Report Date 11 May 80	6. Performing Organization Code
7. Author(s) 10 Richard M. Cosel and Manuel Figueroa		8. Performing Organization Report No. 12 47	
9. Performing Organization Name and Address Department of Defense U.S. Air Force Rome Air Development Center Rome, New York 13441		10. Work Unit No. (TRAIS) 16 9567 0006 12 8	11. Contract or Grant No. 15 DOT-FA72WAI-356
12. Sponsoring Agency Name and Address Department of Transportation Federal Aviation Administration Systems Research & Development Service Washington, D. C. 20590		13. Type of Report and Period Covered	
14. Sponsoring Agency Code ARD-350		15. Supplementary Notes Prepared by Post Doctoral Program, Rome Air Development Center	
16. Abstract The silicon avalanche diode transient suppressor is widely used to protect low level solid state devices against voltage transients. There has been a problem, however, in providing suitable low loss, low inductive installation mountings especially in retrofit cases. This report describes two mounting systems developed for the FAA, a barrier strip designated FA9455, for direct current, pulsed or audio lines and coaxial holder designated FA9479 for 50 or 72 ohm video or F.R. lines. Tests were performed using both conventionally constructed suppressors and low capacity units at voltage ratings varying from 6.8 volts to over 50 volts and including bipolar and unipolar devices. Square wave tests on the barrier strip, insertion loss tests on the coaxial module and surge testing of both modules indicated that within test parameters, the devices are limited only by the capabilities of the surge suppressor used. i.e. They are device limited.			
17. Key Words Lightning Protection Transient Supression Lightning Protection Module LPM		18. Distribution Statement Document is available to the public Through the National Technical Information Service, Springfield, VA. 22151.	
19. Security Classif. (of this report) Unclassified	20. Security Classif. (of this page) Unclassified	21. No. of Pages 47	22. Price

309050

# METRIC CONVERSION FACTORS

Approximate Conversions to Metric Measures				Approximate Conversions from Metric Measures			
Symbol	When You Know	Multiply by	To Find	Symbol	When You Know	Multiply by	To Find
<b>LENGTH</b>							
in	inches	2.5	centimeters	mm	millimeters	0.04	inches
ft	feet	30	centimeters	cm	centimeters	0.4	inches
yd	yards	0.9	meters	m	meters	3.3	feet
mi	miles	1.6	kilometers	km	kilometers	1.1	yards
						0.6	miles
<b>AREA</b>							
sq ft	square inches	6.5	square centimeters	sq cm	square centimeters	0.16	square inches
sq ft	square feet	0.09	square meters	sq m	square meters	1.2	square feet
sq yd	square yards	0.8	square meters	sq m	square meters	0.4	square yards
sq mi	square miles	2.6	square kilometers	sq km	square kilometers	2.5	square miles
	acres	0.4	hectares	ha	hectares (10,000 m <sup>2</sup> )		acres
<b>MASS (weight)</b>							
oz	ounces	29	grams	g	grams	0.035	ounces
lb	pounds	0.45	kilograms	kg	kilograms	2.2	pounds
	short tons (2000 lb)	0.9	tonnes	t	tonnes (1000 kg)	1.1	short tons
<b>VOLUME</b>							
cup	teaspoons	5	milliliters	ml	milliliters	0.03	fluid ounces
fl oz	tablespoons	15	milliliters	ml	milliliters	2.1	fluid ounces
qt	fluid ounces	30	milliliters	ml	milliliters	1.05	pints
pt	cup	0.24	liters	l	liters	0.26	quarts
qt	pints	0.47	liters	l	liters	0.76	gallons
gal	quarts	0.95	liters	l	liters	3.8	gallons
cu ft	gallons	3.8	cubic meters	m <sup>3</sup>	cubic meters	1.3	cubic feet
cu yd	cubic feet	0.03	cubic meters	m <sup>3</sup>	cubic meters		cubic yards
	cubic yards	0.76					
<b>TEMPERATURE (exact)</b>							
°F	Fahrenheit temperature	5/9 (after subtracting 32)	Celsius temperature	°C	Celsius temperature	9/5 (then add 32)	Fahrenheit temperature

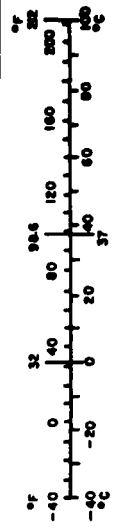
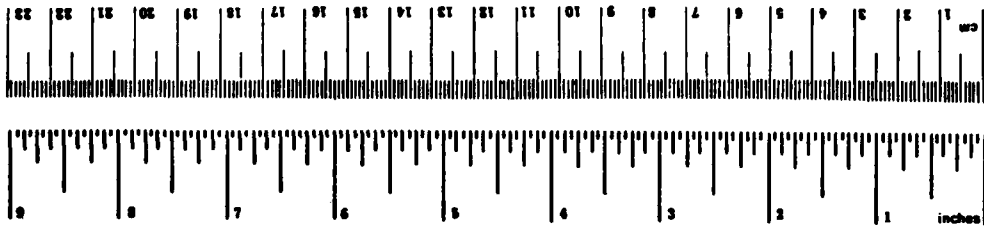

\* 1 in = 2.54 (exact). For other exact conversions and more detailed tables, see NBS Misc. Publ. 26, Units of Weight and Measure, Price \$2.25, SD Catalog No. C 1310286.

## TABLE OF CONTENTS

	Page
Table of Contents	i
List of Illustrations and Tables	ii
Forward	iv
Chapter 1 Introduction	1
Chapter 2 Test Program	6
2.1.2 Surge Tests	16
2.2.1 Lightning Protection Module, Coaxial, FA9479	21
2.2.2 Surge Tests	30
Chapter 3 Conclusions and Recommendations	32
Appendix A Relationship derivation, transmission loss/return loss	33
Appendix B References	35
Appendix C Specification Sheets, leadless TransZorb <sup>®*</sup>	36

Accession For	
NTIS GRA&I	<input checked="" type="checkbox"/>
DDC TAB	<input type="checkbox"/>
Unannounced	<input type="checkbox"/>
Justification	
By _____	
Distribution/	
Availability Codes	
Dist.	Avail and/or special
A	

\*TM, General Semiconductor Industries

## LIST OF ILLUSTRATIONS AND TABLES

	Page
Figure 1 General Semiconductor Leadless TransZorb	2
Figure 2A Lightning Protection Module (LPM) FA9455A Showing Diode Insertion and Parts Mounting	3
Figure 2B Lightning Protection Module (LPM) FA9455A Plan View	4
Figure 3 Lightning Protection Module, Coaxial (LPMC) FA9479	5
Figure 4 Square Wave Test, 1.5KC7.5 in LPM 9455A	8
Figure 5 Square Wave Test, 1.5KC36 in LPM 9455A	9
Figure 6 Square Wave Test, 1.5KC51 in LPM 9455A	10
Figure 7 Square Wave Test, GZ92111A in LPM 9455A	11
Figure 8 Square Wave Test, GZ92111B in LPM 9455A	12
Figure 9 Square Wave Test, GZ60316B in LPM 9455A	13
Figure 10 Square Wave Test, Comparisons, Units in LPM 9455A	14
Figure 11 Zener Curves, GZ60316B and GZ92111A	11
Figure 12 Surge Generator, Simplified Schematic	16
Figure 13 Surge Generator, Typical response Curve	16
Figure 14 Surge Tests, Stock TransZorb's in FA9455A	17
Figure 15 Surge Tests, Low Capacity Unipolar Units in FA9455A	18
Figure 16 Surge Tests, Avalanche Diodes With Leads	20
Figure 17 Surge Tests, Gas Tube Devices in FA9455A	20
Table 1 Printout, Insertion Loss-Return Loss LPMC FA9479 Empty	23
Table 2 Printout, Insertion Loss-Return Loss 2-GZ92111A in LPMC FA9479	24
Figure 18 Curve, Insertion Loss vs Frequency, LPMC FA9479 Empty	25
Figure 19 Curves, Insertion Loss and VSWR vs Frequency 2GZ92111A in LPMC FA9479	25

LIST OF ILLUSTRATIONS AND TABLES CONT'D

	Page
Table 3     Printout, Insertion Loss-Return Loss 2-GZ92111B in LPMC FA9479	26
Table 4     Printout, Insertion Loss-Return Loss 2-GZ60316B in LPMC FA9479	27
Figure 20   Curves, Insertion Loss and VSWR vs Frequency, 2GZ92111B in LPMC FA9479	28
Figure 21   Curves, Insertion Loss and VSWR vs Frequency, 2GZ60316B in LPMC FA9479	28
Table 5     Printout, Calibration Check of Hewlett Packard 8507B Automatic Network Analyzer	29
Table 6     Comparison Chart	22
Figure 22   Surge Tests - 2GZ60316B	31

## FORWARD

This report was prepared by the Department of Electrical Engineering, Florida Institute of Technology as a participant in the Post Doctoral Program at the Rome Air Development Center. The effort was conducted via RADC Job Order No. 9567 for the Federal Aviation Administration under Contract No. DOT-FA 72 WAI-356. The Contract was administered under the direction of Mr. Fred S. Sakate, ARD 350, FAA Washington, D.C. The tests were directed by Richard M. Cosel. The author wishes to acknowledge with thanks the assistance of Mr. J. T. Pizzicaroli of General Semiconductor Industries in performing certain surge tests, Mr. Larry Sadler of the Harris Corporation in providing insertion loss data, Mr. Keith Huddleston, Georgia Institute of Technology for loan of his surge generator and Mrs. Marjorie Quaiel for preparation of the final manuscript.

## CHAPTER I

### INTRODUCTION

The use of silicon avalanche diodes for suppression of induced transients has been widely documented. The standard low power units which appeared on the market were packaged much the same as ordinary rectifier diodes, i.e., axial or stud mounting. While these were reasonably simple to wire into existing circuitry, several inherent problems surfaced. The problems mainly involved the packaging (physical arrangement) to provide protection at line termination points such as the demarcation box at a facility entrance, and the inductance (which could be significant) added by device leads.

The FAA, recognizing these problems decided to attack on both fronts simultaneously. First of all in conjunction with General Semiconductor Industries, a family of leadless devices was developed. These devices - Figure I - are now catalog items (1) in breakdown voltages ranging from 6 to 115 volts in both unipolar and bipolar form. Also available are low capacity units (2) which have been tested for insertion loss at frequencies up to 1.0GHz.

The second task, a logical outgrowth of the first was to develop a family of suitable holders or modules which meet the following goals:

- Ease of installation
- Minimum lead length
- Use with single or multiple twisted pair lines
- Use with coaxial lines

Through the RADC Post Doctoral Program, Florida Institute of Technology was given the task of development of both a holder which would replace the typical barrier strip and a second unit for use in coaxial line. The resulting barrier strip shown in Figure 2, A and B is made in two lengths. The FA9455A is a five device unit while the B version holds 10 devices. Illustration 2A shows a module with components for a

typical protection circuit in stages of installation. While five or ten devices can be accommodated, this does not necessarily equate to five or ten lines. The size and shape of the diode inserts were specifically selected so that the unit would be interchangeable with available miniature gas tubes. Thus in a more complex suppression circuit, two or more positions can be used with one line. The crossover connector provided is shown at the top.

The coaxial module FA9479 Figure 3, was fabricated using a standard UG 28A/U type N Tee. As can be seen from the illustration, the throughput goes through the head of the Tee and the protection device is in the modified leg. The center line connector has been replaced with a flat head screw and insulating cup. The low capacity units available in the leadless configuration were unipolar devices. In order to accommodate two diodes for bipolar operation, the cap was redesigned, extended to provide added space. Originally a conical spring was used as the internal contact. However, because the spring had too much inductance the cap was redesigned to make use of a flat Belleville washer type spring. In production, the adjustable screw would be replaced with a fixed contact.

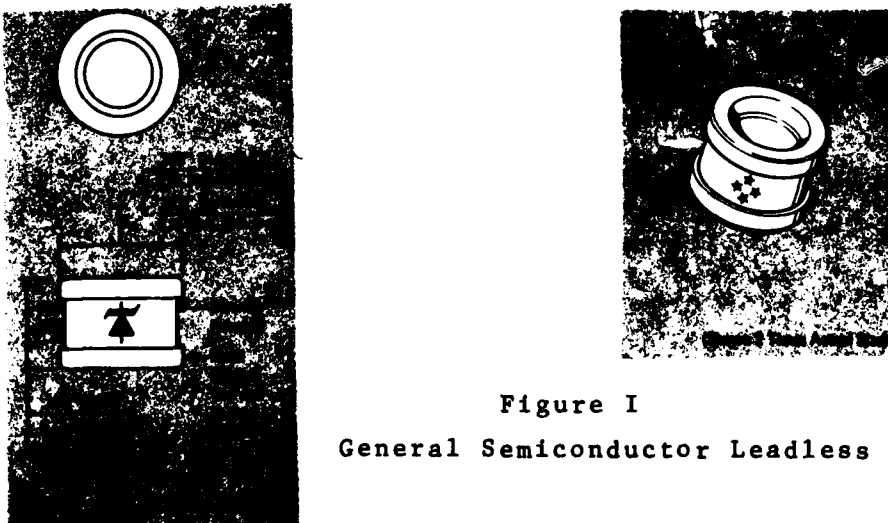

Figure I  
General Semiconductor Leadless TransZorb C

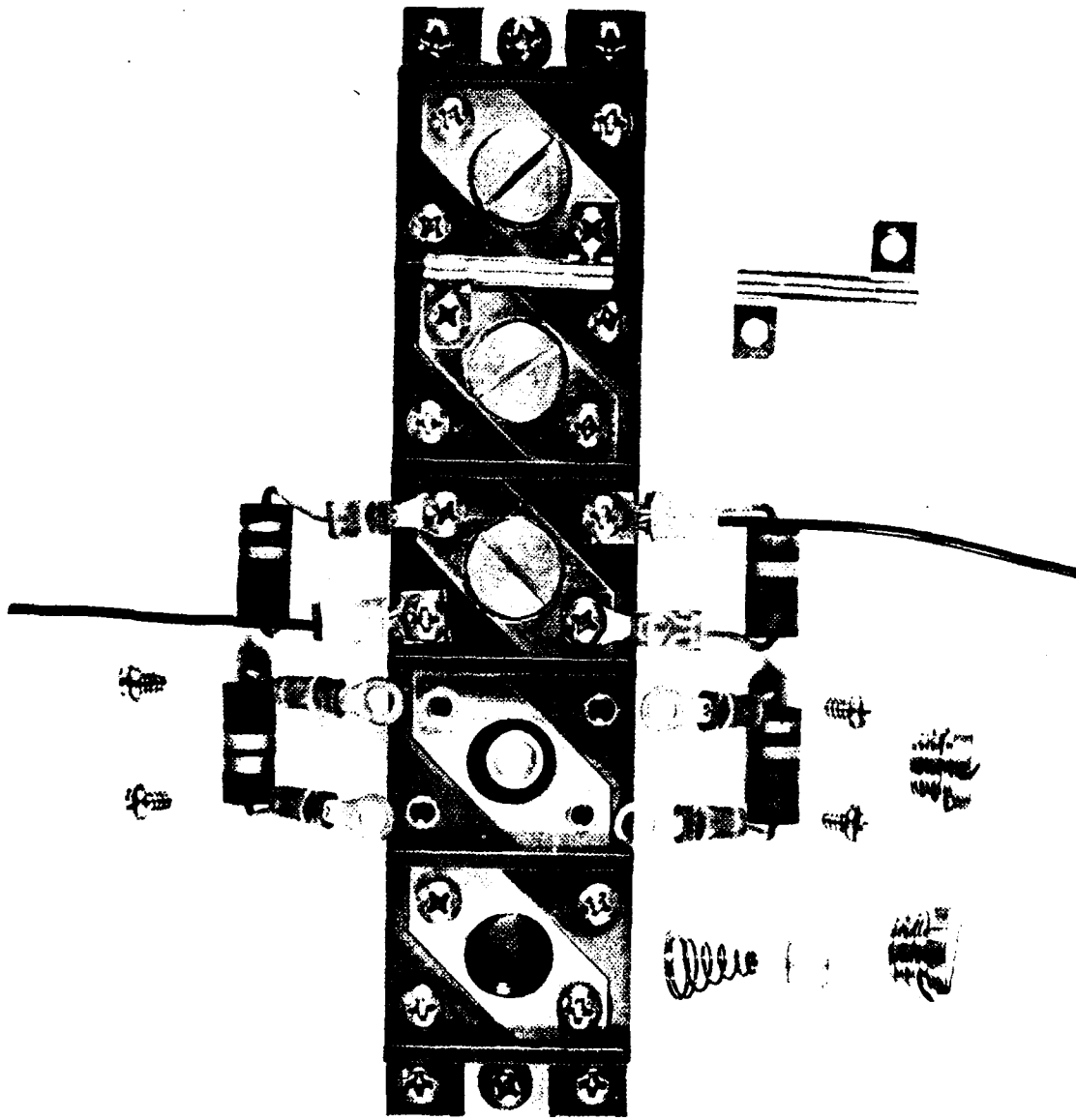
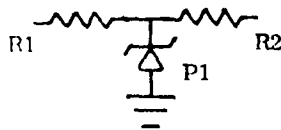

Figure 2A

Lightning Protection Module (LPM) FA9455A showing diode insertion and resistor mounting for the most common arrangement.

Resulting Circuit



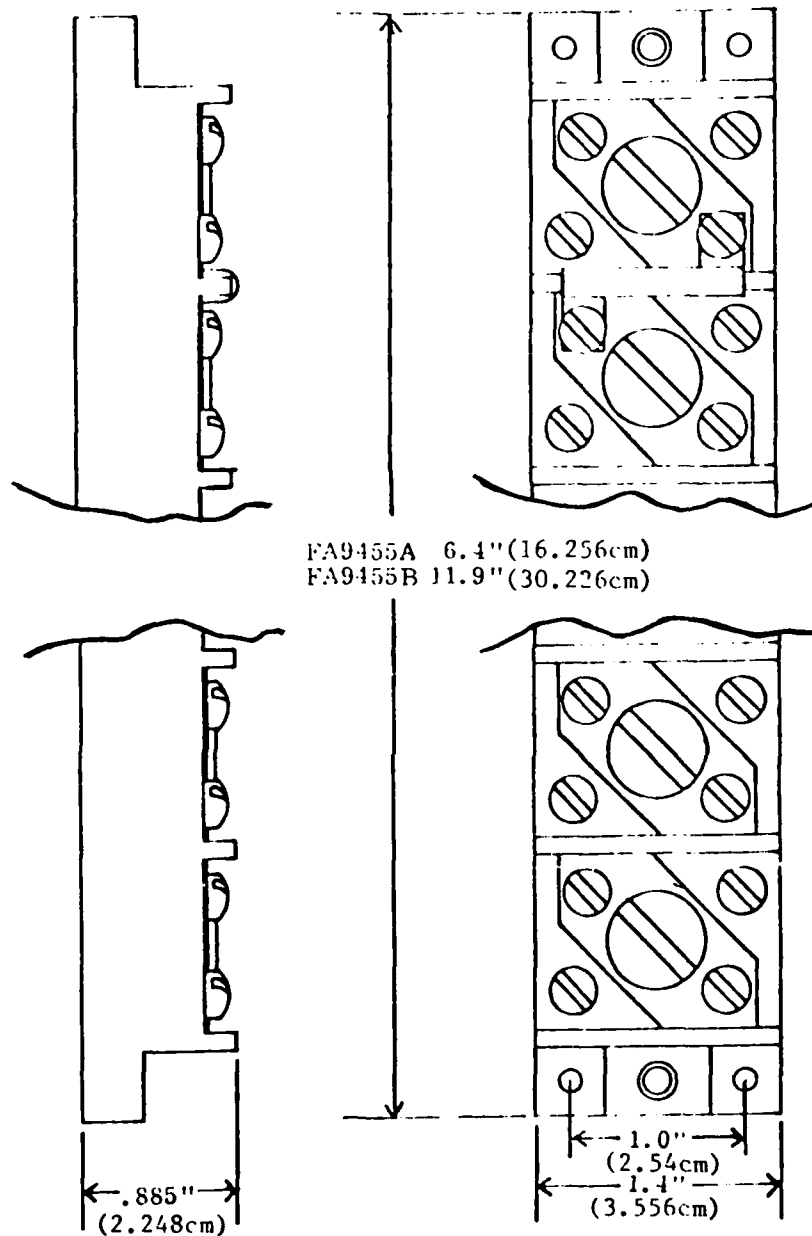

Figure 2B

Lightning Protection Module, Plan View

The 5 Terminal unit is designated FA9455A

The 10 Terminal unit is designated FA9455B

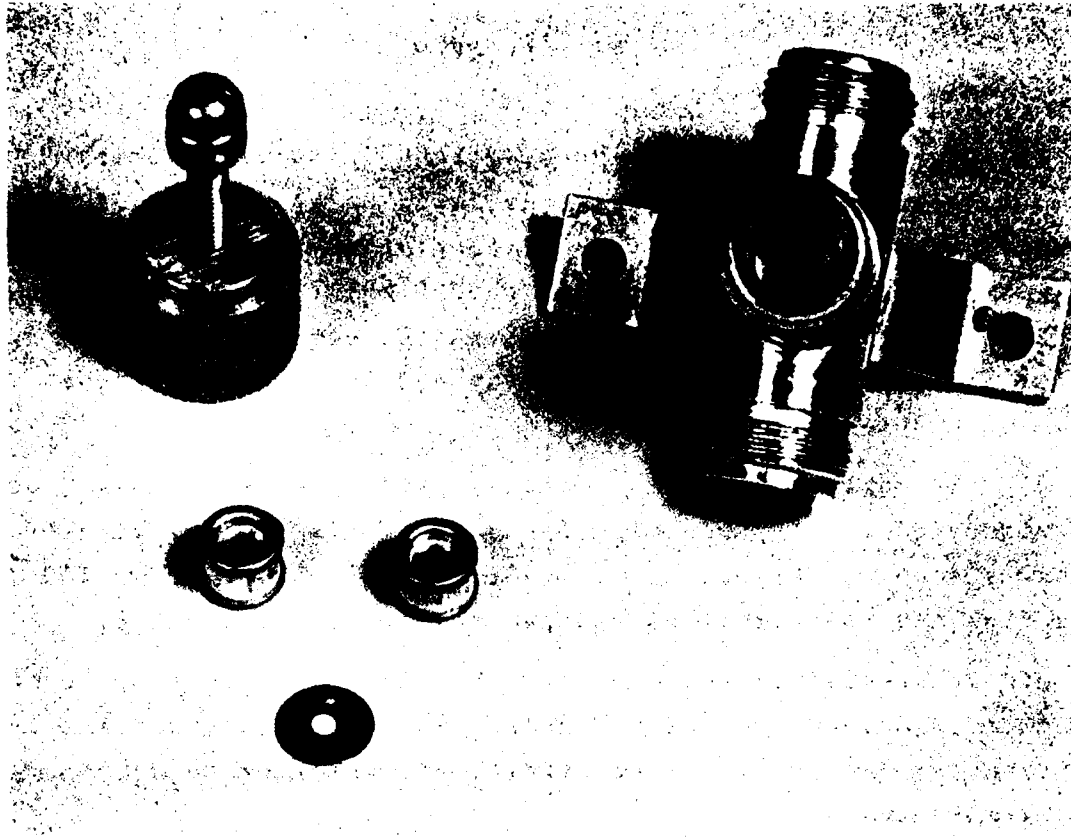

Figure 3

FA 9479

Lightning Protection Module, Coaxial (LPMC)

Note that a cupped "belleville" type washer has been substituted for the conical spring washer substantially reducing inductance effects. Space for two suppression devices has been extended using a redesigned cap. In production, the adjustable screw contact would be replaced by a fixed contact.

## CHAPTER 2

### TEST PROGRAM

#### 2.1 Lightning Protection Module, FA9455 (Barrier Strip)

Suppression Characteristics, such as peak power dissipation and breakdown voltage of the protective devices are listed in appropriate catalogs. (1) Of specific interest in applying the devices to existing circuits is the effect the device and its holder may have on the quality and level of the signal being transmitted.

The barrier strip is commonly used to connect single or twisted pair telephone type lines. Signals include pulsed d.c. and sinusoidal signals from low frequency power (60 or 400 Hertz) and control lines and the audio frequency range.

In special cases, clock synchronization pulses up to 10MHz are accommodated on twisted pair. However, the input and output circuitry is specially conditioned and designed to accommodate degraded pulse shapes.

##### 2.1.1 Square Wave Tests

A series of square wave tests were run using both standard and low capacity diodes. Degradation effect of the lines themselves was minimized by using short leads and no termination in order to picture solely the effect of the suppression device in combination with the module. The square wave pulse generator used was a Hewlett Packard 211A with a maximum frequency of 1 MHz and an output of 55 volts across a 600 $\Omega$  internal impedance. The rise time specification is less than .1 $\mu$  sec.

The barrier strip was tested using the following devices: 1.5KC7.5, 1.5KC36, 1.5KC51, GZ92111A, GZ92111B and the GZ60316B. All are unipolar devices. Tests with available bipolar units showed no significant differences. Test results are shown in figures 4 through 10. In each case the test voltage shown is just

below the clipping point unless otherwise indicated. It is interesting to note that in this "large signal" test case, with the exception of the 6.8 volt device, GZ60316B, the apparent square wave distortion is related more to the device voltage rating than to the diode "low signal" capacitance. Thus the 36 volt devices 1.5KC36 (standard capacity) and the GZ92111A (low capacity), show essentially similar wave shapes at corresponding frequencies. The GZ60316Bs, low capacity devices of earlier manufacture had all been subjected to extensive surge testing and exhibited rounded zener knees indicative of leakage. The insertion loss curve, Figure 21, also shows an apparent resonance effect which seems to be unique to the construction of this particular series. Figures 11A and B shows the comparison of the 'knees' of the GZ60316B and GZ92111A both to the same scale of 5 volts/division. Figure 11C shows the 'knee' of the GZ60316B somewhat expanded at 2 volts/division.

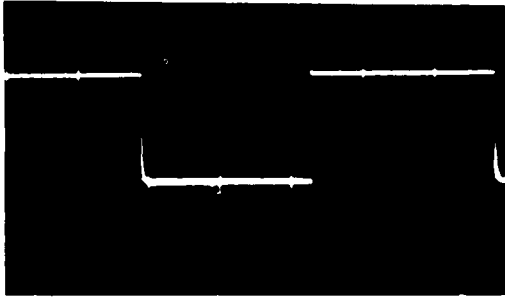

1. 1000 H<sub>Z</sub>  
5 v/cm, 100 μsec x 2

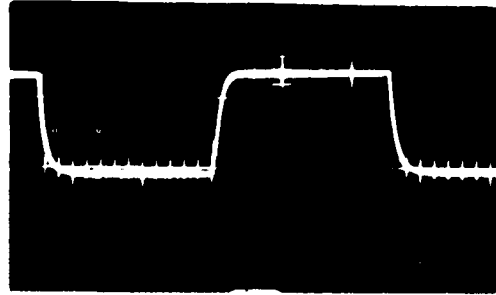

2. 10 KHz  
5 v/cm, 10 μsec x 2

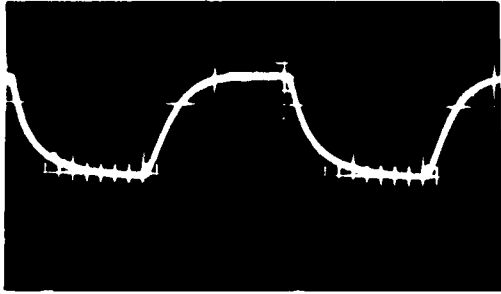

3. 50 KHz  
5 v/cm, 1 μsec x 5

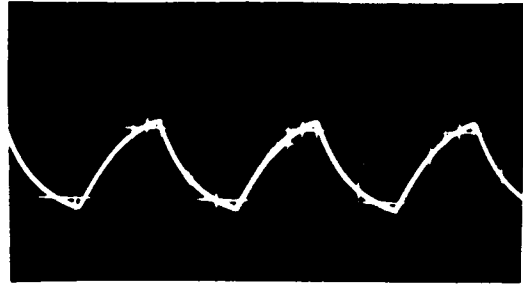

4. 100 KHz  
5 v/cm, 1 μsec x 5

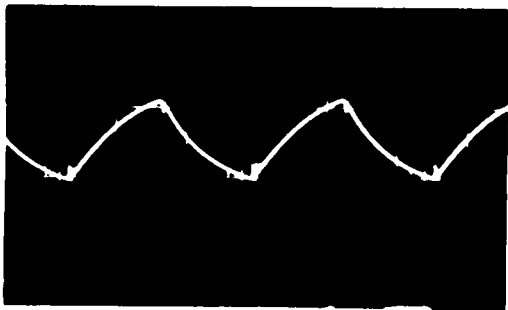

5. 200 KHz  
5 v/cm, 1 μsec x 2

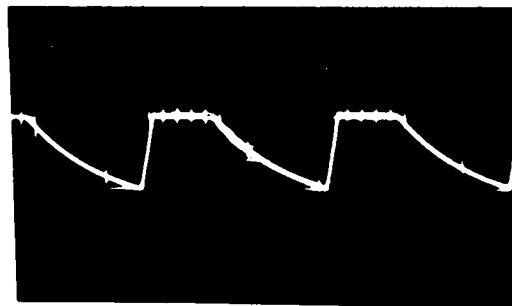

6. 200 KHz  
5 v/cm, 1 μsec x 2  
(Showing Clipping Action)

Figure 4  
Square Wave Test  
1.5KC7.5 (V<sub>B</sub> 7.76) Mounted in LPM 9455A



1. 1000 Hz  
10 v/cm, 100  $\mu$ sec x 2

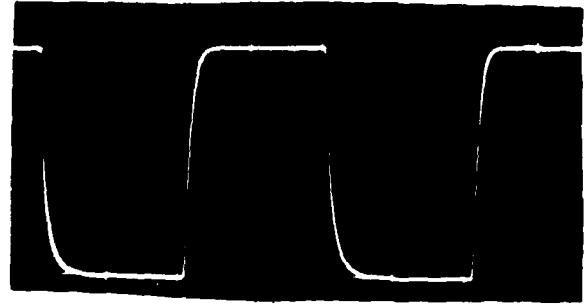

2. 50 KHz  
10 v/cm, 1  $\mu$ sec x 5

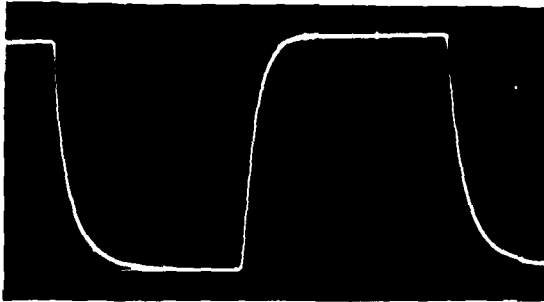

3. 100 KHz  
10 v/cm, 1  $\mu$ sec x 2

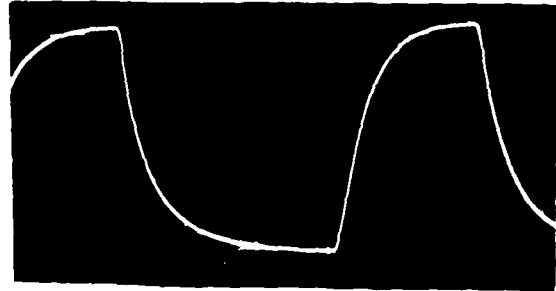

4. 200 KHz  
10 v/cm, 1  $\mu$ sec x 1

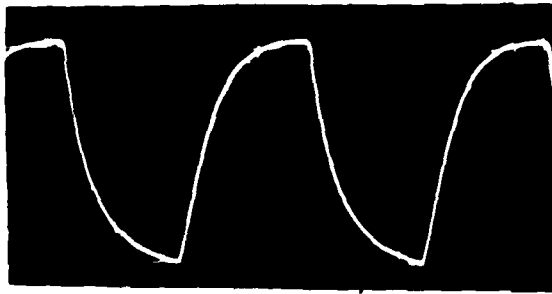

5. 300 KHz  
10 v/cm, 1  $\mu$ sec x 1

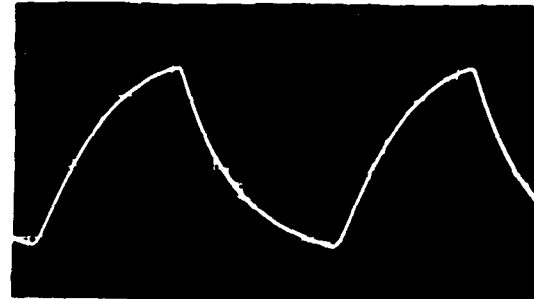

6. 500 KHz  
10 v/cm, .1  $\mu$ sec x 5

Figure 5  
Square Wave Test  
1.5KC36 ( $V_B$  33.36) Mounted in LPM 9455A

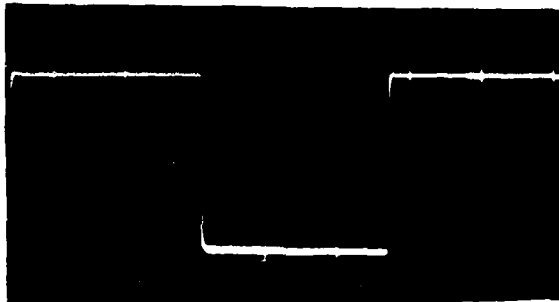

1. 10 KHz  
20 v/cm, 10  $\mu$ sec x 2

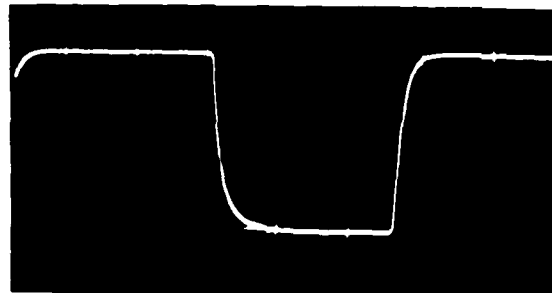

2. 100 KHz  
20 v/cm, 1  $\mu$ sec x 2

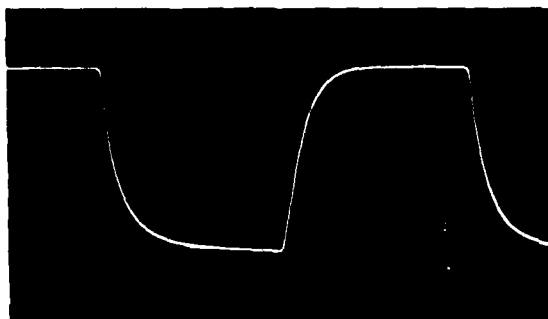

3. 200 KHz  
20 v/cm, 1  $\mu$ sec x 1

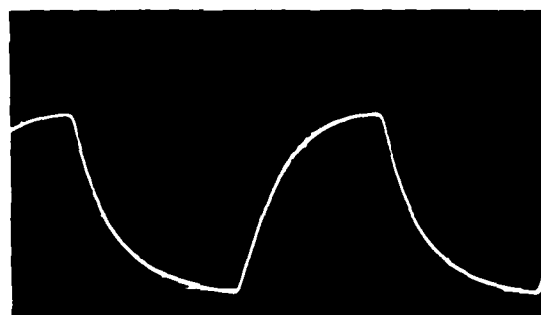

4. 500 KHz  
20 v/cm, .1  $\mu$ sec x 5

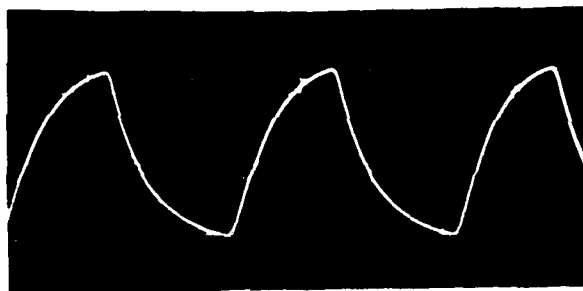

5. 650 KHz  
20 v/cm, .1  $\mu$ sec x 5

Figure 6  
Square Wave Test  
1.5KC51 ( $V_B$  52.65) Mounted in LPM 9455A

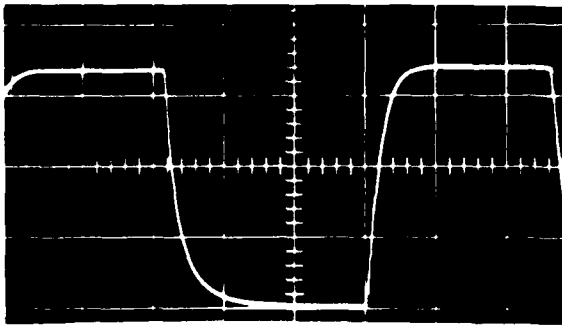

1. 100 KHz  
10 v/cm, 1  $\mu$ sec x 2

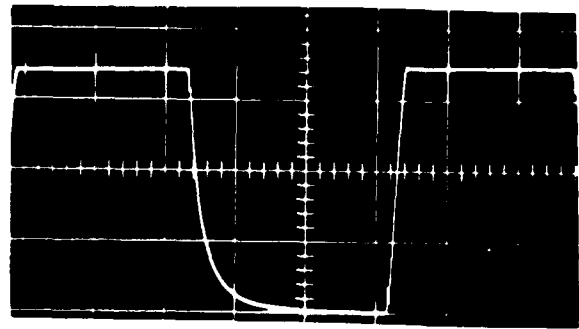

2. 100 KHz (Showing Clipping)  
10 v/cm, 1  $\mu$ sec x 2

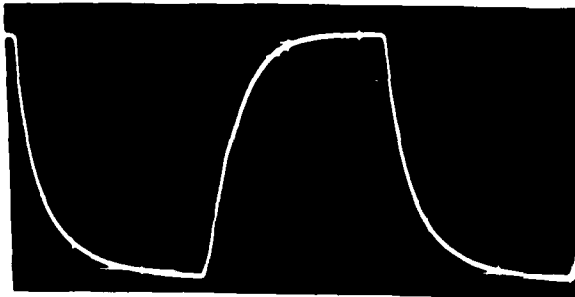

3. 200 KHz  
10 v/cm, 1  $\mu$ sec x 1

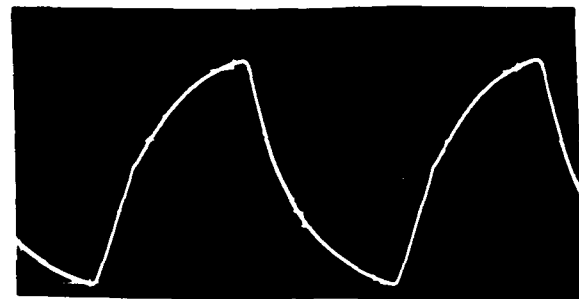

4. 500 KHz  
10 v/cm, .1  $\mu$ sec x 5

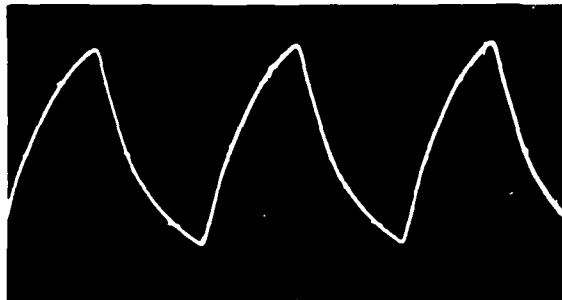

5. 750 KHz  
10 v/cm, .1  $\mu$ sec x 1

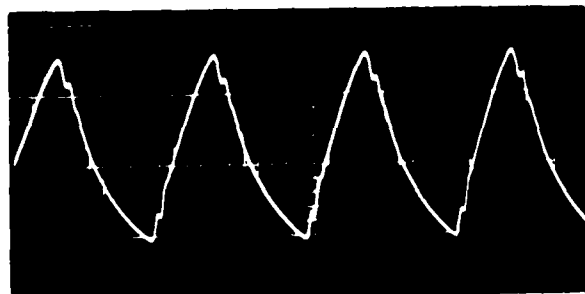

6. 1000 KHz  
10 v/cm, .1  $\mu$ sec x 5

Figure 7  
Square Wave Test  
GZ 92111A ( $V_B$  35.1v) Mounted in LPM 9455A

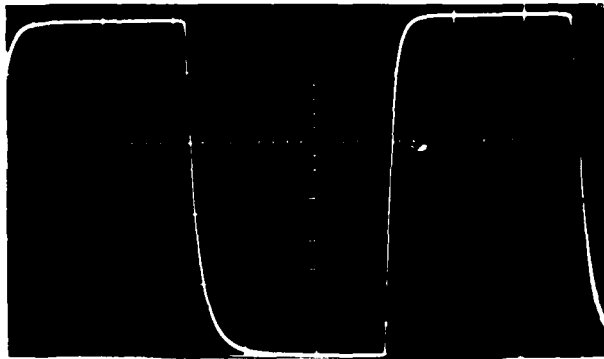

1. 100 KHz  
10 v/cm, 1  $\mu$ sec x 2

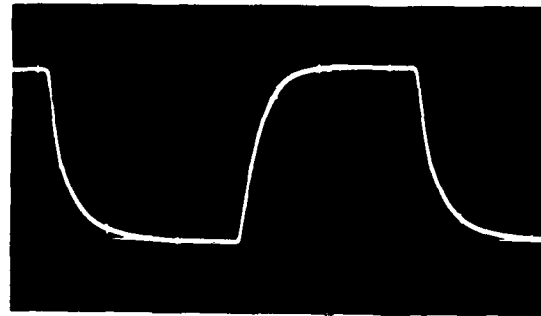

2. 200 KHz  
20 v/cm, 1  $\mu$ sec x 1

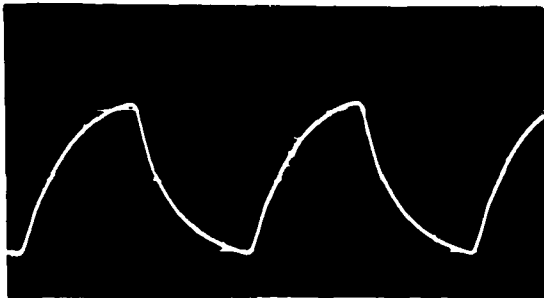

3. 650 KHz  
20 v/cm, .1  $\mu$ sec x 5

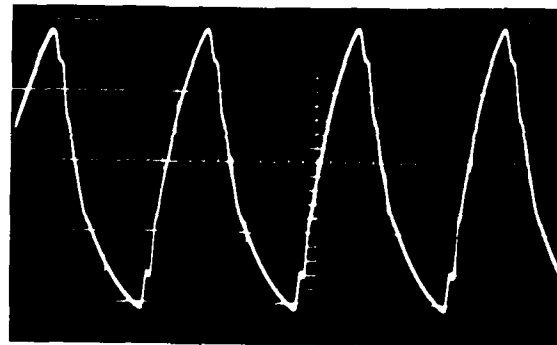

4. 1000 KHz  
10 v/cm, .1  $\mu$ sec x 5

Figure 8  
GZ 92111B ( $V_B$  50.4) Mounted in LPM 9455A

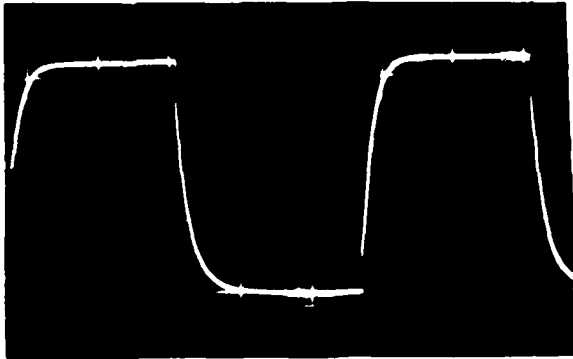

1. 10 KHz  
2 v/cm, 10  $\mu$ sec x 2

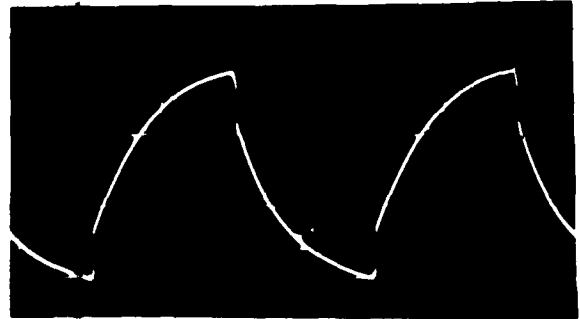

2. 50 KHz  
2 v/cm, 1  $\mu$ sec x 5



3. 200 KHz  
2 v/cm, 1  $\mu$ sec x 2

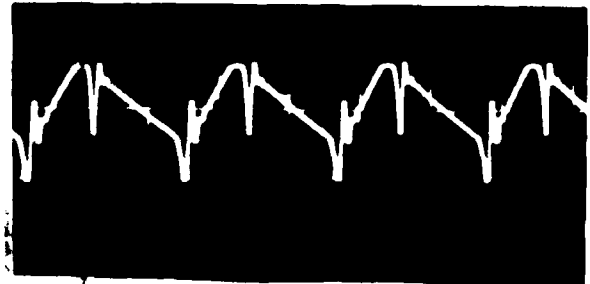

4. 1000 KHz  
2 v/cm, .1  $\mu$ sec x 5

Figure 9  
GZ 60316B ( $V_B$  6.8v) Mounted in LPM 9455A

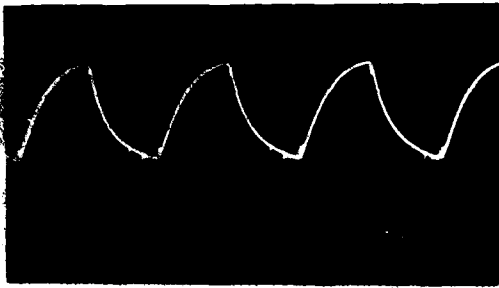

1. 1.5KC7.5 100 KHz  
5 v/cm, 1  $\mu$ sec x 5

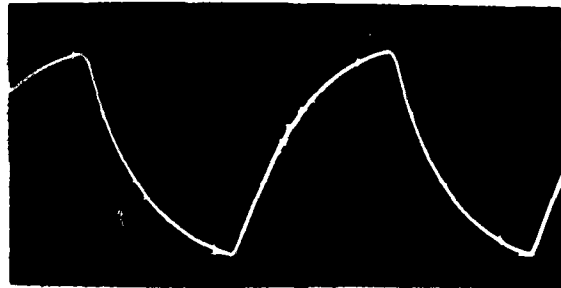

2. 1.5KC36 500 KHz  
10 v/cm, .1  $\mu$ sec x 5

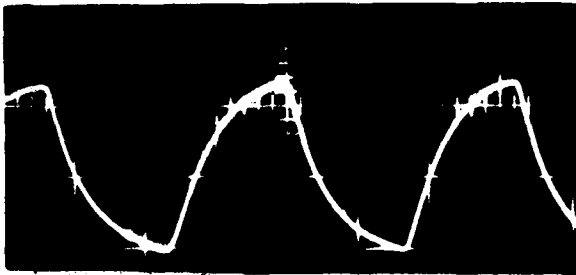

3. 1.5KC51 650 KHz  
20 v/cm, .1  $\mu$ sec x 5

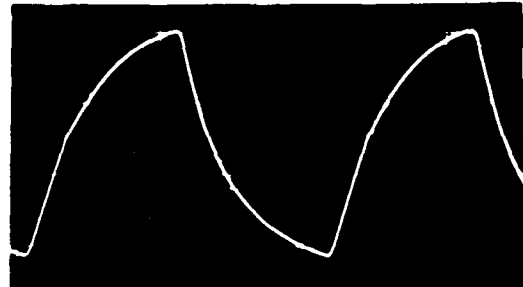

4. GZ92111A 500 KHz  
10 v/cm, .1  $\mu$ sec x 5

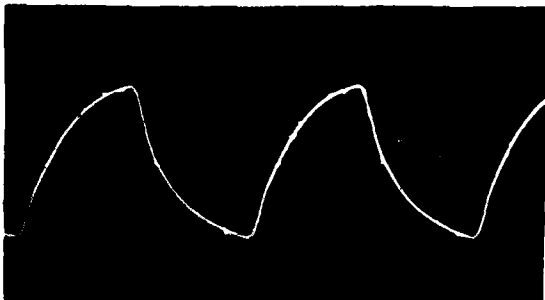

5. GZ92111B 650 KHz  
20 v/cm, .1  $\mu$ sec x 5

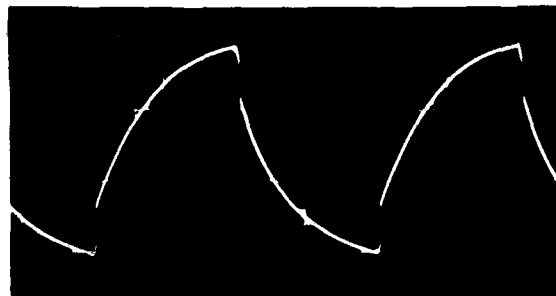

6. GZ60316B 50 KHz  
2 v/cm, 1  $\mu$ sec x 5

Figure 10

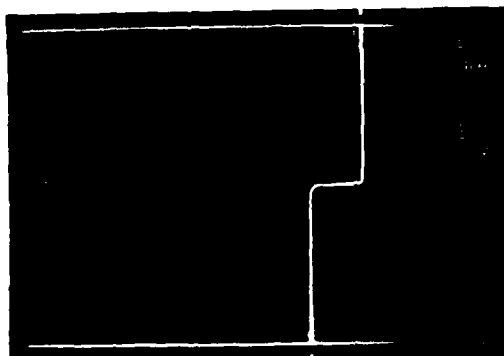

A

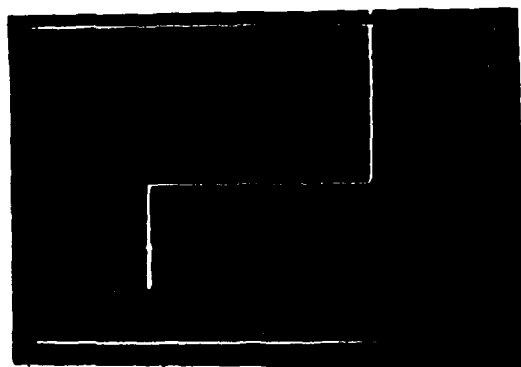

B

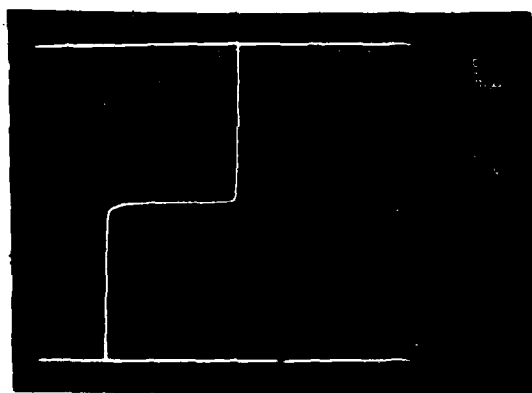

C

Figure 11

Zener Curves  
A and C GZ60316B  
B GZ92111A

### 2.1.2 Surge Tests

Surge testing was performed using a laboratory fabricated generator, courtesy of G.K. Huddleston, Georgia Institute of Technology. The basic test circuit is shown in Figure 12.

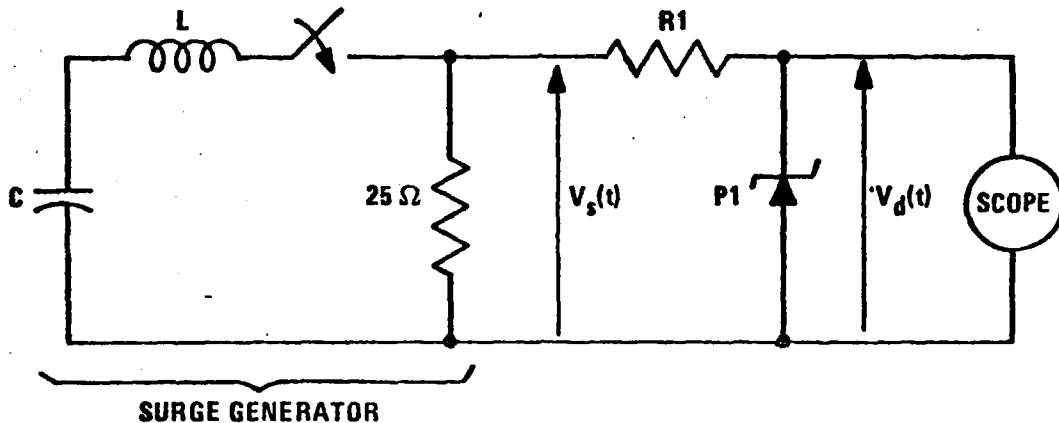

Figure 12

$C = 67.5 \text{ Mfd, } 1200 \text{ Volt}$   
 $V_s = 1000 \text{ Volts}$

$V_D = \text{Dependent on device}$   
 $R_1 = 120 \Omega$

Figure 13 shows a typical response curve, effectively a 10 X 1000 waveform.



200 Volts/cm  
1 millisecond/cm

Figure 13

The output of the surge generator was connected to the barrier strip through an 18" length of RG58 coaxial cable. The oscilloscope, barrier strip and surge generator shared a common ground. Tests were conducted using a representative group of leadless TransZorbs with the conical coil spring internal contact furnished with the LPMs.



A. 1.5 KC 7.5 5 V/cm

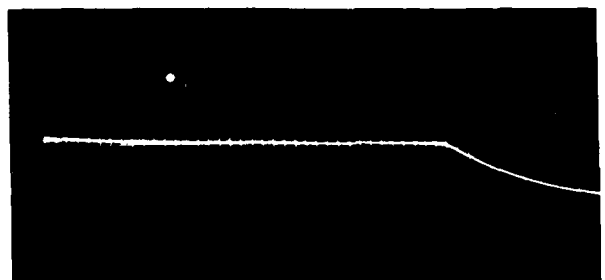

B. 1.5 KC 7.5C 5 V/cm

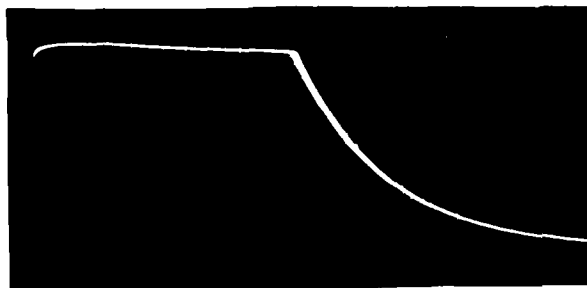

C. 1.5 KC 36 10 V/cm

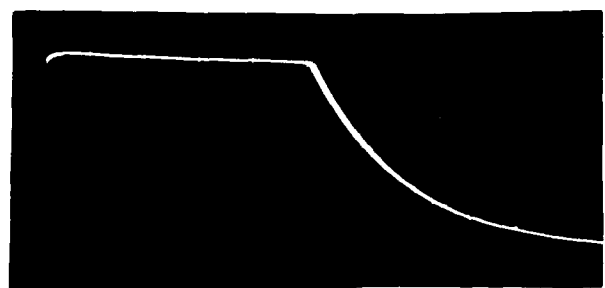

D. 1.5 KC 36C 10 V/cm



E. 1.5 KC 51 20 V/cm

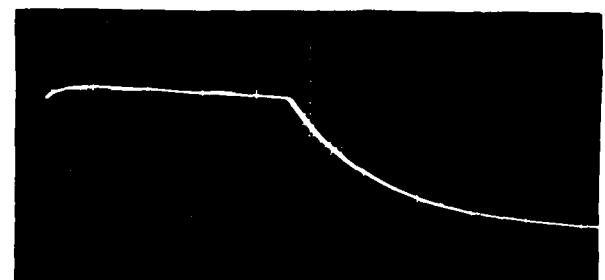

F. 1.5 KC 51C 20 V/cm

Figure 14

Stock TransZorbs (C= Bipolar)  
 Mounted in FA9455A  
 $V_s + 1000$  Volts  $R_1 = 120\Omega$

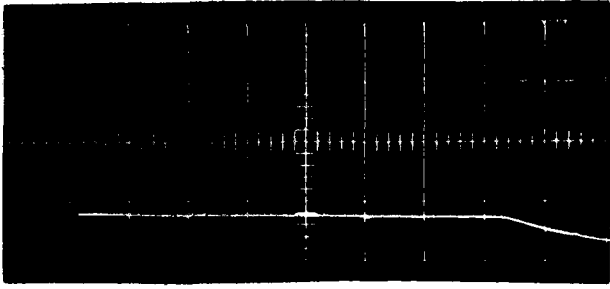

A. GZ60316B 10 V/cm

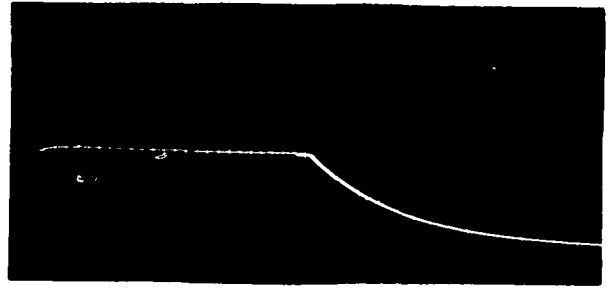

B. GZ92111A 20 V/cm

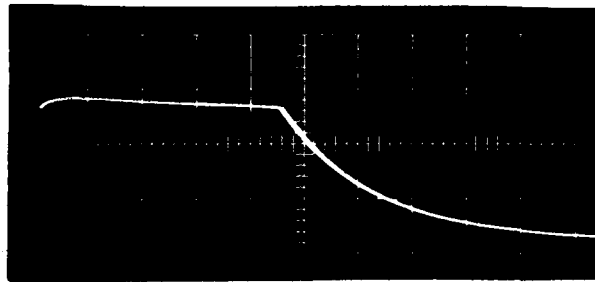

C. GZ92111B 20 V/cm

Figure 15

Low Capacity Unipolar Units  
Mounted in FA9455A  
 $V_s = 1000$  Volts       $R_1 = 120\Omega$

Also tested were two Joslyn leadless gas tube suppressors and two transient suppressors with leads. All results are shown graphically in the following series of photographs. It can be seen that all units clamped essentially within tolerance limits.

The discharge curves for the unipolar and bipolar devices are essentially the same. Apparent differences in peak values can be attributed to jitter in the vertical amplifier of the oscilloscope.

Two devices with leads were connected using maximum lead length, totaling 2 inches. Results are pictured in Figure 16. Note the accentuated peak occurring in the first millisecond of clamping.

As shown in Figure 17 gas tube devices essentially show a short circuit during conduction. When conduction ceases, voltage rises to the point determined by the discharge characteristic. For low voltage circuit protection they are normally used in combination with a silicon avalanche diode or devices with similar low voltage protection capability. The FA9455 LPMs will readily accept the Joslyn two electrode miniature gas tube surge protectors and those of other manufacturers with similar dimensions.

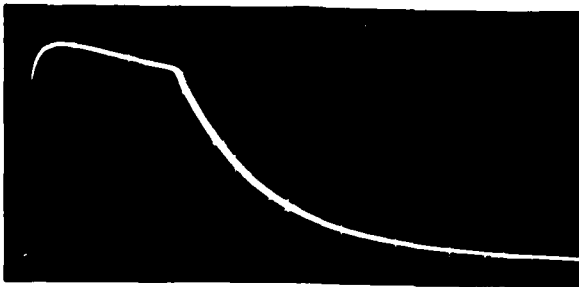

A. 1N5662A 50 V/cm

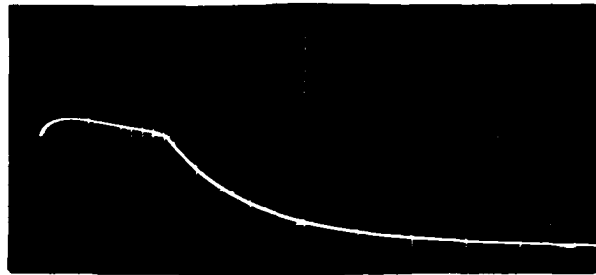

B. 1.5 KE200CA 100 V/cm

Figure 16

Avalanche Diodes With Leads  
 $V_s = 1000$  Volts  $R_1 = 120\Omega$

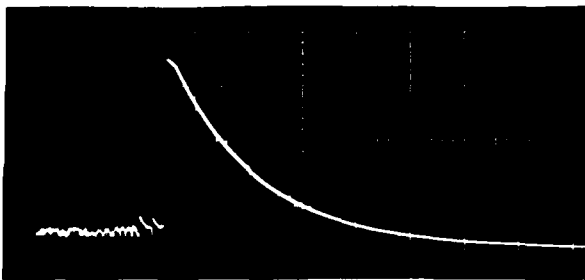

A. Joslyn 2022-12\* 50 V/cm

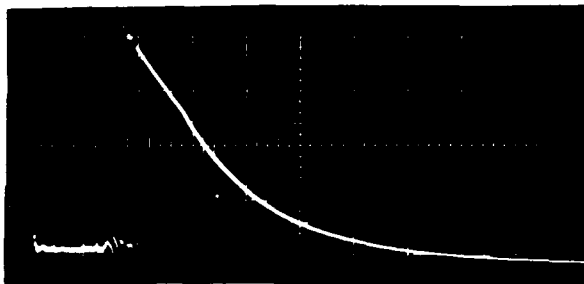

B. Joslyn 2021-12\* 50 V/cm

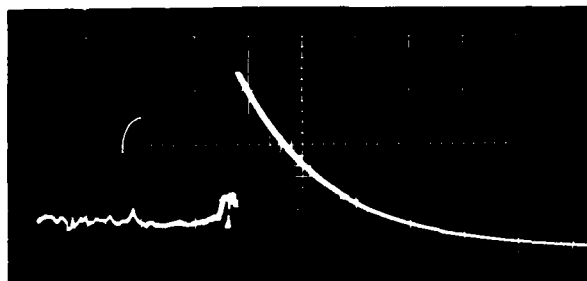

C. NE-51 20 V/cm

Figure 17

Gas Tube Devices in FA9455A  
 $V_s = 1000$  Volts  $R_1 = 120\Omega$

\* Leads Removed

## 2.2 Lightning Protection Module, Coaxial, FA9479

### 2.2.1 Insertion Loss Tests

The coaxial module alone and in combination was tested for insertion loss at frequencies ranging from 10 MHz to 1 GHz. The devices used in conjunction with the module were pairs; GZ60316B,  $V_b$  6.8v nominal; GZ92111A, 36v nominal; and GZ92111B,  $V_b$  51v nominal. Tests were performed on a Hewlett Packard 8507B Automatic Network Analyzer through the courtesy of the Harris Corporation. Results are tabulated in Tables 1, 2, 3, and 4. Table 5 is the calibration check. Results are plotted graphically in Figures 18, 19, 20 and 21. The GZ92111A's and GZ92111B's both exhibit smooth rising curves with the higher voltage device exhibiting less loss because of its lower junction capacitance. The much lower voltage GZ60316B Figure 21, has a sharply pronounced peak loss at approximately 370 MHz indicative of leakage and a possible resonance in the low capacity diode circuit incorporated in the device.

Depending on application, either insertion loss or VSWR may be used as the criteria for maximum usable frequency. An insertion loss of 3db or a VSWR of 1.5 to 1 are commonly used (but not equivalent) limits, 3db being the half power point while a VSWR of 1.5 to 1 yields 96% power transmission. Referring to the printouts from the Network Analyzer note that the insertion (transmission) loss is provided directly. VSWR is derived from the return loss using nomographs for VSWR. (3) It should be noted that the second column of the printout which identifies the transmission loss does not include the power dissipated in the device. It is not the complement of the return loss and therefore cannot be used to enter the nomograph to obtain the VSWR. (i.e., It is not the "Transmission Loss" as defined in the nomograph). The transmission loss in the column indicates the

percentage of power which gets past the LPM to the load. The method of measuring the return loss using reflected power is consistent with the requirement of the nomograph and is used to find the VSWR. For a further discussion, see Appendix A.

An insertion loss curve for a module without diodes is shown in Figure 18. Note that the module alone at one GHz shows less than 1db insertion loss. Curves for the coaxial modules with low capacity diodes are shown in Figures 19, 20 and 21. Table 6 shows the results for the module with pairs of low capacity diodes in bipolar configuration.

TABLE 6

<u>Protection</u>	<u>96% Transmission or 1.5:1 VSWR</u>	<u>50% Transmission Point or 3db Insertion Loss</u>
2 GZ60316B	30 MHz	110 MHz
2 GZ92111A	170 MHz	690 MHz
2 GZ92111B	270 MHz	850 MHz

FREQUENCY MHZ	RETURN LOSS INPUT (S11)		TRANS. LOSS FORWARD (S21)		TRANS. LOSS REVERSE (S12)		RETURN LOSS OUTPUT (S22)	
	DB	ANG	DB	ANG	DB	ANG	DB	ANG
TYPE "N" MODIFIED TEE								
10.000	42.3	-110.7	0.00	-0.7	0.00	-0.8	43.4	-81.8
35.000	35.6	-77.0	0.00	-2.6	0.00	-2.6	35.6	-72.9
60.000	31.9	-82.5	0.00	-4.4	0.00	-4.5	33.4	-109.3
85.000	28.8	-86.1	0.01	-6.3	0.01	-6.3	32.9	-148.0
110.000	26.3	-98.7	0.01	-8.1	0.02	-8.1	32.6	165.3
135.000	25.5	-114.6	0.01	-9.8	0.01	-9.8	31.4	125.6
160.000	27.5	-119.3	0.01	-11.7	0.01	-11.7	28.1	73.8
185.000	28.1	-91.3	0.01	-13.6	0.02	-13.7	26.2	23.7
210.000	23.4	-92.9	0.02	-15.5	0.03	-15.3	24.6	-26.8
235.000	21.7	-105.3	0.04	-17.3	0.04	-17.4	22.9	-66.9
260.000	21.7	-110.3	0.04	-19.1	0.04	-19.2	21.2	-97.3
285.000	21.2	-105.9	0.05	-21.0	0.05	-21.0	19.8	-123.1
310.000	20.0	-104.2	0.06	-22.9	0.06	-22.9	19.0	-150.1
335.000	19.0	-101.9	0.08	-24.9	0.08	-24.9	18.3	-176.0
360.000	17.7	-100.4	0.09	-26.2	0.09	-26.1	18.4	154.8
385.000	16.6	-103.0	0.10	-28.7	0.10	-28.1	18.3	119.1
410.000	15.7	-105.1	0.11	-30.9	0.13	-29.9	18.4	76.3
435.000	14.4	-110.1	0.14	-32.9	0.14	-32.6	18.6	31.4
460.000	13.6	-119.8	0.18	-34.9	0.18	-34.8	19.1	-13.5
485.000	14.2	-128.5	0.17	-36.7	0.18	-36.5	18.5	-46.2
510.000	15.2	-128.9	0.18	-38.6	0.17	-38.5	17.0	-76.0
535.000	14.9	-124.1	0.21	-40.7	0.21	-40.7	14.8	-106.8
560.000	14.0	-124.1	0.26	-42.5	0.26	-42.6	13.1	-138.6
585.000	13.2	-123.0	0.27	-44.2	0.28	-44.5	12.2	-168.0
610.000	11.8	-124.8	0.30	-46.1	0.31	-46.3	11.6	165.5
635.000	10.9	-133.6	0.34	-47.5	0.33	-47.8	10.8	138.6
660.000	11.3	-141.8	0.31	-49.2	0.32	-49.6	10.7	106.7
685.000	12.1	-141.8	0.33	-51.5	0.34	-51.6	11.0	70.8
710.000	11.9	-139.4	0.39	-53.7	0.41	-53.7	11.8	33.8
735.000	11.7	-142.0	0.42	-55.6	0.42	-55.4	12.4	-2.5
760.000	12.1	-141.7	0.45	-57.7	0.45	-57.5	12.1	-39.2
785.000	11.8	-135.2	0.48	-59.8	0.49	-59.6	11.4	-77.1
810.000	10.6	-135.7	0.54	-61.7	0.55	-61.7	10.4	-116.2
835.000	10.0	-139.9	0.59	-63.7	0.61	-63.6	9.4	-152.5
860.000	9.4	-142.6	0.62	-65.4	0.64	-65.4	8.6	175.1
885.000	8.9	-147.1	0.65	-67.5	0.66	-67.4	7.8	144.2
910.000	8.7	-151.3	0.69	-69.6	0.69	-69.6	7.4	113.6
935.000	8.9	-153.2	0.74	-71.7	0.74	-71.6	7.4	83.9
960.000	8.6	-153.8	0.82	-73.9	0.83	-73.9	7.7	53.9
985.000	8.6	-155.6	0.91	-75.3	0.93	-76.0	8.0	22.7

Table 1

FREQUENCY MHZ	RETURN LOSS INPUT (S11)		TRANS. LOSS FORWARD (S21)		TRANS. LOSS REVERSE (S12)		RETURN LOSS OUTPUT (S22)	
	DB	ANG	DB	ANG	DB	ANG	DB	ANG
GZ 92111A								
10.000	26.2	-119.6	0.19	-2.7	0.20	-2.8	25.5	-119.1
30.000	20.4	-128.3	0.50	-5.9	0.50	-6.0	20.1	-129.5
50.000	17.8	-134.9	0.76	-8.0	0.76	-8.0	17.9	-135.6
70.000	16.4	-140.7	0.95	-9.7	0.96	-9.7	16.6	-139.5
90.000	15.9	-144.9	1.00	-11.0	1.09	-10.9	15.7	-142.5
110.000	15.4	-146.5	1.17	-12.5	1.17	-12.4	15.1	-145.4
130.000	14.9	-147.3	1.25	-13.9	1.24	-13.7	14.8	-147.9
150.000	14.3	-148.9	1.31	-15.1	1.30	-15.1	14.6	-149.2
170.000	14.1	-150.3	1.34	-16.7	1.34	-16.7	14.4	-150.0
190.000	13.9	-150.3	1.40	-18.2	1.39	-18.2	14.0	-149.8
210.000	13.5	-150.1	1.45	-19.8	1.45	-19.7	13.5	-149.9
230.000	13.0	-151.2	1.49	-21.2	1.49	-21.1	13.1	-150.1
250.000	12.7	-152.2	1.52	-22.6	1.53	-22.6	12.7	-151.0
270.000	12.4	-152.2	1.57	-24.2	1.58	-24.2	12.2	-151.5
290.000	12.1	-152.9	1.63	-25.8	1.62	-25.8	11.9	-152.2
310.000	11.8	-153.2	1.68	-27.3	1.67	-27.3	11.5	-152.5
330.000	11.4	-153.9	1.72	-28.8	1.72	-28.8	11.2	-153.2
350.000	11.0	-154.5	1.77	-30.5	1.77	-30.5	11.0	-153.7
370.000	10.7	-155.0	1.83	-32.0	1.83	-31.9	10.6	-154.3
390.000	10.4	-155.8	1.89	-33.6	1.89	-33.6	10.4	-154.8
410.000	10.0	-156.8	1.94	-35.2	1.94	-35.1	10.1	-155.7
430.000	9.8	-157.9	1.99	-36.8	1.99	-36.8	9.9	-156.6
450.000	9.5	-159.5	2.07	-38.4	2.05	-38.5	9.6	-157.9
470.000	9.3	-160.1	2.12	-40.0	2.11	-40.0	9.5	-158.9
490.000	9.0	-160.5	2.19	-41.6	2.18	-41.6	9.2	-160.0
510.000	8.7	-161.5	2.25	-43.2	2.25	-43.1	9.0	-160.9
530.000	8.4	-163.0	2.32	-44.1	2.33	-44.7	8.7	-161.8
550.000	8.2	-164.3	2.39	-45.7	2.40	-46.1	8.4	-163.0
570.000	7.9	-165.8	2.50	-47.2	2.49	-47.7	8.2	-164.7
590.000	7.6	-167.7	2.59	-48.7	2.57	-48.7	7.9	-166.2
610.000	7.5	-169.9	2.67	-50.2	2.65	-50.2	7.7	-167.6
630.000	7.4	-170.5	2.76	-51.6	2.76	-51.7	7.5	-168.8
650.000	7.3	-171.1	2.85	-52.9	2.84	-53.1	7.2	-169.7
670.000	7.0	-172.2	2.94	-54.5	2.94	-54.7	7.1	-170.8
690.000	6.8	-173.6	3.00	-56.8	3.01	-56.4	6.8	-172.6
710.000	6.6	-175.1	3.11	-58.6	3.12	-58.0	6.7	-173.6
730.000	6.4	-176.2	3.22	-60.2	3.21	-59.5	6.6	-175.0
750.000	6.2	-178.0	3.33	-62.0	3.32	-61.3	6.4	-176.3
770.000	6.0	179.9	3.45	-63.6	3.45	-63.4	6.3	-177.5
790.000	5.9	178.4	3.57	-65.4	3.57	-65.2	6.1	-178.8
810.000	5.8	177.2	3.71	-67.0	3.71	-66.6	5.8	179.7
830.000	5.6	175.7	3.85	-68.4	3.84	-68.1	5.6	178.2
850.000	5.5	174.1	3.98	-69.9	3.99	-69.4	5.5	176.3
870.000	5.3	172.8	4.12	-71.5	4.12	-71.0	5.3	174.7
890.000	5.2	171.4	4.25	-72.7	4.25	-72.3	5.1	173.0
910.000	4.9	170.1	4.38	-74.1	4.38	-73.7	5.0	171.5
930.000	4.7	167.9	4.55	-75.6	4.55	-75.3	4.8	169.8
950.000	4.6	166.0	4.71	-76.9	4.72	-76.8	4.6	168.2
970.000	4.5	164.1	4.89	-78.4	4.91	-78.2	4.5	166.5
990.000	4.3	162.3	5.10	-79.7	5.11	-79.6	4.4	165.0

Table 2

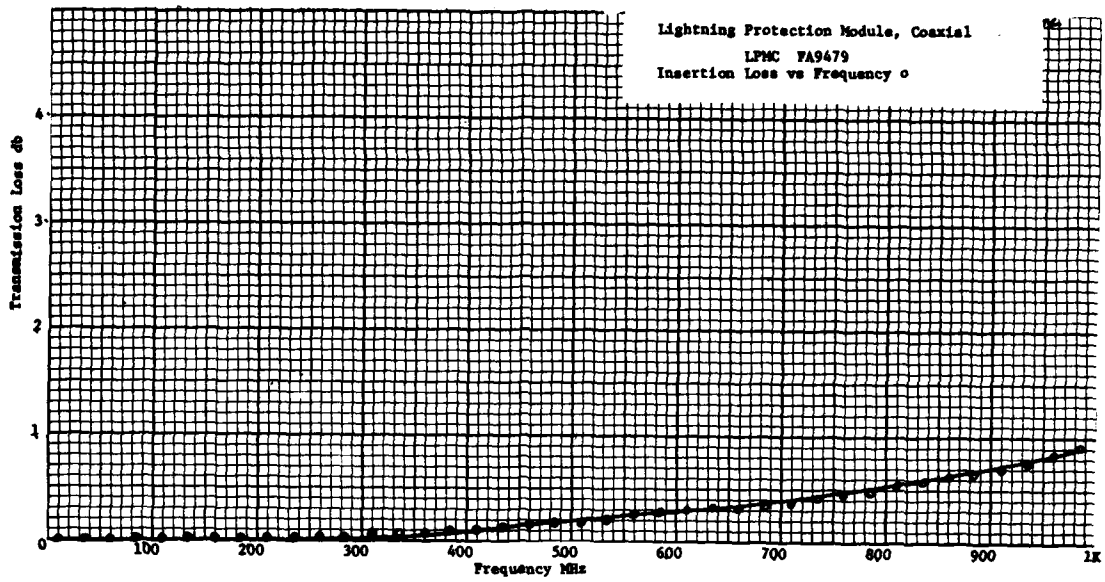

Figure 18

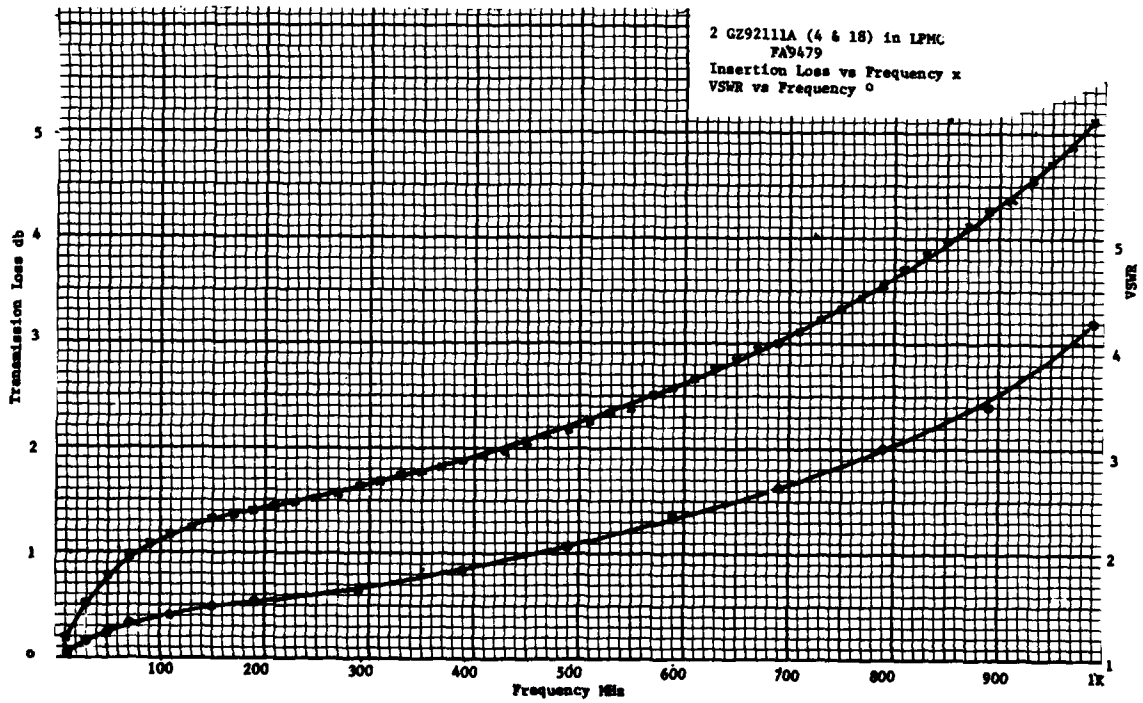

Figure 19

FREQUENCY MHZ	RETURN LOSS INPUT (S11)		TRANS. LOSS FORWARD (S21)		TRANS. LOSS REVERSE (S12)		RETURN LOSS OUTPUT (S22)	
	DB	ANG	DB	ANG	DB	ANG	DB	ANG
GZ 92111B								
10.000	29.4	-115.3	0.11	-2.1	0.12	-2.1	28.4	-115.0
30.000	23.2	-123.5	0.33	-4.9	0.33	-5.0	22.9	-125.2
50.000	20.4	-130.0	0.51	-6.6	0.51	-6.7	20.5	-130.7
70.000	19.0	-135.4	0.63	-8.2	0.64	-8.3	19.2	-133.7
90.000	18.4	-139.2	0.72	-9.6	0.72	-9.6	18.3	-135.7
110.000	17.9	-139.5	0.77	-11.3	0.77	-11.2	17.6	-138.3
130.000	17.2	-139.4	0.82	-12.8	0.81	-12.7	17.1	-140.5
150.000	16.6	-140.7	0.85	-14.1	0.85	-14.1	16.9	-141.3
170.000	16.3	-141.7	0.87	-15.6	0.87	-15.6	16.6	-141.2
190.000	15.9	-141.0	0.91	-17.2	0.90	-17.2	16.1	-140.4
210.000	15.4	-140.4	0.94	-18.8	0.94	-18.8	15.5	-140.0
230.000	14.8	-141.6	0.98	-20.3	0.98	-20.4	14.9	-140.2
250.000	14.5	-142.4	1.00	-21.9	1.01	-21.9	14.3	-141.1
270.000	14.1	-142.3	1.04	-23.5	1.05	-23.5	13.8	-141.8
290.000	13.6	-142.7	1.09	-25.2	1.09	-25.2	13.3	-142.5
310.000	13.1	-143.2	1.12	-26.8	1.11	-26.8	12.8	-143.0
330.000	12.6	-144.1	1.16	-28.3	1.16	-28.4	12.4	-143.7
350.000	12.2	-144.7	1.21	-30.0	1.20	-30.0	12.1	-144.1
370.000	11.9	-145.4	1.25	-31.6	1.25	-31.6	11.7	-144.8
390.000	11.5	-146.3	1.29	-33.4	1.30	-33.4	11.4	-145.4
410.000	11.1	-147.7	1.34	-34.9	1.35	-34.9	11.1	-146.3
430.000	10.7	-149.0	1.38	-36.6	1.38	-36.6	10.8	-147.3
450.000	10.4	-150.7	1.44	-38.2	1.43	-38.2	10.6	-148.6
470.000	10.2	-151.3	1.48	-39.9	1.47	-39.9	10.3	-149.7
490.000	9.8	-151.7	1.54	-41.4	1.54	-41.4	10.1	-150.8
510.000	9.4	-152.8	1.59	-43.0	1.58	-43.0	9.8	-151.7
530.000	9.1	-154.5	1.64	-44.1	1.65	-44.8	9.5	-152.7
550.000	8.8	-156.0	1.71	-45.8	1.73	-46.2	9.1	-154.1
570.000	8.6	-157.6	1.79	-47.3	1.79	-47.8	8.8	-156.0
590.000	8.3	-159.6	1.87	-48.8	1.86	-48.8	8.5	-157.7
610.000	8.2	-162.0	1.93	-50.5	1.92	-50.4	8.3	-159.2
630.000	8.1	-162.4	2.01	-51.9	2.02	-52.0	8.1	-160.4
650.000	7.9	-162.7	2.09	-53.3	2.08	-53.5	7.9	-161.4
670.000	7.5	-163.8	2.15	-54.9	2.15	-55.1	7.6	-162.3
690.000	7.3	-165.4	2.20	-57.4	2.21	-57.0	7.4	-164.2
710.000	7.2	-166.7	2.29	-59.1	2.30	-58.6	7.1	-165.7
730.000	6.9	-167.9	2.38	-61.0	2.37	-60.3	6.9	-166.6
750.000	6.6	-170.1	2.47	-62.7	2.45	-62.4	6.9	-168.0
770.000	6.5	-172.2	2.55	-64.7	2.55	-63.9	6.7	-169.9
790.000	6.4	-173.6	2.65	-66.6	2.66	-66.3	6.5	-170.2
810.000	6.3	-174.7	2.77	-68.3	2.77	-67.9	6.3	-171.7
830.000	6.1	-176.0	2.88	-69.9	2.87	-69.6	6.0	-173.5
850.000	5.9	-177.6	2.99	-71.4	2.99	-71.0	5.8	-175.2
870.000	5.7	-178.9	3.09	-73.3	3.10	-72.8	5.7	-176.9
890.000	5.5	179.9	3.21	-74.7	3.21	-74.2	5.5	-178.5
910.000	5.3	178.4	3.32	-76.3	3.32	-75.9	5.3	179.9
930.000	5.1	176.2	3.45	-78.0	3.44	-77.7	5.1	178.2
950.000	4.9	174.3	3.58	-79.6	3.58	-79.5	4.9	176.5
970.000	4.8	172.5	3.71	-81.4	3.74	-81.3	4.8	175.0
990.000	4.6	170.8	3.89	-83.2	3.91	-83.0	4.6	173.5

Table 3

FREQUENCY MHZ	RETURN LOSS INPUT (S11)		TRANS. LOSS FORWARD (S21)		TRANS. LOSS REVERSE (S12)		RETURN LOSS OUTPUT (S22)	
	DB	ANG	DB	ANG	DB	ANG	DB	ANG
GZ 60316B								
10.000	20.7	-108.8	0.22	-5.2	0.22	-5.3	20.4	-109.5
30.000	13.2	-115.5	0.64	-13.3	0.63	-13.4	13.2	-116.7
50.000	9.7	-122.1	1.12	-20.5	1.11	-20.5	9.7	-122.9
70.000	7.6	-128.9	1.68	-26.8	1.68	-27.1	7.5	-129.2
90.000	6.2	-135.0	2.28	-32.7	2.31	-32.7	6.0	-134.9
110.000	5.1	-140.6	2.98	-38.3	2.99	-38.1	5.0	-140.9
130.000	4.2	-146.2	3.75	-43.2	3.73	-42.9	4.2	-146.2
150.000	3.6	-151.2	4.48	-47.0	4.45	-47.0	3.6	-150.7
170.000	3.0	-156.1	5.34	-51.1	5.33	-51.2	3.1	-155.6
190.000	2.6	-160.6	6.33	-54.5	6.32	-54.5	2.6	-160.2
210.000	2.2	-165.2	7.40	-57.2	7.40	-57.2	2.3	-164.7
230.000	1.9	-169.3	8.54	-59.0	8.55	-58.9	2.0	-169.0
250.000	1.7	-173.5	9.79	-60.0	9.81	-59.9	1.7	-173.1
270.000	1.5	-177.5	11.18	-60.1	11.18	-59.9	1.5	-177.0
290.000	1.4	178.8	12.61	-58.2	12.71	-58.2	1.4	179.2
310.000	1.3	175.6	14.21	-54.1	14.26	-54.3	1.3	175.6
330.000	1.2	171.4	15.88	-46.5	15.95	-46.6	1.2	172.1
350.000	1.1	168.0	17.38	-34.6	17.35	-34.7	1.1	168.7
370.000	1.0	164.5	18.08	-18.5	18.15	-18.5	1.1	165.3
390.000	1.0	161.1	17.76	-2.0	17.82	-2.0	1.0	162.0
410.000	1.0	157.9	16.64	10.9	16.69	10.9	1.0	158.7
430.000	1.0	154.8	15.29	19.2	15.23	19.2	1.0	155.5
450.000	1.1	151.6	13.92	24.0	13.86	24.0	1.0	152.5
470.000	1.1	149.1	12.63	25.9	12.56	26.5	1.1	149.5
490.000	1.2	146.3	11.47	27.3	11.51	27.1	1.1	146.7
510.000	1.2	143.3	10.48	27.3	10.52	27.3	1.2	143.7
530.000	1.3	140.4	9.52	27.3	9.58	26.7	1.2	140.9
550.000	1.4	137.6	8.75	26.2	8.73	26.0	1.3	138.3
570.000	1.4	134.6	8.05	25.0	8.05	24.6	1.4	135.5
590.000	1.6	132.0	7.42	23.5	7.35	23.4	1.5	133.5
610.000	1.7	129.6	6.78	21.6	6.83	21.7	1.6	130.8
630.000	1.8	127.4	6.34	20.0	6.29	19.9	1.8	128.3
650.000	1.9	124.9	5.83	18.3	5.86	18.0	1.9	125.8
670.000	2.0	121.7	5.46	16.1	5.47	15.9	2.0	123.2
690.000	2.2	118.9	5.06	13.6	5.07	13.6	2.2	120.3
710.000	2.3	116.3	4.72	11.3	4.71	11.3	2.3	117.9
730.000	2.5	113.8	4.42	8.9	4.39	8.9	2.5	115.8
750.000	2.8	111.7	4.10	6.6	4.11	6.4	2.6	113.5
770.000	3.0	110.4	3.85	4.2	3.87	4.2	2.8	111.3
790.000	3.1	108.8	3.59	1.9	3.61	2.0	3.0	109.2
810.000	3.3	106.8	3.35	-0.4	3.35	-0.3	3.2	107.0
830.000	3.4	104.7	3.12	-2.5	3.11	-2.5	3.4	104.9
850.000	3.6	102.6	2.90	-4.9	2.90	-4.8	3.6	103.1
870.000	3.7	100.3	2.68	-7.2	2.68	-7.1	3.9	101.4
890.000	3.9	98.0	2.47	-9.2	2.46	-9.2	4.1	99.5
910.000	4.2	95.8	2.28	-11.6	2.28	-11.7	4.3	97.7
930.000	4.4	94.6	2.13	-13.9	2.13	-13.9	4.5	95.8
950.000	4.7	93.2	1.98	-16.2	2.00	-16.3	4.8	93.8
970.000	4.9	91.7	1.85	-18.5	1.88	-18.5	5.0	92.1
990.000	5.1	89.6	1.76	-20.6	1.76	-20.6	5.2	90.1

Table 4

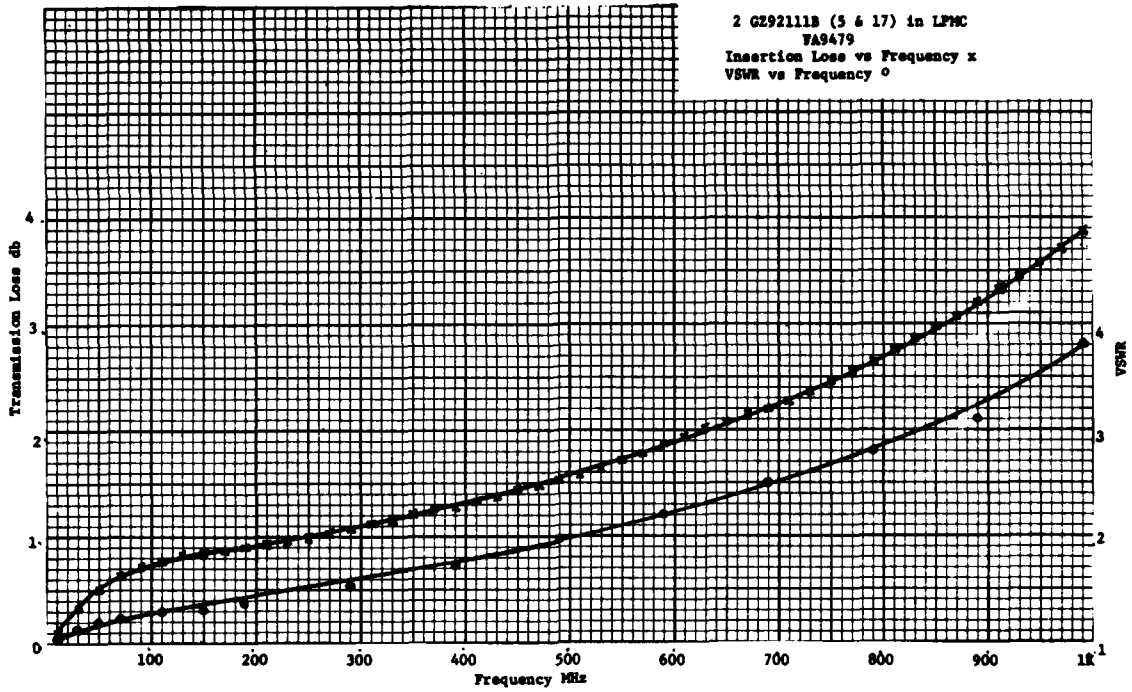

Figure 20

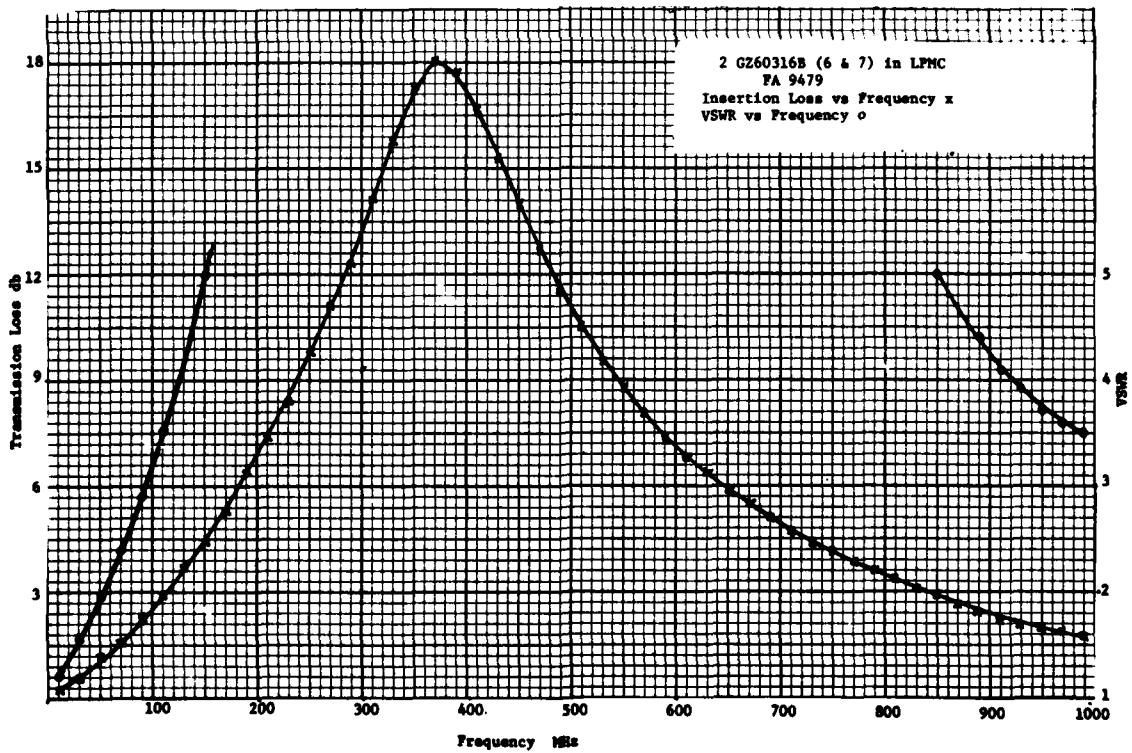

Figure 21

FREQUENCY MHZ	RETURN LOSS INPUT (S11)		TRANS. LOSS FORWARD (S21)		TRANS. LOSS REVERSE (S12)		RETURN LOSS OUTPUT (S22)	
	DB	ANG	DB	ANG	DB	ANG	DB	ANG
CALIBRATION CHECK (THRU)								
10.000	47.7	-121.1	0.01	-0.0	0.01	-0.0	41.5	-112.8
30.000	49.5	-64.1	0.00	0.1	0.01	-0.0	44.6	-105.4
50.000	42.2	-76.7	0.00	0.1	0.01	-0.0	42.7	-74.9
70.000	40.2	-100.4	0.00	-0.0	0.01	-0.1	38.8	-68.9
90.000	44.5	-118.9	0.01	0.1	0.01	0.1	37.5	-75.5
110.000	48.0	-84.7	0.01	-0.0	0.00	0.1	37.9	-88.9
130.000	41.3	-81.2	0.00	-0.0	0.00	0.1	41.1	-104.5
150.000	39.1	-100.0	0.01	0.0	0.01	0.0	44.4	-114.3
170.000	41.9	-117.9	0.01	0.0	0.01	0.0	57.5	-102.1
190.000	45.5	-94.2	0.01	-0.0	0.00	-0.0	48.6	-63.7
210.000	40.2	-80.0	0.01	-0.0	0.01	-0.0	42.5	-69.8
230.000	37.9	-99.1	0.01	-0.0	0.01	0.1	38.1	-83.9
250.000	39.5	-110.4	0.01	0.1	0.02	0.0	35.3	-93.7
270.000	39.5	-92.7	0.01	0.0	0.02	0.0	33.8	-97.7
290.000	37.5	-82.1	0.02	0.0	0.02	0.0	33.1	-98.4
310.000	35.7	-87.0	0.02	-0.0	0.01	0.1	31.3	-95.0
330.000	33.2	-89.3	0.01	-0.0	0.01	-0.0	30.8	-92.4
350.000	32.8	-89.0	0.02	-0.0	0.01	-0.1	30.5	-91.1
370.000	31.5	-88.4	0.03	-0.0	0.02	-0.0	30.1	-89.5
390.000	30.5	-90.3	0.03	-0.1	0.03	-0.0	30.2	-88.9
410.000	29.6	-93.2	0.03	-0.0	0.03	-0.0	30.0	-89.4
430.000	28.9	-96.7	0.03	-0.0	0.02	-0.1	30.0	-89.3
450.000	28.8	-100.9	0.04	-0.1	0.04	-0.1	30.2	-93.8
470.000	29.6	-99.2	0.04	0.0	0.03	0.0	31.2	-97.4
490.000	29.0	-89.4	0.03	-0.1	0.03	-0.1	31.5	-98.6
510.000	27.7	-85.1	0.03	-0.6	0.02	0.1	31.5	-96.9
530.000	26.6	-87.9	0.03	-0.1	0.03	-0.1	31.2	-89.8
550.000	26.3	-88.4	0.04	-0.1	0.04	-0.0	29.3	-87.6
570.000	25.4	-89.0	0.06	-0.1	0.05	-0.7	27.8	-90.3
590.000	24.4	-93.8	0.07	-0.1	0.06	-0.1	27.0	-95.0
610.000	24.6	-103.5	0.08	0.0	0.07	0.0	27.2	-98.1
630.000	26.4	-108.1	0.07	0.2	0.08	0.1	27.2	-97.6
650.000	27.6	-96.4	0.05	0.2	0.05	0.2	27.2	-92.4
670.000	26.3	-85.1	0.05	0.2	0.05	0.0	27.3	-86.7
690.000	25.7	-85.1	0.04	0.1	0.04	-0.0	26.6	-84.4
710.000	25.6	-86.3	0.05	0.0	0.05	-0.1	26.0	-86.0
730.000	25.1	-82.5	0.05	-0.0	0.05	-0.1	26.1	-89.9
750.000	23.7	-85.1	0.05	-0.1	0.05	-0.1	26.8	-92.6
770.000	23.1	-93.4	0.06	-0.1	0.06	-0.0	27.9	-91.4
790.000	23.7	-100.7	0.05	-0.1	0.05	-0.1	27.9	-87.2
810.000	24.9	-100.4	0.05	0.0	0.05	-0.1	27.1	-82.9
830.000	24.9	-98.5	0.07	0.0	0.06	-0.1	25.9	-82.2
850.000	25.1	-100.7	0.08	-0.1	0.08	0.0	25.1	-85.1
870.000	26.0	-102.0	0.08	0.0	0.08	-0.1	24.4	-87.6
890.000	26.6	-92.9	0.06	0.0	0.06	0.0	24.2	-87.9
910.000	25.5	-84.5	0.06	-0.0	0.07	-0.0	23.6	-87.4
930.000	24.3	-85.0	0.07	-0.1	0.07	-0.1	23.3	-87.3
950.000	23.5	-88.9	0.08	-0.1	0.09	-0.2	23.0	-87.7
970.000	23.2	-92.3	0.09	-0.2	0.10	-0.3	23.0	-89.3
990.000	23.1	-99.6	0.10	-0.0	0.11	-0.1	23.4	-89.5

Table 5

### 2.2.2 Surge Tests

Surge tests were performed on the coaxial module in conjunction with two GZ60316B low capacity diodes mounted back to back for bipolar action. Surge source was a Keytek Model 424 Surge Generator Monitor with both 8 X 20 and 1.2 X 50 plugin units. Results were recorded on a Tektronix Model 7834 storage oscilloscope. Tests were performed at the General Semiconductor Industries plant.

Tests 1, 2 and 3 are shown pictorially in Figure 22A. All used the 8 X 20 wave shape. The circuit was not terminated. Conical spring in the holder.

- a. 500 volts, 24 amperes, 11 volt clamp
- b. 1000 volts, 49 amperes, 12 volt clamp. With slight spike but very little difference.
- c. 1000 volts, 98 amperes. Shows bad negative excursion of approximately 10 volts. This latter probably due to heating. The device was operating beyond its limits.

Test 4, Figure 22B is a repeat of the 1000 volt at 98 amperes using a flat non-inductive spring. The clamping voltage was lowered by approximately one volt. Note negative pulse shift.

Test 5, Figure 22C used a 1.2 X 50 wave shape, applying 1000 volts at 66 amperes. The device clamped at 12 volts with no negative excursion.

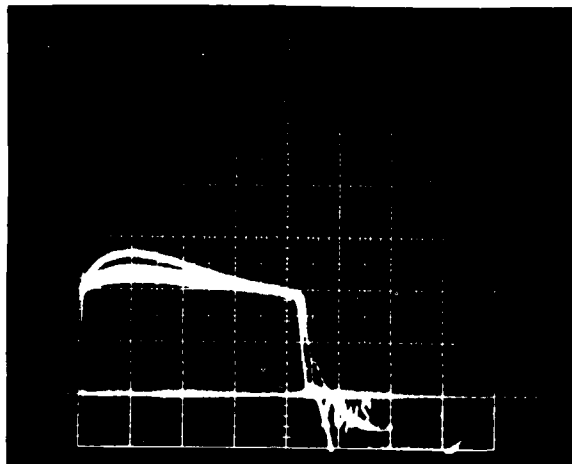

- A. Test 1. 500 Volts 24 Amperes  
 Test 2. 1000 Volts 49 Amperes  
 Test 3. 1000 Volts 98 Amperes  
 8 x 20 Waveshape

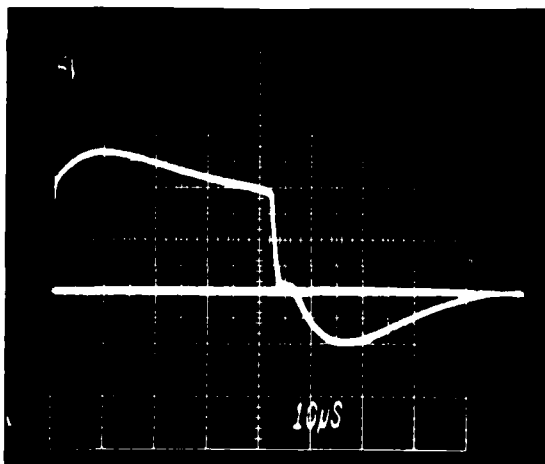

- B. Test 4. 1000 Volts 98 Amperes  
 (Non-inductive spring)  
 8 x 20 Waveshape

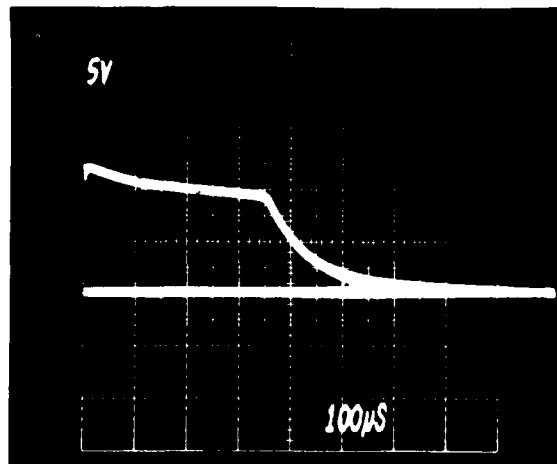

- C. Test 5. 1000 Volts 66 Amperes  
 (Non-inductive spring)  
 1.2 x 50 Waveshape

Figure 22  
 Surge Tests

2GZ60316B (Bipolar Connected) in LPMC FA9479

## CHAPTER 3

### CONCLUSION AND RECOMMENDATIONS

#### 1. Conclusion

Square wave tests on the FA9455A barrier strip type protection module, insertion loss tests on the FA9479 coaxial module and surge testing of both modules indicated that within test parameters, the modules are limited only by the characteristics and capabilities of the surge suppressor devices used. i.e., they are device limited. However, a series of tests performed by Illinois Institute of Technology, Research Institute (4) to determine effectiveness in suppressing EMP did indicate a problem in handling short, nanosecond, impulses.

#### 2. Recommendations

The conical spring used in both types of modules should be replaced with a "Belleville washer" type spring as described in the introduction and pictured in Figure 3. This will require minor modification of the caps for both devices.

## APPENDIX A

### Relationship Derivation, Transmission Loss/Return Loss

Return loss is a term used to describe the degree of mismatch introduced by a TranZorb in a coaxial line. Whereas transmission loss (or insertion loss) is defined as

$$\frac{P_{\text{transmitted}}}{P_{\text{incident}}}$$

Return loss is defined as

$$\frac{P_{\text{reflected}}}{P_{\text{incident}}}$$

Thus for a well matched line, the insertion loss in db would be close to zero, since the ratio of the transmitted to the incident power would be close to one. On the other hand, the return loss in db would be a large number, since the reflected power would be a small fraction of the incident power. Given the return loss, the transmission loss can be calculated.

Since  $P_{\text{incident}} = P_{\text{transmitted}} + P_{\text{reflected}}$ , the VSWR can be derived from the return loss as follows:

The return loss in db is defined as [5].

$$\text{Return Loss, db} = 10 \log_{10} |\Gamma|^2, \quad (1)$$

where

$$|\Gamma| = \text{magnitude of the voltage reflection coefficient.}$$

Since

$$|\Gamma| = \frac{\rho-1}{\rho+1}, \quad (2)$$

where

$$\rho = \text{VSWR}, \quad (3)$$

we can write (1) as

$$\text{Return Loss, db} = 20 \log_{10} \left( \frac{\rho-1}{\rho+1} \right). \quad (4)$$

Solving for  $\rho$

$$\rho = \frac{1 + 10^{+(\text{return loss, db})/20}}{1 - 10^{+(\text{return loss, db})/20}} \quad (5)$$

Note that the return loss is always a negative number or zero.

A similar computation can be performed to determine the VSWR from the transmission loss, using

$$\text{Transmission Loss (db)} = 10 \log (1 - |\Gamma|^2) \quad , \quad (6)$$

and solving for  $\rho$ . Care should be taken to account for the power dissipated by the device under test when using transmission loss to determine the VSWR.

## APPENDIX B

### REFERENCES

1. General Semiconductor Industries, Tempe, Arizona, Product Catalog 1978-1979.
2. Specification Sheets for low capacity transient suppressors. See Appendix C.
3. Fink, Donald G., Editor-in-Chief, Electronics Engineers' Handbook, First Edition, pp 9-5 and 9-6.
4. Illinois Institute of Technology, Research Institute, Report Project E6455 conducted under Task 3 of Sub-contract No. S-79-01001 with Florida Institute of Technology. Report dated May 1979.
5. Smith, Phillip H., "Electronic Applications of the Smith Chart", McGraw-Hill Book Company, New York, 1969, pp 37-38.

**APPENDIX C**

**SPECIFICATION SHEETS**



GENERAL SEMICONDUCTOR INDUSTRIES, INC.

TRANSZORB

TRANSIENT VOLTAGE  
SUPPRESSOR  
15K008  
THRU  
15K0110A

#### DESCRIPTION

This leadless TransZorb is designed for direct retro-fit or replacement of a gas-discharge suppressor when lower voltages are needed to protect voltage sensitive circuitry. For Bipolar applications, see notes on the reverse side.

The TransZorb has a peak pulse power rating of 1500 watts for 1 millisecond and therefore can be used in applications where induced lightning on rural or remote transmission lines present a hazard to the electronic circuitry. (Reference: R.E.A. Specification P.E. 60). The response time of TransZorb clamping action is effectively instantaneous (better than  $1 \times 10^{-12}$  sec.); therefore, they can protect Integrated Circuits, MOS devices, Hybrids and other voltage-sensitive semiconductors and components. TransZorbs can also be used in series or parallel to increase the peak power ratings.

TransZorbs have proven to be effective in Airborne Avionics and Controls, Mobil Communication Equipment, Computer Power Supplies, Numerically Controlled Machinery, and in many other applications where inductive and switching transients are present.

- 1500 watts peak power dissipation
- Available in ranges from 6.8V to 110V.

#### MAXIMUM RATINGS

- 1500 Watts of Peak Pulse Power dissipation at 25°C
- $t_{\text{clamping}}$  (0 volts to 8V min): Less than  $1 \times 10^{-12}$  seconds
- Operating and Storage Temperatures: -65° to +175°C
- Forward surge rating: 200 amps, 1/120 second at 25°C
- Steady State power dissipation: 1.0 W
- Repetition rate (duty cycle): .01%

#### MECHANICAL CHARACTERISTICS

- Ceramic Case with Metal Caps
- Weight: 1.25 grams (approximate)
- Polarity marked with polarity symbol
- Body marked with Logo and type number

#### ELECTRICAL CHARACTERISTICS

- Clamping Ratio: 1.33 @ Full rated power  
1.15 @ 50% rated power

Clamping Ratio: The ratio of the actual  $V_C$  (Clamping Voltage) to the actual  $BV$  (Breakdown Voltage) as measured on a specific device (See figure 3 for test pulse wave shape)

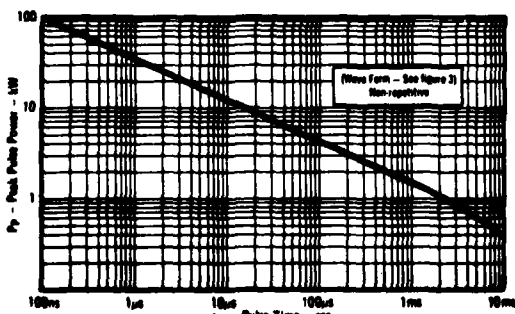

FIGURE 1 - Peak Pulse Power vs Pulse Time

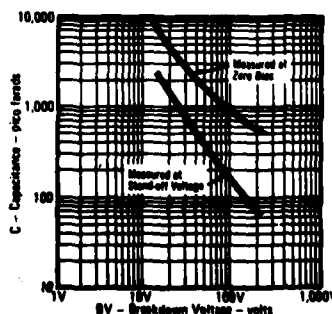
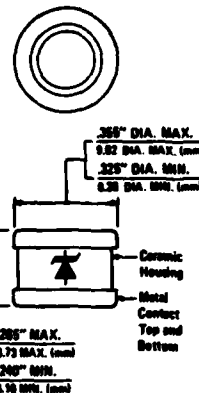

FIGURE 2 - Typical Capacitance vs Breakdown Voltage



(Shown 2 Times Actual Size)



(Shown 2 Times Actual Size)

#### ABBREVIATIONS & SYMBOLS

- $V_R$  Stand Off Voltage. Applied Reverse Voltage to assure a nonconductive condition. (See Note 1)
  - $BV(\text{min})$  This is the minimum Breakdown Voltage the device will exhibit and is used to assure that conduction does not occur prior to this voltage level at 25°C.
  - $V_C(\text{max})$  Maximum Clamping Voltage. The maximum peak voltage appearing across the TransZorb when subjected to the peak pulse current in a one millisecond time interval. The peak pulse voltages are the combination of voltage rise due to both the series resistance and thermal rise.
  - $I_{pp}$  Peak Pulse Current - See Figure 3
  - $P_p$  Peak Pulse Power
  - $I_R$  Reverse Leakage
- Note 1:  
A TransZorb is normally selected according to the reverse "Stand Off Voltage" ( $V_R$ ) which should be equal to or greater than the DC or continuous peak operating voltage level

# GENERAL SEMICONDUCTOR INDUSTRIES, INC.

## ELECTRICAL CHARACTERISTICS at 25°C

GENERAL SEMICONDUCTOR PART NUMBER	REVERSE STAND-OFF VOLTAGE (See Note 1) $V_R$ VOLTS	BREAKDOWN VOLTAGE $V_B$ VOLTS		h mA	MAXIMUM CLAMPING VOLTAGE $V_C$ (See Fig. 3) VOLTS	MAXIMUM REVERSE LEAKAGE CURRENT $I_R$ $\mu$ A	MAXIMUM PEAK PULSE CURRENT (See Fig. 3) A	MAXIMUM TEMPERATURE COEFFICIENT OF BV %/°C
		Min.	Max.					
1.5KC5.8	5.50	6.12	7.48	10	10.8	1000	139	.057
1.5KC5.8A	5.80	6.45	7.14	10	10.5	1000	143	.057
1.5KC7.5	6.05	6.75	8.25	10	11.7	500	128	.061
1.5KC7.5A	6.40	7.13	7.88	10	11.3	500	132	.061
1.5KC8.2	6.63	7.38	9.02	10	12.5	200	120	.065
1.5KC8.2A	7.02	7.79	8.61	10	12.1	200	124	.065
1.5KC9.1	7.37	8.19	10.0	1	13.8	50	109	.068
1.5KC9.1A	7.78	8.65	9.55	1	13.4	50	112	.068
1.5KC10	8.10	9.00	11.0	1	15.0	10	100	.073
1.5KC10A	8.55	9.5	10.5	1	14.5	10	103	.073
1.5KC11	8.92	9.9	12.1	1	16.2	5	93	.075
1.5KC11A	9.40	10.5	11.6	1	15.6	5	96	.075
1.5KC12	9.72	10.8	13.2	1	17.3	5	87	.078
1.5KC12A	10.2	11.4	12.6	1	16.7	5	90	.078
1.5KC13	10.5	11.7	14.3	1	19.0	5	79	.081
1.5KC13A	11.1	12.4	13.7	1	18.2	5	82	.081
1.5KC15	12.1	13.5	16.5	1	22.0	5	68	.084
1.5KC15A	12.8	14.3	15.8	1	21.2	5	71	.084
1.5KC16	12.9	14.4	17.6	1	23.5	5	64	.086
1.5KC16A	13.6	15.2	16.8	1	22.5	5	67	.086
1.5KC18	14.5	16.2	19.8	1	26.5	5	56.5	.088
1.5KC18A	15.3	17.1	18.9	1	25.2	5	59.5	.088
1.5KC20	16.2	18.0	22.0	1	29.1	5	51.5	.090
1.5KC20A	17.1	19.0	21.0	1	27.7	5	54	.090
1.5KC22	17.8	19.8	24.2	1	31.9	5	47	.092
1.5KC22A	18.8	20.9	23.1	1	30.6	5	49	.092
1.5KC24	19.4	21.6	26.4	1	34.7	5	43	.094
1.5KC24A	20.5	22.8	25.2	1	33.2	5	45	.094
1.5KC27	21.8	24.3	29.7	1	39.1	5	38.5	.096
1.5KC27A	23.1	25.7	28.4	1	37.5	5	40	.096
1.5KC30	24.3	27.0	33.0	1	43.5	5	34.5	.097
1.5KC30A	25.6	28.5	31.5	1	41.4	5	36	.097
1.5KC33	26.8	29.7	36.3	1	47.7	5	31.5	.098
1.5KC33A	28.2	31.4	34.7	1	45.7	5	33	.098
1.5KC36	29.1	32.4	39.6	1	52.0	5	29	.099
1.5KC36A	30.8	34.2	37.8	1	49.9	5	30	.099
1.5KC39	31.6	35.1	42.9	1	56.4	5	26.5	.100
1.5KC39A	33.3	37.1	41.0	1	53.9	5	28	.100
1.5KC43	34.8	38.7	47.3	1	61.9	5	24	.101
1.5KC43A	36.8	40.9	45.2	1	59.3	5	25.3	.101
1.5KC47	38.1	42.3	51.7	1	67.8	5	22.2	.101
1.5KC47A	40.2	44.7	49.4	1	64.8	5	23.2	.101
1.5KC51	41.3	45.9	56.1	1	73.5	5	20.4	.102
1.5KC51A	43.6	48.5	53.6	1	70.1	5	21.4	.102
1.5KC56	45.4	50.4	61.6	1	80.5	5	18.6	.103
1.5KC56A	47.8	53.2	58.8	1	77.0	5	19.5	.103
1.5KC62	50.2	55.8	68.2	1	89.0	5	16.9	.104
1.5KC62A	53.0	58.9	65.1	1	85.0	5	17.7	.104
1.5KC68	55.1	61.2	74.8	1	98.0	5	15.3	.104
1.5KC68A	58.1	64.6	71.4	1	92.0	5	16.3	.104
1.5KC75	60.7	67.5	82.5	1	108.0	5	13.9	.105
1.5KC75A	64.1	71.3	78.8	1	103.0	5	14.6	.105
1.5KC82	66.4	73.8	90.2	1	118.0	5	12.7	.105
1.5KC82A	70.1	77.9	86.1	1	113.0	5	13.3	.105
1.5KC91	73.7	81.9	100.0	1	131.0	5	11.4	.106
1.5KC91A	77.8	86.5	95.5	1	125.0	5	12.0	.106
1.5KC100	81.0	90.0	110.0	1	144.0	5	10.4	.106
1.5KC100A	85.5	95.0	105.0	1	137.0	5	11.0	.106
1.5KC110	89.2	99.0	121.0	1	158.0	5	9.5	.107
1.5KC110A	94.0	105.0	116.0	1	152.0	5	9.9	.107

$V_R$  at 100 AMPS PEAK, 0.3 MSEC SINE WAVE equals 3.0 VOLTS MAXIMUM

Transistors™ can be used in series or parallel to increase their power handling capability. No precautions are required when using Transistors™ in a series string and power dissipation for two or more devices of the same type is evenly shared. When using Transistors™ in parallel it is necessary for the units to be closely matched (approx. 1 volt of each other) in order for equal sharing to take place. Matched sets can be ordered from the factory for a small additional charge.

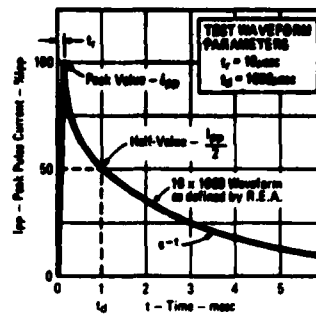

FIGURE 3 - Pulse Wave Form

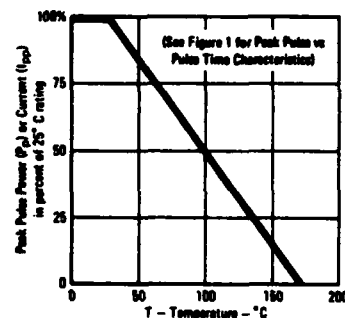

FIGURE 4 - Derating Curve

Non-standard voltage types between those tabulated may be specified as illustrated:

Family Type	Nominal BV	Tolerance	Suffix
1.5KC	7.2	A	

- BV Will be Nominal BV  $\pm 5\%$  for "A" suffix types and  $\pm 10\%$  for non-suffix types at the test current of the next lower standard voltage type.
- $V_R$  Will be 85% of Nominal BV for "A" suffix type and 81% of Nominal BV for non-suffix types.
- $V_C$  Will be proportionately interpolated between the two neighboring standard types.
- $I_R$  Will be that of the next lower standard type.
- $I_{RT}$  Will be proportionately interpolated between the two neighboring standard types.

### BIPOLAR APPLICATIONS

For Bipolar use C or CA Suffix for types 1.5KC7.5 through types 1.5KC110. Electrical characteristics apply in both directions.

BREAKDOWN VOLTAGE: BV @ 1 mA 34.2V Min. 37.8V Max.

REVERSE LEAKAGE CURRENT:  $I_R$  @ 31 V: 5 $\mu$ A Max.

CLAMPING VOLTAGE @ 30A  $I_{pp}$ : 55V Max.

MAXIMUM PEAK PULSE CURRENT  $I_{pp}$ : 30A, 10 x 1000  $\mu$ sec waveform

CAPACITANCE @ 0v Bias: 200 pf Max.

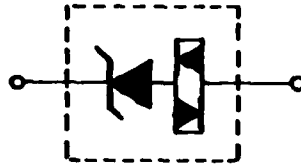

1 TransZorb Cell

2 Varistor Cells

 GENERAL SEMICONDUCTOR INDUSTRIES, INC. 800 WEST TENTH PLACE - TEMPE, ARIZONA 85281	DRAWN BY J.J. Pizzicstoli	
	APPROVED	
	REV. $\phi$	DATE 14 JUN 79
CUSTOMER: FLORIDA INSTITUTE OF TECHNOLOGY		
CUSTOMER PART NO:		
GSI PART NO: GZ92111A		

BREAKDOWN VOLTAGE: 1 mA, 48.5V Min. 53.6V Max.

REVERSE LEAKAGE CURRENT:  $I_R @ 44V$ : 5  $\mu A$  Max.

CLAMPING VOLTAGE @ 21A  $I_{pp}$ : 75V Max.

MAXIMUM PEAK PULSE CURRENT  $I_{pp}$ : 21A, 10 x 1000  $\mu sec$  waveform

CAPACITANCE @ Ov Bias: 200 pf Max.

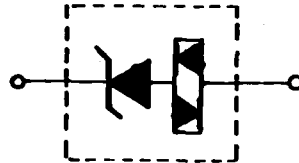

1 Transzorb Cell

2 Varistor Cells

 GENERAL SEMICONDUCTOR INDUSTRIES, INC. 2001 WEST TENTH PLACE • TEMPE, ARIZONA 85281	DRAWN BY J.J. Pizzicardi	
	APPROVED	
	REV. $\beta$	DATE 14 Jun 79
CUSTOMER: FLORIDA INSTITUTE OF TECHNOLOGY		
CUSTOMER PART NO:		
GSI PART NO: G292111B		

**ELECTRICAL CHARACTERISTICS:**

**Breakdown Voltage:** BV @ 10mA: 6.66V min., 8.14V max.

**Reverse Leakage Current:** Ir @ 5.0V: 1500µA max.

**Clamping Voltage @ 70A Ipp:** 12V max.

**Maximum Peak Pulse Current Ipp:**  
70A down to 1/4 crest value in 1msec.

**Capacitance @ 0V Bias:** 250pf max.

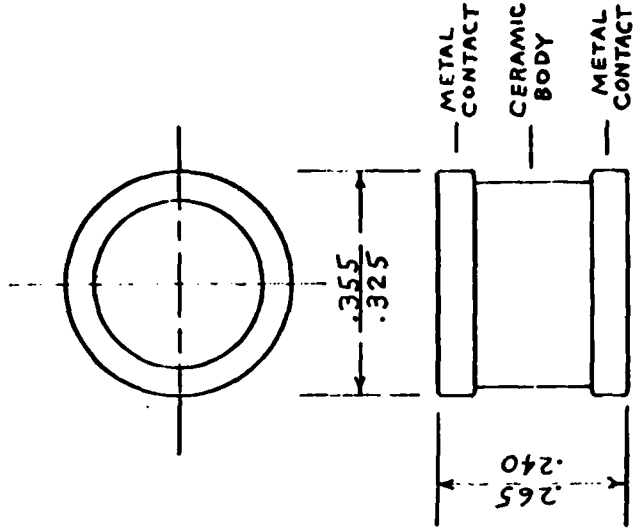

<p>GENERAL SEMICONDUCTOR INDUSTRIES INC 200 WEST TENTH PLACE - TALLAHASSEE, FLORIDA 32301</p>	DRAWN BY J PIZZICAROLI	
	APPROVED	
	REV. 0	DATE 5-27-77
CUSTOMER: FLORIDA INSTITUTE OF TECHNOLOGY / FAA		
CUSTOMER PART NO:		
GSI PART NO: GZ60316B		