

AD-A091 672

CIVIL ENGINEERING LAB (NAVY) PORT HUENEME CA
SAFE UNDERWATER ELECTRICAL POWER.(U)
FEB 80 L W TUCKER, F E NELSON
CEL-TN-1569

F/6 9/3

UNCLASSIFIED

NL

1 of 1
AD-A
Catalog

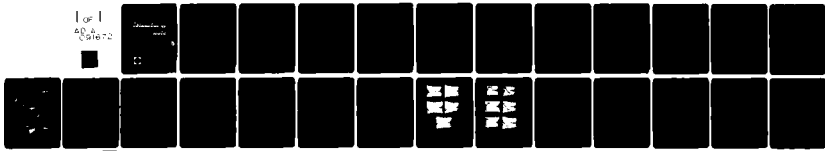

END
DATE
FILMED
12-80
DTIC

LEVEL II

2
A

AD A091672

Technical



Note

TN no. N-1569

title: SAFE UNDERWATER ELECTRICAL POWER

author: L. W. Tucker and F. E. Nelson

date: February 1980

sponsor: Naval Facilities Engineering Command

program nos: YF59.556.091.01.306

DTIC
SELECTED
NOV 14 1980
D
C

DDC FILE COPY



CIVIL ENGINEERING LABORATORY

NAVAL CONSTRUCTION BATTALION CENTER
Port Hueneme, California 93043

Approved for public release; distribution unlimited.

80 11 10 043

Unclassified

SECURITY CLASSIFICATION OF THIS PAGE (When Data Entered)

REPORT DOCUMENTATION PAGE		READ INSTRUCTIONS BEFORE COMPLETING FORM
1. REPORT NUMBER TN-1569	2. GOVT ACCESSION NO. DN787013	3. RECIPIENT'S CATALOG NUMBER AD-AC91672
4. TITLE (and Subtitle) SAFE UNDERWATER ELECTRICAL POWER		5. TYPE OF REPORT & PERIOD COVERED Not final; Oct 78 - Sep 79
7. AUTHOR(s) L. W. Tucker R. E. Nelson		6. PERFORMING ORG. REPORT NUMBER
9. PERFORMING ORGANIZATION NAME AND ADDRESS CIVIL ENGINEERING LABORATORY Naval Construction Battalion Center Port Huene, California 93043		8. CONTRACT OR GRANT NUMBER(s) 12-511
11. CONTROLLING OFFICE NAME AND ADDRESS Naval Facilities Engineering Command Alexandria, Virginia 22332		10. PROGRAM ELEMENT, PROJECT, TASK AREA & WORK UNIT NUMBERS YF5955609101.306
14. MONITORING AGENCY NAME & ADDRESS (if different from Controlling Office) 16-15561		12. REPORT DATE February 1980
		13. NUMBER OF PAGES 23
		15. SECURITY CLASS. (of this report) Unclassified
16. DISTRIBUTION STATEMENT (of this Report) Approved for public release; distribution unlimited.		15a. DECLASSIFICATION/DOWNGRADING SCHEDULE
17. DISTRIBUTION STATEMENT (of the abstract entered in Block 20, if different from Report)		
18. SUPPLEMENTARY NOTES		
19. KEY WORDS (Continue on reverse side if necessary and identify by block number) Electrical safety, power transmission, ground fault detector, diver safety.		
20. ABSTRACT (Continue on reverse side if necessary and identify by block number) The Civil Engineering Laboratory is developing a unique and improved ground fault detection and diver protection system that will allow safe electrical power transmission underwater. The system is designed to sense and shut down all electrical power on ground fault currents of 4.5 mA or more in 10 ms. The shutdown is performed in two steps: (1) first a signal initiated by a leakage to ground in the transmission cable or load trips the main power circuit breaker, and (2) a set of triacs are turned on which are connected to		

DD FORM 1 JAN 73 1473 EDITION OF 1 NOV 65 IS OBSOLETE

(continued)

Unclassified
SECURITY CLASSIFICATION OF THIS PAGE (When Data Entered)

311 111

310

Unclassified

SECURITY CLASSIFICATION OF THIS PAGE (When Data Entered)

20. Continued

short the power lines. The circuit breaker is backed up by conventional fuses that would blow quickly from the short circuit current if the breaker should fail. This sequence of events is designed to occur in approximately 10 ms. The design of the system is adaptable to electric power transmission systems supplying up to 100 kW.

The paper reviews electrical safety criteria relative to divers, describes the Civil Engineering Laboratory's protection concept, and presents laboratory test results from an experimental system protection a 30-kW underwater load.

Library Card

Civil Engineering Laboratory
SAFE UNDERWATER ELECTRICAL POWER
by L. W. Tucker and F. E. Nelson
TN-1569 23 pp illus February 1980 Unclassified

1. Electrical safety 2. Power transmission I. YF59.556.091.01.306

The Civil Engineering Laboratory is developing a unique and improved ground fault detection and diver protection system that will allow safe electrical power transmission underwater. The system is designed to sense and shut down all electrical power on ground fault currents of 4.5 mA or more in 10 ms. The shutdown is performed in two steps: (1) first a signal initiated by a leakage to ground in the transmission cable or load trips the main power circuit breaker, and (2) a set of triacs are turned on which are connected to short the power lines. The circuit breaker is backed up by conventional fuses that would blow quickly from the short circuit current if the breaker should fail. This sequence of events is designed to occur in approximately 10 ms. The design of the system is adaptable to electric power transmission systems supplying up to 100 kW.

The paper reviews electrical safety criteria relative to divers, describes the Civil Engineering Laboratory's protection concept, and presents laboratory test results from an experimental system protecting a 30-kW underwater load.

Unclassified

SECURITY CLASSIFICATION OF THIS PAGE (When Data Entered)

CONTENTS

	Page
INTRODUCTION	1
BACKGROUND	1
ERA PROTECTION CONCEPTS	2
Inherently Safe Electrical Power	2
Earth-Leakage Circuit Breaker	2
ERA Fail-Safe Method of Protection	4
DEVELOPMENT OF CEL FAIL-SAFE PROTECTION SYSTEM	5
DC Ground Resistance Monitor	10
AC Circuit Monitor	10
Triac Control Circuit	10
TEST RESULTS	13
Trip Level Adjustment of Circuit Breaker	13
Resistive Load Tests	13
Inductive Load Tests	15
SUMMARY	15
CONCLUSIONS	18
PLANS	18
REFERENCES	18

Accession For	
NTIS GR&I	<input checked="" type="checkbox"/>
DTIC TAB	<input type="checkbox"/>
Unannounced	<input type="checkbox"/>
Justification	<input type="checkbox"/>
By _____	
Distribution/	
Availability Codes	
Dist	Special
A	

INTRODUCTION

The use of electricity underwater requires a new class of electrical protection equipment to meet the stringent safety criteria needed to protect working divers. To meet these requirements the Civil Engineering Laboratory (CEL) under the sponsorship of the Naval Facilities Engineering Command, Ocean Facilities Exploratory Development Block Program has developed a unique and improved ground fault detection and power shutdown system.

The system is designed to shut down all electrical power to the load in 10 ms upon sensing a ground fault current. The design of the system is adaptable to electric power transmission systems up to 100 kW of AC power.

This report reviews electrical safety criteria relative to divers and describes CEL's ground fault detection and protection concept. Laboratory test results from a breadboard model of the system are also presented.

BACKGROUND

Electricity can be used safely underwater provided the diver is protected from shock hazards. Safe current/time relationships are summarized in the International Electrochemical Commission's (IEC) report "The Effects of Current Passing Through the Human Body" (Ref 1) and are shown in Figure 1. The IEC data have been used only for design objectives. Neither CEL nor the U.S. Navy endorses or accepts the IEC data as providing safe operating levels for divers using underwater electric equipment. The U.S. Navy is currently reviewing criteria for safe use of electricity underwater, but at the time of this writing, no firm criteria for U.S. Navy usage have been established. A diver protection system must either limit the fault current to the "let-go-level" or interrupt the fault current quickly. The "let-go-current" is defined by the IEC as "the maximum current a person can tolerate when holding an electrode and still let go of this electrode using muscles directly stimulated by that current."

The application of electric power underwater involves hazards to people not present in overland uses. Of primary importance is the reduction in skin contact resistance caused by water absorption. The nominal dry skin contact resistance of 3500 ohms may drop to 250 ohms in seawater. This decrease in skin resistance reduces the voltage gradient required to create a fatal current flow through the body. This voltage can be applied to the diver directly by physical contact or by the presence of a strong electric field. In either case it is important to provide protection circuits that exceed the requirements of overland use.

In 1971 the British established the Underwater Electrical Safety Project with the objective of determining methods with which divers could be protected from electrical shock hazards. This work is summarized by Dr. G. Mole of the Electrical Research Association (ERA) in his report "The Safer Use of Electrical Equipment Underwater - Guidance

for Methods of Protection" (Ref 2). Three basic concepts for protection are discussed:

1. Inherently safe underwater power systems
2. Earth (ground) leakage circuit breakers
3. Fail-safe circuit protection

ERA PROTECTION CONCEPTS

Inherently Safe Electrical Power

An inherently safe electric power supply is defined as a system which "is incapable of delivering a lethal electrical shock under all adverse conditions, such as leakage and fault" (Ref 3). The design of the inherently safe system can be based on current-limiting or voltage-limiting principles. In the current-limiting approach, power is supplied at a constant current equal to the let-go-level. With voltage limitation, the voltage supplied divided by the diver's body resistance must not exceed the let-go-level.

A current-limited DC system was built and tested by the ERA. DC voltage was chosen for the first system because of the higher let-go-current level, i.e., 62 mA DC versus 9 mA AC. A block diagram of the system is given in Figure 2. The 62-mA constant-current supply is derived from the ship's power system via a constant-voltage/constant-current converter and is fed to an inverter on the seafloor through the transmission cable at ± 25 kVDC. The output of the seafloor inverter is 30 VDC at currents up to 70 amperes, depending upon equipment requirements. Even with transmission voltages of 25 kVDC in the system, fatal shock is not possible because the current is limited to the maximum safe level for DC. With a minimum body resistance, hand-to-hand, of 500 ohms, the 30-VDC potential limits the maximum current through the hands and chest to less than 62 mA. This 2.5-kW system represents a realistic size to which future inherently safe power supply designs can be compared. A detailed description of the design of the individual components is contained in Reference 4 by Mole and Parr.

From a technical standpoint the proposed power system concept is valid. The design study shows that a DC inherently safe power supply would be substantially more complex than originally thought, but feasible. The complexity results in both higher construction cost and possible maintenance problems. This design, however, does not prevent the diver from being shocked, but it does prevent the current level from exceeding the let-go-level of 62 mA. To prevent the diver from receiving a perceptible shock, a ground current leakage device must be used to shut down the system for leakage currents of less than 62 mA.

Earth-Leakage Circuit Breaker

A British survey of manufacturers identified 22 models of earth-leakage circuit breakers (ELCBs) on the world market (Ref 5). When installed on the supply circuit, these devices monitor the leakage current from the line conductor to ground. A typical circuit for one of the ELCBs is shown in Figure 3. For the configuration shown, the current

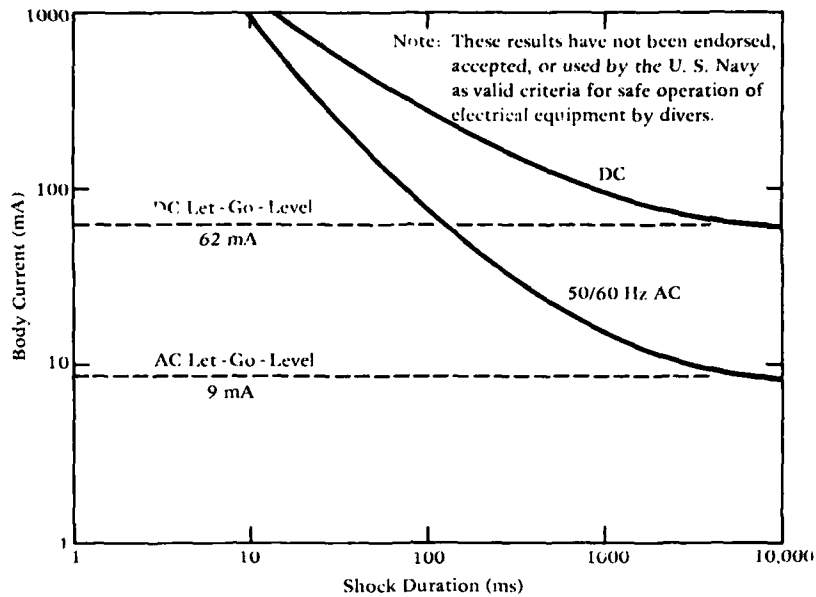

Figure 1. Usually* safe time/current characteristics (based on IEC Publication 479: Effects of current passing through the human body and is reproduced by permission of the International Electrotechnical Commission, which retains the copyright) (Ref 1).

*Applies to 99.9% of male population weighing more than 50 kg; values for women are approximately 2/3 of those for men.

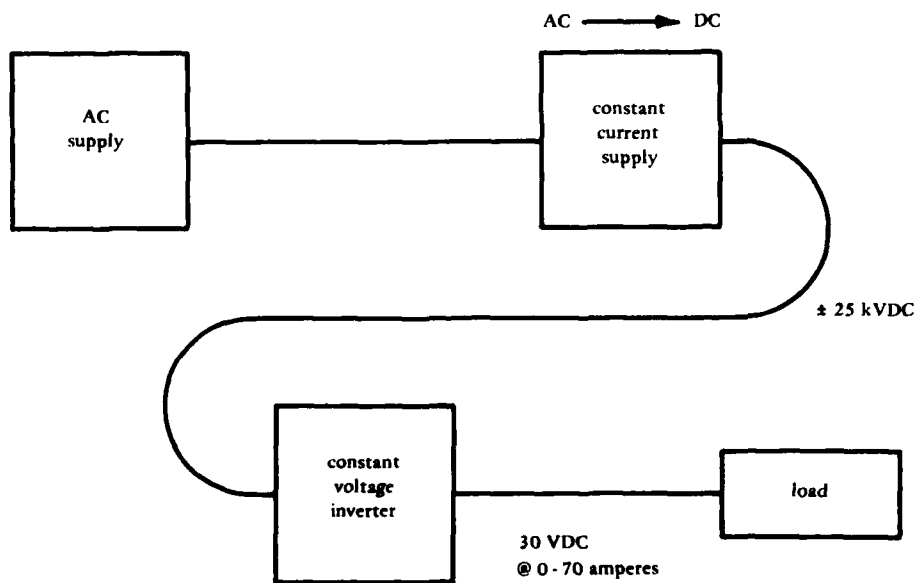

Figure 2. Inherently safe power supply concept.

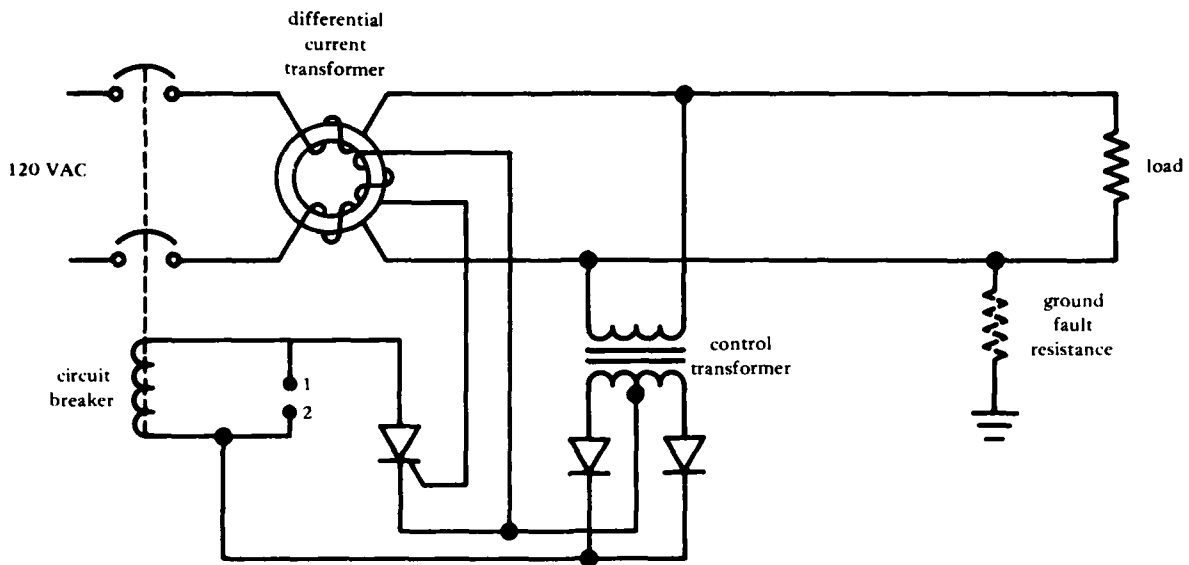

Figure 3. Earth leakage circuit breaker, solid-state-assisted type.

in the line side must equal the current returned in the neutral. If the currents are not equal, a voltage is induced into the control circuit and the circuit, breaker trips, turning off the supply voltage.

Results of the British circuit breaker evaluation show that it is possible to buy off-the-shelf ELCBs that can shut down on as little as 2.5 mA of leakage current in less than 25 ms. Circuit breakers of this type and sensitivity, however, may be subject to nuisance tripping and, thus, not be practical for field use.

ERA Fail-Safe Method of Protection

The need for quicker acting, less nuisance tripping and higher power capabilities in the diver protection systems led to the development of the fail-safe concept. This concept allows the load current to be supplied from any available AC source with the protection system connected in series between the supply and load. One possible configuration is shown in Figure 4. The sensitivity of the control circuit and the speed of the solid state switches (triacs) combine to provide a fail-safe system.

During operation the load is connected to the supply via an isolating transformer that has a center-tapped secondary. A DC voltage is applied to the power circuit at the center tap. Any current leakage to ground also flows through the resistor R, and the voltage drop (VR) is monitored by the control unit. If VR exceeds a preset level, the control unit

turns on the solid state triacs, which rapidly short out the primary voltage source. The short circuit current then trips the electro-mechanical circuit breaker. This type of protection allows power from shipboard or commercial mains to be used safely underwater.

The circuit as shown in Figure 4 is capable of shorting the transmission lines in less than 10 ms, followed quickly by a circuit breaker trip. The fuse opens the circuit only in case of a circuit breaker failure. The design of the entire safety system is based on fail-safe criteria. This means the system is designed to shut down all power to the load upon detecting either a ground fault or a failure of a component in the detection system. A complete discussion of the design is contained in Reference 6.

This design offers a high degree of protection to divers using equipment powered from conventional AC sources. Furthermore, this protection concept is not power-limited as is the inherently safe approach. It also provides a faster response capability as compared to ELCBs and reduces nuisance tripping. Nuisance tripping is caused by changes in distributed capacitance in long cables. Monitoring for DC leakage currents eliminates the capacitance effects. The design allows off-the-shelf power conditioning and transmission hardware to be used, thus making the concept very attractive.

The reliability and speed of the solid state triacs in shorting out the supply source provide excellent protection for the diver. However, the triacs must be protected from extended periods of short circuit current flow. Some design improvements are, therefore, necessary to decrease circuit breaker trip time to properly protect the triacs.

DEVELOPMENT OF CEL FAIL-SAFE PROTECTION SYSTEM

The ERA fail-safe protection system and the CEL system are both insulation resistance monitoring devices. They are designed to fail to a safe condition by shutting down electrical power to the load. The failure may be a break detected in the electrical insulation of the protected circuit or a malfunction of the electronics within the device. Figure 5 shows a block diagram of the CEL concept. The only difference between the ERA and CEL design revealed by a comparison of Figures 4 and 5 is the relocation of the triacs from the supply side of the transformer to the load side. There are, however, major differences in the operational sequence. These significant differences will be discussed as the CEL concept is described.

As shown in Figure 5, the load is electrically isolated from the supply and ground by the wye-delta transformer. One side of a DC voltage supply is connected to a corner of the delta winding. The other side of the supply is connected to ground (seawater). Should the electrical insulation of the protected circuit break down, a small DC leakage current would flow. It is this leakage current that is monitored. If this current level exceeds a predetermined level, a set of solid state switches (triacs) are turned on by the ground fault detector (GFD). At the same time the GFD sends a trip signal to the circuit breaker. The triacs short the secondary of the transformer, reducing the load voltage to zero but creating very high short circuit currents in the circuit breaker and triacs. The circuit breaker then rapidly opens, thus protecting the triacs from damage.

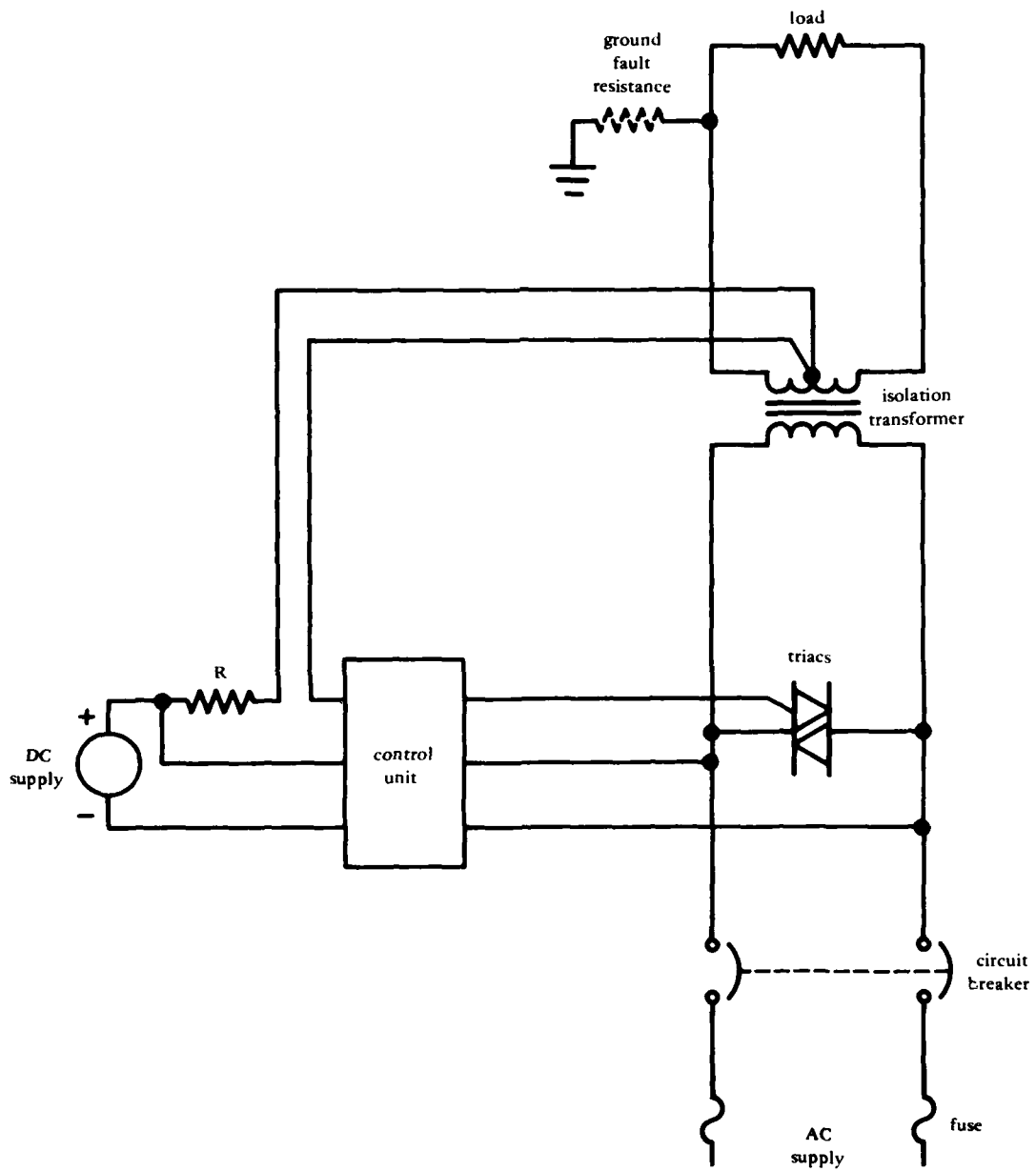

Figure 4. Basic schematic for the ERA fail-safe protection system.

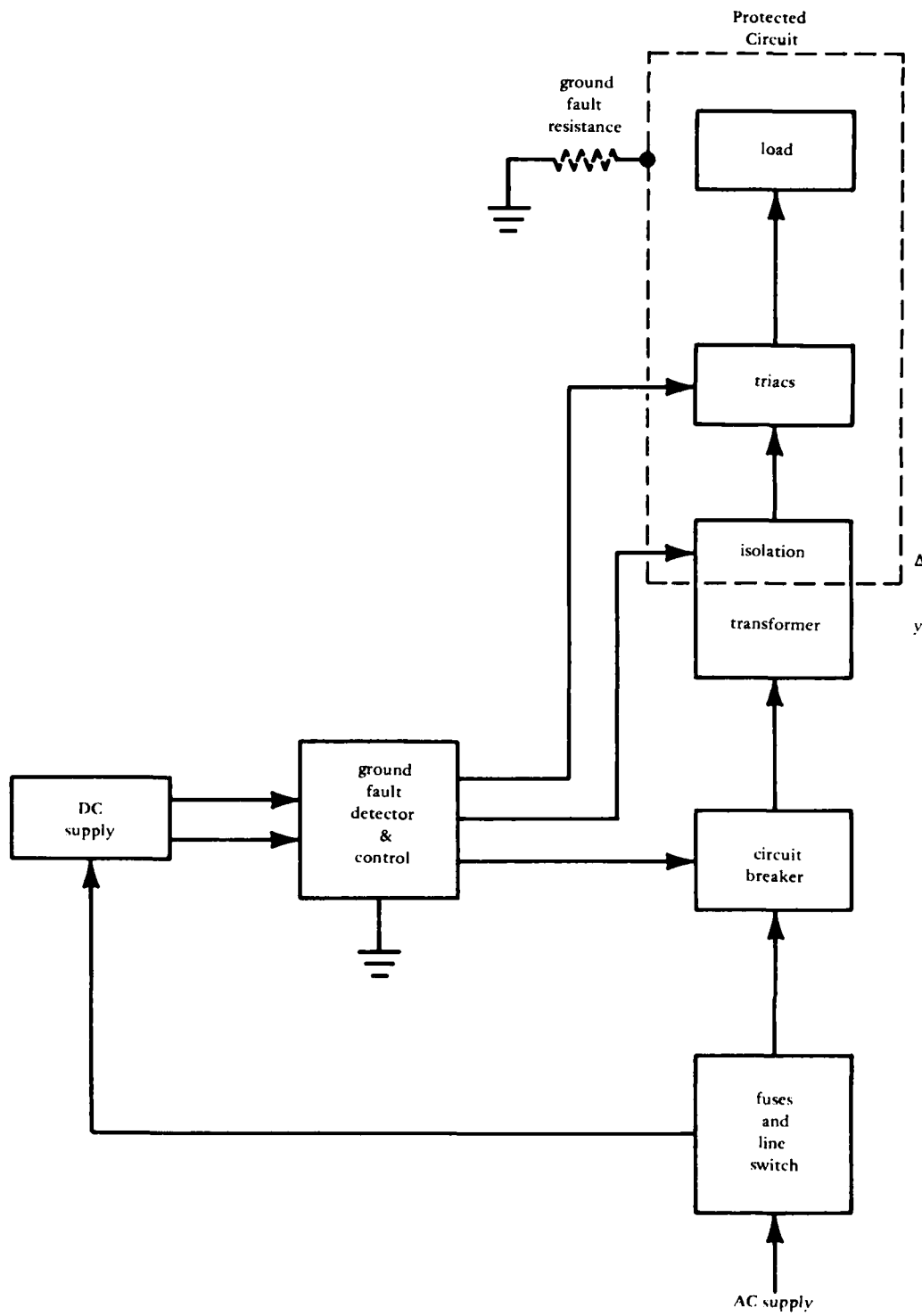

Figure 5. Block diagram of the CEL ground fault protection system concept.

Using this system as a starting point, ways to improve its operation were studied. Two areas were identified that could improve the operation and reliability of the system. First, the current that the triacs handle should be kept to a minimum. Normal rating practice for these devices specifies one cycle or 1/2 cycle surge current with higher currents allowed for shorter durations. Since the typical circuit breaker requires 25 ms to open, the triacs could see up to 1-1/2 cycles (60 Hz) of surge current. To handle this current, a device with a higher current rating has to be used. This results in increased cost and size requirements for the triacs. The high currents also cause severe arcing of the circuit breaker contacts. This reduces the life and reliability of the breaker.

One way to solve both of these problems would be to decrease the time required to open the circuit breaker. Ground fault circuit breakers from several different manufacturers were purchased for testing. The purpose of these tests was to determine how the tripping mechanism worked and how fast it opened a circuit upon detecting its minimum-rated ground fault current. Using Figure 3 as an example, the ground fault signal required to trip the breaker was measured between terminals 1 and 2. The circuit breakers were then subjected to a step input signal of the measured magnitude at the input to their ground fault detection circuit. The time from application of this signal until the power contacts opened was measured. The breakers were subjected to this several times, while the action of the trip mechanisms was observed.

The 5SV series of circuit breakers built by the Siemens Corporation, Iselen, N.J., was picked as best suited for modification to meet the CEL system's requirements. This breaker uses the transformer input to the trip mechanism as shown in Figure 4, but has no built-in solid state electronics. The breaker is held in the set position by a small bar that completes the magnetic circuit of a horseshoe magnet. The breaker exhibited a repeatable opening time of 20 to 26 ms, and the tripping circuit and mechanical components were accessible for possible modifications.

As shown in Figure 6 one pole of the horseshoe magnet has a coil wound around it; this coil is normally hooked to the secondary of the ground fault detection transformer. A ground fault current creates an unbalanced current flow in the power leads that form the primary winding of the transformer. This unbalanced current generates a magnetic flux in the core and induces a voltage in the transformer secondary and the trip coil on the pole piece. When the leakage current is sufficient to form an electromagnet in the coil with poles opposite to the natural magnet, the shorting bar is released, tripping the circuit breaker. The input to the trip coil is an AC voltage that allows the electromagnet to have the correct polarity to trip every other half cycle. This results in trip times of up to 1 cycle (16.62 ms) plus the time required for the contacts to open.

A Siemens circuit breaker, model 5SV4071, rated at 63 amperes, was modified by: (1) removing the fault transformer core and reconnecting the power leads; (2) removing the existing coil on the magnet and replacing it with a new coil having more turns of smaller wire; and (3) adjusting the trip mechanism spring tension to a point slightly beyond where the permanent magnet will latch the breaker in the set position. When DC instead of AC is applied to the coil, an electromagnet is formed, aiding



Figure 6. Siemens 5SV2 071 Ground Fault Circuit Breaker.

the natural magnet in resetting the breaker. When the DC voltage is removed, the breaker will trip. This modification resulted in a trip time of 5.5 ± 0.2 ms.

Once it was established that fast, reliable operation could be obtained from the breaker, a system operational sequence, which overcomes the ERA fail-safe system shortcomings, was devised. Instead of turning on the triacs and the subsequent high current tripping the circuit breaker, it was decided to open the breaker first and then fire the triacs. With the circuit breaker open, not only could the high short circuit currents in the triacs be eliminated, but also the circuit breaker contacts would not be subjected to severe arcing while opening. The triacs shorting out the load circuit still provide a low impedance path to discharge the stored energy in the protected circuit. Should the circuit breaker fail to open upon receiving the trip signal, the triacs would still turn on after a 10-ms delay. The short circuit current would then blow the main line fuses to open the circuit.

DC Ground Resistance Monitor

The ground resistance is monitored using the circuit shown in Figure 7. The positive side of a 100-VDC supply is connected to the secondary of the power transformer through R1 and R2. The negative side of the supply is connected to ground. If a ground (RG) should develop in the protected circuit, a voltage would be generated across R2. This voltage is passed through the impedance matching amplifier at unity gain into the voltage comparator A2. When no ground exists, A2 is held in saturation with an output of 15 volts. If the voltage generated by the ground current in R2 exceeds a predetermined level set by R3, amplifier A2 changes state, and a trip signal is sent to the circuit breaker and triacs.

AC Circuit Monitor

The reliability of the ground resistance monitoring circuit depends upon maintaining a circuit for the ground fault current to flow in. The DC ground fault circuit is monitored using the schematic shown in Figure 8. A 10-kHz sine wave is superimposed on the 100 VDC being fed to the secondary of the transformer. Should the DC circuit open or the 10-kHz oscillator fail, amplifiers A3 and A4 would initiate a trip signal identical to the ground resistance monitor.

Triac Control Circuit

The triacs are used as solid state switches to short the power output to the load upon command. Figure 9 shows how they are connected in the circuit with their associated control circuitry. If the AC and DC monitors detect no faults, then the normally open switches S1 and S2 are closed. Depressing the momentary switch S6 energizes the electromagnet in the circuit breaker and opens S3, S4, and S5. When S3, S4, and S5 open, the triacs' gate voltage is removed, and the triacs open; at the same time, capacitor C1 charges to -30 VDC. With S6 still depressed, CBI is turned on. Once CBI is set, S6 is released.

A trip signal from either the ground resistance monitor or the AC circuit monitor removes the voltage to S1 or S2. This removes power

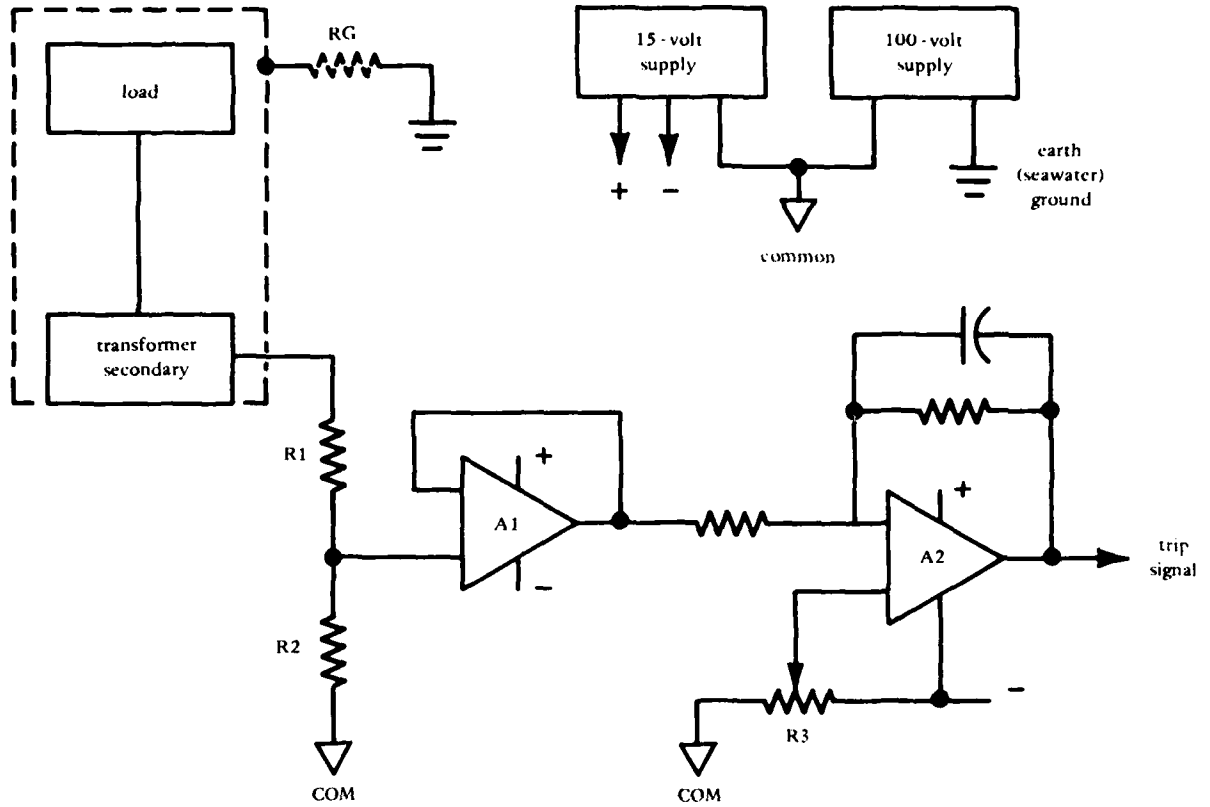

Figure 7. DC ground resistance (R_G) monitor (simplified schematic).

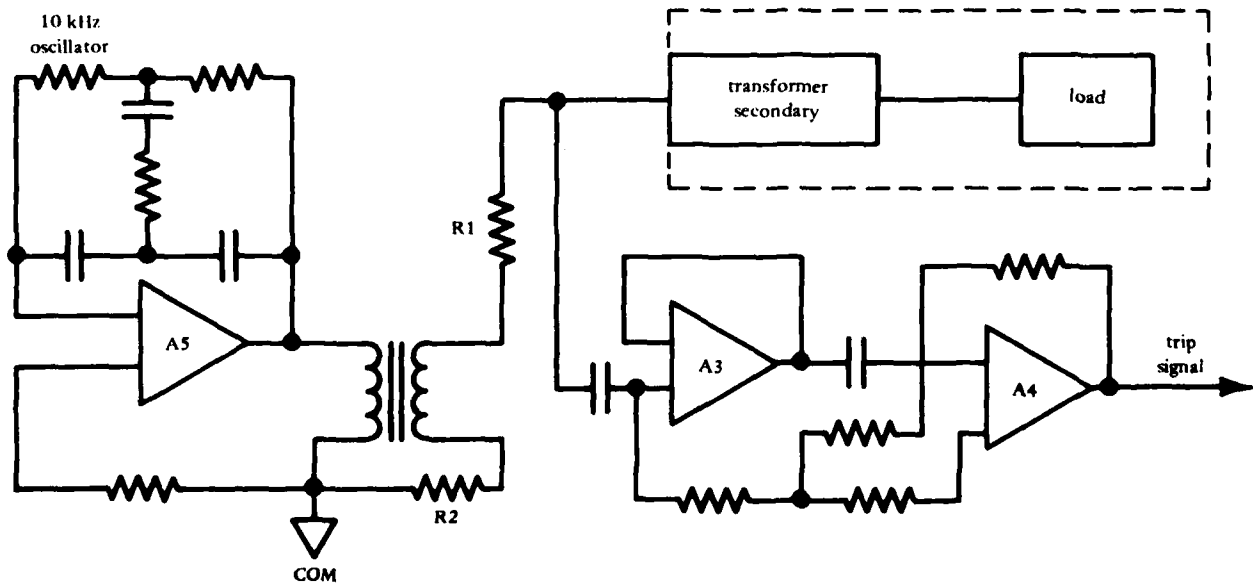

Figure 8. AC signal injection to monitor the integrity of the ground resistance detection circuit.

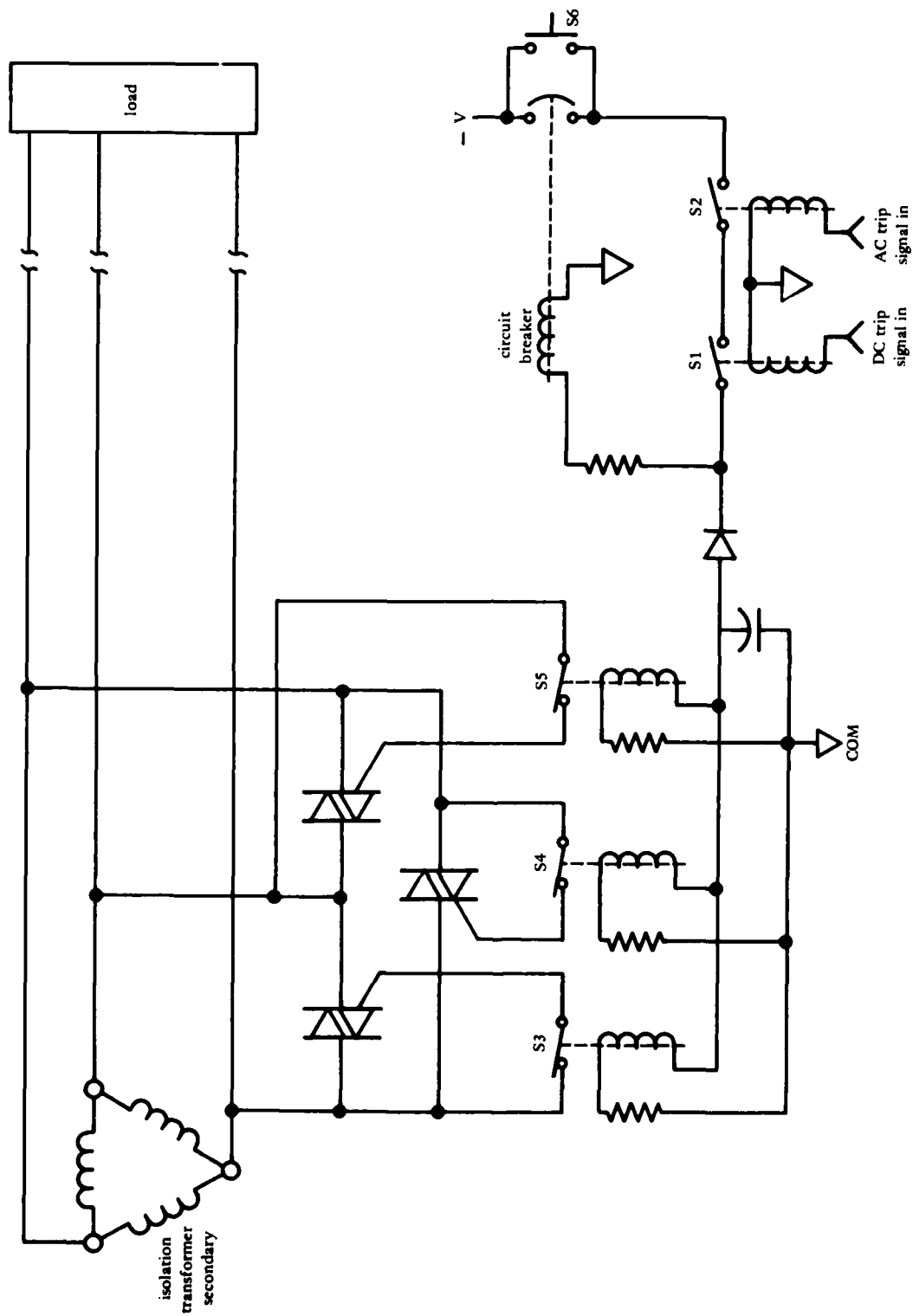

Figure 9. Schematic of triac control circuit.

from the trip coil, allowing the circuit breaker to open. Capacitor C1 is selected to prevent switches S3, S4, and S5 from closing for 10 ms. This allows time for the circuit breaker to open and any arc at the contacts to subside before the secondary circuit is short circuited. If CBI has not opened prior to the triacs being turned on, the short circuit current will blow the main power fuses. These fuses are selected to have an I^2t rating below the surge current rating of the triacs.

TEST RESULTS

Trip Level Adjustment of Circuit Breaker

The protection system was tested using 208-volt, 3-phase power supplied from the CEL utility system. A complete schematic of the protection system and line connections is presented in Figure 10. The circuit breaker shown is a Siemens ground fault circuit breaker, model 5SV4071 (modified), rated at 63 amperes. The early tests were conducted using twenty-one 1,000-watt (21 kW) strip heaters for a load.

The initial conditions for the first test were:

1. Circuit breaker set to trip in 5.5 ms
2. Triacs set for 5.5-ms delay
3. R3 adjusted to trip on 50 kilohms ground resistance (1.65 mA)

A decade resistance box was connected between one power lead and ground to simulate a fault. The precision resistors in the resistance box ($\pm 1\%$) allowed the ground resistance to be set at 0 to 10 megohms in 1-ohm increments. With the load disconnected, the circuit breaker trip point was adjusted by setting the decade box to 50K and turning R3 until a trip was achieved. The resistance was then increased to 52K and the circuit breaker reset. The resistance was switched out in 100-ohm steps until the breaker tripped. This was repeated until the breaker tripped reliably at 50K ± 500 ohms.

Resistive Load Tests

The 21-kW load bank was connected into the circuit (decade resistance set at 750K), and the power turned on. The ground resistance was reduced to 50K, and the breaker tripped. The primary and secondary line currents and voltages were recorded on an oscillograph recorder.

With the triacs firing at the same time, the circuit breaker opened with considerable arcing of the contacts. Current transients with a peak value of 270 amperes were recorded on the supply side of the transformer. At this time it was decided to delay the triacs turn-on for an additional 4.5 ms, resulting in a total delay of 10 ms. This decision was made based on the data presented in Figure 1. As shown, the no-danger DC current level for 10 ms is 1,000 mA. Since the ground resistance monitor circuit uses 100 VDC supplied through the voltage divider R1 and R2 having a total resistance of 100K, the leakage current is limited. Should a fault occur when a diver is in direct contact with the fault location, the maximum current to the diver would be 8.9 mA DC. This is well below the danger curve, and is, in fact, less than one-sixth the let-go-level for DC. The circuit was tested with the new delay time,

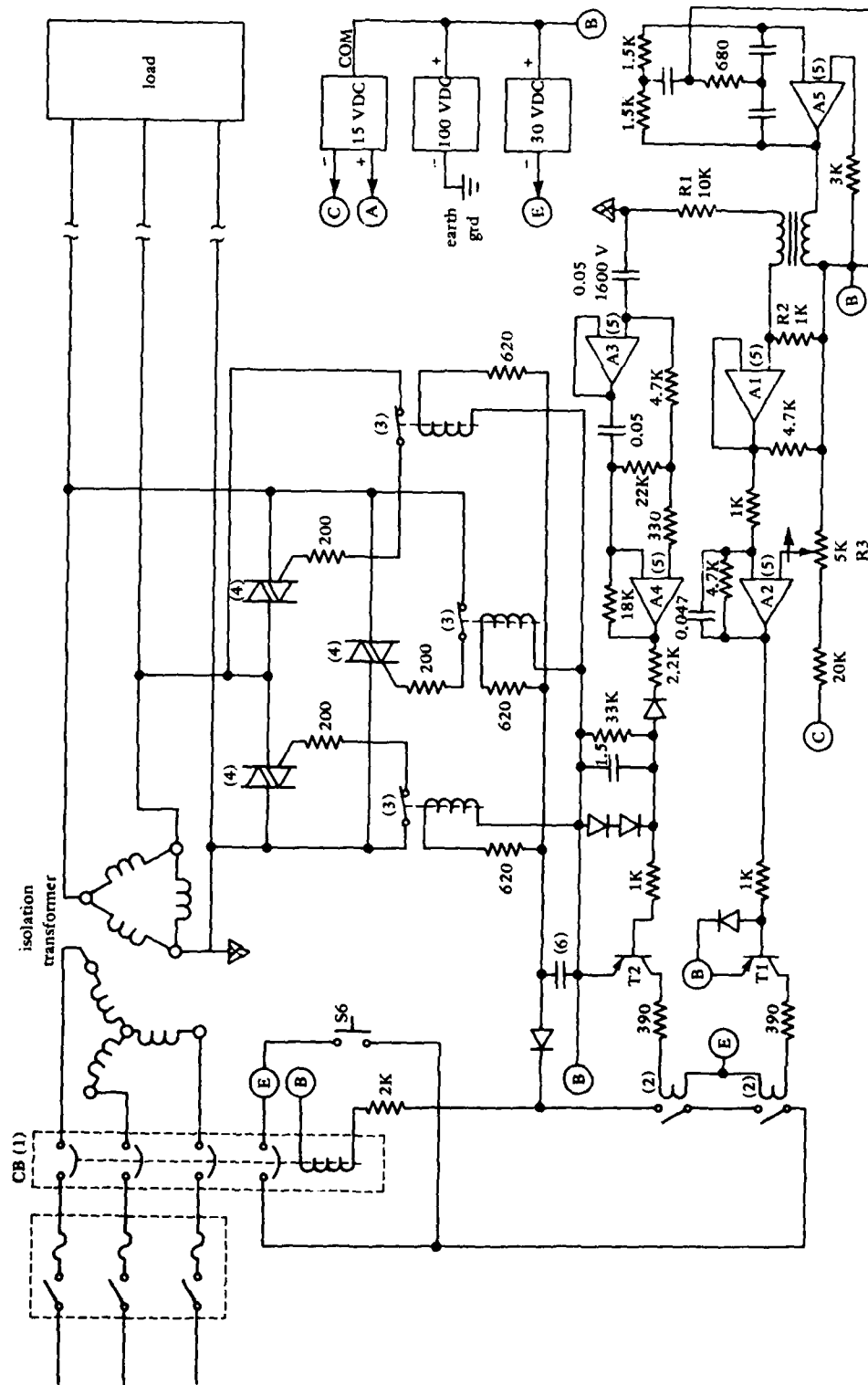

Figure 10. Schematic of CEL fail-safe system.

and the shutdown was completed with no current or voltage transients in a total shutdown time of 10 ms (circuit breaker opens in 5.5 ms and the triacs fire at 10 ms).

A test circuit was then connected in which the protection system could function normally, but allowed the trip signal to be executed at a given location on the input voltage sine wave. This was done to determine if the system was sensitive to tripping on any particular part of the waveform. It was found that the circuit shutdown time is the same regardless of when tripped with respect to the input voltage waveform. The results of this test are shown in Figure 11. These pictures show the voltage measured across the load.

Inductive Load Tests

The inductive load was a 15-hp, 3-phase, 440-volt electric motor. To simulate remote operation, 1,000 feet of cable was used to connect the motor to the ground fault protection system. Another series of shutdown tests were conducted with the same test circuit used for the resistive load. Figure 12 shows the load voltage waveform from the time the trip signal was initiated until after the triacs turned on. Again the load voltage is zero at 10 ms, and no high transients were observed.

SUMMARY

The CEL ground fault protection system approach can provide divers a high degree of protection from electrical shock hazards. The system is designed to shut down on the first insulation breakdown in the protected circuit. This breakdown is detected by a DC current flow rather than an AC leakage current. The system as tested tripped on a DC leakage current of 1.65 mA, which is 35 times less than the DC let-go-level. AC current leakage on first fault is prevented by the isolation provided by the output transformer. Should two insulation breaks occur simultaneously, AC leakage currents could flow for a maximum of 10 ms since the trip circuit is activated on the first breakdown. The shutdown is accomplished by opening the ground fault circuit breaker and then shorting the protected circuit with the triacs. This provides a low impedance path to dissipate the energy stored in the protected circuit.

The system is designed to shut itself down if an internal equipment malfunction occurs. This is done by taking into account the normal failure mode of components - their de-energized state (loss of power to electronics) and monitoring the leakage-measuring circuits. The integrity of the DC circuit is monitored by the 10-kHz signal. Should an open circuit develop or the 10-kHz signal fail, the system will shut down.

The initial tests performed with small circuit breakers (15-ampere rating) indicate that this approach is directly applicable to low power (115-VAC, 15-ampere) systems. These systems could be used in any wet or electrically hazardous location as well as supplying underwater power. The operation of this system is as simple as turning on the circuit breaker.

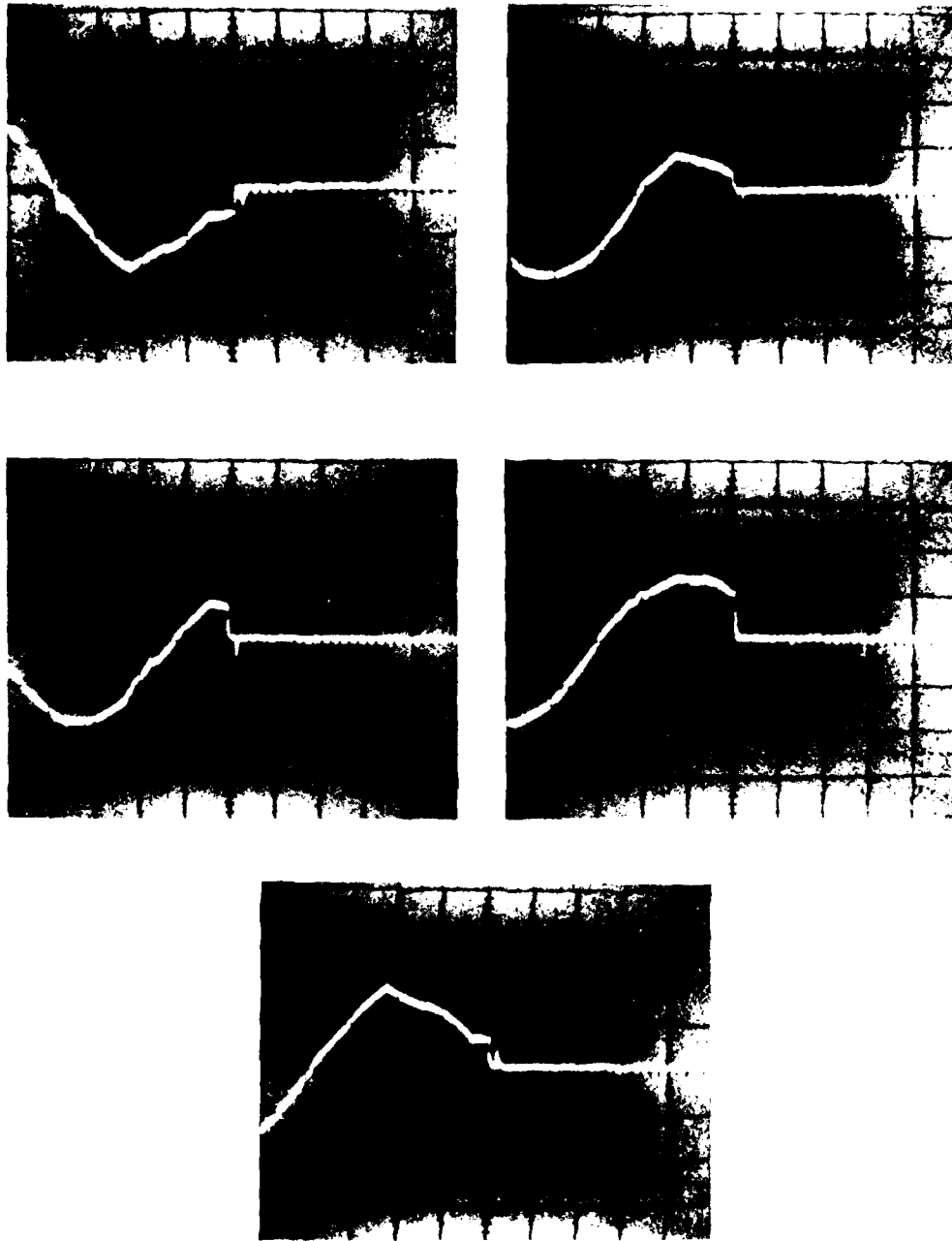

Figure 11. Wave shape of voltage to the 21KW resistive load when a ground fault occurs at various points on the wave.

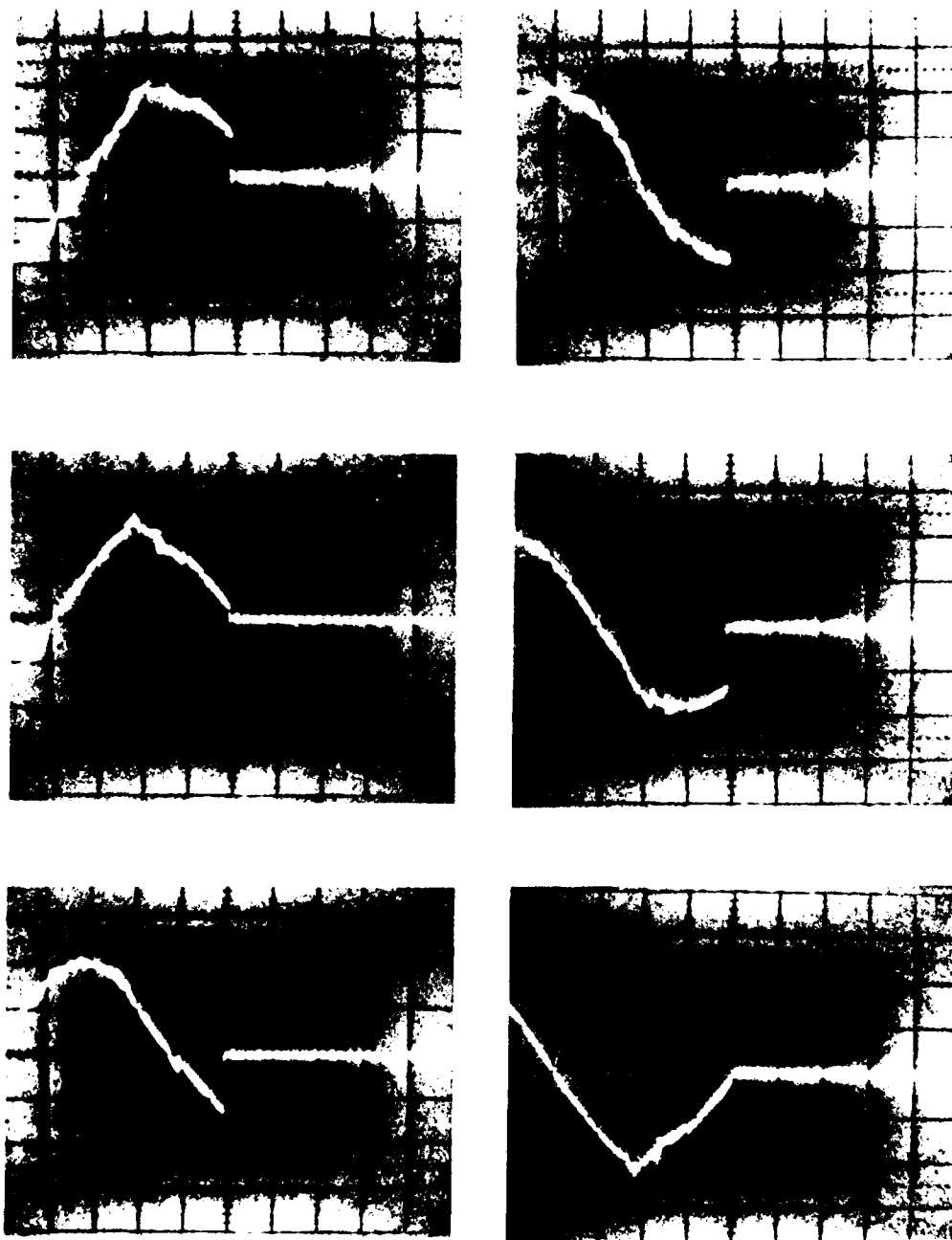

Figure 12. Wave shape of voltage to a 15 HP motor through 1000' of cable when a ground fault occurs at various points of the wave.

CONCLUSIONS

1. Ground fault protection systems based on the CEL fail-safe approach can provide the safety required for diver operation of electrically powered equipment. Furthermore, this approach should prove to be reliable under the severe operating environments typical of dive sites.

2. A breadboard model of a ground fault protection system capable of supplying 50 kVAC was built and successfully tested.

a. The system trips on resistances to ground of 50 kilohms or less from any of the three phases.

b. Trip time of the system is 10 ms.

c. Trip time of the ground fault system is not sensitive to polarity of the input voltage waveform.

d. The trip time of the system does not depend upon how the ground fault is applied. It can be a slowly decreasing resistance or a direct short circuit. Shutdown time is 10 ms.

e. No nuisance tripping was observed during the test program.

f. Correct timing between the operation of the circuit breaker and the turn on of the triacs must be obtained or severe arcing of the contacts in the circuit breaker results. Circuit shutdown in 10 ms allows time to open the breaker and then short the load with the triacs, thus eliminating the arcing.

3. The CEL approach can also be used to protect low power systems, i.e., lighting or hand tools, in hazardous locations other than underwater.

PLANS

The major portions of the detection and control circuits have been developed, but fast-acting high-current ground fault circuit breakers (100 amperes) are not commercially available. Development of a circuit breaker to meet CEL system requirements will continue. Subsequently, a 100-kW fail-safe prototype system will be built and tested underwater. In addition, a hand portable protection system will be built to demonstrate protection capability at lower power levels.

REFERENCES

1. International Electrochemical Commission. Publication 479: Effects of current passing through the human body.

2. Electrical Research Association. ERA 78-35: The safer use of electrical equipment underwater - guidance for methods of protection, by G. Mole. London, England, May 1978.

3. CIRIA Underwater Engineering Group. ISSN: 0305-4063. Feasibility of inherently-safe supplies for underwater use, by G. Mole and A. Parr. London, England, Nov 1975.

4. Electrical Research Association. ERA 71-183: Inherently-safe underwater electric power, by G. Mole. London, England.

5. _____. Report 2424/11: Final report on evaluation of earth-leakage circuit breakers for underwater power supplies, by G. Mole, H. Turner, and G. Rai. London, England, Aug 1975.

6. _____. Report 2425/10: Underwater electrical safety: Feasibility of a fail-safe method of protection, by S. G. Mole, et al. London, England, Jul 1975.

DISTRIBUTION LIST

AFB (AFIT/LD), Wright-Patterson OH; MAC/DET (Col. P. Thompson) Scott, IL; Stinfo Library, Offutt NE
ARMY ARRADCOM, Dover, NJ; DAEN-MPU, Washington DC; ERADCOM Tech Supp Dir. (DELS-D) Ft.
Monmouth, NJ
ARMY - CERL Library, Champaign IL
ARMY COASTAL ENGR RSCH CEN Fort Belvoir VA; R. Jachowski, Fort Belvoir VA
ARMY CRREL A. Kovacs, Hanover NH
ARMY DARCOM AMCPM-CS (J. Carr), Alexandria VA
ARMY MAT SYS ANALYSIS ACT Code DRXSY-CM (M Ogorzalek) Aberdeen Proving Grnd MD
ARMY MATERIALS & MECHANICS RESEARCH CENTER Dr. Leno, Watertown MA
ARMY MOBIL. EQUIP R&D COM Code DRXFB-MR Fort Belvoir VA; F Stora Fort Belvoir VA; Fuel Hndlng Equip
Br., Ft Belvoir, VA; Mr. Cevasco, Fort Belvoir MD
ARMY MTMC Trans Engr Agency (D F Eichhorn) Newport News VA
ARMY TRANSPORTATION SCHOOL MAJ T Sweeney, Code ATSP CD-TE Fort Eustis VA; V Quinby Code
ATSP-CPO-MS Fort Eustis VA
ARMY TRNG & DOCTRINE CMD Code ATCD-SP-L Fort Monroe VA
BUREAU OF RECLAMATION Code 1512 (C. Selander) Denver CO
CENTER FOR NAVAL ANALYSES Document Center (Darke), Arlington, VA
CNM Code 03462, Washington DC; Code 043 Washington DC
CNO Code NOP-964, Washington DC; Code OP 323, Washington DC; Code OP 405, Washington DC; Code OP 405,
Washington DC; Code OP 414 Washington DC; Code OP 414, Washington DC; Code OP 97 Washinton DC; Code
OP 97 Washington DC; Code OP 987 Washington DC; Code OP 987 Washinton DC; Code OP323 Washington DC;
Code OPNAV 09B24 (H); Code OPNAV 22, Wash DC; Code OPNAV 23, Wash DC
COMCBPAC Operations Off, Makalapa HI
COMDEVGRUONE San Diego, CA
COMFLEACT, OKINAWA PWO, Kadena, Okinawa
COMNAVBEACHPHIBREFTRAGRU ONE San Diego CA
COMOCEANSYS PAC SCE, Pearl Harbor HI
COMSUBDEVGRUONE Operations Offr, San Diego, CA
NAVSURFLANT Norfolk, VA
NAVSURFPAC San Diego, CA
COMOPTVFOR CDR, Norfolk, VA; Code 701A, San Diego, CA
DEFENSE INTELLIGENCE AGENCY Dir., Washington DC
DOE Dr. Cohen
DTNSRDC Anna Lab (Code 1175) Annapolis MD; Anna Lab (Code 1175) Annapolis MD; Anna Lab (Code 1568)
Annapolis MD; Code 2785 (Bloomquist), Annapolis, MD; Code 522 (Library), Annapolis MD
FMFPAC CG Pearl Harbor
HCU ONE CO, Bishops Point, HI
MARINE CORPS BASE First Service Support Group Camp Pendleton CA
MARINE CORPS HQS Code LFF-2, Washington DC
MCAS CO, Kaneohe Bay HI; Code S4, Quantico VA
MCDEC P&S Div Quantico VA
MCRD PWO, San Diego Ca
MILITARY SEALIFT COMMAND Washington DC
NAS Code 187, Jacksonville FL; Dir, Util, Div., Bermuda; PWD, Willow Grove PA; SCE, Barbers Point HI
NAVACT PWO, London UK
NAVCHAPGRU CO Williamsburg VA
NAVCOASTSYSCEN Code 719, Panama City, FL; Code 772 (C B Koesy) Panama City FL
NAVCOASTSYSTCTR CO, Panama City FL
NAVCOMMAREAMSTRSTA PWO, Wahiawa HI; SCE Unit 1 Naples Italy
NAVFLEXSYSCOM Code PME-124-61, Washington DC
NAVEODFAC Code 605, Indian Head MD
NAVEAC PWO, Guam
NAVEAC PWO, Lewes DE
NAVEACENGCOM Code 043 Alexandria, VA; Code 044 Alexandria, VA; Code 0451 Alexandria, VA; Code 0453 (D,
Potter) Alexandria, VA; Code 0453C, Alexandria, VA; Code 04B3 Alexandria, VA; Code 04B5 Alexandria, VA;

Code 06, Alexandria VA; Code 100 Alexandria, VA; Code 1113 (M. Carr) Alexandria, VA; Code PC-21, Alexandria, VA; P W Brewer Alexandria, VA; PC-2 Alexandria, VA

NAVFACENGCOM - CHES DIV, Code 405 Wash, DC; Code FPO-1 Wash, DC; Code FPO-11P, Wash, DC; Code FPO-1E, Wash, DC; FPO-1 (Spencer) Wash, DC; FPO-1 Wash, DC

NAVFACENGCOM - LANT DIV, Eur, BR Deputy Dir, Naples Italy; European Branch, New York

NAVFACENGCOM - NORTH DIV, Code 09P (LCDR A.J. Stewart); Code 114 (A. Rhoads); ROICC, Contracts, Crane IN

NAVFACENGCOM - PAC DIV, Code 402, RDT&E, Pearl Harbor HI; Commander, Pearl Harbor, HI

NAVFACENGCOM - WEST DIV, 112; AROICC, Contracts, Twentynine Palms CA

NAVFACENGCOM CONTRACT Eng Div dir, Southwest Pac, Manila, PI; OICC, Southwest Pac, Manila, PI; ROICC AF Guam; ROICC Off Point Mugu, CA; ROICC, Pacific, San Bruno CA

NAVHOSP I.T.R. Ejsbernd, Puerto Rico

NAVNUPWURU MUSE DET Code NPU-30 Port Hueneme, CA

NAVOCEANSYSCEN Code 31 San Diego, CA; Code 41, San Diego, CA; Code 52 (H. Talkington) San Diego CA; Code 5214 (H. Wheeler), San Diego CA; Code 5221 (R.Jones) San Diego Ca; Code 5311 San Diego, CA; Tech. Library, Code 447

NAVJSCOL E. Thornton, Monterey CA

NAVPHIBASE C O ACB ONE San Diego CA; CO, ACB 2 Norfolk, VA; COMNAVBEACHGRU TWO Norfolk VA; Dir, Amphib, Warfare Brd Staff, Norfolk, VA; Harbor Clearance Unit Two, Little Creek, VA

NAVREGMEDCEN SCE, Guam

NAVSCOLCECOFF C35 Port Hueneme, CA

NAVSEASYSYSCOM Code 00C-DG DiGeorge, Washington, DC; Code OOC (I.T.R. MacDougal), Washington DC; Code OOC-D, Washington, DC; Code PMS 395 A 3, Washington, DC; Code PMS 395 A2, Washington, DC; Code SEA OOC Washington, DC

NAVSEC Code 6034 (Library), Washington DC; Code 6156D, Washington, DC; Code 6157D, Washington, DC

NAVSECGRU ACT PWO, Adak AK

NAVSHIPYD; Code 202.4, Long Beach CA; Code 202.5 (Library) Puget Sound, Bremerton WA; Code 280, Mare Is., Vallejo, CA; Code 380, (Woodroff) Norfolk, Portsmouth, VA; Tech Library, Vallejo, CA

NAVSTA Dir Mech Engr, Gtmo; Engr, Dir., Rota Spain; Long Beach, CA; Maint, Cont. Div., Guantanamo Bay Cuba; PWD (I.T.G.P.M. Motolenich), Puerto Rico; PWO, Keflavik Iceland; SCE, Subic Bay, R.P.; Utilities Engr Off. (A.S. Ritchie), Rota Spain

NAVSUPPACT Code 4, 12 Marine Corps Dist, Treasure Is., San Francisco CA

NAVSURFWPNCEN PWO, White Oak, Silver Spring, MD

NAVTECHTRACEN SCE, Pensacola FL

PWC Code 420, Pensacola, FL

NCBC Code 10 Davisville, RI

NCR FWD 30th CDR Diego Garcia Island

NCSSO BAHRAIN Security Offr, Bahrain

NMCB Forty, CO; THREE, Operations Off.

NORDA Code 500, Bay St. Louis, MS

NTC OICC, CBU-401, Great Lakes IL

NUSC Code S332, B-80 (J. Wilcox); Code SB 331 (Brown), Newport RI; Code TA131 (G. De la Cruz), New London CT

OFFICE SECRETARY OF DEFENSE ASD (MRA&L) Code CSS/CC Washington, DC

ONR (Dr. E.A. Silva) Arlington, VA; BROFF, CO Boston MA; Code 221, Arlington VA

PMTCC Code 3144, Point Mugu, CA; EOD Mobile Unit, Point Mugu, CA

PWC Code 128, Guam; Code 600, Great Lakes, IL; Code 601, Oakland, CA; Code 700, Great Lakes, IL; Code 700, San Diego, CA

UCT TWO OIC, Norfolk, VA

U.S. MERCHANT MARINE ACADEMY Kings Point, NY (Reprint Custodian)

US NATIONAL MARINE FISHERIES SERVICE Highlands NY (Sandy Hook Lab-Library)

USCG (G-ECV) Washington Dc; (G-MP-3/USP/82) Washington Dc; G-EOE-4/61 (T. Dowd), Washington DC

USCG R&D CENTER CO Groton, CT; D. Motherway, Groton CT

USDA Forest Service, San Dimas, CA

USEUCOM (ECJ4/L-LO), Wright, Stuttgart, GE

USNA Ocean Sys. Eng Dept (Dr. Monney) Annapolis, MD; Oceanography Dept (Hoffman) Annapolis MD; PWD Engr. Div. (C. Bradford) Annapolis MD

CALIF. MARITIME ACADEMY Vallejo, CA (Library)

CALIFORNIA STATE UNIVERSITY LONG BEACH, CA (CHELAPATI); LONG BEACH, CA (YEN)

DAMES & MOORE LIBRARY LOS ANGELES, CA
 DUKE UNIV MEDICAL CENTER B. Muga, Durham NC
 FLORIDA ATLANTIC UNIVERSITY Boca Raton FL (W. Tessin); Boca Raton, FL (McAllister)
 IOWA STATE UNIVERSITY Ames IA (CE Dept. Handy)
 MICHIGAN TECHNOLOGICAL UNIVERSITY Houghton, MI (Haas)
 NATL. ACADEMY OF ENG. ALEXANDRIA, VA (SEARLE, JR.)
 NEW MEXICO SOLAR ENERGY INST. Dr. Zwibel Las Cruces NM
 OREGON STATE UNIVERSITY CORVALLIS, OR (CE DEPT. BELL); Corvallis OR (School of Oceanography)
 PENNSYLVANIA STATE UNIVERSITY STATE COLLEGE, PA (SNYDER)
 PURDUE UNIVERSITY Lafayette IN (Leonards); Lafayette, IN (Altschaeffl); Lafayette, IN (CE Engr. Lib)
 SAN DIEGO STATE UNIV. I. Noorany San Diego, CA
 SCRIPPS INSTITUTE OF OCEANOGRAPHY LA JOLLA, CA (ADAMS)
 SEATTLE U Prof Schwaegler Seattle WA
 SOUTHWEST RSCH INST R. DeHart, San Antonio TX
 TEXAS A&M UNIVERSITY College Station TX (CE Dept. Herbich); W.B. Ledbetter College Station, TX
 UNIVERSITY OF CALIFORNIA BERKELEY, CA (CE DEPT. MITCHELL); Berkeley CA (Dept of Naval Arch.);
 Berkeley CA (E. Pearson); DAVIS, CA (CE DEPT. TAYLOR); La Jolla CA (Acq. Dept. Lib. C-075A); SAN
 DIEGO, CA, LA JOLLA, CA (SEROCKI)
 UNIVERSITY OF DELAWARE Newark, DE (Dept of Civil Engineering, Chesson)
 UNIVERSITY OF HAWAII HONOLULU, HI (SCIENCE AND TECH. DIV.); Ocean Engrng Dept
 UNIVERSITY OF ILLINOIS URBANA, IL (NEWMARK)
 UNIVERSITY OF MASSACHUSETTS (Heronemus), Amherst MA CE Dept
 UNIVERSITY OF MICHIGAN Ann Arbor MI (Richart)
 UNIVERSITY OF NEW HAMPSHIRE DURHAM, NH (LAVOIE)
 UNIVERSITY OF RHODE ISLAND KINGSTON, RI (PAZIS); Narragansett RI (Pell Marine Sci. Lib.)
 UNIVERSITY OF WASHINGTON SEATTLE, WA (OCEAN ENG RSCH LAB. GRAY); SEATTLE, WA (PACIFIC
 MARINE ENVIRON. LAB., HALPERN); Seattle WA (E. Linger)
 UNIVERSITY OF WISCONSIN Milwaukee WI (Ctr of Great Lakes Studies)
 URS RESEARCH CO. LIBRARY SAN MATEO, CA
 AGBABIAN ASSOC. C. Bagge, El Segundo CA
 ALFRED A. YEE & ASSOC. Honolulu HI
 AMSCO Dr. R. McCoy, Erie, PA
 ARCAIR CO. D. Young, Lancaster OH
 ARVID GRANT OLYMPIA, WA
 ATLANTIC RICHFIELD CO. DALLAS, TX (SMITH)
 AWWA RSCH FOUNDATION R. Heaton, Denver CO
 BATTELLE-COLUMBUS LABS (D. Hackman) Columbus, OH
 BECHTEL CORP. SAN FRANCISCO, CA (PHELPS)
 BELGIUM HAECON, N.V., Gent
 BRAND INDUS SERV INC. J. Buehler, Hacienda Heights CA
 BRITISH EMBASSY Sci. & Tech. Dept. (J. McAuley), Washington DC
 CANADA Can-Dive Services (English) North Vancouver; Library, Calgary, Alberta; Mem Univ Newfoundland
 (Chari), St Johns; Nova Scotia Rsch Found. Corp. Dartmouth, Nova Scotia; Surveyor, Nenninger & Chenevert
 Inc., Montreal
 COLUMBIA GULF TRANSMISSION CO. HOUSTON, TX (ENG. LIB.)
 DRAVO CORP Pittsburgh PA (Wright)
 DURLACH, O'NEAL, JENKINS & ASSOC. Columbia SC
 EVALUATION ASSOC. INC KING OF PRUSSIA, PA (FEDELE)
 EXXON PRODUCTION RESEARCH CO Houston TX (A. Butler Jr); Houston, TX (Chao)
 FRANCE Dr. Dutertre, Boulogne; P. Jensen, Boulogne; Roger LaCroix, Paris
 GOULD INC. Shady Side MD (Ches. Inst. Div., W. Paul)
 GRUMMAN AEROSPACE CORP. Bethpage NY (Tech. Info. Ctr)
 MAKAI OCEAN ENGRNG INC. Kailua, HI
 JAMES CO. R. Girdley, Orlando FL
 LAMONT-DOHERTY GEOLOGICAL OBSERV. Palisades NY (Selwyn)
 LIN OFFSHORE ENGRG P. Chow, San Francisco CA
 LOCKHEED MISSILES & SPACE CO. INC. L. Trimble, Sunnyvale CA
 LOCKHEED OCEAN LABORATORY San Diego CA (F. Simpson)

MARATHON OIL CO Houston TX
MC CLELLAND ENGINEERS INC Houston TX (B. McClelland)
MCDONNELL AIRCRAFT CO. Dept 501 (R.H. Fayman), St Louis MO
MOBIL PIPE LINE CO. DALLAS, TX MGR OF ENGR (NOACK)
MOFFATT & NICHOL ENGINEERS (R. Palmer) Long Beach, CA
NORWAY J. Creed, Ski; Norwegian Tech Univ (Brandtzaeg), Trondheim
PACIFIC MARINE TECHNOLOGY Long Beach, CA (Wagner)
PORTLAND CEMENT ASSOC. SKOKIE, IL (CORLEY; SKOKIE, IL (KUEGER); Skokie IL (Rsch & Dev Lab. Lib.)
SANDIA LABORATORIES Library Div., Livermore CA; Seabed Progress Div 4536 (D. Talbert) Albuquerque NM
SCHUPACK ASSOC SO. NORWALK, CT (SCHUPACK)
SHELL DEVELOPMENT CO. Houston TX (C. Sellars Jr.)
SHELL OIL CO. HOUSTON, TX (MARSHALL); Houston TX (R. de Castongrene)
SWEDEN GeoTech Inst; VBB (Library), Stockholm
TRW SYSTEMS CLEVELAND, OH (ENG. LIB.)
UNITED KINGDOM Cement & Concrete Assoc Wexham Springs, Slough Bucks; Cement & Concrete Assoc. (Library), Wexham Springs, Slough; D. New, G. Maunsell & Partners, London; J. Derrington, London; Library, Bristol; Shaw & Hatton (F. Hansen), London; Taylor, Woodrow Constr (Stubbs), Southall, Middlesex; Univ. of Bristol (R. Morgan), Bristol
WESTINGHOUSE ELECTRIC CORP., Annapolis MD (Oceanic Div Lib, Bryan)
WOODWARD-CLYDE CONSULTANTS PLYMOUTH MEETING PA (CROSS, III)
BRAHTZ La Jolla, CA
BRYANT ROSE Johnson Div, UOP, Glendora CA
BULLOCK La Canada
LAYTON Redmond, WA
CAPT MURPHY Sunnyvale, CA
T.W. MERMEL, Washington DC
WM TALBOT Orange CA