

AD-A092 059

NAVAL OCEAN SYSTEMS CENTER SAN DIEGO CA
HARDWARE AND PERFORMANCE EVALUATION: TETHERED FLOAT BREAKWATER --ETC(U)
JUL 80 J D CLINKENBEARD

F/6 13/2

UNCLASSIFIED

NOSC/TR-574

NL

1 of 2

NOSC

06.000

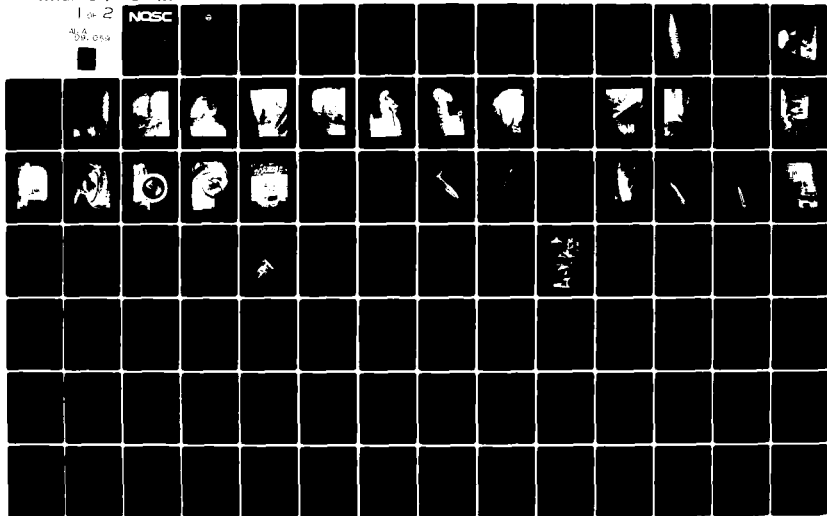

AD A092059

NOSC

NOSC TR 574

LEVEL II

12

NOSC TR 574

Technical Report 574

HARDWARE AND PERFORMANCE EVALUATION: TETHERED FLOAT BREAKWATER NEAR-SHORE OCEAN MODEL

JD Clinkenbeard
July 1980

Final Report: April 1978 - February 1980

Prepared for:
Naval Facilities Engineering Command

DTIC
1980

Approved for public release; distribution unlimited

DDC FILE COPY

NAVAL OCEAN SYSTEMS CENTER
SAN DIEGO, CALIFORNIA 92152

8011 06 052



NAVAL OCEAN SYSTEMS CENTER, SAN DIEGO, CA 92152

AN ACTIVITY OF THE NAVAL MATERIAL COMMAND

SL GUILLE, CAPT, USN

Commander

HL BLOOD

Technical Director

ADMINISTRATIVE INFORMATION

The work discussed in this report was performed from April 1978 to February 1980. The task was funded by the Naval Facilities Engineering Command (work request N00025-80-WR-00403).

Released by
AJ Schlosser, Head
Applied Technology Division

Under authority of
HR Talkington, Head
Ocean Technology Department

METRIC CONVERSION

1 foot 0.3 m
1 pound 0.45 kg

UNCLASSIFIED

SECURITY CLASSIFICATION OF THIS PAGE (When Data Entered)

REPORT DOCUMENTATION PAGE		READ INSTRUCTIONS BEFORE COMPLETING FORM
1. REPORT NUMBER NOSC Technical Report 574 (TR 574)	2. GOVT ACCESSION NO. AD-A092	3. RECIPIENT'S CATALOG NUMBER 059
4. TITLE (and Subtitle) <u>HARDWARE AND PERFORMANCE EVALUATION: TETHERED FLOAT BREAKWATER NEAR-SHORE OCEAN MODEL</u>	5. TYPE OF REPORT & PERIOD COVERED Final Report April 1978 - February 1980	
	6. PERFORMING ORG. REPORT NUMBER	
7. AUTHOR(s) D. Clinkenbeard	8. CONTRACT OR GRANT NUMBER(s) N00025-80-WR-00403	
9. PERFORMING ORGANIZATION NAME AND ADDRESS Naval Ocean Systems Center San Diego, CA 92152	10. PROGRAM ELEMENT, PROJECT, TASK AREA & WORK UNIT NUMBERS N00025-80-WR-00403	
11. CONTROLLING OFFICE NAME AND ADDRESS Naval Facilities Engineering Command Alexandria, VA 22332	12. REPORT DATE July 1980	
	13. NUMBER OF PAGES 122	
14. MONITORING AGENCY NAME & ADDRESS (if different from Controlling Office) (14) NOSC/TR-574	15. SECURITY CLASS. (of this report) Unclassified	
	15a. DECLASSIFICATION/DOWNGRADING SCHEDULE	
16. DISTRIBUTION STATEMENT (of this Report) Approved for public release; distribution unlimited.		
17. DISTRIBUTION STATEMENT (of the abstract entered in Block 20, if different from Report)		
18. SUPPLEMENTARY NOTES		
19. KEY WORDS (Continue on reverse side if necessary and identify by block number) Breakwaters Marine biology Military oceanography		
20. ABSTRACT (Continue on reverse side if necessary and identify by block number) A Tethered Float Breakwater was installed off Imperial Beach, California, on 12 April 1978. The primary purpose was hardware verification. Its ability to survive in the ocean environment was evaluated over a 22-month period. Also evaluated were corrosion resistance, marine fouling, abrasion, burial, and scouring. The feasibility of a breakwater system that can be towed to an operational site, installed with a minimum of support equipment, and later removed or relocated was demonstrated. Routine maintenance and replacement of components were performed in the open ocean.		

(Continued)

DD FORM 1 JAN 73 1473

EDITION OF 1 NOV 65 IS OBSOLETE
S/N 0102-LF-014-6601

UNCLASSIFIED
SECURITY CLASSIFICATION OF THIS PAGE (When Data Entered)

3111

UNCLASSIFIED

SECURITY CLASSIFICATION OF THIS PAGE (When Data Entered)

20. Continued.

The program verified the wave attenuation capability of a full-scale bottom resting system and the ability of the computer model to predict this performance over a broad range of conditions. The ability of a Tethered Float Breakwater to provide an otherwise barren area with an artificial habitat for marine flora and fauna was demonstrated.

UNCLASSIFIED

SECURITY CLASSIFICATION OF THIS PAGE (When Data Entered)

OBJECTIVES

Demonstrate the feasibility of a portable breakwater system that can be towed to an operational site, installed with a minimum of support equipment, and later removed or relocated. Evaluate hardware performance.

Perform routine maintenance and replacement of components (floats and tethers) in the open ocean.

Evaluate ability of the Tethered Float Breakwater to reduce wave height.

RESULTS

Results of the experiment indicate that the present ballast assembly can withstand loads imposed during installation and relocation, and will not deteriorate during typical deployment periods. Tire floats are satisfactory for one-time usage or short-term installations; a molded configuration is recommended, however. Further development of tether terminations is required to reach the original design goal of a five-year life expectancy.

The program verified the wave attenuation capability of a full-scale bottom resting system, and the ability of the computer model to predict this performance over a broad range of conditions.

CONCLUSIONS

Larger breakwaters, containing many more rows of floats, can be designed with confidence in their ability to reduce wave height.

A Tethered Float Breakwater can provide an otherwise barren area with an artificial habitat for marine flora and fauna, as sea life is attracted to this type of installation in a relatively short time.

Accession For	
NTIS Grant	<input checked="" type="checkbox"/>
DDC TAB	<input type="checkbox"/>
Unannounced	<input type="checkbox"/>
Justification	
By _____	
Distribution/ _____	
Availability Codes	
Dist.	Avail and/or special
A	

CONTENTS

INTRODUCTION . . .	page 5
INSPECTIONS . . .	8
MARINE FOULING . . .	10
BALLAST ASSEMBLY . . .	19
FLOATS . . .	22
TETHERS . . .	29
TFB OCEAN MODEL REFURBISHMENT . . .	41
SYSTEM PERFORMANCE . . .	43
TERMINATION OF THE OCEAN EXPERIMENT . . .	45
RELATED TFB EXPERIMENTS . . .	45
RECOMMENDATIONS . . .	46
CONCLUSIONS . . .	48
REFERENCES . . .	49
APPENDIX A: MARINE FOULING . . .	51
APPENDIX B. SETTLING OF BALLAST DUE TO SCOURING . . .	55
APPENDIX C. WEIGHTS OF RECOVERED FLOATS . . .	61
APPENDIX D. REPORT OF FAILURE ANALYSIS . . .	65
APPENDIX E. MEAN TIME TO FAILURE AND STANDARD DEVIATION CALCULATIONS . . .	71
APPENDIX F. LOCATION OF MISSING FLOATS . . .	75
APPENDIX G. EXCERPTS FROM SIO TECHNICAL NOTE NO. 17, SILVER STRAND TETHERED FLOAT BREAKWATER INTERIM REPORT, DAVID CASTEL, OCT. 1979 . . .	91
APPENDIX H. TFB PERFORMANCE CURVES AND TABULATED DATA . . .	101

ILLUSTRATIONS

Figure

1	Tethered Float Breakwater Ocean Model installation site . . .	page 6
2	Tethered Float Breakwater Ocean Model (one module) . . .	7
3	Underwater inspection of float and tether . . .	9
4	On-site inspection of termination boot . . .	9
5	Hydroid colony on tether boot . . .	11
6	Algae and hydroids on tether and rail . . .	12
7	Marine fouling at corner of ballast assembly . . .	13
8	Algae encrusted valves and rail . . .	14
9	Fully developed marine growth on rails . . .	15
10	Mussels on underside of float and tether . . .	16
11	Mussel colony on tether (4 feet long) . . .	17
12	Recessed area of float inhabited by mussels . . .	18

13	Lower longitudinal rail partially buried . . .	page 20
14	Corner of ballast scoured in . . .	21
15	Recovered float showing tire separation . . .	23
16	Float with missing tire and foam . . .	24
17	Tire separation and damaged polyurethane foam . . .	25
18	Void caused by sawing action of reinforcing rod . . .	26
19	Recovered float showing hollow core . . .	27
20	Tire float used for refurbishment . . .	28
21	Molded variable density float . . .	29
22	Termination boot after tether failure . . .	31
23	Tether showing clean break in line . . .	32
24	Tether abraded at float attachment point . . .	34
25	Boot cracked at top of tether socket . . .	35
26	Modified tether assembly (Type B) . . .	36
27	Modified tether assembly installed on ballast . . .	37
28	Tether failures (total) vs life cycle . . .	39
29	Tether failures (incremental) vs life cycle . . .	39
30	Failure percentage (incremental) vs life cycle . . .	40
31	Refurbished TFB configuration . . .	41
32	Bolt-on tether socket . . .	42
33	Attachment of bolt-on tether socket . . .	42
34	Location of wave gages . . .	43
35a	Ball and socket tether termination -- disassembled . . .	47
35b	Ball and socket tether termination -- assembled . . .	47

TABLES

1	Type of tether failure . . .	page 30
2	Record of missing floats due to tether failure . . .	38
3	Mean time to failure of tethers . . .	40
4	Average energy and height transmission ratios . . .	45

INTRODUCTION

The Tethered Float Breakwater (TFB) Ocean Model was installed off Imperial Beach, CA, on 12 April 1978. The primary purpose of the TFB Ocean Experiment was hardware performance verification. Its ability to survive in the ocean environment was evaluated over a 22-month period. Areas of interest included corrosion resistance, marine fouling, abrasion, burial, and scouring. A secondary goal was performance evaluation, i.e. its ability to reduce wave height. The project was terminated on 11 February 1980 with the removal of the remaining floats. The ballast sections were left in place as platforms for future test and evaluation.

The test site (figure 1), approximately 250 yards off shore, was subjected to open ocean waves throughout the year, ranging from northwest in winter to south in summer. The seafloor was firm, level sand. Water depth was 25 feet at mean lower low water. The significant wave height ranged from 1 to 5 feet with a yearly average of 3 feet; the wave period was 6 to 10 seconds.

Figure 2 illustrates one module of the TFB Ocean Model. High density cylindrical floats (128 per module) constructed from used automobile tires were attached to the ballast with synthetic tethers. The bottom-resting framework (30 ft by 60 ft) was fabricated from scrap rail and four steel ballast tanks which enabled the assembly to be refloated and transported to a new location.

The design, construction, and installation of the TFB Ocean Model are discussed in detail in reference 1. A 90-degree rotation of both assemblies, conducted on 14 June 1978, and a relocation experiment, performed on 2 August 1978, are also described there. Both exercises were successfully completed, thus verifying the portability of the TFB system.

1. NOSC TR 378, Engineering Report: Tethered Float Breakwater Near-Shore Ocean Model.
J Clinkenbeard, Sept. 1978.

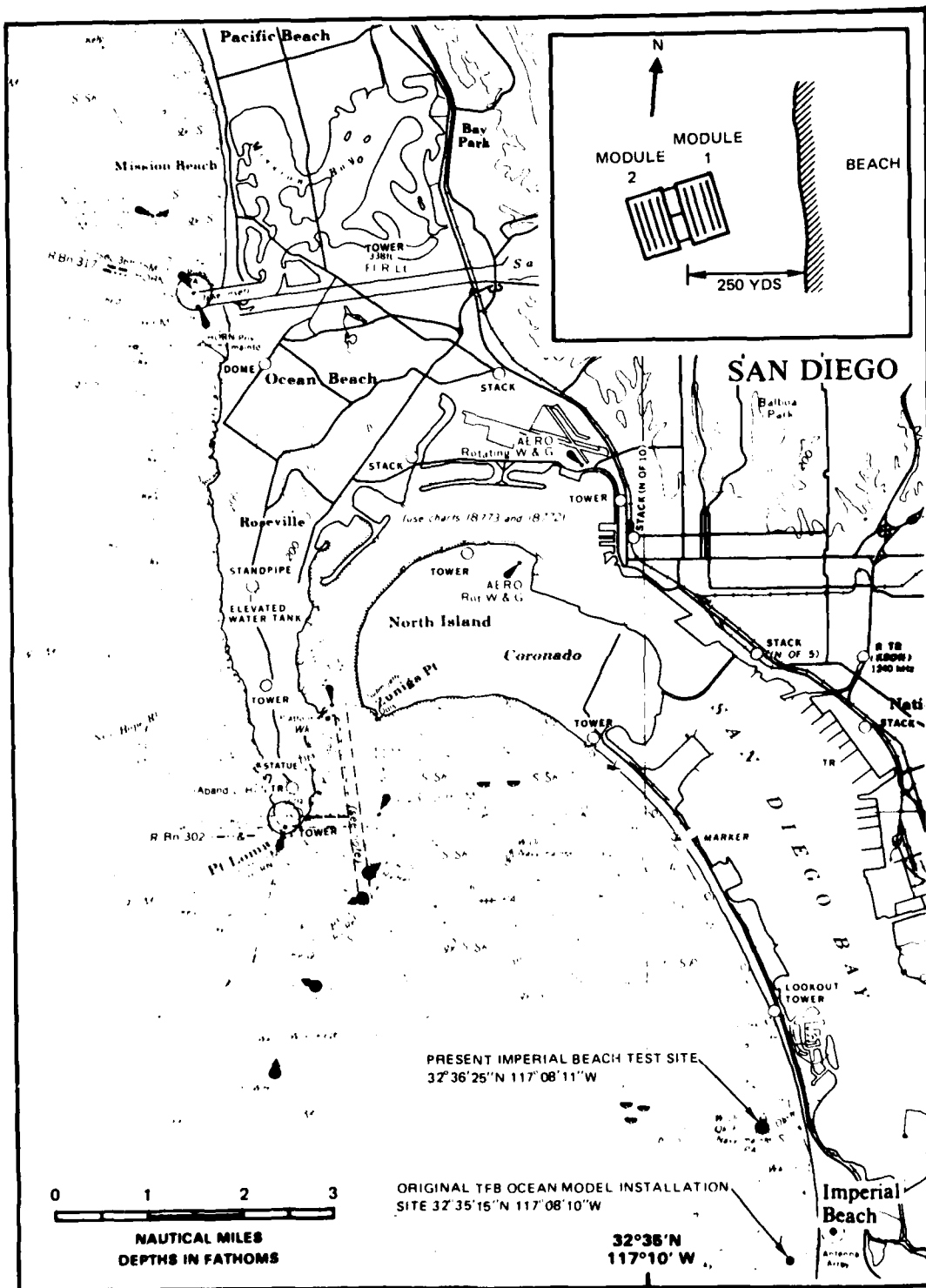

Figure 1. Tethered Float Breakwater Ocean Model installation site.

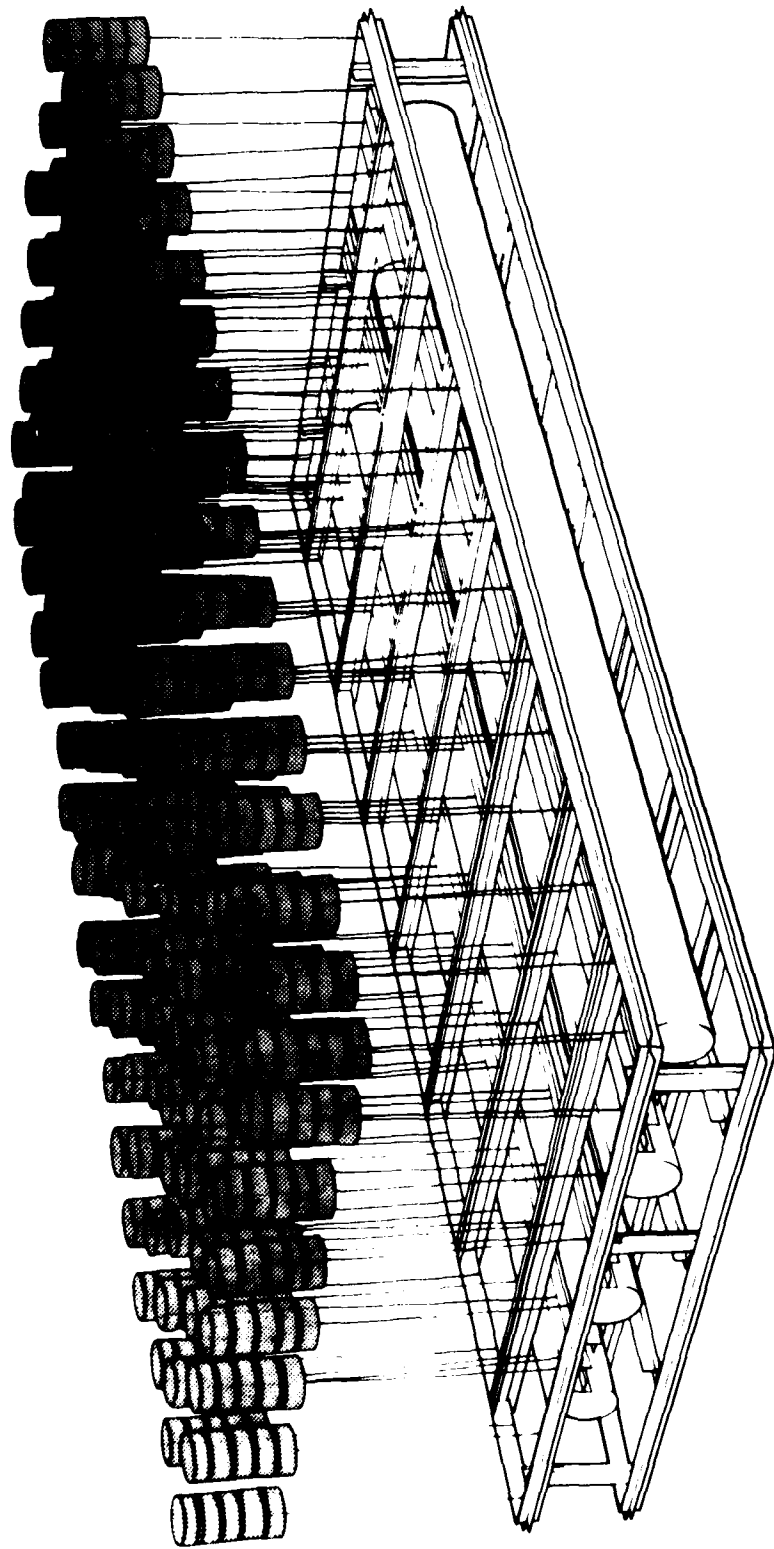

Figure 2. Tethered Float Breakwater Ocean Model (one module).

INSPECTIONS

Hardware inspections were performed on a regular basis throughout the TFB Ocean Experiment. The integrity of individual floats was monitored: tethers were checked for abrasion and fiber separation at both bail and termination (figure 3); termination boots were inspected for cracks and any reduction in elasticity (figure 4), and the ballast for corrosion, scouring, and burial.

Underwater inspections were conducted on the following dates: 12 April 1978 (installation), 20 April, 11 May, 1 June, 13 & 14 June (90-degree rotation), 29 June, 2 August (relocation), 5 October, 25 October, 7 November, 30 November, 12-14 December (tether replacement), 13 February 1979, 19 April, 29 May - 5 June (refurbishment), 17 July, 27 September, 22 January 1980, and 11 February (float removal).

Bottom visibility at the Imperial Beach test site ranged from zero to ten feet (2-3 ft average), depending on wave activity and amount of surge. During some dives, hardware inspection was literally performed by feel, since visibility was virtually nonexistent.

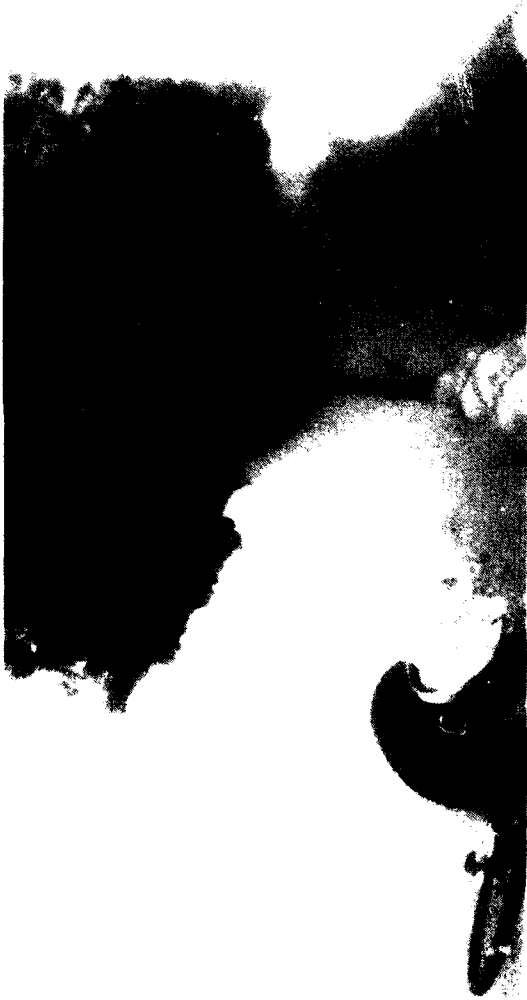

Figure 3. Underwater inspection of float and tether.



Figure 4. On-site inspection of termination boot.

MARINE FOULING

All components of the TFB were subject to marine fouling to various degrees. In the relatively short period of 2 weeks, algae started to grow on the floats, tethers, and ballast structure. This was followed by colonies of hydroids and barnacles. Small fish, crabs, and an occasional lobster found refuge among the rail and floats. At one point, the float field became a breeding station for nudibranchia.

The rate of growth was accelerated on the seaward ballast structure (unit no. 2). This was probably due to greater water circulation. In many cases, algae and hydroids 2-4 inches long flourished on the tethers (figures 5 and 6), whereas similar growth on the ballast tanks and rails took longer to become established (figures 7, 8 and 9). The upper portion of some tethers served as an attachment point for colonies of mussels (figures 10 and 11). Barnacles were most prevalent on the underside of the floats and on the bails. The recessed area between tires was commonly inhabited by mussels (figure 12). Appendix A describes general conditions during several inspection dives.

The nature and amount of marine fouling had no measurable effect on system performance. This was not the case with the TFB Bay Model where the thickness of the growth layer on the floats was large compared to their diameter.

A Tethered Float Breakwater can enhance the ecology of an otherwise barren area by providing an artificial habitat for marine flora and fauna.



Figure 5. Hydroid colony on tether boot.



Figure 6. Algae and hydroids on tether and rail.



Figure 7. Marine fouling at corner of ballast assembly.



Figure 8. Algae encrusted valves and rail.



Figure 9. Fully developed marine growth on rails.



Figure 10. Mussels on underside of float and tether.



Figure 11. Mussel colony on tether (4 feet long).



Figure 12. Recessed area of float inhabited by mussels.

BALLAST ASSEMBLY

The complete ballast assembly (including tanks, rail and plumbing (see ref 1)) satisfactorily withstood the marine environment for a period of 22 months. All structural components remained intact. The rotation and relocation experiments did not impose any excess stresses on the members. Ballast tanks and valves functioned without difficulty throughout the experiment.

Twenty-eight sacrificial zinc anodes (24 lbs each) bolted to the tank straps for cathodic protection of the steel members proved to be adequate for a period of approximately 10 months. (The framework was not painted due to cost considerations.) After the initial 6 months, about 30% to 50% of the zinc mass remained. In February 1979, zincs measured only $1/2 \times 3 \times 9$ inches, an 85% reduction in volume (original size was $1-1/4 \times 6 \times 12$ inches). Corrosion occurred at a very slow, uniform, and acceptable rate over the entire structure. It was most apparent on the mild steel tether sockets (2.50 inch O.D. \times 2.125 inch I.D. \times 5-inch-long tubing) and retaining pins (0.75 inch dia \times 3.50 inches long) which were a different chemical composition than the rail (0.18 - 0.23 carbon, 0.30 - 0.60 manganese vs. 0.67 - 0.80 carbon, 0.70 - 1.00 manganese). Zincs should be replaced at 8-10 month intervals to ensure continued corrosion protection for extended deployment periods. This maintenance procedure was not performed during the Ocean Experiment. The corrosion rate increased in early 1979 after the zinc had deteriorated.

Scouring and burial tendencies of the ballast assembly were important factors in evaluating the survivability and recoverability of the TFB modules. A summary of observations made during inspection dives is given in appendix B. Although complete burial of a module did not occur, both units settled into the seafloor to a depth of 18 inches due to scouring over the initial one-week period (figures 13 and 14) when ballast tanks were perpendicular to the beach. After 7 weeks, the assemblies were 24 inches below the normal seafloor. Following the relocation experiment of 2 August 1978 (tanks now parallel to the beach), the modules settled 18 inches after a 9-week period. This increased to 24 inches for module 1 (leeward assembly) and 36 inches for module 2 (seaward) during the next 3 weeks. The seaward tank on unit 2 became 3-4 buried over half of its length. This condition reversed itself over the next month. By February 1979, the lower rails of each assembly were 30-36 inches below the seafloor. Tank 7 (module 2) was 25% buried over a length of 5 feet; tank 8 was 50% buried over the same distance. On 27 September, both modules were found to be scoured in only 18-24 inches. In January 1980, the units were again scoured in 30-36 inches on all sides. One corner of ballast 1 was completely buried. The maximum depth varied throughout the year with wave climate.

Based on the initial two-month installation period at each test site, the rate of scouring was not significantly influenced by the orientation of the ballast tanks with respect to the beach. The maximum scour depth attained during the Ocean Experiment at the Imperial Beach test site was about 36 inches. This depth was reached in approximately 3 months. The ballasts remained at a constant level throughout most of the summer. The extent of scouring will vary with different bottom conditions, wave climate, or other types of TFB ballast assemblies.

The ability to recover and relocate the TFB Ocean Model has been successfully demonstrated. Scouring has little effect on this capability; however, burial may. Test conditions did not provide an opportunity to evaluate forces and times required for breakout if ballast assemblies were partially or completely buried.



Figure 13. Lower longitudinal rail partially buried.



Figure 14. Corner of ballast scoured in.

FLOATS

The TFB floats, fabricated from automobile tires, polyurethane foam and concrete (see ref 1), survived reasonably well in the ocean environment until tether failure occurred and the floats were set adrift. Damage was then sustained by some units while they washed through the surf zone and tumbled about on the beach.

While rolling up and down the sand, many individual tires became separated from the reinforcing rod (rebar), as shown in figures 15, 16 and 17. Some became completely detached, sliding off over the bail. The rolling action of the float resulted in the rebar sawing its way through the foam (figures 18 and 19), causing a void in the core. Chunks of polyurethane (and buoyancy) were subsequently lost.

Because of water absorption, float density gradually changed during the experiment. The inner volume of the tires was foamed with polyurethane; in-place density (during float production) was 3.22 lb/cu. ft. The minimum compressive strength (direction perpendicular to rise) was 34 psi, 5.5 times the ambient pressure at the test depth (about 14 feet to the center of the float at high tide). Although the foam did not compress, it did absorb a large amount of water. Several floats were inspected after recovery from the beach (October-November 1978) and found to be overweight by as much as 171 lb (new floats averaged 515 lb with a 920 lb displacement). This represents a 42% reduction in buoyancy. Float density (ratio of dry weight to displacement) increased from 0.56 to 0.75; this has a negative effect on the breakwater's ability to reduce the height of the design wave since the natural frequency of the system is reduced. Appendix C lists float conditions and weights. Average weight was 575 lb; this results in a buoyancy decrease of 15% and a float density of 0.63.

Naval Construction Battalion (CB-1) personnel assisted in the recovery of 194 original floats (out of 204 lost) from a 6-mile section of beach between Coronado and Imperial Beach. In late May 1979, the Ocean Model was refurbished using 146 of these units that had remained structurally intact (figure 20). In most cases, however, their buoyancy was less than the original design value, since absorbed water was retained.

Although tire floats initially seemed practical from a cost and ecological standpoint, the handling problems, loss of buoyancy, and difficulties encountered following tether failure indicate that a more reliable method of float construction would be beneficial for long term deployment. Figure 21 illustrates a molded float with a hollow core. This design weighs approximately 80 lb (vs 515 lb). Entrapped water within the void provides most of the effective in-water mass. At the time of fabrication, the volume of the inner shell can be modified, resulting in a variable density float.



Figure 15. Recovered float showing tire separation.



Figure 16. Float with missing tire and foam



Figure 17. Tire separation and damaged polyurethane foam.



Figure 18. Void caused by sawing action of reinforcing rod.



Figure 19. Recovered float showing hollow core.



Figure 20. Tire float used for refurbishment.

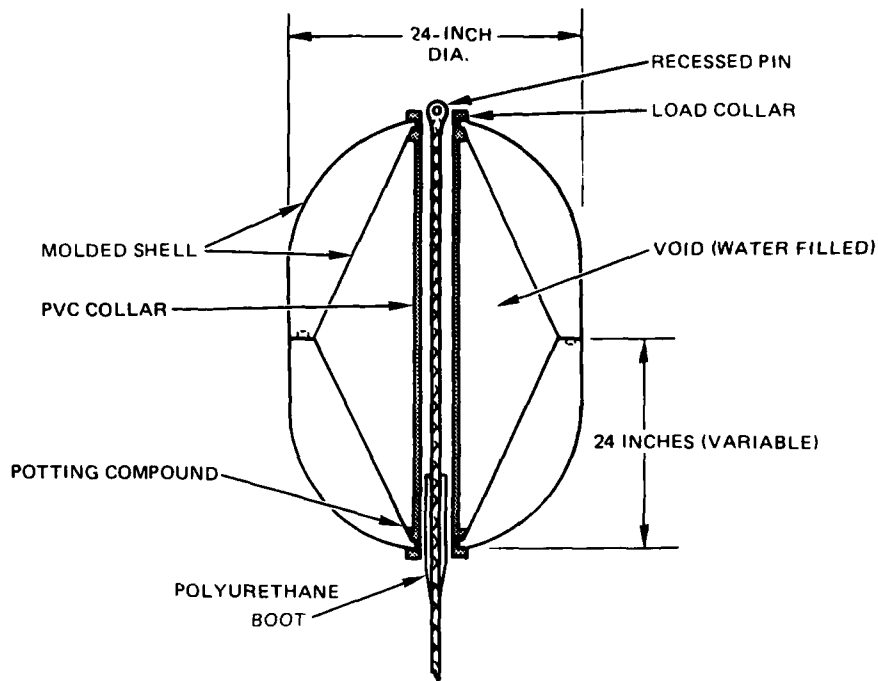

Figure 21. Molded variable density float.

TETHERS

The original synthetic tether assemblies (3/8-inch-dia. Samson VLS with molded polyurethane boot (see ref 1)) functioned properly during the initial six months of the Ocean Experiment. In November 1978, however, the units started to fail. The rate increased with time. By February 1979, 204 (80%) of the original 256 tethers had failed in one of four modes: (1) line separation at top of boot; (2) line chafed at bail attachment; (3) line parted between boot and bail; or (4) boot and line severed at top of tether socket. Table 1 lists dates tethers and floats were recovered from the beach, and the mode of failure.

The majority of the tether separations (92% of the original units recovered) occurred at the same location in the line—a discontinuity 1/2 to 1 inch above the boot. This change in tether cross-section resulted from terminating the eye splice at the lower end of the tether. Figures 22 and 23 illustrate this type of failure. Note that all line fibers are approximately the same length, indicating a possible cutting action.

A few samples were removed from the test site and inspected in the laboratory. A video recording was made of actual in-water motion of a typical tether assembly. Upon analysis of the tape and sections of recovered tethers, the cause of failure was determined to be a combination of nonuniform axial loading and internal abrasion of the fibers.

Lane Instrument Co., manufacturer of the tethers, performed a failure analysis of the parts in question. Findings are stated in appendix D. Lane concluded that the molded boot

Table 1. Type of tether failure.

Date Recovered	Failure Mode	No.	
12 Apr 78	4	1	
1 May	1	2	
	2	1	
16 May	1	1	
	3	1	
19 May	1	1	
	2	1	
19 June	3	1	
25 June	1	1	
	2	1	
29 June	2	2	
5 July	1	1	
11 Oct	1	6	
23 Oct	1	6	
29 Nov	1	15	
3 Jan 79	1	18	
	4	1	
	5	1	
4 Jan	1	36	
2 Feb	1	36	
6 Feb	1	23	
9 Feb	1	8	
13 Mar	1	20	
	5	1	
14 June	1	5	
	2	4	
16 Jan 80	1	11	} After Refurbishment
	2	18	
	3	16	
TOTALS		All Units	Original Units
	1	190	179
	2	27	9
	3	18	2
	4	2	2
	5	2	2
	239	194	

- Failure Mode -
- 1 Line separation at top of boot
 - 2 Line chafed at bail attachment
 - 3 Line parted between boot and bail
 - 4 Tether socket weld failure
 - 5 Boot severed at top of socket

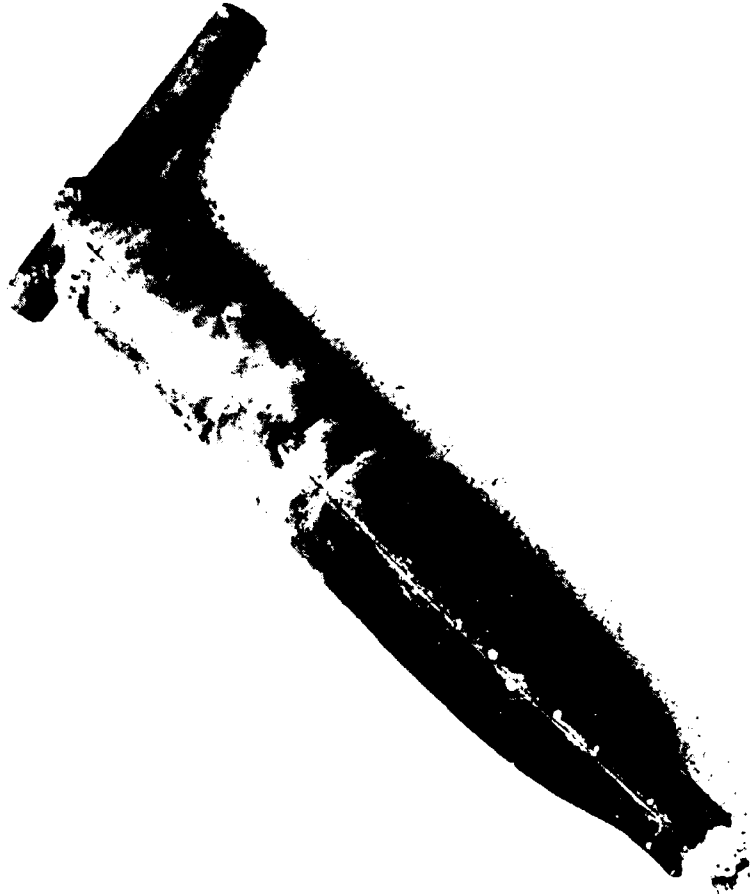

Figure 22. Termination boot after tether failure.



Figure 23. Tether showing clean break in line.

was functioning properly; the line was not bending at the point of failure. This precluded flexural fatigue as a primary cause. Repeatability of the mode of failure assigned the cause to the transition of double braid to single braid at the buried end of the splice, just above the top of the boot. This zone can entrap solid particulate matter within the line core which, under a cycling axial load, could abrade the individual filaments in the line, leading to the type of failure observed.

Several tether failures (5%) occurred at the bail of the float due to increased stress and abrasion. (Following refurbishment of the breakwater in June 1979, this failure mode accounted for 11% of the total.) In new float construction, the center of gravity (CG) coincides with the center of buoyancy (CB); this ensures dynamic stability. As a float absorbs water nonsymmetrically about its longitudinal axis, the CG and CB separate. This causes irregular float motion to occur during each oscillation of the system. The result is flexing of the tether at the bail attachment point. Stress in the fibers, as well as the abrasion between the bite and standing part of the line, is increased. The "cow hitch" method of attachment to the float bail created three points of wear. Two points of abrasion were where the line makes contact with the bail on the float. The third was where the "cow hitch" bite contacts the standing part of the line at the bottom of the eye splice (figure 24).

In a few cases, tethers parted midway between the boot and bail. This type of failure can be attributed partially to nonuniform axial loading. Internal abrasion may also have been a factor, since this part of the tether was not impregnated.

Two boots cracked at the top of the tether socket (figure 25). This resulted from insufficient radius on the inner edge of the tether socket which caused concentrated bending stress.

In an effort to substantially reduce the failure rate, the tether design was modified. The basic configuration remained unchanged. However, a low modulus elastomer was used to impregnate and encapsulate the line at the buried end of the splice to prevent entrance of particulate matter into the line core, and minimize fiber-to-fiber abrasion during cyclic axial loading. During 12-14 December 1978, 36 tethers were replaced in the field with two modified versions. Type A was original construction, but with the area above the boot impregnated with polyurethane for a length of 7 inches. The end of the eye splice was lengthened in Type B to extend 6 inches above the boot to further separate the line discontinuity from the molded termination; the tether was impregnated as in Type A. Modifications to tether assemblies (Types A and B) also included lengthening and impregnating the upper eye splice to guard against abrasion at the bail. Figure 26 shows a modified tether assembly (Type B). These proved to be more durable than the former design. Internal abrasion at the lower termination is no longer considered a problem. During the Ocean Model refurbishment in late May 1979, Type B assemblies were used exclusively. A new unit is shown installed in figure 27.

A record of tether failures is presented in table 2 according to date of inspection, life cycle of the units, and number involved. From 12 April 1978 to 5 June 1979, only the original tether assemblies were involved in a failure mode. After 5 June (breakwater refurbishment), the experiment included new tethers (Type B), previously installed modified assemblies (Types A and B), and a few remaining original tethers (178 total). Data are represented graphically in figures 28, 29, and 30.



Figure 24. Tether abraded at float attachment point.



Figure 25. Boot cracked at top of tether socket.



Figure 26. Modified tether assembly (Type B).



Figure 27. Modified tether assembly installed on ballast.

Table 2. Record of missing floats due to tether failure.*

Date	Days	Total Missing	Δ Missing	$\Delta\%$	Average Failures/Day
12 Apr 78	0	0	0	0	0
20 Apr	3	3	3	1.2	0.08
11 May	29	7	4	1.6	0.24
1 June	50	10	3	1.2	0.20
29 June	78	15	5	2.0	0.19
5 Oct	176	30	15	5.9	0.17
25 Oct	196	38	8	3.1	0.19
30 Nov	232	56	18	7.0	0.24
14 Dec	246	112	56	21.9	0.46
13 Feb 79	307	204	92	35.9	0.66
5 June	420	211	7	2.7	0.50
TFB Refurbishment					
5 June	0	0	0	0	0
17 July	42 (216)	7	4 ¹ 3 ²	2.7 8.3	0.17
27 Sept	114 (288) (534)	12	1 ¹ 3 ² 1 ³	0.7 8.3 0.4	0.11
22 Jan 80	231 (405) (651)	114	77 ¹ 21 ² 4 ³	52.7 58.3 1.6	0.49

Δ = Number Missing Since Last Inspection
 $\Delta\%$ = Percent of Total

*Tethers assumed to have failed on date of inspection.

1. New tethers (146 total - installed 5 June 79)
2. Types A & B (36 total - installed 14 Dec 78)
3. Original tethers (9 total after refurbishment - installed 12 Apr 78)

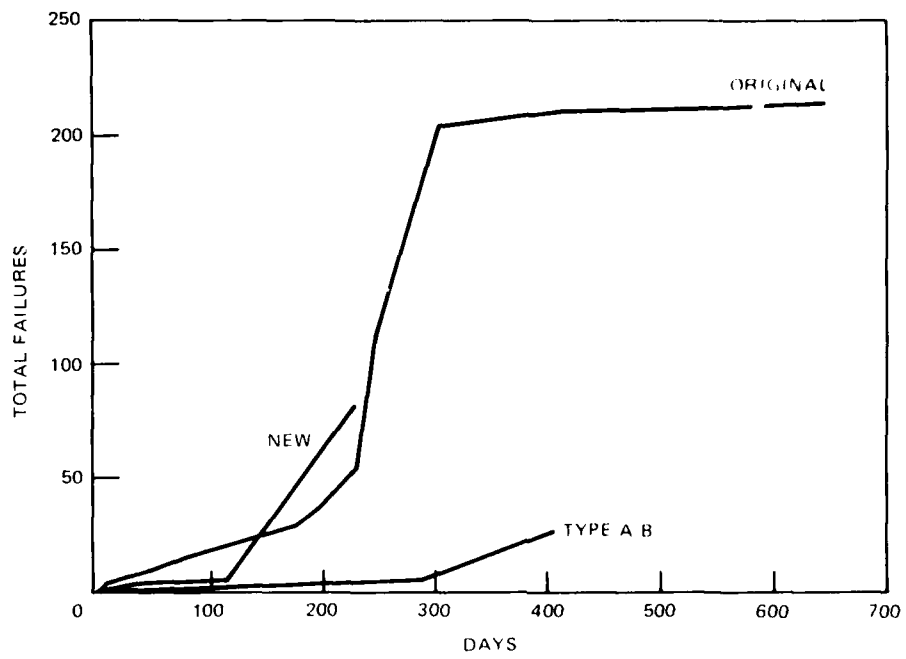

Figure 28. Tether failures (total) vs life cycle.

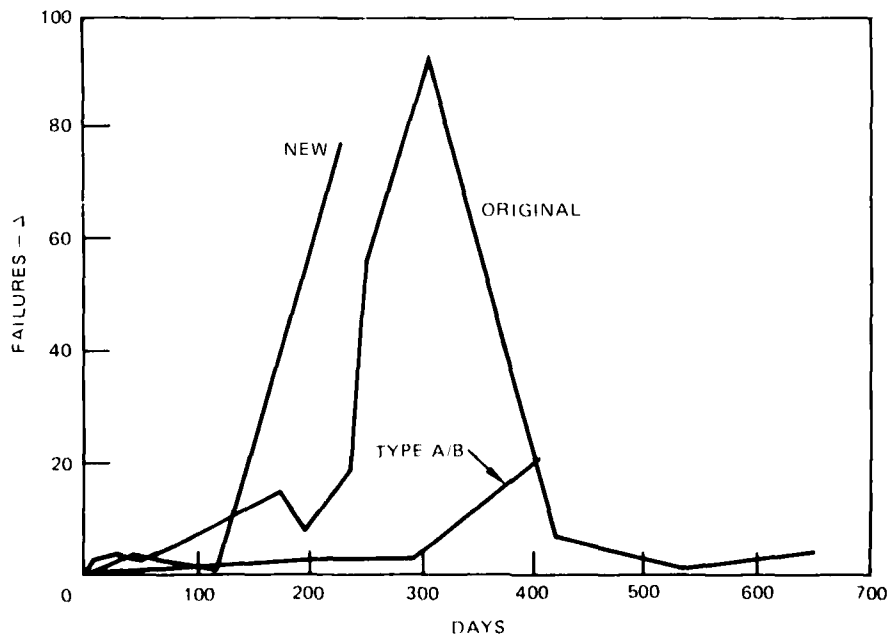

Figure 29. Tether failures (incremental) vs life cycle.

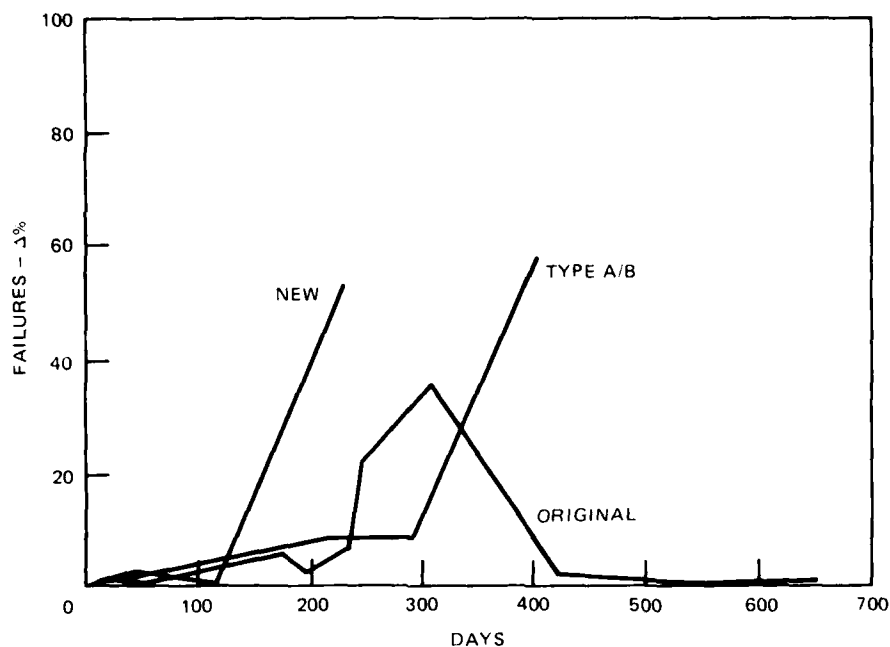

Figure 30. Failure percentage (incremental) vs life cycle.

The mean time to failure for the three types of tethers is presented in table 3.

Table 3. Mean time to failure of tethers.

Tether Type	Mean Time to Failure	Standard Deviation
Original Design	264.64 days	94.52 days
Modified (Types A & B)	371.00 days	65.83 days
New Design (Type B)	220.35 days	42.38 days

Calculations are given in appendix E. It must be noted that the TFB refurbishment utilized floats that were recovered from the beach. These did not meet the original design specifications because of water absorption (this caused an increase in density and abnormal float motion) or minor damage to components (in a few cases, tires or concrete were missing). The Type A/B tether replacement of December 1978 was performed on undamaged floats. Storm conditions were much more severe during the '79-'80 winter (November to February) than during the previous year. These factors account for the apparent discrepancies in the mean time to failure calculations. The lower value for new tethers (Type B) is not completely valid since the same style tether assembly installed earlier in the test program under different conditions had an average life of 371 days vs 220 days.

The locations of missing floats noted during inspection dives are recorded in appendix E. Ballast 1 was leeward; the longitudinal dimension was approximately parallel to the beach during most of the Ocean Experiment. Initially, the majority of tether failures occurred

on this unit. After October 1978, the number of missing floats was more evenly distributed between both modules. The 14 December data sheet (appendix F) illustrates the location of newly installed A/B type replacement tethers. The refurbished configuration (178 floats) of 5 June 1979 included 9 original tethers as indicated.

TFB OCEAN MODEL REFURBISHMENT

Between 29 May and 5 June 1979, the TFB Ocean Model was refurbished to 70% of its original configuration. Divers added 146 floats to the remaining 32, using rope pullers and lift bags. Rows 1, 13, 14, 15 and 16 were left vacant on ballast 1, as were rows 1, 14, 15 and 16 on ballast 2. This produced a symmetric breakwater consisting of 178 floats arranged in 16 columns as shown in figure 31.

The original intent was to remove the old termination boots from tether sockets on the ballast and insert the modified assemblies (Type B). However, due to a small expansion of the molded polyurethane within the socket, it was necessary to employ a hydraulic jack to remove the boot. This proved to be very time consuming. In order to conserve diver bottom time, new bolt-on type tether sockets (figure 32) were fabricated and attached to the frame adjacent to the original welded sockets (figure 33). Four-foot center-to-center spacing of the floats was maintained.

The refurbishment exercise demonstrated the ability of divers to perform routine maintenance and replacement of components in the open ocean. This capability is essential for long term TFB deployment.

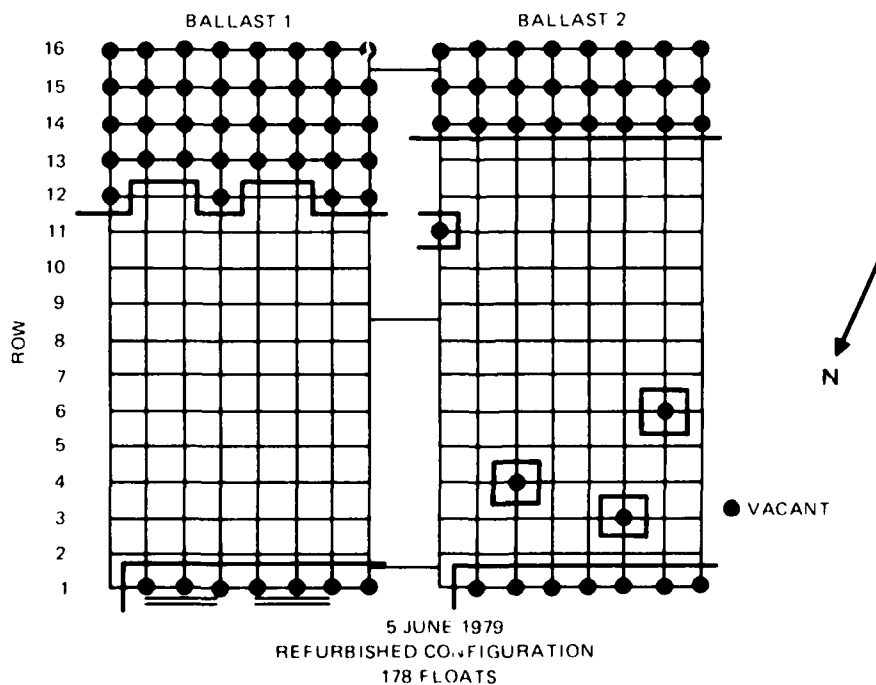

Figure 31. Refurbished TFB configuration

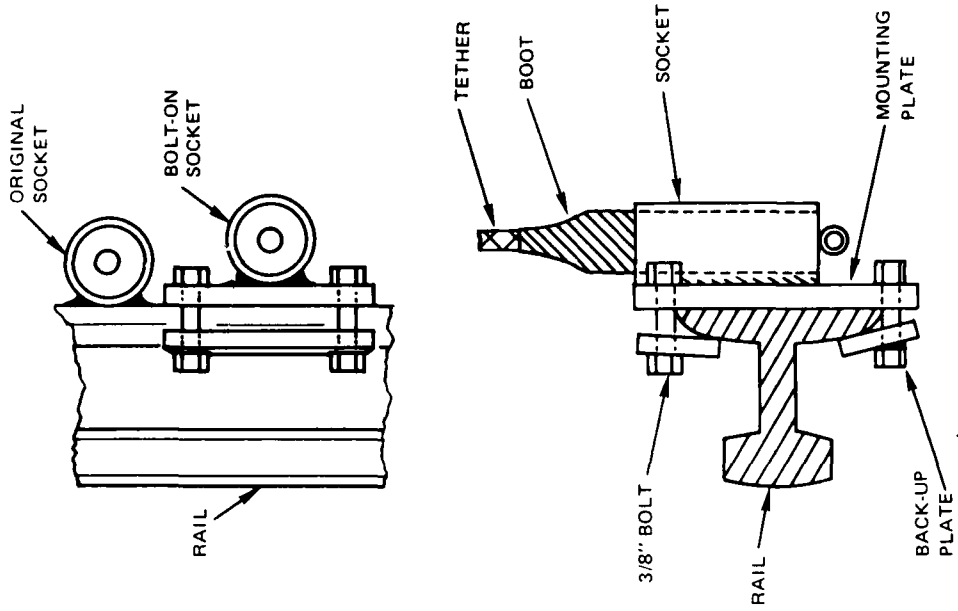

Figure 33. Attachment of bolt-on tether socket.



Figure 32. Bolt-on tether socket.

SYSTEM PERFORMANCE

A secondary goal of the TFB Ocean Experiment was a validation of system performance, ie, how closely does wave height reduction achieved with full scale prototype hardware compare with refined computer model predictions.

Scripps Institution of Oceanography was contracted to monitor the direction and spectral content of the local incident wave climate at the Imperial Beach test site, and compare wave attenuation with analytical predictions of performance. This effort is discussed in detail in reference 2.

Shore-based electronics and a telephone link were installed at the Naval Communication Station, Imperial Beach, during November–December 1978 (4 months after the relocation experiment). Wave gage installation was not scheduled until early 1979. In the meantime, multiple tether failures dictated refurbishment of the TFB before meaningful data could be collected. This was completed in June 1979. In conjunction with this task, Scripps personnel installed two wave measuring transducers and their associated cables adjacent to the breakwater. One sensor was located about 20 feet outboard of ballast 2; the other was mounted on the inboard side of ballast 1 (figure 34). Data were to be recorded every 10 hours throughout the remainder of the experiment.

-
2. Final Report, Oceanographic Research in Support of the Tethered Float Breakwater Ocean Experiment, RJ Seymour, 1 Nov. 1978 to 29 Feb. 1980.

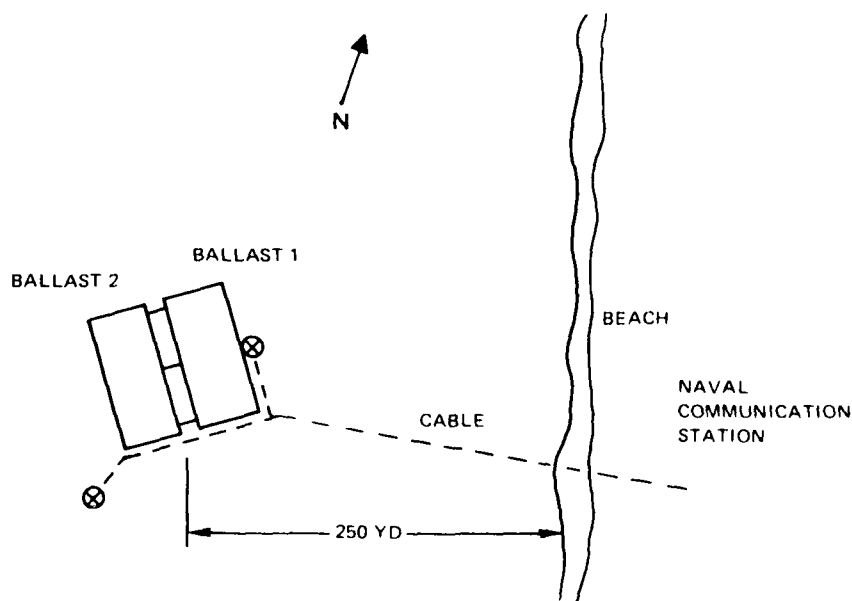

Figure 34. Location of wave gages.

At the end of July 1979, problems were encountered with the signal from the inner wave gage. During August, the transducer was changed, a possible cable problem diagnosed, and the land portion of the signal cable replaced by a shielded cable designed to eliminate crosstalk between the two transducer signals. The connection on the outer wave gage failed during this period, and was replaced. In mid-September, the intermittent cable problem with the inner gage required field splicing of the transducer. At the end of the month, however, signals from both sensors abruptly ceased. Inclement weather and other problems prevented a complete inspection of the instrumentation system until mid-November. Both cables were found to be cut, most probably by a dragging anchor. New cables were not delivered and terminated until mid-January 1980. By this time, the breakwater had deteriorated to the extent that meaningful data could no longer be gathered. The new cable was not installed.

Data were obtained from the Imperial Beach installation between 11 and 24 September 1979. Wave conditions during this period were generally less than optimum. Instrumentation problems and delays in initiating data collection prevented making many measurements during conditions approaching the design wave period of 8 seconds. Most recorded runs were at peak periods much greater than ideal; however, several runs on 19 and 20 September were reasonable approximations of the design spectrum. A preliminary data analysis is presented in appendix G.

The original computer model was modified to reflect the configuration of the refurbished breakwater (178 floats arranged in 16 rows vs 256 floats), change in float density (0.65 vs 0.56 due to water absorption), and increased depth of the float centerline due to scouring of the ballast.

The average measured energy transmission ratio (ETR) for 38 data runs was 89.9 percent, while the predicted ETR was 93.1 percent. This corresponds to a 10-percent energy reduction. The average measured height transmission ratio (HTR) for all runs was 94.8 percent; the predicted HTR was 96.5 percent. A 5-percent reduction in the incident wave height resulted. Table 4 shows ETR and HTR for 7 data runs made at low tide and 7 runs at high tide. There was little change in system performance between these water conditions. This may be due in part to the fact that, for most cases, the incident wave spectra had a much lower peak frequency than the design value, and thus the relative velocity spectra suffered little attenuation with depth. Typical TFB performance curves and tabulated data are included in appendix H for 19-21 September when the peak wave period approximated design conditions. The average measured ETR for this period was 87.6 percent; the average HTR was 93.6 percent.

Measured TFB performance was closely approximated by the computer model over a broad range of conditions. This data base reinforces the confidence in a Tethered Float Breakwater system to reduce wave height and the ability of a computer model to accurately predict its performance level.

Table 4. Average energy and height transmission ratios.

Condition	Predicted		Measured	
	ETR	HTR	ETR	HTR
All (38 runs)	0.931	0.965	0.899	0.948
Low Tide (7 runs)	0.916	0.961	0.882	0.939
High Tide (7 runs)	0.943	0.971	0.902	0.949

Range of values				
Condition	Predicted		Measured	
	ETR	HTR	ETR	HTR
All	0.864-0.974	0.929-0.987	0.774-0.985	0.880-0.993
Low Tide	0.878-0.960	0.937-0.980	0.830-0.939	0.911-0.969
High Tide	0.924-0.958	0.961-0.979	0.774-0.985	0.880-0.993

TERMINATION OF THE OCEAN EXPERIMENT

During January 1980, it became increasingly evident that a viable experiment could no longer be conducted due to the large number of floats that had washed ashore, and the inactive status of the wave measuring equipment. Following the January hardware inspection, the general condition of the TFB and instrumentation was discussed with Scripps and the sponsor. It was decided to remove the remaining floats and terminate the Ocean Experiment. This was accomplished on 11 February 1980. The ballast assemblies remain in place, and will be used for continued evaluation of other float/tether systems.

RELATED TFB EXPERIMENTS

The Japan Marine Science and Technology Center (JAMSTEC) is presently involved in a TFB program similar to the Ocean Experiment. Their primary concern is the protection of marine fishery assets and associated equipment.

In August 1979, JAMSTEC installed full-scale prototype TFB hardware at Yura, Japan. It consisted of 105 floats arranged on five ballast frames, each with a 7 x 3 float configuration. The bottom resting system was at a nominal depth of 6 meters. The tops of the floats were 20 cm to 1 m below the surface. This variation was caused by the steep bottom slope at the test site. The tide range was only 20-30 cm. Limited fetch waves with periods of 6-7 seconds dominated the area.

Floats (0.6 meter dia. x 1.0 meter tall; specific gravity 0.4) were constructed from used tires and plastic buoyancy material (foam). Plaited rope tethers (24 mm dia. x 5 meters

long) were used for float attachment to steel and concrete ballast sections. In most cases, the line was shackled to padeyes on the ballast assembly; however, a few units incorporated a flexible plastic cover (similar to the Ocean Model's molded polyurethane boot) to distribute bending stresses. The cover was not bonded to the tether, and subsequently had a tendency to slide up the line. Seven rows of floats produced a wave height transmission ratio of 63 percent.

The Japanese also experienced tether failures during periods of high wave activity. Some occurred at the lower cover or shackle attachment, and others 30 cm - 50 cm below the float due to entanglement with adjacent tethers. A preliminary report is included in reference 2.

JAMSTEC views TFB as a very promising concept, and plans to continue hardware development which will eventually lead to actual applications.

RECOMMENDATIONS

Corrosion of the ballast assemblies must be continuously inhibited. The sacrificial zinc anodes should be replaced at 8 to 10 month intervals to provide the necessary level of protection for long term deployment.

The deballasting system could be modified to provide better control of the assembly. An odd number of tanks would permit a more satisfactory adjustment of trim during towing or relocation operations. Since tanks can be separately vented through standpipes, individual valves (vs pipe caps) at these locations would provide for easier operation. A manifold, consisting of two-inch pipe, individual tank valves and a single air connection, could interconnect the ballast tanks at each end of the assembly.

In future TFB construction, it is recommended that floats be molded from polyolefin-based thermosetting plastic (similar to the TFB Bay Model floats) to reduce weight, simplify handling procedures, and increase reliability in an open ocean environment.

Tether assemblies should be further modified to simplify on-site replacement and increase their life expectancy. A decrease of 0.15 inches in the molded diameter of the boot will permit a damaged unit to be easily removed from the tether socket without affecting its performance. A synthetic line with a higher breaking strength will reduce the failure possibility due to nonuniform axial loading. It is recommended that the present material, 3/8-inch-dia. Samson VI S (4,000-lb breaking strength), be replaced with 1/2-inch dia. Samson Blue Streak (7,000-lb breaking strength).

An alternative to the present method of tether termination at the ballast is the use of a ball and socket assembly similar to that illustrated in figures 35a and 35b. The ball is cast from phenolic resin, and the socket machined from ultra-high molecular weight (UHMW) polyethylene to provide corrosion and abrasion resistance, and low friction characteristics. This design was successfully tested in 1976-1977, but under different conditions (water depth was 40 feet; a 25-foot-long by 1-inch-dia. tether was used for a float of 3,000-lb buoyancy). Unlike the molded boot, the ball is not rigidly attached to the frame; it is free to



Figure 35(a). Ball and socket tether termination — disassembled.



Figure 35(b). Ball and socket tether termination — assembled.

rotate in any plane. Thus, the termination is not subjected to bending, but only to axial loads. Provision of a lubricated pivotal attachment for the tether assembly should increase the life expectancy of the system.

In the fall of 1980, twelve molded float prototypes of the design previously discussed will be installed on a ballast section at the Imperial Beach test site. The following methods of tether termination will be used: ball and socket assembly - 3 units, Ocean Model assembly

3 units, Ocean Model assembly with tapered boot - 3 units, and pressure pad assembly (modified TFB Bay Model "Living Hinge") - 3 units. Samson Blue Streak (1.2-inch dia.) will be used in the tether assemblies. The float/tether systems will be monitored and evaluated over several months. Results will be compared with those of the original Ocean Experiment hardware.

CONCLUSIONS

The Tethered Float Breakwater Ocean Experiment successfully demonstrated the feasibility of a portable breakwater system that could be towed to an operational site, installed with a minimum of support equipment, and later removed or relocated. The ability to perform routine maintenance and replacement of components (floats and tethers) in the open ocean was also shown.

The design and fabrication of TFB hardware that can survive in an unpredictable marine environment will remain a challenge. The results of the Ocean Experiment indicate that the present ballast assembly can withstand loads imposed during installation and relocation, and will not deteriorate during typical deployment periods. The tire floats are satisfactory for one-time usage or short-term installations. A molded configuration has been recommended, however. Although tether terminations are more reliable than they were a few years ago, further development is required to reach the original design goal of a five-year life expectancy.

The program verified the wave attenuation capability of a full-scale bottom resting system (even though data were limited), and also the ability of the computer model to predict this performance over a broad range of conditions. Larger breakwaters, containing many more rows of floats, can be designed with confidence in their ability to reduce wave height.

It was discovered that a TFB can provide an otherwise barren area with an artificial habitat for marine flora and fauna. Sea life is attracted to this type of installation in a relatively short period. This is an important consideration for potential users engaged in various forms of aquaculture and for marine fisheries.

REFERENCES

1. NOSC TR 378, Engineering Report: Tethered Float Breakwater Near-Shore Ocean Model, J Clinkenbeard, Sept. 1978.
2. Final Report, Oceanographic Research in Support of the Tethered Float Breakwater Ocean Experiment, R.J. Seymour, 1 Nov. 1978 to 29 Feb. 1980.

APPENDIX A
MARINE FOULING

APPENDIX A
MARINE FOULING

20 April 1978	Algae starting to grow on breakwater.
11 May	Algae 1-2 inches long on tethers, and 1/4 inch long on ballast and floats. Dense barnacle growth on boots (unit no. 2).
1 June	Same conditions as 11 May.
25 October	Algae 1/2-1 inch long and hydroids on ballast no. 2. Tethers (unit no. 2) covered with hydroids and algae 2-4 inches long; tethers on unit no. 1 clean. Lobster, crab, fish attracted to ballast.
27 September 1979	Density and type of marine growth is the same on both modules. The size remains constant.
22 January 1980	Algae colony decreased in size (1/2-1 inch long) and area covered. Large quantities of kelp tangled in tethers.

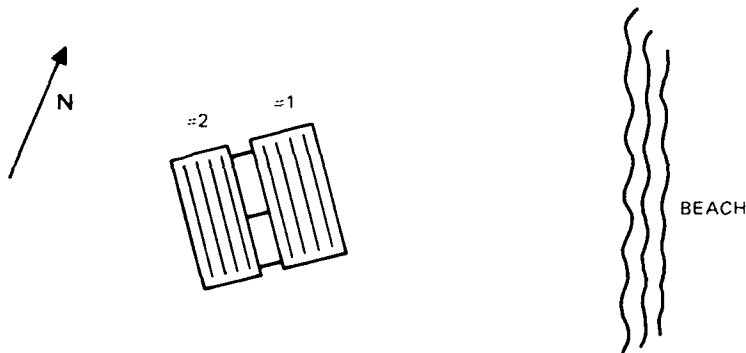

Figure A-1. TFB orientation (August 1978).

APPENDIX B
SETTLING OF BALLAST DUE TO SCOURING

APPENDIX B

SETTLING OF BALLAST DUE TO SCOURING

12 April 1978 Installation of Ocean Model (tanks perpendicular to beach)
 20 April Bottom of ballast 18-20 inches below normal seafloor; lower rails partially buried.

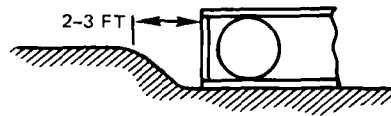

11 May Same depth but more pronounced.

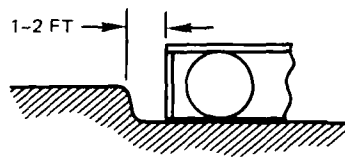

1 June Ballasts 24 inches below seafloor.

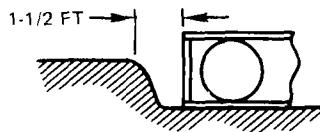

14 June 90 degree rotation experiment (tanks parallel to beach)

29 June Ballast starting to settle due to scouring.

2 August Relocation experiment (tanks parallel to beach)

5 October Ballast scoured in 18 inches.

25 October Module no. 1 (leeward) scoured in 24 inches; module no. 2 scoured in 36 inches. Tank no. 8 was 3/4 buried on south half.

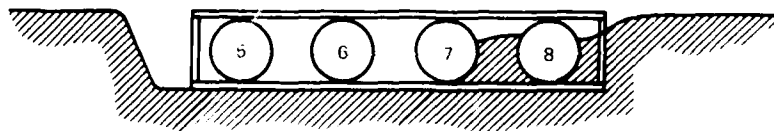

30 November Ballast tank no. 8 no longer buried.

13 February 1979 Ballasts settled 30-36 inches below seafloor. Tank no. 3 25% buried over a 5 foot length; tank no. 4 50% buried over same distance.

27 September Ballasts scoured in 18-24 inches.

22 January 1980

Ballast scoured in 30-36 inches.

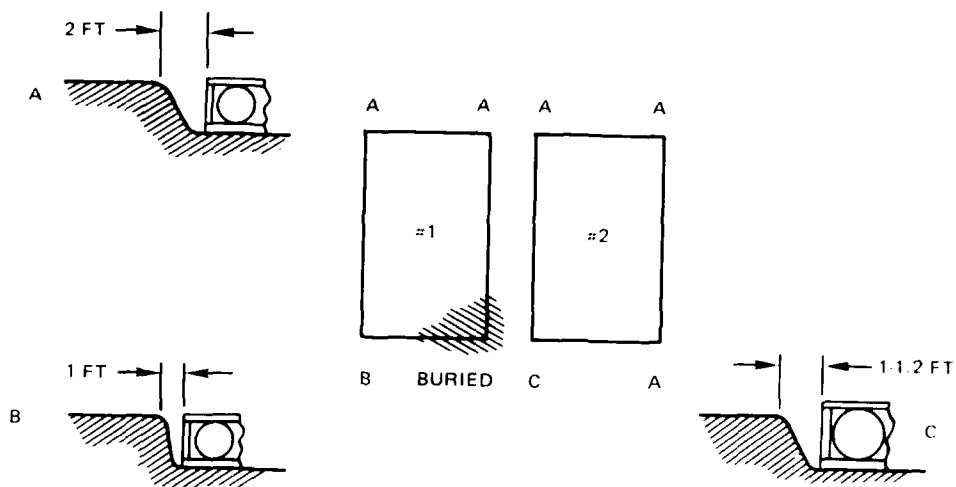

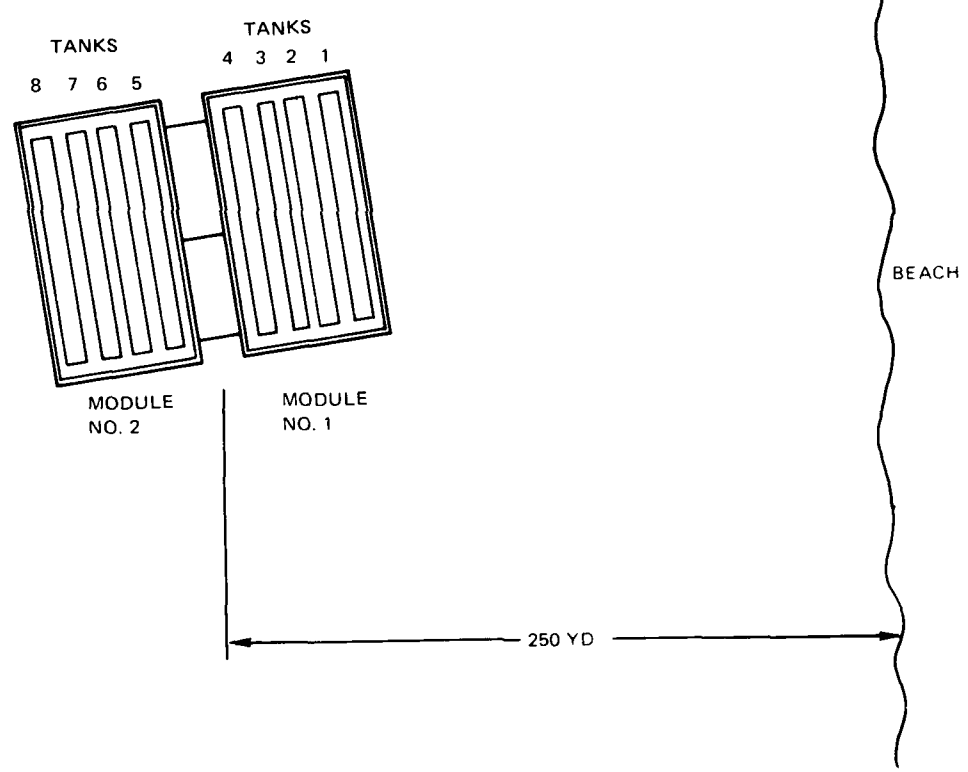
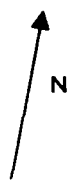

Figure B-1. Ballast tank configuration (August 1978).

APPENDIX C
WEIGHTS OF RECOVERED FLOATS

APPENDIX C

WEIGHTS OF RECOVERED FLOATS

Tires Missing	Foam	Concrete	Condition	Weight	Date
0 of 6	100%	100%	wet	581	10/12/78
0 of 5	100%	100%	wet	572	
0 of 5	100%	100%	wet	520	
0 of 5	100%	100%	wet	515	
0 of 6	95%	100%	wet	534	
0 of 5	100%	100%	wet	515	
0 of 6	100%	100%	wet	557	
3 of 6	50%	0%	wet	186	
2 of 6	60%	50%	wet	333	
0 of 5	90%	100%	wet	627	
0 of 5	75%	100%	wet	538	
0 of 5	90%	100%	wet	618	
0 of 5	90%	100%	wet	557	
0 of 5	100%	100%	wet	657	11/7/78
0 of 5	100%	100%	wet	686*	
			* 686 lb - 515 <hr/> 171 lb absorbed water		

Original Displacement: 920 lb

Original Weight: 515 lb

Original Buoyancy: 405 lb

APPENDIX D
REPORT OF FAILURE ANALYSIS

Lane Instrument Company

1548 FAYETTE ST., EL CAJON, CA 92020 • PHONE 714-448-8783 OR 448-8924

Customer: Naval Ocean Systems Center
271 Catalina Blvd.
San Diego, CA 92152

Contract Number: N66001-79-M-1746

Laboratory Number: 1165

Date Reported: 22 March 1979

Subject: Failure Analysis, P/N 1065-3/8

REPORT OF FAILURE ANALYSIS

SUMMARY

Approximately 95% of the tether assemblies, P/N 1065-3/8, produced under contract number N66001-77-C-0229 have failed in a common mode after 10 months of operation at Imperial Beach. The failure mode is identified with normal axial load cycling causing abrasion of filaments at the buried end of the lower splice. The abrasive condition is probably created due to entrapment of solid particulate matter within the line core at the point of failure. Impregnation and encapsulation of the line in the failure location with a low modulus elastomer was tested and is proposed as a corrective action to prevent recurrence of this type of failure.

FAILURE DESCRIPTION

The characteristic failure occurs at the buried end of the lower splice. This location is approximately 1/2 inch above the top of the boot as indicated in figure no. 1. The fiber ends of the line at the point of failure are of uniform length indicating that the failure occurs catastrophically. The line above the boot is impregnated but not encapsulated with elastomer at this point. The line, at the point of failure changes from the equivalent of a double braid to a single braid configuration.

DISCUSSION

The design of the tether assembly is such that under tensile loads of 150 to 800 pounds, the minimum bending radius at the termination is 8 inches. Initial qualification tests were conducted at NOSC under a constant load and in a rotating bending mode. The termination was submerged in sea water during the testing. These initial tests resulted in 3 to 11 million cycles before failure.

67
PRECEDING PAGE BLANK-NOT FILMED

Static load tests at a line displacement angle of 17 degrees introduces bending in the boot as follows:

Tensile Load	Minimum bending Radius	Location of Minimum Bending
800 lbs.	10 inches	3.5 in. from top
350 lbs.	9 inches	3 in. from top
100 lbs.	9 inches	2 in. from top

Observation of underwater vidio recordings made by NOSC indicates the oscillation at the boot is a slow back and forth motion with a rapid small amplitude oscillation occurring at approximately 1/3 cycle when the float is moving parallel to the wave direction. The bending appears to be confined to within the boot.

CAUSE OF FAILURE

The previous testing under constant loads indicates that the line bending at the point of failure is virtually zero, precluding flexural fatigue as a primary cause. The repeatability of the mode of failure assigns the cause to the transition of double braid to single braid at the buried splice end and above the top of the boot. While not verified by actual observation, this zone can entrap particulate matter which, under a cycling axial load could abraided the individual filaments in the line leading to the type of failure observed.

CORRECTIVE ACTION

When failures of the above type occurred in the fall of 1978, 20 tether assemblies were manufactured as P/N 1065-3/8-B under this same contract. The basic configuration of the tether was unchanged. However, a low modulus elastomer was used to encapsulate the line at the buried end of the splice, to prevent entrance of particulate matter into the line core and to minimize fiber-to-fiber abrasion during axially cycling loads. A number of these modified tether assemblies have been in operation a Imperial Beech without failure.

Respectfully submitted,

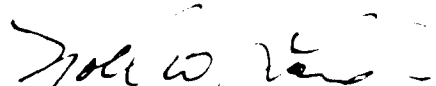
Noel W. Lane, Jr, FAIC

NWL/a

Lane Instrument Company

1548 Fayette St. EL CAJON, CA 92020 • PHONE 714-448-8783

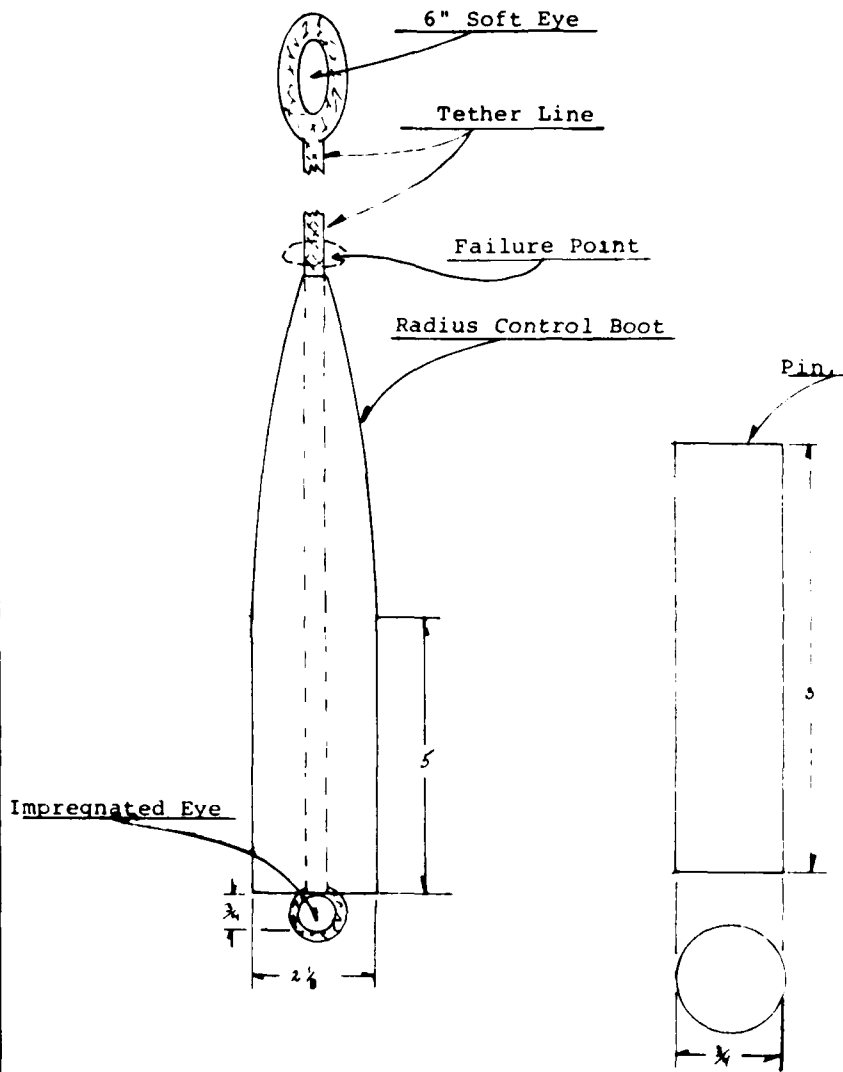

Figure Number 1

Part Number: P/N L1065-3/8	
Title: Tether Assembly	
Approved: <i>[Signature]</i>	of

APPENDIX E
MEAN TIME TO FAILURE AND STANDARD DEVIATION CALCULATIONS

APPENDIX E

MEAN TIME TO FAILURE AND STANDARD DEVIATION CALCULATIONS

Mean Time to Failure Based on failure of 216 (84.4%) original tethers between 12 Apr 1978 and 22 Jan 1980.

$$X = \frac{\sum_{j=1}^n X_j f_j}{N}$$

where

X = days to failure

f = no. failures

N = total failures (216)

n = no. samples (12)

$$X = \frac{1}{216} [8(3) + 29(4) + 50(3) + 78(5) + 176(15) + 196(8) + 232(18) + 246(56) + 307(92) + 420(7) + 534(1) + 651(4)]$$

X = 264.64 days

$$\text{Standard Deviation} = S = \left[\frac{\sum_{j=1}^n (X_j - \bar{X})^2 f_j}{N} \right]^{1/2}$$

$$S = \left\{ \frac{1}{216} [3(8 - 264.64)^2 + 4(29 - 264.64)^2 + 3(50 - 264.64)^2 + 5(78 - 264.64)^2 + 15(176 - 264.64)^2 + 8(196 - 264.64)^2 + 18(232 - 264.64)^2 + 56(246 - 264.64)^2 + 92(307 - 264.64)^2 + 7(420 - 264.64)^2 + 1(534 - 264.64)^2 + 4(651 - 264.64)^2] \right\}^{1/2}$$

S = 94.52 days

Mean Time to Failure Based on failure of 27 (75.0%) A/B type tethers between 14 Dec 1978 and 22 Jan 1980.

$$X = \frac{1}{27} [216(3) + 288(3) + 405(21)]$$

X = 371.00 days

PRECEDING PAGE BLANK-NOT FILLED

$$\text{Standard Deviation} = S = \left\{ \frac{1}{27} [3(216 - 371)^2 + 3(288 - 371)^2 + 21(405 - 371)^2] \right\}^{1/2}$$

$$S = 65.83 \text{ days}$$

Mean Time to Failure Based on failure of 82 (56.2%) new tethers between 5 June 1979 and 22 Jan 1980.

$$X = \frac{1}{82} [42(4) + 114(1) + 231(77)]$$

$$X = 220.35 \text{ days}$$

$$\text{Standard Deviation} = S = \left\{ \frac{1}{82} [4(42 - 220.35)^2 + 1(114 - 220.35)^2 + 77(231 - 220.35)^2] \right\}^{1/2}$$

$$S = 42.38 \text{ days}$$

APPENDIX F
LOCATION OF MISSING FLOATS

APPENDIX F

#1

#2

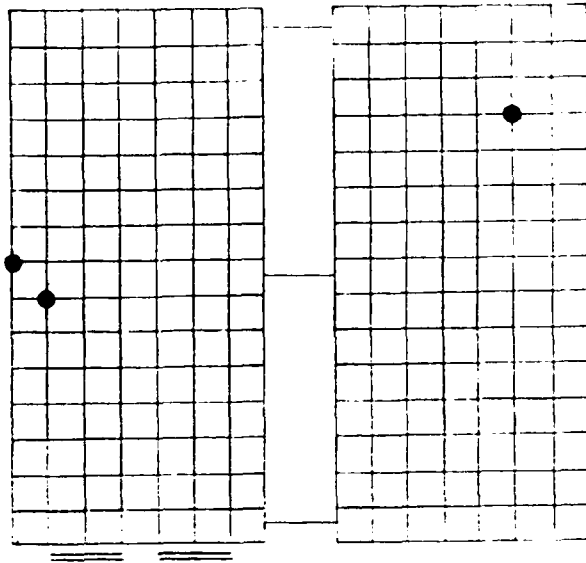

20 APRIL 1978
3 Floats Missing

1

2

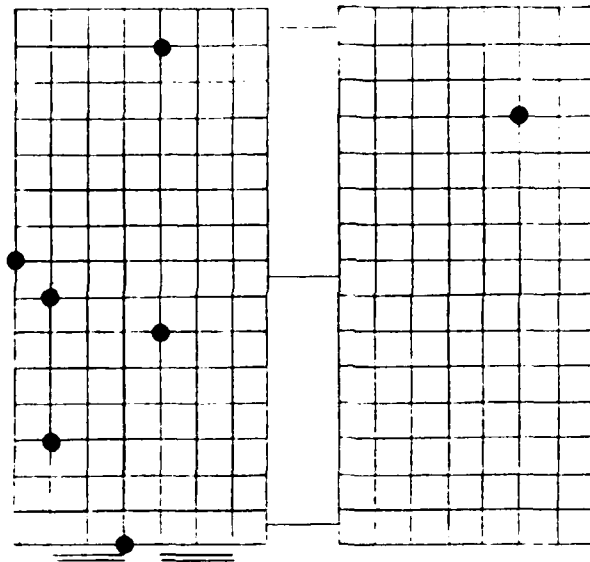

11 MAY 1978
7 Floats Missing

#1

#2

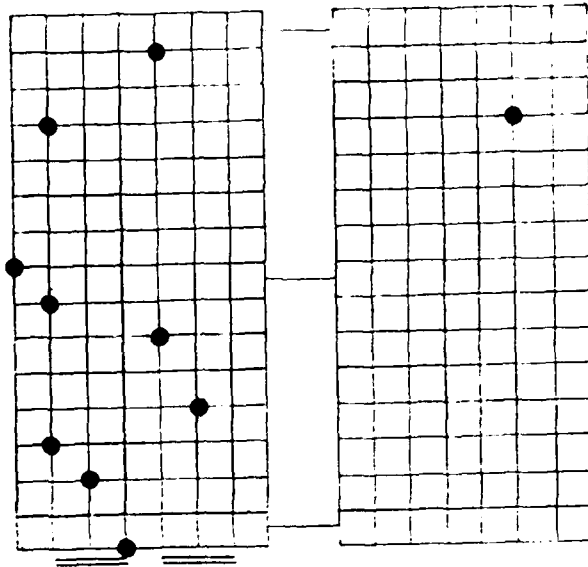

1 JUNE 1978
10 Floats Missing

#1

#2

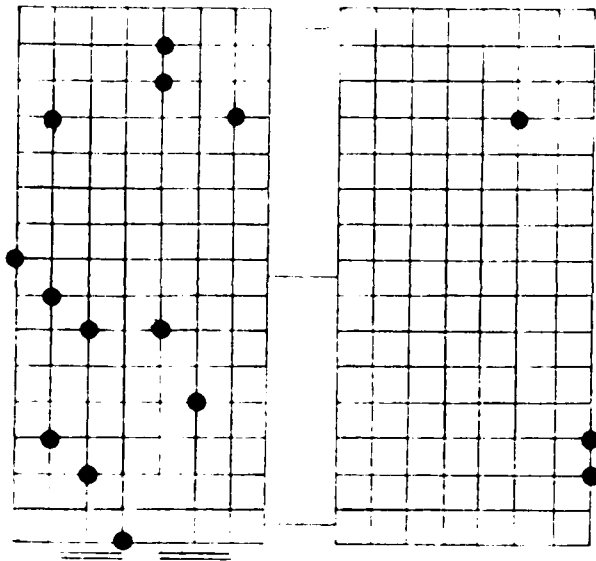

29 JUNE 1978
15 Floats Missing

#1

#2

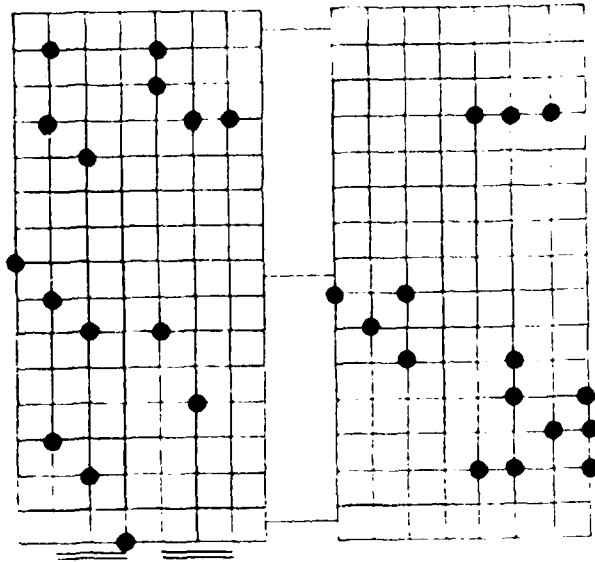

5 OCTOBER 1978
30 Floats Missing

#1

#2

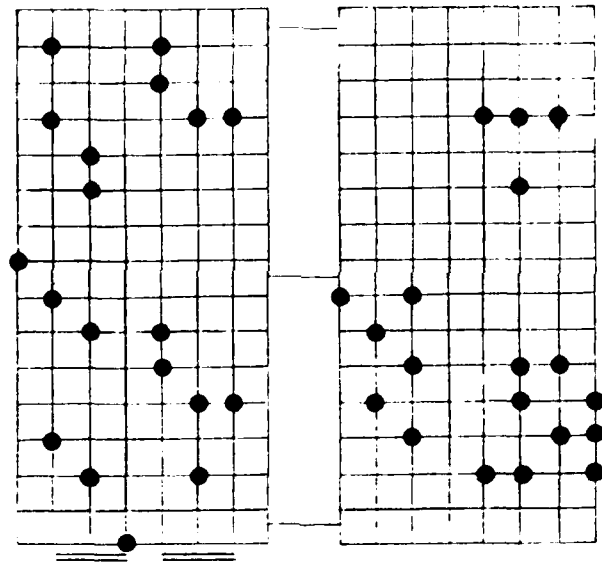

25 OCTOBER 1978
38 Floats Missing

#1

#2

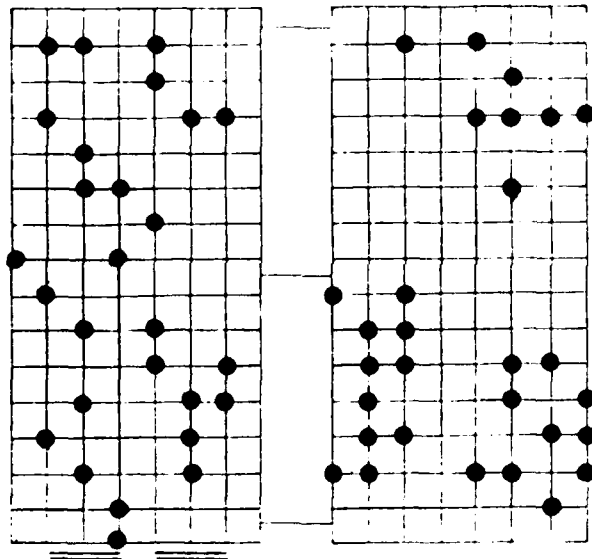

30 NOVEMBER 1978
56 Floats Missing

#1

#2

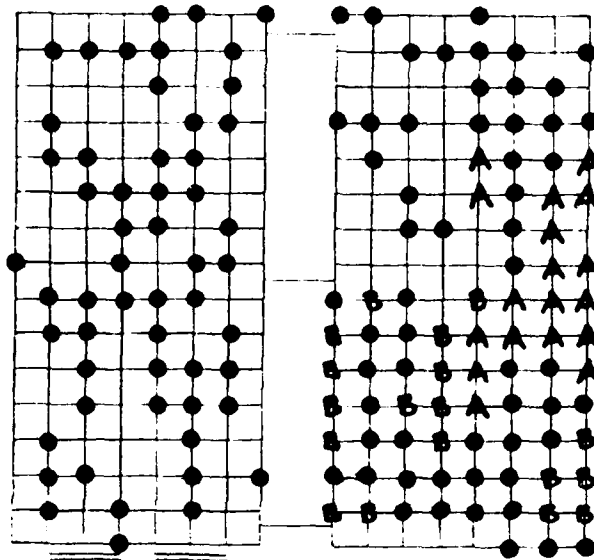

14 DECEMBER 1978
112 Floats Missing

Relocated 14-1 to 15-2
15-1 to 16-3
16-1 to 16-4

Replaced 36 tethers.

Type "A"-impregnate line 7 inches above
boot. 18 each

Type "B" - extend splice 6 inches; impregnate
line 7 inches above boot. 18 each

#1

#2

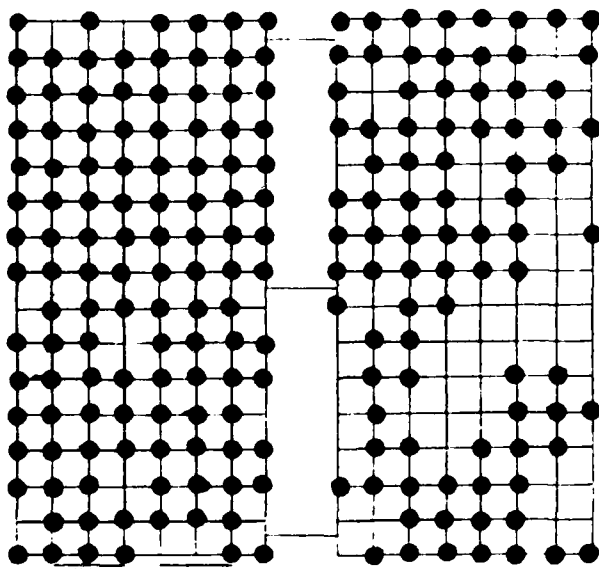

13 FEBRUARY 1979
204 Floats Missing

#1

#2

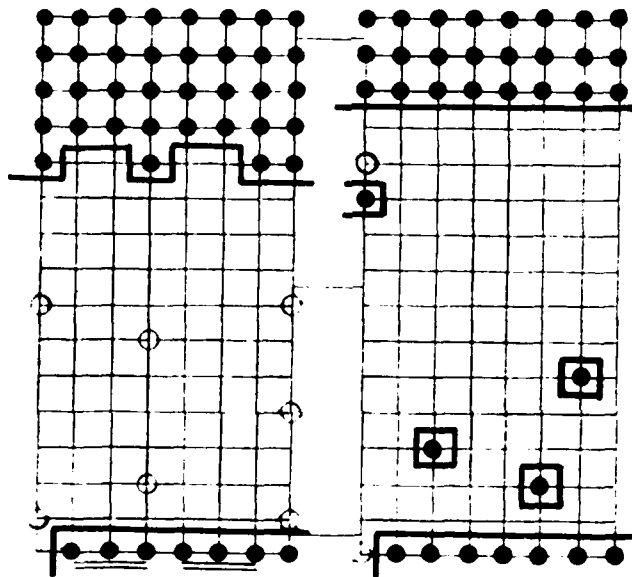

5 JUNE 1979
Refurbished Configuration
178 Floats

U original tethers

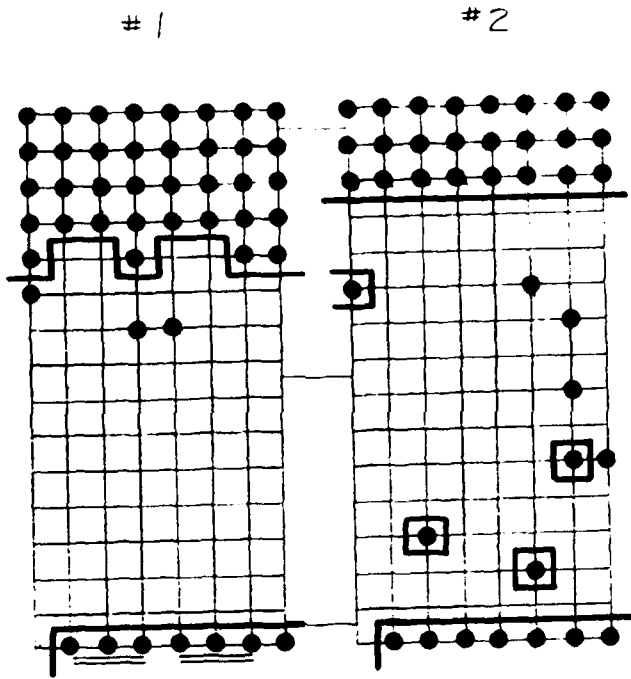

17 JULY 1979
7 Floats Missing

#1

#2

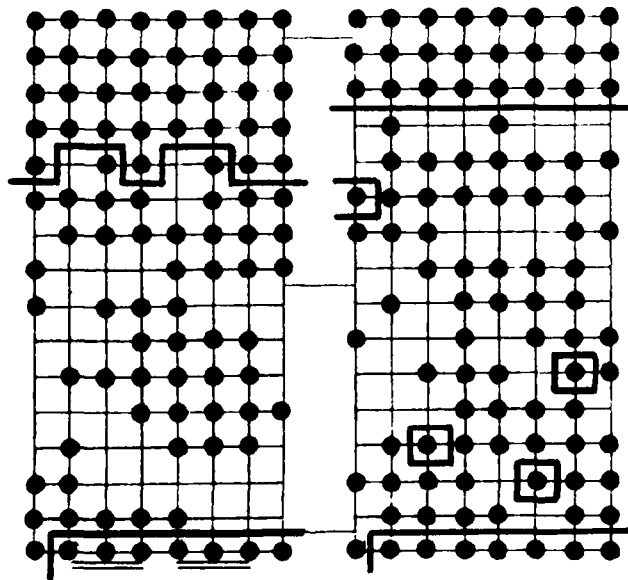

22 JANUARY 1980
114 Floats Missing

APPENDIX G

EXCERPTS FROM

SIO TECHNICAL NOTE 17, SILVER STRAND TETHERED FLOAT
BREAKWATER INTERIM REPORT
DAVID CASTEL, OCTOBER 1979

THE
TETHERED FLOAT
BREAKWATER
OCEAN
EXPERIMENT

Mail Code A022

UCSD

La Jolla

Ca. 92093

714-452-2561

TECHNICAL NOTE NO. 17

SILVER STRAND TETHERED FLOAT BREAKWATER

Interim Report

David Castel

Scripps Institution of Oceanography

OCTOBER 1979

INTRODUCTION

This interim report presents some of the initial results obtained from the full-scale tethered float breakwater experiment at Silver Strand Beach.

The report covers data collected between the dates of September 11 to September 24, 1979. Because of the limited range of the data set, the report does not attempt any comprehensive analysis of the data, rather performance charts of the TFB are presented along with theoretical predictions based on the existing wave climate. Analysis is reserved for the final report when a more complete and varied data set will exist.

PHYSICAL ARRANGEMENT OF THE EXPERIMENT

Two full-scale tethered float breakwater (TFB) modules, each measuring 18.3 m X 9.1 m, were deployed in the Silver Strand area of Imperial Beach. The two modules were set one behind the other (with respect to the beach) in 762 cm of water at MLLW so that the 18.3 m sides were parallel and adjacent to one another. The two units were separated by approximately 3 m so that the two modules formed a rectangle some 21.3 m X 18.3, the 18.3 m dimension being parallel to the beach. For a complete description of the design, construction, deployment and configuration, see a report by J. D. Clinkenbeard [1978]. This arrangement resulted in a TFB 16 rows deep by 12 rows wide. Table I describes the TFB parameters.

TABLE I	
cylindrical float diameter	127 cm
float height	63.5 cm
effective tether length	401.5 cm
float spacing	127 cm
number of rows	16
float specific gravity	0.65
water depth	762 cm MLLW
breakwater beam	1829 cm
breakwater length	2286 cm
depth to center line of float	360 cm at MLLW

Originally, the tether to ballast unit hinge was located about 122 cm above the bottom, however, with scouring, the ballast settled some 92 cm into the sandy bottom so that the bottom hinge is located 30 cm above the bottom. This condition increased the depth to g of the float by 92 cm over the design condition.

DATA COLLECTION

Simultaneous wave measurements of the incident wave field and the attenuated exiting waves were made by a pair of Gulon GS 163 pressure transducers. The gauges were mounted in a standard California Coastal Engineering Data Network bottom transducer mount and were held at an elevation of 122 cm above the bottom. Data were telemetered to a shore data acquisition station via two shielded and separate cables. At preset intervals, a dedicated mini-computer at the Scripps Institution of Oceanography lab would access the field data station and record the data on magnetic tape. Between September 11 and 14, data runs were taken every ten hours. This interval was changed on September 14 to an approximate 12-hour sequence to coincide with periods of low low tides. The interval was shortened to approximately six hours on September 17 to coincide with half tidal periods and remained that way until September 24. Each data set consisted of 1024 data points (one for each gauge) at a sampling frequency of 1 hz which gave a continuous data sampling period of 17.07 minutes.

Previous experimental TFB lab and field data, Seymour and Hanes [1979], have shown that some of the incident energy may be reflected from the TFB. This reflection requires that the gauge measuring the incident energy be so placed as not to record these reflections. The incident gauge was located approximately 2.75 m upward of the ballast and approximately 7.62 m to the south. The gauge measuring the attenuated waves was placed directly behind the last row and at the midpoint of the ballast.

WAVE CLIMATE

The 38 data runs collected over a two-week period exhibit the usual seasonal wave climate [CCEDN 1976, 1977] for Imperial Beach. The significant wave height ranged between 60 and 90 cm and the peak period was nominally centered at about 10 to 15 sec. The period is noted for the absence of any storm activity and for the presence (around September 17-21) of a Santa Ana wind (a condition typified by easterly winds which tend to knock down the higher frequency components). A tabulation of the incident wave climate appears in Appendix A.

RESULTS

Figure 1 shows an average, by frequency band, of the 38 data sets of the ratio of the calculated energy transmission ratio to the measured ETR. The two bracketing lines represent a 95 percent confidence limit on the calculation. The calculations were programmed to ignore frequency bands whose incident energy content was lower than a preset threshold value. This was done to eliminate noise considerations from the calculation. As Figure 1 shows, the predictive model very closely follows the actual energy measurements. This is particularly

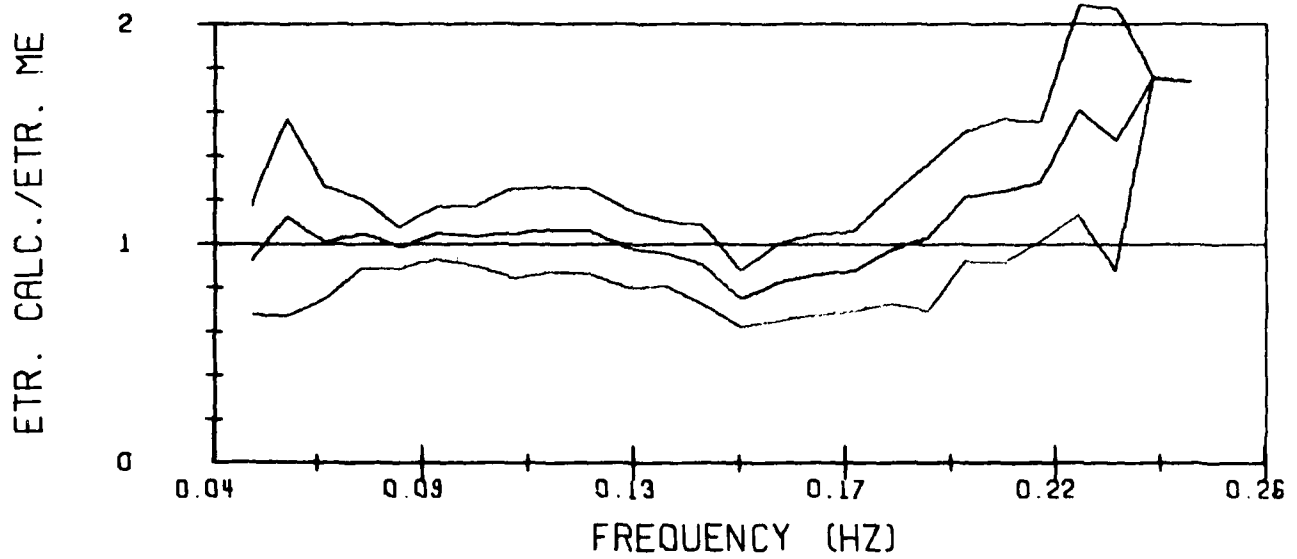

RATIO OF CALCULATED ETR
VS. MEASURED ETR
AS A FUNCTION OF FREQUENCY

95% confidence limits are shown.

FIGURE 1

so around the design frequency of 0.13 Hz. In the program's range that is of interest, i.e., for $0.0625 < f < 0.147$, the predicted ETR is within 3 percent of the measured ETR. The prediction deteriorates somewhat for the higher frequency but for the most part tends to underestimate breakwater performance. The design frequency of the TFB is calculated at 0.13 Hz and the design depth to the center line of the float was set at 239 cm. Both these important parameters were consistently outside the design specifications in the field experiment. A histogram of peak wave length frequency, Figure 2, shows that 76 percent of the time the peak frequency was significantly lower than the design frequency while in only 13 percent of the runs did the design frequency coincide with the peak frequency. Appendix B shows that for the most part the depth to center line of the float was almost 50 percent greater than the design depth. Ironically, the off design frequency condition tended to compensate for the excessive float submergence since the lower frequency waves suffer less attenuation with depth.

Figure 3 is a scatter plot of the overall energy transmission ratios, measured vs. predicted. A 45° regression line through the points shows that with the exception of a few cases the predictor does a reasonable job of estimating overall energy transmission ratios.

The average measured ETR for the 38 data runs was calculated at 90 percent while the predicted ETR was 90 percent for a ten percent energy reduction in the incident spectrum. At lower water conditions, the average for 16 runs was 89.4 percent ETR measured vs. 89.3 percent ETR predicted. Similarly, for the 22 higher water conditions, the measured ETR was 90.1 percent, while the calculated was 91.1 percent.

The data base of 38 runs needs to be significantly enlarged and seasonal variabilities must be introduced into the incident spectra for meaningful conclusions to be drawn; however, it did appear that to within a few percent the predictive model accurately forecasted breakwater performance. Examination of Figure 1 suggests that there might be some frequency dependence for the hydrodynamic coefficients of the form

$$C_D = f(f) \text{ and}$$

$$C_m = g(f)$$

which indicates a possible improvement in the piece-wise, frequency band prediction if a dynamic, empirical recursive process of adjustment, by frequency band, were to be applied to the model's drag calculations. Such a procedure will be attempted as the data base becomes more comprehensive.

PEAK FREQUENCY HISTOGRAM

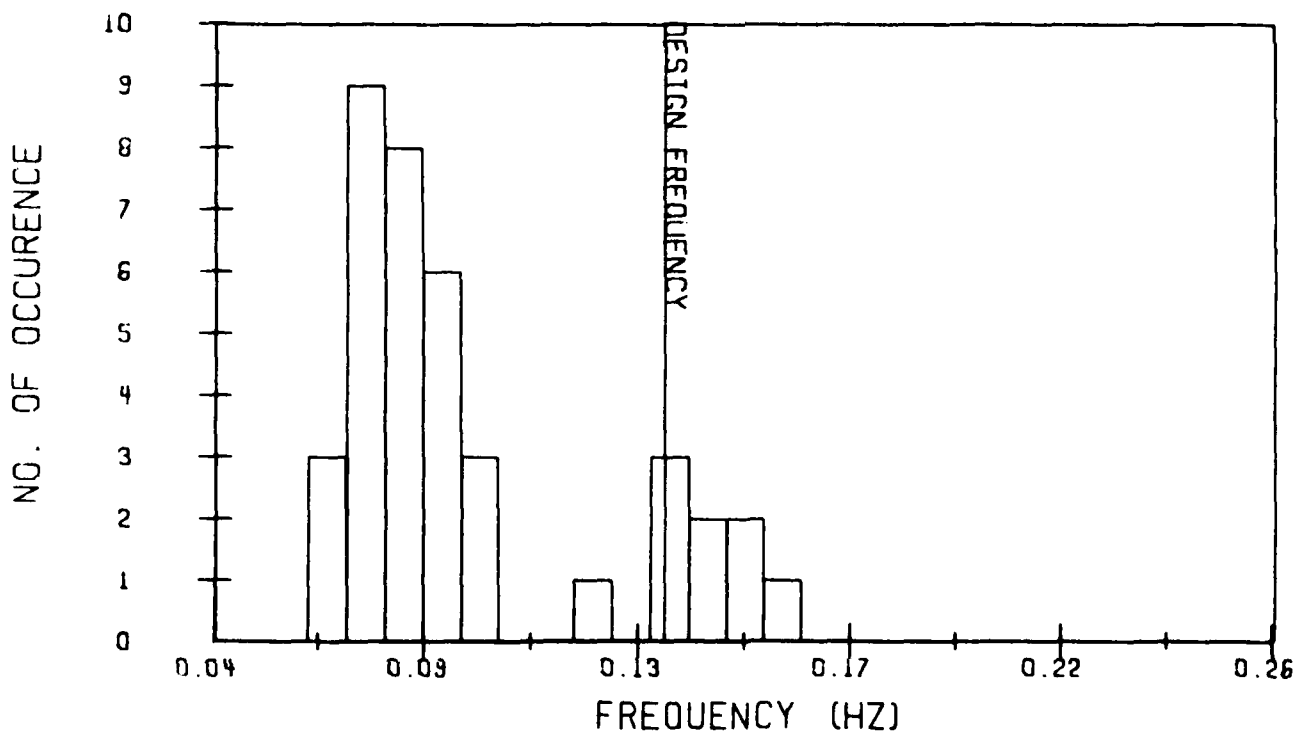
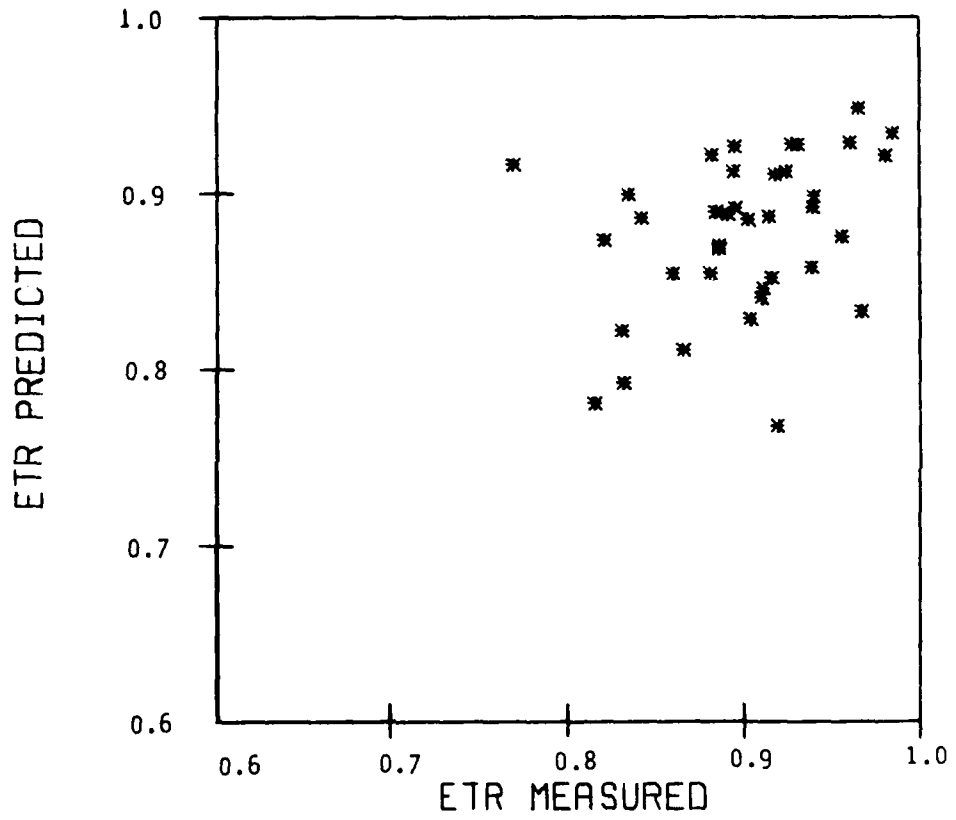

FIGURE 2



SCATTER PLOT OF OVERALL ENERGY TRANSMISSION RATIOS

FIGURE 3

APPENDIX H
TFB PERFORMANCE CURVES AND TABULATED DATA

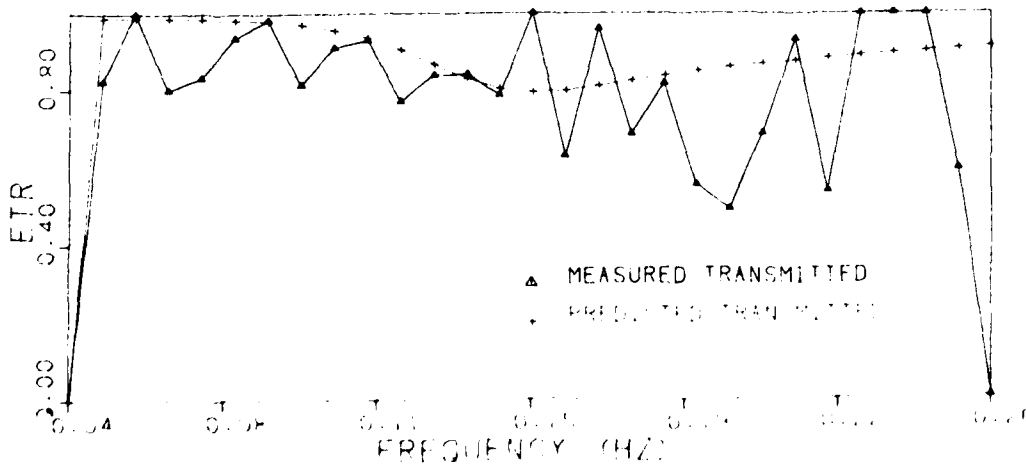
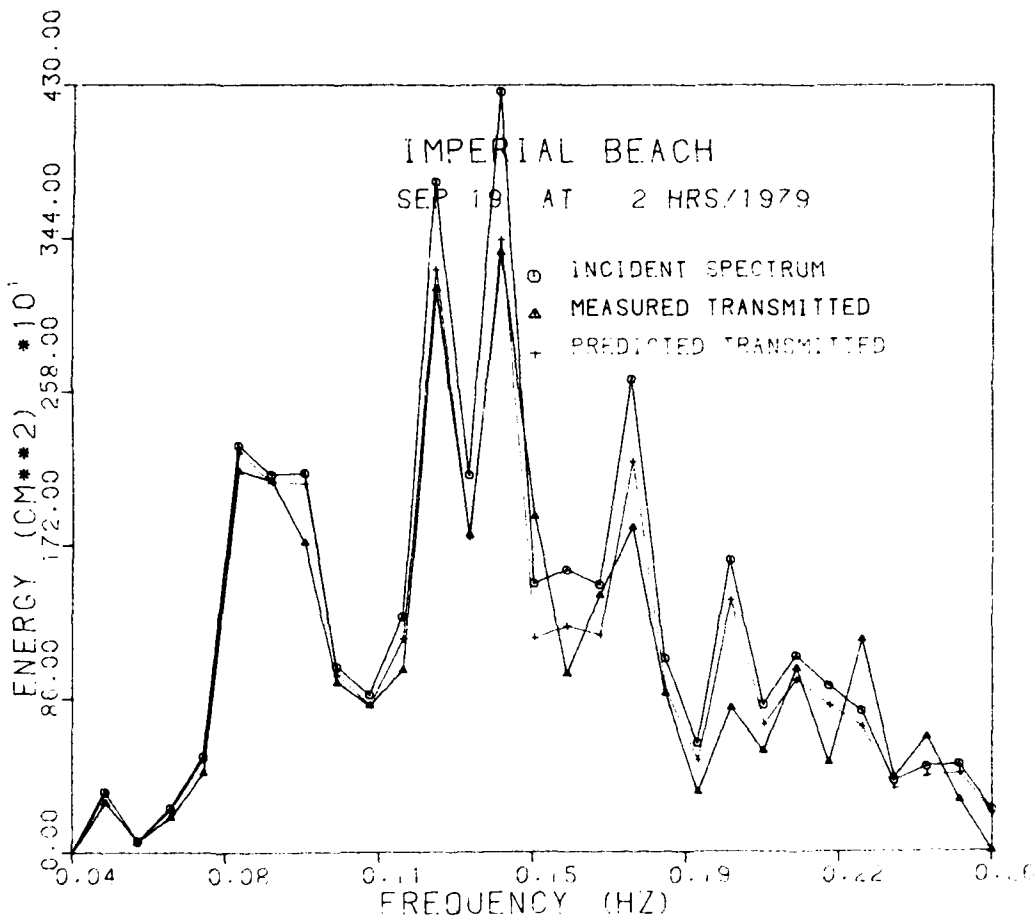

IMPERIAL BEACH TFB. SEPTEMBER 1979
RUN NO. 19

SEP 19 AT 2 HRS/1979

CYLINDRICAL FLOAT, HEIGHT = 127.00 CM.
FLOAT DIAMETER = 63.50 CM EFFECTIVE TETHER LENGTH = 401.5 CM
X-SECTIONAL AREA = 8064.5 CM. SQ. VOLUME = 402199.9 CC
FLOAT SPACING = 127.00 CM FLOAT DENSITY = 0.6500 GM/CC
DEPTH TO C.L. = 317.42 CM WATER DEPTH = 779.9 CM
DELTA F = 0.0078 NO. BANDS = 28
TETHERED FLOAT NATURAL FREQUENCY = 0.134
DEPTH OF WATER TO WAVELENGTH RATIO = 0.13406
CD = 1.000 CM = 0.550 DCD = 0.550

SIGNIFICANT WAVE HEIGHT, INCIDENT (CM) = 67.534
ACTUAL SIGNIFICANT WAVE HEIGHT, TRANSMITTED (CM) = 61.565
PREDICTED SIGNIFICANT WAVE HEIGHT, TRANSMITTED (CM) = 63.290

ACTUAL PERFORMANCE

ENERGY TRANSMISSION FACTOR = 0.831
HEIGHT TRANSMISSION FACTOR = 0.912

PERFORMANCE ESTIMATES

ENERGY TRANSMISSION FACTOR = 0.878
HEIGHT TRANSMISSION FACTOR = 0.937

NUMBER OF ROWS = 16

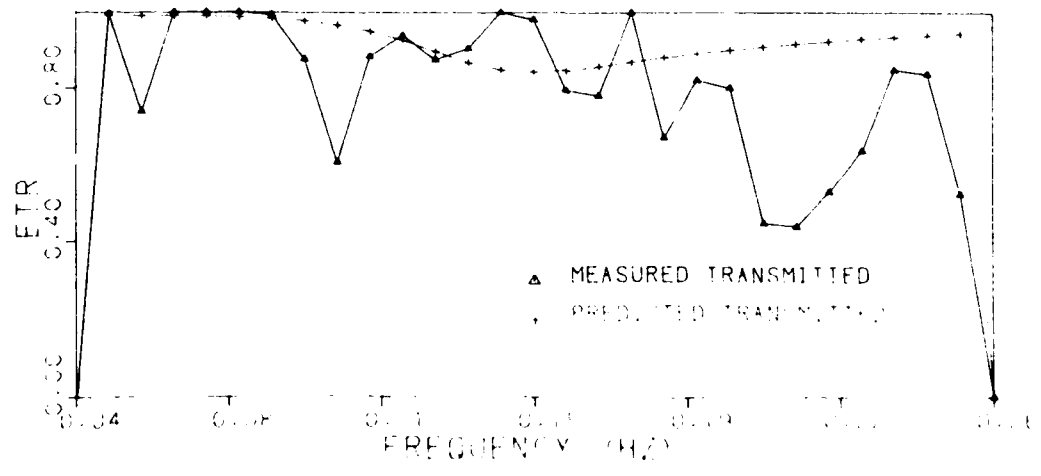
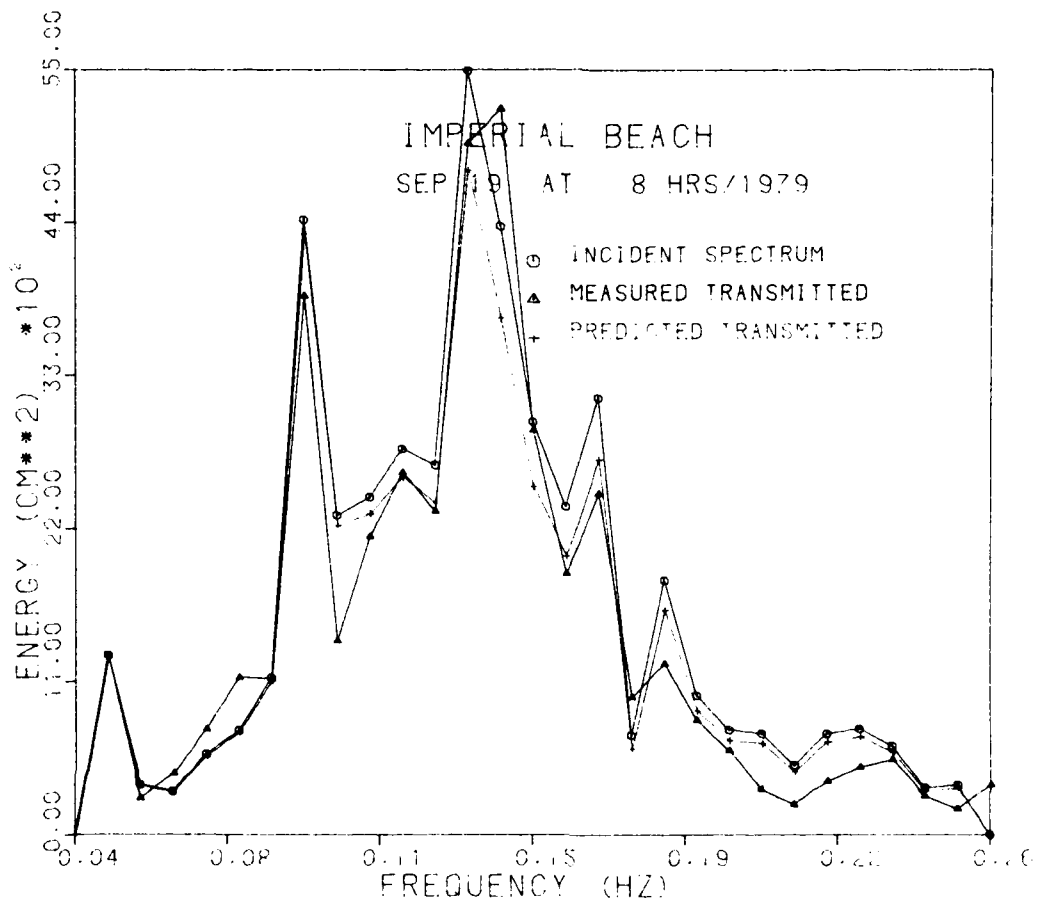

IMPERIAL BEACH TFB. SEPTEMBER 1979
RUN NO. 20

SEP 19 AT 8 HRS/1979

CYLINDRICAL FLOAT, HEIGHT = 127.00 CM.
FLOAT DIAMETER = 63.50 CM EFFECTIVE TETHER LENGTH = 401.5 CM
X-SECTIONAL AREA = 8064.5 CM. SQ. VOLUME = 402199.9 CC
FLOAT SPACING = 127.00 CM FLOAT DENSITY = 0.6500 GM/CC
DEPTH TO C.L. = 443.92 CM WATER DEPTH = 906.4 CM
DELTF = 0.0078 NO. BANDS = 28
TETHERED FLOAT NATURAL FREQUENCY = 0.134
DEPTH OF WATER TO WAVELENGTH RATIO = 0.13668
CD = 1.000 CM = 0.550 DCD = 0.550

SIGNIFICANT WAVE HEIGHT, INCIDENT (CM) = 74.058
ACTUAL SIGNIFICANT WAVE HEIGHT, TRANSMITTED (CM) = 70.669
PREDICTED SIGNIFICANT WAVE HEIGHT, TRANSMITTED (CM) = 70.940

ACTUAL PERFORMANCE

ENERGY TRANSMISSION FACTOR = 0.911
HEIGHT TRANSMISSION FACTOR = 0.954

PERFORMANCE ESTIMATES

ENERGY TRANSMISSION FACTOR = 0.918
HEIGHT TRANSMISSION FACTOR = 0.958

NUMBER OF ROWS = 16

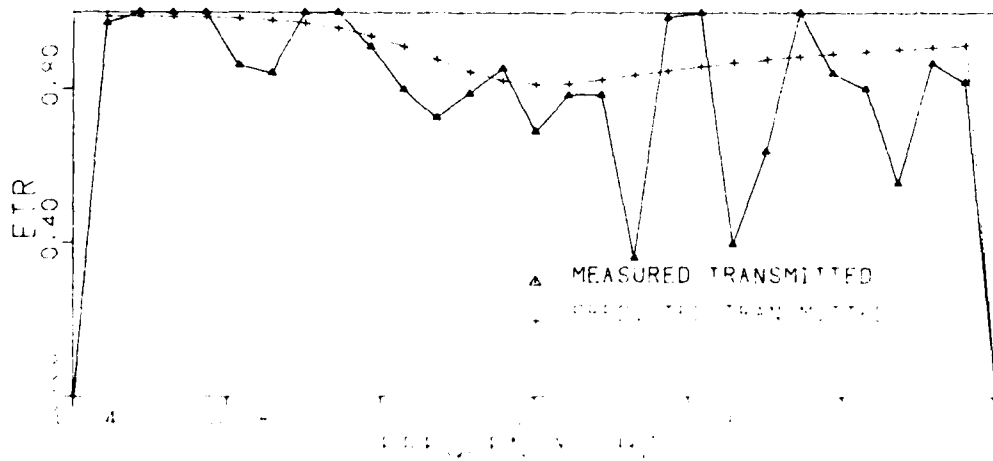
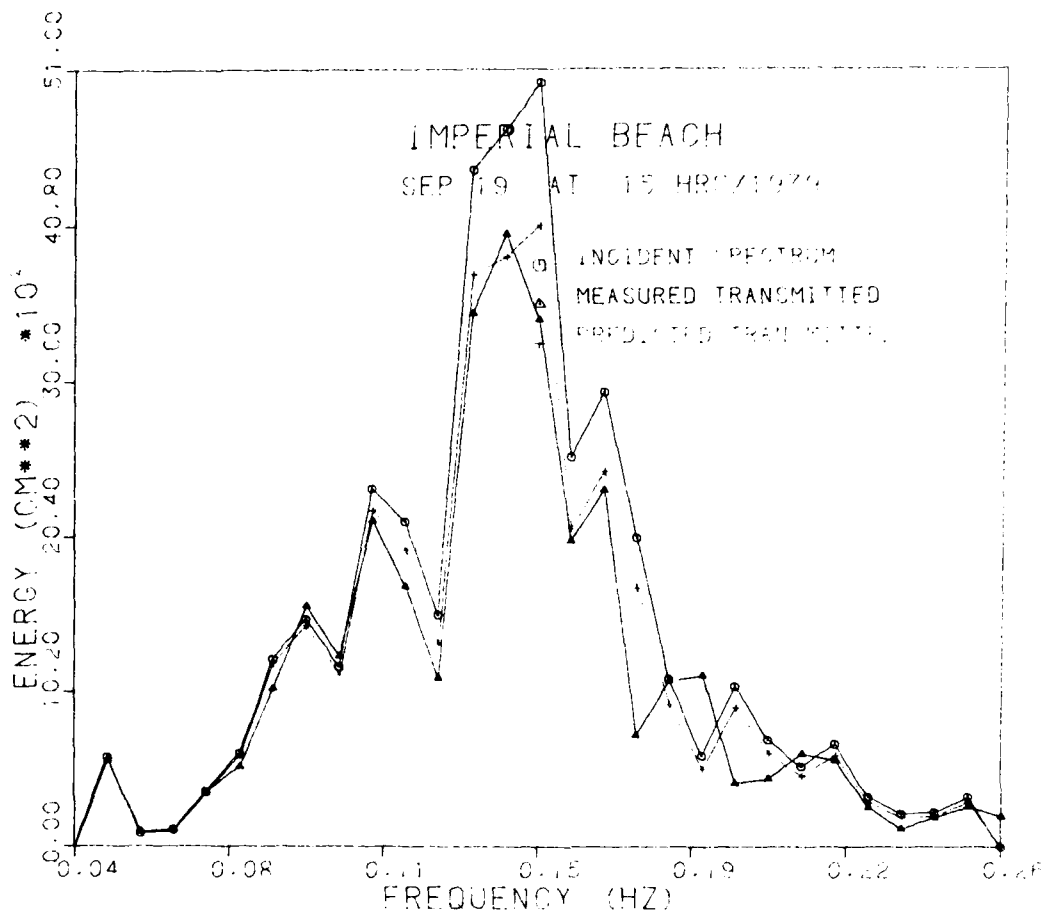

IMPERIAL BEACH TFB. SEPTEMBER 1979
RUN NO. 21

SEP 19 AT 15 HRS/1979

CYLINDRICAL FLOAT, HEIGHT = 127.00 CM.
FLOAT DIAMETER = 63.50 CM EFFECTIVE TETHER LENGTH = 401.5 CM
X-SECTIONAL AREA = 8064.5 CM. SQ. VOLUME = 402199.9 CC
FLOAT SPACING = 127.00 CM FLOAT DENSITY = 0.6500 GM/CC
DEPTH TO C.L. = 357.42 CM WATER DEPTH = 819.9 CM
DELTA F = 0.0078 NO. BANDS = 28
TETHERED FLOAT NATURAL FREQUENCY = 0.134
DEPTH OF WATER TO WAVELENGTH RATIO = 0.14813
CD = 1.000 CM = 0.550 DCD = 0.550

SIGNIFICANT WAVE HEIGHT, INCIDENT (CM) = 69.421
ACTUAL SIGNIFICANT WAVE HEIGHT, TRANSMITTED (CM) = 62.659
PREDICTED SIGNIFICANT WAVE HEIGHT, TRANSMITTED (CM) = 64.839

ACTUAL PERFORMANCE

ENERGY TRANSMISSION FACTOR = 0.815
HEIGHT TRANSMISSION FACTOR = 0.903

PERFORMANCE ESTIMATES

ENERGY TRANSMISSION FACTOR = 0.872
HEIGHT TRANSMISSION FACTOR = 0.934

NUMBER OF ROWS = 16

AD-A092 059

NAVAL OCEAN SYSTEMS CENTER SAN DIEGO CA

F/G 13/2

HARDWARE AND PERFORMANCE EVALUATION: TETHERED FLOAT BREAKWATER --ETC(U)

JUL 80 J D CLINKENBEARD

NL

UNCLASSIFIED

NOSC/TR-574

2 OF 2

3/1 06/8



END
DATE
FILMED
1-81
DTIC

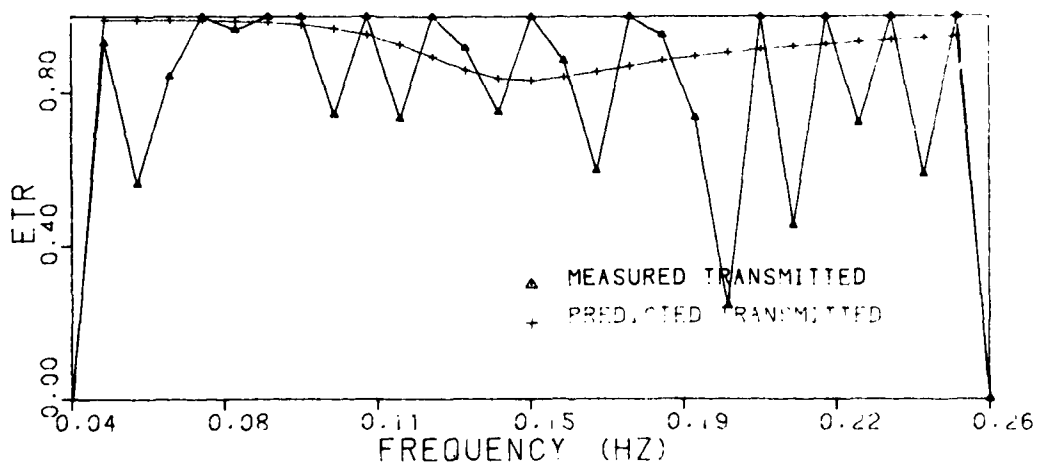
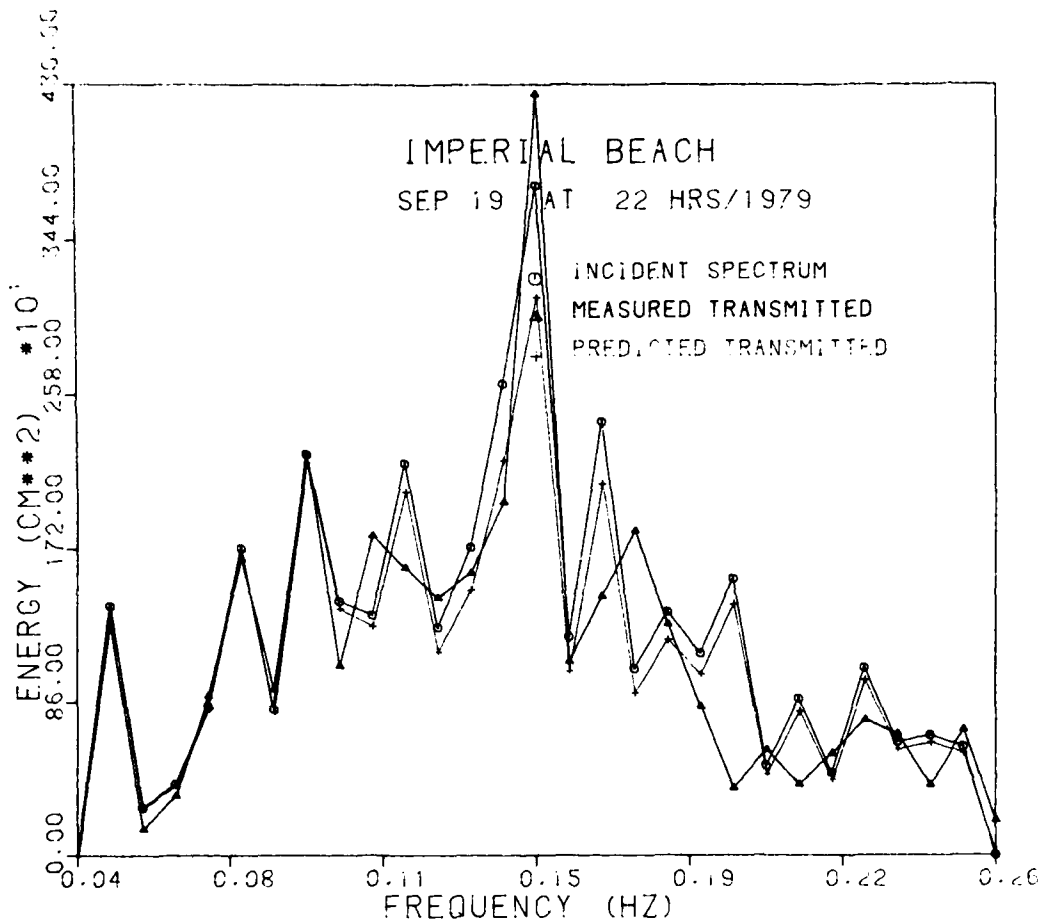

IMPERIAL BEACH TFB. SEPTEMBER 1979
RUN NO. 22

SEP 19 AT 22 HRS/1979

CYLINDRICAL FLOAT, HEIGHT = 127.00 CM.
FLOAT DIAMETER = 63.50 CM EFFECTIVE TETHER LENGTH = 401.5 CM
X-SECTIONAL AREA = 8064.5 CM. SQ. VOLUME = 402199.9 CC
FLOAT SPACING = 127.00 CM FLOAT DENSITY = 0.6500 GM/CC
DEPTH TO C.L. = 426.42 CM WATER DEPTH = 888.9 CM
DELTA F = 0.0078 NO. BANDS = 28
TETHERED FLOAT NATURAL FREQUENCY = 0.134
DEPTH OF WATER TO WAVELENGTH RATIO = 0.15591
CD = 1.000 CM = 0.550 DCD = 0.550

SIGNIFICANT WAVE HEIGHT, INCIDENT (CM) = 65.346
ACTUAL SIGNIFICANT WAVE HEIGHT, TRANSMITTED (CM) = 62.326
PREDICTED SIGNIFICANT WAVE HEIGHT, TRANSMITTED (CM) = 62.351

ACTUAL PERFORMANCE

ENERGY TRANSMISSION FACTOR = 0.910
HEIGHT TRANSMISSION FACTOR = 0.954

PERFORMANCE ESTIMATES

ENERGY TRANSMISSION FACTOR = 0.910
HEIGHT TRANSMISSION FACTOR = 0.954

NUMBER OF ROWS = 16

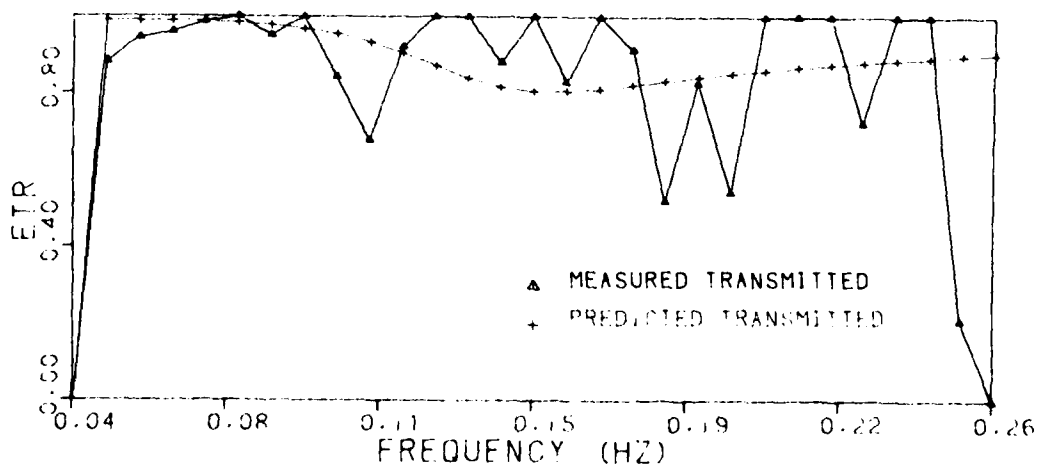
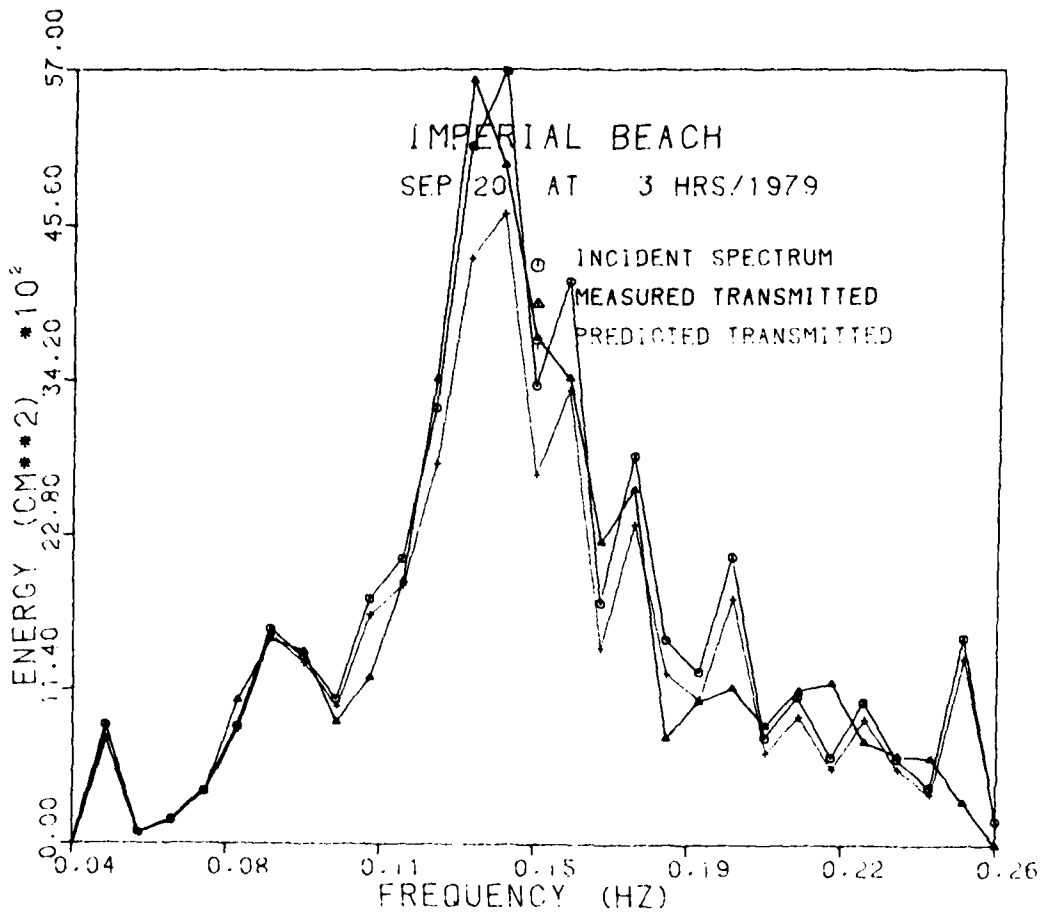

IMPERIAL BEACH TFB. SEPTEMBER 1979
RUN NO. 23

SEP 20 AT 3 HRS/1979

CYLINDRICAL FLOAT, HEIGHT = 127.00 CM.
FLOAT DIAMETER = 63.50 CM EFFECTIVE TETHER LENGTH = 401.5 CM
X-SECTIONAL AREA = 8064.5 CM. SQ. VOLUME = 402199.9 CC
FLOAT SPACING = 127.00 CM FLOAT DENSITY = 0.6500 GM/CC
DEPTH TO C.L. = 332.42 CM WATER DEPTH = 794.9 CM
DELTF = 0.0078 NO. BANDS = 28
TETHERED FLOAT NATURAL FREQUENCY = 0.134
DEPTH OF WATER TO WAVELENGTH RATIO = 0.13562
CD = 1.000 CM = 0.550 DCD = 0.550

SIGNIFICANT WAVE HEIGHT, INCIDENT (CM) = 76.682
ACTUAL SIGNIFICANT WAVE HEIGHT, TRANSMITTED (CM) = 73.661
PREDICTED SIGNIFICANT WAVE HEIGHT, TRANSMITTED (CM) = 71.273

ACTUAL PERFORMANCE

ENERGY TRANSMISSION FACTOR = 0.923
HEIGHT TRANSMISSION FACTOR = 0.961

PERFORMANCE ESTIMATES

ENERGY TRANSMISSION FACTOR = 0.864
HEIGHT TRANSMISSION FACTOR = 0.929

NUMBER OF ROWS = 16

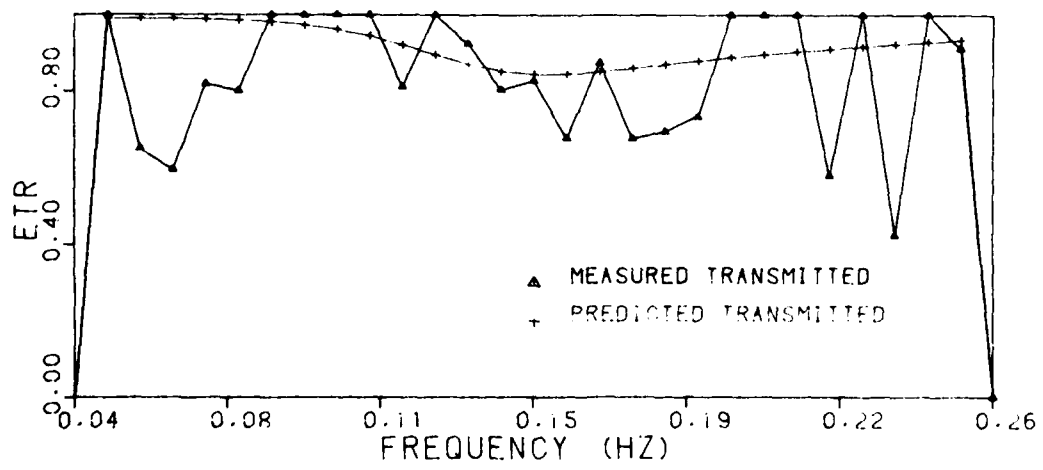
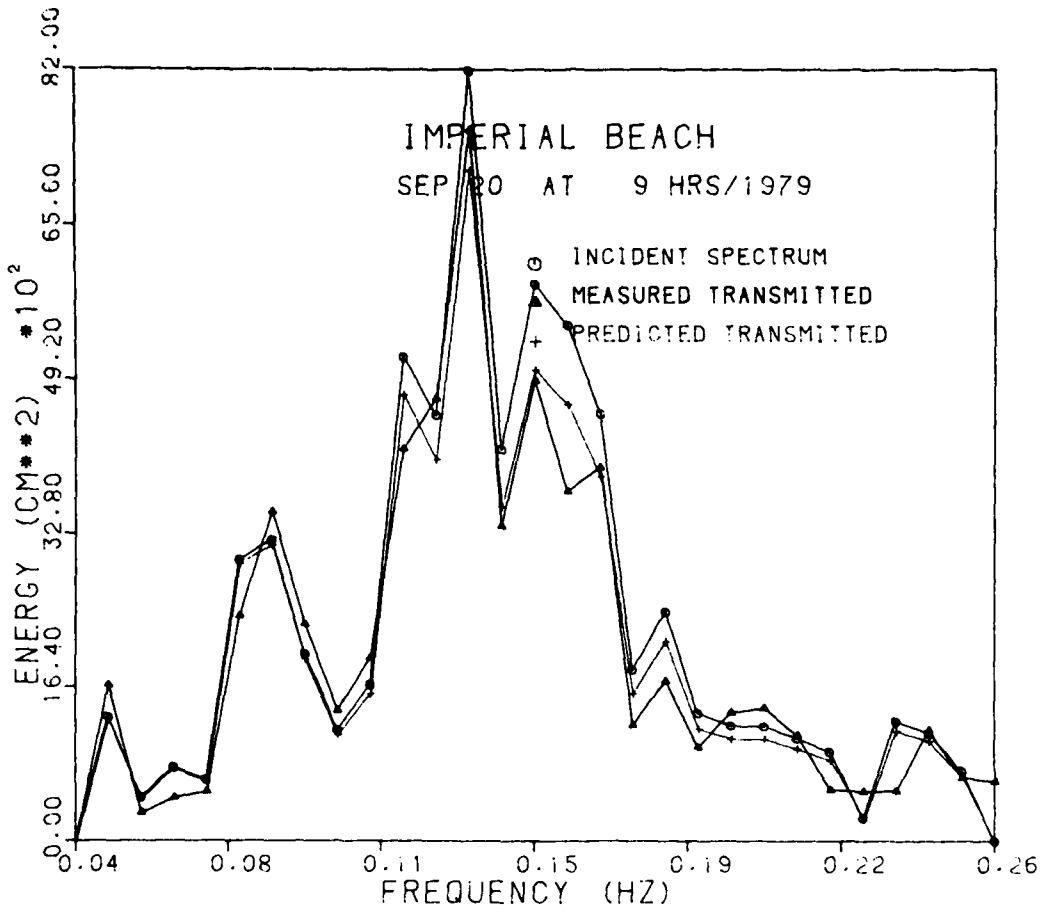

IMPERIAL BEACH TFB. SEPTEMBER 1979
RUN NO. 24

SEP 20 AT 9 HRS/1979

CYLINDRICAL FLOAT, HEIGHT = 127.00 CM.
FLOAT DIAMETER = 63.50 CM EFFECTIVE TETHER LENGTH = 401.5 CM
X-SECTIONAL AREA = 8064.5 CM. SG. VOLUME = 402199.9 CC
FLOAT SPACING = 127.00 CM FLOAT DENSITY = 0.6500 GM/CC
DEPTH TO C.L. = 439.42 CM WATER DEPTH = 901.9 CM
DELTF = 0.0078 NO. BANDS = 28
TETHERED FLOAT NATURAL FREQUENCY = 0.134
DEPTH OF WATER TO WAVELENGTH RATIO = 0.13626
CD = 1.000 CM = 0.550 DCD = 0.550

SIGNIFICANT WAVE HEIGHT, INCIDENT (CM) = 89.095
ACTUAL SIGNIFICANT WAVE HEIGHT, TRANSMITTED (CM) = 84.658
PREDICTED SIGNIFICANT WAVE HEIGHT, TRANSMITTED (CM) = 85.122

ACTUAL PERFORMANCE

ENERGY TRANSMISSION FACTOR = 0.903
HEIGHT TRANSMISSION FACTOR = 0.950

PERFORMANCE ESTIMATES

ENERGY TRANSMISSION FACTOR = 0.913
HEIGHT TRANSMISSION FACTOR = 0.955

NUMBER OF ROWS = 16

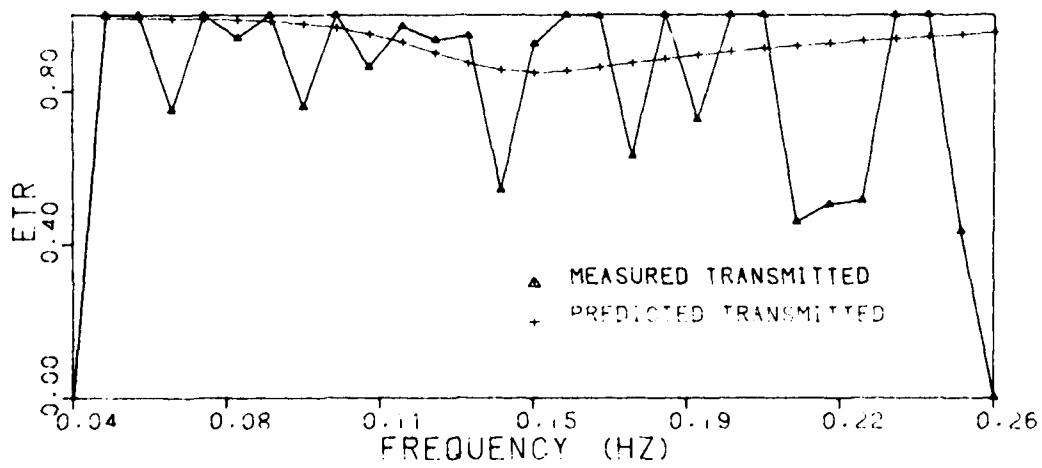
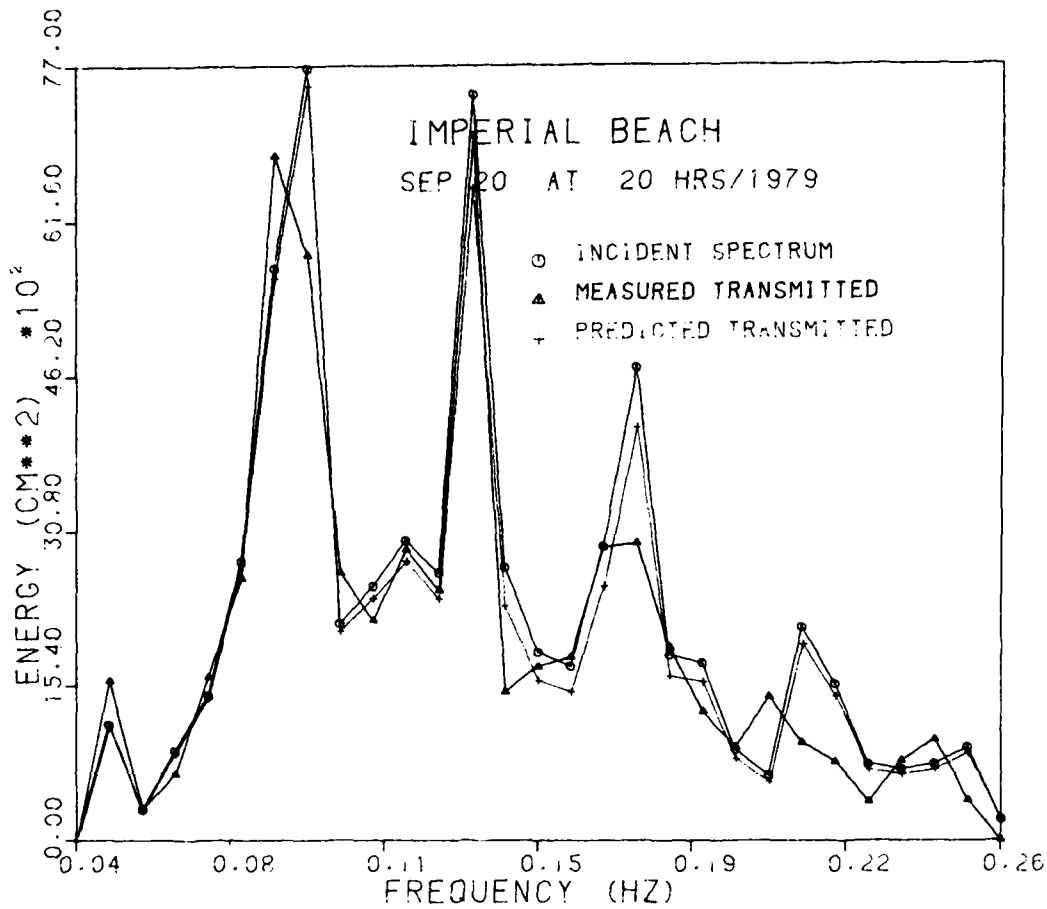

IMPERIAL BEACH TFB. SEPTEMBER 1979
RUN NO. 25

SEP 20 AT 20 HRS/1979

CYLINDRICAL FLOAT, HEIGHT = 127.00 CM.
FLOAT DIAMETER = 63.50 CM EFFECTIVE TETHER LENGTH = 401.5 CM
X-SECTIONAL AREA = 8064.5 CM. SQ. VOLUME = 402199.9 CC
FLOAT SPACING = 127.00 CM FLOAT DENSITY = 0.6500 GM/CC
DEPTH TO C.L. = 464.92 CM WATER DEPTH = 927.4 CM
DELTF = 0.0078 NO. BANDS = 28
TETHERED FLOAT NATURAL FREQUENCY = 0.134
DEPTH OF WATER TO WAVELENGTH RATIO = 0.09091
CD = 1.000 CM = 0.550 DCD = 0.550

SIGNIFICANT WAVE HEIGHT, INCIDENT (CM) = 88.654
ACTUAL SIGNIFICANT WAVE HEIGHT, TRANSMITTED (CM) = 83.429
PREDICTED SIGNIFICANT WAVE HEIGHT, TRANSMITTED (CM) = 85.240

ACTUAL PERFORMANCE

ENERGY TRANSMISSION FACTOR = 0.886
HEIGHT TRANSMISSION FACTOR = 0.941

PERFORMANCE ESTIMATES

ENERGY TRANSMISSION FACTOR = 0.924
HEIGHT TRANSMISSION FACTOR = 0.961

NUMBER OF ROWS = 16

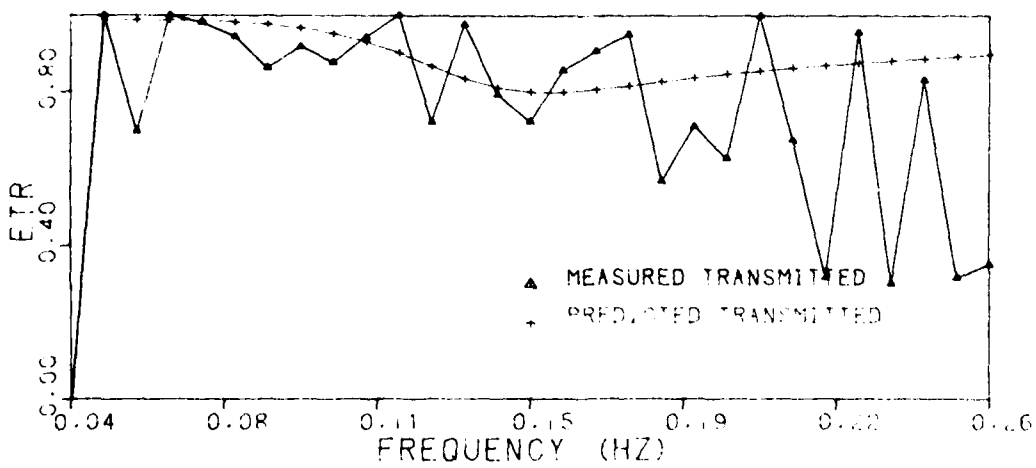
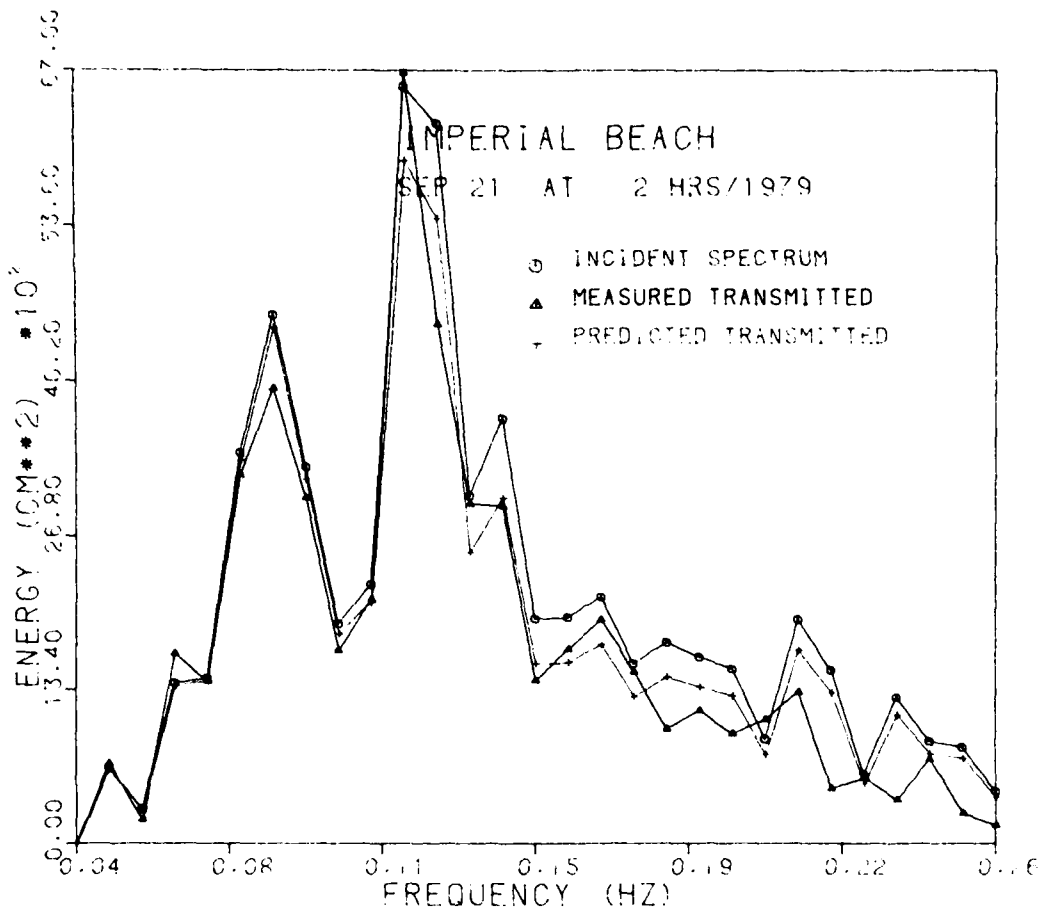

IMPERIAL BEACH TFB. SEPTEMBER 1979
RUN NO. 26

SEP 21 AT 2 HRS/1979

CYLINDRICAL FLOAT, HEIGHT = 127.00 CM.
FLOAT DIAMETER = 63.50 CM EFFECTIVE TETHER LENGTH = 401.5 CM
X-SECTIONAL AREA = 8064.5 CM. SQ. VOLUME = 402199.9 CC
FLOAT SPACING = 127.00 CM FLOAT DENSITY = 0.6500 GM/CC
DEPTH TO C.L. = 320.42 CM WATER DEPTH = 782.9 CM
DELTA F = 0.0078 NO. BANDS = 28
TETHERED FLOAT NATURAL FREQUENCY = 0.134
DEPTH OF WATER TO WAVELENGTH RATIO = 0.10750
CD = 1.000 CM = 0.550 DCD = 0.550

SIGNIFICANT WAVE HEIGHT, INCIDENT (CM) = 85.932
ACTUAL SIGNIFICANT WAVE HEIGHT, TRANSMITTED (CM) = 78.296
PREDICTED SIGNIFICANT WAVE HEIGHT, TRANSMITTED (CM) = 81.138

ACTUAL PERFORMANCE

ENERGY TRANSMISSION FACTOR = 0.830
HEIGHT TRANSMISSION FACTOR = 0.911

PERFORMANCE ESTIMATES

ENERGY TRANSMISSION FACTOR = 0.892
HEIGHT TRANSMISSION FACTOR = 0.944

NUMBER OF ROWS = 16

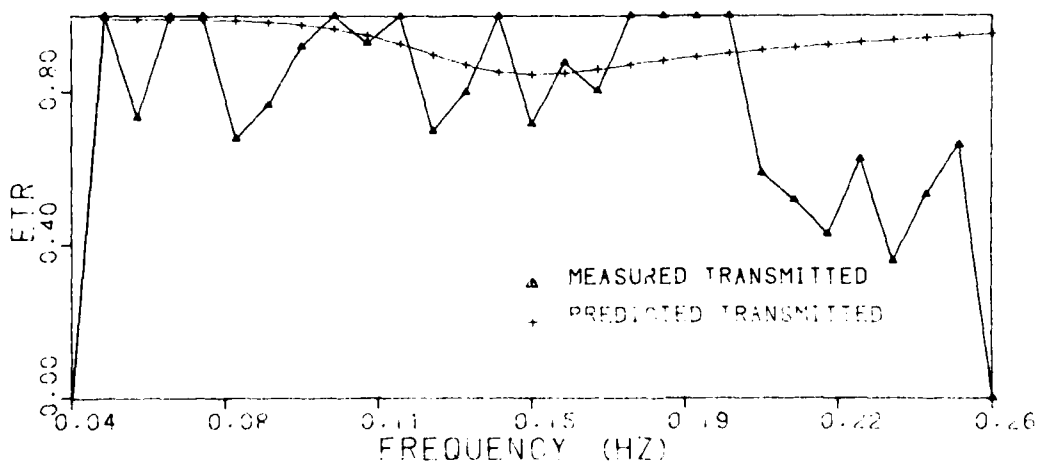
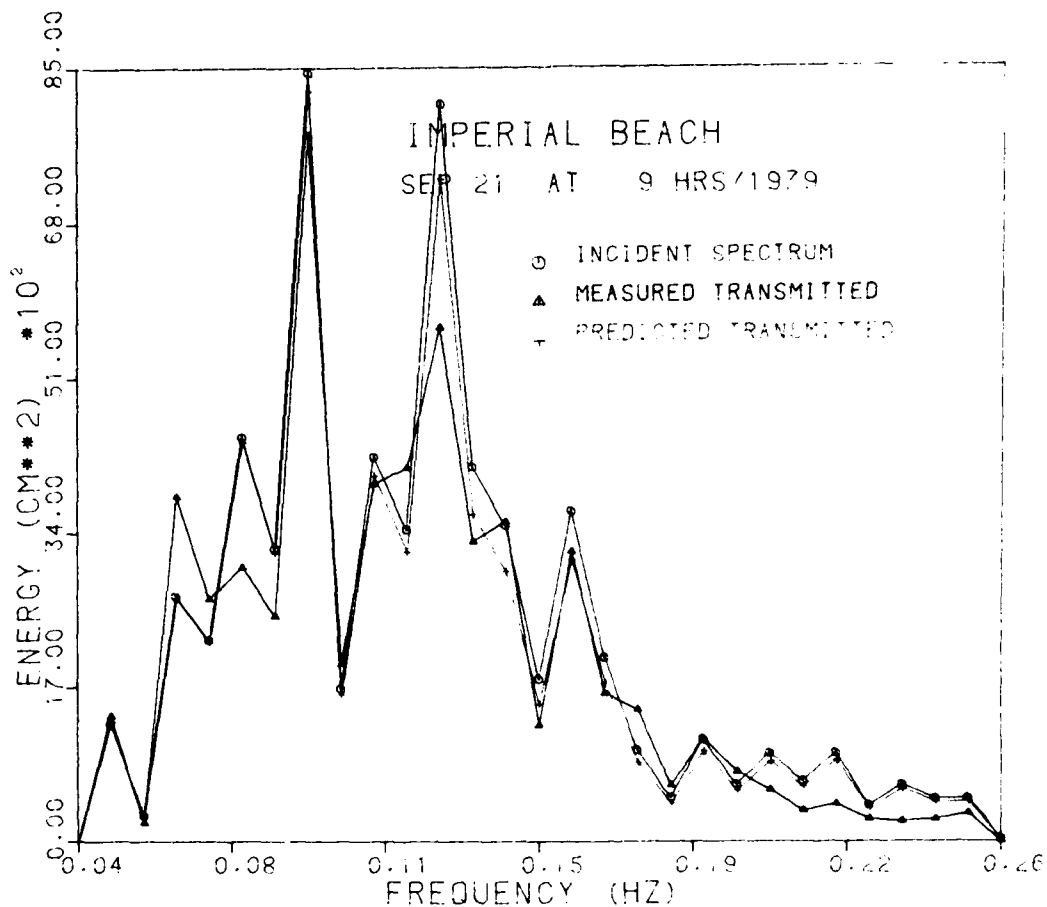

IMPERIAL BEACH TFB. SEPTEMBER 1979
RUN NO. 27

SEP 21 AT 9 HRS/1979

CYLINDRICAL FLOAT, HEIGHT = 127.00 CM.
FLOAT DIAMETER = 63.50 CM EFFECTIVE TETHER LENGTH = 401.5 CM
X-SECTIONAL AREA = 8064.5 CM. SQ. VOLUME = 402199.9 CC
FLOAT SPACING = 127.00 CM FLOAT DENSITY = 0.6500 GM/CC
DEPTH TO C.L. = 456.92 CM WATER DEPTH = 919.4 CM
DELTF = 0.0078 NO. BANDS = 28
TETHERED FLOAT NATURAL FREQUENCY = 0.134
DEPTH OF WATER TO WAVELENGTH RATIO = 0.09048
CD = 1.000 CM = 0.550 DCD = 0.550

SIGNIFICANT WAVE HEIGHT, INCIDENT (CM) = 87.899
ACTUAL SIGNIFICANT WAVE HEIGHT, TRANSMITTED (CM) = 82.959
PREDICTED SIGNIFICANT WAVE HEIGHT, TRANSMITTED (CM) = 84.725

ACTUAL PERFORMANCE

ENERGY TRANSMISSION FACTOR = 0.891
HEIGHT TRANSMISSION FACTOR = 0.944

PERFORMANCE ESTIMATES

ENERGY TRANSMISSION FACTOR = 0.929
HEIGHT TRANSMISSION FACTOR = 0.964

NUMBER OF ROWS = 16

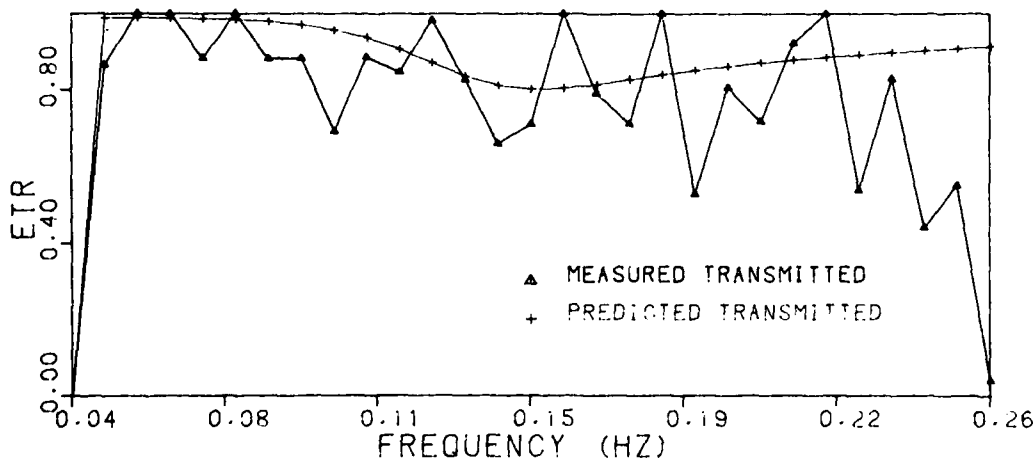
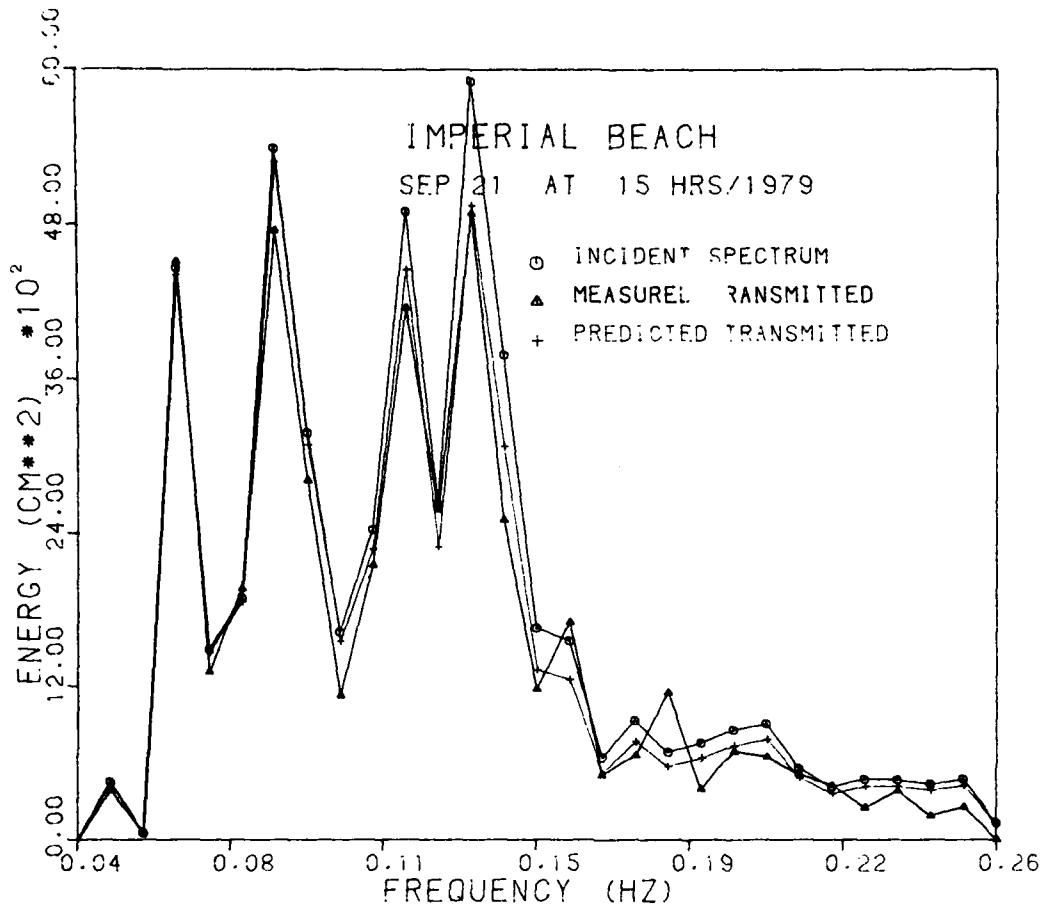

IMPERIAL BEACH TFB. SEPTEMBER 1979
RUN NO. 28

SEP 21 AT 15 HRS/1979

CYLINDRICAL FLOAT, HEIGHT = 127.00 CM.
FLOAT DIAMETER = 63.50 CM EFFECTIVE TETHER LENGTH = 401.5 CM
X-SECTIONAL AREA = 8064.5 CM. SQ. VOLUME = 402199.9 CC
FLOAT SPACING = 127.00 CM FLOAT DENSITY = 0.6500 GM/CC
DEPTH TO C.L. = 331.92 CM WATER DEPTH = 794.4 CM
DELTA = 0.0078 NO. BANDS = 28
TETHERED FLOAT NATURAL FREQUENCY = 0.134
DEPTH OF WATER TO WAVELENGTH RATIO = 0.12626
CD = 1.000 CM = 0.550 DCD = 0.550

SIGNIFICANT WAVE HEIGHT, INCIDENT (CM) = 78.004
ACTUAL SIGNIFICANT WAVE HEIGHT, TRANSMITTED (CM) = 72.297
PREDICTED SIGNIFICANT WAVE HEIGHT, TRANSMITTED (CM) = 74.250

ACTUAL PERFORMANCE

ENERGY TRANSMISSION FACTOR = 0.859
HEIGHT TRANSMISSION FACTOR = 0.927

PERFORMANCE ESTIMATES

ENERGY TRANSMISSION FACTOR = 0.906
HEIGHT TRANSMISSION FACTOR = 0.952

NUMBER OF ROWS = 16