

AD-A092 104

ROYAL SIGNALS AND RADAR ESTABLISHMENT MALVERN (ENGLAND)
MICROWAVE FREQUENCY MEMORY (U)

F/G 9/3

MAR 80 C M BOYNE
RSRE-MEMO-3257

DRIC-BR-74217

NL

UNCLASSIFIED

1 of 1
AD-A092 104



END
DATE
FILMED
1-81
DTIC

UNLIMITED

✓ BR74217

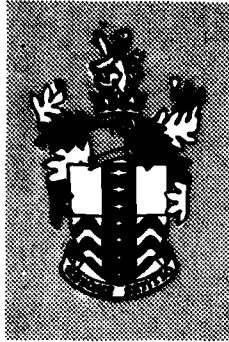

LEVEL II

①
b.s.

RSRE

MEMORANDUM No.3257 ✓

ROYAL SIGNALS & RADAR ESTABLISHMENT

MICROWAVE FREQUENCY MEMORY

Author: C M Boyne

DTIC
ELECTE
NOV 25 1980
S D
E

PROCUREMENT EXECUTIVE,
MINISTRY OF DEFENCE,
RSRE MALVERN,
WORCS.

This document is the property of Procurement Executive, Ministry of Defence.
Its contents should not be made public either directly or indirectly without
approval from HBM Secretary of State for Defence (Director RSRE).

AD A092104

RSRE MEMORANDUM No.3257

BDC FILE COPY

ROYAL SIGNALS AND RADAR ESTABLISHMENT

Memorandum 3257

13 IFRIC
 74211

Title: MICROWAVE FREQUENCY MEMORY
 Author: J.C. M. Boyne
 Date: March 1980

PSRE-1.2.2.3.7

42/161

SUMMARY

A circuit is described which is capable of remembering the frequency of a single pulse of R.F. in the band 9.2-9.8 GHz. The minimum pulse duration is 100 nsec and the set-on accuracy is to within ± 5 MHz. Essentially, the memory is an oscillator which can be set to one of a number of discrete frequencies by the injection of an R.F. pulse. The oscillator can be switched to a new frequency at any time by injecting a new signal.

Accession For	
NTIS Gw&I	<input checked="" type="checkbox"/>
DDC TAB	<input type="checkbox"/>
Unannounced	<input type="checkbox"/>
Justification	
By _____	
Distribution/	
Availability Codes	
Dist	A

This memorandum is for advance information. It is not necessarily to be regarded as a final or official statement by Procurement Executive, Ministry of Defence

MICROWAVE FREQUENCY MEMORY

C M Boyne

INTRODUCTION

This memorandum is concerned with a frequency memory system which has an unlimited storage time. Such a system was built, having a set-on accuracy to within 10 MHz in a bandwidth of 500 MHz minimum, for a single RF input pulse of 100 nsec duration or greater. To achieve this performance, two multimode oscillators (MMOs) were combined. One of these oscillators had a coarse set-on accuracy in a wide band, whilst the other had a finer set-on accuracy in a narrower band.

THEORY OF MMO OPERATION

Several theoretical accounts of MMO behaviour are contained in the literature ^{1,2,3}. Essentially the memory is achieved by setting an oscillator close to the frequency of an input signal, such that the oscillator remains on that frequency when the input signal is removed. One form of MMO is shown in Fig (1). The condition for oscillation follows the usual Nyquist criteria; namely that the loop gain be unity and the total phase shift around the loop (ϕ) be an integral number of 2π ie

$$\phi = 2\pi f\tau = 2n\pi \quad (n = 1, 2, 3, \dots)$$

$$\text{or} \quad f = \frac{n}{\tau} \quad (1)$$

where τ = loop delay.

Equation (1) says that there is a comb of possible oscillation frequencies (ie modes of the system) which are separated by the reciprocal of the round-trip delay time.

Two distinct function blocks are associated with Fig (1); the limiter and the gain shaping block. The behaviour of these two components determines the ability of the oscillator to oscillate at a single mode, adjacent to the frequency of an injected signal. The action of the limiter is to give a differential transmission gain to a large signal in the presence of other small signals. In practice this discrimination is in the range 3-6 dB. Referring to Fig (1), if a strong signal is fed into the loop, thereby stimulating a nearby mode, the limiting action will reduce the gain of all other modes with respect to the stimulated mode. In principle, the gain of all unwanted modes can be reduced below unity leaving only the desired mode oscillating. However, whilst the limiter is effective in suppressing amplitude modulation within the loop, it is unable to suppress frequency modulation ^{1,2}. FM roding occurs as a result of the nature of the limiter, whereby pairs of modes centrally displaced about the stimulated mode are strongly coupled through the non-linearity. It is possible to suppress this moding by choosing a gain-shaping block (Fig (1)) which has a parabolic relationship with frequency - maximum gain occurring at band centre. This is equivalent to making the average gain of possible FM modes less than the gain of the stimulated mode. Alternative methods of suppressing FM moding have been suggested ¹.

SURFACE ACOUSTIC WAVE MMO

A ten mode MMO using a SAW device as the loop delay line has been built and described by M F Lewis ⁴. The SAW device had an approximately parabolic pass-band with a 3 dB bandwidth of 100 MHz and a delay of 100 nsec. The mode spacing for this MMO was 10 MHz. The limiting action was provided by the saturation of the loop sustaining amplifiers.

This MMO was developed by the author (C M Boyne) to allow operation with a single RF pulse of 100 nsec minimum duration. In particular, attention was paid to the input/output coupling and to locking power requirements. From the above discussion on FM mode suppression it is clear that ripples within the pass-band, such as would be produced by poorly matched input/output couplings, must be avoided. A convenient input port is between the two loop-sustaining amplifiers as shown in Fig (2); the output was resistively padded in the usual way. In operation, the loop is quenched (ie one loop amplifier turned off - see Fig (2)) until an input signal (video detected) crosses a threshold; at this point the loop is allowed to oscillate. Since the signal must pass through the SAW delay line before arriving at the switched amplifier, the bias rise time of this amplifier need be no faster than 100 nsec (the SAW propagation delay). The benefits of this approach are twofold. Firstly, since, in the absence of an injected signal, loop oscillation builds up from noise, it is only necessary to "seed" the oscillator with a small input signal. In this way, instead of the 100-200 mW signal power required to lock a continuously running MMO, only microwatts are required to lock a switched MMO. Secondly, false triggering due to noise can be recognised and the oscillator quenched before any significant output occurs. This can be inferred from Figs (3) and (4) in which the MMO output for no signal input and for a real signal input, respectively, are shown. In the absence of an input signal the MMO produces no significant output for 2 μ sec, whereas with an injected signal significant output occurs within 1 μ sec. Thus a threshold detector gated-on 1 μ sec after the MMO had been triggered would see a 4 to 1 difference in amplitude, depending on whether a real signal had initiated the MMO or not.

Fig (4) shows the settling time during which mode suppression is active. This is typically 1.5 μ sec; ie 15 recirculations of the loop. The moding during this period reflects the sinc function response of the input pulse of 100 nsec duration. Essentially, the RF spectrum of this pulse can only be supported at the mode line frequencies (where there is potentially net loop gain) and if the pulse duration matches the loop delay, then one mode is preferentially stimulated and acts to suppress other modes through the limiter operation. Fig (5) shows the situation for varying pulsewidths. Note that although the optimal pulse length can result in two modes being equally stimulated (namely when the centre frequency of the pulse lies midway between two modes), the MMO set-on accuracy is unaffected, since one mode will inevitably suppress the other (ie an imbalance in their amplitudes due to noise, variations in large-signal gain, etc, will allow suppression of the smaller signal by the limiter action). If the pulse is too short (Fig (5)), then any one of several modes may be excited. Conversely, if the pulse is too long, then a mode would only be excited when the frequency difference between the pulse and that mode was small.

MICROWAVE MMO

Two MMOs based on the principles outlined above have been built at X-band. These will be referred to as the Gunn diode and GaAs FET MMO respectively. Whereas a Gunn Diode MMO has been reported of elsewhere ³, this paper is believed to be the first describing a GaAs FET MMO.

In comparison with SAW MMOs, microwave MMOs have a much wider memory bandwidth (several hundred MHz) but an inferior set-on accuracy. However, it will be shown later on how these MMOs can be combined to achieve the wide bandwidth of the microwave MMO with the fine set-on accuracy of the SAW MMO.

a Gunn Diode MMO

A Gunn diode multiresonant oscillator, shown schematically in Fig (6), was configured on microstrip. The diode was a Plessey TEO 101 (100 mW power output) in a P4 package. The substrate was alumina ($\epsilon_r = 9.6$).

A three section printed transformer was used to transform a load impedance of 100Ω to the diode; one end of this transformer was circulator coupled to a 50Ω load (serving as the output port), the remaining circulator arm served as the input port. The resonator was a one metre open-circuited length of semi-rigid co-axial delay line, coiled to six inches diameter.

The external circuit load impedance seen by the Gunn diode comprises 100Ω resistance in parallel with an open circuit transformed through $2\pi f\tau$ electrical degrees of delay line; where f = operating frequency, τ = propagation time of delay line. The contribution by the delay line is periodic with frequency since

$$\begin{aligned} \theta^0 &= 2\pi f\tau \\ &= 2\pi n \quad (\text{for } f = \frac{n}{\tau}) \quad (n = 1, 2, 3, \dots) \end{aligned} \quad (2)$$

where θ^0 = electrical length of delay line.

The net effect of this parallel combination is to satisfy the conditions for oscillation at frequencies spaced by $1/\tau$ ie

$$\begin{aligned} \text{Re}Z_c(\omega) + \text{Re} \left| Z_d(A) \right| &= 0 \\ \text{Im}Z_c(\omega) + \text{Im} \left| Z_d(A) \right| &= 0 \end{aligned} \quad (3)$$

where $Z_c(\omega)$ = external circuit impedance (a function of frequency)

$Z_d(A)$ = device impedance (a function of RF amplitude A)

Stated another way, the possible modes of oscillation are those for which the (Gunn diode) device line intersects the external circuit load line; maximum stability occurring for orthogonal intersections⁷ (see Fig (7)). NB This represents a necessary but not sufficient condition to guarantee oscillation - for a full discussion see references (5) and (6).

The performance of this MMO was sensitive to the value of the Gunn bias voltage. A change of 100-200 mV was sufficient to prevent locking of a mode at the memory band edges. The behaviour of the MMO (in the absence of an injected RF signal) with bias was similar to that described by Magarshack⁸. As the bias was increased from threshold (~ 2.8 V), there was a discontinuous jump in oscillation towards a lower frequency. Thereafter, increasing the bias value resulted in smaller jumps to lower

frequencies, where the jumps were separated by the expected mode line separation. Optimum bias for MMO operation was located at approximately the centre of this frequency jumping region. A final adjustment of bias was made whilst attempting to mode lock over this band.

As discussed earlier, it is necessary to provide a limiter and gain shaping element for MMO operation. The limiting action was provided by the oscillator self-saturation. Whilst measurements of the frequency dependence of the Gunn diode negative resistance have not been made, it is felt that this is likely to provide the pass-band shaping required. Indeed, no other band shaping elements were included.

Using a delay line for 100 MHz mode separation (~ 1 metre), it was possible to lock seven modes (equivalent to 700 MHz bandwidth) with a single pulse of ~ 25 nsec duration (25 nsec was an instrument limitation rather than the minimum pulse width required). The unwanted mode suppression was better than 30 dB over the 700 MHz operating band. This suppression reflects the deviation of the gain shaping profile from an ideal parabola. In principle, for a noiseless MMO, infinite suppression will be afforded by an ideal gain profile; but for this it is necessary to control the profile to better than 2% for ten mode operation. The effect of noise is to leave small residual peaks at the unwanted mode lines - although these may be at least - 60 dB on the wanted mode amplitude.

The RF locking power requirement was ~ 200 mW to guarantee locking anywhere in the 700 MHz band. Switching the bias to the Gunn diode from threshold to its operating point, at the moment of RF injection, produced no significant improvement in locking power requirement. This is due to the strong dependence of the device impedance, and hence frequency of oscillation, with bias voltage. A better approach is to terminate the open circuited delay line in Fig (6) with a shunt PIN diode, followed by a 50Ω load - the characteristic impedance of the delay line. With the Gunn diode biased to its normal MMO operating point, and with the PIN biased high resistance, the external circuit impedance, seen by the Gunn diode is 33Ω . For the particular diode used for the MMO, this resistance is sufficient to prevent oscillation ie

$$\operatorname{Re} Z_c(\omega) + \operatorname{Re} \left| Z_d(A) \right| > 0 \quad (4)$$

Switching the PIN to low resistance (which can be achieved in ~ 2 nsec at X-band) at the moment of RF injection, then allows the MMO to oscillate. Immediately prior to oscillation, the Gunn diode behaves as a low gain amplifier switched by the injected RF. At the point of oscillation the effective gain rises and stable oscillation then ensues. Preliminary experiments using this technique have indicated an improvement in locking power requirement of - 20 dB ie a few milliwatts instead of a few hundred milliwatts. Further experiments over a wider locking bandwidth and using more suitable PIN switches are needed before the usefulness of this technique can be determined.

A comparison of the results of this work with that of Curtiss³ is difficult. A spurious-free bandwidth (ie unwanted mode rejection > 50 dB) of 500-600 MHz has been achieved in this work, although 700 MHz bandwidth with - 30 dB spurious rejection has been demonstrated. In contrast, Curtiss has described a MMO having 20 modes with 132 MHz mode separation as well as several other MMOs having smaller mode separations. However,

it appears that only 6 to 8 modes can be obtained without spurious moding or missing modes (no figures are available for unwanted mode rejection); this compares with 6 spurious free modes obtained in this work. The locking power requirement for a continuously operating MMO is ~ 200 mW for both this and Curtiss' work. However, a possibility of reducing this power requirement has been proposed here that has shown promising results. Further experiments are needed to show if the technique can be implemented without degrading the MMO bandwidth performance.

b GaAs FET MMO

A multimode oscillator having the same configuration as Fig (1) was built at X-band. The loop sustaining amplifier was a GaAs FET device with a flat pass-band. The limiting function of this MMO again relied upon amplifier saturation. The delay line was a length of co-axial cable (~ 2.5 metres) giving a mode separation of ~ 75 MHz. The gain shaping element was provided by the passive circuit shown in Fig (8) where the reflection coefficient, Γ_0 , at the circulator output is related to Γ_1 and Γ_2 as follows:

$$\Gamma_0 = \Gamma_1 - \Gamma_2 \quad (5)$$

where $\Gamma_n = |\Gamma_n| e^{i\theta}$ $n = 0, 1, 2$
 $\theta = \text{phase angle}$

Thus if we consider the open circuited end of line ℓ_2 to be the reference phase plane ($\theta = 0$), we can express Γ_0 as:

$$\Gamma_0 = |\Gamma| [1 - \exp i 2\pi(\ell_1 - \ell_2)/\lambda] \quad (6)$$

From this we see that for $\ell_1 = \ell_2$, $\Gamma_0 = 0$. This is the expected result for a 3 dB 90° hybrid terminated in identical load impedances at its two output ports. However, when $(\ell_1 - \ell_2) = m\lambda$, where m is an odd integer, Γ_0 is a maximum. For m even, Γ_0 is a minimum. Thus the output amplitude is periodic with frequency, the period depending on the differential rate of change of phase:

$$\frac{d\theta}{df} = \frac{2\pi}{c} (\ell_1 - \ell_2) \quad (7)$$

Equation (7) shows that for long periodic repeats, $(\ell_1 - \ell_2)$ should be made small.

With the MMO operating continuously, seven modes could be locked with a single RF pulse of 50 mW peak power. However, with the inclusion of a PIN switch in the loop the MMO could be operated in a quenched manner (as for the SAW MMO), resulting in a dramatic decrease in locking power requirement. Only 300 nW was needed for operation over ~ 500 MHz bandwidth.

The unwanted mode suppression was better than 50 dB with respect to the stimulated mode. An example of the purity of the output is shown in Fig (9); this shows no trace of the possible modes that would be located ± 75 MHz with respect to the mode at 10.03 GHz.

MICROWAVE AND SAW MMOs COMBINED

A combined microwave and SAW MMO circuit has been built. The microwave MMO acts as a fast set-on local oscillator that downconverts the input signal (ie signal to be memorised) into the frequency band of the SAW MMO. In this way one obtains the wide bandwidth of the microwave MMO with the fine resolution of the SAW MMO. The parameters of the two MMOs and the overall performance are listed in Table (1) below:-

TABLE (1)

	Microwave MMO	SAW MMO	Overall
Centre frequency	9.5 GHz	400 MHz	9.5 GHz
Bandwidth	600 MHz	100 MHz	600 MHz
Minimum input signal duration	10 nsec	100 nsec	100 nsec
Set-on accuracy	$\leq \pm 50$ MHz	$\leq \pm 50$ MHz	$\leq \pm 5$ MHz
Output response time*	10 nsec	100 nsec	100 nsec

* This is defined as the time after which a memory output signal can be taken from the MMO. As explained earlier, a further period of time is needed to obtain maximum purity of the output spectrum.

The details of the circuit are shown in Fig (10). In operation, the input signal is routed to mixers 1 and 2. Mixer 2 merely introduces a 400 MHz frequency offset to the input signal - 400 MHz being the IF frequency (ie centre frequency of the SAW MMO). The microwave MMO locks-on to within ± 50 MHz of this signal and its output is split to feed mixers 1 and 3. The output of mixer 1 is now $400 + \Delta f$ MHz, where Δf represents the error (which may be negative) between the input frequency and the microwave MMO output (neglecting the 400 MHz offset). Thus, Δf lies in the range ± 50 MHz. The SAW MMO locks-on to within ± 5 MHz of $400 + \Delta f$ MHz and its output then feeds mixer 3, whose output is now the original frequency ± 5 MHz. This output is a CW tone that will continue until the MMOs are quenched. The stability of this signal is determined by the temperature coefficient of the microwave MMO, the SAW having an inherently high stability. At present, no measurements on stability have been made.

DISCUSSION

A circuit has been described which is capable of remembering the frequency of an RF pulse of 100 nsec duration or greater, with an accuracy to within ± 5 MHz over 600 MHz bandwidth. As stated previously, the pulse duration should be ideally equal to the MMO loop delay (although a tolerance of $\sim \pm 20\%$ is allowable); this means that long input pulses should be gated with a PIN switch.

It has been shown that quenching loop oscillation prior to signal injection results in smaller locking power requirements of ~ 300 nW and $1 \mu\text{W}$ for the GaAs FET and SAW MMO respectively. A method has been proposed for reducing the RF input power for the Gunn MMO. Further experiments are needed to confirm a preliminary experimental result of ~ 20 dB reduction in RF power.

For a small increase in circuit complexity, time division multiplexing can be implemented in the circuit of Fig (10). This allows the memory bandwidth to be doubled from 600 MHz to 1.2 GHz. Such a scheme is shown in Fig (11). Essentially, the single sideband nature of mixer 2 allows an upper or lower sideband to be switched, with a 300 MHz offset, into the processing band of the microwave MMO. (See Fig (12)). Mixer 3 is switched in synchronism with mixer 2 to ensure correct sideband selection at the output. In operation, either mixer 2 can be switched at a fixed rate until a signal is registered, or a separate band activity detector (for example two partially overlapping filters with individual detector outputs) can select the appropriate sideband. It should be noted that the centre frequency of the SAW MMO would now have to be 300 MHz. In general, for a microwave MMO having x MHz of processing bandwidth, the above technique results in $2x$ MHz of effective memory bandwidth providing the local oscillator and lower frequency MMO have a centre frequency of $x/2$ MHz.

In principle further MMOs can be cascaded to produce wider bandwidths or finer set-on accuracies. However, for MMOs with mode separation larger than 100 MHz the input pulse lengths become unreasonably short. In addition, preserving a parabolic gain relationship with frequency becomes more difficult for wider bandwidths. For these reasons it is likely that ~ 1 GHz processing bandwidth (or 2 GHz effective bandwidth for time division multiplexing) will represent an upper limit for this particular MMO configuration. Finer set-on accuracies to ± 500 KHz should easily be achieved by cascading one more MMO at IF. For processing bandwidths much greater than 1 GHz, alternative techniques will have to be developed to replace FM mode suppression by gain shaping. One such technique, proposed by Edson¹, relied on feedback from an auxiliary loop to the main MMO loop to cancel any tendency towards frequency modulation.

CONCLUSION

Combining multimode oscillators enables single pulse (≥ 100 nsec), high speed (~ 100 nsec) microwave frequency memory systems to be built having an instantaneous processing bandwidth of better than 500 MHz. The memory is active, in the sense that the output is a CW tone the frequency of which is that of the input RF pulse (within ± 5 MHz).

For bandwidths greater than 1-2 GHz, techniques other than gain-shaping with frequency will have to be developed to suppress spontaneous phase modulation within the MMO.

It is recommended that the GaAs FET, rather than Gunn, MMO approach is more appropriate at microwave frequencies. This is because RF input power levels are comparatively smaller for the GaAs FET and the gain shaping is more readily controlled. It is anticipated that in an integrated approach the GaAs FET loop amplifier could embody the required gain shaping and also provide the loop "quenching switch" (leaving only a delay line to be connected).

ACKNOWLEDGEMENTS

The contributions made by members of P2 and L3 divisions at RSRE Malvern are gratefully acknowledged.

REFERENCES

- 1 Frequency Memory in Multimode Oscillators. W A Edson, IRE Transactions-Circuit Theory, Vol CT-2, March 1955, pp 58-66.
- 2 Theory of Multimoding in SAW Oscillators. M F Lewis, RSRE SAW Research Memo No 3, August 1976.
- 3 Microwave Frequency Memory using GaAs Transferred Electron Devices. W R Curtiss, RCA Contract No N00014-74-C-0371, Dec 1974.
- 4 Design of a Ten Frequency Programmable Multimode Oscillator. M F Lewis. RSRE SAW Research Memo No 10, Feb 1979.
- 5 Some Basic Characteristics of Broadband Negative Resistance Oscillator Circuits. K Kurokawa, Bell System Tech Journal, July-Aug 1969, pp 1937-1955.
- 6 Injection Locking of Microwave Solid-State Oscillators. K Kurokawa, Proc IEEE, Vol 61, No 10, Oct 1973, pp 1386-1410.
- 7 Stability Criteria for Phase Locked Oscillators. G H B Hansson and K I Lundstrom, IEEE Trans Microwave Theory Tech, Vol MTT-20, No 10, Oct 1972, pp 641-645.
- 8 Gunn Oscillator as a Frequency Memory Device. J Magarshack, IEEE Trans Microwave Theory Tech, Vol MTT-16, Dec 1968, pp 1055-1057.

Please note that some of
references quoted above may
not be generally available.

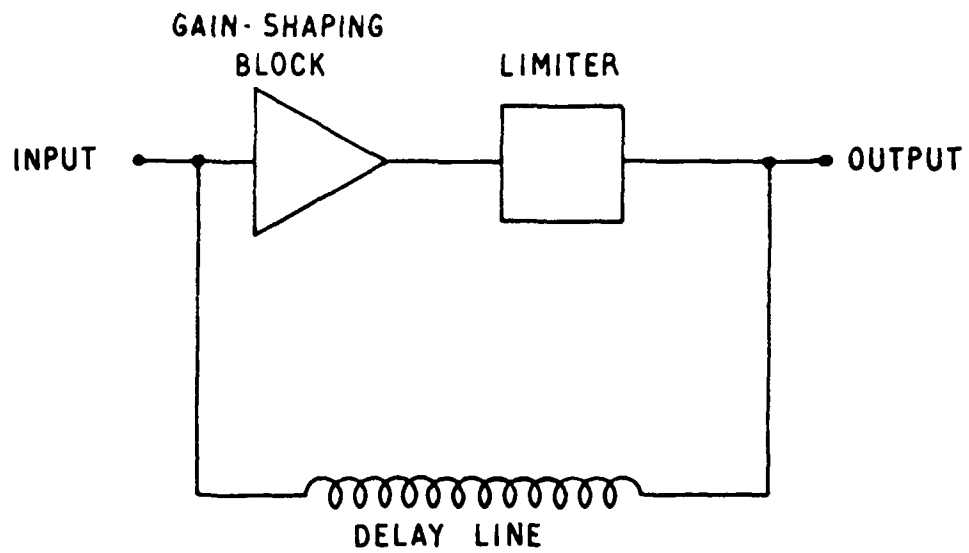

FIG. 1. TYPICAL MULTIMODE OSCILLATOR
CONFIGURATION

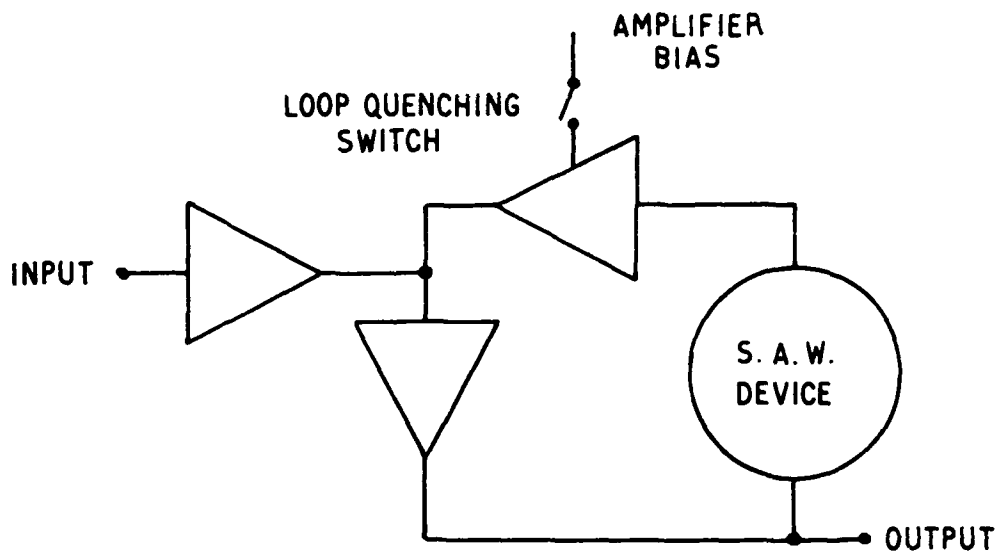

FIG. 2. SCHEMATIC REPRESENTATION OF S.A.W.
M.M.O.

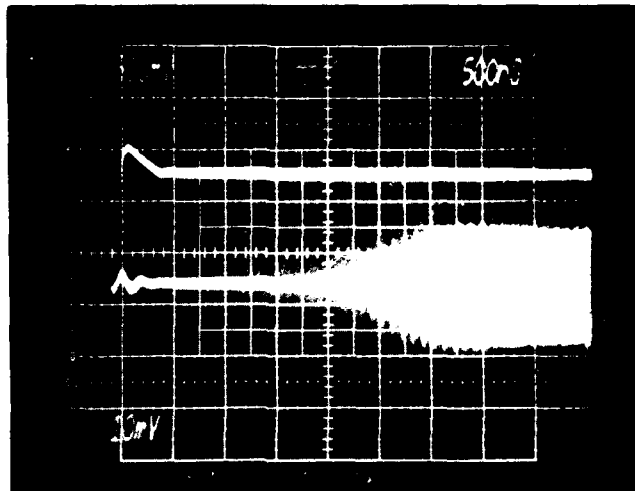

FIG. 3 : TOP TRACE : AMPLIFIER BIAS TURN - ON
 BOTTOM TRACE : M.M.O. OUTPUT (NO SIGNAL INJECTION)
 SCALE : 500 nsec. PER DIV. (HORIZONTAL)

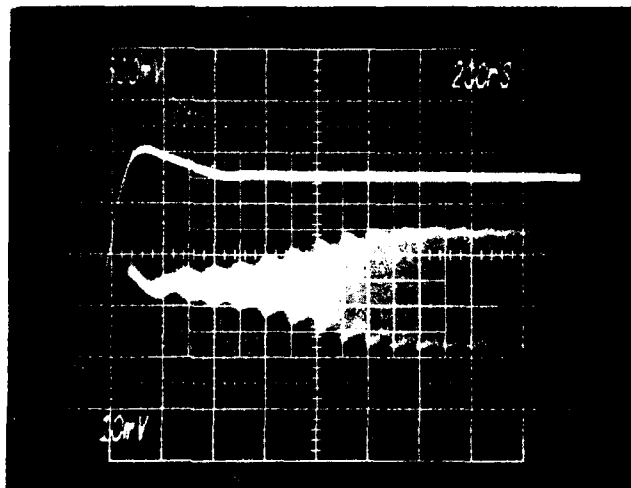

FIG. 4 : TOP TRACE : AMPLIFIER BIAS TURN - ON
 BOTTOM TRACE : M.M.O. OUTPUT (WITH R.F. SIGNAL INJECTED AT THE MOMENT OF AMPLIFIER BIAS TURN - ON)
 SCALE : 200 nsec. PER DIV. (HORIZONTAL)

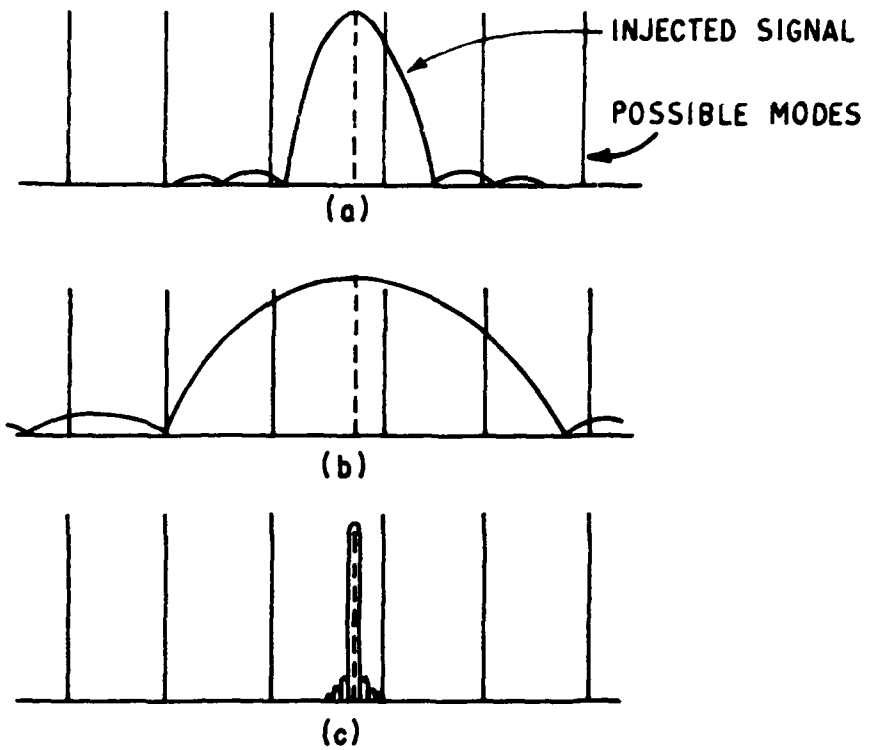

FIG. 5. THE EFFECT OF VARYING RF PULSEWIDTH WITH THE NUMBER OF MODES STIMULATED
 (a) OPTIMAL PULSE LENGTH
 (b) PULSE TOO SHORT
 (c) PULSE TOO LONG

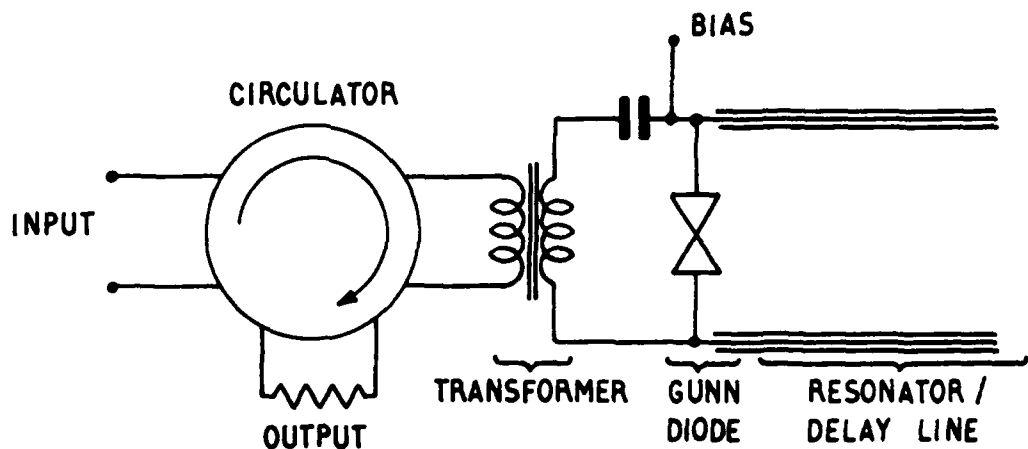

FIG. 6. GUNN DIODE M.M.O.

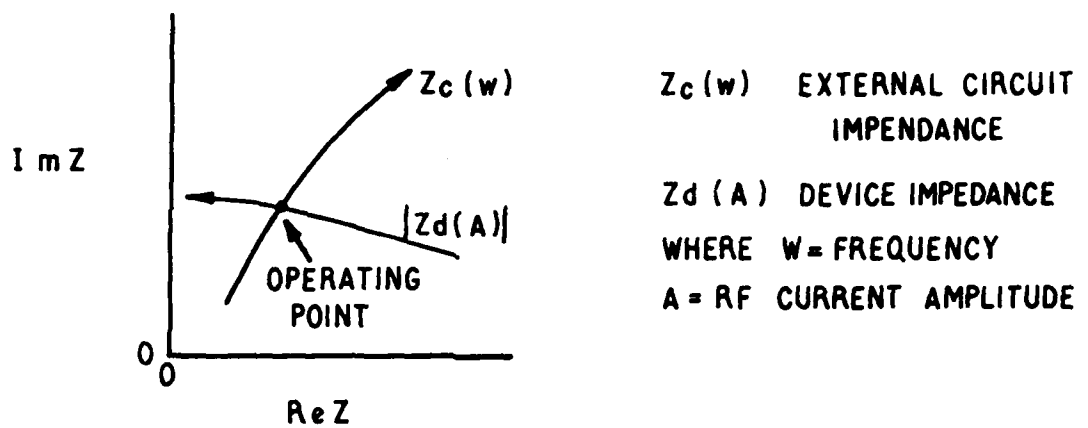

FIG. 7. : DETERMINATION OF GUNN DIODE OPERATING POINT

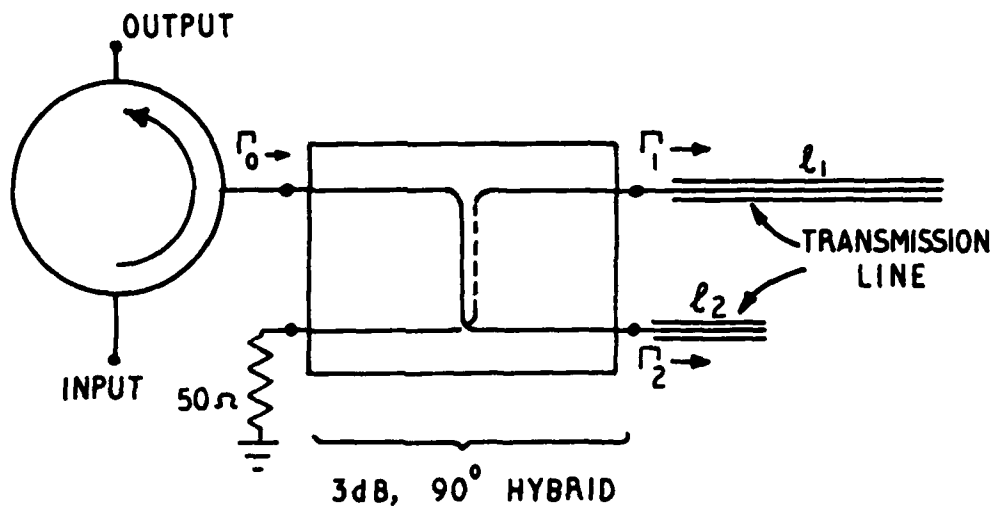

FIG. 8. : GAIN SHAPING ELEMENT USED FOR THE GaAs FET M.M.O.

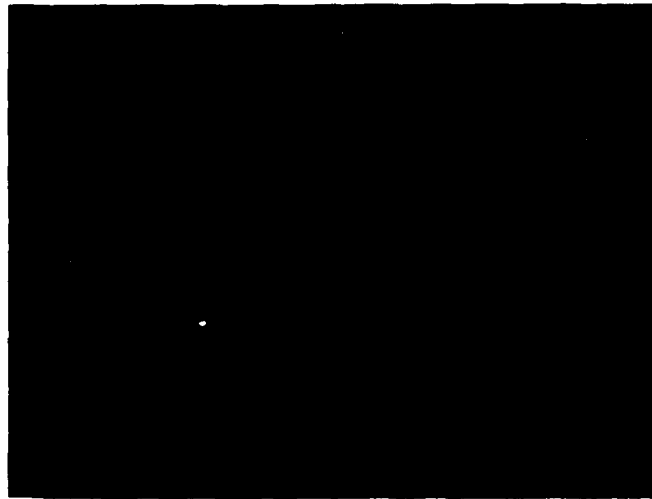

FIG. 9 : OUTPUT SPECTRAL PURITY OF THE GaAs FET M.M.O.
 SCALE : 20 MHz / DIV. (HORIZONTAL)
 10 dB / DIV. (VERTICAL)

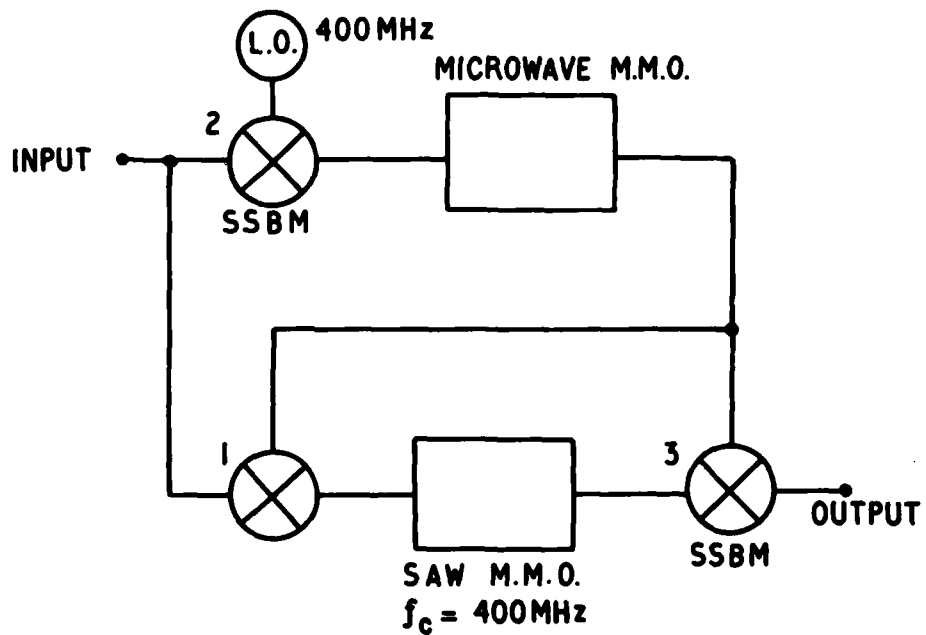

FIG. 10. : COMBINED MICROWAVE AND S.A.W. M.M.O.s

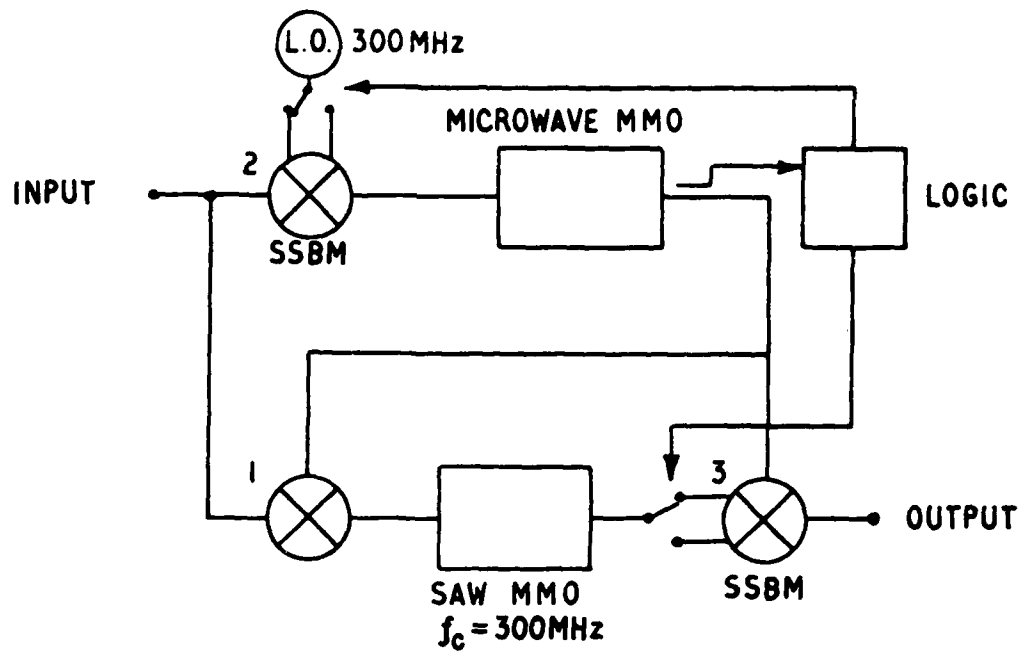

FIG. 11. APPLICATION OF TIME DIVISION MULTIPLEXING TO THE COMBINED M.M.O. CIRCUIT OF FIG.10.

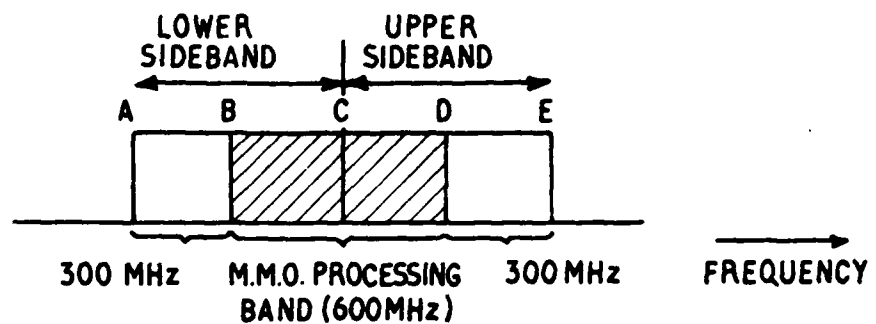

FIG. 12. FREQUENCY DOMAIN REPRESENTATION OF TIME DIVISION MULTIPLEXING.

WHEN PROCESSING THE LOWER SIDEBAND, A IS UP CONVERTED (BY 300MHz) TO B, B TO C AND C TO D. SIMILARLY, FOR THE UPPER SIDEBAND, E IS DOWN CONVERTED TO D, D TO C AND C TO B.