

AD-A092 181

NAVAL OCEAN SYSTEMS CENTER SAN DIEGO CA
NONRESONANT ACOUSTIC PROJECTOR PROJECT. MECHANICAL 5-50 HZ DEVI--ETC(U)

F/G 17/1

JUN 80 H A WILCOX

UNCLASSIFIED NOSC/TR-579

NL

NOSC

END
DATE
FILMED
8h
DTIC

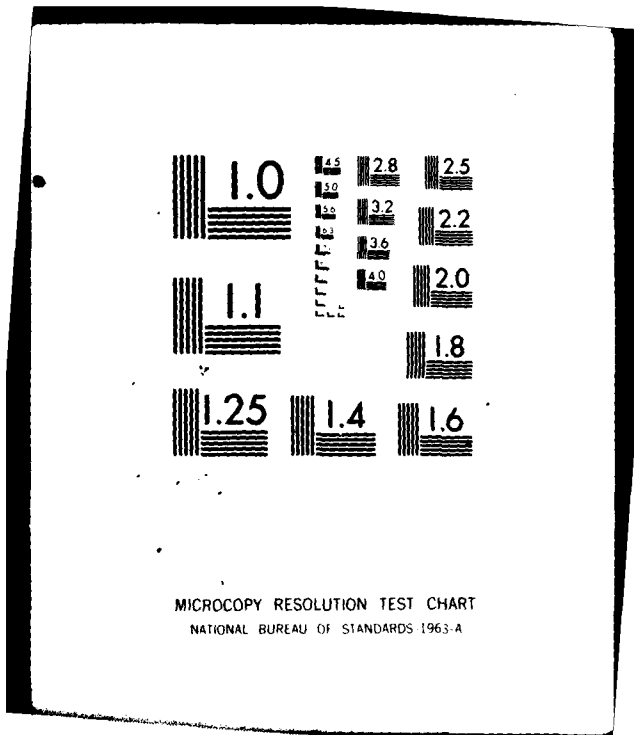

MICROCOPY RESOLUTION TEST CHART
NATIONAL BUREAU OF STANDARDS 1963-A

LEVEL *12* SC

NOSC

NOSC TR 579

NOSC TR 579

DTIC
NOV 25 1980

Technical Report 579

NONRESONANT ACOUSTIC PROJECTOR PROJECT

**Mechanical 5-50 Hz device provides stable
underwater acoustic output with frequency and
amplitude controllable and independent of depth**

HA Wilcox

12 June 1980

Final Report: 1 May 1979 to 30 April 1980

Approved for public release; distribution unlimited

NAVAL OCEAN SYSTEMS CENTER
SAN DIEGO, CALIFORNIA 92152

80 11 19 040

AD A 092181

DDC FILE COPY



NAVAL OCEAN SYSTEMS CENTER, SAN DIEGO, CA 92152

AN ACTIVITY OF THE NAVAL MATERIAL COMMAND

SL GUILLE, CAPT, USN

Commander

HL BLOOD

Technical Director

ADMINISTRATIVE INFORMATION

Work was performed with IED funds under Program Element 62766N, Project F61512, Task Area ZF-61-512-001 (NOSC 530 ZD51), and for the Transduction Sciences Block Program under Program Element 62711N, Task ZF-11-121-001 (NOSC SU12), by members of the Marine Sciences and Technology Directorate (Codes 53 and 52). This report covers work from 1 May 1979 to 30 April 1980 and was approved for publication 21 July 1980.

The support of NOSC IR/IED management is gratefully acknowledged. JM Walton restarted the thinking toward a flat linkage approach and did an outstanding job on the engineering design. GO Pickens originally suggested the flat linkage approach, contributed valuable counsel, and managed the Transdec tests. TE Stixrud gave valuable advice, assisted at the Transdec tests, and managed the Lake Pend Oreille tests. LE McKinley gave valuable advice, as did VC Anderson and FR Abbott. Interest in and support for the Lake Pend Oreille tests by DL Carson and JB Fransdal is gratefully acknowledged. Drafting and machine work were performed well by CV Cargill, Jr and R Roa, respectively.

Released under authority of
JD Hightower, Head
Environmental Sciences Department

METRIC CONVERSION

<u>To convert from</u>	<u>To</u>	<u>Multiply by</u>
feet	metres (m)	~ 3.05 E-01
pounds	kilograms (kg)	~ 4.54 E-01
pounds of force per square inch (psi)	pascals (Pa)	~ 6.89 E+03
dynes/cm ²	Pa	1.00 E-01
ergs	joules (J)	1.00 E-07
horsepower	watts (W)	~ 7.46 E+02

UNCLASSIFIED

SECURITY CLASSIFICATION OF THIS PAGE (When Data Entered)

14 NOSC/TR-579

REPORT DOCUMENTATION PAGE		READ INSTRUCTIONS BEFORE COMPLETING FORM
1. REPORT NUMBER NOSC Technical Report 579 (TR 579) ✓	2. GOVT ACCESSION NO. AD-A092181	3. RECIPIENT'S CATALOG NUMBER
4. TITLE (and Subtitle) NONRESONANT ACOUSTIC PROJECTOR PROJECT. Mechanical 5-50 Hz device provides stable underwater acoustic output with frequency and amplitude controllable and independent of depth.	5. TYPE OF REPORT & PERIOD COVERED Final rept. 1 May 1979 to 30 April 1980	6. PERFORMING ORG. REPORT NUMBER
7. AUTHOR(s) HA Wilcox	8. CONTRACT OR GRANT NUMBER(s)	
9. PERFORMING ORGANIZATION NAME AND ADDRESS Naval Ocean Systems Center San Diego, CA 92152	10. PROGRAM ELEMENT, PROJECT, TASK AREA & WORK UNIT NUMBERS 62766N, F61512, ZF-61 512 001 (NOSC 530 ZD51); 62711N, ZF-11-121-001 (NOSC SU12)	
11. CONTROLLING OFFICE NAME AND ADDRESS F61512, F11121	12. REPORT DATE 12 June 1980	13. NUMBER OF PAGES 50
14. MONITORING AGENCY NAME & ADDRESS (if different from Controlling Office) 12 48	15. SECURITY CLASS. (of this report) Unclassified	15a. DECLASSIFICATION/DOWNGRADING SCHEDULE
16. DISTRIBUTION STATEMENT (of this Report) Approved for public release; distribution unlimited		
17. DISTRIBUTION STATEMENT (of the abstract entered in Block 20, if different from Report)		
18. SUPPLEMENTARY NOTES		
19. KEY WORDS (Continue on reverse side if necessary and identify by block number) Underwater sound generators Mechanical components Sources Linkages Standards Nonresonant Acoustic Projector		
20. ABSTRACT (Continue on reverse side if necessary and identify by block number) The nonresonant acoustic projector was designed, fabricated, and tested without significant difficulties. It met all its specifications, and it proved the principle of a mechanical projector whose operating depth, frequency, and amplitude of piston throw can be simultaneously or independently varied without incurring significant interactions among the variables. The validity of considering the nonresonant acoustic projector as a standard source was demonstrated.		

DD FORM 1 JAN 73 1473

EDITION OF 1 NOV 65 IS OBSOLETE
S/N 0102-LF-014-6601

UNCLASSIFIED
SECURITY CLASSIFICATION OF THIS PAGE (When Data Entered)

393159

HM

(UNCLASSIFIED)

SECURITY CLASSIFICATION OF THIS PAGE (When Data Entered)

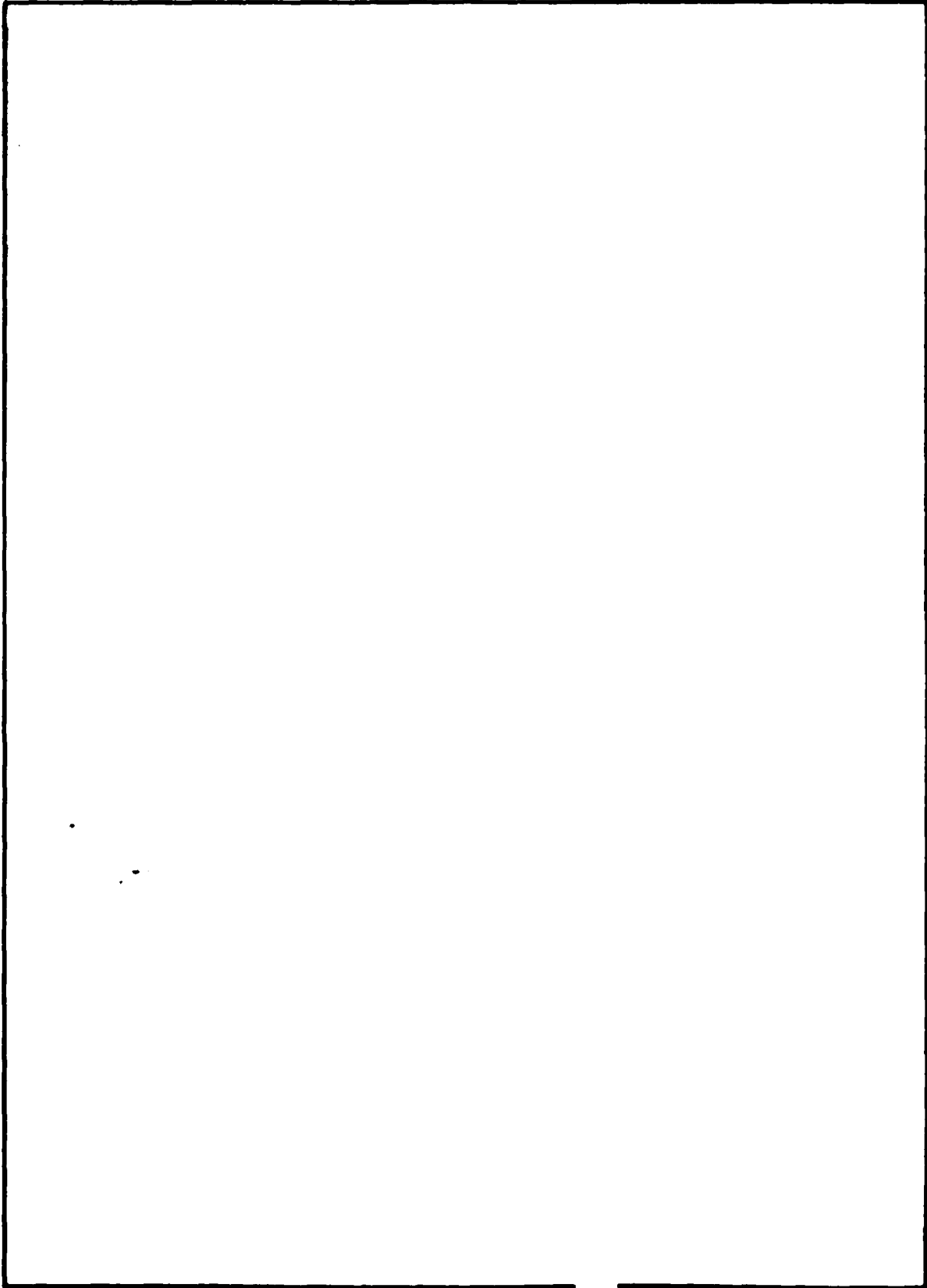

(UNCLASSIFIED)

SECURITY CLASSIFICATION OF THIS PAGE (When Data Entered)

OBJECTIVE

Since there are no inexpensive acoustic sources in the 5 to 50 Hz spectral region for generating controlled underwater sounds, investigate a newly designed nonresonant source of the mechanical type. Build and demonstrate operation of the new type projector at a source level of about 172 dB re 1 μ Pa at 1 m.

RESULTS

1. The nonresonant acoustic projector was designed, fabricated, and tested without significant difficulties.
2. It met all its specifications, and it proved the principle of a mechanical projector whose operating depth, frequency, and amplitude of piston throw can be simultaneously or independently varied without incurring significant interactions among the variables.
3. The validity of considering the nonresonant acoustic projector as a standard source was demonstrated.

RECOMMENDATIONS

1. Apply the nonresonant acoustic projector type of acoustic source to such Navy problems as: (a) probing and characterizing the ocean's various acoustic paths, (b) measuring effective horizontal sound speed over ocean paths of Navy interest, and (c) calibrating and measuring the sensitivity of the Navy's ocean surveillance arrays.
2. Promptly develop the "switchable nonresonant acoustic projector" concept for application to significant Navy problems.

Accession For	
NTIS GRA&I	<input checked="" type="checkbox"/>
DTIC TAB	<input type="checkbox"/>
Unannounced	<input type="checkbox"/>
Justification	
By _____	
Distribution/ _____	
Availability Codes	
Dist	Avail and/or Special
A	

EVOLUTION OF THE DESIGN CONCEPT

The Nonresonant Acoustic Projector (NRAP) Project got its start with this author's suggestion for a system called Friendly Acoustic Sources. On finding that there were no suitable, inexpensive sources in the 5 to 50 Hz spectral region available for the Friendly Acoustic Sources concept, he was led to investigate first resonant then nonresonant sources of the mechanical type. Resonant sources were abandoned because they operate on the principle of the resonating gas bubble wherein the resonant frequency of oscillation is given by the following relationship:*

$$f = \frac{1}{2\pi R} \left(\frac{k\gamma P'}{\rho} \right)^{1/2}, \quad (1)$$

where

- f = resonant frequency in Hz
- R = linear dimension of bubble in cm
- k = number of order 1 dependent on the configuration of the bubble
(for example, k = 3 for a spherical bubble with R denoting the radius)
- γ = ratio of specific heats of the gas at constant pressure and volume
- P' = ambient ocean pressure in dynes/cm²
- ρ = density of gas in g/cm³.

Equation (1) shows that a resonant source's linear dimension, R, must be large – thus the source must be relatively expensive – when the design frequency is low and the depth of operation is great. Also, small excursions of the source in depth change the pressure, P', as well as the source operating frequency, f. (Or if f is forced to remain constant, changes in P' generally cause the source to operate off resonance, with corresponding large changes in the source's radiated power level.)

All these problems can be avoided by going to a nonresonant type of source. Therefore, the nonresonant acoustic projector design concept shown in figure 1 was formulated, and the NRAP project was sponsored by NOSC management.**

During the initial phase of the design effort the author concluded that the approach shown in figure 1 would entail overly large aerodynamic windage losses. A suggestion by FR Abbott concerning the MK VI minesweeper source then led to a cam-type design (fig 2). Further work showed, however, that this system would require an unduly expensive cam plus large, expensive cam followers. GO Pickens and JM Walton had independently suggested that a flat linkage system driven by an eccentric might do the job. However, all such systems apparently needed a sliding element, which would be energetically lossy as well as somewhat unreliable in operation. LE McKinley then suggested that the Walschaert valve gear (for old-time steam locomotives) be looked into, and this quest resurrected the Baker modification of the Walschaert system. Finally, a modification of the Baker system in turn became the basis for the design that was used successfully in the project.

*See, for example, NAVMAT P-9675, Physics of Sound in the Sea, p 462.

**Other low-frequency nonresonant sources exist, but none combines all the advantages of this one so far as the author is aware.

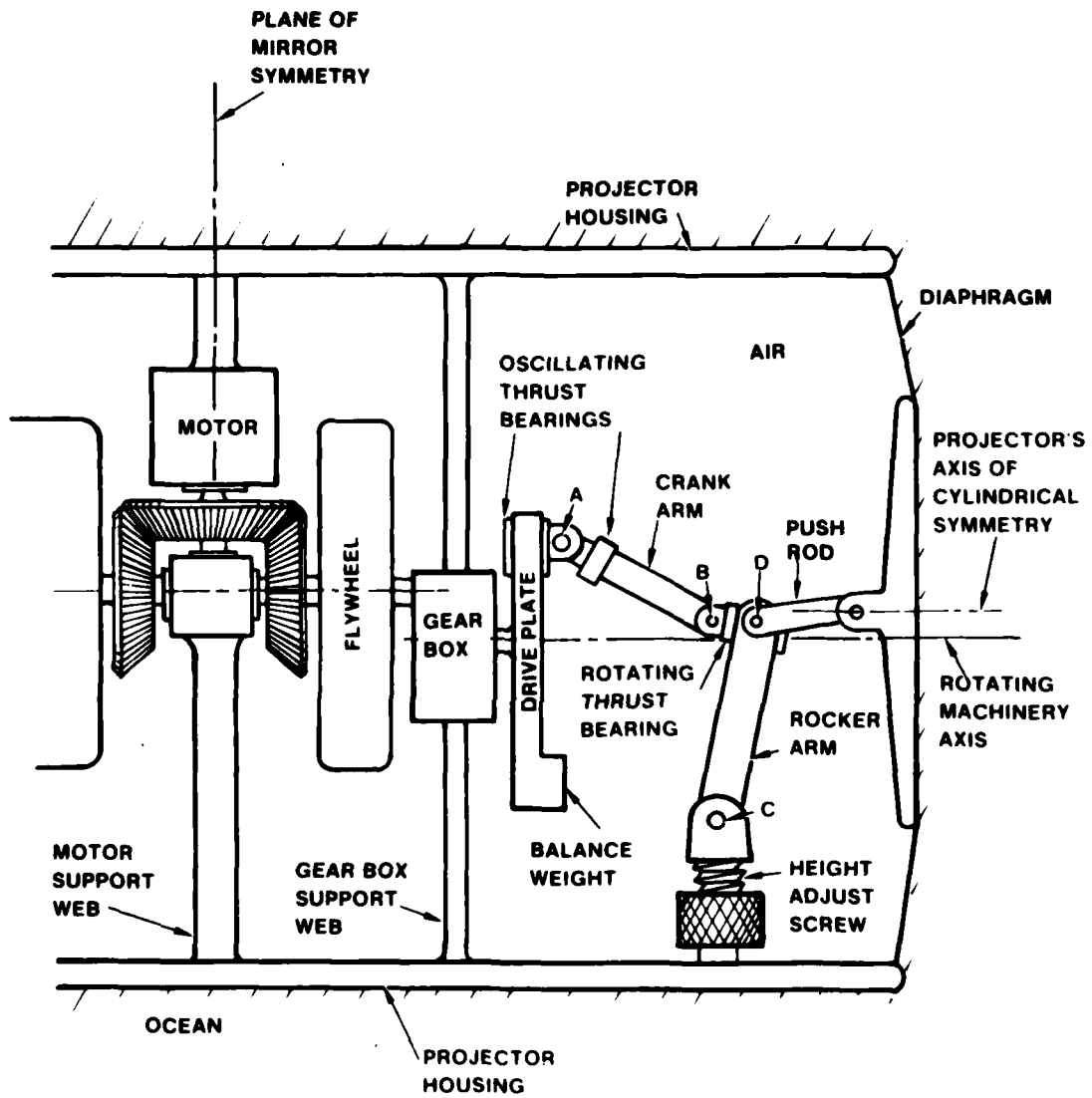

NOTE: FLYWHEELS COUNTERROTATING TO AVOID GYROSCOPIC EFFECTS

Figure 1. First conceptual design for NRAP.

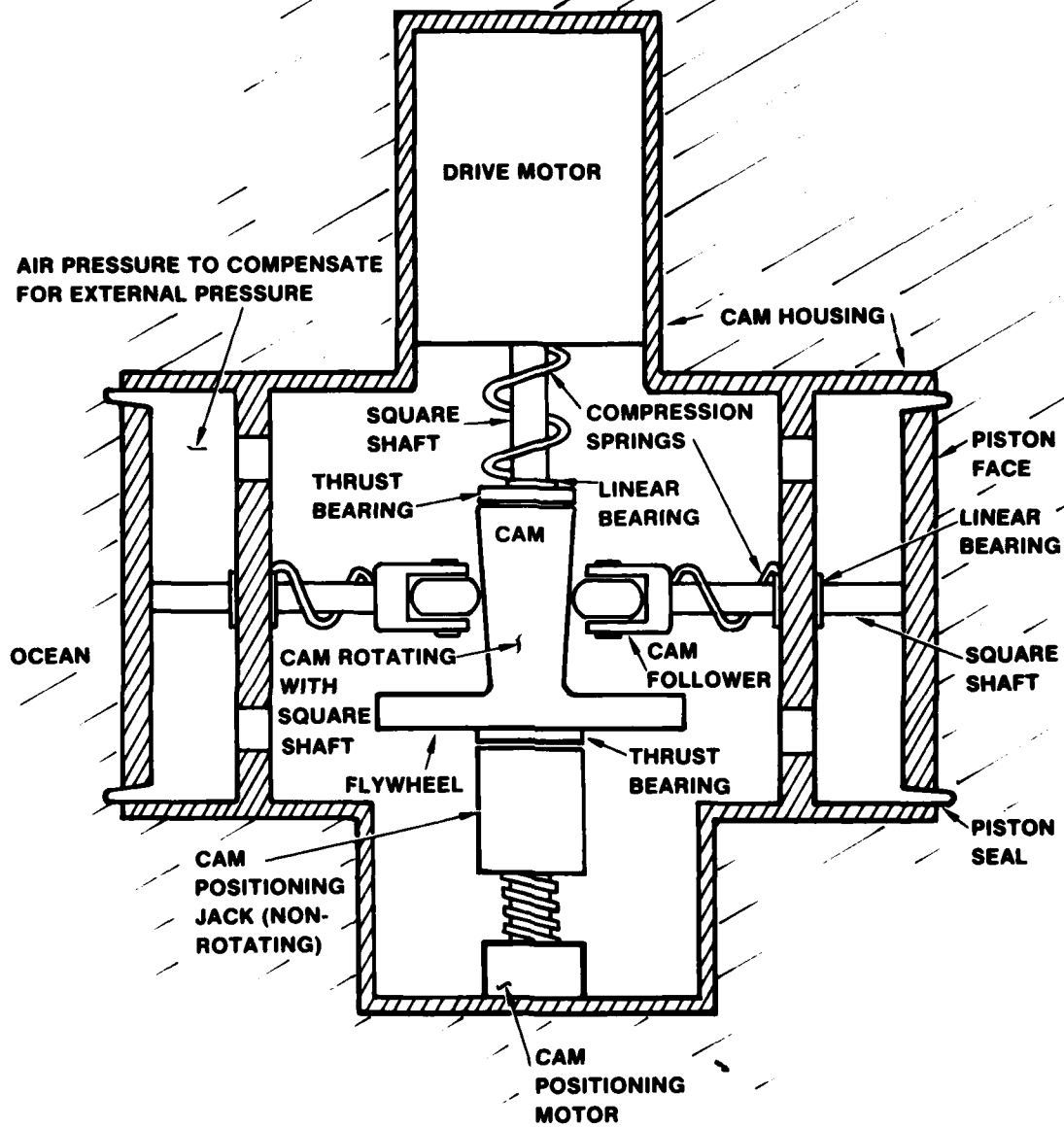

Figure 2. Second conceptual design for NRAP.

DESCRIPTION

In the NRAP (fig 3), a low-power, efficient, dc series-wound electric motor drives one or more pistons by means of an adjustable linkage system. The pistons all operate together to change the projector's volume in the breathing mode of oscillation. Up to six or eight pistons can be accommodated on a single rocking cross arm, and several such arms can be ganged on a single shaft. The unit described here, however, employs only two opposed pistons. Since the operating frequency of the rotor and pistons varies with the voltage applied to the motor, the source can be made to generate either a constant frequency or a frequency-modulated signal as desired. Applying voltage to the screw adjustment motor moves the amplitude adjustment link to control piston oscillation amplitude.

If point F on the amplitude adjustment link is fixed at the location shown in figure 3, point C is forced to oscillate along arc G as the rotor turns. This makes point D oscillate along arc I, which is centered on the fixed point E. Since the rocking cross arm is forced to rock with near-sinusoidal angular motion about its fixed point E, the pistons are driven in and out at the rotor turning frequency. If the amplitude adjustment motor is actuated to drive point F into coincidence with point D, arc G swings into coincidence with arc H, which is centered on point D, and both D and the rocking cross arm become stationary even though the rotor continues to turn. If the amplitude adjustment motor is actuated to drive point F to a location between point D and that shown for point F in figure 3, arc G swings

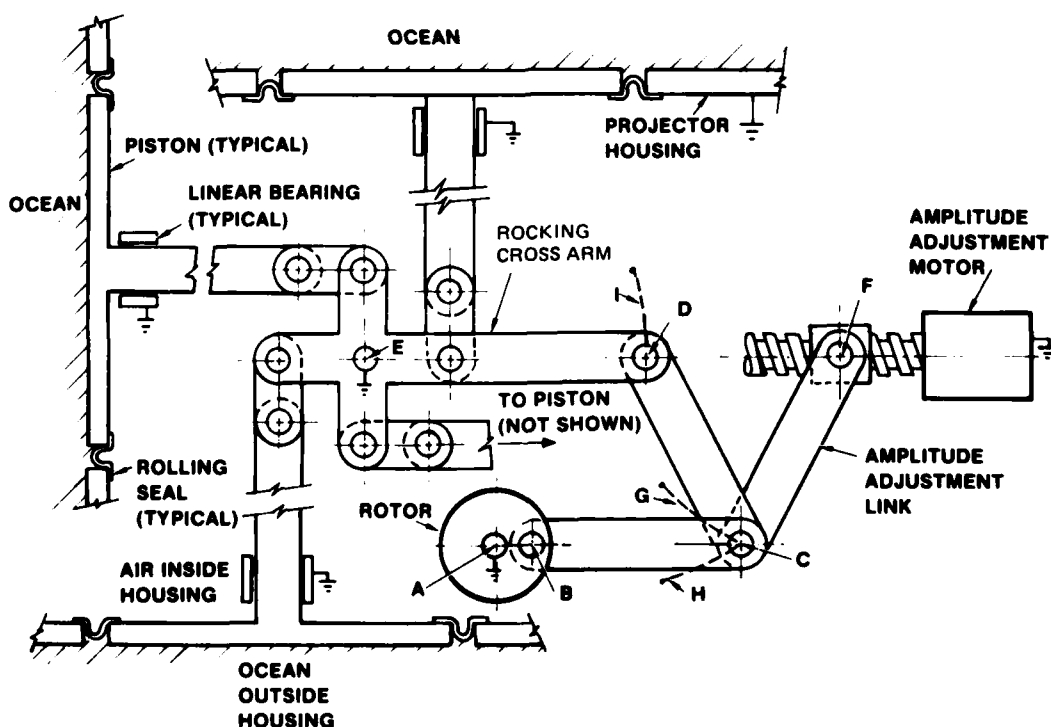

Figure 3. Third conceptual design for NRAP.

into a position somewhere between arc H and arc G shown in the figure, and the amplitude of motion of the rocking cross arm and pistons increases to something less than what it was in figure 3.

Note that both the frequency and the amplitude of piston motion can be adjusted independently or conjointly while the source is in full operation. Changing one without changing the other generally causes the output power of the projector to change – see equation (5).

When the piston amplitude is set to zero, the rotor drive motor can be started for any depth of operation of the projector, since the motor then has to overcome only the friction of the internal bearings. Once the rotor is turning, the piston amplitude can be adjusted as desired, without difficulty.

When the amplitude adjustment link has been set to a definite location, the pistons are coupled tightly to the rotor. Therefore, the frequency of the piston motion is determined only by the rotor turning rate. Also, the link amplitudes of motion are determined only by the rotor-linkage geometry. As a result, both frequency and amplitude of the piston motion are independent of the pressure of the air inside the housing and the pressure of the ocean outside the housing. Therefore, changes in the operating depth of the projector do not change either the frequency or amplitude of piston motion.

Consequently, the system can be designed to operate in a pressure compensated housing. A nominal overpressure such as 5 psi can be maintained within the housing, thus eliminating the need for heavy (hence expensive) housing walls. If a leak develops in the housing, the overpressure inside prevents intrusion of ocean water into the interior. The overpressure also prevents bearing play or "backlash," which would produce distortion of the output wave form and energy loss in the piston drive train. Additionally, the overpressure prevents reversal of the rolling seals during operation.

Since the amplitude of piston motion is determined by the location of the amplitude adjustment link and the frequency of motion is determined by the rotor speed, the NRAP projector becomes in effect a "standard source" whose acoustic output power level is controlled only by the projector's operating parameters together with the intrinsic parameters (density and sound velocity) of the ocean medium. Since small excursions in the operating depth of the source do not influence the latter quantities to any great degree, the NRAP does not require complex or precise calibration with exterior devices such as calibrated hydrophones located at well-measured distances from the source, etc.

Moreover, the acoustic intensities radiated at the fundamental as well as the higher harmonic frequencies can be calculated directly from the values of the linkage parameters used in the projector.

Important in the concept of the NRAP is the flywheel. This unit is rigidly connected to the rotor and hence to the pistons. Therefore, the high reactive power flow into the ocean during half of each piston cycle is recovered by way of an equal reactive power flow back into the flywheel during the next half of each cycle. As a result, this source has higher efficiency than many types of low-frequency projectors.

Because large peak forces exist in the linkage system under most conditions of operation, the bearing frictions are correspondingly large and all linkage elements must be sized to withstand the peak forces.

For the purposes of this "proof of principle" project, the NRAP was designed to provide an output sound pressure level of 171 dB re $1 \mu\text{Pa}$ at 1 m – about 1 W of acoustic power – at a frequency of 15 Hz. The diameters of the pistons were chosen to be 11.25

inches, and the diameters of the mating apertures for the pistons were chosen to be 12 inches. The annular gap between each piston and its mating aperture is sealed with a rolling rubber seal (fig 3). The front of the seal advances just half as far as its piston. Thus if the piston advances a distance s (in cm), the volume change produced in the projector (in cubic centimetres) is

$$(\pi/4)D_p^2s + (\pi/4)(D_a^2 - D_p^2)(s/2), \quad (2)$$

where

D_p = piston diameter in cm
 D_a = aperture diameter in cm.

The term on the left is the volume change produced by the piston's advance, and the term on the right is the volume change produced by the advance of the seal. The volume change expressed by equation (2) can be equated to that produced by a tight-fitting piston of "effective" diameter D_e , hence the equation

$$(\pi/4)D_e^2s = (\pi/4)D_p^2s + (\pi/4)(D_a^2 - D_p^2)(s/2). \quad (3)$$

Solving this equation for D_e ,

$$D_e = \left[(D_p^2 + D_a^2)/2 \right]^{1/2}. \quad (4)$$

Inserting the values for D_p and D_a yields an effective diameter of 11.631 inches for this projector.

The formula for the average acoustic power, P , from a source with small circular pistons operating at low frequency in the sinusoidal breathing mode is as follows:*

$$P = 2\pi^3(\rho/c)f^4(A \cdot s)^2, \quad (5)$$

where

P = average radiated acoustic power in ergs per second
 ρ = water density in g/cm^3
 c = velocity of sound in the water in cm/s
 f = operating frequency in Hz
 A = total piston area in cm^2
 s = amplitude (half the peak-to-peak excursion) of each piston's motion in cm.

Inserting the values for the present two-piston NRAP operating in fresh water (corresponding to the case at the Transdec or Lake Pend Oreille facilities) yields $s = 0.197$ inch for $P = 1$ watt ($= 10^7$ ergs/s), $\rho = 1.00$ g/cm^3 , $c = 147\,950$ cm/s, $f = 15$ Hz, and, for total piston area, $A = 1371$ cm^2 ($= 2(\pi/4)(11.631 \times 2.54)^2$).

*See, for example, Acoustics, by J.L. Hunter: Prentice Hall, 1957, p 147.

Figure 4 shows the completed NRAP in an oversize housing with walls chosen to be much thicker than necessary. The rotor drive motor is a dc motor rated at 1/12th horsepower. It drives the flywheel, housed in a flat cylindrical enclosure, by means of a V-belt and pulleys. The projector has two opposed pistons.

Figure 5 shows the underside of the horizontal plate seen at the middle of figure 4. One piston push rod with its piston face removed is seen passing through its linear bearing at the left. In the center of figure 5 is the rotor partially hidden under the eccentric drive pin labeled B in figure 3. In the foreground of pin B is the pin labeled C in figure 3, and to the right of pin C is the pin labeled F in figure 3. Prominent at the right of figure 5 is the amplitude adjustment motor and its associated screw drive assembly for moving pin F. Below and between the screw drive assembly and pin B can be seen part of the rocking cross arm. The linear transducer provides a precise electrical indication of the location of pin F and hence of the amplitude of piston motion.

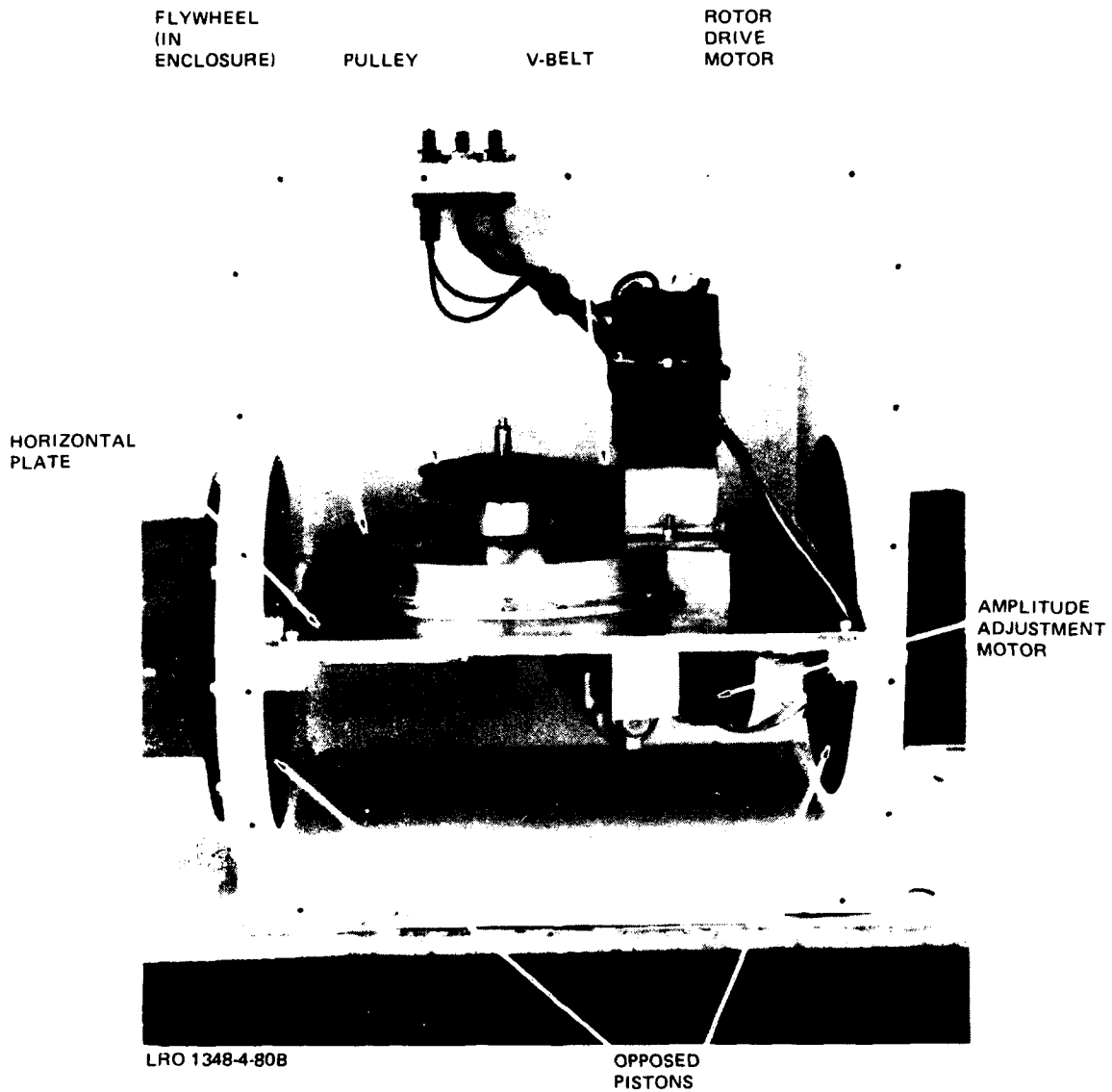

Figure 4. Two-piston working model with one side of housing removed to show interior mechanisms.

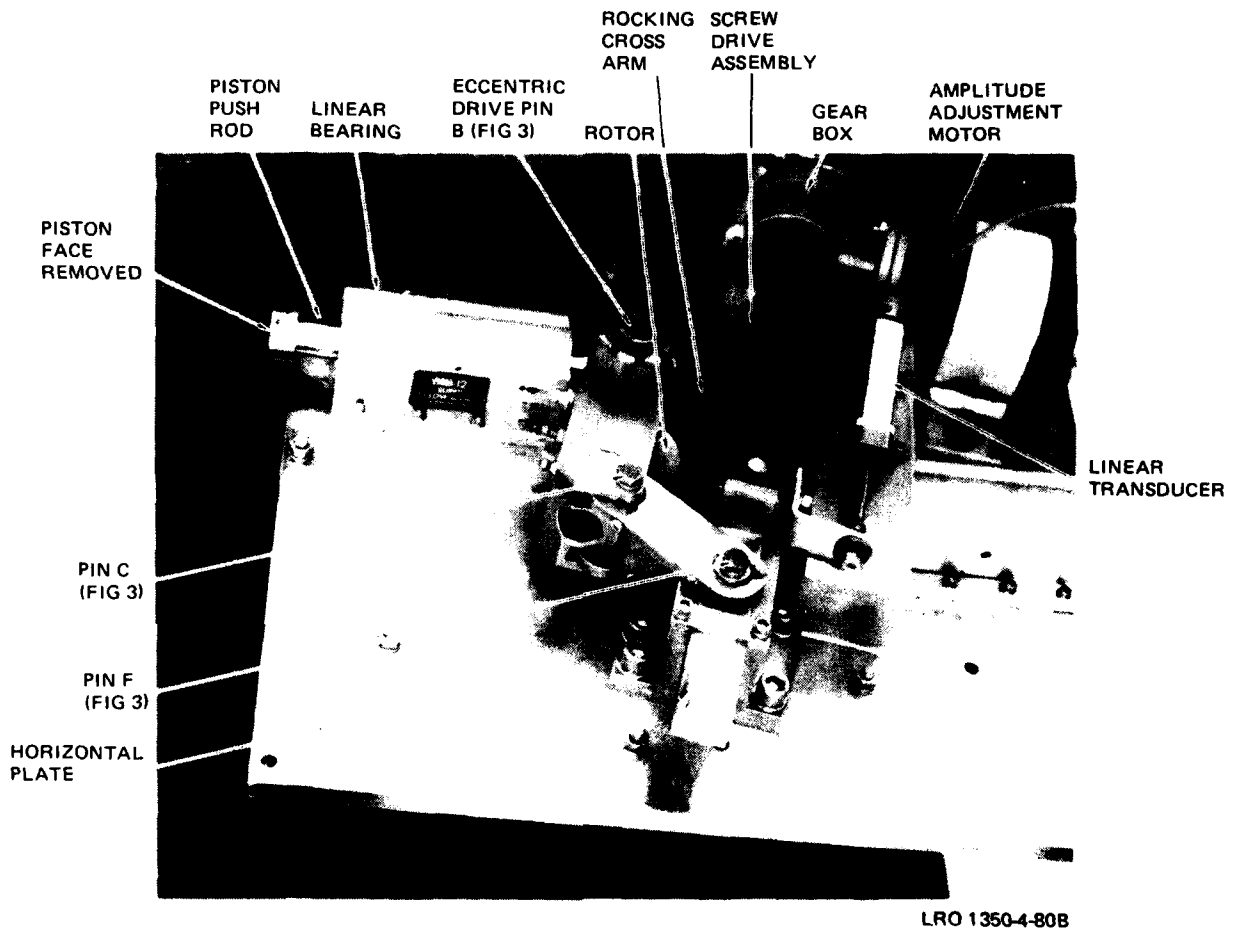

Figure 5. Underside of horizontal plate, showing the linkages.

TEST RESULTS

BENCH TESTS

Figure 6 is a calibration curve that relates the electrical indicator resistance to peak-to-peak piston throw (twice the amplitude of piston motion).

Shakedown tests proceeded without problems. The V-belt (fig 4) was judged less efficient than had been expected and was replaced by a Berg "Min-E" chain with matching sprockets.

TRANSDEC TESTS

The Transdec tests went without difficulties. Figure 7 gives the measured output spectrum with the basic NRAP frequency set at 15 Hz, and with the amplitude set at three values of peak-to-peak piston throw: 0.391 inch, 0.124 inch, and 0.039 inch. The air overpressure in the NRAP was maintained at about 2 psi. The calculated sound pressure levels at 1 m for these values (based on a water density of 1.00 g/cm^3 and a sound velocity of 147950 cm/s , as reported by LJ Orysiek, manager of the Transdec Facility) are 170.64, 160.66, and 150.61 dB re $1 \mu\text{Pa}$, while the corresponding values given by the Transdec instrumentation are 173.3, 162.7, and 152.4 dB re $1 \mu\text{Pa}$ at 1 m. The discrepancies are all less than 2.66 dB, which is consistent with the ± 2 dB stated accuracy (from Orysiek) of the Transdec instrumentation, for a measurement taken under the conditions of the test.

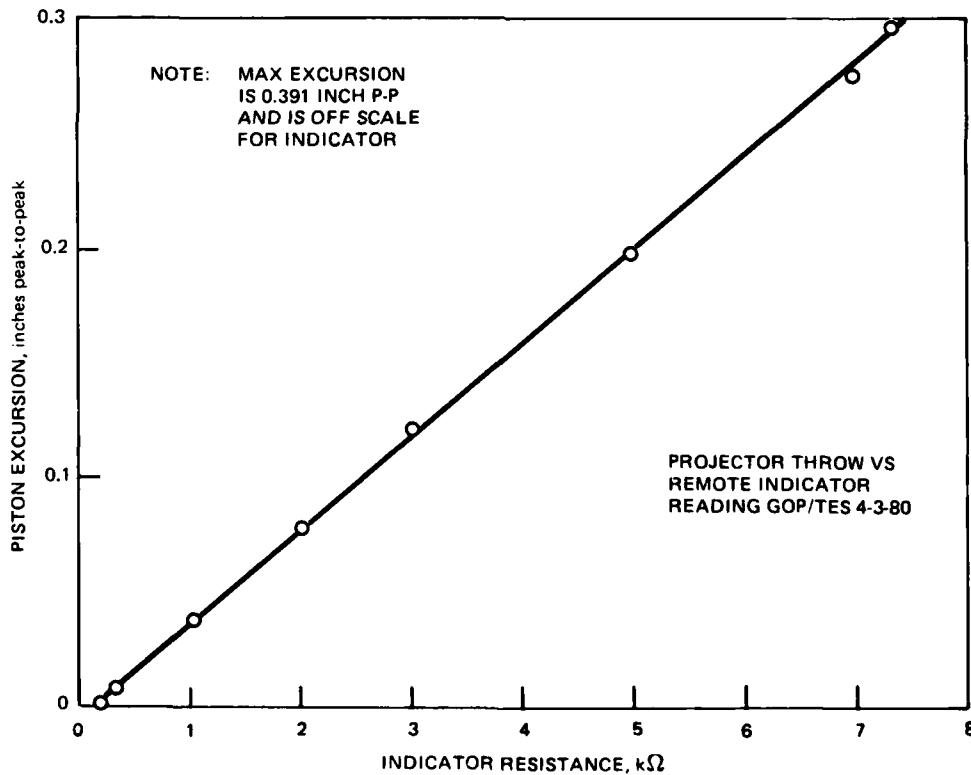

Figure 6. Piston throw vs linear transducer resistance.

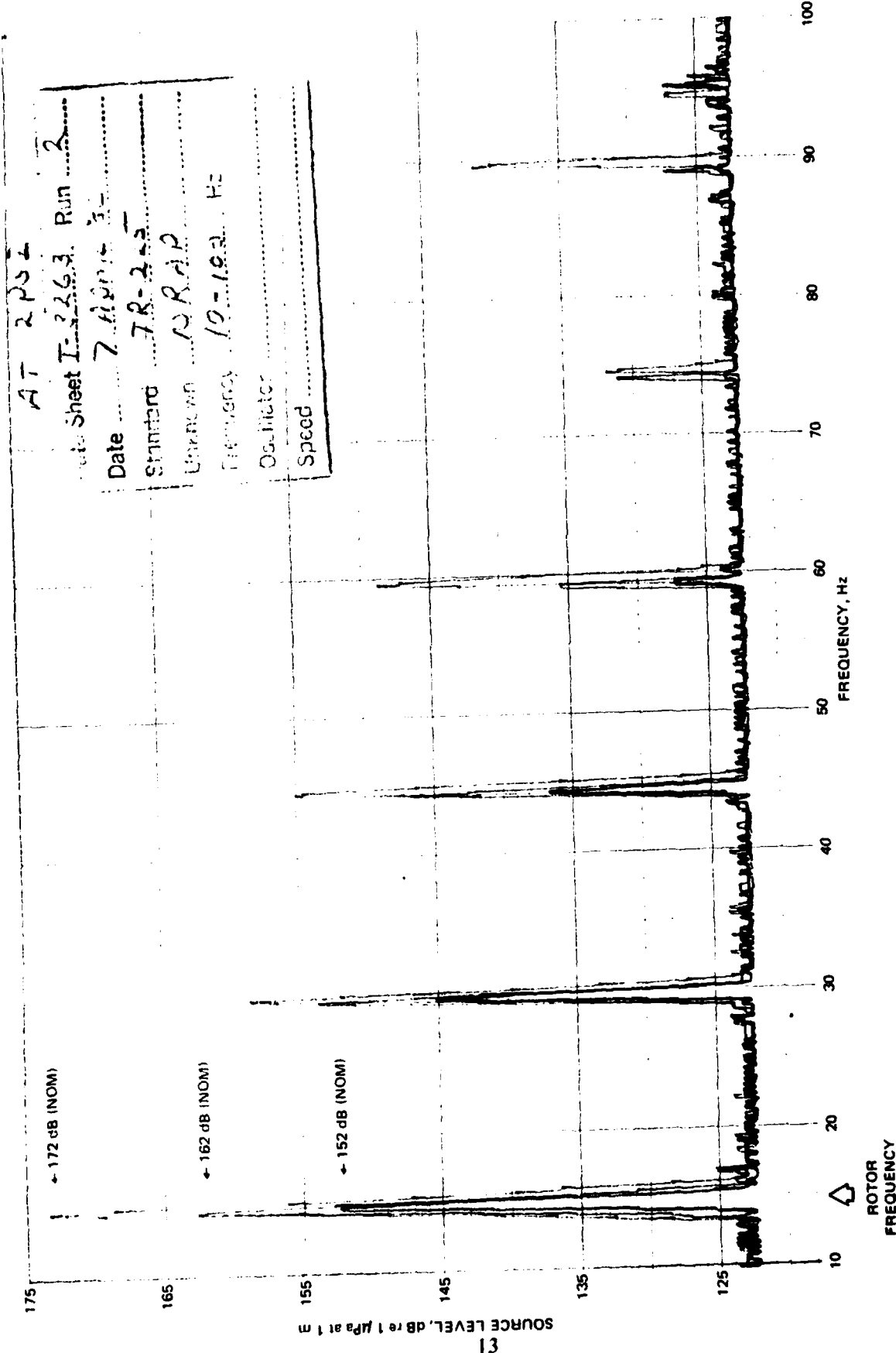

Figure 7. Transdec test run 2 at 15 Hz and 2 psi air overpressure. Peak-to-peak piston throw: red-0.391 inch; black-0.124 inch; blue-0.039 inch.

Figure 8 gives results similar to those of figure 7 except that the air overpressure in the NRAP was maintained at about 5 psi (versus about 2 psi in the first test). No significant changes in performance were detectable from this change of internal pressure.

Figure 9 shows the spectral output when the NRAP was set for (a nominal) zero amplitude of piston motion. The fundamental was down about 45 dB relative to that shown in figure 7. More accurate zeroing can readily be achieved by closed-loop methods, if desired.

Figure 10 shows the output spectra when the NRAP is operated at frequencies of 12, 15, and 16 Hz. The maximum amplitudes vary precisely with the fourth power of frequency, as predicted by equation (5).

LAKE PEND OREILLE TESTS

DL Carson, Code 712, expressed interest in and provided funding for testing the NRAP at a depth of 500 feet at Lake Pend Oreille, Idaho. Therefore, TE Stixrud trucked the NRAP to that facility and conducted a series of tests there. The tests all went without difficulty. Stixrud's report of the tests is attached as appendix A, and details of the sound pressure level calculations are included as appendix B.

PROJECTOR EFFICIENCIES

While no great attempt has been made to measure or improve the NRAP efficiency, general observation of the voltage and current levels required to operate the rotor drive motor under various conditions shows that its efficiency is about 1 to 1.5 percent.

EVALUATION AS A STANDARD SOURCE

On 11 September 1980 the NRAP projector was calibrated at the Navy's Acoustic Calibration Facility (headquartered at NRL/USRD, Orlando, Florida) to evaluate the NRAP as a standard source. The calculated NRAP source level was 170.61 dB re 1 μ Pa at 1 m under the test conditions pertaining, while the measured output level was 169.9 ± 1.0 dB; hence the NRAP capability as a standard source was validated.

THE FUTURE

Since the NRAP design was originally conceived, modifications to the linkage system (appendix C) have made it possible to control the device as follows at suitable points in each cycle when the linkage system velocities momentarily come to zero:

Turn the NRAP from zero to full-on and back again

Reverse the phase of the output signal

Switch the frequency from the fundamental to twice the fundamental and back again.

The switching operations can be accomplished at the zero-velocity points without changing the flywheel velocity or jarring the other parts of the NRAP machinery. These features will make the NRAP suitable for such Navy missions as measuring sound speeds in the ocean, communicating acoustically between distant locations, and obtaining Doppler and other important information about the acoustic channels in the ocean.

The cost of an NRAP unit, in production lots of 100 units, was estimated independently by JM Walton, GO Pickens, TE Stixrud, and the author. The cost estimates lay in the range from \$5,000 to \$10,000.

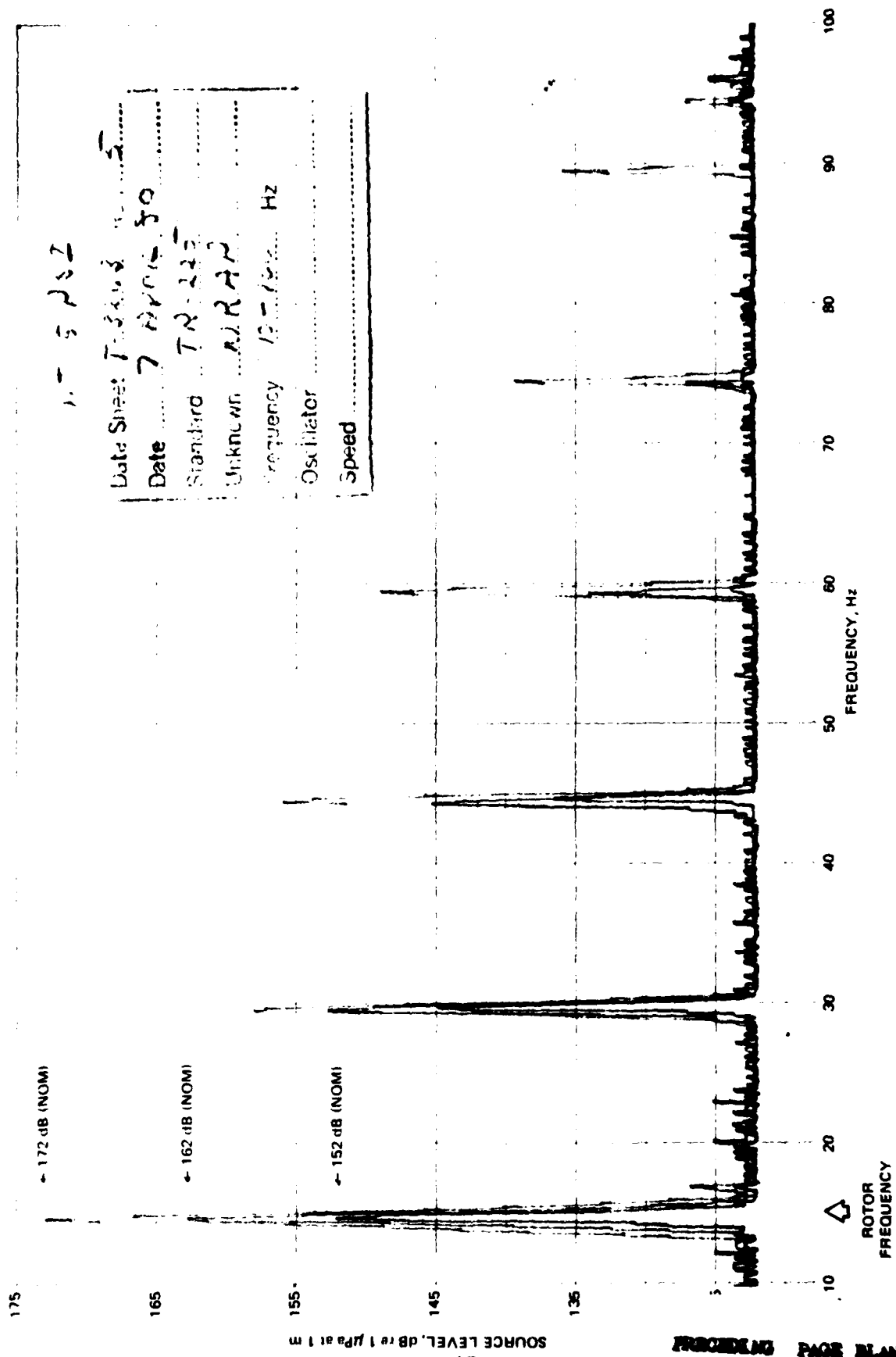

Date Sheet: T-330-3
 Date: 7 APR 50
 Standard: TR-232
 Unknown: A. R. A. W.
 Frequency: 15 Hz
 Oscillator:
 Speed:

Figure 8. Transdec test run 5 at 15 Hz and 5 psi air overpressure. Peak-to-peak piston throw: red—0.391 inch; black—0.124 inch; blue—0.039 inch.

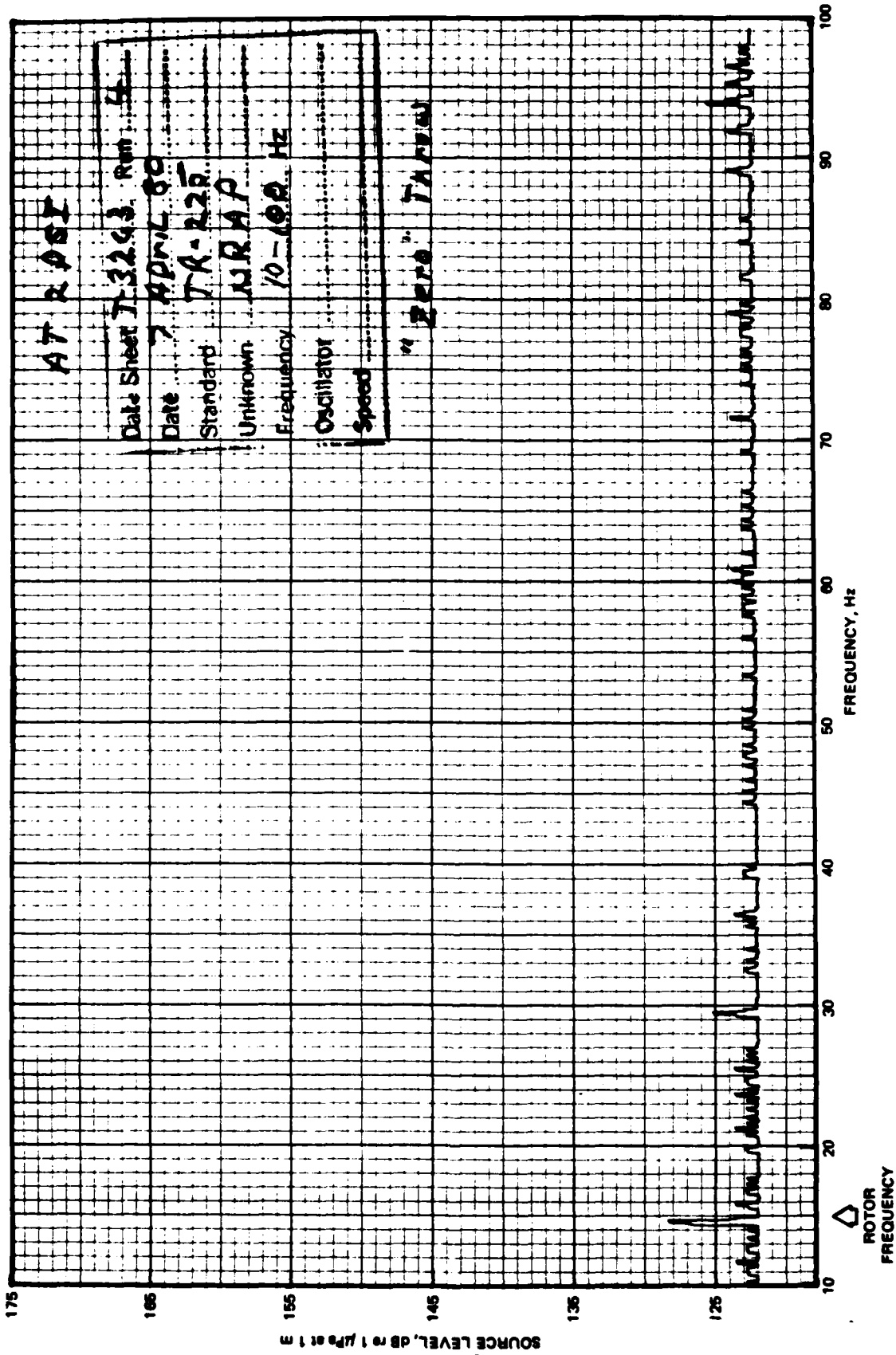

AT R PSI

Date Sheet 7-32-63, Rev. 4
 Date 7 APRIL 60
 Standard TA-22R
 Unknown MRAP
 Frequency 10-100 Hz
 Oscillator
 Speed

"ZERO" TAP

Figure 9. Transdec test run 4 at 15 Hz (but zero throw) and 2 psi air overpressure.

SOURCE LEVEL, DB re 1 μPa at 1 m

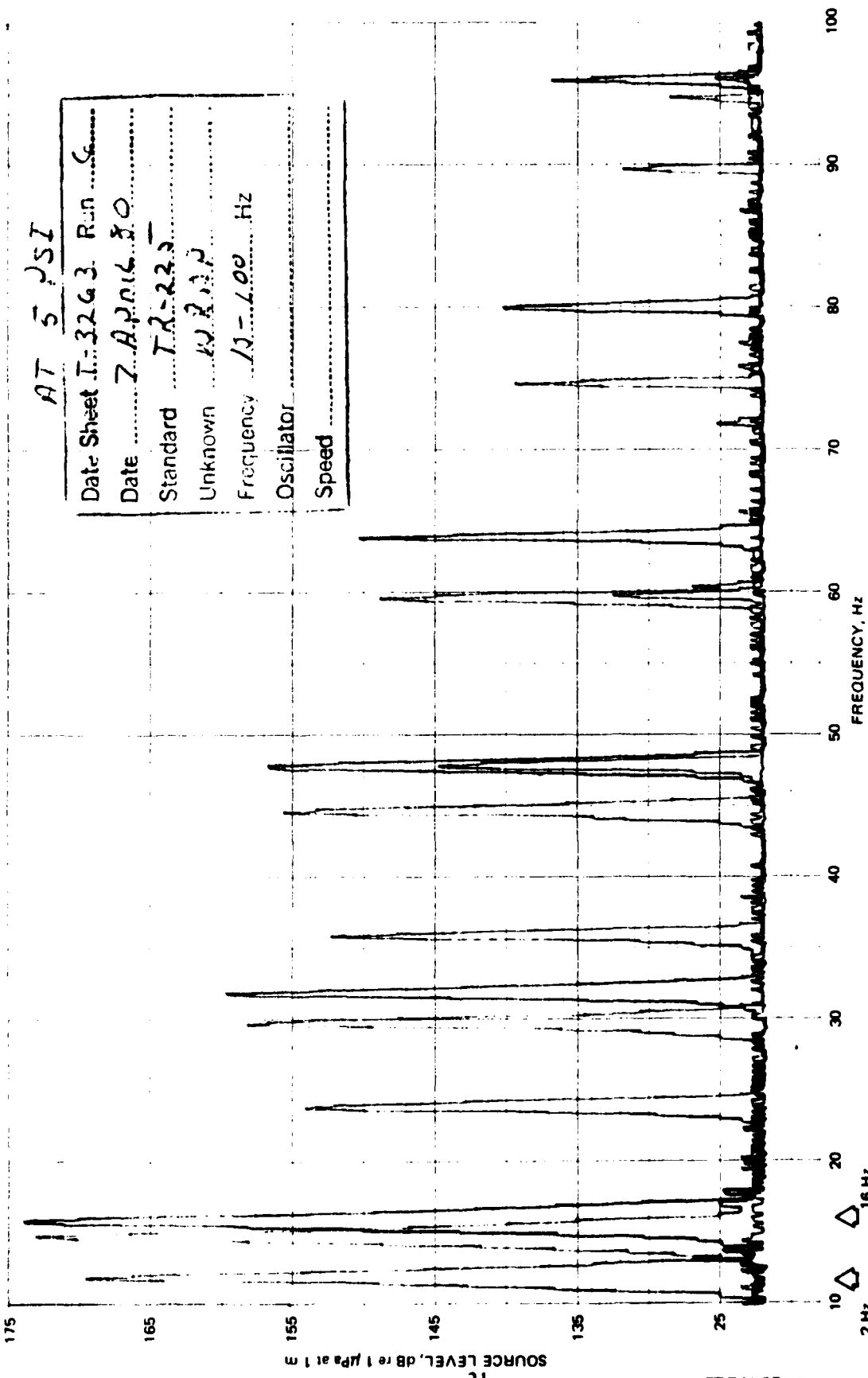

AT 5 PSI

Date Sheet I.: 3263	Run	6
Date	7 APR 68	
Standard	T2-225	
Unknown	WRAP	
Frequency	12-100	Hz
Oscillator		
Speed		

Figure 10. Transdec test run 10 at 12, 15, and 16 Hz and 5 psi air overpressure. Black-12 Hz; red-15 Hz; blue-16 Hz.

CONCLUSIONS

1. The nonresonant acoustic projector was designed, fabricated, and tested without significant difficulties.
2. It met all its specifications, and it proved the principle of a mechanical projector whose operating depth, frequency, and amplitude of piston throw can be simultaneously or independently varied without incurring significant interactions among the variables.
3. The validity of considering the NRAP as a standard source was demonstrated.

RECOMMENDATIONS

1. Apply the nonresonant acoustic projector type of acoustic source to such Navy problems as (a) probing and characterizing the ocean's various acoustic paths, (b) measuring effective horizontal sound speed over ocean paths of Navy interest, and (c) calibrating and measuring the sensitivity of the Navy's ocean surveillance arrays.
2. Promptly develop the "switchable nonresonant acoustic projector" concept for application to significant Navy problems.

**APPENDIX A: HAW-15* ACOUSTIC PROJECTOR TESTS
AT LAKE PEND OREILLE, IDAHO
20-22 May 1980
by
TE Stixrud**

SUMMARY

The newly-developed HAW-15 sound projector was operated at Lake Pend Oreille Facility for 17 hours at a depth of 500 ft and at intermediate depths for shorter periods of time. The unit exhibited no degradation of performance during this evaluation. It required an increase of input power as depth and internal pressure increased in order to offset the increased "windage" loss of the moving parts. Most data were recorded at full power output.

The source level of 171 dB re 1 μ Pa at 1 m at 15 Hz was computed by the volumetric displacement of the pistons and the characteristics of the medium.

INTRODUCTION

The HAW-15 has recently been developed by HA Wilcox, of NOSC, with IED funds. Its two opposed pistons are driven through a unique variable throw mechanism by means of a small electric motor. The motor drives an intermediate flywheel. The flywheel stores energy from the pistons during one part of the cycle and returns it to the pistons during the other part. When the variable piston throw is set at zero, friction is the only system load and the motor-driven flywheel can be started at any operating depth. The acoustic source level can then be set as desired within the design limits. Frequency is controlled by means of the motor speed, 15 Hz being the nominal design value.

The projector satisfied all expectations during the initial verifications at Transdec. This prompted DL Carson of this Center to provide funding for extending the evaluation to the much greater depth of 500 ft and a longer operating time at the Lake Pend Oreille Facility.

PREPARATION

A 550-ft cable was borrowed from Code 5314. Figure A1 shows how this cable was connected.

The transducer was modified as follows:

1. The cover plate was provided with guide pins and handles.
2. A 5-psi differential pressure transducer was installed.
3. The V-belt and pulley drive system was replaced by a more efficient Berg gear and chain drive.
4. Grease seals were installed on the bearings and all bearings were lubricated.
5. Adapters were installed for attaching an air tube for N₂ pressure compensation and for attaching an oil tube from an external oil bladder to the internally mounted pressure transducer.
6. Two adapters to couple nitrogen flasks to the scuba regulator were made.

*In this appendix the subject nonresonant acoustic projector is referred to as Model HAW-15.

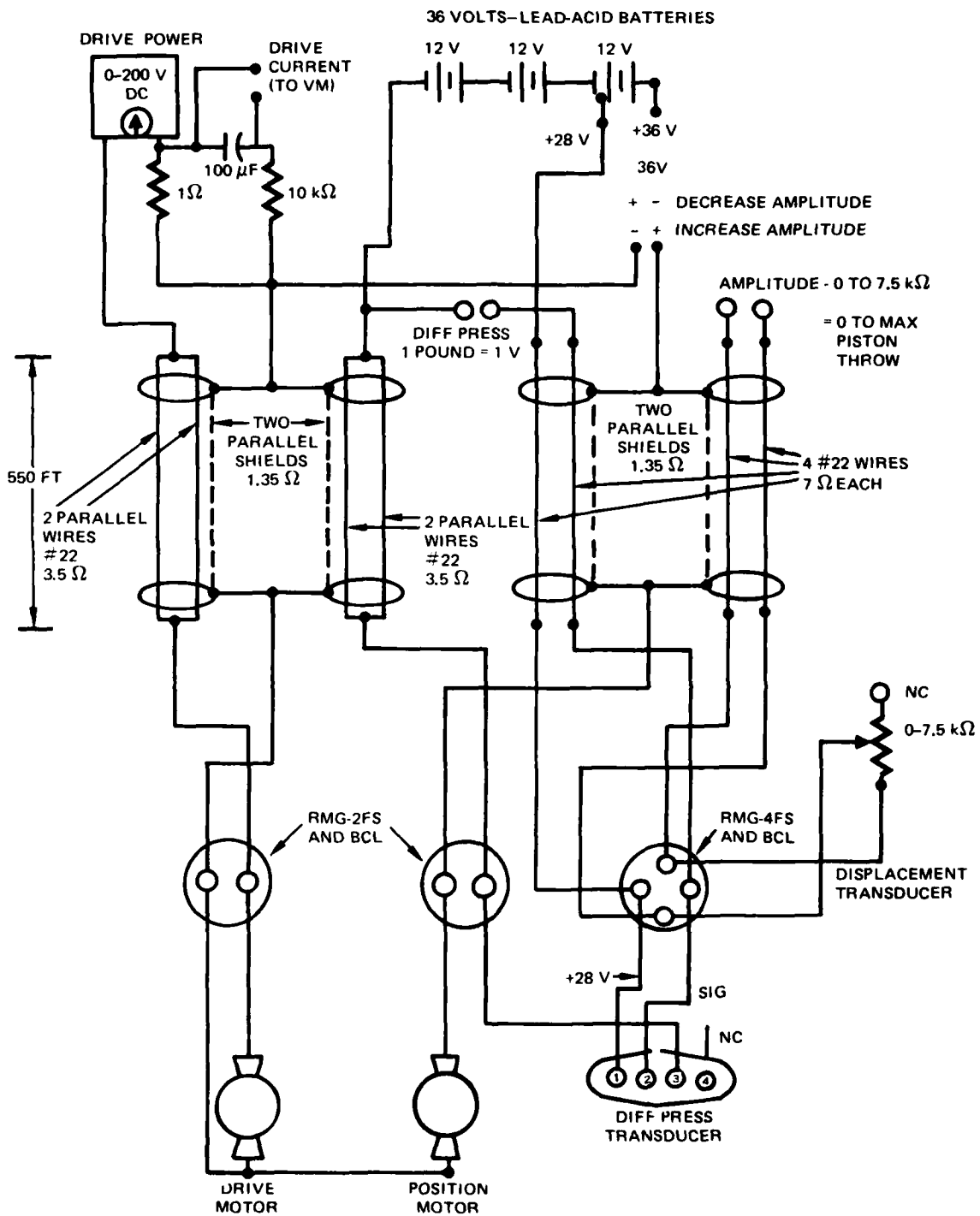

Figure A1. Electrical connections.

Figure A2 shows the pressure compensation system. N_2 was chosen as the pressure compensating gas to avoid oxidation of motor brushes and other electronic components.

Two 225 ft³ nitrogen flasks were borrowed and a scuba regulator and bleeder valve were purchased. The two back-to-back check valves, installed in parallel, were spring loaded to between 3 and 4 psi. They served to prevent the pistons from pumping out the N_2 gas through the scuba valve.

The internal pressure variation during a cycle was estimated as plus and minus 1.4 psi at the 500-ft depth. The maximum inertial force due to the acceleration of the water-loaded pistons was estimated to be equivalent to 2.45 psi on the two piston faces. These numbers led to the selection of plus 5 psi internal operating pressure to ensure that no force reversals would occur on the drive system during operation. The bleeder valve ensured that the internal pressure would exceed the ambient pressure by 5 psi soon after a depth change.

The 5 psi differential pressure transducer was tested and the output voltage was verified to be 1 volt per psi of differential pressure.

A 1-ohm power resistor was installed in series with the drive power and was equipped with a low-pass filter so that the average drive current could be indicated by a digital voltmeter.

Figure A3 shows the arrangement of equipment used for the tests. The transducer was submerged at the end of NOSC Pier B to verify the proper operation of the pressure system.

A pickup truck equipped with a shelter was obtained from Public Works to transport the equipment and author from Naval Ocean Systems Center to Bayview, Idaho and back. This saved about \$1,300 of project funds that would have been spent on shipping, air fare and car rental.

PROCEDURE

The test facility was closed on Monday, 19 May 1980, due to the fallout of volcanic ash from the 18 May eruption of Mt St Helens in Washington state. On Tuesday, 20 May 1980, L Teston, one of the operators, was able to get to work and we loaded the equipment on a boat and transported it to the test barge.

It took about 2 hours to wash the volcanic ash from the work area, and the transducer was then rigged so that the pressure system could be submerged 11.5 feet below the axis of the pistons to supply the 5 psi of internal overpressure when the transducer was submerged.

Figure A4 shows how the monitor hydrophone was suspended on a compliant support 1 metre from the center of the axis between the pistons.

The in-air test was performed with the pistons just out of the water but with the scuba regulator deep enough to supply most of the 5 psi overpressure. The test was repeated with the transducer at 25, 100, 150, and 500 ft. The monitor hydrophone output was recorded on an HP 3960 FM tape recorder, and a spectrum of the monitor hydrophone output was made at each depth.

The drive voltages and currents were tabulated for each depth. After the initial 500-ft test, the transducer was left running throughout the night and into the next morning for a total of 18 hours. Seven spectrums of the monitor hydrophone output were recorded during the operation at 500 ft, along with tabulations of drive voltage and current.

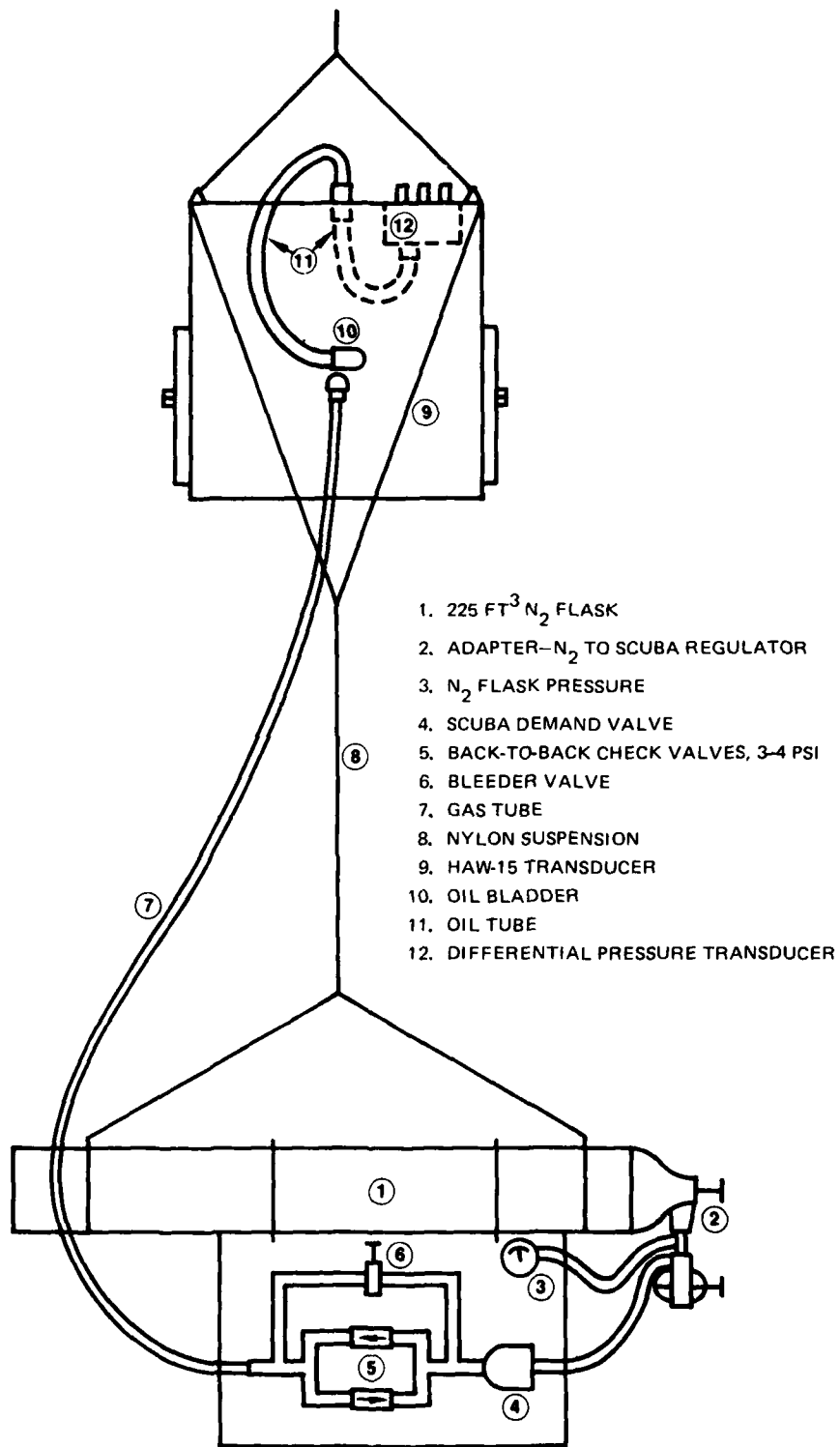

Figure A2. Pressure compensation system.

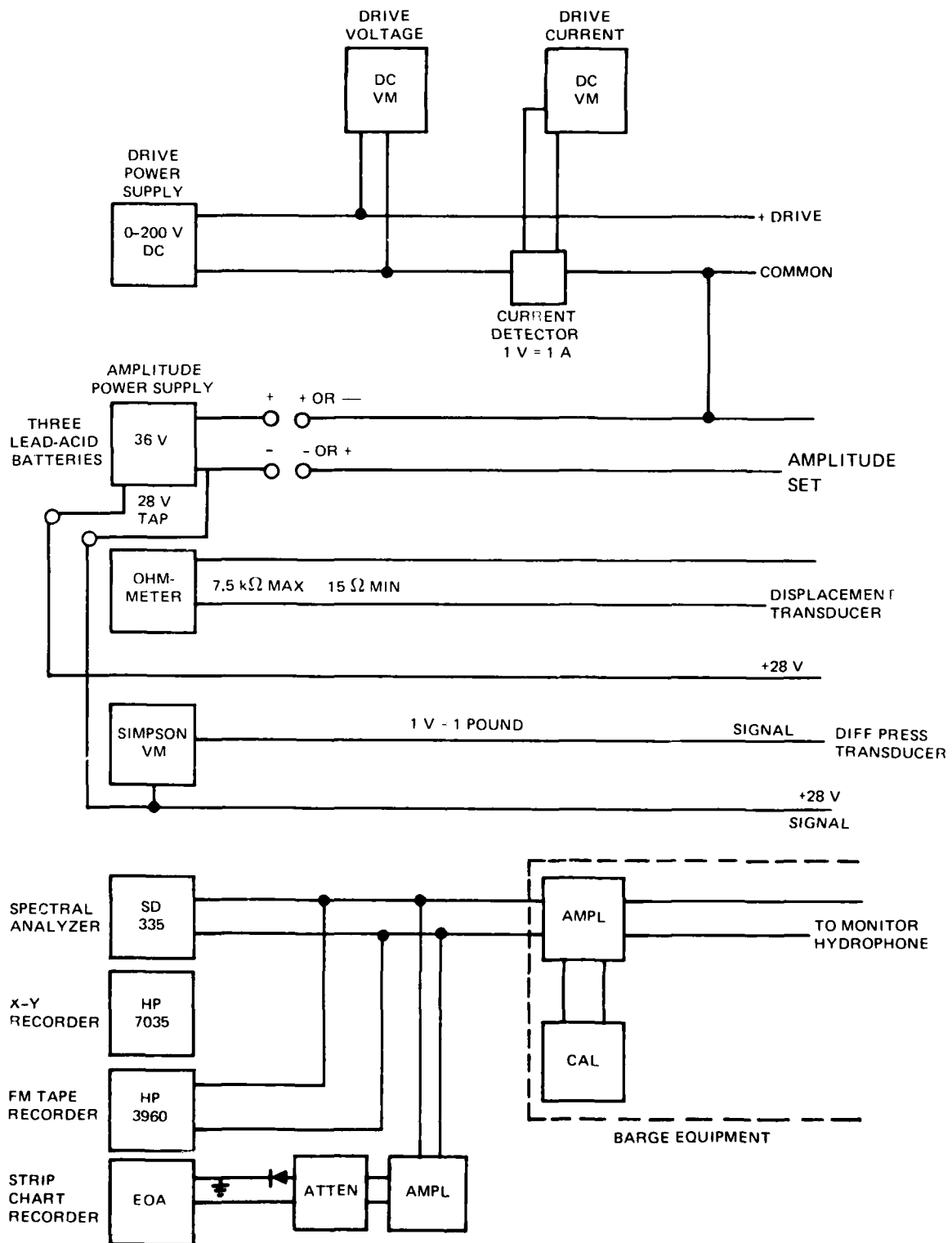

Figure A3. Test setup.

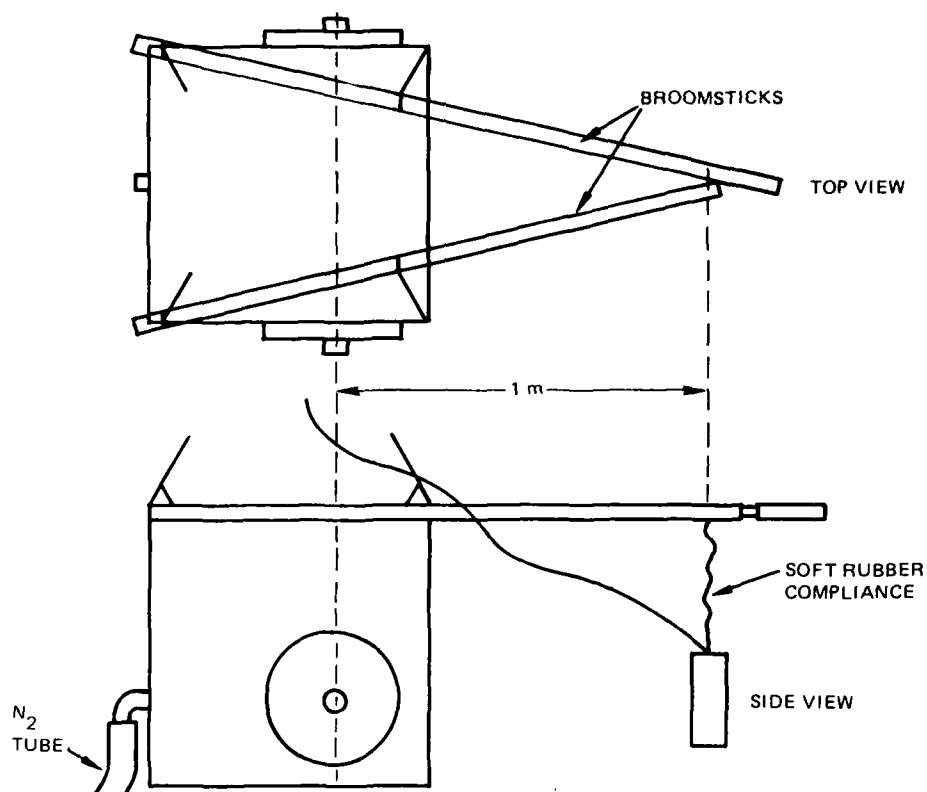

Figure A4. Monitor hydrophone rigging.

The continuity of projector operation was shown by a strip chart recording of the rectified hydrophone signal.

RESULTS

Source Level

MEASUREMENTS. The source level and the frequency spectrum were constant throughout the in-water tests. During the in-air test, the monitor hydrophone was used to set the frequency at 15 Hz. Figure A5 is a composite of two spectrums. The first was made with the monitor hydrophone lying on the wooden supports tied to the projector, and the second was made with the monitor hydrophone hanging from a soft rubber compliance from the same wooden supports. The compliance reduced the coupling between the hydrophone and the projector almost 40 dB in air.

Figures A6 through A9 show that the frequency spectrum and source levels were the same at each depth. Figure A9 is a composite spectrum showing both the usual spectrum at full piston throw and the spectrum when the adjustable linkage controlling the piston throw was set to the extreme minimum position. Figures A10 through A16 show that the 15 Hz line did not change during 18 hours of operation at 500 ft but that some change occurred, particularly in the higher harmonic levels (slightly stronger).

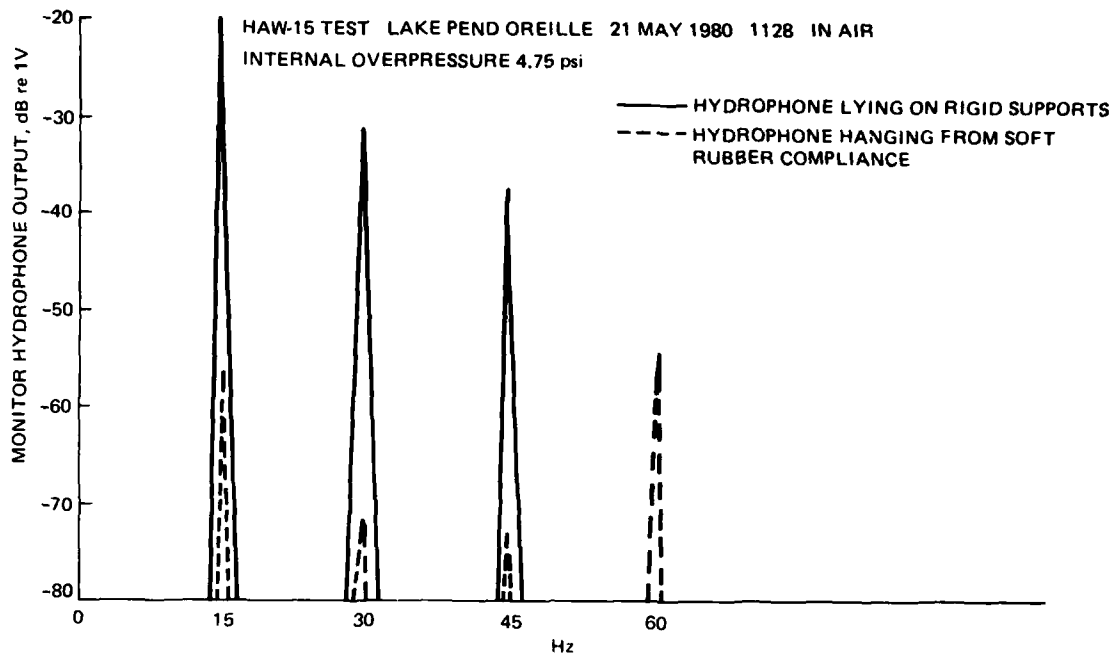

Figure A5. In-air test.

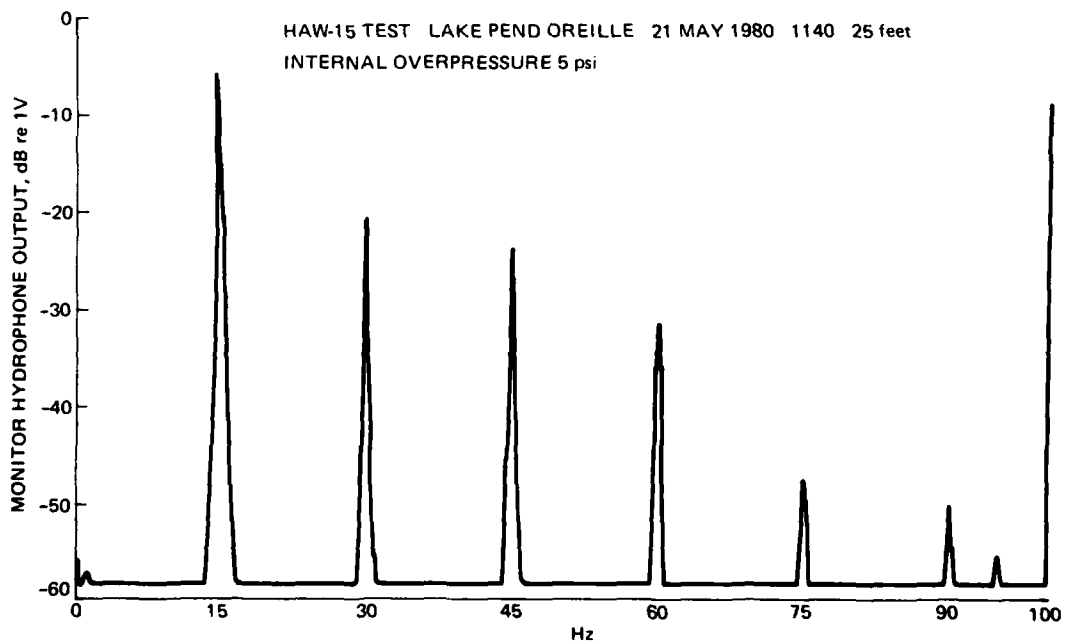

Figure A6. In-water test at 25-foot depth.

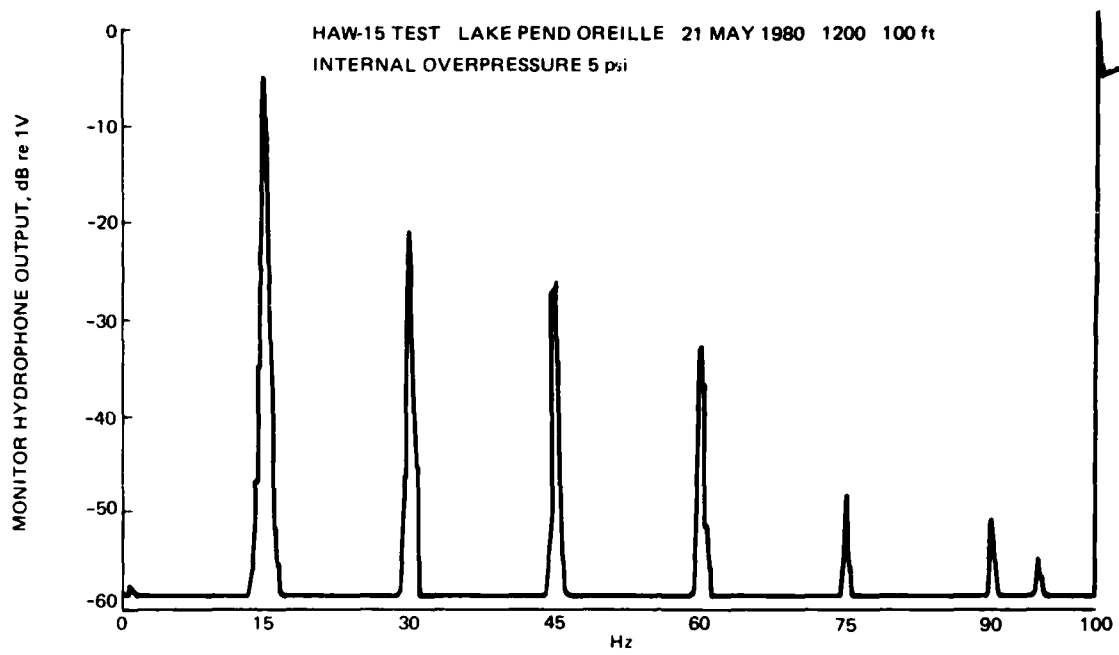

Figure A7. In-water test at 100-foot depth.

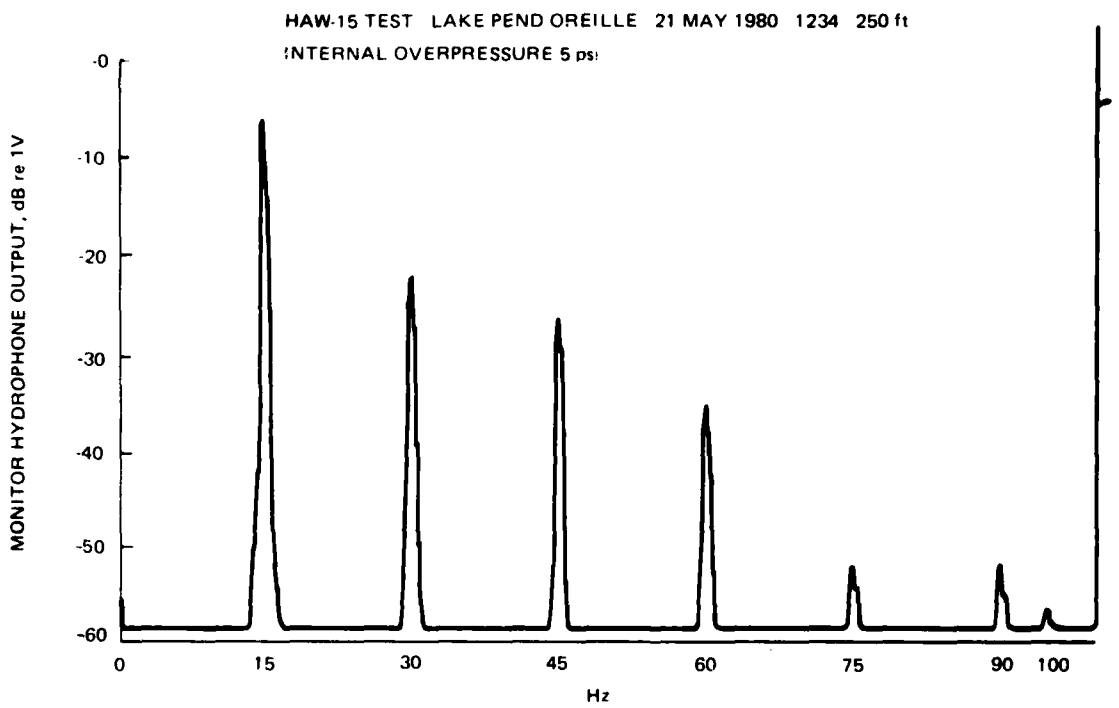

Figure A8. In-water test at 250-foot depth.

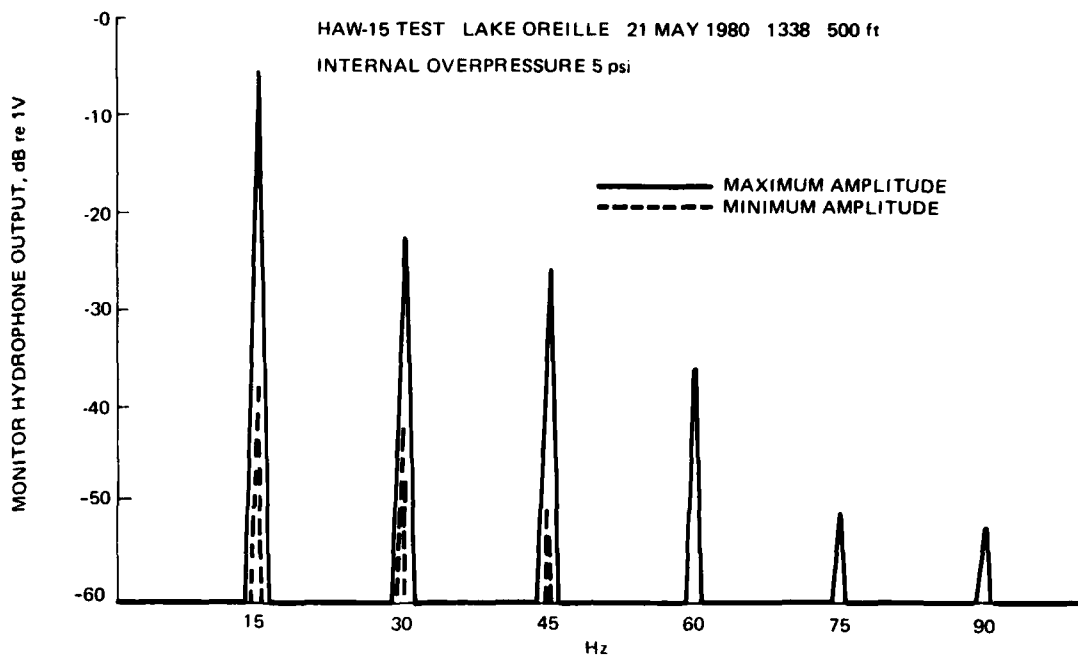

Figure A9. In-water test at 500-foot depth, maximum and minimum amplitudes.

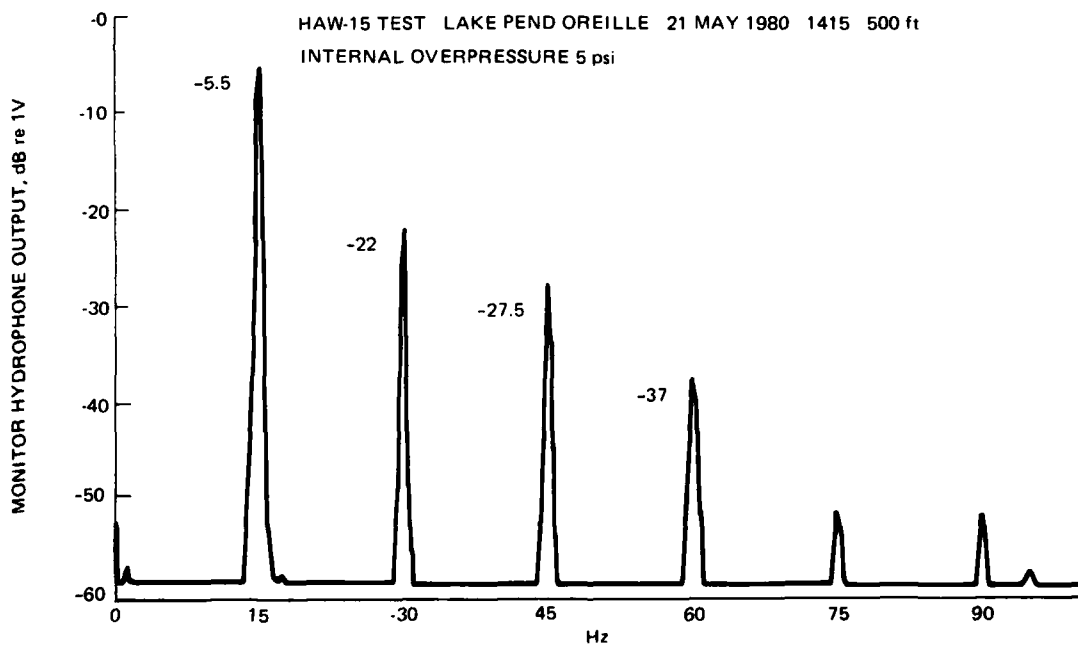

Figure A10. In-water test at 500-foot depth, at test reference time, T_R .

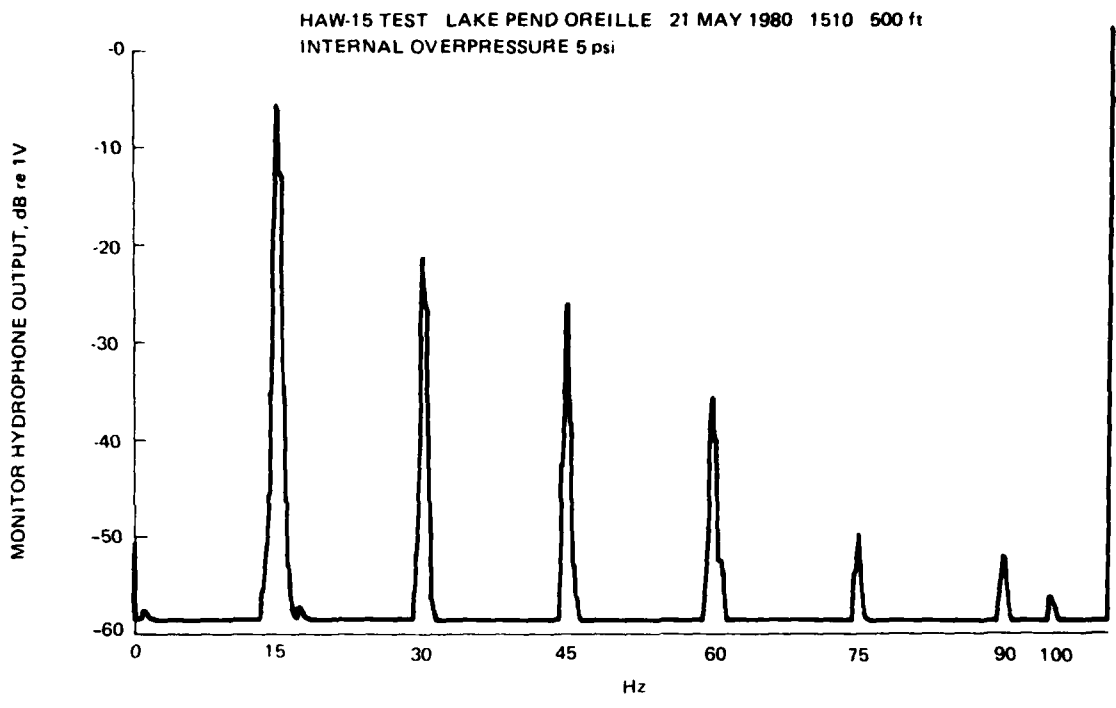

Figure A11. In-water test at 500-foot depth, at $T_R + 55$ min.

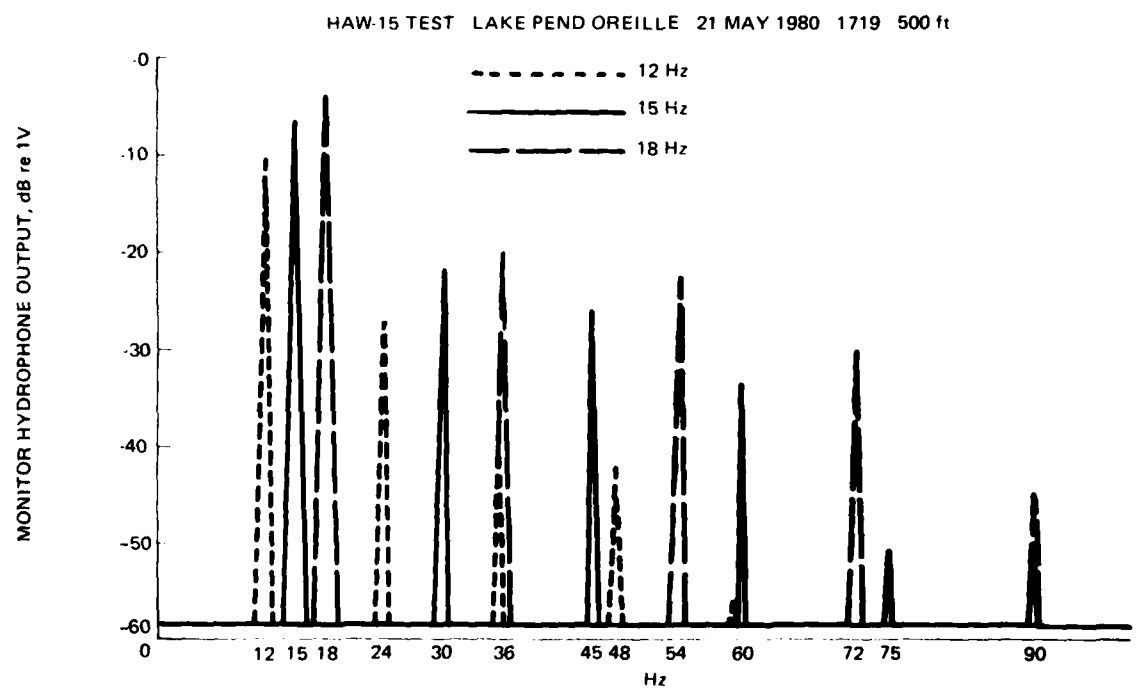

Figure A12. In-water test at 500-foot depth, at $T_R + 3$ h 04 min.

HAW-15 TEST LAKE PEND OREILLE 21 MAY 1980 1830 500 ft
INTERNAL OVERPRESSURE 5 psi

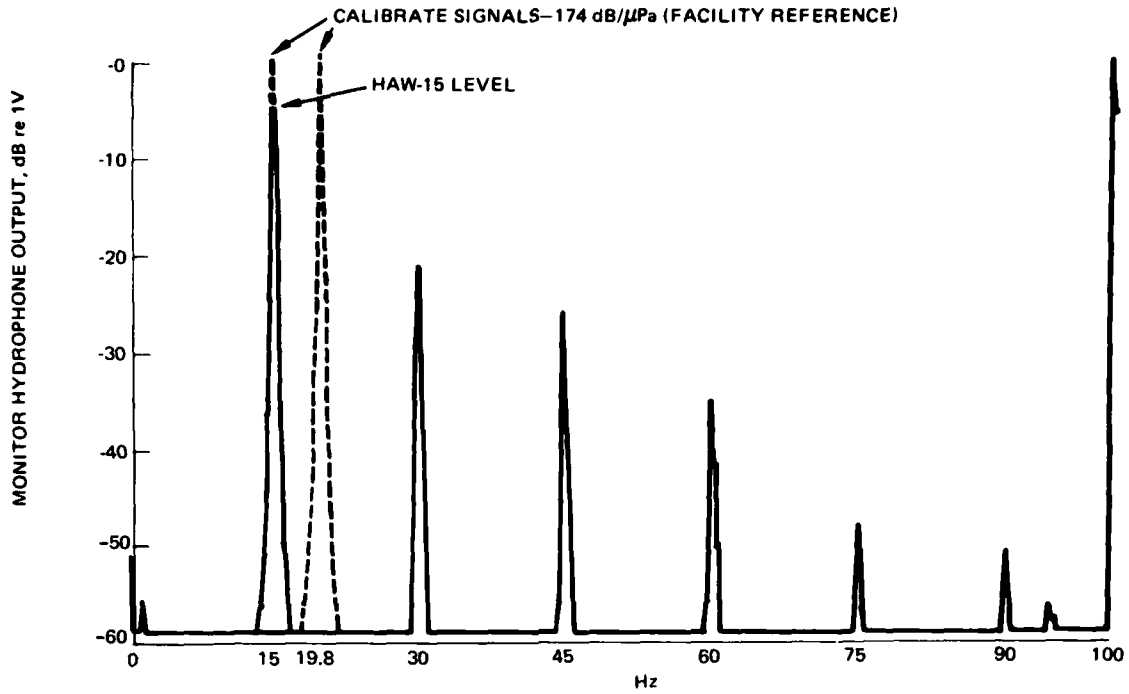

Figure A13. In-water test at 500-foot depth, at $T_R + 4$ h 15 min.

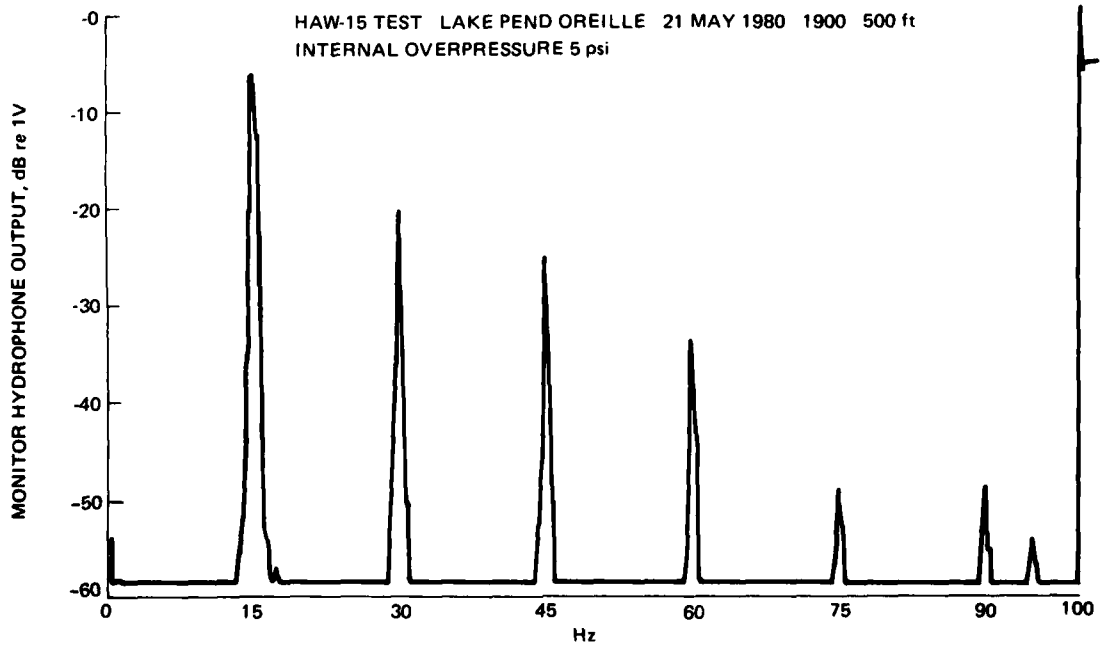

Figure A14. In-water test at 500-foot depth, at $T_R + 4$ h 45 min.

HAW-15 TEST LAKE PEND OREILLE 22 MAY 1980 0725 500 ft
INTERNAL OVERPRESSURE 5 psi

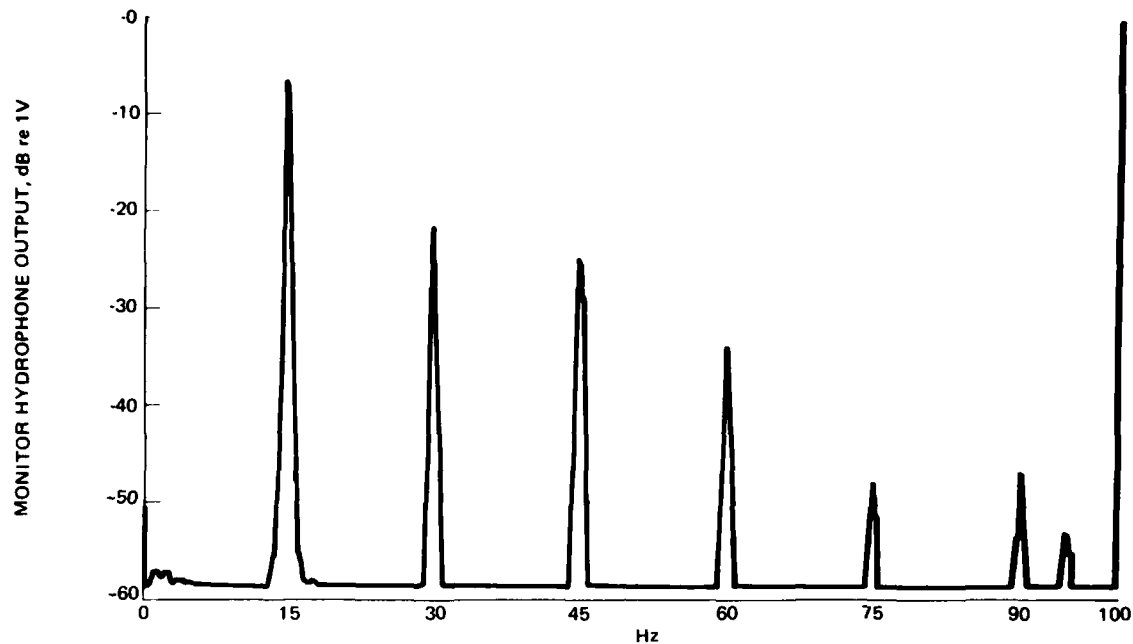

Figure A15. In-water test at 500-foot depth, at $T_R + 17$ h 10 min.

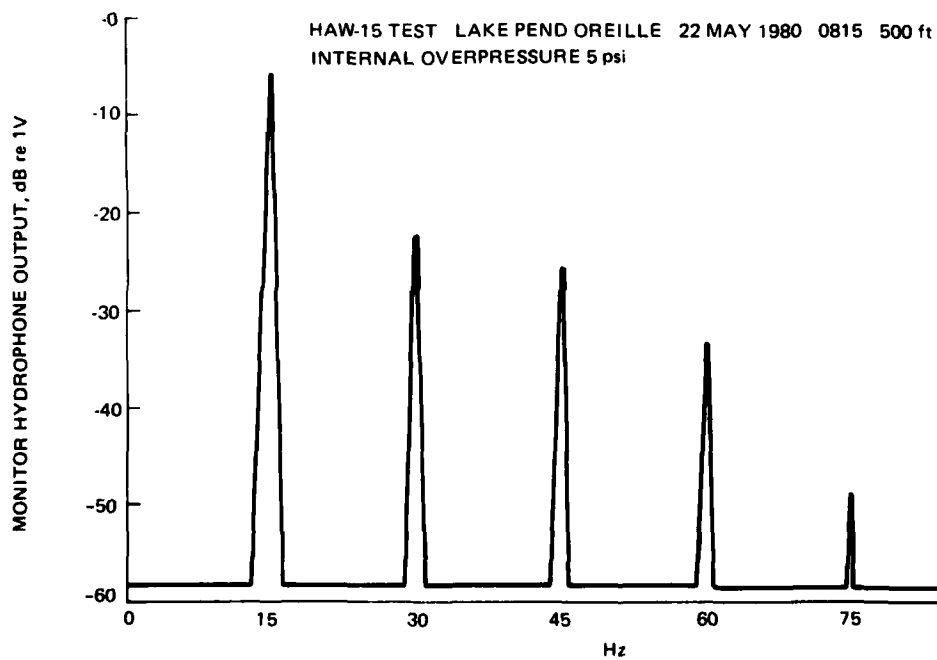

Figure A16. In-water test at 500-foot depth, at $T_R + 18$ h 00 min.

Figure A12 compares the acoustic intensity at three different frequencies. The frequencies, as read on the hydrophone monitor, were set by adjusting the voltage to the drive motor while the piston throw remained at maximum.

Figure A13 is the usual spectrum at 15 Hz with two calibrate signals superimposed. The calibrate signals are intended to represent the monitor hydrophone output when it is exposed to a sound pressure level of 174 dB re 1 μ Pa at 1 m. It can be seen that the 15 Hz calibrate level is 1 dB lower than the 19.8 Hz level. The crew explained that this was due to the diminishing response of the measurement equipment at lower frequencies. The crew established the source level of the HAW-15 projector at an apparent value of 167.5 dB re 1 μ Pa at 1 m. This was based on a digital readout in dB of the amplified monitor hydrophone output compared to the same readout when the 15 Hz calibrate voltage replaced the hydrophone voltage. The crew stated that they had used a hydrophone sensitivity of -203.5 dB re 1 V at 1 μ Pa in their calculations. This sensitivity was based upon a reciprocity calibration at 1 kHz. The same calibrations gave a sensitivity of -206 dB re 1 V at 1 μ Pa at 10 kHz. The crew further stated that they had no way to verify the monitor hydrophone sensitivity at 15 Hz.

SOURCE LEVEL CONCLUSIONS. The HAW-15 transducer radiated a constant source level at all test depths and for an 18-hour period at 500 ft during tests at Lake Pend Oreille. After the tests the full piston-throw amplitude was measured and found to be the same as before the Transdec tests in April. The calculated sound pressure level expected to be radiated at 15 Hz and at the measured displacement was 170.88 dB re 1 μ Pa at 1 m, a little more than 1 acoustic watt of radiated power. The details of the calculations are included as appendix B.

"Windage" Loss

MEASUREMENTS. One of the goals of the test program was to gain insight into the power loss due to the drag of the interior gas (in this case nitrogen) on the various components. Moving components include the motor armature, the flywheel, the linkages leading to the piston faces, and perhaps the pistons themselves. Stationary components which have their effects by retarding the flow of gas caused by the moving parts include the motor stator and housing, the flywheel housing, and to a lesser degree the projector case and structural parts interfacing the gas.

Figure A17 shows the rotor drive motor input power vs depth curve resulting from the following four point measurements:

- A - 104.5 W at 25 ft
- B - 114.0 W at 100 ft
- C - 129.3 W at 250 ft
- D - 148.2 W at 500 ft.

WINDAGE LOSS CONCLUSIONS. In figure A17 the input power vs depth was found to be approximately a straight line. This is to be expected since windage loss is proportional to gas density, which is, in turn, proportional to pressure, hence depth. (There is an additional small increase in density with depth due to the cooler water at greater depths.) In order to separate the windage loss power from the other losses (bearing loss, motor losses and acoustically radiated power), the measured (gross) power loss curve was extrapolated from point A to the -45.5 ft point labeled E. This hypothetical point, calculated by

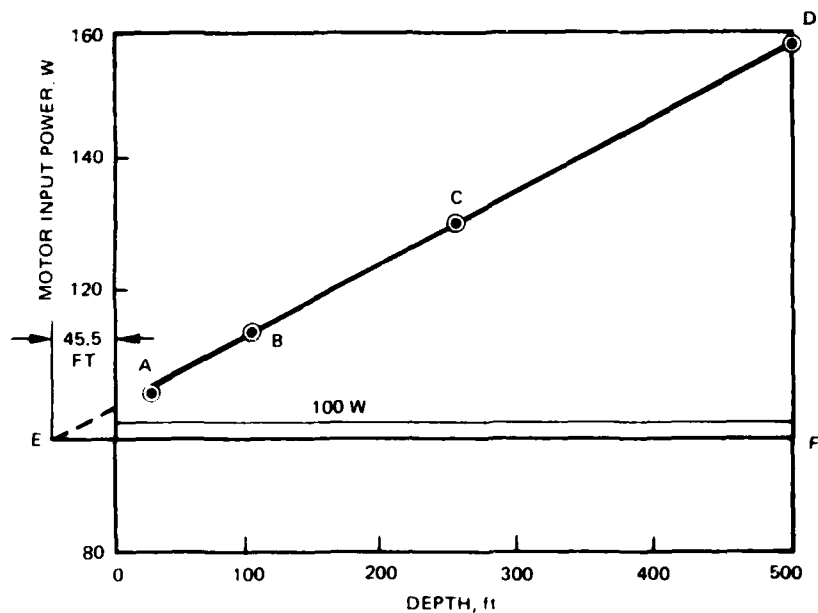

Figure A17. Motor input power vs depth (prior to bearing run-in).

accounting for the 14.7 psi atmospheric pressure and the 5 psi overpressure, represents zero internal gas pressure and hence no windage loss. It follows that the vertical distance from the horizontal line EF to the sloping line at any depth represents the windage losses at that depth, and the value of the ordinate at line EF represents the other losses.

Input Power vs Time

MEASUREMENTS. The input power to the HAW-15 projector decreased appreciably during the continuous periods of operation at the 500 ft depth. Figure A18 is a graph based on the tabulations of input power. The break between 1540 and 1715 is due to a failure of shore power. No tabulations of drive current were made between 1715 and 1830 because of temporary failure of the drive current monitor. Two measurements of input power were made on the morning of 22 May (around 0800). The second measurement is considered more reliable than the first because of a number of distractions, such as changing recorder tape and calibrations, that were occurring simultaneously. The straight line connecting the data between 1900 of 21 May and 0815 of 22 May covers the period when HAW-15 operated unattended.

It was expected that a further drop in input power would be observed when HAW-15 was again operated at the surface, where the windage losses are minimum. On 29 May, therefore, the HAW-15 was operated at NOSC in the air with 5 psi internal overpressure. The initial power input was 93.5 watts, 3 watts less than measured in air at the beginning of the test at Lake Pend Oreille. After 10 minutes the power dropped from 93.5 to 79.4 watts.

CONCLUSIONS ON INPUT POWER VS TIME. The HAW-15 projector required less input power with time during the prolonged tests. The initial rapid drop could be due to decreasing friction as the bearings warm up and the lubricating grease becomes less viscous. This effect might have been evident again on figure A18 if power measurements

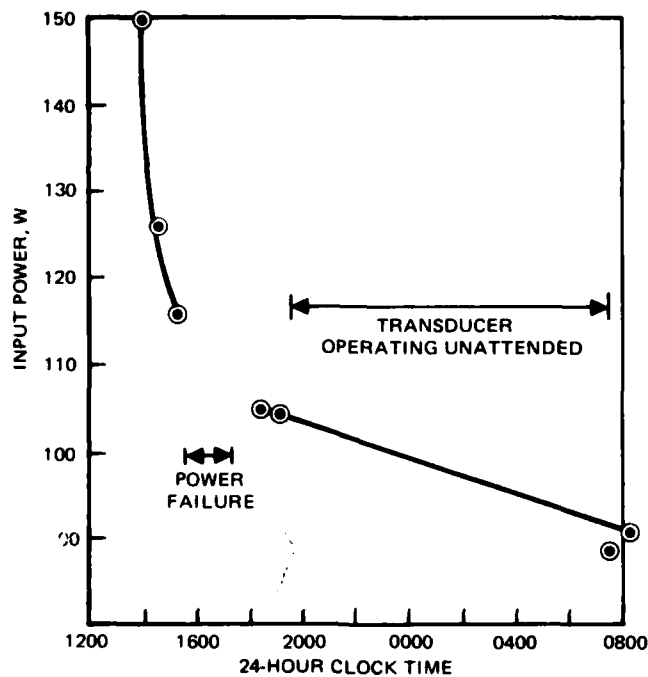

Figure A18. Input power vs time.

had been possible between 1715 and 1830 on 21 May. This conclusion is reinforced by the rapid drop in required input power when the *in-air* test was rerun at NOSC on 29 May. The lesser input power drop between 1930 on 21 May and 0815 on 22 May might have been due to further decrease in friction as the bearings were wearing in.

RECOMMENDATION

It is recommended that the windage loss characteristic of the projector be checked by a laboratory experiment and that the final conclusion be expressed in the form of a windage loss equation. This equation would relate windage loss power to the combination of the type of gas, ocean depth and temperature, and overpressure within the projector. The laboratory experiment would compare the windage losses at measured temperatures, first with helium, then with nitrogen. These data would then be compared with the Pend Oreille results.

APPENDIX B: NONRESONANT ACOUSTIC SOURCE OUTPUT POWER*

Naval Ocean Systems Center
San Diego, California 92152

2 June 1980

MEMORANDUM

From: HA Wilcox, Code 5304
To: TE Stixrud, Code 5313

Subj: Nonresonant Acoustic Source (NRAP) output power

1. The diameter of each of the two piston faces used in NRAP is 11.25 inches. Each piston is centered in a circular aperture of 12-inch diameter. A rolling rubber seal fills the annular gap between each piston and the housing, whence it follows that the rolling seal has an amplitude of motion which is half that of its associated piston. Hence the volume displacement amplitude for the combination piston plus seal is

$$\begin{aligned}\Delta V &= (\pi/4)D_p^2s + \left[(\pi/4)OD_s^2 - (\pi/4)ID_s^2 \right](s/2) \\ &= (\pi/4) \left[D_p^2 + (OD_s^2 - ID_s^2)/2 \right] s,\end{aligned}\quad (1)$$

where

D_p = piston dia

OD_s = OD of seal

ID_s = ID of seal

s = amplitude of piston motion (half the peak-to-peak throw of the piston).

Since

$$ID_s = D_p,\quad (2)$$

equation (1) can be written

$$\Delta V = (\pi/4) \left[(OD_s^2 + ID_s^2)/2 \right] s.\quad (3)$$

This ΔV is the same as for an "effective" piston diameter, D_{pe} , in the equation

$$\Delta V = (\pi/4)D_{pe}^2s.\quad (4)$$

*In this appendix the HAW-15 acoustic projector is referred to as the NRAP.

whence we see that

$$D_{pe}^2 = (OD_s^2 + ID_s^2)/2, \quad (5)$$

or

$$D_{pe} = \left[(OD_s^2 + ID_s^2)/2 \right]^{1/2}. \quad (6)$$

Putting in the applicable numbers for NRAP, we find its effective piston diameter to be

$$\begin{aligned} D_{pe} &= \left[(12^2 + 11.25^2)/2 \right]^{1/2} \\ &= 11.631 \text{ inches.} \end{aligned} \quad (7)$$

2. Hunter (ref B1) gives the power output formula for a small circular piston generating low frequency sound as

$$P = 2\pi^3 (\rho/c) f^4 (A \cdot s)^2, \quad (8)$$

where

P = average radiated acoustic power in ergs per second

ρ = water density in g/cm^3

c = velocity of sound in cm/s

f = frequency in Hz

A = piston area in cm^2

s = amplitude of piston motion in cm.

For two pistons operating in phase in the breathing mode in a projector whose dimension is small compared to the wavelength of the output sound, as in NRAP, the A · s products for the two pistons must be added before using the result in equation (8).

3. Inserting the numbers for the NRAP operating at Lake Pend Oreille into equation (8), we get

$$\begin{aligned} P &= 2\pi^3 \left[1/1.435(10)^5 \right] (15)^4 \left[(\pi/4) (11.631^2 \cdot 2.54^2) (0.391/2) (2.54) (2) \right]^2 \quad (9) \\ &= 1.0139(10)^7 \text{ ergs per second} \\ &= 1.0139 \text{ watts.} \end{aligned}$$

B1 Acoustics, by JI. Hunter, Prentice Hall, 1957, p 147.

Using the well-known fact that 1 watt re 1 μ Pa at 1 m is a sound level of 170.8690 dB, we can say that in our case

$$\begin{aligned} P &= 170.8750 \text{ dB re } 1 \mu\text{Pa at } 1 \text{ m} && (10) \\ &= \text{the NRAP source level.} \end{aligned}$$

4. The above calculations are probably accurate to about 2 percent, given the uncertainties in the input data.

**APPENDIX C: DISCLOSURE OF NEWLY INVENTED CAPABILITIES FOR
THE NONRESONANT ACOUSTIC PROJECTOR**

Naval Ocean Systems Center
San Diego, California 92152

2 June 1980

MEMORANDUM

From: H. A. Wilcox, Code 5304(B)
To: Ervin F. Johnston, Code 291(T)

Subj: Disclosure of Newly Invented Capabilities for the Non-Resonant Acoustic Projector (NRAP).

Ref. (a): Patent Disclosure of 14 September 1979 Titled "Non-Resonant Acoustic Projector with Adjustable Frequency, Adjustable Amplitude, Adjustable Depth, Drive Mechanism."

1. On 20 April 1980 (while I was on my recent vacation trip in the Middle East) I came up with a number of concepts for causing the NRAP (see ref. (a)) to perform in various novel and desirable ways.

2. To start with, fig. C1 shows how the amplitude of piston oscillation can be readily "switched," in a time very short compared with the pistons' basic period of oscillation, and in a manner which imposes essentially no impulsive loads on any of the machinery of the projector, from full-on to full-off and back again, or between a full-off and any desired intermediate value of piston oscillational amplitude, whenever the piston has reached a turning point (i.e., a zero-velocity point) in its cycle of operation. The turning point condition occurs twice per cycle, when the center of axle 30 passes approximately through the point 31 on fig. C1, and again when the center of axle 30 passes approximately through the point 40. Throughout this description, it is to be understood that axles 20 and 120 are fixed in location relative to the projector housing; also, link 100 is understood to have the same interaxle length as link 80. A solenoid-actuated clamp is located at point 93 so that it can clamp axle 90 to a fixed position relative to the housing at that location (it is to be understood that other means for clamping axle 90 in the position 93 might be devised). When axle 90 is thus clamped, then as rotor 10 turns about its axle 20 whose center 21 is fixed relative to the projector housing, the center of axle 60 is forced to follow the arcuate line of action 61 between the turning points 62 and 65. This arc of action 61 is centered on point 93, so axle 90 remains fixed and therefore cross arm 110 does not oscillate about axle 120 whose center is the point 121. Hence the piston linkages 150 and 160 do not move, wherefore the pistons 153 and 200 remain quiescent with a zero amplitude of oscillation. While the center of axle 60 is moving along the arc 61, axle 70 is constrained by a suitable slot or other means so that its center moves along some such line of action as 71 between the turning point 73 (when the center of 60 is at 65) and the turning point 72 (when the center of 60 is at 62).

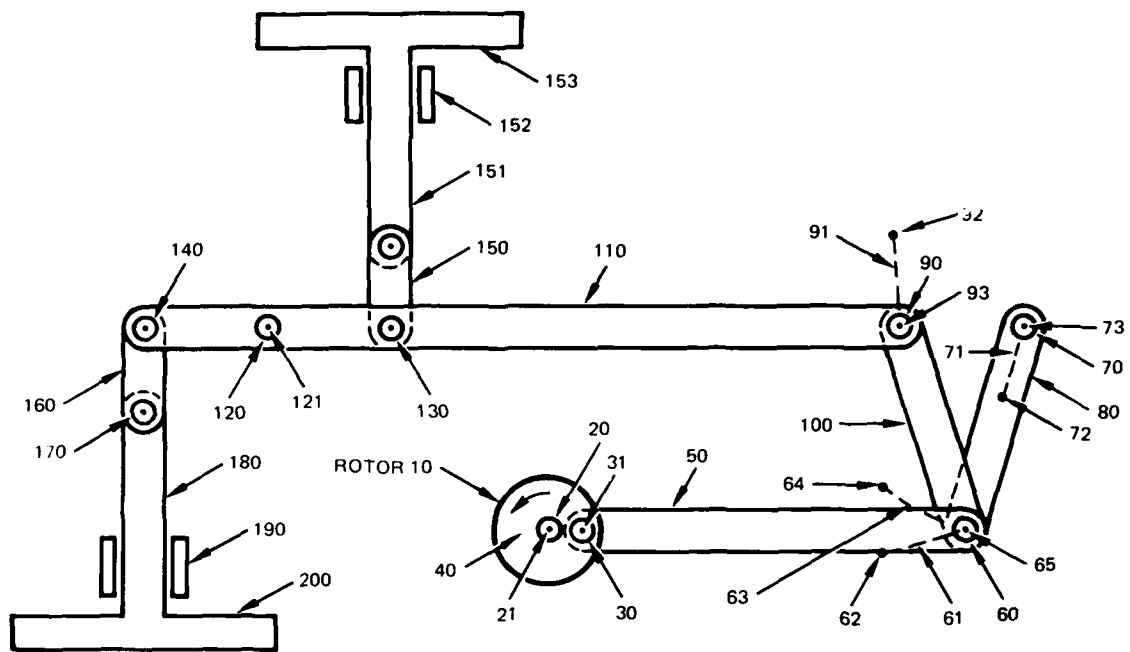

Figure C1.

If, now, when the center of axle 60 is at 65 and therefore the center of axle 70 is at 73, a suitably situated solenoid clamp or other means is used to suddenly clamp axle 70 relative to the projector housing while simultaneously the clamp on axle 90 is released, then as rotor 10 continues to turn the center of axle 60 is constrained to follow the new arcuate line of action 63 centered on the point 73. As axle 60 oscillates along 63 between the turning points 64 and 65, the center of axle 90 will be constrained to oscillate along the arcuate line of action 91 centered on point 121, wherefore the cross arm 110 must then oscillate about its axle 120 and so the piston linkages 150 and 160 must drive their respective pistons in the desired oscillating manner.

It is important to note, now, that the sudden switching change from a condition wherein axle 90 is clamped at location 93 to one wherein axle 70 is clamped at location 73, does not impose any significant impulsive loads on any of the machinery of the projector, because all linkages and pistons are then at or very near their zero-velocity points both before and also after the sudden switching action occurs; this is true despite the fact that the pistons are switched at that time from a condition of zero amplitude to a condition of full amplitude oscillation.

If and when it is desired to switch the projector back to a condition wherein the pistons are not oscillating, this can be accomplished, again without imposing any significantly large impulsive loads on any of the machinery of the projector, by suddenly clamping axle 90 while simultaneously releasing the clamp on axle 70 whenever the center of axle 60 reaches its turning point 65.

If it is desired to switch on the piston oscillation at a reduced amplitude of such oscillation, means are provided to bodily transport, without rotation, the axle 70 together with its guiding slot and clamping means, along a line from point 73 towards point 93. As 73 moves toward 93 it can readily be seen from fig. C1 that the amplitude of oscillation of axle 90 diminishes; in fact, if 73 is made coincident with 93, the amplitude of oscillation of axle 90 must vanish altogether, whence the piston motions must also vanish (i.e., the amplitude of their motion must vanish).

3. As a further invention, consider the system shown in fig. C2. Here the elements are all the same as in fig. C1 except that (1) the interaxle length of link 80 is made significantly shorter than the interaxle length of link 100, and (2) the above-mentioned means for bodily transporting axle 70 along with its clamp and its guiding slot (the "transport means") is designed to be able to move the center of axle 70 along the arcuate line 74 which is centered on point 65, for example. If, now, axle 90 is clamped with its center at point 93, the center of axle 60 must move along the line of action 61 and the center of axle 70 is forced to move along the line of action 71. However, if axle 70 is clamped with its center at point 73, then axle 60 is forced to move along the arcuate line of action

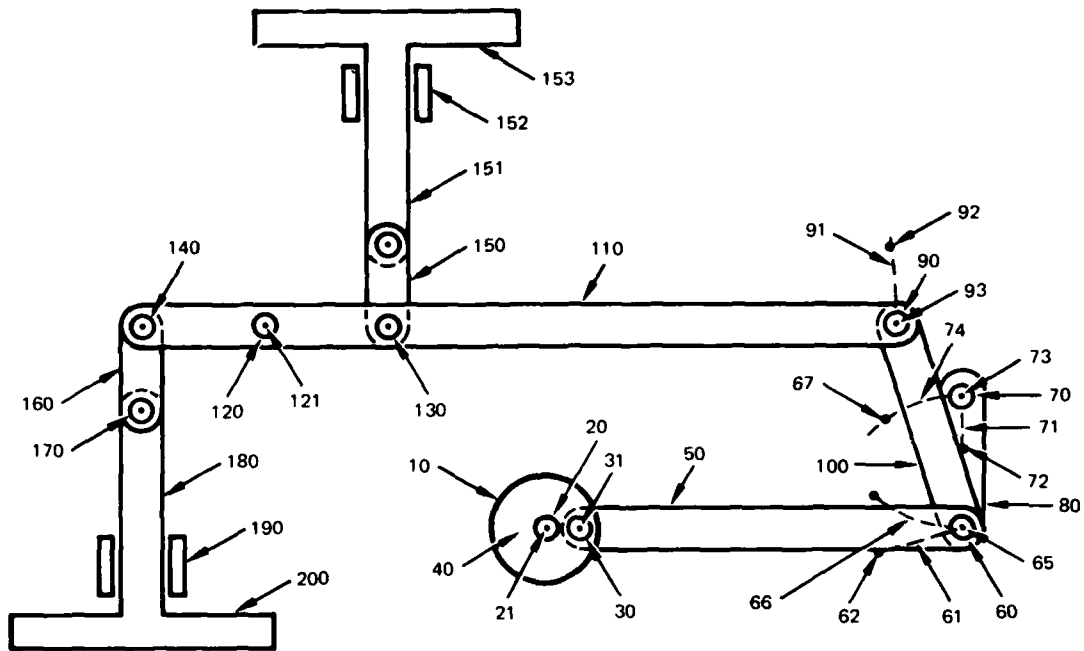

Figure C2.

66 centered at point 73 and axle 90 is forced to move along the arcuate line of action 91. Naturally, the here-described linkages do not produce a pure sinusoidal motion of the pistons, but instead that motion can be analyzed into its fundamental component at the rotor turning frequency plus its second, third, and higher harmonics at twice, three times, and higher integer multiples of the rotor turning frequency. If, now, axle 90 is unclamped and axle 70 is clamped, and if the transport means is then used to move the center of axle 70 away from 73 along the line 74, it can readily be seen that the amplitudes of the fundamental and of all odd-numbered harmonic components of the piston motion will fall as compared to the amplitudes of the second and all even-numbered components of that motion. Further, when the center of axle 70 reaches the point 67 which is equidistant from the turning points 65 and 62, the fundamental and all odd harmonics of the piston motion essentially vanish and only the second and even-numbered harmonic components of the motion remain. Hence this system is capable of varying the harmonic content of the piston motion in desirable ways, and it can in fact be used to suppress the fundamental and all odd-numbered harmonics of that motion essentially completely while continuing to put out very sizable amounts of the second and all higher even-numbered harmonics of the motion.

As described in section 2 above, this system can be used to switch suddenly between the various allowable modes of motion whenever the center of axle 60 is at its turning point 65.

Moreover, the systems of section 2 and of this section can be combined by using a link 80 in fig. C1 equal to link 100 in that figure along with a shorter link like that labelled 80 in fig. C2; this combination will then permit the abrupt switching of the pistons' output motion from that of the rotor frequency plus all higher harmonics to that of the second and all higher even-numbered harmonics of the rotor frequency.

4. As a yet further invention, consider the system shown in fig. C3. Here the system is the same as shown in fig. C1 except that (1) a clamp is introduced at the point 92, and (2) the linkage arm 300 is introduced along with a transport system for axle 310 and a clamp at the point 330. When axle 90 is clamped with its center at point 93, the center of axle 60 is forced to move along line 61, and the center of axle 70 must move along line 71, and the center of axle 310 must move along the line of action 320 (where 320 is determined by a suitable guidance slot, for example). If the axle 70 is clamped when its center is at point 73 while the axle 90 is then unclamped, the center of axle 60 will be forced to move along the line 63, and the center of axle 90 will be forced to move along the arc 91 between the two turning points 93 and 92, and the center of axle 310 will be forced to move along the line 320 between the two turning points 311 and 330. If, next, the axle 310 is clamped when its center

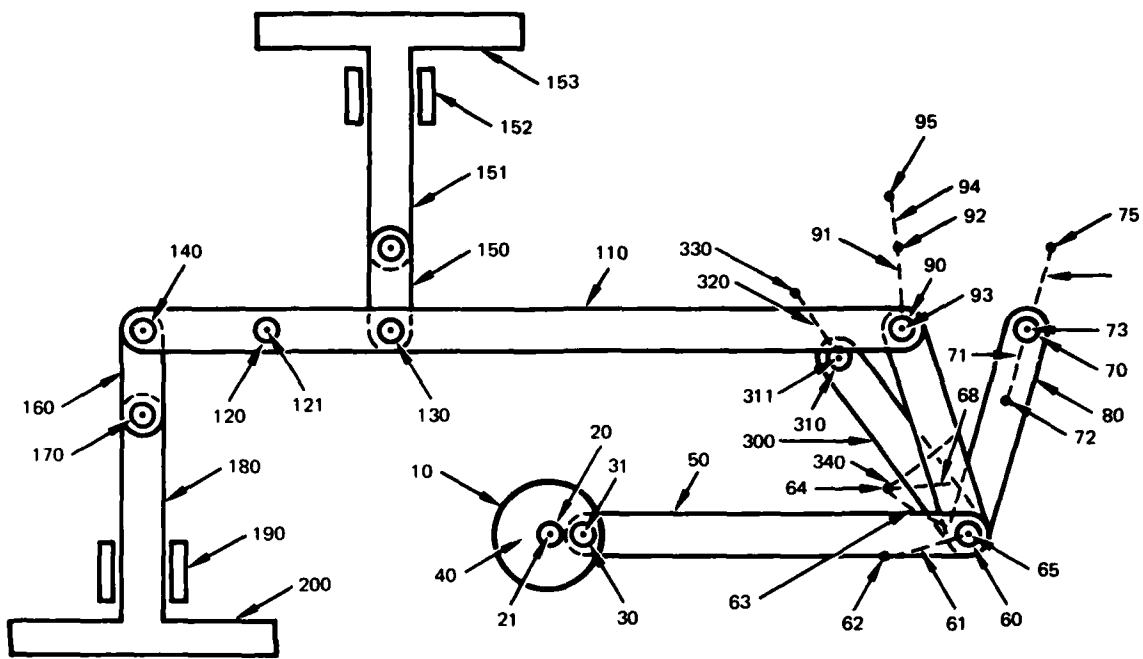

Figure C3.

is at the point 330, and if axle 70 is then simultaneously unclamped, the center of axle 60 will be forced to move along the arcuate line of action 340 centered on the point 330, the center of axle 70 will be forced to move along the line 74 (as determined by a suitable guidance slot or other means, for example), and the center of axle 90 will be forced to move along the arcuate line of action 94 between the two turning points 92 and 95, where the center of the arc 94 is the point 121. The desired result of the switching operation when axle 60 has its center at point 64 is that the piston velocity oscillation is then suddenly shifted by 180° in phase, again without producing any significant impulsive loads on any of the machinery of the projector. This last-mentioned switching operation can, of course, be reversed whenever the center of axle 60 is at the turning point 64.

Further, suppose that axle 90 has been clamped with its center at 93, and suppose that axle 90 is suddenly released while axle 70 is clamped when the center of axle 60 is at 65; then the center of axle 60 will be forced to move along line 63 to the turning point 64. If, now, axle 70 is released and axle 90 is clamped when its center is at the point 92 and the center of axle 60 is at the point 64, then the subsequent motion of axle 60's center will be along the arcuate line of action 68 centered at point 92, and the center of axle 70 will be forced to move along the line 74. The effect of these successive switching operations will then be readily seen to be to cause the pistons to engage in an odd number of half-oscillations. This result is often desirable, especially when the odd number of half-oscillations is chosen to be the number 1.

Clearly, by moving the transport mechanisms carrying axles 70 and 310 so as to bring those axles nearer to axle 90, the amplitudes of the above-described motions can be reduced individually to any desired degree, even to zero.

5. All the above-described systems can be combined to yield a single system capable of performing any of the described operations on command.

6. In summary, the NRAP projector of ref. (a) when modified according to this disclosure has the following capabilities:

(1) The rotor turning frequency, and hence all projector motions dependent on that frequency, can be quickly or slowly modulated (varied) independently of operating depth or amplitude(s) of the system.

(2) The amplitude(s) of operation of the system can be quickly or slowly modulated (varied) independently of the operating depth or frequency of the system.

(3) The depth of operation of the system can be varied without significantly changing the rotor frequency or amplitude(s) of the system.

(4) The amplitude(s) of operation of the system can be near-instantaneously switched full-off if on or full-on if off at suitably selected zero-velocity points in the motions of the linkage machinery of the system, and this switching can be accomplished without producing any significant impulsive loadings on any machinery of the system.*

(5) The phase of the piston velocity can be near-instantaneously switched by 180° at suitably selected zero-velocity points in the motions of the linkage machinery of the system, and this switching can be accomplished without producing any significant impulsive loadings on any machinery of the system.

(6) The basic frequency of the piston motion can be near-instantaneously switched between the rotor frequency and twice that frequency at suitably selected zero-velocity points in the motions of the linkage machinery of the system, and this switching can be accomplished without producing any significant impulsive loadings of any machinery of the system.

(7) By suitable design techniques the harmonic content of the system's piston motions can be tailored and/or varied to satisfy various postulated specifications.

*In particular, the amplitude of operation of the system can be switched full on for one or any odd number of half cycles, and then the amplitude can be switched full off again.

cc: Hightower
Pickens, Stixrud, Walton

INITIAL DISTRIBUTION

NAVAL ELECTRONIC SYSTEMS COMMAND
ELEX-320 (LCDR PAUL GIRARD)
ELEX-320 (DR. JOEL SINSKY)
PME 124-60 (E. CHAIKA)

NAVAL COASTAL SYSTEMS CENTER
CODE 724 (C. M. BENNETT)
CODE 721 (R. D. TURNAGE)

NAVAL RESEARCH LABORATORY
CODE 7558 (R. DINGER)

NAVAL RESEARCH LABORATORY
UNDERWATER SOUND REFERENCE DIVISION
SUPERINTENDENT (CODE 5900, J. E. BLUE)

NAVAL OCEAN RESEARCH AND DEVELOPMENT
ACTIVITY
CODE 110 (DR. RALPH GOODMAN,
TECHNICAL DIRECTOR)
CODE 500 (DR. R. R. GARDNER)

MARINE PHYSICAL LABORATORY, UNIVERSITY
OF CALIFORNIA
DR. VIC ANDERSON
F. FISHER

HYDROACOUSTICS, INC.
P.O. BOX 3818
ROCHESTER, NY 14610
J. BOUYOUCOS

UNIT X
DOCUMENTS EXPEDITING PROJECT
EXCHANGE & GIFT DIVISION
LIBRARY OF CONGRESS
WASHINGTON, DC 20450

DEFENSE TECHNICAL INFORMATION CENTER (12)

END

DATE
FILMED

1 8 1

DTIC