

MICROCOPY RESOLUTION TEST CHART

NATIONAL BUREAU OF STANDARDS-1963-A

REPORT DOCUMENTATION PAGE

READ INSTRUCTIONS BEFORE COMPLETING FORM

LEVEL II

12

AD A092662

1. REPORT NUMBER Technical Report #3		3. RECIPIENT'S CATALOG NUMBER	
4. TITLE (and Subtitle) A Modified Technique for Measurement of Orientation from Polymer Surfaces by Attenuated Total Reflection IR Dichroism.		5. TYPE OF REPORT & PERIOD COVERED technical report	
7. AUTHOR(s) C.S.P./ Sung		8. CONTRACT OR GRANT NUMBER(s) N00014-78-0676	
9. PERFORMING ORGANIZATION NAME AND ADDRESS Department of Materials Science and Engineering Massachusetts Institute of Technology Cambridge, MA 02139		10. PROGRAM ELEMENT, PROJECT, TASK AREA & WORK UNIT NUMBERS NR356-699(472)	
11. CONTROLLING OFFICE NAME AND ADDRESS Office of Naval Research 800 N. Quincy St., Arlington, VA 22217		12. REPORT DATE Nov 1980	
14. MONITORING AGENCY NAME & ADDRESS (if different from Controlling Office) TR-3		13. NUMBER OF PAGES 22	
		15. SECURITY CLASS. (of this report) unclassified	
		15a. DECLASSIFICATION/DOWNGRADING SCHEDULE	
16. DISTRIBUTION STATEMENT (of this Report) Approved for public release; distribution unlimited			
17. DISTRIBUTION STATEMENT (of the abstract entered in Block 20, if different from Report) S DTIC ELECTE DEC 08 1980 E			
18. SUPPLEMENTARY NOTES Prepared for publication in Macromolecules			
19. KEY WORDS (Continue on reverse side if necessary and identify by block number) Molecular Orientation Injection Molding IR internal reflection dichroism Double Edged Crystal Polypropylene Birefringence Surface orientation			
20. ABSTRACT (Continue on reverse side if necessary and identify by block number) For a sensitive measurement of surface molecular orientation by attenuated total reflection IR dichroism, a modified sample holder was developed utilizing a symmetrical, double-edged internal reflection crystal. This modified sample holder allows the sample to be rotated without the disassembling and reassembling operations which change the contact area between the polymer and the ATR crystal. Therefore (cont.)			

DDC FILE COPY

DD FORM 1 JAN 73 1473

80 12 01 298

↙
 correction of the reflectivities to an internal standard absorption band which is insensitive to orientation is not necessary in this modified apparatus. This was tested on two types of polypropylene. Results with uniaxially drawn polypropylene show that the surface orientation is similar to the bulk, as expected. On the other hand, the orientation as measured by this technique was greater on the surface than in the core of an injection molded polypropylene plate, a tendency confirmed by birefringence. This technique can be used for estimating bulk orientation of a thick sample without sectioning when the surface has similar orientation to the bulk. In cases where the surface differs significantly in orientation from the bulk, our technique should provide a more surface-sensitive estimation than birefringence, since the surface probed is much thinner (only about $1\ \mu$) in this technique.
 ↖

M. S. P. H.

Accession For	
NTIS GEM&I	<input checked="" type="checkbox"/>
DDC TAB	<input type="checkbox"/>
Unannounced	<input type="checkbox"/>
Justification	
By _____	
Distribution/ _____	
Availability Codes	
Dist	Mail and/or special
A	

Office of Naval Research
Contract N00014-78-0676
Task No. NR 356-699
Technical Report No. 3

A Modified Technique for Measurement of
Orientation from Polymer Surfaces by
Attenuated Total Reflection IR Dichroism

by

C.S.P. Sung
Department of Materials Science and Engineering
Massachusetts Institute of Technology
Cambridge, Massachusetts 02139

Prepared for publication in *Macromolecules*
November, 1980

Reproduction in whole or in part is permitted
for any purpose of the United States Govern-
ment. This document has been approved for public
release and sale; its distribution is unlimited.

Abstract

For a sensitive measurement of surface molecular orientation by attenuated total reflection IR dichroism, a modified sample holder was developed utilizing a symmetrical, double-edged internal reflection crystal. This modified sample holder allows the sample to be rotated without the disassembling and reassembling operations which change the contact area between the polymer and the ATR crystal. Therefore correction of the reflectivities to an internal standard absorption band which is insensitive to orientation is not necessary with this modified apparatus. This was tested on two types of polypropylene. Results with uniaxially drawn polypropylene show that the surface orientation is similar to the bulk, as expected. On the other hand, the orientation as measured by this technique was greater on the surface than in the core of an injection molded polypropylene plate, a tendency confirmed by birefringence. This technique can be used for estimating bulk orientation of a thick sample without sectioning when the surface has similar orientation to the bulk. In cases where the surface differs significantly in orientation from the bulk, our technique should provide a more surface-sensitive estimation than birefringence, since the surface probed is much thinner (only about 1μ) in this technique.

Introduction

The surface of polymers can be represented by different structures and compositions from the bulk, for example as a result of processing conditions or photo-degradation. Therefore, careful characterization of the polymer surface is essential to understand and improve surface-related properties.

Although many techniques are available for the determination of the structure of polymers in the bulk, IR spectroscopy appears to be one of the most amenable for surface characterization. We have directed our attention in this study to the measurement of surface molecular orientation in comparison to bulk values by employing IR spectroscopy. Measurement of bulk molecular orientation by transmission IR dichroism with thin polymer films is a well-established technique.⁽¹⁾ However, the use of attenuated total internal reflection spectroscopy (ATR) for measurement of orientation on polymer surfaces is experimentally more difficult, in spite of the well-developed theoretical basis for ATR of anisotropic polymers. According to Fluornoy and Schaffers,⁽²⁾ three optical constants, k_x , k_y and k_z of the polymer film, are related to the reflectivities for the transverse electric (TE) and the transverse magnetic (TM) waves, where the x-axis is the axis of drawing with the y and z axes parallel and normal to the film plane, respectively, as defined in Figure 1. With the film sample oriented with its x-axis normal to the plane of incidence, the following two equations for the reflectivities are obtained by rotating the polarizer by 90°:

$$\ln R_{TE \cdot x} = -\alpha k_x \quad (1)$$

$$\ln R_{TM \cdot x} = -\beta k_y - \gamma k_z \quad (2)$$

where α , β and γ are the functions of the refractive indices of the sample and the reflection crystal and the angle of incidence. A rotation of the film sample about the z-axis by 90° will place the y-axis normal to the plane of incidence, which will result in two additional equations:

$$\ln R_{TE \cdot y} = -\alpha k_y \quad (3)$$

$$\ln R_{TM \cdot y} = -\beta k_x - \gamma k_z \quad (4)$$

In theory, a measurement of any three of the four reflectivities will yield values for k_x , k_y and k_z . In practice, when the sample is rotated it involves disassembling and reassembling the sample from the crystal in the sample holder, frequently leading to a different contact area after rotation. Since the reflectivities are very strongly dependent on the area of contact, the errors could be substantial in these measurements. The usual procedure to minimize this type of error is to identify a particular absorption band which does not show dichroism upon drawing, and to normalize the reflectivities of all dichroic bands to the reflectivity of that band.^(3,4) Often it is difficult to identify such a band, especially in highly-drawn polymers. In order to solve this problem, we have designed a special ATR sample holder that can be rotated by 90° as a whole and thus does not require disassembling or reassembling during sample rotation. This was achieved by using a completely symmetric crystal in regard to the z axis, i.e., a double-edged square parallelogram⁽⁵⁾

crystal rather than the conventional single-edged rectangular-parallelogram crystal. The details of the new ATR set-up will be described. We will report some results obtained with this method, especially on the measurement of the dichroic ratio, k_x/k_y , on polypropylene surfaces in comparison to their bulk. It is noted from the above equations that the polarizer does not need to be rotated for the measurement of k_x/k_y , since only equations (1) and (3) are necessary.

Experimental

Sample Polymers

Two polypropylene samples were used. The first type was a film from Amoco (1050-14 grade) courtesy of the Army Materials Research Center, Watertown, MA. This film was uniaxially drawn either at 25°C or 150°C, in an Instron environmental chamber, up to the draw ratio of about 8. Only center portions of the drawn film were analyzed. The thickness of the film varied from 50 μ before drawing to about 20 μ at the highest draw ratio studied. The depth of the surface studied by ATR at 1168 cm^{-1} was about 1 μ , while the transmission IR data sampled the whole thickness.

The second type of sample was injection molded polypropylene received courtesy of Metal Box Ltd. of England. Since the injection molded polypropylene was too thick (8 mm) to run transmission spectra, the sample was microtomed and polished to expose the core surface, and the core dichroic ratio was taken from ATR spectra of that surface.

ATR Apparatus

The KRS-5 crystal used in this study has the configuration of a parallelogram with a square top and bottom plane (25 mm x 25 mm x 3 mm). The four edges of the crystal were formed at a 45° angle as shown in Figure 2(a). The crystal is therefore symmetrical if rotated by 90° around the z-axis. Three reflections occur when the IR beam enters the crystal at 53°. For comparison, the geometry of the conventional KRS-5 crystal is shown in Figure 2(b). It is a long, thin parallelogram with a rectangular top and bottom plane (50 mm x 20 mm x 2 mm) and only two edges at an angle of 45°, while the other two edges are perpendicular to the top and bottom planes. The number of reflections is usually greater than ten.

Figure 3 shows the arrangement in which the samples and the modified crystal are clamped together. A stainless steel C-clamp is fitted with two stainless steel blocks, or "pressure plates", one on each jaw of the clamp. The polymer sample and the KRS-5 crystal are placed between the pressure plates and the jaws of the clamp are tightened until the crystal and the sample are in intimate contact. Four holes have been drilled in one of the pressure plates, two holes in each of two adjacent edges. These holes mate with two stainless steel pins protruding from the side of the base plate of the ATR attachment, which is otherwise standard. The C-clamp, with the crystal and sample(s) in place, is then fitted to the base plate and the spectrum is recorded. From this spectrum and Equation (1), k_x can be calculated. By removing the entire ATR holder assembly with the samples clamped in place and refitting it to the base plate with the pins inserted in the second pair of holes in the pressure plate, measurement can be made at exactly 90° from the first one without disassembling the sample from the ATR sample holder. The C-clamp is designed so that it will not obstruct the optical pathways. From the second spectrum k_y can be calculated using Equation (3).

IR Analyses

ATR and transmission IR spectra were taken using a Digilab FTS-14 Fourier Transform IR spectrometer, with typically 100 scans at a resolution of 4 cm^{-1} . The twin parallel mirror-type ATR attachment (TMP-V00) and the modified crystals (KRS-5) were purchased from Harrick Scientific Corp. The

reflection attachment facilitated easy and efficient alignment, with the capability of variable incident angles from 25° to 75°, though an incident angle of 53° or 45° was chosen for this study. This angle is much greater than the critical angle, therefore reducing the distortion in the spectra. A germanium double diamond polarizer (PDD-01B) from Harrick Scientific Corp., which is a Brewster's angle crossed plate polarizer, was used as a polarizer of the IR beam because of its greater transmission intensity (over 50%) at over 90% polarizer efficiency. For the studies reported in this work, the polarizer was set at a trans-electric polarization only, since we were only interested in obtaining the dichroic ratio of k_x/k_y values. Even for obtaining the dichroic ratio of k_x/k_y for the bulk by transmission IR dichroism studies, the sample was rotated by 90° rather than the polarizer. Since the polarizer was not rotated either for surface or bulk studies, it was not necessary to correct for the instrument polarization effect, which is dependent on polarizer angle.

Birefringence Measurement

For birefringence measurement, specimens from the center of the injection molded polypropylene were cut both from the surface and the core, perpendicular to the z (thickness) direction. The thickness of the specimens measured using a Bausch and Lomb stereo microscope was about 60 μ . Birefringence was measured in a Reichert light microscope using a Berek compensator (a Leitz/Wetzlar calcite crystal).

Results and Discussion

In order to check the applicability of the modified rotatable sample holder to the measurement of dichroic ratios on the plane of polymer surfaces, uniaxially drawn polypropylene films were used. The drawing was carried out either at room temperature or at 150°C. Fluornoy⁽⁶⁾ had shown that when drawn uniaxially at 152°C, polypropylene films had similar surface orientation to the bulk. It is unlikely that drawing at 25°C will cause a difference, thus surface and bulk orientations in these samples would be expected to be similar. The surface dichroic ratio, k_x/k_y (where x is along the stretch direction and y is the transverse direction on the film plane), was measured by utilizing a rotatable sample holder and the bulk value was obtained by transmission technique by rotating the sample. Figure 4 shows the plot of the dichroic ratio, k_x/k_y , measured at 1168 cm^{-1} as a function of draw ratio in these drawn polypropylene films. With our apparatus we did not correct the reflectivities of the dichroic band at 1168 cm^{-1} to the reflectivity of an internal standard band which does not show dichroism upon drawing, but rather assumed the same contact area upon rotating the sample holder. The absorption band at 1168 cm^{-1} was chosen because its intensity was most convenient to use in this analysis. This band, which has been assigned to a complex mode of C-C chain stretching, CH_3 rocking and CH bending, is known to be sensitive to crystallinity (or helix length) since its intensity becomes quite weak in melt.^(8,9,10) It is a combination band even though much of its contribution comes from the crystalline phase.⁽¹¹⁾ This band is observed to exhibit parallel dichroism when uniaxially oriented,^(12,13,14) so it is expected that the dichroic ratio, k_x/k_y , defined as above would give values greater than one as a function of increasing uniaxial draw ratio. Indeed, Figure 4 shows that the dichroic

ratio k_x/k_y increases from about 1 to about 4 with the draw ratio. Furthermore, within experimental error, the surface has similar orientation to the bulk. Films drawn at elevated temperature (150°C) show slightly higher orientation than films drawn at room temperature, but still the bulk and the surface have similar orientation, which is consistent with Fluornoy's results. These results seem to support, within experimental error, our assumption of the same contact area upon rotation of the sample holder.

As an example of detecting different orientation between the surface and the core with our modified rotatable ATR apparatus, we have chosen an injection molded polypropylene plate. In many injection molded thermoplastics it has been observed that the surface is more oriented, usually in the flow direction of the molten polymer, due to the rapid cooling effect from the mold surface. For example, with injection molded polyethylene, Bakerdjian and Kamal⁽¹⁵⁾ observed the highest value of birefringence on the surface (~10 μ thick section), decreasing continuously toward the core of the molding. Tan and Kamal⁽¹⁶⁾ have confirmed this phenomenon of higher surface orientation along the flow direction by transmission IR dichroism studies on thin (~20 μ) microtomed sections of injection molded polyethylene. Therefore, it is reasonable to expect that similar trends would be observed in injection molded polypropylene. A small piece from the center of the injection molded polypropylene plate (3" x 3" x 1/4"), as shown in Figure 5, was examined by utilizing our rotatable ATR set-up. As summarized in Table 1, the surface dichroic ratio k_x/k_y (x is the flow direction) was found to be 2.0, as compared with the dichroic ratio of 1.2 from the core of the specimen. The core was exposed by microtoming and polishing off half of the thickness. This result clearly suggests that the surface has higher orientation along the flow

direction than the core in the injection molded polypropylene, a tendency similar to what has been observed in injection molded polyethylene. However, Trott⁽³⁾ has reported that the surface dichroic ratio, k_x/k_y at 1168 cm^{-1} , as measured from ATR spectra using a 1462 cm^{-1} band as an internal standard, was sometimes less than one in some injection molded polypropylenes, especially with very high molecular weight polypropylene. Therefore, it was felt necessary to confirm our measurement of orientation by another independent technique. For the sake of convenience, we chose birefringence, whose results are summarized in the second column of Table 1. On the surface (about $60\ \mu$ in thickness), the birefringence was clearly evident, having an estimated value of 4×10^{-3} . In uniaxially drawn (at 110°C) polypropylene films, this level of birefringence corresponds to about 20% elongation.⁽¹⁷⁾ Even though the injection molding process would not produce uniaxial drawing on the surface and the polymer is in the molten state rather than at 110°C , the measured surface birefringence is in the reasonable range. In contrast, no appreciable birefringent activity was observed in the core of the sample under the conditions of our birefringence set-up. Since undeformed polypropylene is known to have almost zero value of birefringence,⁽¹⁷⁾ the core is likely to be composed of relatively undeformed spherulites. Overall, birefringence results show the same tendency as our IR measurements, in that the surface shows greater orientation than the core. However, direct comparison between birefringence and IR measurements is difficult for at least two reasons: first, in our IR work the surface is probed only in the order of $1\ \mu$, while in the birefringence method the surface probed is much thicker. Since it is experimentally difficult to microtome $1\ \mu$ thick sections which exhibit enough birefringence for accurate measurement, we feel that our IR technique is the more surface sensitive technique for the assessment of surface orientation. Secondly, the dichroic ratio at 1168 cm^{-1} comes

mostly from crystalline contribution, while the birefringence value has contributions from both crystalline and amorphous phases of the material.

Conclusions

We have demonstrated in this work that a modified ATR sample holder employing a double-edged square-top parallelogram as the internal reflection crystal can be used to characterize surface molecular orientation via attenuated total reflection IR dichroism. This modified sample holder allows the sample to be rotated without the disassembling and re-assembling operations which change the contact area between the polymer and the ATR crystal. Therefore correction of the reflectivities to an internal standard peak which is insensitive to orientation would not be necessary in this modified set-up.

Two types of polypropylene were used to test the applicability of this modified apparatus. Results with uniaxially drawn polypropylene show that the orientation as expressed by the dichroic ratio k_x/k_y on the plane of the surface is similar to the bulk dichroic ratio, which is expected. The measurement of orientation by IR transmission spectroscopy requires very thin films for many polymers, often as thin as a few microns. With thicker samples which are most likely the case in many polymer applications, the use of ATR technique could provide a means of obtaining a dichroic ratio from the surface of the polymer, provided that the surface and the bulk are expected to have similar orientation. This can be checked by other techniques for orientation measurement such as birefringence. Our results as demonstrated in Figure 4 seem to indicate a potential of using our modified rotatable ATR apparatus from the surface of polymers for the measurement of bulk orienta-

tion when the orientation of the bulk and the surface is expected to be similar.

The orientation as measured by this technique on the surface of the injection molded polypropylene was greater than the core of the sample, a tendency confirmed by birefringence measurement. When the surface has quite a different extent of orientation from the bulk or the core of the sample, as in the case of injection-molded polymers, our technique can be used as a more surface-sensitive technique for assessing orientation than birefringence.

Our technique has a disadvantage due to the smaller number of reflections as compared with the conventional ATR technique, which results in lower intensities in ATR spectra. This can be circumvented either by choosing a high intensity band for dichroic ratio calculation, by reducing the thickness of the symmetrical crystal, or by enlarging the crystal's other dimensions to some extent, to increase the number of reflections.

In order to provide more extensive information on orientation, it seems that the determination of k_z , the optical constant along the thickness direction, will be useful in addition to k_x and k_y which were obtained in this study. It seems also desirable to use multiple IR absorption bands, each assigned to crystalline, amorphous or a different conformer, respectively, to fully exploit our ATR-IR dichroism set-up. We hope to continue our future work in this direction.

Acknowledgements

This work was in part supported by the Office of Naval Research. Our gratitude goes to Dr. T. Hirschfeld for many helpful discussions, Dr. N.J. Harrick for his assistance in modifying a new ATR apparatus, and to Dr. P. Calvert for many constructive criticisms concerning the manuscript. We also acknowledge the able assistance of M.K. Tse and J. Courtet for IR and birefringence measurements, respectively.

List of Figures

- Figure 1. Geometry and definition of spatial axis for ATR IR dichroism on polymer samples.
- Figure 2. Dimensions and Optical Schematic of ATR attachment:
(a) Modified crystal which is a double-edged square-top parallelogram,
(b) Conventional crystal which is a single-edged rectangular-top parallelogram.
- Figure 3. Schematic of modified, rotatable ATR sample holder with C-clamp.
- Figure 4. Dichroic ratio, k_x/k_y at 1168 cm^{-1} as a function of uniaxial draw ratio for polypropylene drawn either at 25°C or at 150°C .
- Figure 5. Definitions of spatial axes in injection molded polypropylene. (Small, cross-hatched area is where the sample was taken for analysis.)

List of Tables

- Table 1. Characterization of Injection Molded Polypropylene Plate, Surface versus Core.

Table 1

Characterization of Injection Molded
Polypropylene Plate, Surface versus Core

	Dichroic Ratio k_x/k_y	Birefringence
Surface	2.0	4×10^{-3}
Core	1.2	$<1 \times 10^{-4}$

References

1. For the most recent review, B. Jasse and J.L. Koenig, *J. Macromol. Chem.*, C17(1), 61 (1979).
2. P.A. Fluornoy and W.J. Schaffers, *Spect. Acta*, 22, 5 (1966).
3. G.F. Trott, *J. Appl. Polym. Sci.*, 14, 2421 (1970).
4. N.I. Stas'kov, V.I. Golovachev and S.S. Gusev, *Polymer Science, U.S.S.R.*, A19-10, 2628 (1977).
5. A double edged trapezoidal crystal can be used for a different ATR accessory, for example Wilks Model #9.
6. P.A. Fluornoy, *Spect. Acta*, 22, 15 (1966).
7. G. Zerbi and L. Piseri, *J. Chem. Phys.*, 49, 3840 (1968).
8. W. Heinen, *J. Polym. Sci.*, 38, 545 (1959).
9. R.G. Quynn, J.L. Riley and D.A. Young and H.D. Noether, *J. Appl. Polym. Sci.*, 2, 166 (1959).
10. J.J. Brader, *J. Appl. Polym. Sci.*, 3, 370 (1960).
11. C.R. Desper, "Characterization of Materials in Research, Ceramics and Polymers", Chap. 16, p. 459-499, Syracuse Univ. Press, N.Y. (1975).
12. K. Abe and K. Yanagisawa, *J. Polym. Sci.*, 36, 536 (1959).
13. G. Natta, *J. Polym. Sci.*, 16, 143 (1955).
14. P.G. Schmidt, *J. Polym. Sci.*, A-1, 2317 (1963).
15. Z. Bakerdjian and M.R. Kamal, *J. Appl. Polym. Sci.*, 17-2, 96 (1977).
16. V. Tan and M.R. Kamal, *J. Appl. Polym. Sci.*, 22, 2341 (1978).
17. R.J. Samuels, *J. Polym. Sci.*, A3, 1741 (1965).

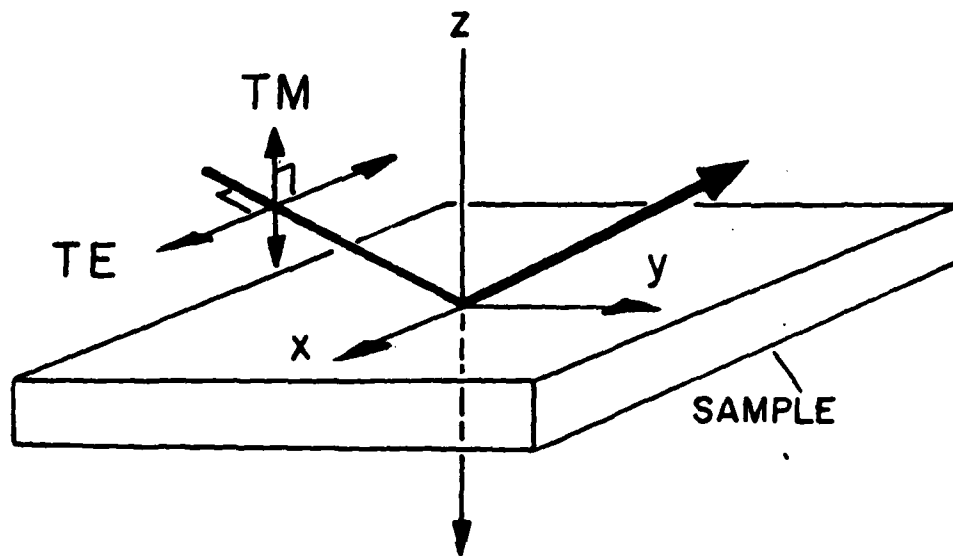

FIGURE 1

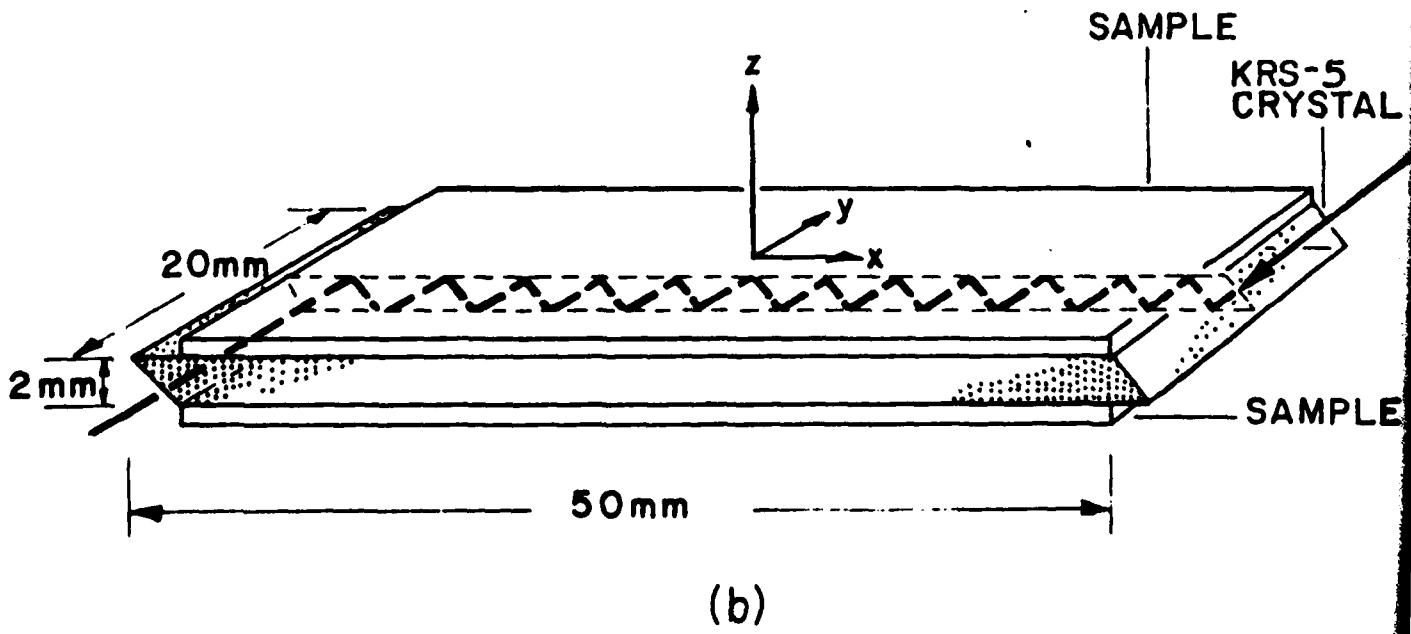
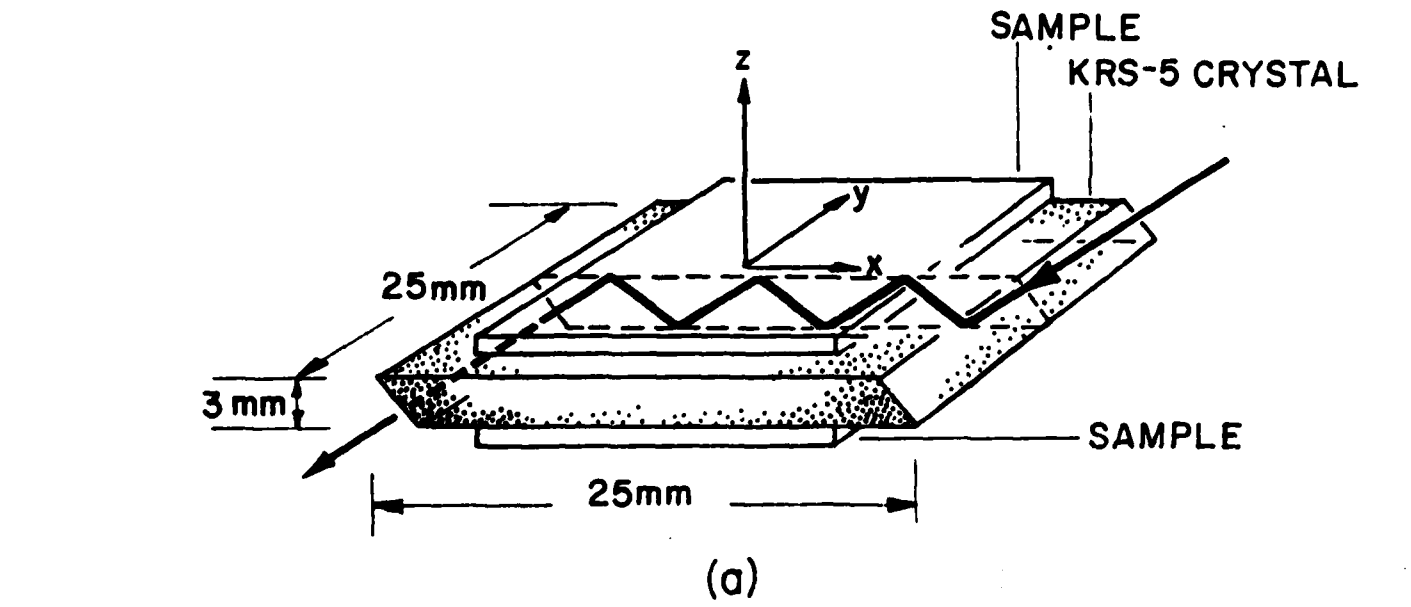

FIGURE 2

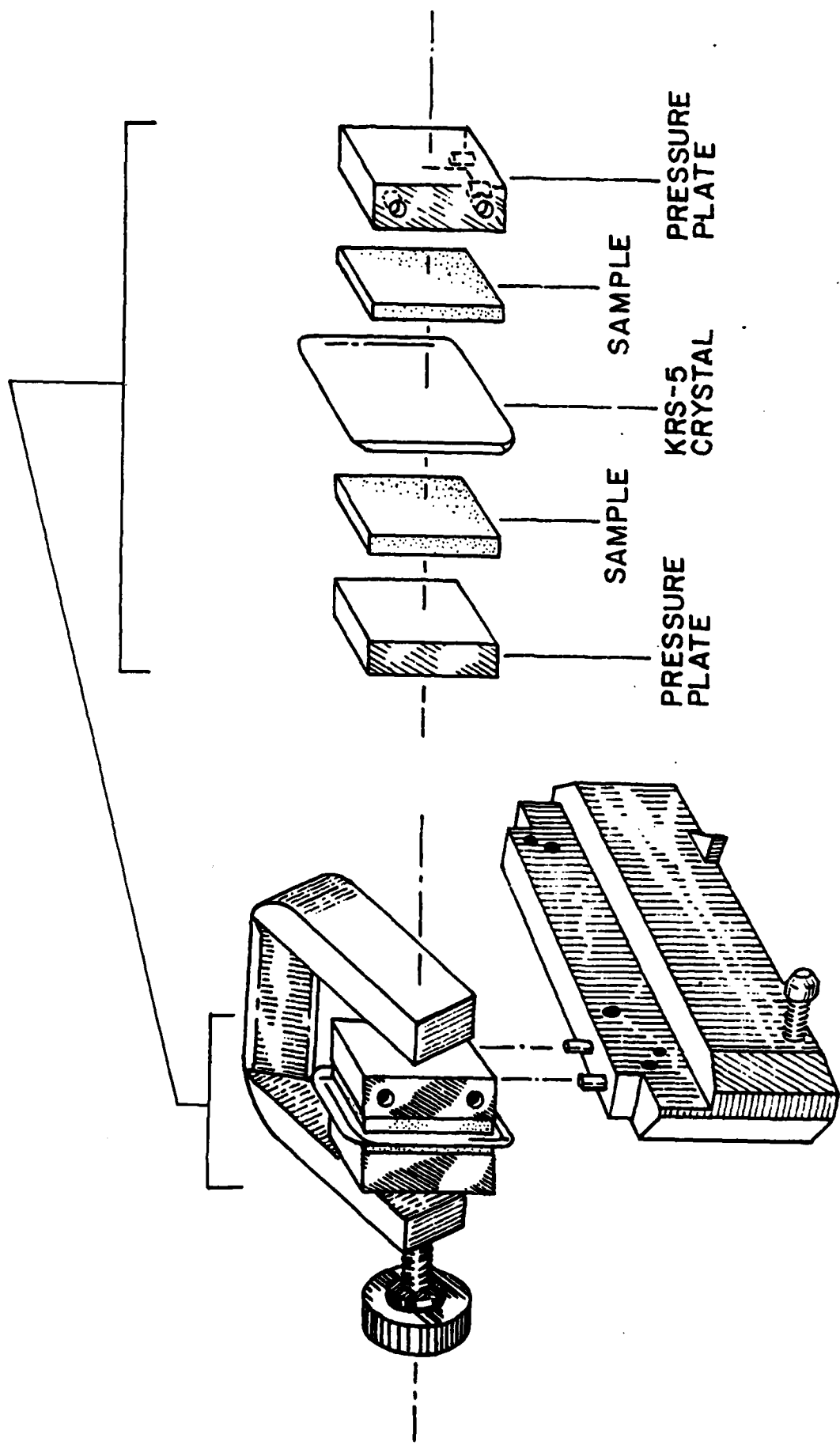

FIGURE 3

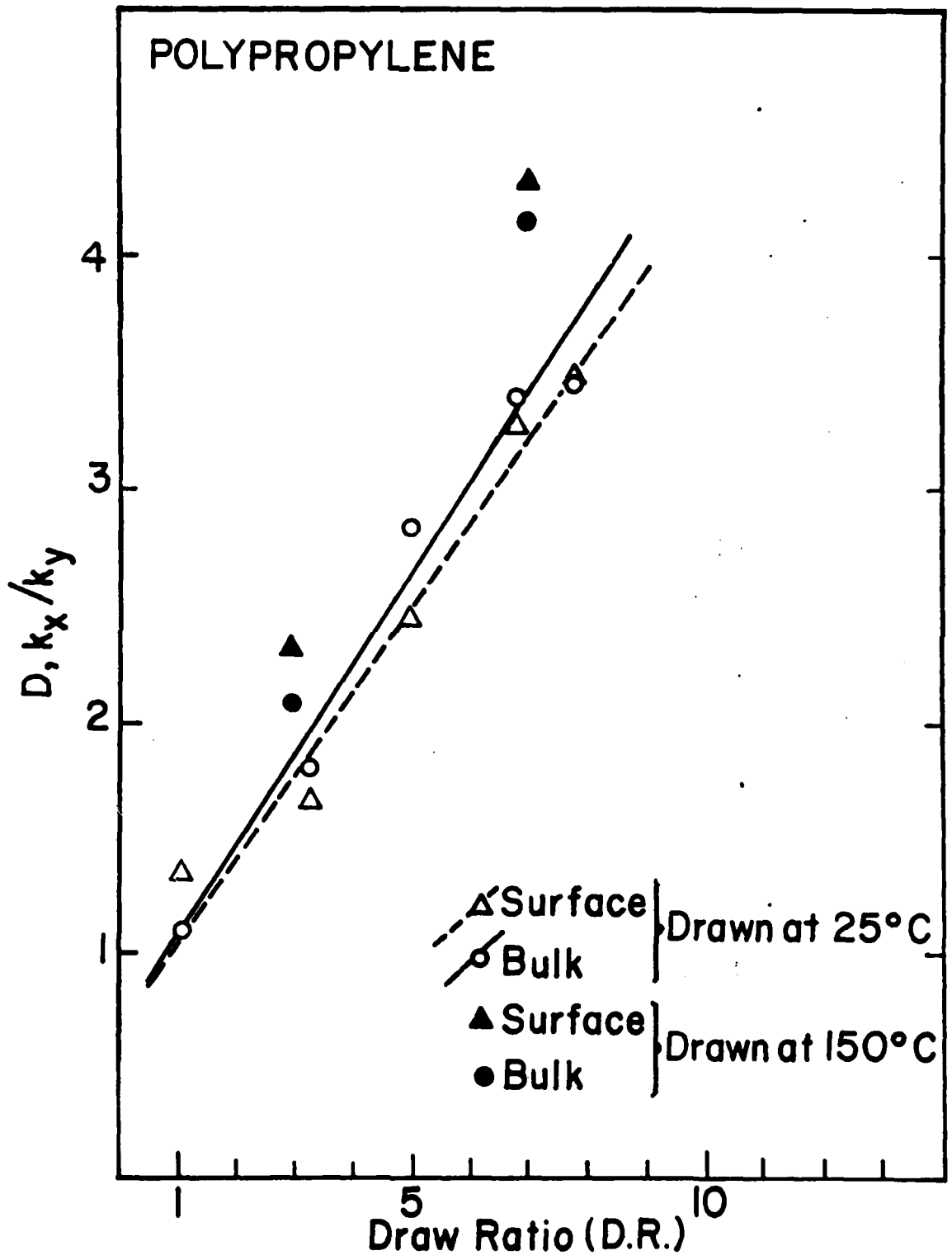

FIGURE 4

INJECTION MOLDED POLYPROPYLENE

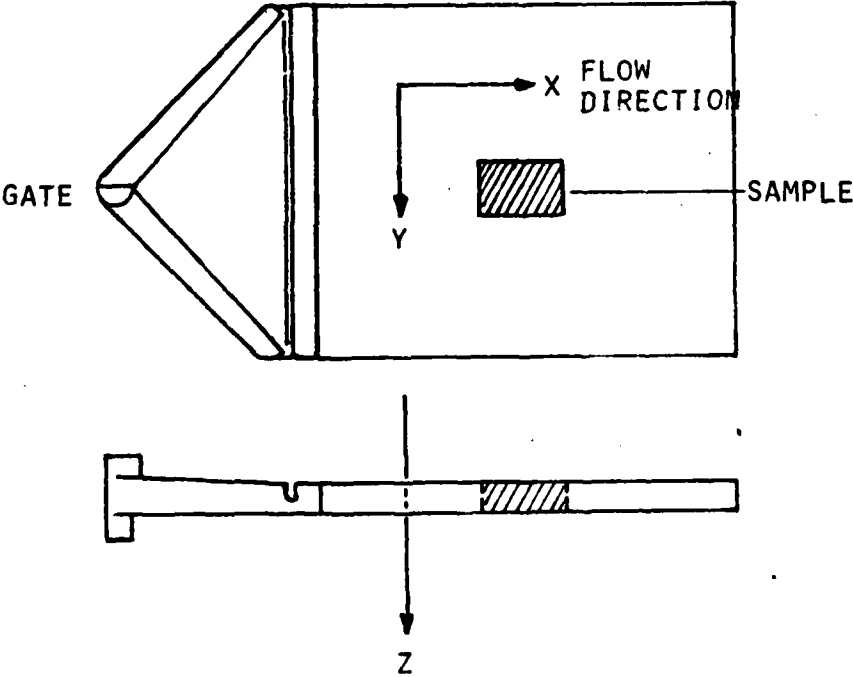

FIGURE 5

**DAT
ILMI**