

AD-A092 982

LTV AEROSPACE CORP DALLAS TEX Vought SYSTEMS DIV F/G 14/2
NON-DESTRUCTIVE INSPECTION TECHNIQUES FOR ACRYLIC CANOPIES, (U)
APR 76 G F THOMAS, S I SHELTON

UNCLASSIFIED

GIDEP-E114-2433

NL

1 - 1
AD-A092 982

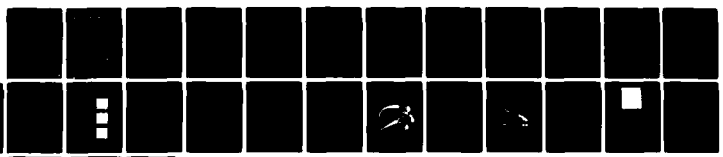

END
DATE
FILMED
18
DTIC

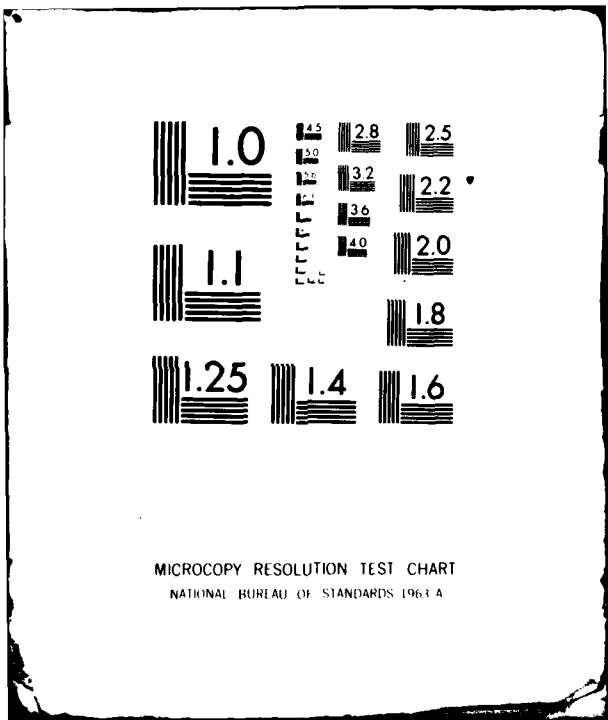

MICROCOPY RESOLUTION TEST CHART
NATIONAL BUREAU OF STANDARDS 1963 A

21 AUG 1978

GOVERNMENT-INDUSTRY DATA EXCHANGE PROGRAM

GENERAL DOCUMENT SUMMARY SHEET

1 OF 2

Please Type All Information - See Instructions on Reverse

1. ACCESS NUMBER E114-2433		2. COMPONENT/PART NAME PER GIDEP SUBJECT THESAURUS Nondestructive Testing, Analysis, Ultrasonic, Assembly	
3. APPLICATION ACFT		4. MFR NOTIFICATION <input type="checkbox"/> NOTIFIED <input checked="" type="checkbox"/> NOT APPLICABLE	5. DOCUMENT ISSUE (Month/Year) April 1976
6. ORIGINATOR'S DOCUMENT TITLE Non-Destructive Inspection Techniques for Acrylic Canopies		7. DOCUMENT TYPE <input checked="" type="checkbox"/> GEN RPT <input type="checkbox"/> NONSTD PART <input type="checkbox"/> SPEC	
8. ORIGINATOR'S DOCUMENT NUMBER AFML TR 70-54 21-32141		9. ORIGINATOR'S PART NAME/IDENTIFICATION N/A	
10. DOCUMENT (SUPERSEDES) (SUPPLEMENTS) ACCESS NO. None		11. ENVIRONMENTAL EXPOSURE CODES N/A	
12. MANUFACTURER N/A		13. MANUFACTURER PART NUMBER ----	14. INDUSTRY/GOVERNMENT STANDARD NUMBER

15. OUTLINE, TABLE OF CONTENTS, SUMMARY, OR EQUIVALENT DESCRIPTION

Describes three techniques: (1) a pulse-echo technique for detection of debond condition at the inner surface of the nylon and canopy glass, (2) a delta technique for detection of subcritical cracks in canopy glass, and (3) an angle beam technique for determination of the distance between the canopy glass and attach holes. A brief theoretical approach to each technique is presented in terms of wave propagation and response characteristics relative to location, size, type, and orientation of defects or variations in required material properties.

DTIC ELECTED
5 DEC 1980
A

Distribution limited to U.S. Gov t agencies only,
 Test and evaluation; **5 DEC 1980** other requests for
 this document must be referred to: OFFICER IN CHARGE
 DOCUMENT OPERATIONS CENTER, CORONA, CALIF.

16. KEY WORDS FOR INDEXING 79 04 24 111		18. PARTICIPANT ACTIVITY AND CODE Vought Corp, Dallas, TX 75222 (D4)	
17. GIDEP REPRESENTATIVE William E. Holleyhead		19. Unique; (Doc Des--P)	

INSTRUCTIONS FOR COMPLETING THE GIDEP GENERAL DOCUMENT SUMMARY SHEET

NOTE: Completion of a Summary Sheet by the participant is not mandatory for document acceptance into GIDEP. A Summary Sheet will be prepared by the GIDEP Operations Center for document submittals received.

PAGE 1 OF Enter the total number of summary sheet pages

BOX

- 1 Leave blank--entry will be completed by GIDEP Operations Center.
- 2 Enter standard nomenclature associated with GIDEP Subject Thesaurus selected from Section 12, Policies and Procedures Manual.
- 3 Indicate application which the device was used (e.g., ground, missile, shipboard, spacecraft; refer to P & P Manual, Section 13).
- 4 Device manufacturer must be notified of test results. Manufacturer approval of report is not required--include pertinent manufacturer correspondence with document submittal to GIDEP; check NOTIFIED entry. If document is for a nonstandard part or of a general nature and a manufacturer is not identified, check NOT APPLICABLE.
- 5 Enter month and year of document issue.
- 6 Enter complete document title exactly as it appears on originator document.
- 7 Identify document type by inserting letter X by appropriate descriptor.
- 8 Enter document number exactly as it appears on originator document.
- 9 Enter part name and identification as assigned by organization/agency originating the report; if not specified, enter N/A (Not Applicable).
- 10 Delete either SUPERSEDES or SUPPLEMENTS. If document supersedes/supplements an existing GIDEP document, enter GIDEP microfilm access number of appropriate document. If document neither supersedes nor supplements an existing GIDEP document, enter the word NONE.
- 11 Enter the single symbol coding for environmental exposure as defined in Subject Thesaurus, Section 12, P&P Manual (e.g., C - Salt Spray; V - Vibration; % - Shelf Life); if not specified, enter N/A (Not Applicable).
- 12 Enter manufacturer abbreviation and M-4 Code number listed in GIDEP Manufacturer List. If manufacturer is not listed, enter the phrase, SEE BOX 15; enter manufacturer's full name and division (if any) in Box 15. If more than one manufacturer, enter phrase, SEE BOX 15; enter additional manufacturers as appropriate. If manufacturer is not specified, enter N/A (Not Applicable).
- 13 Enter complete part number. Use open O for alpha letter O, and use 0 for numeric zero. If more than one part number, enter phrase, SEE BOX 15; enter additional part number(s). If a part number is not specified, enter four dashes (----).
- 14 Enter standard part number such as the 1N or 2N--diode and transistor designators. For GIDEP purposes, any military assigned number is considered as a government standard part number. If more than one standard number, enter phrase SEE BOX 15; enter additional standard number(s).
- 15 If subject matter in document can be categorized into more than one major subject category, enter additional subject categories in upper right-hand corner. Briefly summarize test results or material detailed in text of document. Include any pertinent details or comments required for proper interpretation of material presented (e.g., peculiar environmental capabilities, unique electrical characteristics that may be "state-of-the-art," or characteristics that restrict part usage to particular applications or any other details that may aid a prospective user of the part).
- 16 Enter appropriate words or phrases that enhance information retrieval on subject matter(s) contained in document. As a secondary data retrieval technique within each applicable Major Category (entry 2), the document is referenced in the computer data bank and Report Index according to each key word. Do not use abbreviations or words that are part of the subject category listed in Box 2. Key word phrases are limited to 60 total characters and blank spaces. Separate key words and/or phrases with commas.
- 17 Enter signature or name of GIDEP Representative.
- 18 Enter name, city, and state of participant activity or corporation and division submitting the document and GIDEP two-character code (e.g., X1).

INTRODUCTION

It is desirable to be able to insure that acrylic canopies are free of defects or variations in materials characteristics which could affect their structural adequacy. Non-destructive inspection (NDI) provides a means of monitoring several areas of concern, enabling detection of adverse characteristics before propagation beyond allowable limits occurs. The inspection techniques include a method of determining bond integrity for canopies with bonded edge attachments, a method of detection of subcritical cracks in stretched acrylic canopies and a method of monitoring the precise relationship of the glazing within the bonded edge attachment.

It is not suggested that these techniques are universally applicable to all designs without modification. These techniques are presented here to demonstrate a basic approach from which alternate techniques applicable to specific designs may be developed.

Ideally the NDI method selected should be applicable to both production inspection and in-service inspection of installed canopies.

NDI is a system based primarily on the use of various energy fields, each of which can be applied to the component to be inspected by various methods and techniques utilizing detailed test procedures. The traditional NDI approach is to:

- o Look for defects or variations in design tolerances.
- o Characterize these defects or variations in terms of required properties.
- o Select an inspection method/technique(s) sensitive to these conditions.
- o Set up (develop) and verify inspection procedures.

Ultrasonic was selected as the NDI method for the task described in this paper because of its reliability and also because of its versatility, adaptability, and applicability.

Visual inspection of installed acrylic canopies is limited in reliability. Small cracks which are readily visible on test specimens are considerably more difficult to detect visually on a canopy installed on an aircraft. This is due, in part, to the light-pipe effect where light enters the end of the test specimen and is reflected off the crack interface. Furthermore, the size of the specimen allows rapid reorientation to provide a favorable eye-to-specimen angle and specimen-to-illumination angle. On an installed canopy such a procedure is time consuming at best and may be physically impossible. Similar problems are encountered in visual inspection of bondlines of edge attachment member. Visual inspection cannot assess the relative location of the glazing within the edge member.

The ultrasonic techniques presented in this paper have no such limitations. A primary criterion in their development was that they be usable on

installed canopies. Suitable crew stands or other access to the canopy are all that is required for the inspection in addition to the ultrasonic apparatus.

The flaws utilized in proving these techniques were generated by artificial means, i.e. overstressing or overaging specimens constructed in canopy configuration. However, application to actual canopies is straightforward.

ULTRASONIC METHOD

Most ultrasonic testing employs pulsed energy in which a piezoelectric transducer converts high-frequency electrical signals or impulses into mechanical vibrations. The mechanical waves from the transducer are coupled to the material under test and serve as the probing sound energy medium. The coupling medium is usually oil or water.

Inspection is performed by an analysis of the ultrasonic waves received by the transmitter/receiver transducer, as in pulse-echo or shear wave techniques, or by a second transducer (receiver), as in the delta technique. Regardless of which ultrasonic technique is used, the received mechanical ultrasonic waves are converted back into electrical signals by the piezoelectric transducer and amplified and displayed on a cathode ray tube (CRT) for interpretation. The amount of energy received may be directly related to the defect orientation and cross-sectional area or to material variations, all with respect to the incident beam. Three main modes of vibration are commonly used in ultrasonic inspection: longitudinal, shear, and surface waves. For the types of conditions under evaluation in this paper, primary emphasis is directed to the longitudinal and shear modes of energy.

The more commonly employed techniques of testing with ultrasonic energy are best explained with emphasis on wave propagation. An oscillatory pulse of energy traveling in an unbounded elastic solid may have two distinct components, viz, longitudinal (compressional) and shear (transverse) waves. Longitudinal waves usually are generated at normal incidence in which the sound energy enters perpendicular to the material under test. Shear waves will be generated provided mode conversion occurs.

As a result of mode conversion within the material, longitudinal waves may become shear waves, and conversely. This conversion occurs when a sound beam strikes an interface between materials of different acoustic velocity or impedance properties, at other than normal incidence. In addition, sound energy may be converted to other modes of vibration during reflection or refraction. Within the material each mode of energy, longitudinal waves or shear waves, will propagate at their characteristic velocities for that material. Shear waves have a velocity of approximately one-half that of longitudinal waves. Longitudinal waves exist when the motion of particles of a medium is parallel to the direction of propagation. In shear waves, the particle motion of the material is perpendicular to the direction of wave propagation. The relationship of particle motion and wave propagation is depicted in Figure 1.

TECHNIQUES

General

Many important factors were considered in the development of the three techniques described herein. These factors dictated to a large extent the selection of a particular technique. A primary consideration was the capability of the techniques to be applied on installed as well as uninstalled canopies. Another major concern was the accessibility of the area of inspection relative to transducer placement or position. Finally, it was desired to provide technique applications and signal analysis which would be straightforward and readily interpretable by qualified personnel.

The three techniques were developed using a Sperry UM721 Reflectoscope, 10S db pulser/receiver, fast transigate, and off-the-shelf transducers. Preliminary laboratory evaluations were conducted in an immersion ultrasonic tank as shown in Figure 2 which provided controlled X, Y, and Z axes angular movement. A transducer manipulator device was also used in the development of the delta technique. Specially designed fixturing devices and inspection aids were developed and utilized. After tests had established the values of parameters for optimum operation, transducer wedges or holding devices with fixed dimensions and simpler design were made for routine inspection.

Transducer evaluation primarily consisted of experimentally selecting the transducer or combination of transducers which would provide sufficient ultrasonic energy within the inspection zone to detect the condition under evaluation. This was accomplished by optimizing transducer parameters such as frequencies, compositions, damping characteristics, shapes, and physical arrangements to provide maximum detection capability with minimum presentation of extraneous signals on the CRT screen.

Reference standards representative of the condition to be inspected were developed for each technique. The purpose of standards is to (1) establish inspection procedures, (2) determine sensitivity levels, and (3) standardize equipment. Repeatability of an inspection is of prime importance.

It was noted in development of all techniques that variations in temperature affect signal response. At canopy temperatures above approximately 90°F, increased attenuation may cause significant signal reduction. Therefore, it is required to reduce canopy temperatures to an allowable inspection level.

Pulse-Echo Technique for Detection of Debond Condition at the Inner Surface of the Nylon and Canopy Glass

In the case of determination of debond condition, the relationship between materials of different acoustic impedance is an important consideration. Generally, the greater the impedance mismatch between two adjacent materials, the greater the percentage of reflected sound energy. Conversely, the closer the impedance match between two adjacent materials, the greater the percentage of transmitted sound energy.

The expressions relating to sound energy interaction at normal (perpendicular) incidence to interfaces between two media is given as follows:

$$R = \left(\frac{Z_2 - Z_1}{Z_2 + Z_1} \right)^2$$

$$T = \frac{4Z_2 Z_1}{(Z_2 + Z_1)^2}$$

$$Z = PV$$

$$R + T = 1$$

where,

R = Coefficient of reflection

T = Coefficient of transmission

Z = Impedance (Z_1 and Z_2 = Acoustic impedance of respective media)

P = Density (material)

V = Velocity (sound)

Approximate acoustic impedance values for Nylon = 2.9, Acrylic = 3.1, and Air = .0004. It can be seen that a larger percentage of sound energy will be reflected from an acrylic/air boundary (debond) than from an acrylic/nylon boundary (bond).

The limited access to the area of inspection required construction of a special scanning device as depicted in Figure 3. The conical truncated collimator permits entry of the sound into the selected area without producing excessive spurious indications.

A 5.0 MHz, 0.187 inch diameter straight beam medium damped transducer connected by a coupling fixture to the collimator scanning device was used. Other size, type, and frequency transducers were evaluated but proved unacceptable for this application.

A reference standard was developed and is shown in Figure 4. The instrumentation was standardized by coupling the transducer holder to the standard with lightweight oil. Test sensitivity was adjusted to produce a response from the reference flaw of approximately 80% of the vertical scale on the CRT screen. This signal is electronically gated with an alarm level set to trigger at approximately 40% of the vertical scale. A typical CRT screen presentation of a bonded and non-bonded area is presented in Figure 5.

After standardization of equipment, the entire edge area was inspected as shown in Figure 6. The transducer holder is coupled by lightweight oil to the canopy. Scanning is accomplished by slowly sliding the transducer holder

along the canopy glass and observing the CRT screen and gate alarm level for any indication in the gate corresponding to the response from the reference flaw of the standard. When scanning, it is necessary to insure adequate couplant between transducer holder and canopy and that any response in the gated area on the CRT screen is caused by a debond condition and not from the canopy glass back surface in non-nylon backed areas.

All indications that equal or exceed the alarm level are marked for additional evaluation. By using the sensitivity settings noted above, debond conditions as small as 0.125 inch diameter have been detected and verified by additional testing.

Delta Technique for Detection of Subcritical Cracks in Canopy Glass

The detection of subcritical cracks posed a different problem than that presented by a debond condition. The position or orientation of a crack was such that standard pulse-echo or shear wave conceivably could not detect this condition as depicted in Figure 7. Also, accessibility to the area of inspection was of major concern. Therefore, a delta technique was used for detection of cracks.

The delta technique was named for the triangular positions or "delta" pattern of the search units (transducers) used in the ultrasonic test (see Figure 8). All forms of delta employ two or more transducers; one being a receiver that is positioned normal (perpendicular) to the surface being inspected, the other transducer is a transmitter that is angulated to introduce sound energy into the material at an angle that provides best energy partition. The axis of sound propagation of the receiver and transmitter transducers must lie in a common plane. The sound energy travels until it strikes an interface, is reradiated from the interface, and is detected by the receiving search unit (Figure 9). An interface is anything that has an acoustic impedance different from the parent material and results in an interruption of the propagation pattern of the sound beam.

As previously noted, when sound energy is propagated through one medium into another medium with different acoustical characteristics at an angle other than normal incidence, the sound energy is refracted. Two primary modes of energy are produced through refraction, longitudinal and shear waves. The angle of refraction depends on the ratio of velocities within the media and the angle of incidence of the transmitting search unit in relation to the boundaries of the media. The angle of refraction can be determined by Snell's Law as defined by

$$\frac{\sin \alpha}{V_c} = \frac{\sin \phi}{V_s} = \frac{\sin \beta}{V_L}$$

where,

- Sin = Sine of angle
- V_c = Velocity of sound energy in coupling medium
- V_s = Velocity of shear energy
- V_L = Velocity of longitudinal energy

The delta configuration used in this technique was first established using a laboratory fixturing device which permitted coupling through immersion of the test part and transducers and provided angulation and movement of transducer in the X, Y, and Z axes (Figure 10). The arrangement of transducers used in a delta head normally can be simple in that the distance between the transmitter and receiver transducers is a fixed distance and the angle of incidence of the transmitter is constant.

However, in order to obtain this relationship between the transducers and the material to be inspected a "trial and error" period must be experienced. A close approximation of the delta head design can be obtained through the application of simple mathematics and the use of the physical characteristics of the material under evaluation.

Optimizing the configuration consisted of determining the best combination of transducer composition, frequency, position, and angle of incidence. The optimum energy pattern produced is depicted in Figure 11. It can be seen that both longitudinal and shear wave energy is produced but the predominant energy pattern is longitudinal. Basically, the energy distribution was such that the area under inspection was flooded with energy uniformly distributed throughout the cross-section.

It was determined that using miniature 5.0 MHz, 0.250 inch diameter focused beam transducers composed of lead zirconate would produce optimum results. The configuration was used to design a plastic transducer holder (Figure 12) in which the coupling medium is lightweight oil.

A reference standard was developed and is shown in Figure 13. Artificial defects 0.125 x 0.062 inch (half circle) at an angle of 25° to 55° from the horizontal have readily been detected in test standards. The instrumentation was standardized on the reference standard as depicted in Figure 14. The response from the reference flaw is maximized and electronically gated. The signal height is adjusted to approximately 80% on the CRT screen. The alarm level was set to trigger the gate at a signal height of approximately 50% of the vertical scale.

After standardization of equipment inspection is performed as depicted in Figure 15. Scanning consists of slightly twisting the transducer holder while moving back and forth and to the right and left in relation to the area of interest and indexing approximately 0.050 inch increments along the canopy edge. During scanning, it is necessary to insure adequate couplant between the transducer holder and canopy, and within the transducer holder. Care must also be taken to assure removal of air bubbles within the holder.

All indications that equal or exceed the alarm level are marked for additional evaluation. Subcritical fatigue cracks in the order of 0.100 x 0.060 inch and approximately 30° - 40° from the horizontal have been detected in test parts. Detection of flaws smaller than 0.100 x 0.060 inch would increase the signal-to-noise ratio and increase spurious indications making interpretation of the response difficult.

Angle Beam Technique for Determination of the Distance Between the Canopy Glass and Attach Holes

The location of the edge of the canopy glass presented a problem unlike either of the foregoing techniques. An accurate determination is necessary to measure the distance between the edge of the canopy glass and the attach holes which are drilled into the nylon bonded to the glass. In the unassembled condition, although the nylon is translucent, an accurate visual measurement cannot be obtained. Also, after canopy installation with sealant and fasteners, no visual measurement is possible. Only the centerline of the fastener through the attach holes can be determined. The relation of the edge of the glass to these holes must be made ultrasonically.

Inspection of the area of interest required angulating the transmitter/receiver transducer. In this case longitudinal wave energy is primarily produced and propagates through the point of entry to the edge of the glass. The acoustic impedance mismatch between the nylon and glass causes significant reflection of the transmitted energy. Some energy is transferred into the nylon, but the major portion of energy is reflected back in the direction of the transducer.

The configuration of the edge of the glass causes the return path of the energy to assume divergent paths because of the dimensional variations and energy mode conversion. This presented a prime consideration in regard to required angulation of the transducer. It was necessary to select an angle which would provide a return path in which a significant portion of the energy would be detected by the transmitter/receiver transducer.

Establishing the technique was first conducted in an immersion research tank using water as the coupling medium. After test parameters were determined, a plastic transducer holder was fabricated (Figure 16) in which the transmitter is coupled to the holder. Experiments determined that 70° provided the optimum angle of incidence.

A 2.25 MHz, 0.500 inch diameter straight beam lightly damped lead zirconate transducer connected by a coupling device to the holder was used. Several other size, type, and frequency transducers were evaluated but were unsuccessful.

A reference standard was developed and is as described in Figure 17. The instrumentation was standardized on this standard as depicted in Figure 18. The response from the end of the standard is maximized at approximately 80% height and positioned at approximately 50% of the horizontal scale on the CRT screen. Using either the instrument markers or a grease pencil, the position of the leading edge of the response from the end of the standard was marked on the CRT. The pointer was positioned such that it is exactly in line with the end of the standard.

After standardization of equipment, inspection is performed as shown in Figure 19. The inspection procedure consists of scanning in the direction toward the end of the part and observing the CRT screen for the indication corresponding to the edge of the canopy glass. The transducer holder is positioned along the scan direction such that the leading edge of the response

appears at 50% of horizontal scale on the CRT as previously established. Holding the transducer holder in position, a mark is placed on the aluminum strip (or nylon) in line with the pointer. By establishing several marks and connecting them with a pencil, the edge of the acrylic glass is determined. Visual assessment can be made between the distance of the centerline of the fastener and the edge of the hole. Very close (± 0.005 inch) approximation between the edge of the canopy and the attach holes has been determined by this technique.

CONCLUSIONS

The ultrasonic equipment specified herein or equivalent equipment provides improved reliability of inspection of acrylic canopies. The inspection system is portable and lends itself to on-line field inspection. Suitable crew stands or other access to the canopy are all that is required for the inspection in addition to the ultrasonic apparatus.

The techniques are performed on the exterior surface of the canopy. No removal of the canopy from aircraft is required since each inspection can be done either in the installed or uninstalled condition.

The inspection task can be performed by trained, qualified, and certified service inspection personnel utilizing detailed procedures. The procedures developed and prepared for each technique define equipment, material, reference standard, and inspection requirements. Special transducer holders (wedges) and reference standards must be fabricated.

The time required to accomplish the inspection is approximately one hour for the debond technique and two hours each for the other two techniques.

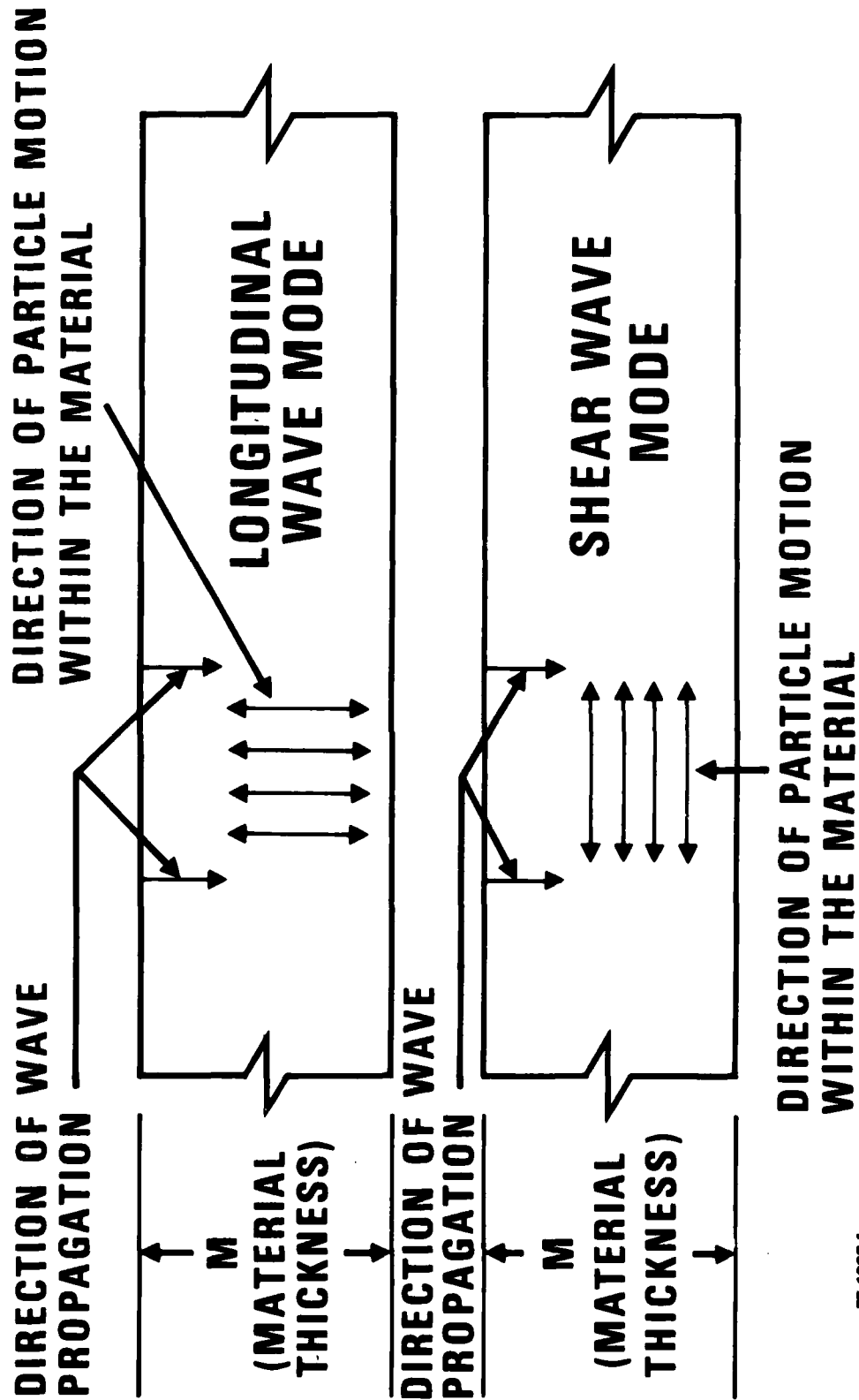

Figure 1. RELATIONSHIP OF PARTICLE MOTION AND WAVE PROPAGATION

FB-1023-1

//

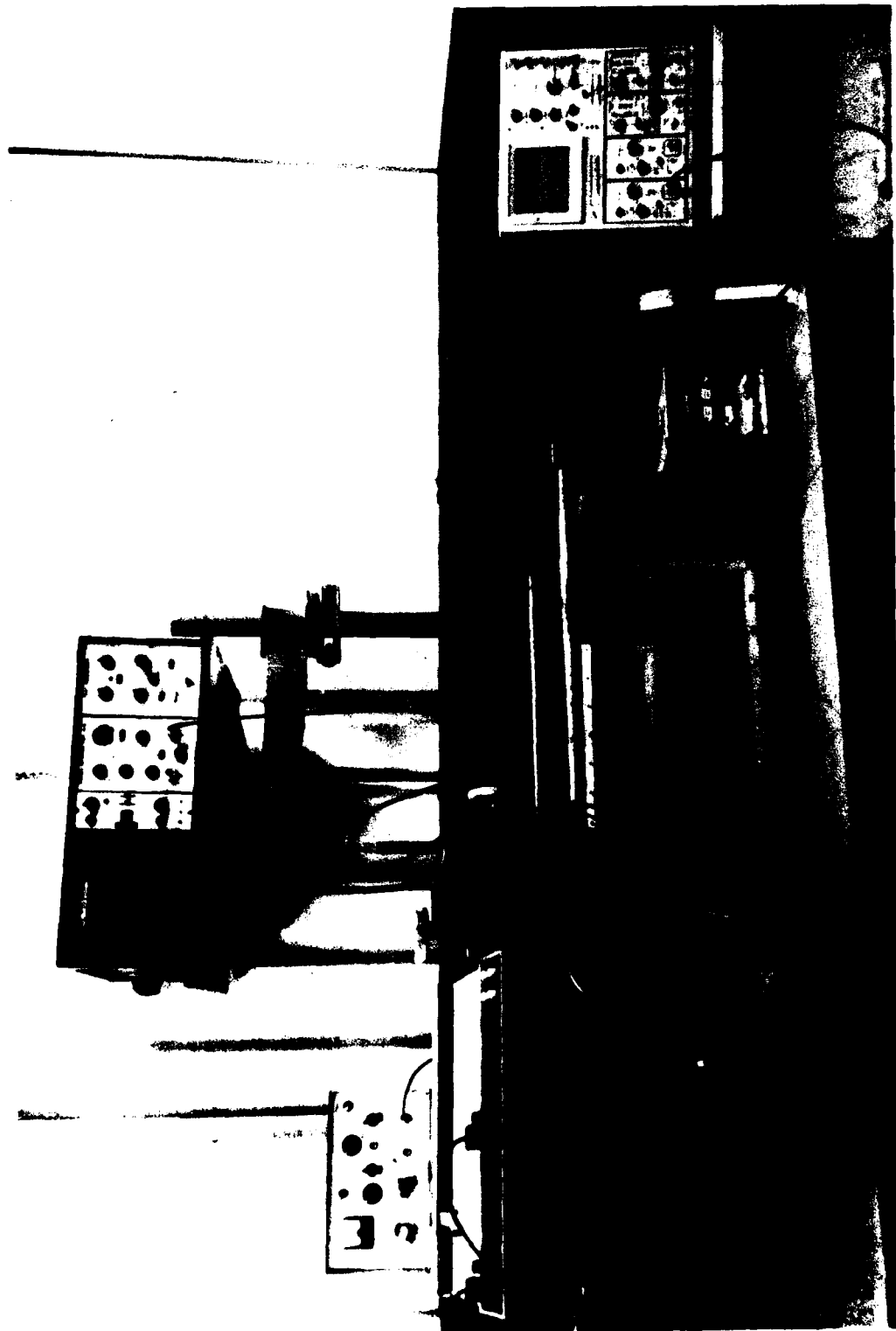
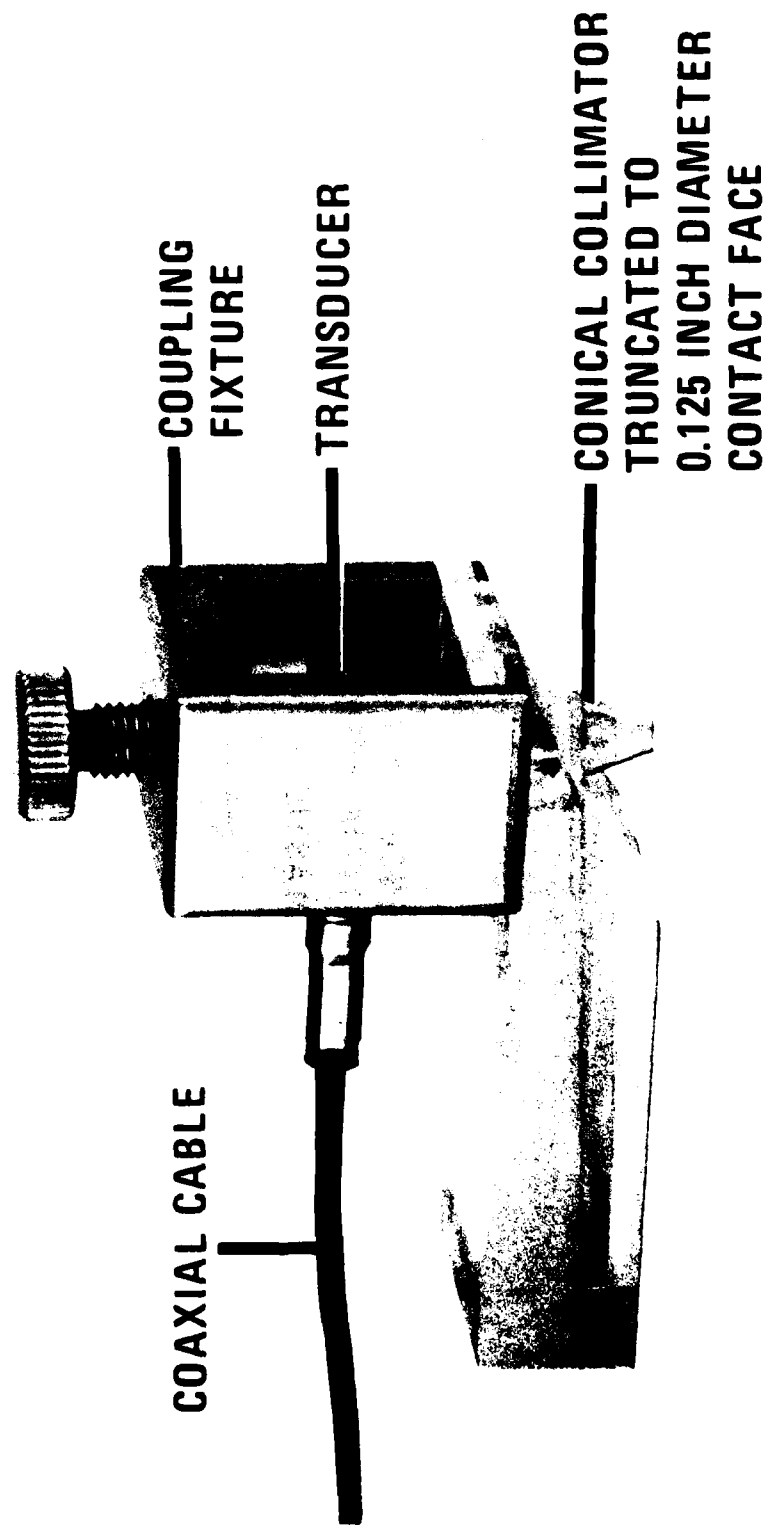

Figure 2. LABORATORY - ULTRASONIC TEST SYSTEM



317

Figure 3. TRANSDUCER HOLDER - PULSE ECHO TECHNIQUE

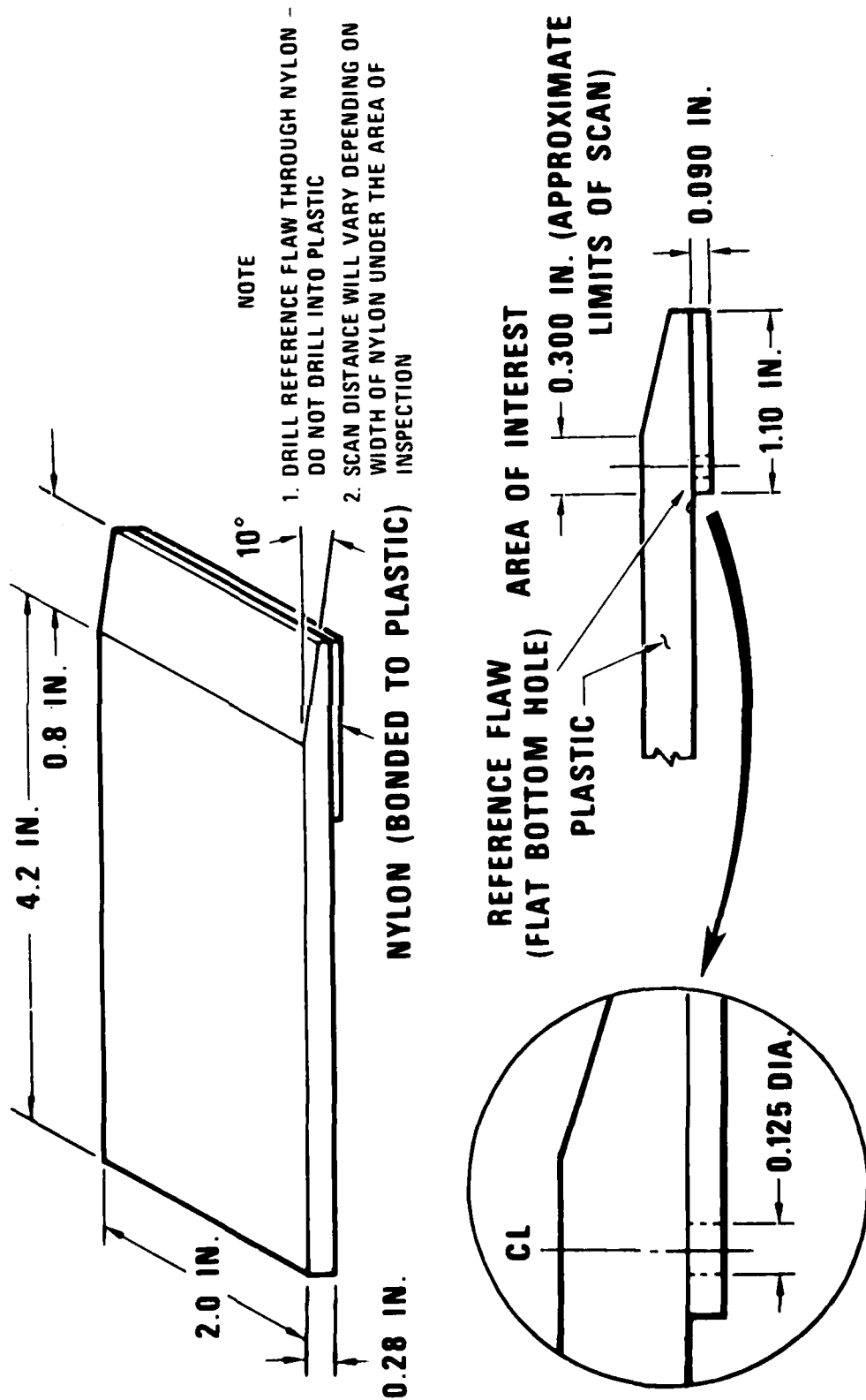

Figure 4. REFERENCE STANDARD - PULSE ECHO TECHNIQUE

15

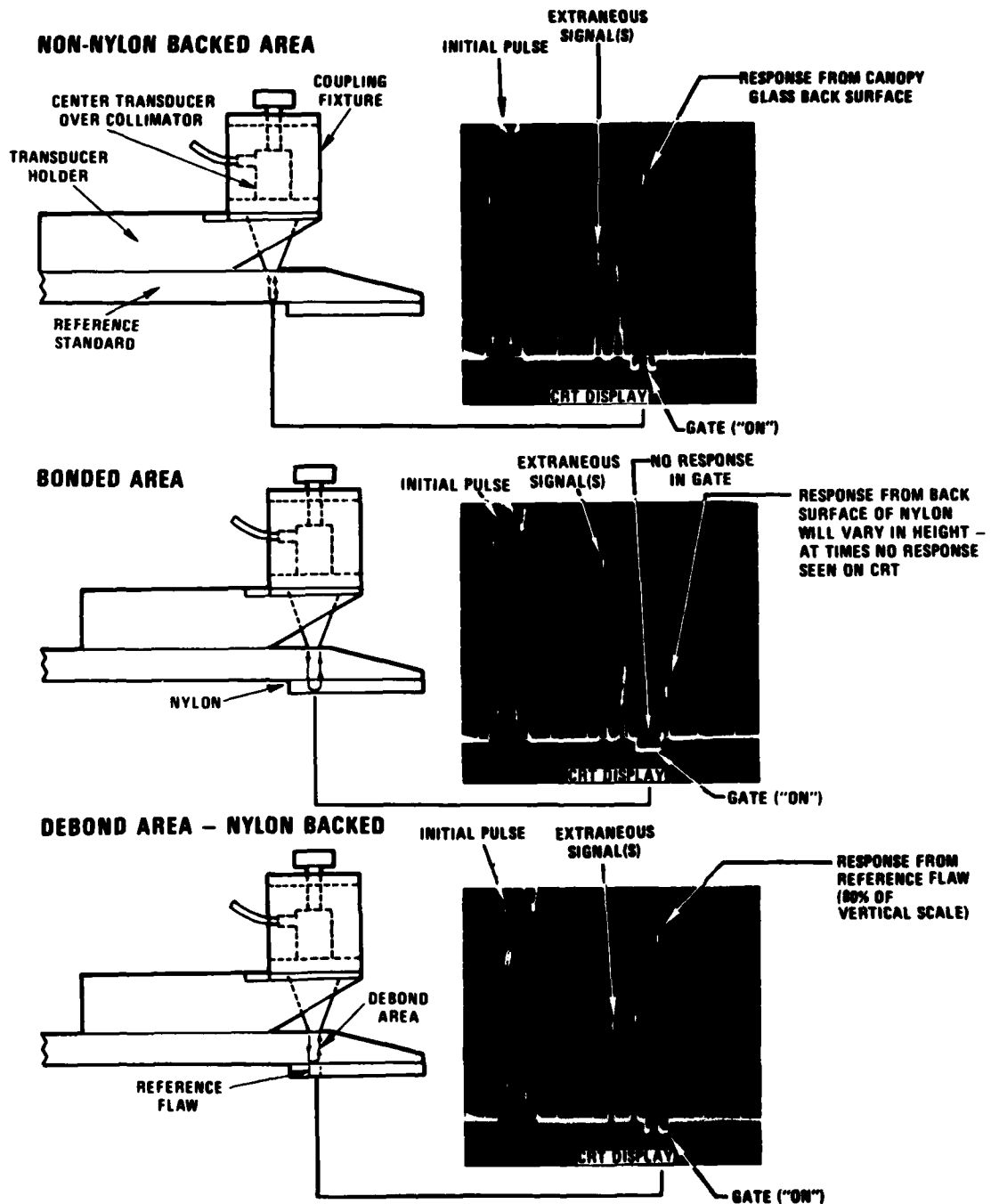

Figure 5. TYPICAL CRT SCREEN PRESENTATION - PULSE ECHO TECHNIQUE

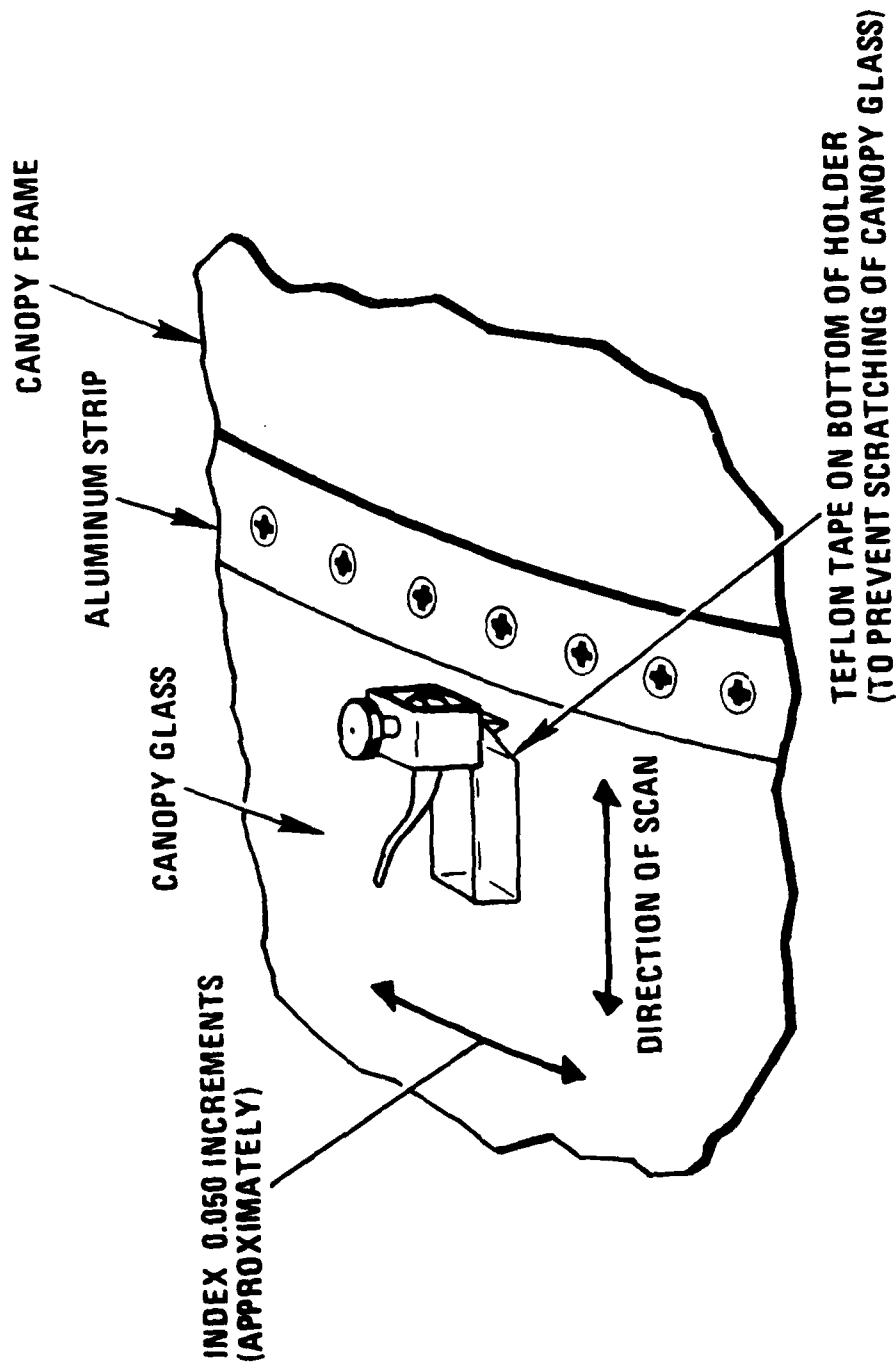
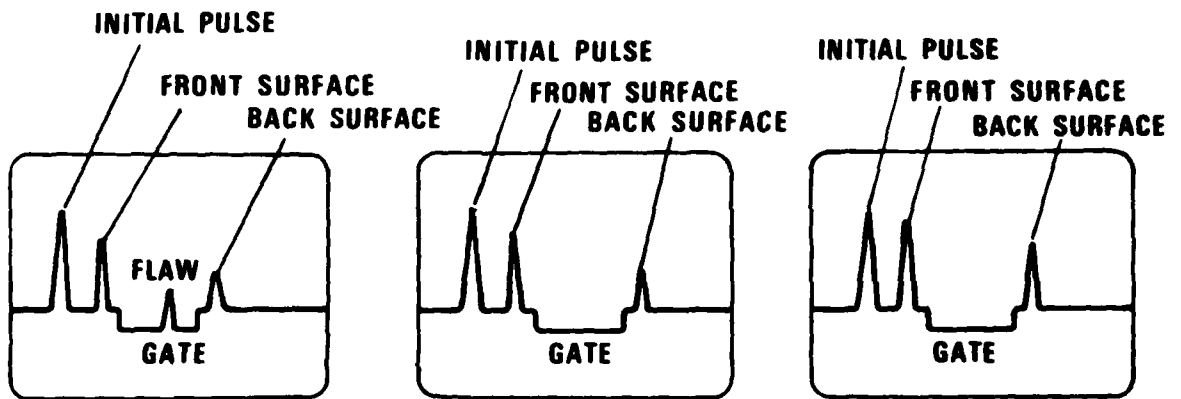
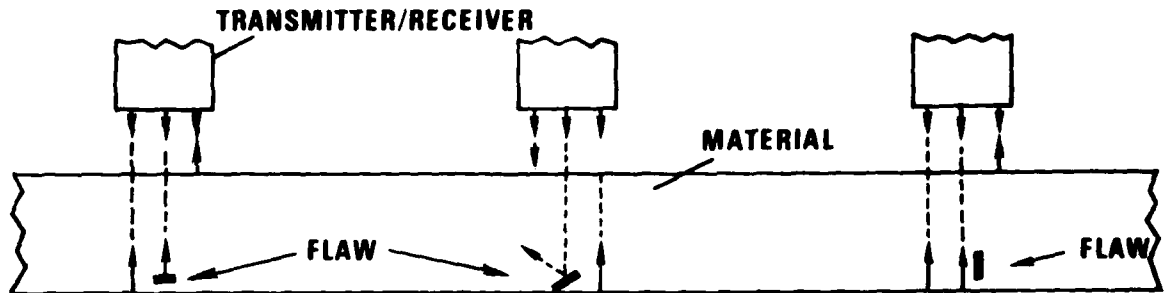

Figure 6. TYPICAL PLACEMENT OF TRANSDUCER HOLDER ON AREA OF INSPECTION - PULSE ECHO TECHNIQUE

PULSE ECHO TECHNIQUE



SHEAR WAVE TECHNIQUE

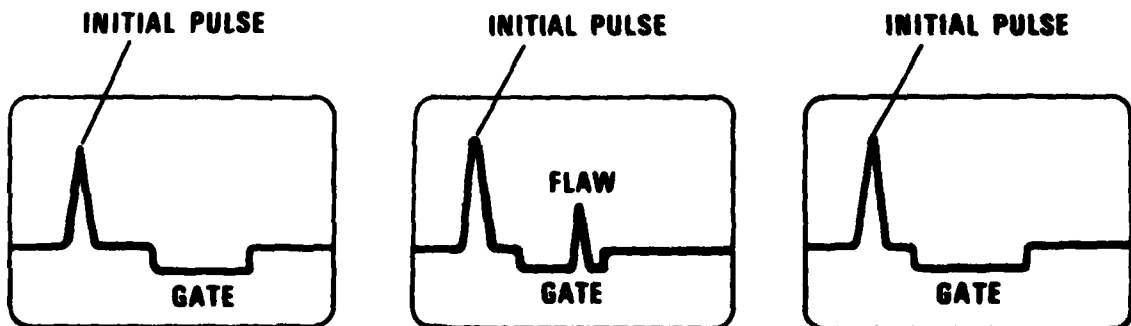
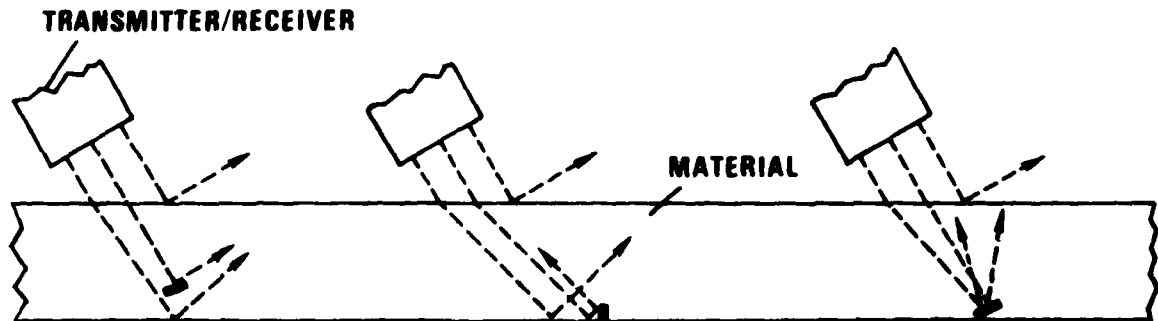

Figure 7. CRACK ORIENTATION RELATIVE TO DETECTION CAPABILITY

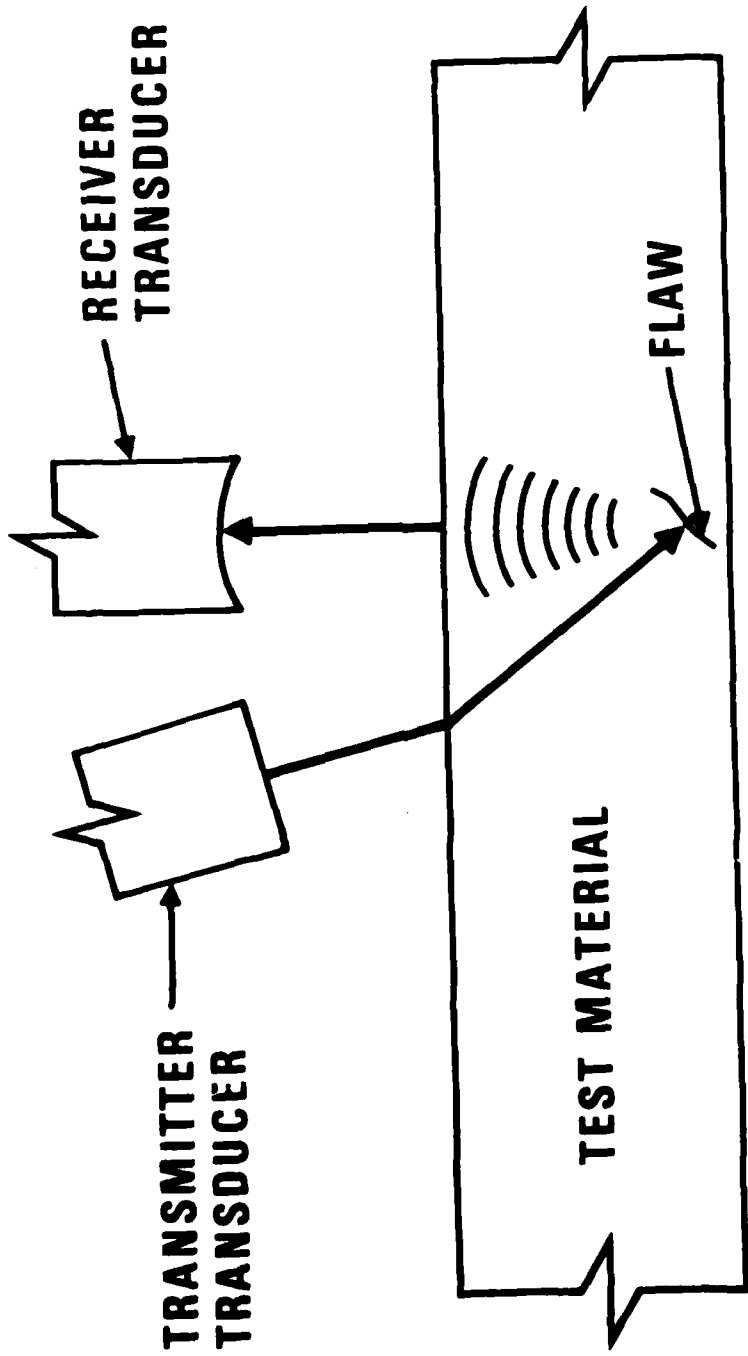

Figure 8. TYPICAL DELTA CONFIGURATION

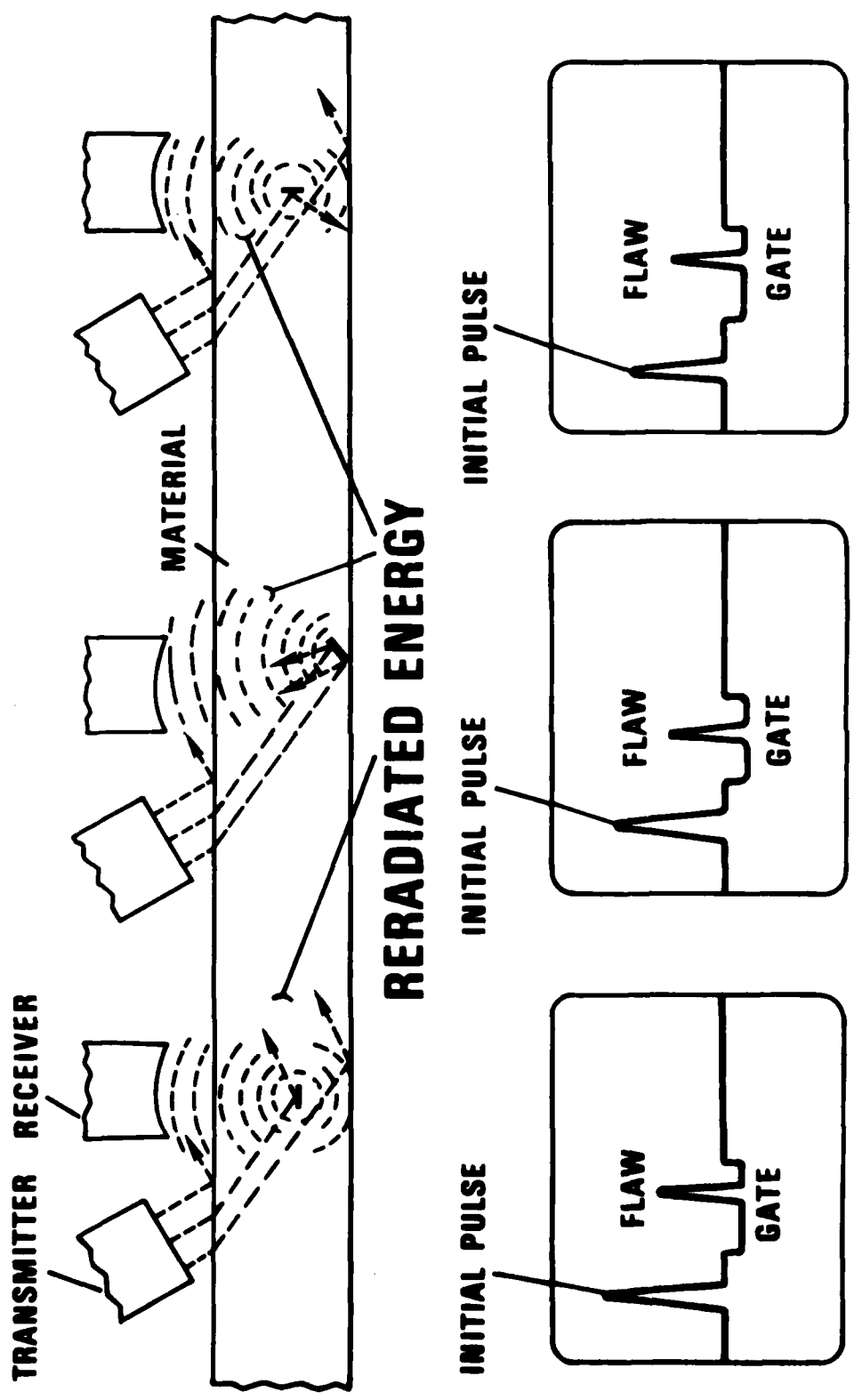

Figure 9. DELTA CRACK DETECTION CONCEPT

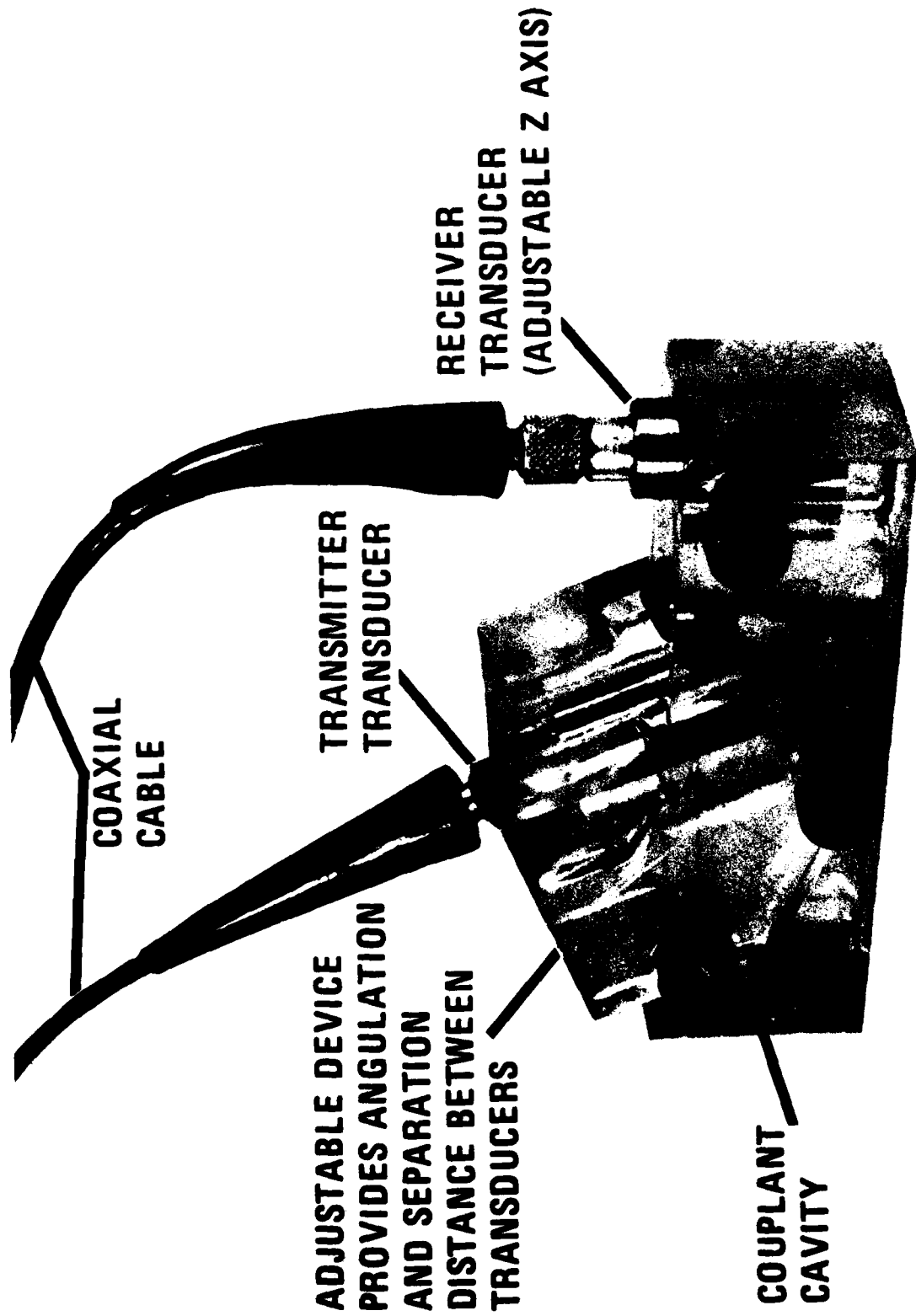
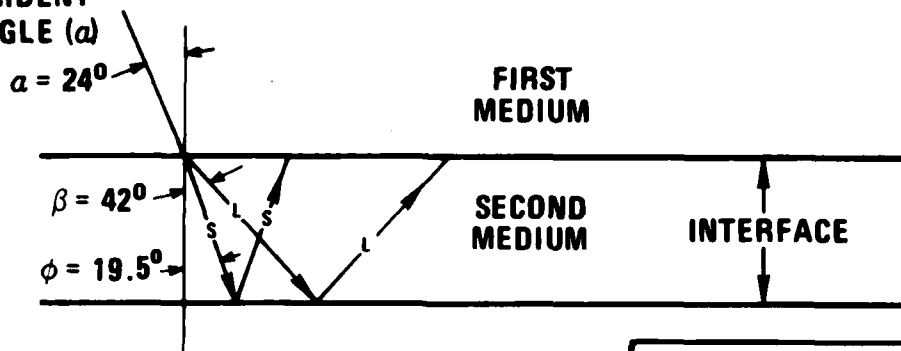

Figure 10. LABORATORY FIXTURING DEVICE - DELTA TECHNIQUE

INCIDENT ANGLE

INCIDENT ANGLE (α)



APPLYING SNELL'S LAW OF REFRACTION:

$$\frac{\sin \alpha}{V_C} = \frac{\sin \phi}{V_S} = \frac{\sin \beta}{V_L}$$

RESULTS IN REFRACTED ANGLE

(L) = 42° LONGITUDINAL MODE

(S) = 19.5° SHEAR MODE

VELOCITIES (IN./SEC $\times 10^5$):

ACRYLIC (STRETCHED)

$V_L = 1.05$

$V_S = 0.441$

ACRYLIC (CAST)

$V_L = 1.09$

$V_S = 0.560$

COUPLANT (OIL)

$V_L = 0.685$

SOUND ENERGY PATTERN

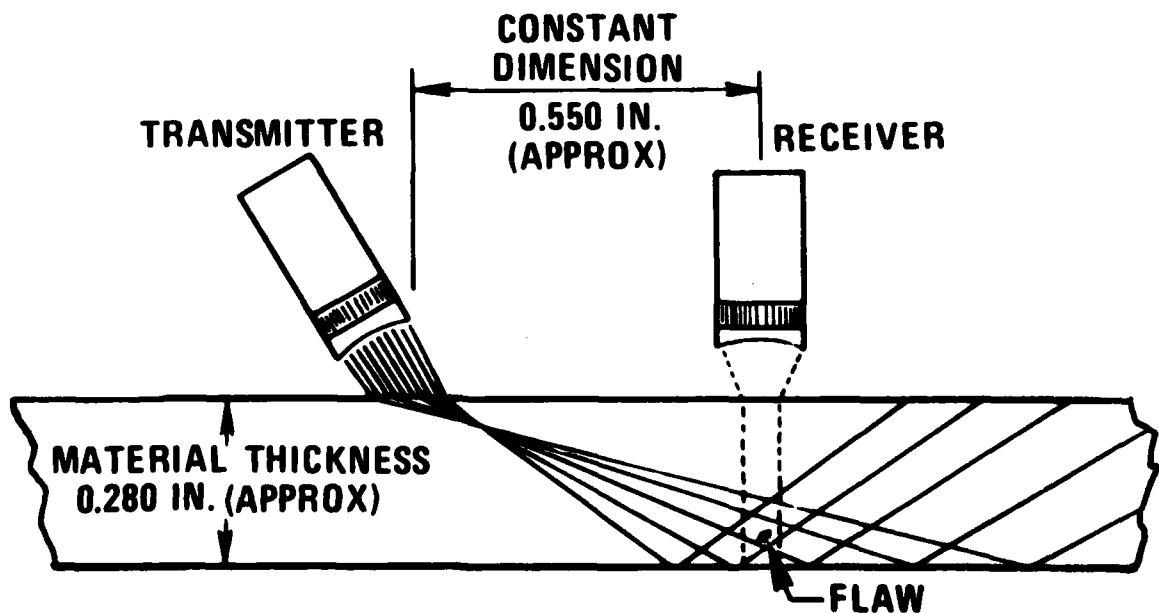

Figure 11. OPTIMIZING DELTA CONFIGURATION

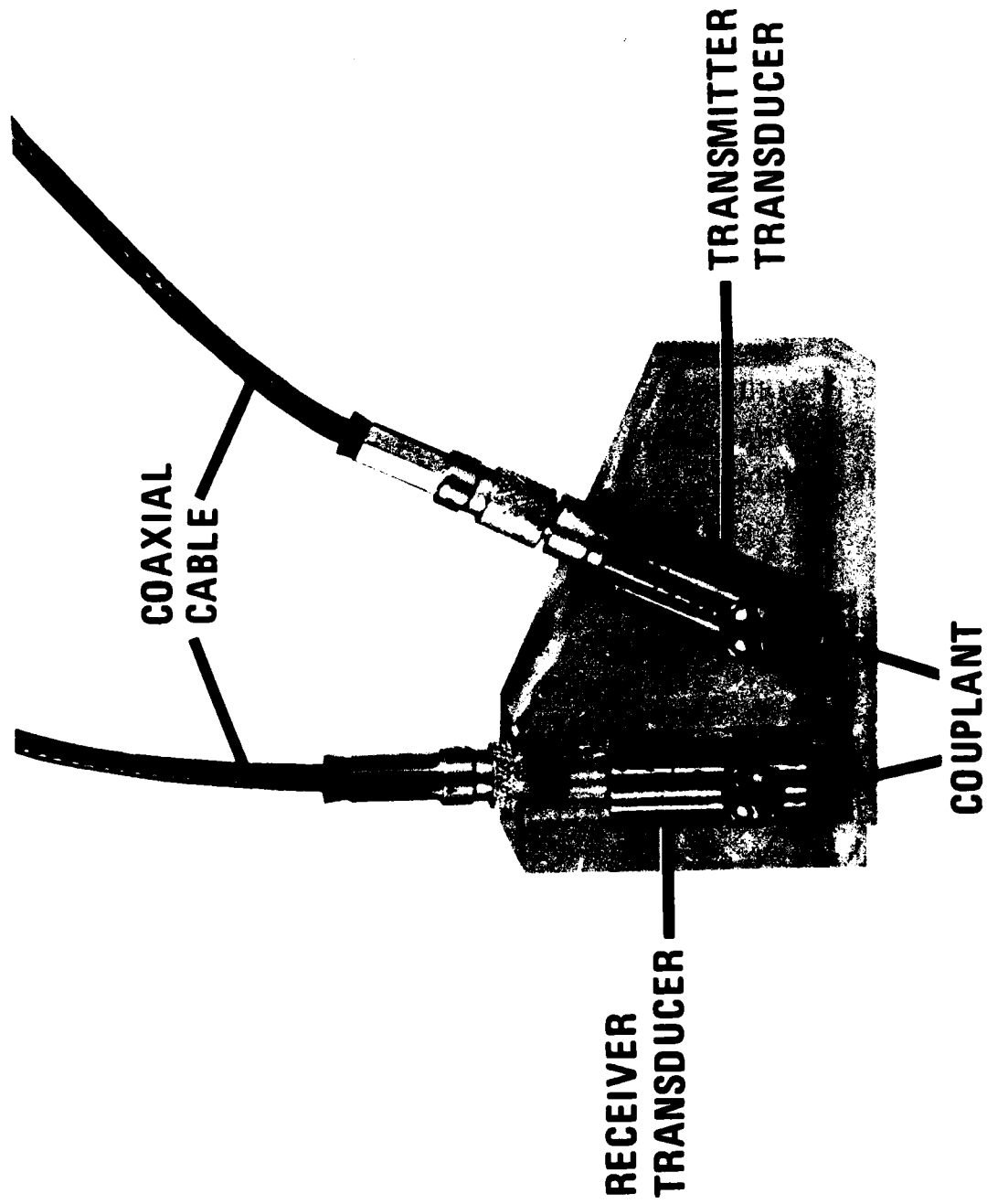
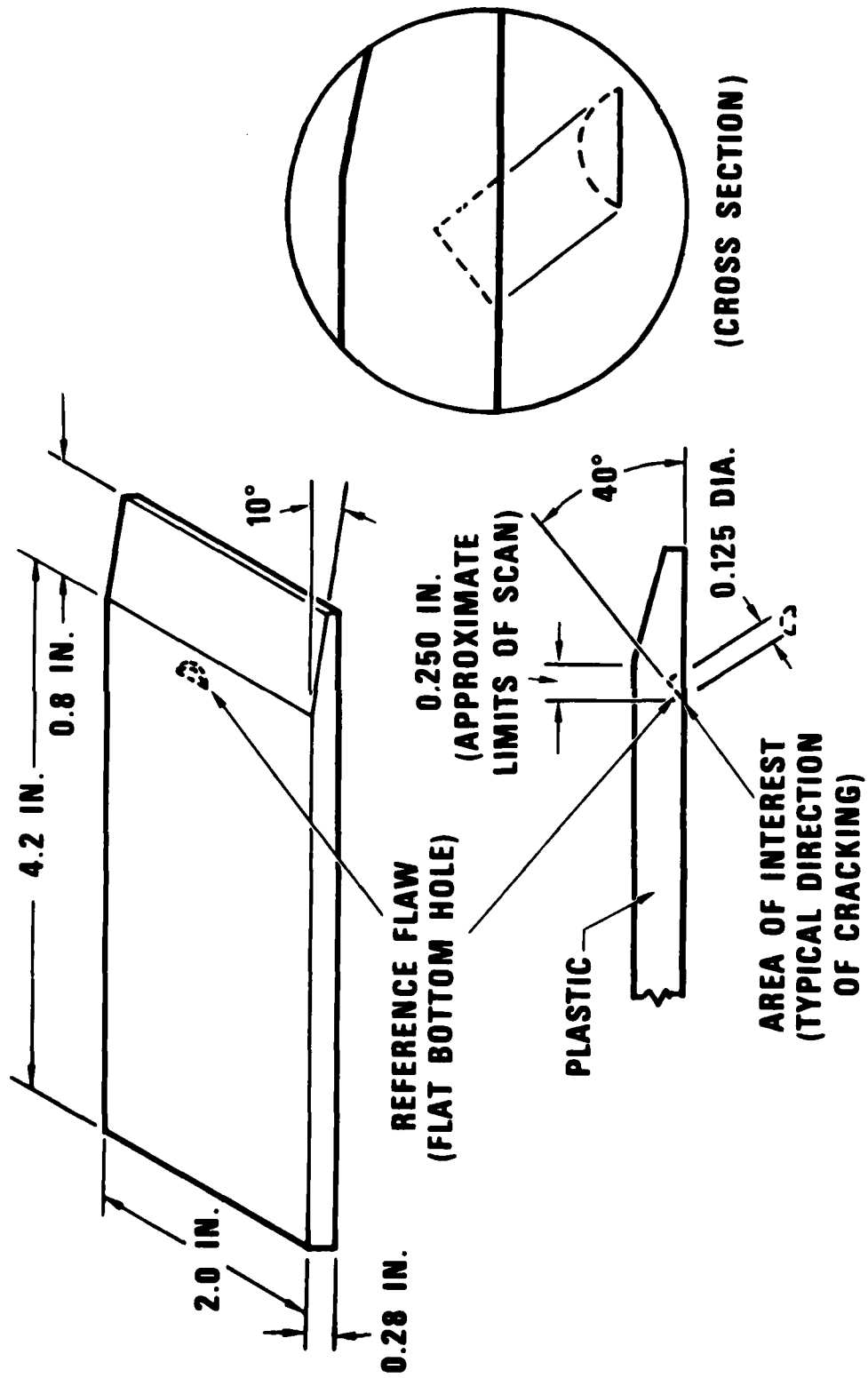

Figure 12. TRANSDUCER HOLDER - DELTA TECHNIQUE



327

Figure 13. REFERENCE STANDARD - DELTA TECHNIQUE

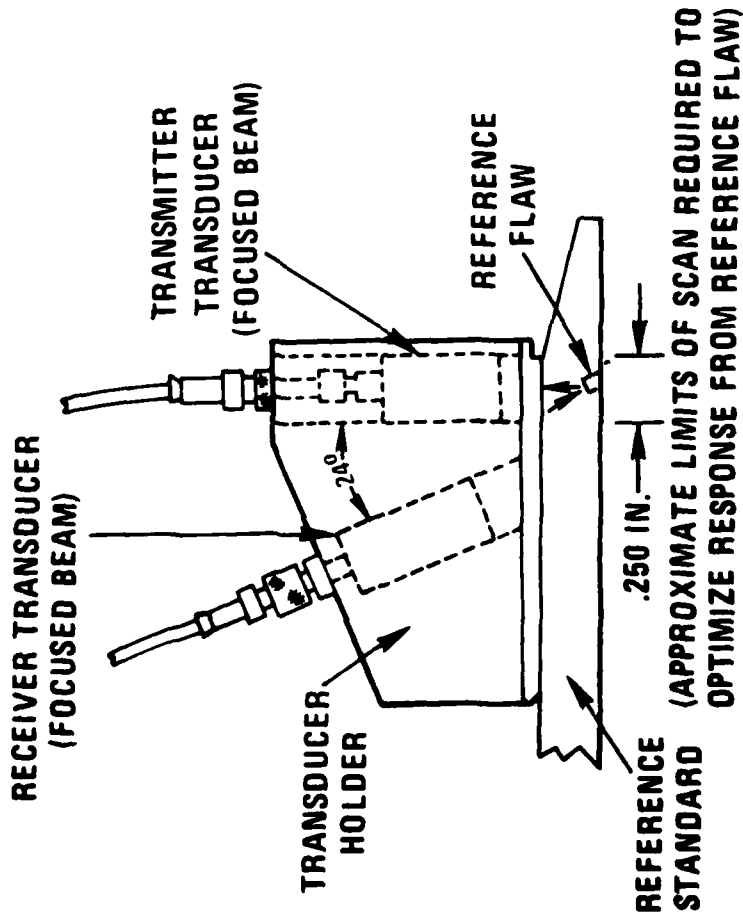
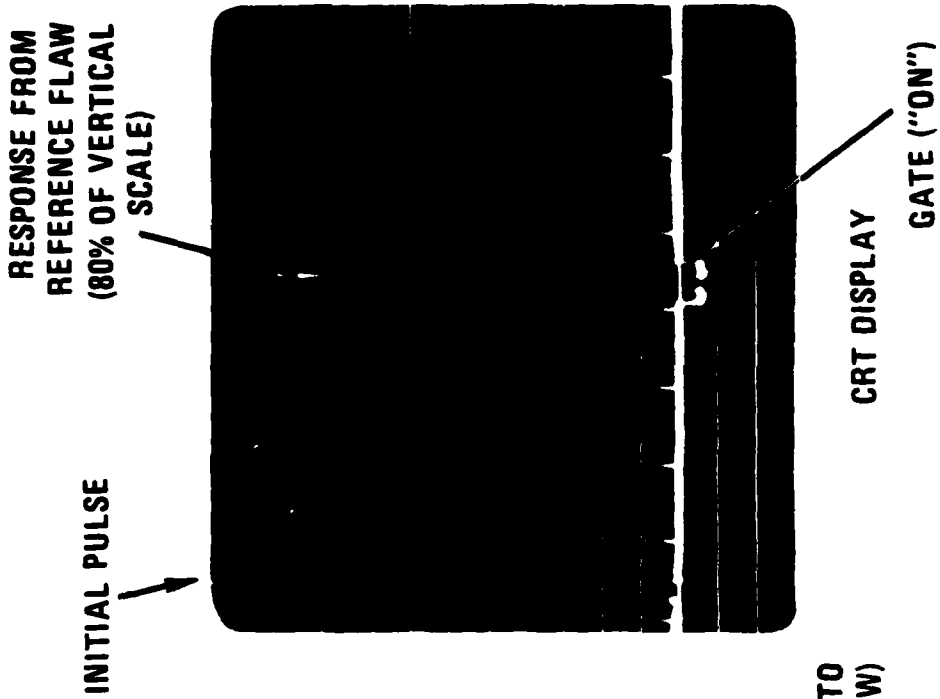

Figure 14. TYPICAL CRT SCREEN PRESENTATION - STANDARDIZING DELTA TECHNIQUE

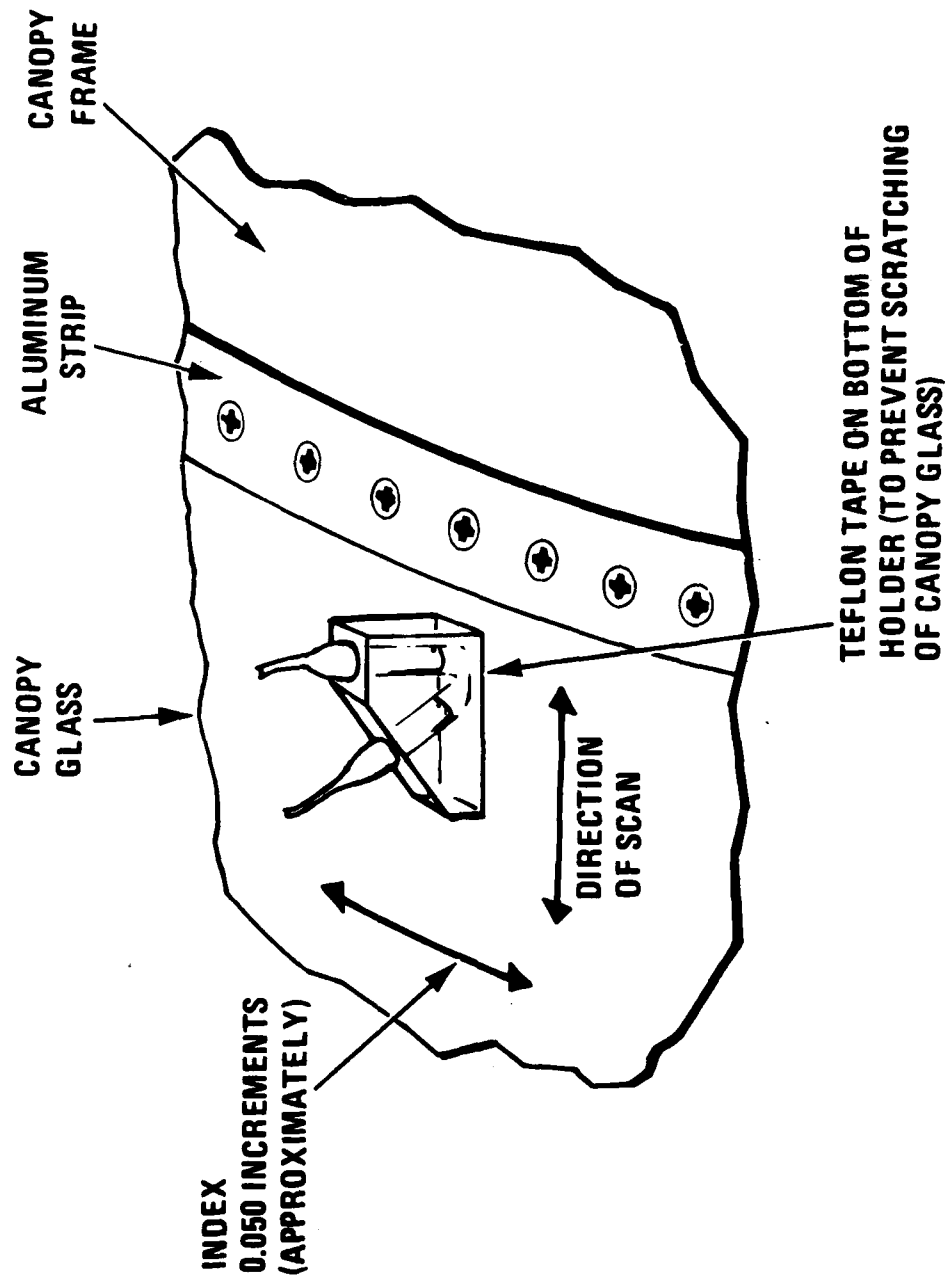

Figure 15. TYPICAL PLACEMENT OF TRANSDUCER HOLDER ON AREA OF INSPECTION - DELTA TECHNIQUE

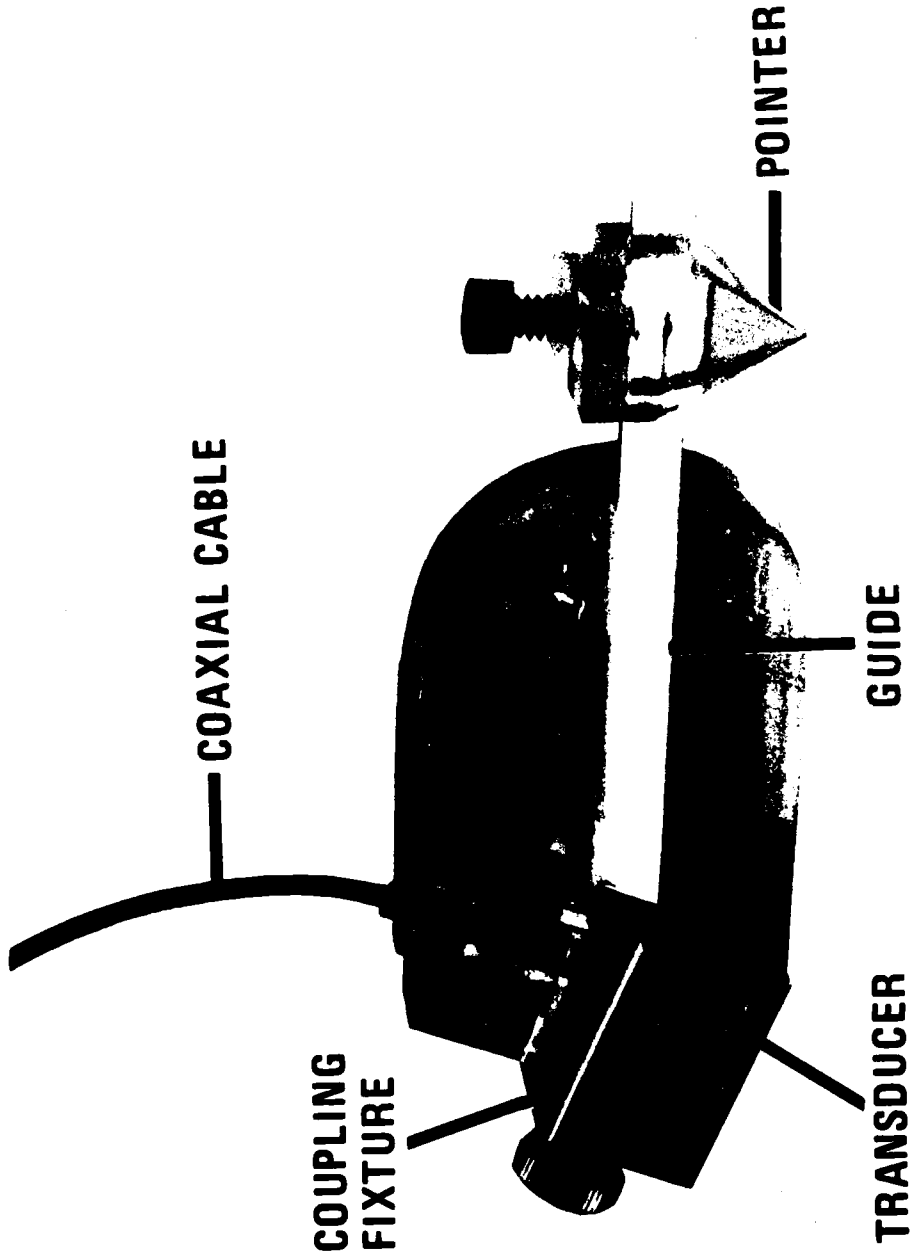
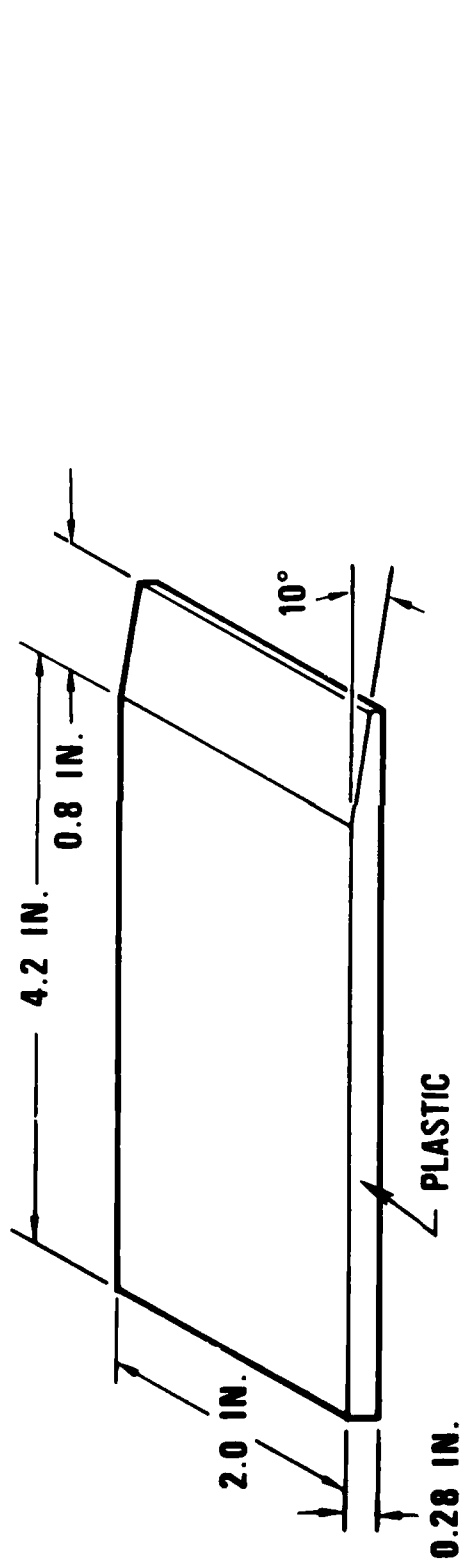

Figure 16. TRANSDUCER HOLDER - ANGLE BEAM TECHNIQUE



APPROXIMATE LIMITS OF SCAN
(AS INDICATED BY POINTER)

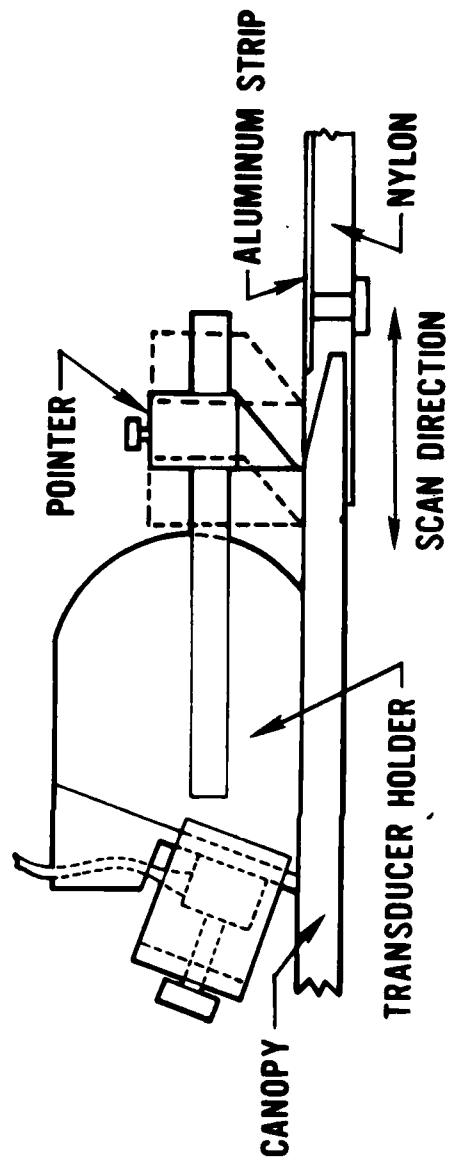

Figure 17. REFERENCE STANDARD - ANGLE BEAM TECHNIQUE

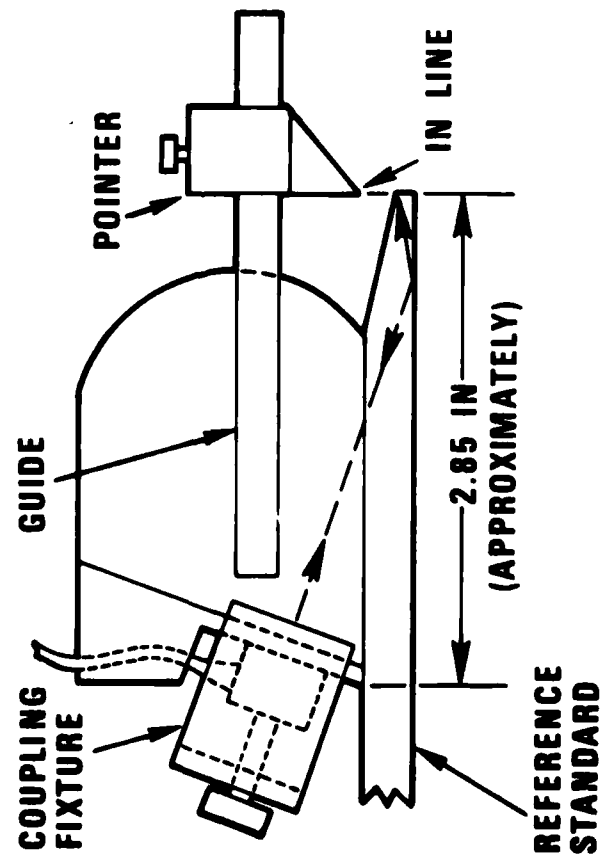
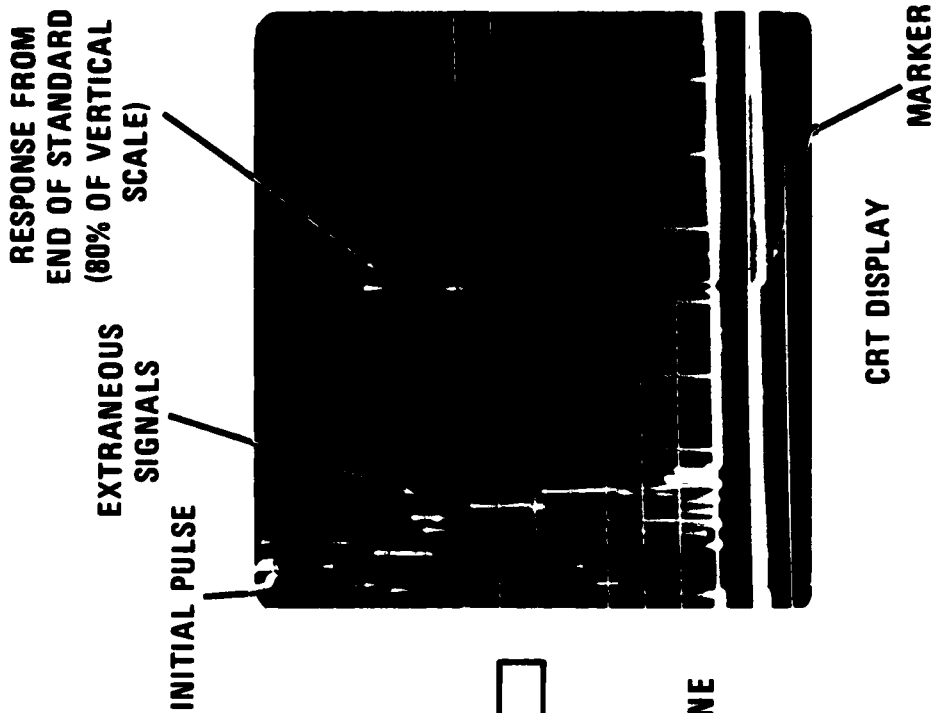

Figure 18. TYPICAL CRT SCREEN PRESENTATION - ANGLE BEAM TECHNIQUE

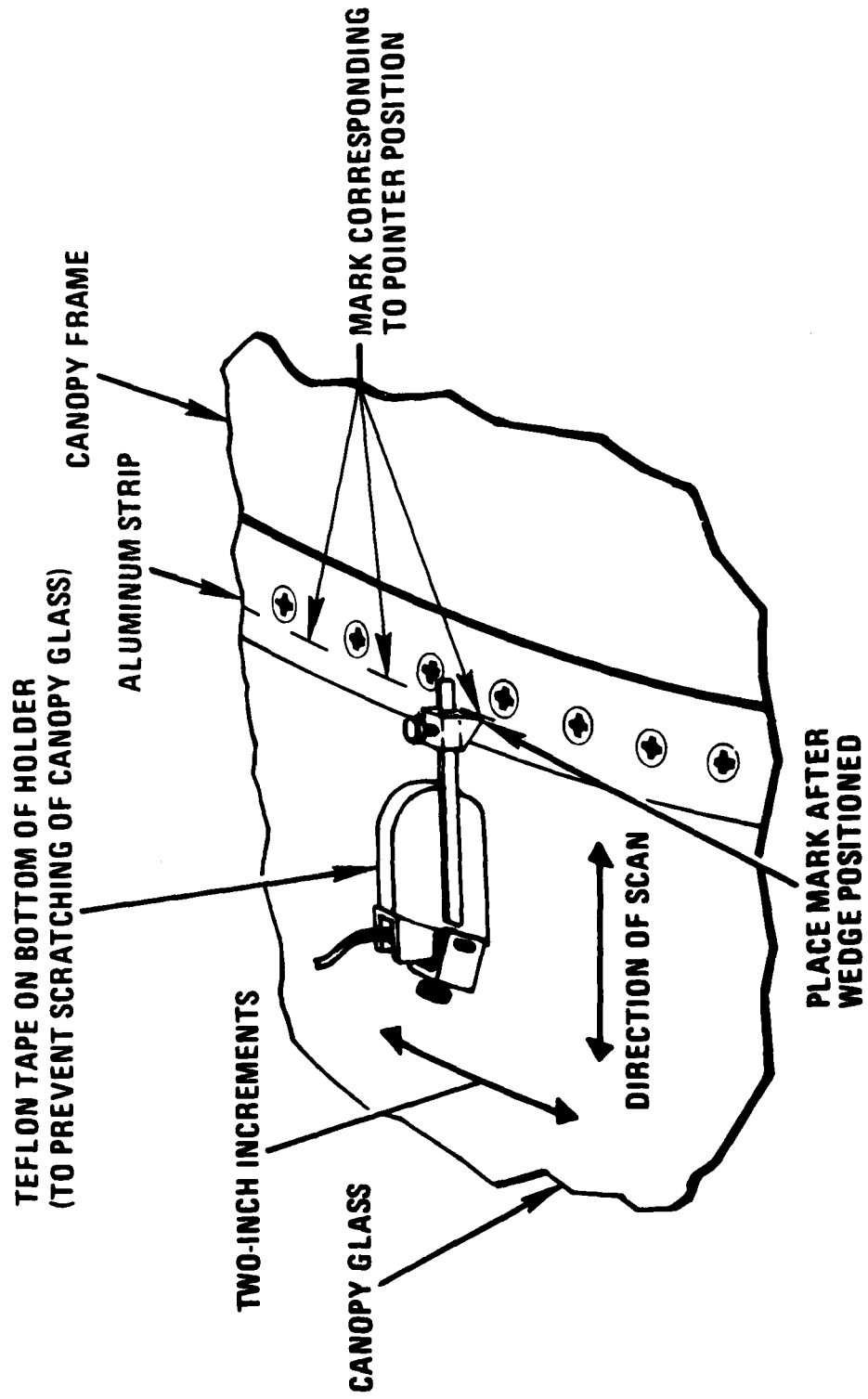

Figure 19. TYPICAL PLACEMENT OF TRANSDUCER HOLDER ON AREA OF INSPECTION - ANGLE BEAM TECHNIQUE