

AD-A092 985

OREGON STATE UNIV CORVALLIS SCHOOL OF OCEANOGRAPHY F/G 13/10
EXPOSURE, A NEWSLETTER FOR OCEAN TECHNOLOGISTS, VOLUME 8, NUMBE--ETC(U)
NOV 80 R MESECAR N00014-79-C-0004

NL

UNCLASSIFIED

1 4 1
AD
A1-405



END
DATE
FILED
1 81
DTIC

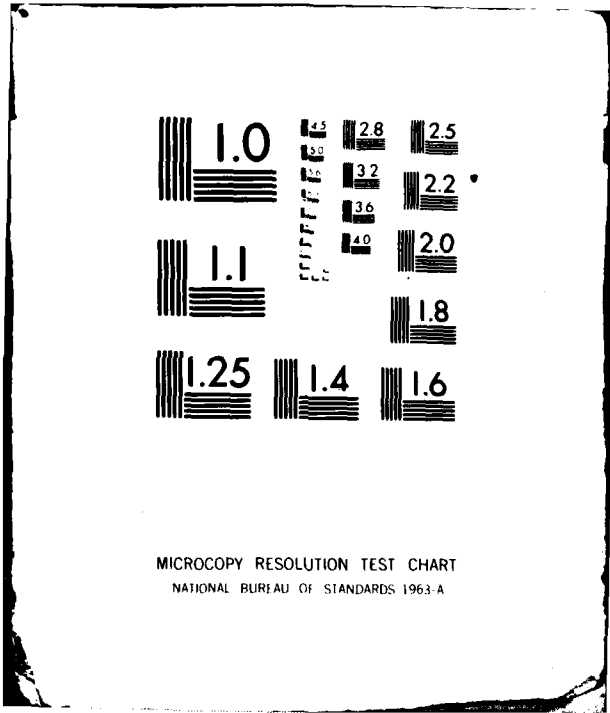

MICROCOPY RESOLUTION TEST CHART
NATIONAL BUREAU OF STANDARDS 1963-A

LEVEL III

4091555 (12)

Unlimited

SECURITY CLASSIFICATION OF THIS PAGE (When Data Entered)

AD A 092985

REPORT DOCUMENTATION PAGE		READ INSTRUCTIONS BEFORE COMPLETING FORM
1. REPORT NUMBER Vol 8, No. 5	2. GOVT ACCESSION NO. AD-A092985	3. RECIPIENT'S CATALOG NUMBER
4. TITLE (and Subtitle) EXPOSURE, A Newsletter for Ocean Technologists. Volume 8, Number 5.		5. TYPE OF REPORT & PERIOD COVERED technical report.
6. AUTHOR(S) Dr. Roderick Mesecar (ed.)		7. PERFORMING ORG. REPORT NUMBER N00014-79-C-0004
8. PERFORMING ORGANIZATION NAME AND ADDRESS School of Oceanography Oregon State University, Corvallis, OR 97331		9. PROGRAM ELEMENT, PROJECT, TASK AREA & WORK UNIT NUMBERS NR 083-103
10. CONTROLLING OFFICE NAME AND ADDRESS NORDA, NSTL Bay St. Louis, MS 39520, Attn: Code 410		11. REPORT DATE November 1980
12. MONITORING AGENCY NAME & ADDRESS (if different from Controlling Office)		13. NUMBER OF PAGES 8
14. DISTRIBUTION STATEMENT (of this Report) Approved for public release; distribution unlimited		15. SECURITY CLASS. (of this report) U
16. SUPPLEMENTARY NOTES Published every two months by the School of Oceanography Oregon State University, Corvallis, OR 97331		17. DECLASSIFICATION/DOWNGRADING SCHEDULE
18. KEY WORDS (Continue on reverse side if necessary and identify by block number) Ocean technology; instrumentation		19. DTIC ELECTE S DEC 16 1980 D
20. ABSTRACT (Continue on reverse side if necessary and identify by block number) A Dissolvable Link Release Mechanism The Woods Hole "MACE" Anchor		20. DISTRIBUTION STATEMENT (of the abstract entered in Block 20, if different from Report) E
21. Accession For NTIS GRA&I <input checked="" type="checkbox"/> DDC TAB <input type="checkbox"/> Unannounced <input type="checkbox"/> Justification <input type="checkbox"/>		22. By Distribution/ Availability Codes Dist. Avail and/or special A

DDC FILE COPY

DD FORM 1 JAN 73 1473

EDITION OF 1 NOV 65 IS OBSOLETE
S/N 0102-014-6601

Unclassified
SECURITY CLASSIFICATION OF THIS PAGE (When Data Entered)

EXPOSURE

vol. 8 no. 5

a newsletter for ocean technologists

A Dissolvable Link Release Mechanism

The Massachusetts Institute of Technology Seismology Laboratory has been building and deploying ocean bottom seismometer (OBS) systems for several years. We recently developed a free-fall system with an external geophone package. The geophone array, housed in a cylindrical pressure case, is deployed onto the ocean floor from the main instrument package after the main package settles on the bottom. The deployed geophone package (DGP) is attached to the end of a deployment arm and held against the body of the main OBS package during descent. After the main OBS package arrives on the bottom, the deployment arm releases, allowing the DGP to fall away from the main instrument and to settle some distance away (~ 1 meter). After the DGP is settled into place, the deployment arm detaches itself from the DGP and retracts to its original position, allowing the DGP to be connected to the main OBS by only a connecting cable.

A method was needed by which the deployment arm could be released and allowed to fall sometime after the whole instrument had been launched at the sea surface. Since the time of the actual release was not critical (between 2 and 8 hours after initial deployment), the release mechanism did not have to be particularly sophisticated. However, the device had to be extremely reliable; neither releasing too soon (before the instrument arrived on the bottom), nor too late (after the instrument had begun to record data). Also the link had to be strong enough to carry the combined weight of the DGP and the deployment arm, as well as the additional handling stresses associated with the launching from the deck of the ship.

Several ideas were considered, including a dissolvable magnesium link, a "burn" wire, and dissolvable plastic. All of these methods were found to be either too awkward to implement or too unreliable.

November 1980

80 12 15 001

The idea was suggested that a device using sugar could be used since solid sugar readily dissolves in water. The idea was to fill up a short piece of electrical conduit with a sugar slurry made from ordinary refined sugar and water, insert a small diameter rod into the center (longer than the piece of conduit), and allow the sugar mixture to harden. It was discovered that the sugar slurry would not harden sufficiently. We then tried melted sugar without water. Once the sugar had cooled, it became extremely hard and could be subjected to a considerable amount of physical stress before breaking down.

The design that we currently use consists of a piece of 1/2-inch EMT electrical conduit about 3 inches long and a piece of 1/4-20 threaded rod about 5 inches long (Figure 1). The rod is inserted into the tube in such a way that it is centered. The extra length protrudes out of one end of the tube with a slight indentation at the other end (about 1/4 inch). The tube is then filled with molten sugar and allowed to cool.

After the sugar has hardened, two diametrically opposed holes are drilled in the tube at the end with the indented rod so that a piece of strong, rigid wire can be attached (we found that ordinary coat hanger wire was very useful here). The deployment arm could then be attached to one end of the tube via the wire and the other end could be secured to the main instrument package with the protruding end of the threaded rod and a 1/4-20 nut (see Figure 2).

It is a little tricky to hold the threaded rod in the correct position inside the tube before the sugar is added. We solved the problem by making a fixture to hold the tube

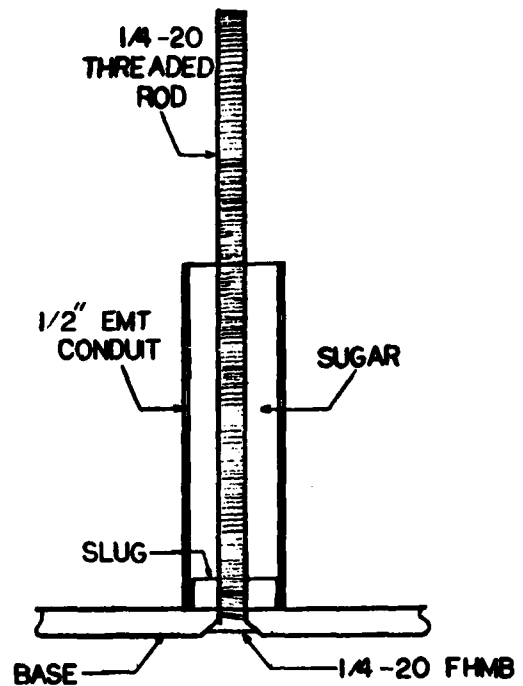

Figure 1. Assembly fixture used to support release parts in place.

and rod in place. A cylindrical piece of aluminum about 1/4-inch long is machined so that the diameter is slightly smaller than the I.D. of the conduit. A 1/4-20 threaded hole is tapped through the center of the piece. This slug is then secured to a scrap piece of .250-inch aluminum using a 1/4-20 flat head machine bolt from underneath. The length of the bolt is adjusted so that only a couple of threads in the slug show from the top. The piece of threaded rod to be used is inserted into the tapped hole and secured in place with 1/2 turn. (Note: if the end of the threaded rod and the end of the flat head bolt are filed flat, the threaded rod will stand straight when it is set in place). The piece of conduit can then be slipped over



Figure 2. Installed RELEASE supporting deployment arm and DGP up against main instrument package.

the threaded rod and seated down onto the slug. The rod will then be correctly oriented inside the tube (see Figure 1).

Refined sugar is then heated up in a saucepan (we found that sugar should be heated up so that all of the granules are completely melted, and the sugar begins to boil). The melted sugar is poured into the tube, filling it completely. After the sugar is thoroughly cooled, the release can then be removed simply by unscrewing the cylinder. (Note: if there is difficulty removing the completed release from the fixture, a little heat applied from a heat gun will usually free it up.)

The releases were subjected to a variety of tests to determine what factors would influence the rate of dissolving. Effects of water salinity, pressure, current, and release configuration were tested.

In a large plastic garbage pail filled with water, a release was suspended in the water from a piece of wood straddling the pail. A weight was

attached to the other end simulating the combined weight of the DGP and the deployment arm. A motor revolving at a very low RMP, with a vane attached to the shaft, was also suspended in the water to simulate current movement. The release was tested with and without this current generation. The presence or lack of current seemed to make little difference--the sugar would barely dissolve even after several days.

Releases were then tested in our pressure test chamber. A release was fitted into a test fixture that placed the stress of the approximate combined weight of the DGP and deployment arm on it. (Two releases could be tested simultaneously.) A small gauge wire was placed across the device so that when a release occurred, the wire would break, creating an open circuit to a continuity tester outside the test chamber. In this way, we could tell at what time a release occurred. The whole fixture was then placed inside a one gallon propylene lab jar filled with water and this in turn was placed inside the test

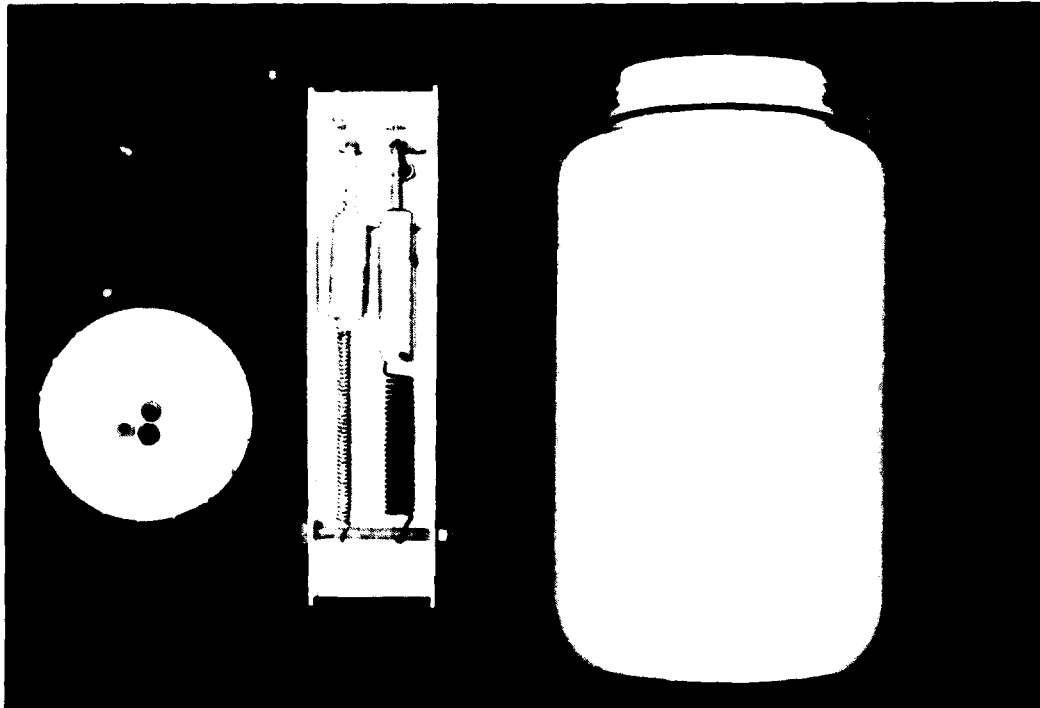

Figure 3. Test fixture used for pressure testing.

chamber (see Figure 3). The first experiment used fresh water in the jar at an initial temperature of 0°C. Two releases with 3-inch tubes were tested. In one release a small hole was drilled in the center of the tube allowing sugar at the middle of the release to be exposed to water as well as at either end. The second release had no holes drilled in it. The pressure was increased to 8000 psi over a 1-hour period, simulating a descent in the ocean. The release with one hole took 2 hours to release, while the one with no holes took 2-3/4 hours to release.

Other tests followed using salt water and other pressure schedules (see Table I for results).

The results seemed to indicate that pressure had the most dramatic effect on release time. A

difference between atmospheric pressure and 3000 psi showed the greatest change. (No release versus 3-4 hours at 3000 psi). Pressure increases above that seemed to reduce the release time only slightly. Salinity also had some effect, increasing the release time from what it would be in fresh water. (Note: the reason for the apparent premature release time in the fourth test listed in the Table remains a mystery. It is possible that too many air bubbles became trapped in the sugar used in that particular release. The high pressure would then crush a good portion of the sugar, causing a premature release. More testing of this phenomenon needs to be done.)

For a given configuration and water salinity, temperature, and pressure (greater than 3000 psi), we concluded that the device could be

Release Configuration	Test Pressure (psi)	Time to Test Pressure (Minutes) *	Water	Initial Temperature (°C)	Final Temperature (°C)	Time to Release
3" Tube - 1 Hole in Ctr.	8000	60	Fresh	0	10	2 Hrs.
3" Tube - No Holes	8000	60	Fresh	0	10	2 Hrs. 45 Mins.
3" Tube - No Holes	5000	20	Salt	0	12	3 Hrs. 30 Mins.
3" Tube - No Holes	5000	20	Salt	0	12	3 Hrs. 38 Mins.
2" Tube - No Holes	5000	20	Salt	0	13	3 Hrs. 35 Mins.
3" Tube - No Holes	5000	20	Salt	0	13	4 Hrs. 45 Mins.
2" Tube - No Holes	8000	40	Salt	0	14	3 Hrs. 52 Mins.
3" Tube - No Holes	8000	40	Salt	0	14	4 Hrs. 40 Mins.
2" Tube - No Holes	3000	10	Salt	0	12	4 Hrs.
3" Tube - No Holes	3000	10	Salt	0	12	4 Hrs. 45 Mins.

*Test pressure maintained until release.

Table I. Pressure testing results

relied upon to release within plus or minus 30 minutes of the expected release time. Since water temperature is not a varying parameter in our application, no experiments were conducted testing for this effect.

We have successfully used these releases in 11 deployments of our instruments. We feel that this device has more than proven itself. One final note: since sugar is sensitive to moisture in the air, it is advisable to store these devices in an airtight container--preferably filled with desiccant. The releases should only be removed just prior to their use.

FOR FURTHER INFORMATION CONTACT:

Tim Barash
Room 37-484
Massachusetts Institute of Technology
Cambridge, MA 02139

Telephone: (617) 253-1708



Tim Barash is a Laboratory and Field Engineer in the Department of Earth and Planetary Sciences at Massachusetts Institute of Technology. He is primarily responsible for the maintenance and field installation of Ocean Bottom Seismometer systems used by the seismology group at MIT. He received a B.A. in Psychology from Lake Forest College, Lake Forest, Ill. in 1970. Prior to employment at MIT, Mr. Barash had worked in psychology research, motion picture technology, broadcast engineering, and medical instrument technology.

The Woods Hole "MACE" Anchor

The Woods Hole Oceanographic Institution's (WHOI) Buoy Group has recently developed and deployed a drag resistant, economical modification of their standard cast-iron cylindrical anchors¹ used for deep-ocean intermediate moorings (see Figure 1). The design concept, titled "Mace" anchor, can be easily applied to other dead-weight types of anchors.

Moorings designs were developed for an exploratory array of ten moorings to be deployed in the western Pacific across the Kuroshio Extension Current. These moorings were to be approximately 5750 meters long and moored in 6 kilometers of water. The WHOI mooring-design computer analysis program ("NOYFB") indicated the combined static and dynamic anchor loading exceeded the dead weight horizontal holding power of the 3000 lb (wet) cast-iron cylinder anchor. Computed drag forces, for various Kuroshio current velocity profiles, indicated the need for a much heavier anchor. Using a larger anchor, however, would necessitate a larger diameter wire to withstand launch transient tensions, which would then require more flotation to maintain optimum wire tension and total mooring dynamic performance.

¹Peter R. Clay, "Modular Anchor System" *Exposure IV* (4), p 5.



Figure 1. A "MACE" anchor with three cast cylinders (each weighs 1000 lb, wet). The 40-lb Danforth anchor is secured to the lower eye nut with 2 m of 3/8-in. chain and is lashed to the clump with a magnesium link.

The added flotation and larger wire would result in more drag and thus require a still larger anchor, etc.

For many years an auxiliary Danforth anchor has been attached to clump anchors with chain and lashed with dissolvable rope (or magnesium link) to prevent entanglement on the way to the bottom. The Danforth anchor was added to the clump anchor for anchor station insurance, not as a designed feature of the anchor. In the Pacific deployment a small 40-lb Danforth is still used as insurance but the main holding power is provided by flukes added to the clump anchor.

Figure 2 is a schematic drawing showing the fluke plates that are added to the cast-iron cylinders.

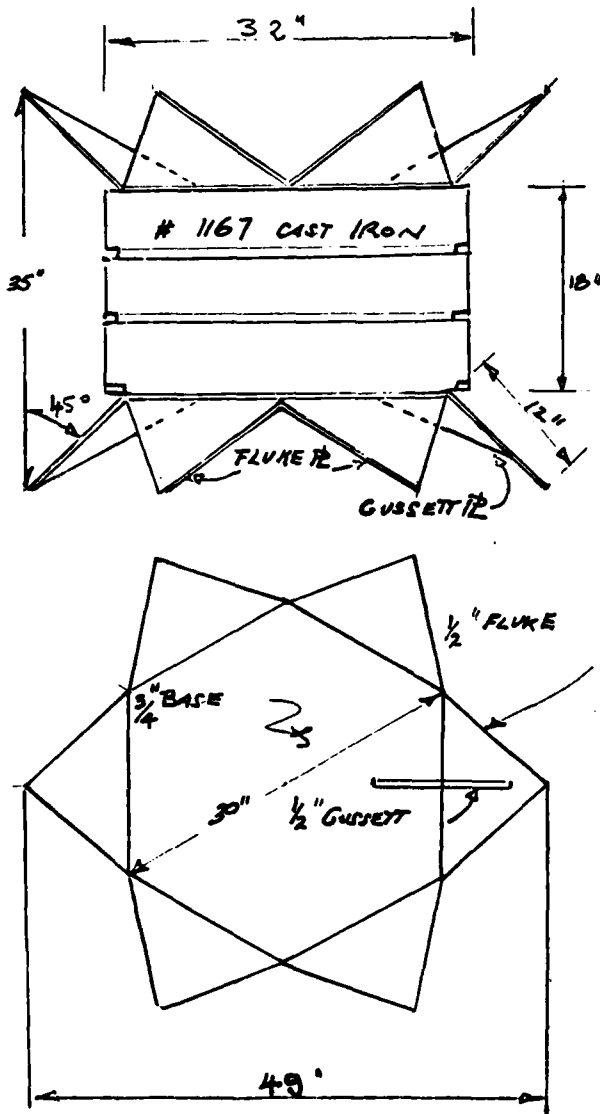

Figure 2. Schematic drawing showing fluke plates that are added to the cast-iron cylinders.

Individual cylinders of 500, 1000, 1500 and 2000 lb (wet) can be stacked to build the size of anchor desired. In the Pacific deployment, three 1000-lb modules were used. The fluke plates simply have a hole through which a standard Crosby galvanized 1 1/4-inch-diameter eye bolt goes. The bolt then passes through the cylinders, through a duplicate plate, and is held on with a Crosby galvanized eye nut which is welded on

for extra security. The chain of an auxiliary Danforth anchor is then attached to the eye nut.

In this design the base was made from 3/4-inch steel plate and the gussets and flukes of the fluke plates were made from 1/2-inch steel plate, shear cut and welded in the WHOI shop. The 1/2-inch-thick flukes are sufficient to support the entire anchor weight (3300 lb). Various thicknesses, shapes, and arrangements could be utilized along with selecting cylinder sizes to match just about any desired design wet weight. Anchor concept studies and model tests were made by Henri Berteaux of the WHOI Ocean Engineering Department.

A few thoughts on why the pointed flukes of the anchor point in opposite directions on each end might be of interest. If the bottom is hard and rocky, the bottom points keep the center of gravity of the anchor high, aiding its ability to tip over and dig the top flukes in, plow fashion. If on descent, or during the year or more that the anchor is on station, the 1/2-inch chain section above the anchor becomes fouled on the flukes on either end, the direction of pull will tend to imbed at least one set of flukes. The angles of the flukes and their number insure that at least two on each end will be in contact with the bottom (a four-fluke anchor might have only one fluke in the sea floor). A cone design in place of individual flukes would not penetrate hard or gravel bottoms, would descend slower, perhaps cartwheel at launch, and would be expensive and difficult to fabricate.

Although the fluke plates make the anchor assembly large, they stack neatly in boxes for shipping. Assembly at a foreign port can be easily done with only a fork-lift truck.

of the anchor
"ace" components are
ne WHOI Buoy Group.
a railroad-wheel
flukes can be welded
size of the railroad
plates does make it
y.

en supported by the
Research Contract
, NR 083-400.



Keith Bradley is
a research assoc-
iate and manager
of the Woods
Hole Oceanographic
Institution's
Buoy Group Oper-
ations section.
He is a former
Coast and Geo-
detic Survey
officer (now NOAA).
He has a B.S. degree

in mechanical engineering from the
University of Notre Dame, a M.S.E.
(mechanical engineering) from the
University of Michigan, was an
automotive development engineer for
5 years, and has been at WHOI for the
past 6 years.

RMATION, CONTACT:

, Manager
Group
ographic Institution
02543

) 548-1400
01

T A B L E O F C O N T E N T S

<i>rticle</i>	<i>Author</i>
olvable Link Release Mechanism	Barash
ods Hole "Mace" Anchor	Bradley

tor
hy
ity

ASS MAIL