

AD-A093 198

INSTITUTE FOR DEFENSE ANALYSES ARLINGTON VA SCIENCE A--ETC F/6 22/2  
CONTINUING ISSUES (FY 1979) REGARDING DOD USE OF THE SPACE TRAN--ETC(U)  
DEC 79 R G FINKE, C J DONLAN, G W BRADY MDA903-79-C-0018

UNCLASSIFIED

IDA-P-1451

IDA/HQ-79-21729

NL

1 of 2  
AD-A093 198



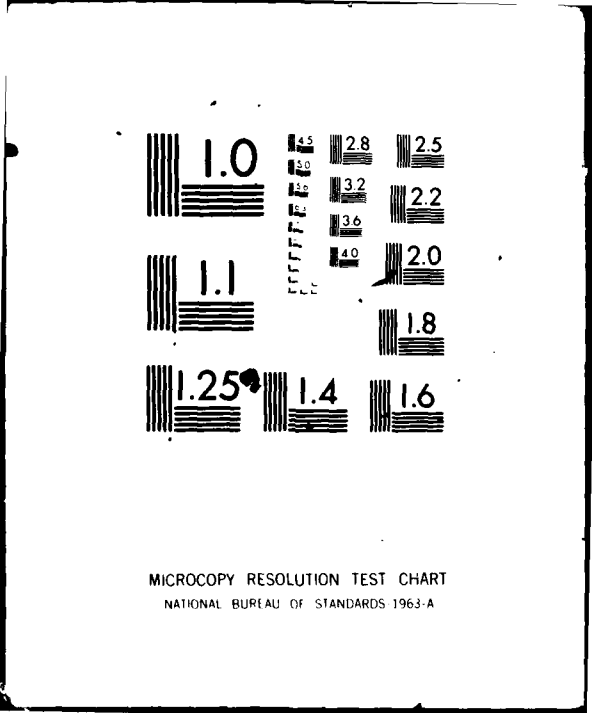

MICROCOPY RESOLUTION TEST CHART  
NATIONAL BUREAU OF STANDARDS 1963-A

12



AD A 093198

IDA PAPER P-1451

# CONTINUING ISSUES (FY 1979) REGARDING DoD USE OF THE SPACE TRANSPORTATION SYSTEM

Reinald G. Finke  
Charles J. Donlan  
George W. Brady

December 1979

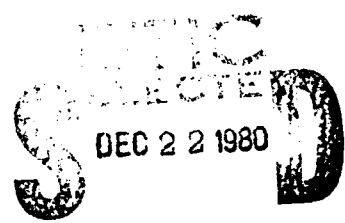

A

Prepared for  
Office of the Under Secretary of Defense for Research and Engineering

ADJ FILE COPY



INSTITUTE FOR DEFENSE ANALYSES  
SCIENCE AND TECHNOLOGY DIVISION

80 12 17 007

The work reported in this document was conducted under contract MDA 903 79 C 0018 for the Department of Defense. The publication of this IDA Paper does not indicate endorsement by the Department of Defense, nor should the contents be construed as reflecting the official position of that agency.

# UNCLASSIFIED

SECURITY CLASSIFICATION OF THIS PAGE (When Data Entered)

REPORT DOCUMENTATION PAGE		READ INSTRUCTIONS BEFORE COMPLETING FORM
1. REPORT NUMBER	2. GOVT ACCESSION NO. <i>AD-AC 93 198</i>	3. RECIPIENT'S CATALOG NUMBER
4. TITLE (and Subtitle) Continuing Issues (FY 1979) Regarding DoD Use of the Space Transportation System	5. TYPE OF REPORT & PERIOD COVERED FINAL Oct. 1978 - September 1979	
	6. PERFORMING ORG. REPORT NUMBER IDA Paper P-1451	
7. AUTHOR(s) Reinold G. Finke, Charles J. Donlan, George W. Brady	8. CONTRACT OR GRANT NUMBER(s) MDA 903 79 C 0018	
	9. PERFORMING ORGANIZATION NAME AND ADDRESS Institute for Defense Analyses / 400 Army-Navy Drive Arlington, VA 22202	
11. CONTROLLING OFFICE NAME AND ADDRESS Director, Offensive and Space Systems, OUSDRE The Pentagon Washington, D.C. 20301	10. PROGRAM ELEMENT PROJECT TASK AREA & WORK UNIT NUMBERS Task T-9-047	
	12. REPORT DATE December 1979	
13. MONITORING AGENCY NAME & ADDRESS (if different from Controlling Office) DoD-IDA Management Office, OUSDRE 400 Army-Navy Drive Arlington, VA 22202	11. NUMBER OF PAGES 108	
	15. SECURITY CLASS. (of this report) Unclassified	
16. DISTRIBUTION STATEMENT (of this Report)  Approved for public release; distribution unlimited.		
17. DISTRIBUTION STATEMENT (of the abstract entered in Block 20, if different from Report)  None		
18. SUPPLEMENTARY NOTES  N/A		
19. KEY WORDS (Continue on reverse side if necessary and identify by block number) space shuttles, spacecraft, space crews, space flight, military equipment, operation, propulsion systems, launching, payload, meteorological satellites		
20. ABSTRACT (Continue on reverse side if necessary and identify by block number) The purpose of this study was to assist the DoD by identifying, and suggesting possible means of resolution of, issues in the following areas of interest regarding military use of the Shuttle:  a. <u>Space Test Program (STP)</u> experiments in the sortie mode: review and examine supporting hardware characteristics and scheduling constraints.		

## UNCLASSIFIED

SECURITY CLASSIFICATION OF THIS PAGE (When Data Entered)

# UNCLASSIFIED

SECURITY CLASSIFICATION OF THIS PAGE/When Data Entered

20.

- b. Survivability of the Shuttle and other spacecraft: review vulnerability assessments to suggest possible survivability enhancement solutions.
- c. Mission 4 Performance: examine Shuttle modifications proposed to achieve the desired performance of DoD's Mission 4.
- d. Launch Facilities, Procedures: review and compare plans for launch facilities and procedures for handling the Shuttle and payloads at Vandenberg Air Force Base (VAFB) and the NASA Kennedy Space Center (KSC).
- e. Payload Integration: review and critique plans for conducting analytical integration of payloads with the Shuttle.
- f. Environmental Satellites: compare military and civil plans for meteorological and oceanographic satellites to identify opportunities and difficulties in combining future programs.

The salient observations on each of the above topics from the study were the following:

- a.
  - A significant contributor (up to 40 percent according to USAF and NASA estimates) to the cost of launching experimental payloads in the sortie mode is the analytical verification of compatibility ("integration") of the experiment with the Shuttle; the integration cost may be reduced by the Air Force by their proposed "class cargo" generalized integration analysis that, once done in detail, may not have to be repeated in such costly detail.
  - Choice of support structure for experiments will be made on the basis of compactness and light weight (for a given experimental weight) rather than on intrinsic cost, to minimize launch costs as computed by the NASA volume and weight formulas.
  - The preparations for the first STP sortie flight are running on a much tighter schedule than the equivalent NASA preparations for the first Spacelab flight in the same time period. STP should be encouraged to continue to investigate ways to reduce the schedule disparity by making use of NASA experience and hardware.
- b. A Space Division-funded Rockwell study of survivability had not been released by the Air Force during FY 1979 to allow an IDA review for inclusion in this paper. No substantive effort was expended on this subtask this year.
- c. The performance of the Shuttle will initially be inadequate to accomplish the military Mission 4. When weight-reduction efforts have been completed, two propulsion developments will be necessary to give the desired performance: (1) modifying the main engines for 109 percent thrust and (2) adding auxiliary boosters. A modified Mission 4, reduced in man-days on orbit rather than in payload, could be accomplished with either. NASA's plans for modifying the engines indicate qualification by the end of CY 1980; plans for liquid booster modules are on-going and they could be available before the first Mission 4 flight if required.
- d. Estimated required checkout times of military payloads exceed allowable pad occupancy times at KSC; modification of the Solid Motor Assembly Building, incorporating a facility for off-line payload-processing, appears to be the best solution.
- e. The cost of analytical integration procedures for an operational, autonomous satellite is estimated by the Air Force to be as much as 28 percent of the delivery cost. Cost savings are possible through reducing overlap in the overseeing organizations and reducing requirements for detail in analyses.
- f. Complete convergence of post-1985 military and civil environmental satellites appears to be feasible, with a potential IDA-estimated cost savings of from five to fifteen percent.

# UNCLASSIFIED

SECURITY CLASSIFICATION OF THIS PAGE/When Data Entered

IDA PAPER P-1451

**CONTINUING ISSUES (FY 1979) REGARDING DoD USE  
OF THE SPACE TRANSPORTATION SYSTEM**

Reinald G. Finke  
Charles J. Donlan  
George W. Brady

SEARCHED	<input checked="" type="checkbox"/>
SERIALIZED	<input type="checkbox"/>
INDEXED	<input type="checkbox"/>
FILED	<input type="checkbox"/>
DEC 1979	
FBI - ARLINGTON	

A

December 1979



INSTITUTE FOR DEFENSE ANALYSES  
SCIENCE AND TECHNOLOGY DIVISION  
400 Army-Navy Drive, Arlington, Virginia 22202

Contract MDA 903 79 C 0018  
Task T-9-047

RE: IDA Paper P-1451, Classified References,  
Distribution Unlimited-  
No change per Ms. Warden, IDA

## ABSTRACT

The purpose of this study was to assist the DoD by identifying, and suggesting possible means of resolution of, issues in the following areas of interest regarding military use of the Shuttle:

- a. Space Test Program (STP) experiments in the sortie mode: review and examine supporting hardware characteristics and scheduling constraints.
- b. Survivability of the Shuttle and other spacecraft: review vulnerability assessments to suggest possible survivability enhancement solutions.
- c. Mission 4 Performance: examine Shuttle modifications proposed to achieve the desired performance of DoD's Mission 4.
- d. Launch Facilities, Procedures: review and compare plans for launch facilities and procedures for handling the Shuttle and payloads at Vandenberg Air Force Base (VAFB) and the NASA Kennedy Space Center (KSC).
- e. Payload Integration: review and critique plans for conducting analytical integration of payloads with the Shuttle.
- f. Environmental Satellites: compare military and civil plans for meteorological and oceanographic satellites to identify opportunities and difficulties in combining future programs.

The salient observations on each of the above topics from the study were the following:

- a. • A significant contributor (up to 40 percent according to USAF and NASA estimates) to the cost of launching experimental payloads in the sortie mode is the analytical verification of compatibility ("integration") of the experiment with the Shuttle; the integration cost may be reduced by the Air Force by their proposed "class cargo" generalized integration analysis that, once done in detail, may not have to be repeated in such costly detail.
- Choice of support structure for experiments will be made on the basis of compactness and light weight (for a given experimental weight) rather than on intrinsic cost, to minimize launch costs as computed by the NASA volume and weight formulas.
- The preparations for the first STP sortie flight are running on a much tighter schedule than the equivalent NASA preparations for the first Spacelab flight in the same time period. STP should be encouraged to continue to investigate ways to reduce the schedule disparity by making use of NASA experience and hardware.
- b. A Space Division-funded Rockwell study of survivability had not been released by the Air Force during FY 1979 to allow an IDA review for inclusion in this paper. No substantive effort was expended on this subtask this year.
- c. The performance of the Shuttle will initially be inadequate to accomplish the military Mission 4. When weight-reduction efforts have been completed, two propulsion developments will be necessary to give the desired performance: (1) modifying the main

engines for 109 percent thrust and (2) adding auxiliary boosters. A modified Mission 4, reduced in man-days on orbit rather than in payload, could be accomplished with either. NASA's plans for modifying the engines indicate qualification by the end of CY 1980; plans for liquid booster modules are on-going and they could be available before the first Mission 4 flight if required.

- d. Estimated required checkout times of military payloads exceed allowable pad occupancy times at KSC; modification of the Solid Motor Assembly Building, incorporating a facility for off-line payload-processing, appears to be the best solution.
- e. The cost of analytical integration procedures for an operational, autonomous satellite is estimated by the Air Force to be as much as 28 percent of the delivery cost. Cost savings are possible through reducing overlap in the overseeing organizations and reducing requirements for detail in analyses.
- f. Complete convergence of post-1985 military and civil environmental satellites appears to be feasible, with a potential IDA-estimated cost savings of from five to fifteen percent.

## EXECUTIVE SUMMARY

This study\* continues several earlier IDA studies and analyses examining DoD issues concerning the Space Shuttle program and use of the Space Shuttle vehicle. The objective of this study was to assist the DoD by identifying, and suggesting possible means of resolution of, issues in particular areas of interest specified by DoD regarding military use of the Shuttle. The specified areas of interest for FY 1979 are the following (paraphrased from the Task Order):

- a. Space Test Program (STP) experiments in the sortie mode: review and examine supporting hardware characteristics and scheduling constraints.
- b. Survivability of the Shuttle and other spacecraft: review vulnerability assessments to suggest possible survivability enhancement solutions.
- c. Mission 4 Performance: examine Shuttle modifications proposed to achieve the desired performance of DoD's Mission 4.
- d. Launch Facilities, Procedures: review and compare plans for launch facilities and procedures for handling the Shuttle and payloads at Vandenberg Air Force Base (VAFB) and the NASA Kennedy Space Center (KSC).
- e. Payload Integration: review and critique plans for conducting analytical integration of payloads with the Shuttle.

---

\* Performed for the Office of the Director (Offensive and Space Systems), OUSDR&E, involving twelve man-months of effort.

- f. Environmental Satellites: compare military and civil plans for meteorological and oceanographic satellites to identify opportunities and difficulties in combining future programs.

Because of the broad scope of these issues and the relatively small level of effort authorized, the studies were conducted as overviews of the DoD concerns without examining individual areas in detail. Reliance was made on available relevant systems studies, other reference information, and individual discussions with appropriate program personnel at the USAF Space Division, NASA Headquarters, Vandenberg Air Force Base, Kennedy Space Center, Marshall Space Flight Center, Johnson Space Center, Analytic Services Inc.(ANSER), Headquarters USAF, and NOAA. With the exception of the flight-rate analysis (p. 49) and cost estimates for the METSATs (p. 75), no independent IDA analyses were performed.

The salient observations on each of the subtask topics from this study are as follows:

#### A. SPACE TEST PROGRAM EXPERIMENTS

An illustration of the potential ultimate involvement of man in experiments in the sortie mode is shown in the cutaway illustration of the Shuttle and a Spacelab assembly in Fig. S-1. The Spacelab pressurized compartment, pallets (cradles) and experiments, and personnel engaged in a broad spectrum of activities are shown. Initial plans for the Air Force STP sortie experiments involve cradles only and two to four mission/payload specialists operating experiments from the aft flight deck.

The STP sortie experiments would use reusable, general-purpose Sortie Support Equipment (SSE) mounted in the orbiter rather than an expendable free-flying spacecraft bus to support experimental apparatus. According to the USAF, the accompanying reduction in integration and flight costs would be from an

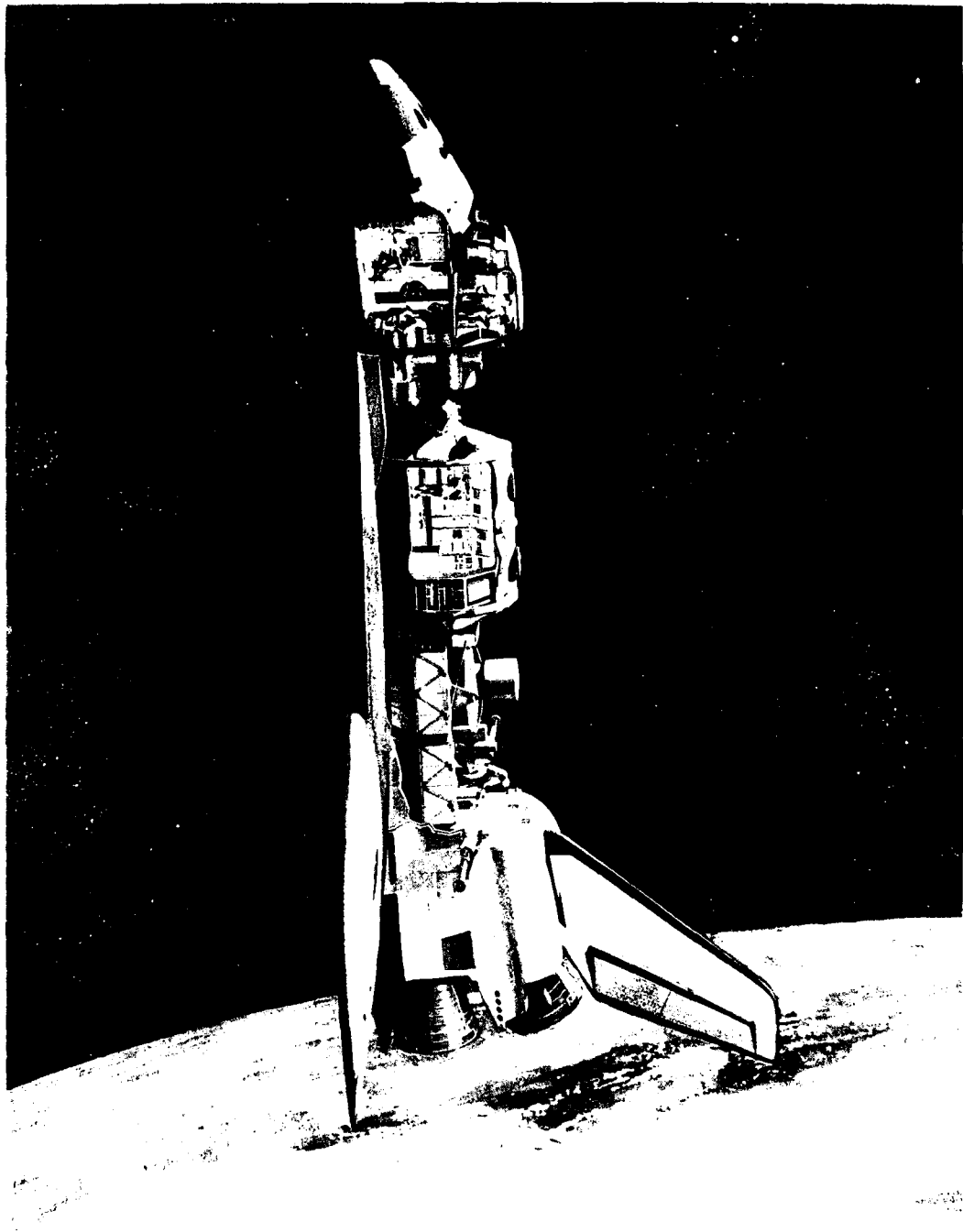

FIGURE S-1. Cutaway View of Shuttle with Spacelab Hardware.  
(Courtesy Rockwell International.)

estimated \$50M\* for a free-flyer to about \$15M\* for each of the two sortie flights expected to be required to give the same data yield as the free-flyer. The \$15M\* includes about \$60M\* for experiment integration (consistent with NASA estimated costs). This latter significant cost element *may be reduced by the Air Force by their proposed "class cargo" generalized integration analysis* that, once done in detail, may not have to be repeated in such costly detail.

Structural support of experiments in the cargo bay is envisioned to be supplied by a general-purpose cradle. Options include the GE Standard Test Rack, the Spacelab Pallet (and derivatives), and cradles designed for the Inertial Upper Stage, the Multimission Modular Spacecraft and the Spinning Solid Upper Stage. *Choice from these will most likely be made on the basis of least weight or volume to support a particular experiment array rather than on intrinsic cost*; all satisfy minimum criteria for structural adequacy.

The lead time for preparation for the first STP sortie flight planned at this time for late FY 1982 includes astronaut selection and training, and selection and acquisition of the principal support equipment: the cradle, the pointing system, and the controls and displays for manned interaction. Comparison of STP plans with NASA plans for the analogous NASA sortie mission, Spacelab-2 in Fall 1982, indicates that *STP is running on a much tighter schedule*; NASA has already chosen its payload specialist candidates and is constructing a training facility for introduction in early 1980, while STP has not done either of these. *STP should be encouraged to continue to investigate ways to reduce the schedule disparity by making use of NASA experience and available hardware* such as the NASA training facility, the Spacelab Pallet, and the Spacelab pointing system. STP plans to release an RFP early in 1980 to define their requirements for Sortie Support Equipment.

---

\* See page 22.

## B. SURVIVABILITY

The FY 1979 activity in analysis of survivability of the Space Transportation System has been confined to a Space Division-funded Rockwell study that was to be released by the Air Force later this fall. The conclusions were not available for IDA review, so no effort could be expended in this area in this paper. The Rockwell analysis considered system vulnerabilities in ground support, communications, and flight operations. Potential problem areas, consequences of the problems, and possible options for resolution were identified. A much larger follow-on study by TRW is planned.

## C. MISSION 4 PERFORMANCE

*The performance of the Shuttle initially will be inadequate to accomplish the military Mission 4. When on-going weight-reduction efforts are completed, two propulsion developments will be necessary to give the desired performance, (1) full power (109% thrust) operation of the main engines and (2) adding auxiliary booster modules, composed of a Titan Stage 1 liquid rocket engine and partial tanks, to the base of the External Tank. While either of these alone could allow accomplishment of a modified Mission 4, not reduced in delivered payload but reduced in man-days on orbit and recovery capability, both are required to accomplish the agreed-on mission. NASA has plans to complete the main engine qualification to 109 percent thrust by the end of CY 1980, barring unforeseen problems. Plans for the liquid booster modules (LBMs) are being firmed up and initial funding will be requested in FY 1981 so that the LBMs should be available before the first Mission 4 flight.*

## D. LAUNCH FACILITIES, PROCEDURES

The Shuttle Launch Sites at VAFB and KSC will utilize significantly different payload handling procedures. At VAFB,

payloads are to be assembled and checked out in Payload Preparation Rooms at the pad, while military payloads at KSC are to be delivered complete and largely checked out according to the Air Force "factory-to-pad" concept, with minimal final checkout at the pad. However, a polling of the principal military satellite program offices indicates that *estimated required final checkout times exceed pad occupancy times allowed in pad-turn-around timelines* consistent with desired flight rates. IDA calculations of flight rates from projected check-out time requirements indicate that the allowable check-out time with the currently planned work week for the desired KSC 40 flights/year would be only 99 hours, versus program office estimates of 92-350 hours. To accommodate these payloads without compromising the flight rate, *either an off-line payload-processing facility or an increase in work week is needed*. It is concluded in this paper that a modification of the Solid Motor Assembly Building, incorporating a facility for off-line payload assembly and checkout, should have significant advantages both in operations and costs (see p. 54).

#### E. PAYLOAD INTEGRATION

The analytical integration procedure to assure compatibility of payloads with the Shuttle and upper stages is a complex process involving as many as *four organizations, several years, and as much as 28 percent (AF-estimated) of the delivery cost of a typical payload*. Accurate estimates of payload integration costs will be available only when specific payloads are considered. IDA review of AF estimates (p. 57) indicate that *integration cost savings are possible* in reducing overlap of the overseeing organizations, in reducing requirements for detail in analyses of such areas as loads, vibration, thermal stress and contamination, and in identifying some optional services as included in the NASA standard launch price.

## F. ENVIRONMENTAL SATELLITES

*Complete convergence of military and civil environmental-satellite spacecraft, sensors, and orbits for a joint DoD/NOAA METSAT system for use in the 1985-and-beyond time period appears to be technically feasible.* An IDA preliminary estimate (p. 75) of development, procurement and operations costs indicates a potential savings of 5 to 15 percent for a ten-year program with a three-satellite system. Sensor and orbital requirements for oceanographic satellites (NOSS) are sufficiently different from polar-orbiting METSATS that it does not appear efficient to converge the NOSS mission into future DMSP Block 6/NOAA-85 METSATS. Further convergence with remote-sensing LANDSAT functions could lead to an excessively heavy spacecraft and could compromise DoD needs for special meteorological data. A proposed additional LIDAR wind sensor of questionable need would double total sensor weight and triple the power requirement.

## CONTENTS

Abstract	111
Executive Summary	vii
Abbreviations	xix
I. INTRODUCTION	1
II. SPACE TEST PROGRAM	5
III. SHUTTLE SURVIVABILITY	29
IV. MISSION 4 PERFORMANCE	33
V. LAUNCH FACILITIES AND PROCEDURES	41
VI. PAYLOAD INTEGRATION	57
VII. ENVIRONMENTAL SATELLITE CONVERGENCE	63
References	87

## FIGURES

S-1. Cutaway View of Shuttle Sortie Assembly with Spacelab Hardware	ix
1. Spacelab Mission 2	7
2. Standard Test Rack (STR) Configuration (FUV Experiment with Points)	10
3. Spacelab Pallet Configuration	10
4. Fractional Spacelab Pallets	11
5. Cradle Assembly--IUS Two-Stage General Configuration	12
6. Flight Support System Elements for MMS	13
7. STS PAM-D Configuration	14
8. MPSS Concept for Pallet-Type Structures (Technical Features, Basic Structure)	15
9. Annular Suspension Pointing System	17

10.	Aft Flight Deck	18
11.	Astronaut Training Equipment	19
12.	Payload Crew Training Complex	23
13.	Payload Specialist Training Complex (PSTC)	24
14.	Proposed STP Program Schedule	25
15.	Spacelab Payload Mission 2--Master Schedule	27
16.	Space Shuttle Capability Evolution	34
17.	Thrust Augmentation Strap-on Motor Options	37
18.	Air Force Satellite "Factory-to-Pad" Concept	44
19.	KSC Launch and Checkout Facility	45
20.	NASA Current Turnaround Assessment	46
21.	DoD Factory-to-Pad Assessment	46
22.	Flight Rates for Different On-Pad Payload Checkout Times and Orbiter Turnaround Times	49
23.	Vertical Processing Facility (VPF)	51
24.	Solid Motor Assembly Building (SMAB) Phase III	52
25.	Proposed SMAB Floor Plan	53
26.	STS Payload Integration--Typical Schedule	58
27.	Work Breakdown Structure	60
28.	STS Delivery Cost--Typical DoD Spacecraft	61
29.	Remote Sensing Spectral Similarities	67

#### TABLES

1.	Proposed STP Program Mission Breakdown (\$M 1978)	6
2.	Size of STP Cradle Candidates	16
3.	Training Requirements Summary (Hours)	21
4.	Performance Reference Mission 4 (Payload Capability, lb)	38
5.	Individual Program Assessments of Checkout Time Requirements	48
6.	SMAB Phase III Cost Summary (Then Year \$ Millions)	55
7.	STS Payload Integration Manpower Estimates: Typical Spacecraft with IUS - KSC Launch Four-Year Integration Schedule	59

8.	Characteristics of DMSP Block 5D, TIROS-N, and SEASAT Satellites	66
9.	Summary of METSAT Data Requirements	69
10.	Sensor Requirements for Post-1984	71
11.	Possible Sensor Complement for a Totally "Converged" DoD and NOAA METSAT	72
12.	NOSS Primary Outputs	82

## ABBREVIATIONS

ASPS	Annular Suspension Pointing System (Sperry)
ATE	Astronaut Training Equipment
AVHRR	Advanced Very High Resolution Radiometer
CSE	Common Support Equipment (now Sortie Support Equipment)
CDMS	Combined Data Management System
DMSF	Defense Meteorological Satellite Program
ET	External Tank
GARP	Global Atmospheric Research Program
GOES	Geostationary Operational Environmental Satellite
GSFC	Goddard Space Flight Center
IPS	Instrument Pointing System (Dornier)
IR	Infrared
IRSSS	Integrated Remote Sensing System Study
IUS	Inertial Upper Stage
IVE	Interface Verification Equipment
JSC	Johnson Space Center
KSC	Kennedy Space Center
LBM	Liquid Booster Module
LIDAR	Light Detection and Ranging
METSAT	Meteorological Satellite
MPSS	Modular Payload Support Structure
MSFC	Marshall Space Flight Center

NASA	National Aeronautics and Space Administration
NOAA	National Oceanographic and Atmospheric Administration
NOSS	National Oceanic Satellite System
OLS	Operational Linescan System
OMCF	Orbiter Maintenance and Checkout Facility
OTV	Orbit Transfer Vehicle
OV	Orbiter Vehicle
PCR	Payload Changeout Room
PGHM	Payload Ground Handling Mechanism
PIC	Payload Integrating Contractor
POOMSCB	Polar Orbiting Operational Meteorological Satellite Coordinating Board
PPR	Payload Preparation Room
RFP	Request for Proposal
RSS	Rotating Service Structure
SAB	Satellite Assembly Building
SAMTEC	Space and Missile Test and Evaluation Center
SD	Space Division, Air Force Systems Command
SMAB	Solid Motor Assembly Building
SMMR	Scanning Multifrequency Microwave Radiometer
SOSM	Strap-on Solid Rocket Motor
SRB	Solid Rocket Booster
SSE	Sortie Support Equipment
SSME	Space Shuttle Main Engine
STP	Space Test Program
STR	Standard Test Rack
STS	Space Transportation System
VAB	Vehicle Assembly Building
VAFB	Vandenberg Air Force Base
VPF	Vertical Processing Facility

## I. INTRODUCTION

This study continues the examination of issues regarding the use of the Space Transportation System by the DoD as reported in previous IDA studies (IDA, 1977 and IDA, 1978). New issues examined include (1) a brief review of the proposed use of the Space Shuttle as a manned laboratory in space for the conduct of Space Test Program (STP) Experiments and (2) examination of the opportunities and difficulties in combining the functions of weather and oceanographic satellites, including the possibility of common hardware usage by both military and civil users. Some previous issues have been reexamined in the light of progress made in their resolution; still others have been introduced because of continuing concerns about Shuttle performance and survivability. In particular, the following issues are those specified in the task order:

- a. Space Test Program (STP) Experiments. These experiments are planned to utilize the Shuttle in the sortie mode. For this program, review the status of requirements definition and integration. Examine the adequacy of the Standard Test Rack, Spacelab pallet, or other options for providing support to the sortie experiments. Examine factors influencing the recycle time for an experiment (from flight to reflight) and the lead time for integration that would impact the desired first flight date in FY 1982.
- b. Survivability. Conduct a review of the issues regarding survivability of the Space Shuttle and other spacecraft and steps being taken to resolve them.

Identify significant areas of vulnerability and suggest practical solutions for their reduction. This effort should include review of any DoD, Services and industry studies of vulnerability and proposals for enhancing survivability.

- c. Mission 4 Performance. Identify possible constraints on Shuttle payload-carrying performance for Mission 4. Examine proposed Shuttle modifications for improving performance.
- d. Launch Facilities, Procedures. Review facility plans and planned launch procedures for the Vandenberg Air Force Base (VAFB) Shuttle launch site and those of the NASA Kennedy Space Center (KSC) to identify possible commonalities and redundancies. Examine time-lines for checkout of payloads at KSC utilizing the USAF factory-to-pad concept in comparison with checkout procedures at VAFB requiring three Payload Preparation Rooms.
- e. Payload Integration. Briefly review plans for payload integration procedures from the different organizations (NASA, USAF, contractors) with regard to possible overlaps, redundancies, and excess conservatism to discover any potential areas of cost reduction.
- f. Environmental Satellites. Review commonalities and irrevocable differences, if any, in instruments and orbits between DMSP and TIROS, and between DMSP and the planned NOSS. Perform an independent review of the stated opportunities and difficulties in combining weather and oceanographic satellites.

Because of the broad scope of these issues and the relatively small level of effort authorized, the studies were conducted as overviews of the DoD concerns without examining individual areas in detail. Reliance was made on available relevant

systems studies, other reference information, and individual discussions with appropriate program personnel at the USAF Space Division, NASA Headquarters, Vandenburg Air Force Base, Kennedy Space Center, Marshall Space Flight Center, Johnson Space Center, Analytic Services Inc. (ANSER), Headquarters USAF and NOAA. With the exception of the flight-rate analysis (p.49) and cost estimates for the METSATs (p.75), no independent IDA analyses were performed.

## II. SPACE TEST PROGRAM

On a sortie mission the experimental equipment remains in the Shuttle cargo bay and is operated either by automatic control or by an astronaut (mission or payload specialist) during the time the Shuttle is in orbit. Significant progress has been made in orienting the STP program to utilize the Shuttle (Aerospace, 1978 and AF/RDSL, 1978).

Table 1 depicts a proposed program of seven STP flights showing the principal cost elements anticipated. Each flight contains from three to six experiments and is planned to accompany a primary DoD payload (such as a DMSP satellite, for example) utilizing whatever space and weight margins are available after the primary payload requirements are satisfied. In this way substantial reductions in program costs are achieved, as the launch costs are absorbed by the prime program. The cost elements in Table 1 are preliminary and undocumented estimations, but serve to illustrate the nature of the effort required to fly a sortie mission. The largest cost element is experiment integration. Experiment integration, as discussed in IDA, 1977 and later in this paper, is a complex analytical compatibility-verification activity involving several organizations and technical disciplines and may extend over a period of several years. The \$5-6M costs assigned to this element seem reasonable on the basis of previous and current experience. For example, NASA's Spacelab 2 program, which is a sortie mission consisting of an assembly of nine experiments mounted on several pallets on the Shuttle cargo bay (Fig. 1) in the manner envisioned for the STP program, anticipates payload integration costs of the same order as shown in Table 1.

TABLE 1. EARLY PROPOSED STP PROGRAM MISSION BREAKDOWN (\$M 1978)  
SOURCE: AF/RDSL, 1978

COST ELEMENTS	BMD-1	BDM-2	GOLD-1	GOLD-2	HIRISE-1	HIRISE-2	LASSII
STS INTEGRATION	2.0	2.0	2.0	2.0	2.0	2.0	2.0
SPECIAL REQUIREMENTS	1.0	1.0	1.0	1.0	1.0	1.0	1.0
SEVEN DAYS ON-ORBIT	2.0	2.0	2.0*	2.0	2.0	2.0	2.0
ASTRONAUT TRAINING	1.0	1.0	1.0	1.0	1.0	1.0	1.0
EXPERIMENT INTEGRATION	6.0	5.0	6.0	5.0	6.0	6.0	6.0
ON-ORBIT SUPPORT	1.0	1.0	1.0	1.0	1.0	1.0	1.0
CSE REFURBISHMENT	0.5	1.0	1.0	1.5	0.5	2.0	2.0
TOTAL	13.5	14.0	14.0	13.5	13.5	15.0	15.0

\*Probably will require 14 days on orbit at \$3M more.

For repeated flights, integration costs are expected to be only from 20 to 40 percent of the first-time cost. A "class cargo" analysis concept (AF/RDSL, 1978), if it meets expectations, would preclude the need for requalification tests, as repeated integration verification analyses for each flight qualification acceptance would be verified via analytical subtraction to the flight-envelope conditions. A cost-related benefit derived from this concept is the reduction in time required for analysis and testing. It is estimated (AF/RDSL, 1978) that the lead time required to prepare a STP flight could be shortened by at least a year after the "class cargo" analysis is available.

Another controversial cost element is astronaut training. In this case the term "astronaut" should be interpreted as a "mission or payload specialist" and could apply to as many as four crew members. For Spacelab 2 (Fig. 1), NASA is training

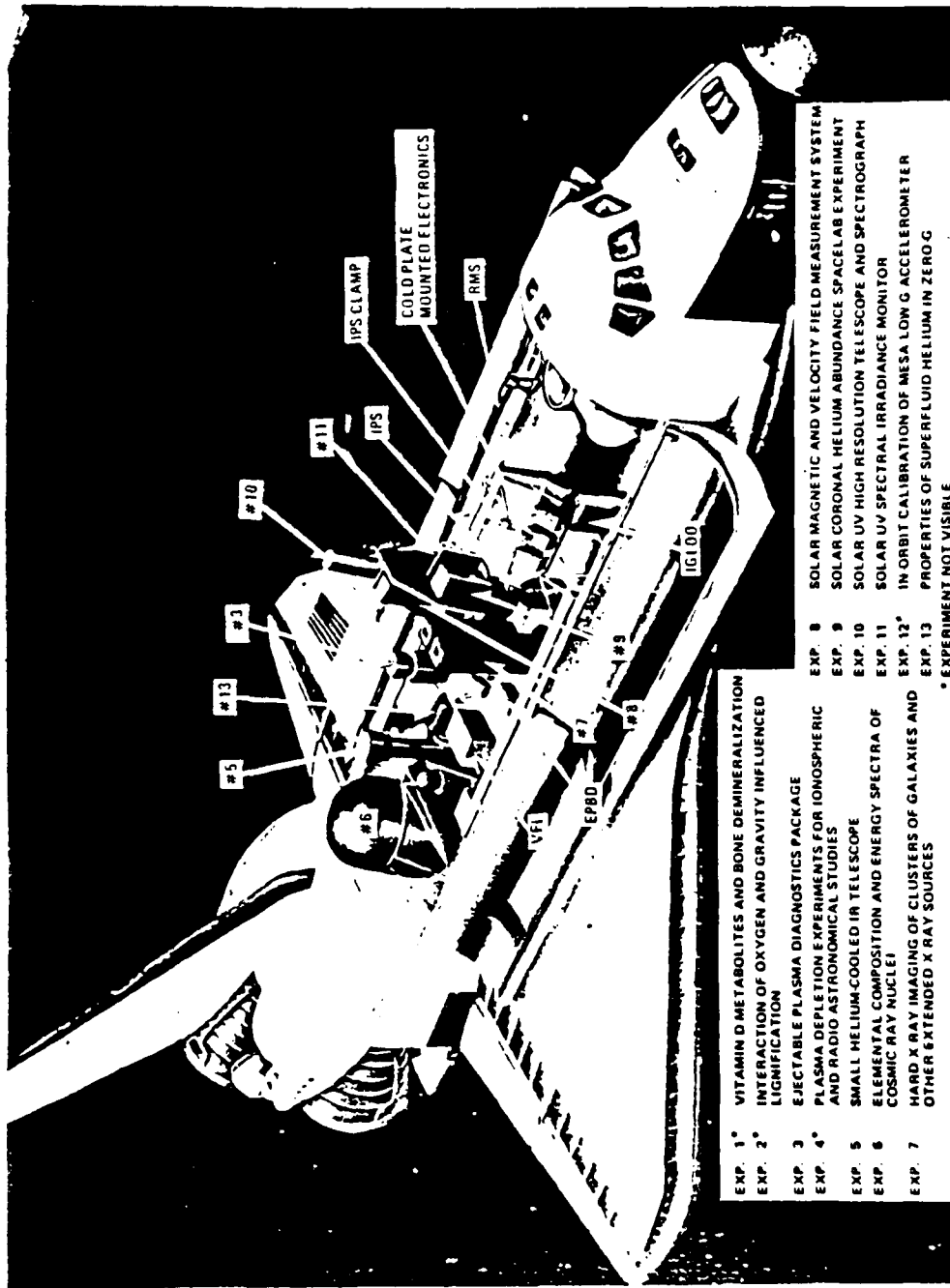

- EXP. 1\* VITAMIN D METABOLITES AND BONE DEMINERALIZATION
- EXP. 2\* INTERACTION OF OXYGEN AND GRAVITY INFLUENCED LIGNIFICATION
- EXP. 3 EJECTABLE PLASMA DIAGNOSTICS PACKAGE
- EXP. 4\* PLASMA DEPLETION EXPERIMENTS FOR IONOSPHERIC AND RADIO ASTRONOMICAL STUDIES
- EXP. 5 SMALL HELIUM-COOLED IR TELESCOPE
- EXP. 6 ELEMENTAL COMPOSITION AND ENERGY SPECTRA OF COSMIC RAY NUCLEI
- EXP. 7 HARD X-RAY IMAGING OF CLUSTERS OF GALAXIES AND OTHER EXTENDED X-RAY SOURCES
- EXP. 8 SOLAR MAGNETIC AND VELOCITY FIELD MEASUREMENT SYSTEM
- EXP. 9 SOLAR CORONAL HELIUM ABUNDANCE SPACELAB EXPERIMENT
- EXP. 10 SOLAR UV HIGH RESOLUTION TELESCOPE AND SPECTROGRAPH
- EXP. 11 SOLAR UV SPECTRAL IRRADIANCE MONITOR
- EXP. 12\* IN-ORBIT CALIBRATION OF MESA LOW G ACCELEROMETER
- EXP. 13 PROPERTIES OF SUPERFLUID HELIUM IN ZERO-G EXPERIMENT NOT VISIBLE

FIGURE 1. Spacelab Mission 2  
(Courtesy NASA)

two prime payload specialists and two backups, as well as two mission specialists. A review of the NASA training activity and schedule for Spacelab 2 reveals total training costs approaching those tabulated in Table 1.

The bottom cost element listed in Table 1 pertains to the refurbishment of the Common Support Equipment (CSE), now called Sortie Support Equipment (SSE), needed for all STP missions. Plans and ideas for the development of the necessary CSE to exploit the Shuttle for the manned sortie mode are discussed in detail in Aerospace, 1978, AF/RDSL, 1978 and also ANSER, 1979. A major milestone was achieved on June 1, 1979 with the issuance of a draft Request for Proposal (RFP) to interested contractors, DoD sponsors, and Experimenters (SD, 1979).

The draft Request for Proposal is comprehensive and describes in detail the hardware and software requirements for the sortie mode of Shuttle operations for the STP Program. The general performance characteristics for the Sortie Support Equipment are summarized there as follows:

The SSE shall perform the functions required for support of experiments by providing mounting structures and attachments, electrical power, communications and data handling, orientation and pointing control, thermal control, manned operations control, and software. The SSE shall perform these functions in conjunction with the Orbiter, astronauts, and ground facilities.

A challenge to potential contractors is to identify and adapt various types of hardware currently under development (e.g., components of Spacelab) rather than to undertake new developments. This utilization of hardware available from funded programs could require the allowance of hardware not constructed in compliance with military specifications. The draft RFP, in its cover letter, anticipates this possibility of reduced cost through relaxed specifications to allow use of "off-the-shelf" hardware. The information generated by this

step in SSE planning is to be used in the preparation of a hardware RFP to be released early in 1980.

Comparative analyses of different candidates for the STP cradle were made (GE, 1978 and TRW, 1978) for the STP office in FY 1978. In addition, British Aerospace has conducted a study of possible production of shortened versions of the Spacelab pallet, and briefed the results extensively in the U.S. in November 1978 (BAC, 1978). Candidates considered (not all by any one study) were the following:

1. GE Standard Test Rack (Fig. 2)
2. Spacelab Pallet (Figs. 3 and 4)
  - a. Half Pallet
  - b. Quarter Pallet
  - c. Pallet Frame
3. Inertial Upper Stage Cradle (Fig. 5)
4. Multimission Modular Spacecraft Cradle (Fig. 6).

Other candidates identified during the IDA study are the PAM-D (Spinning Solid Upper Stage - Delta) cradle (Fig. 7) and the Messerschmitt-Bölkow-Blohm Modular Payload Support Structure (MPSS) (Fig. 8) which would be available in one, two, or three segments.

The IUS Cradle and the MMS Cradle were eliminated early in the comparative analyses for STP because they were large, heavy, and too specific in design; they would require extensive modifications to allow them to act as general-purpose STP cradles. The Pallet derivatives were not considered in the comparative analyses because they had not yet been proposed (which they eventually were by British Aerospace). The principal conclusion of the comparative analyses of the Standard Test Rack (STR) and Spacelab Pallet was that a selection by cost would depend more on the weight and volume of experiments to be carried and the weight and length capacity of the cargo bay not used by the primary payload than on the intrinsic development or production

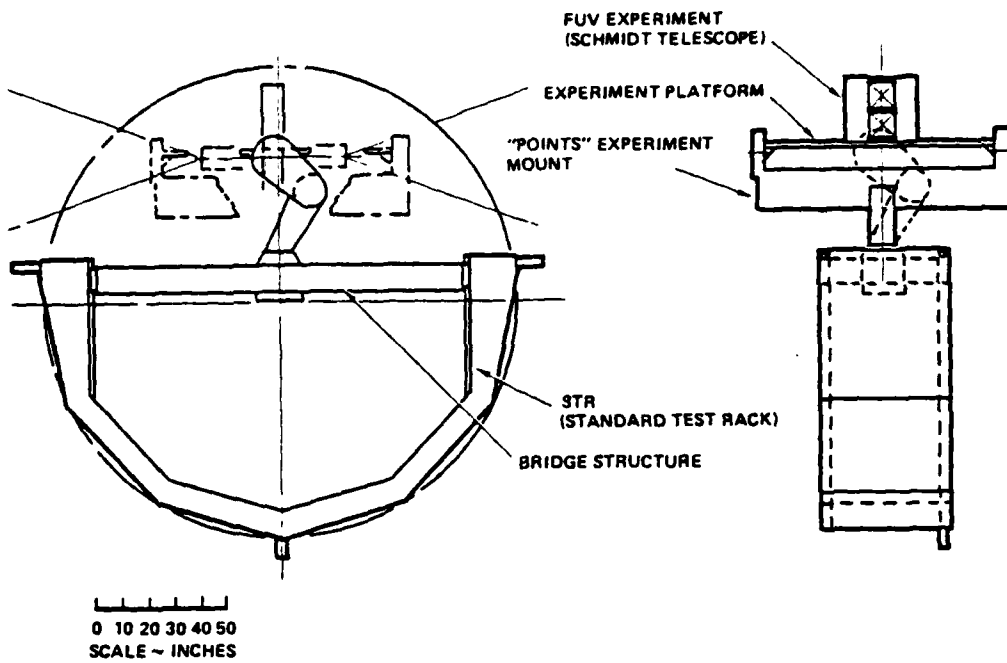

FIGURE 2. Standard Test Rack (STR) Configuration (FUV Experiment with "Points"). Source: GE, 1978

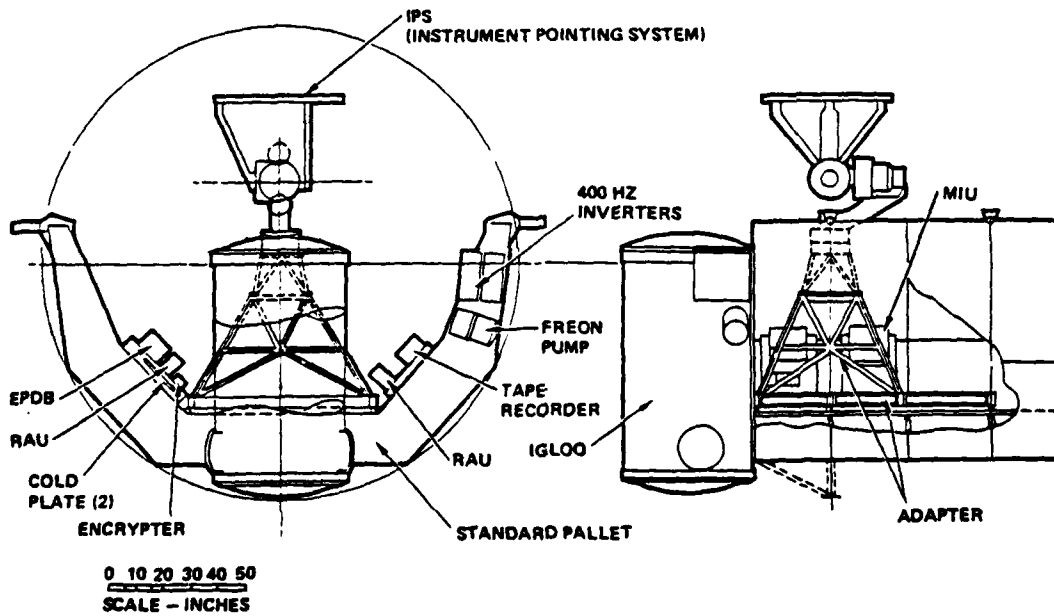

FIGURE 3. Spacelab Pallet Configuration Source: TRW, 1978

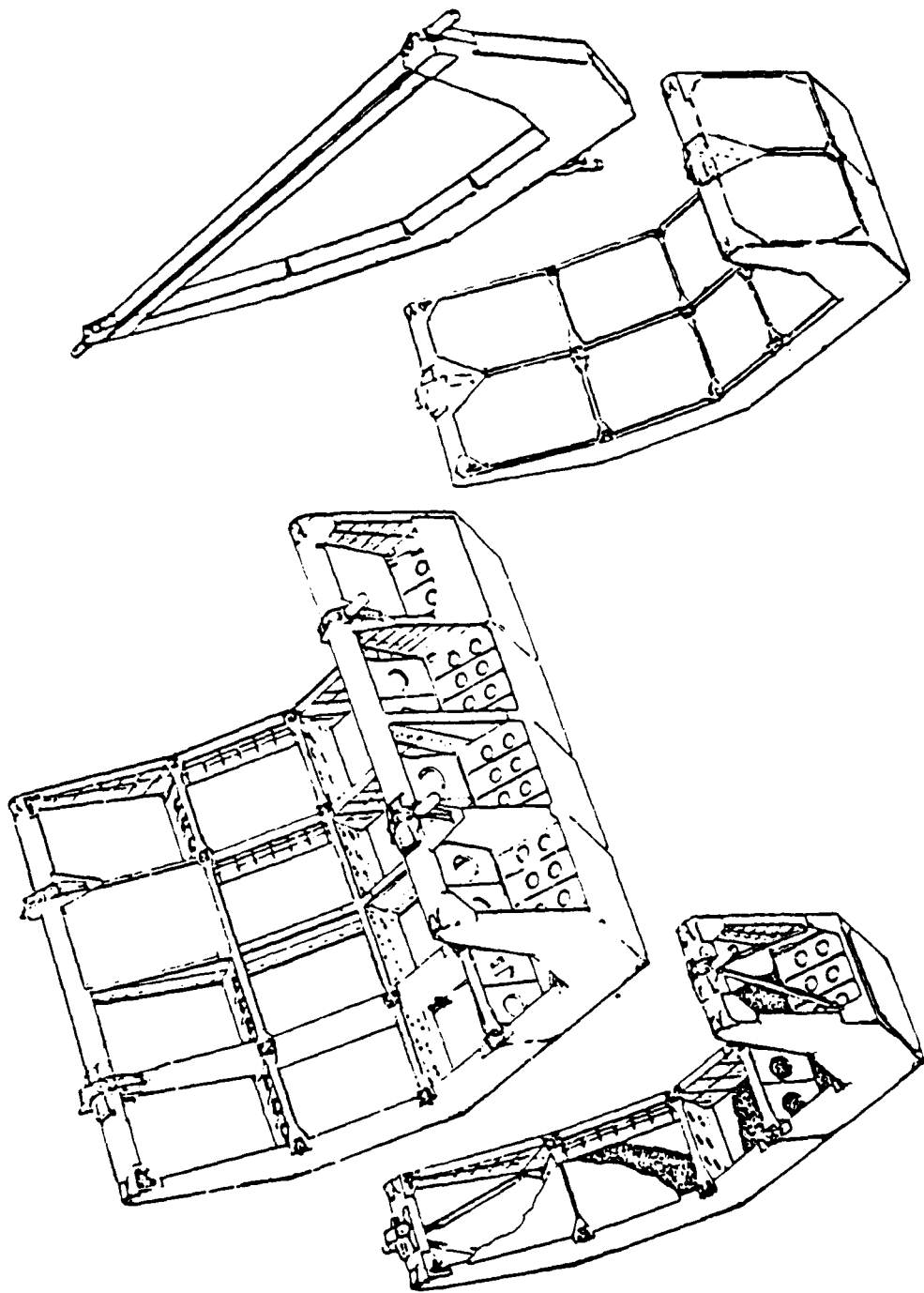
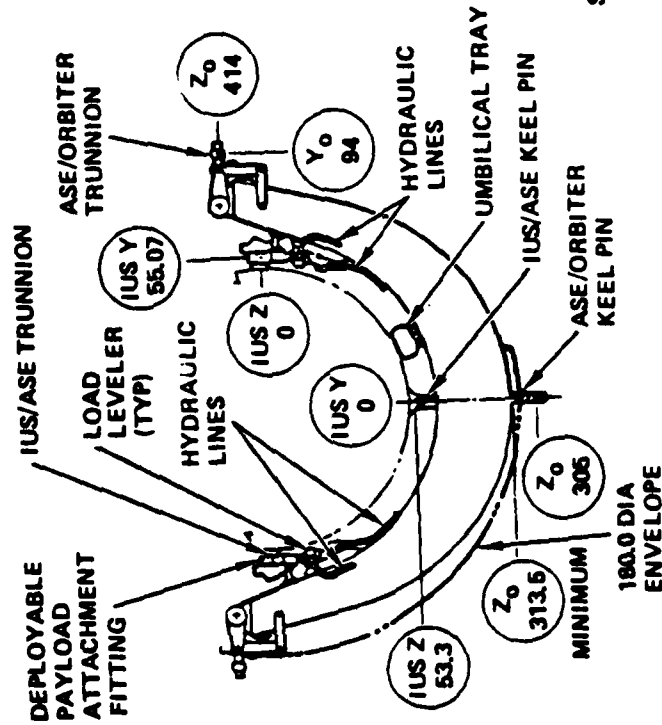
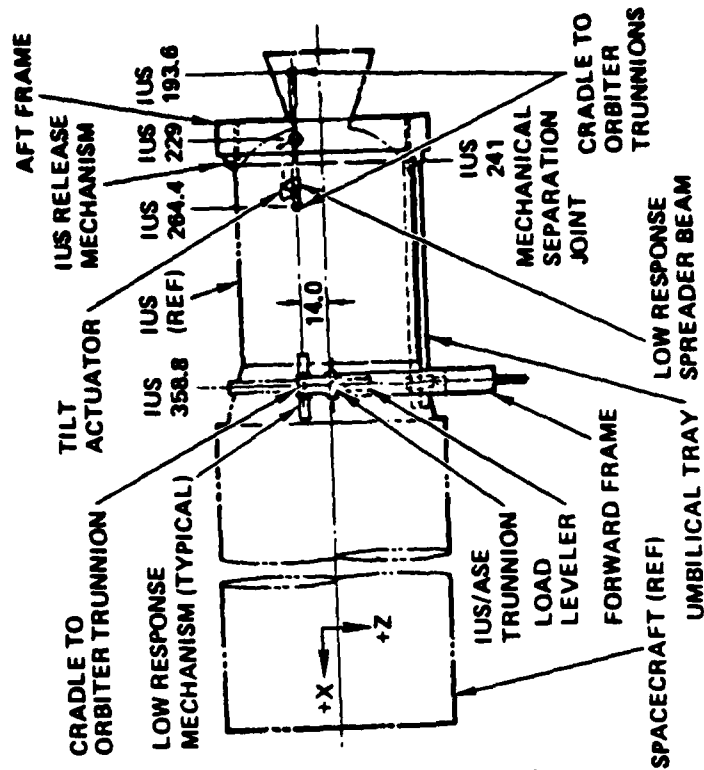

FIGURE 4. Fractional Spacelab Pallets  
Source: BAC, 1978



FORWARD FRAME

FIGURE 5. Cradle Assembly - IUS Two-Stage General Configuration  
Source: TRW, 1978

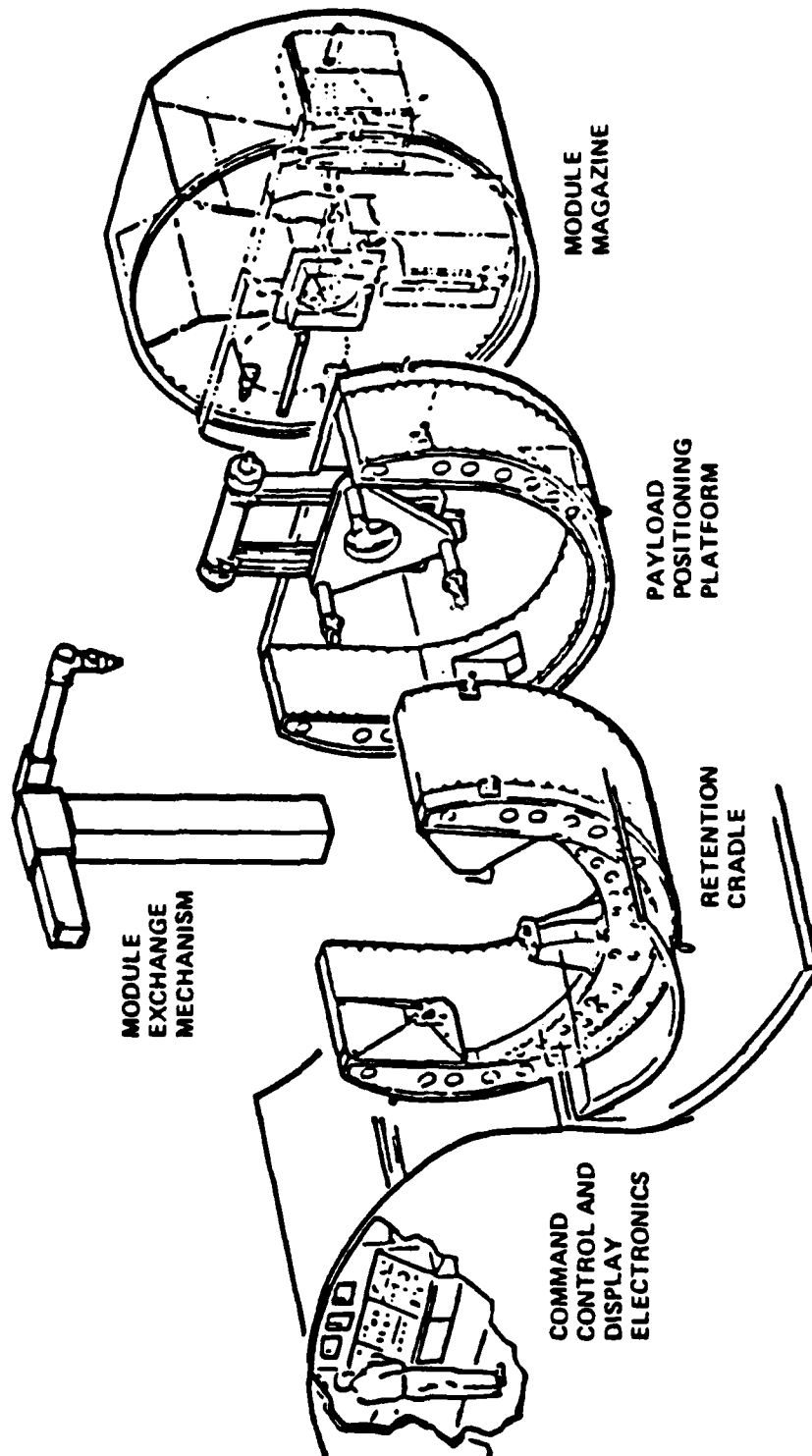

FIGURE 6. Flight Support System Elements for MMS  
 Source: TRW, 1978

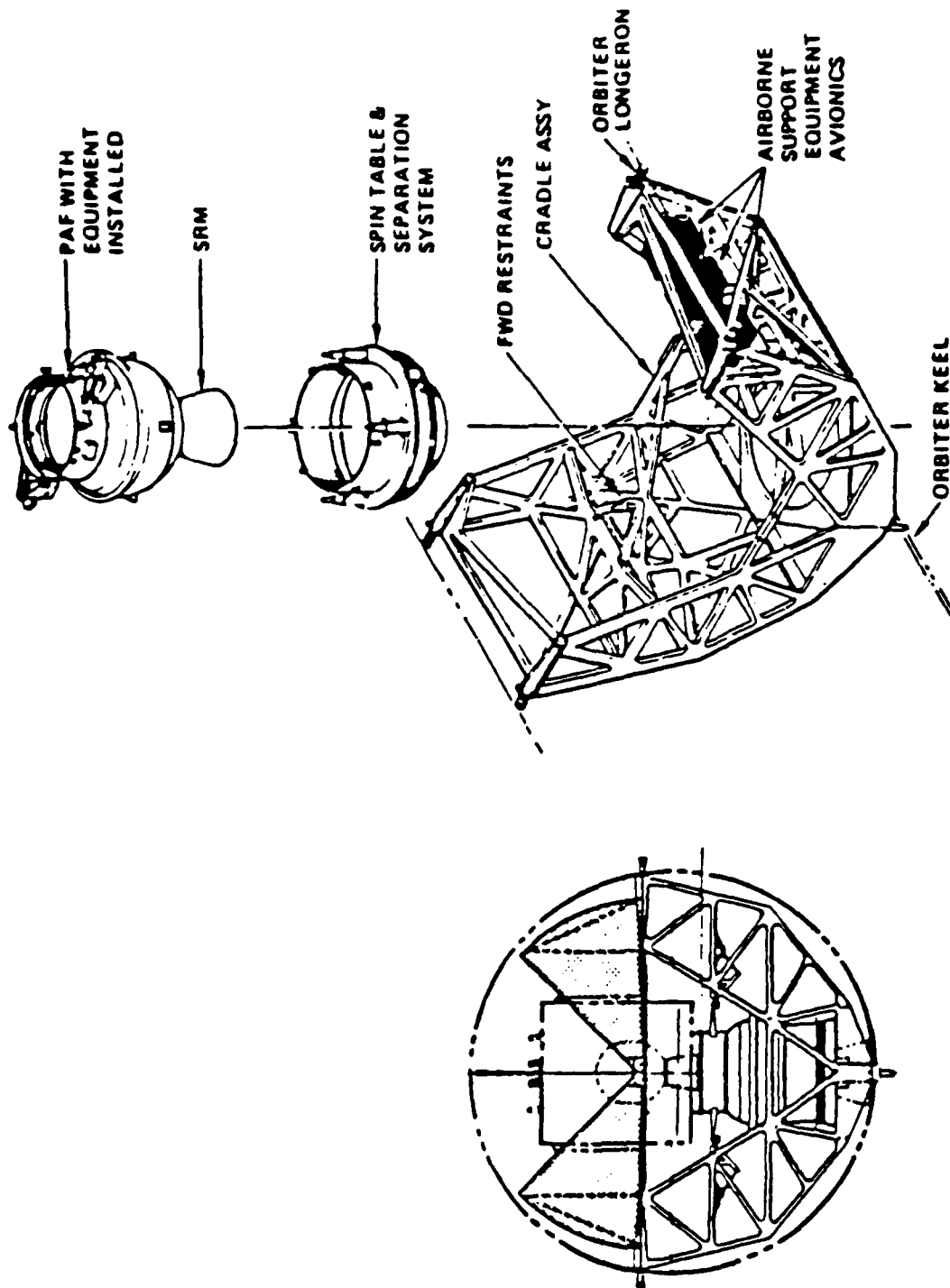

FIGURE 7. STS PAM-D Configuration  
(Courtesy McDonnell-Douglas Astronautics Co.)

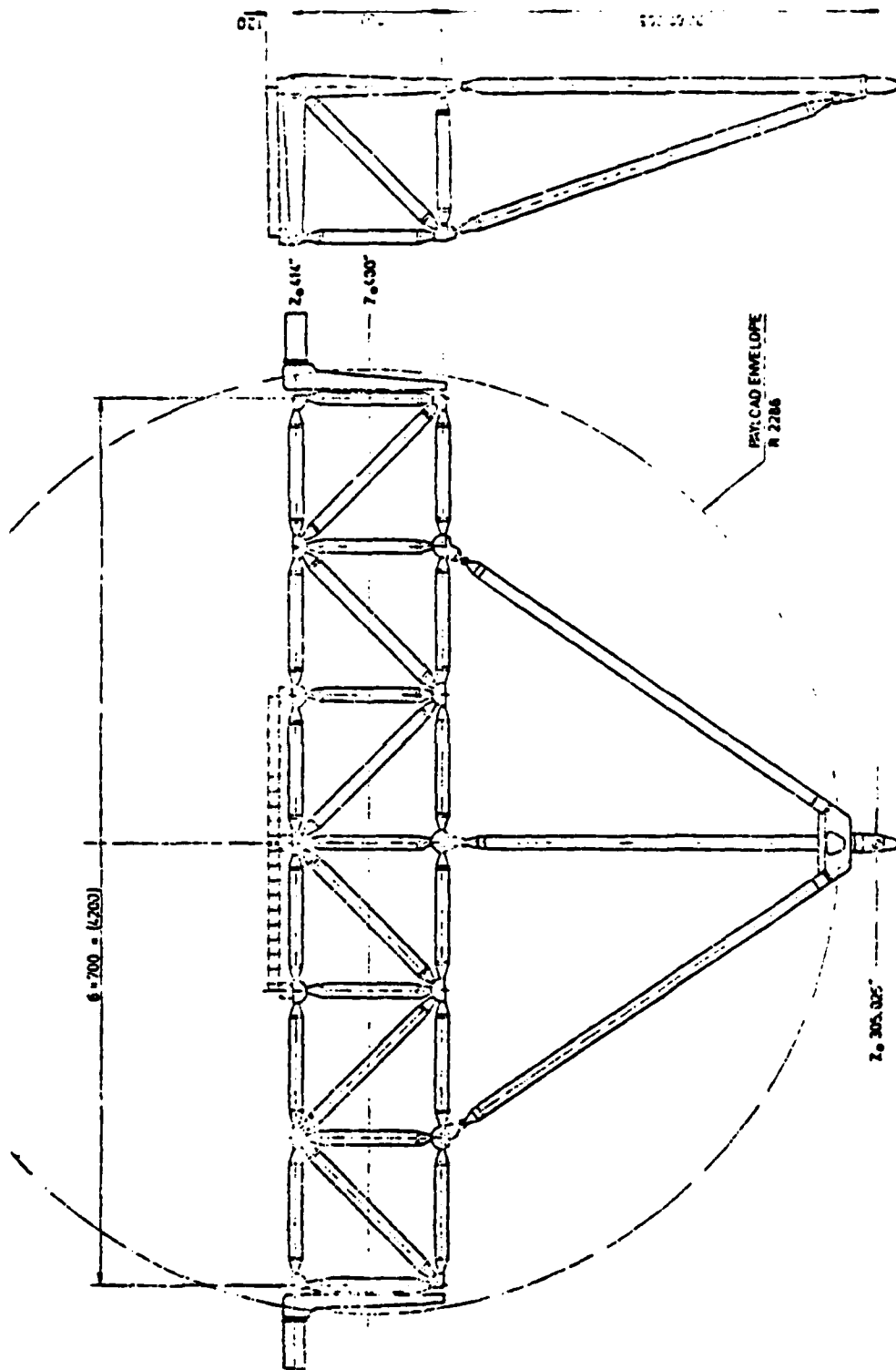

FIGURE 8. MPSS Concept for Pallet-Type Structures  
 (Technical Features, Basic Structure)  
 Source: MBB, 1979

cost of the cradle. The question was not of adequacy of a candidate but of suitability or adaptability to different experimental apparatus. The relative size of some of the cradle candidates is given in Table 2.

TABLE 2. SIZE OF STP CRADLE CANDIDATES

	<u>Length, ft</u>	<u>Weight, lb</u>	<u>Load Capacity, lb</u>
Standard Test Rack	4	4000	8000
Spacelab Pallet	10	4000	6600 (w/igloo)
Igloo	3.6 dia x 8h	1400	----
Pallet Frame	0.5	400	1800
IUS Cradle	12.2	8000	32,000
PAM-D Cradle	7	2300	6600
MPSS (1-3 segments)	2.6-7.2	400-770	3600-5840

The principal and most complex subcomponent to be furnished with the cradle by STP for general experimenters is a pointing system. Two versions are under consideration: the Dornier Instrument Pointing System (IPS), from the Spacelab Pallet (Fig. 3), and a Sperry Annular Suspension Pointing System (ASPS), shown in Fig. 9, planned by NASA as an advanced technology backup to the IPS.

The other major hardware category required to support STP sortie experiments in the Shuttle are the controls and displays in the Orbiter aft flight deck for manned interaction with the experiments. Figure 10 shows an example layout of such controls and displays (ANSER, 1979).

Considerable emphasis is being given to training requirements for the Space Test Program. Requirements are defined in the draft RFP (SD, 1979) for sortie support astronaut training that consists of three major elements--Astronaut Training Equipment (ATE), a training facility, and the astronaut and

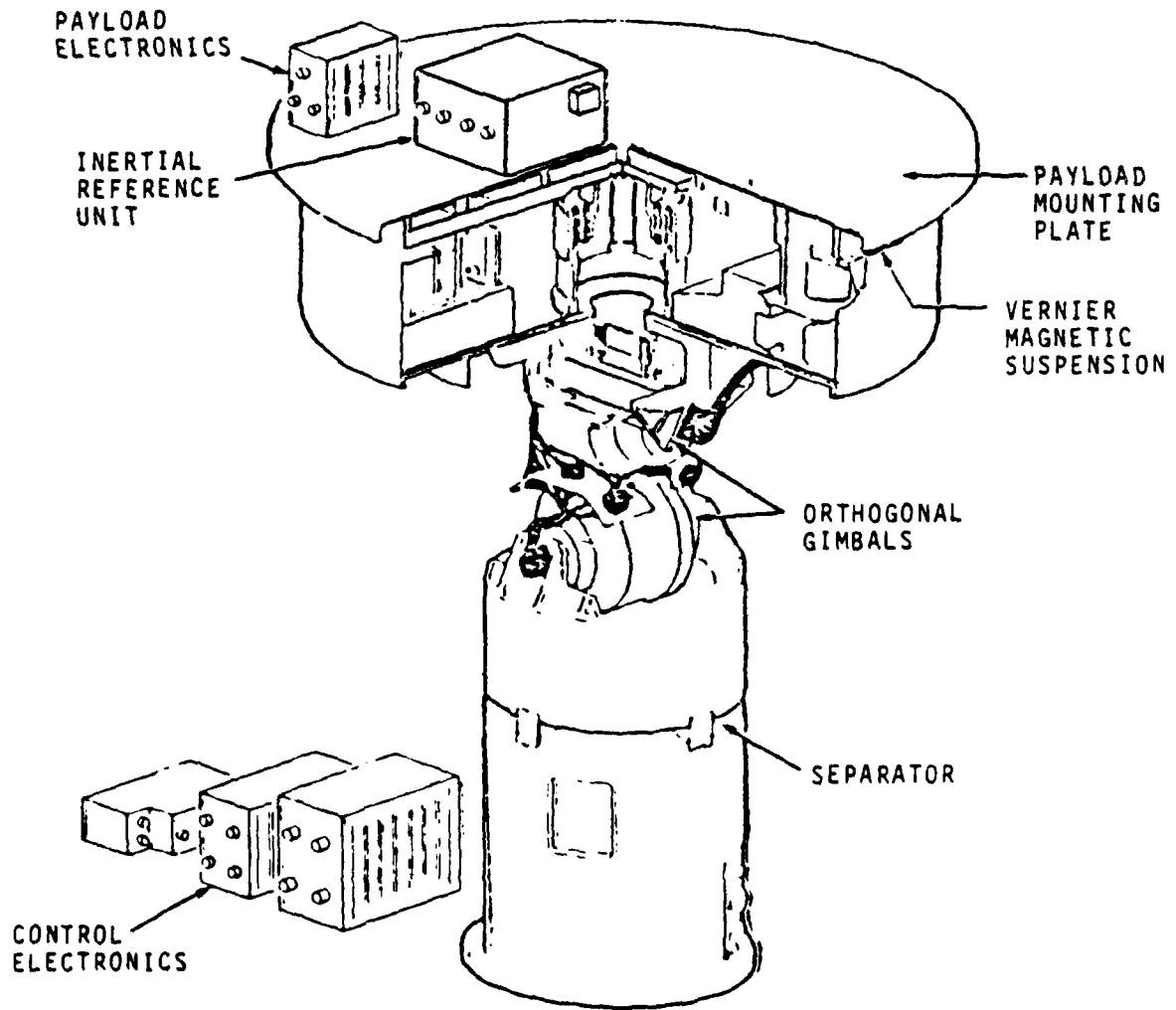

FIGURE 9. Annular Suspension Pointing System  
 Source: ANSER, 1979

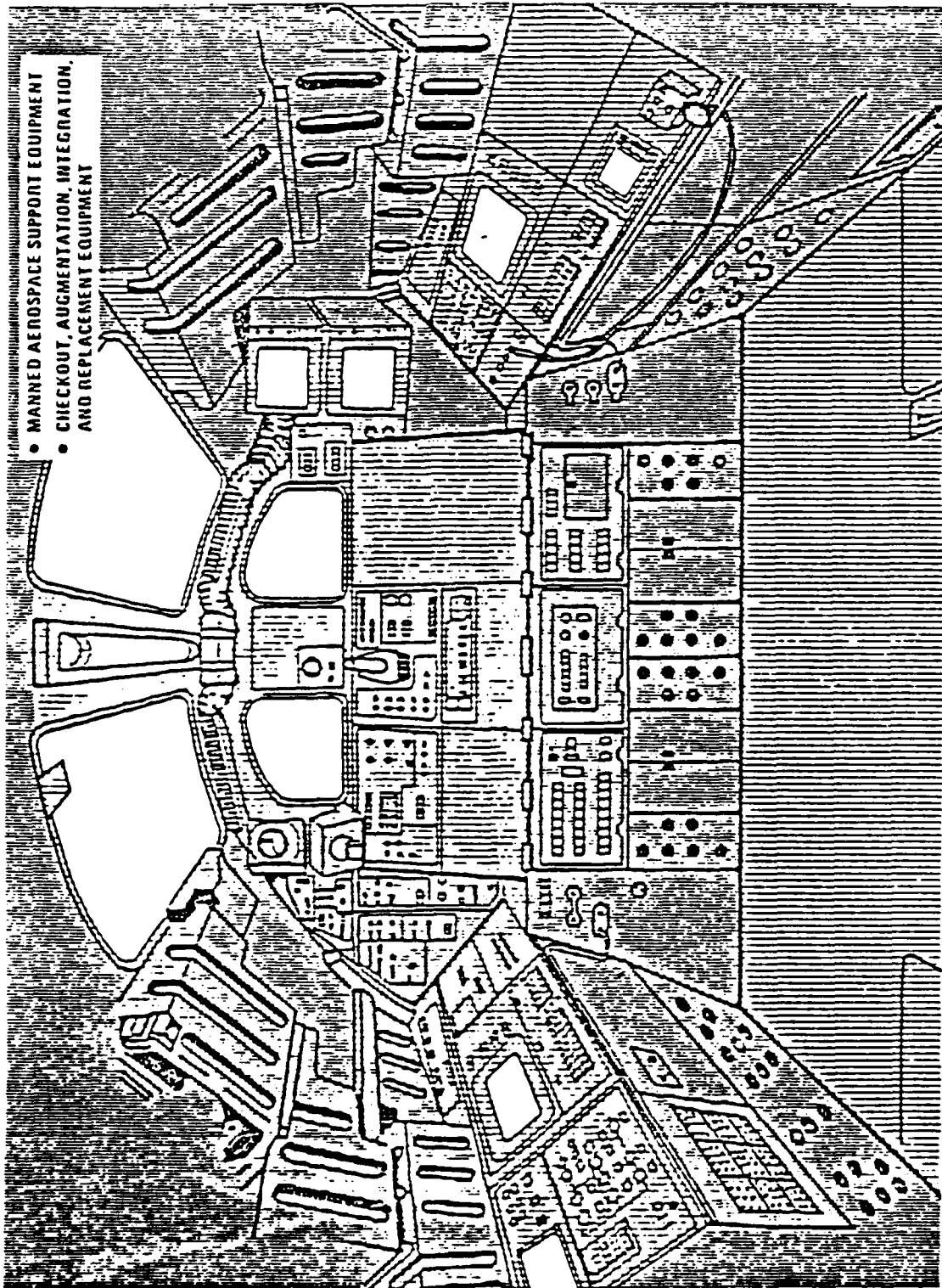

FIGURE 10. Aft Flight Deck  
Source: ANSER, 1979

support personnel training program. The ATE provides the environments required to train astronauts and ground support personnel in the skills and procedures necessary to conduct various sortie flights. It includes an aft flight deck mockup (Fig. 11), the hardware/software required to simulate the cargo bay and the aft flight deck equipment, and a training computer system to execute software. The ATE must also be capable of interfacing with mission-unique experiment hardware/software provided by the experimenters or mission-integration contractor.

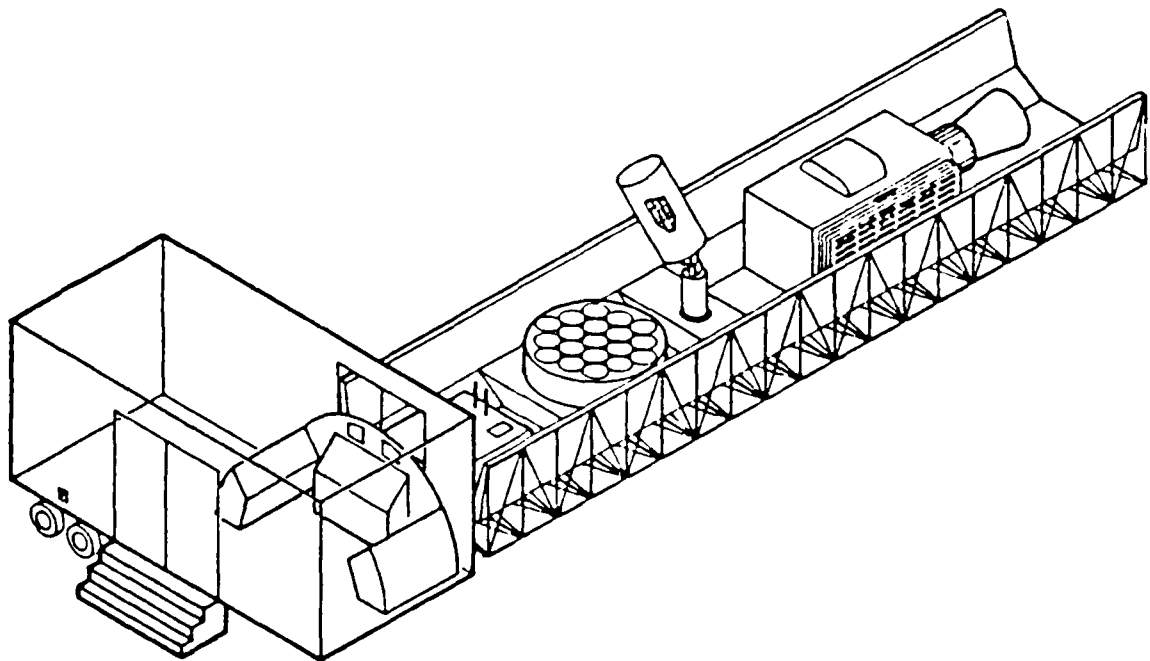

FIGURE 11. Astronaut Training Equipment  
Source: ANSER, 1979

The stated objective of the astronaut training program is to provide adequate training at minimum cost. Simulator costs depend on the fidelity required. Contractors are to evaluate

each item in the training plan for costs-versus-benefit considerations and to use simple designs, low-cost materials, non-dedicated computers, and existing software. It will be difficult to specify the required simulation program for the astronaut/experiment interface until a detailed description of the nature of crew participation is available.

A Spacelab crew training program is currently underway at NASA's Marshall Space Flight Center (MSFC). Many features of this program are relevant to the STP training program. Two key issues of the Spacelab flights are important considerations for the Space Test Program as well, i.e., crew composition and the training aids required. The central concern regarding crew composition is whether a payload specialist is really required. If the tasks the payload specialist is to perform are indeed "unique", i.e., requiring knowledge or techniques unique to his field of specialization, then his presence aboard the Shuttle may be justified. On the other hand, if demands on his time are modest and require the performance of relatively routine tasks such as manipulating switches or monitoring instruments, then it has been suggested that the mission specialist, who is a regular member of the crew (and provided for in the Standard Flight Cost) could perform these functions and save the time and expense of training and flying a payload specialist. NASA currently has under review a revision to its document prescribing requirements for Spacelab crew selection that would make mandatory a determination of the "uniqueness" requirement for a payload specialist by the user. A parallel situation exists regarding the selection of mission specialists or payload specialists for the Space Test Program. Monitoring of NASA's crew selection and training program on the Spacelab project by the DoD should be fruitful in this regard.

Four payload specialists have been selected and are currently in training for NASA's Spacelab 2 Mission (Fig. 1).

A summary of the projected training time requirements for each specialist is contained in Table 3. Shown are the estimated hours required in the various training activities and the locations at which they occur. The activities cover the entire training spectrum from individual instrument familiarization at the site of the instrument contractor to integrated mission simulation at the launch site (KSC) and the mission control center (JSC). The mission training simulator is located at the Marshall Space Flight Center (MSFC).

TABLE 3. TRAINING REQUIREMENTS SUMMARY (HOURS)  
(Courtesy NASA)

	INSTRUMENTATION DEVELOPMENT SITE	BRIEFING AREA	LAUNCH SITE	MSFC TRAINING SIMULATOR	STS SITE	TOTALS
STS SYSTEMS	---	---	8	---	198	206
INDIVIDUAL EXP.	779	---	352	---	---	1131
EXPERIMENTS/COMS	---	---	---	288	---	288
ORIENTATIONS	---	40	16	---	---	56
MISSION PLANNING	---	144	---	---	---	144
INTEGRATED PAYLOAD OPNS	---	---	248	112	---	360
INTEGRATED MISSION SIMULATIONS	---	---	---	---	48	48
TOTAL	779	184	624	400	246	2233

Table 3 indicates that about 18 percent of the training hours will occur in the MSFC facility for the Spacelab 2 missions. Training in this facility is especially valuable during the six months prior to flight, when access to the actual integrated Spacelab equipment will be limited. The MSFC training

simulator (Figs. 12 and 13) is being designed and built on a \$650,000 budget, to be on line early in CY 1980. The key features of the Payload Specialist Training Simulator are the following: (1) exact mockups of crew controls and displays in the Spacelab module and the aft flight deck, (2) a computer-system replication of the Command Data Management System (Orbiter data bus), and (3) software models of the experiment (sensor) interaction with (data inputs to) the DMS data bus and with the experiment control and display panels. This simulator could be made available to any user (such as STP), or could be copied for a cost less than the original \$650K design and development cost. The software models of specific STP sensor outputs and control responses could be constructed in consultation with MSFC.

It has been argued (AF/RDSL, 1978) that STP testing via the sortie-mode operation offers considerable savings in integration and flight costs over tests using free-flying satellites. On the average, free-flyer satellites are estimated (op.cit.) to cost \$50M. If sortie-flight costs are of the order of the \$15M detailed in Table 1, and if two sortie flights are required to provide the same data as a free-flyer (op.cit), equivalent sortie costs are about \$30M, plus a prorated fee for the Common Support Equipment (CSE) required for the sortie flights. It was estimated (op.cit.) that the cost of the CSE would be paid for in eight sortie flights. Thereafter, at a rate of two sortie flights per year, estimated savings (op.cit) over equivalent free-flying satellite missions would range from \$10M to \$30M annually, depending on the cost of the equivalent free-flyer satellite.

The proposed STP program schedule (ANSER, 1979) is shown in Fig. 14. Shown are the anticipated dates for delivery of the various items of the Common Support Equipment required to support the missions. The flight dates of interest are

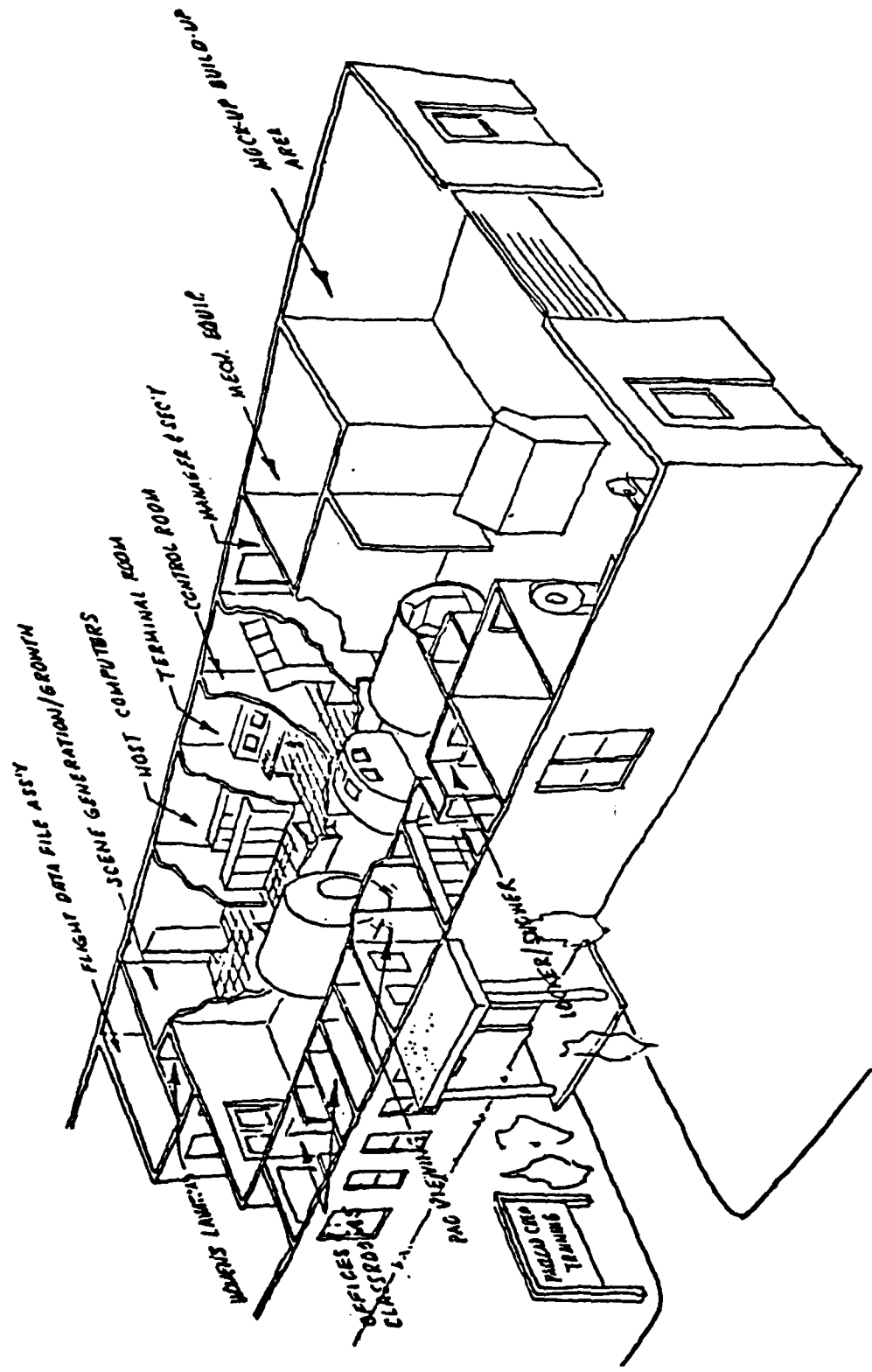

FIGURE 12. Payload Crew Training Complex  
(Courtesy MSFC)

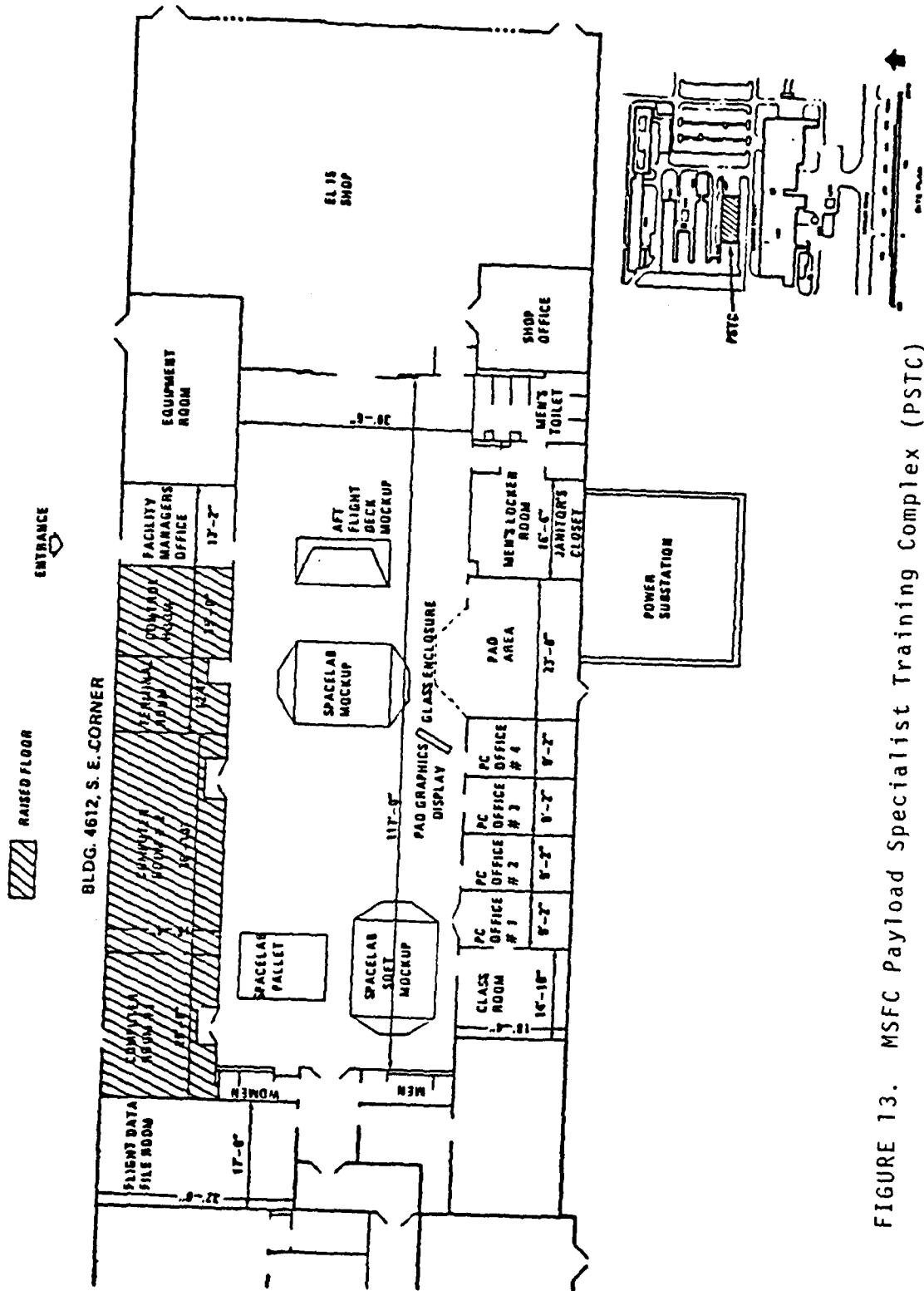

FIGURE 13. MSFC Payload Specialist Training Complex (PSTC)

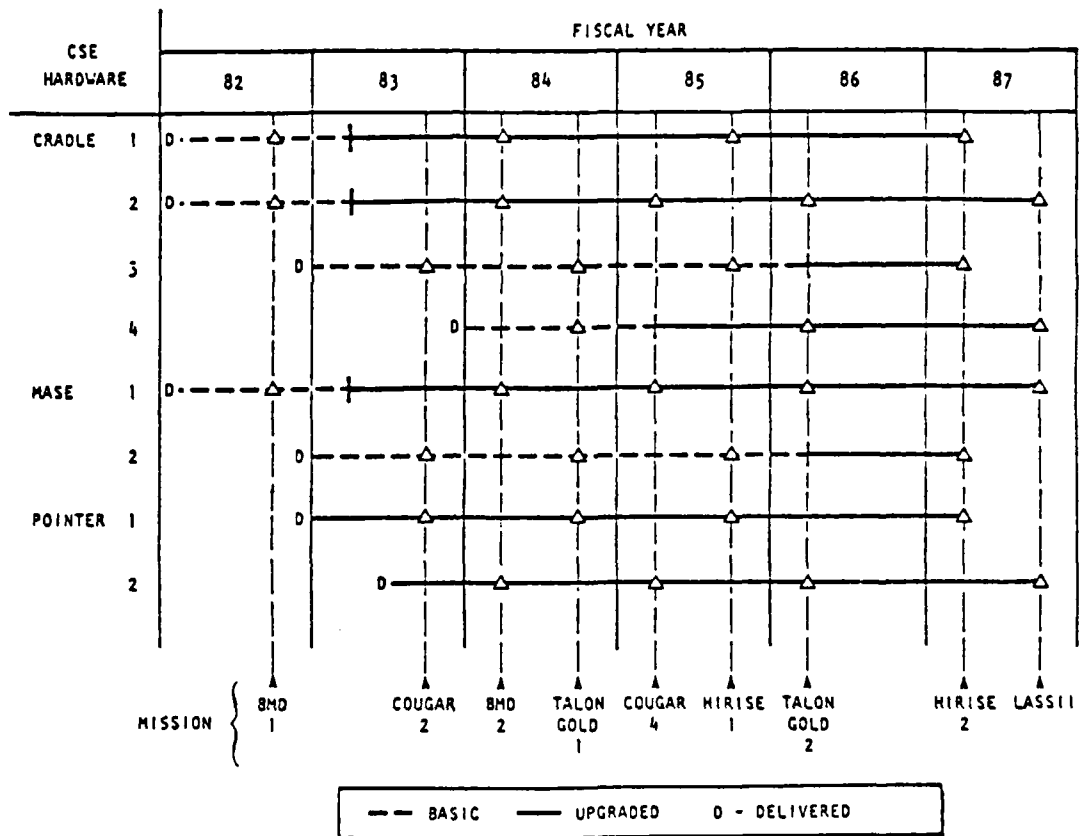

FIGURE 14. Proposed STP Program Schedule  
Source: ANSER, 1979

indicated on the bottom of the figure. In attempting to evaluate the timeliness of this schedule, reference is made to the master schedule of NASA's Spacelab Mission 2 shown in Fig. 15. The design and development phase of the experimental hardware for Spacelab Mission 2 begins approximately four years prior to the anticipated flight date, July 1982. Also, the payload specialists have already been selected--five years prior to the flight date--and their training has already begun. In view of this advanced preparation for Spacelab, the STP schedule seems optimistic regarding the time required to develop the payload and select and train the payload specialists for a first STP sortie flight planned (at the date of this writing) for the fourth quarter of FY 1982. The Space Division has initiated discussions with the Marshall Space Flight Center and should continue to review the Spacelab Mission 2 planning in order to identify unrealistically short preparation times in the lead-time schedule of the first STP sortie flight.

In summary, plans for utilizing the Space Shuttle in the sortie mode for STP experiments seem to be proceeding adequately, including the procurement of appropriate mounting hardware, but leadtimes for payload specialist selection and training seem too short. An RFP for the acquisition of sortie support equipment is expected to be released early in 1980.



### III. SHUTTLE SURVIVABILITY

Because of the importance of the survivability issue, it continues to receive study by the DoD and others. During the past year, an analysis was undertaken for the Space Division by Rockwell International and included an examination of three principal categories of targets of attack: (1) Ground Support, (2) Communications Links, and (3) Flight Operations. The tables following were reproduced from Space Division briefing materials. The three tables outline some preliminary sample results of the Rockwell study pertaining to threats against ground support in manufacturing, transportation, and launch facilities. This completed study is currently under review by Headquarters, USAF. The report was not available at the cutoff date of this paper: November, 1979. The Space Division is planning to award TRW a three-year contract for in-depth study of the full spectrum of shuttle survivability.



## Manufacturing

<u>STS ELEMENT</u>	<u>PRODUCTION</u>	<u>THREAT</u>	<u>DEFENSE</u>
<b>SHUTTLE</b>			
ORBITER	} SINGLE SOURCE LIMITED PRODUCTION	} ACCIDENT/ DISASTER/ SABOTAGE/ TERRORISTS	} FENCED PERIMETER  } GUARD CONTROLLED ENTRIES  } EMPLOYEE BADGING
OMS PODS			
SSME			
ET	} SINGLE/LIMITED SOURCE CONTINUING PRODUCTION		
SRB			
<b>IUS</b>			
STAGE			
SRMS			
<b>CONSUMABLES</b>			
12 MAJOR SUPPLIES			



## Transportation

<u>STS ELEMENT</u>	<u>CONVEYANCE</u>	<u>THREAT</u>	<u>DEFENSE</u>
<b>SHUTTLE</b>			
ORBITER	- CARRIER AIRCRAFT/ GROUND TRANSPORTER	} ACCIDENT/ DISASTER/ SABOTAGE/ TERRORISTS	} PATROLLED LANDING SITES & GROUND CONVOYS
ET	- LONG HAUL BY BARGE/ GROUND TRANSPORTER		
SRB	- SPECIAL RAILCAR/ GROUND TRANSPORTER		} LOW PROFILE DELIVERIES
SSME	- CRADLED ON DOLLY ON FLAT BED TRUCK		
<b>CONSUMABLES</b>			
LH <sub>2</sub>	} LABELED CRYOGENIC TANK TRUCKS	} ANNUAL CERTIFICATION	} LOW PROFILE DELIVERIES
LO <sub>2</sub>			
LN <sub>2</sub>			



## Launch Facilities

### PROBLEMS

- KSC — SINGLE STRUCTURE VAB CARRYING MANY OPERATIONS
  - SITE EXPOSURE — OPEN HOST BASE
- VAFB — SINGLE LAUNCH PAD WITH ON-PAD ASSEMBLY
  - SINGLE ORBITER PROCESSING BAY
  - SITE EXPOSURE — MILITARY WITH LEASED FARM LAND
  - EXPOSED TOW ROUTES — ORBITER 17 MILES; ET 5 MILES
  - SINGLE POINT ENTRY BY PHONE & POWER SERVICES

#### IV. MISSION 4 PERFORMANCE

Mission 4 is a payload delivery and retrieval mission of a modular spacecraft plus cradle weighing 32,000 lb at liftoff. The mission will deploy a spacecraft weighing 29,500 lb in a 150-nmi circular orbit at 98 deg inclination within two orbits after lift-off. A passively cooperative, stabilized spacecraft, weighing 22,500 lb, will be retrieved from a 150-nmi circular orbit and returned to VAFB. The mission duration, including contingencies, is seven days. The crew numbers four.

Mission 4 is currently the most demanding military mission expected to be performed with the Space Shuttle. Weight increases during Shuttle development have severely reduced the payload that could be delivered to orbit. Weight reduction programs are underway and are being phased into the development program as funding and scheduling permit. Auxiliary thrust augmentation options are being studied.

The Space Shuttle capability evolution as currently depicted by NASA is outlined in Fig. 16 (NASA source). The figure shows the planned performance of the Shuttle system as the Space Shuttle Main Engine (SSME) achieves full capability and as weight reduction measures are introduced in the Orbiter (numbers OV-099 and OV-103), the External Tank (ET) and the Solid Rocket Booster (SRB). Two basic mission requirements are shown: Mission 1, a 65,000-lb payload launched due East from KSC, and Mission 4, the previously described 32,000-lb payload launched from VAFB.

The percentages associated with the SSME notation in Fig. 16 pertain to different power levels: Rated Power Level = 100%



thrust; Full Power Level = 109% thrust. The double values (i.e., 100%/109% SSME) pertain to the SSME power level sustained in a normal ascent trajectory and during an abort situation, respectively. The first four flights will operate at rated power (100% thrust) for either a normal ascent trajectory or for an aborted flight. According to current NASA plans (IDA, 1977), beginning with flight STS-5 in the third quarter of CY 1981 the main engines will be able to operate at the full power level (109% thrust) in all abort modes, and ascent trajectories at 100% thrust will be selected with this backup in mind. The net effect of this availability for abort is to allow less conservative ascent trajectories to be flown at 100% thrust that increase the payload capability by about 4000 lb. During the first quarter of 1982, an additional payload capability is to be achieved by introducing the lighter weight external tank and the lighter Solid Rocket Booster cases (equivalent to a total payload increment of about 6700 lb). In mid-calendar-year 1982 it is anticipated by NASA that normal ascent trajectories can be flown at full power (109% thrust), resulting in an additional payload gain of 9000 lb. During 1983 the delivery of the lighter-weight Orbiter OV-103 is expected to result in a further increase in payload capability of about 5000 lb.

Even after all these step increases in performance have been achieved, Orbiter OV-103 falls considerably (about 8000 lb) short of meeting the Mission 4 payload requirement at VAFB and slightly (about 2000 lb) short of meeting the Mission 1 requirement at KSC. In view of this shortfall, NASA during the past year conducted a series of analyses and reviews focused on methods for enhancing the performance of the Shuttle to meet the mission requirements. Initially, candidate configurations included solid rocket motors attached to the SRBs or to the bottom of the external tank. Of the several configurations examined in the NASA studies, two configurations (Fig. 17) emerged as being, in NASA's opinion, the most effective when

all factors were considered, i.e., development costs, cost per flight, and schedule impacts. One option consisted of an auxiliary solid rocket motor attached to each of the two Solid Rocket Boosters; the other consisted of a Titan Stage 1 liquid rocket engine (two chambers) integrated with appropriate tankage into a propulsion module attached to the bottom of the external tank as sketched in Fig. 17. In November 1979 NASA and the DoD adopted the Titan option as the baseline configuration for further study. Precise details of the configuration remain to be developed but some idea of how the installation may look can be seen in Fig. 17. The Titan engine and tankage are expendable, thus increasing the cost per flight by whatever the replacement costs turn out to be. The economics of this system have not been reviewed or studied by IDA.

Alternatives to the baseline Mission 4 with and without thrust augmentation (w/T.A. and w/o T.A.) have been studied by both NASA and the Space Division with the results shown in Table 4. In these alternatives some adjustments were made to the orbit inclination and altitude in addition to changes in the crew size and mission duration. With the rated power level (100%) used during ascent and the full power level (109%) available for an abort, the results indicate that a deploy-only, 32,000-lb delivery mission of three-days duration with a crew of two can just be accomplished with strap-on-solid-rocket-motor thrust augmentation. If full power is used for the ascent, adequate performance appears to be available for the deploy-only (2-man, 3-day) mission without thrust augmentation. It should be noted that the performance figures include a 3000-lb growth allowance (management reserve) for the Shuttle; in the event that all this margin is not used up, the remaining amount can be used as payload weight. Additional performance trade-off analyses are continuing in NASA and the Space Division. These analyses will examine the payload impact of reduction in the

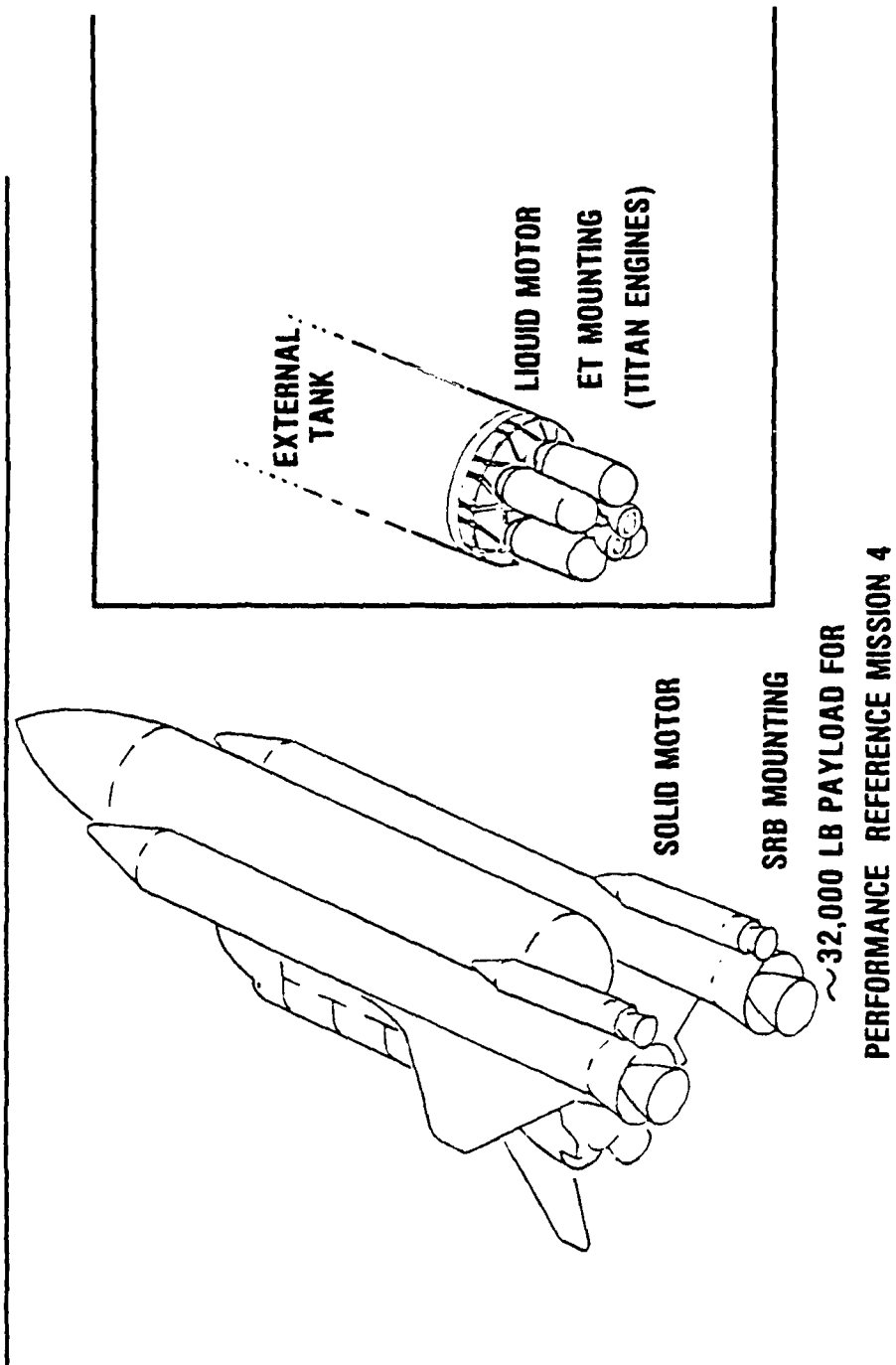

FIGURE 17. Thrust Augmentation Strap-on Motor Options  
(Courtesy NASA)

crew activity timeline, various propellant loading variations, deploy/retrieve alternatives, and operational deorbit opportunities.

TABLE 4. PERFORMANCE REFERENCE MISSION 4 (Courtesy NASA)  
(Payload Capability, lb, of OV-103)

THRUST LEVEL	BASELINE		ALTERNATES			
	4-MAN/7-DAYS		4-MAN/4-DAYS <sup>(2)</sup>		2-MAN/3-DAYS <sup>(3)</sup>	
	W/O T.A.	W/T.A. <sup>(1)</sup>	W/O T.A.	W/T.A.	W/O T.A.	W/T.A.
NOMINAL/ABORT						
109%/109%	24,000	32,000	27,000	35,000	32,200	40,200
100%/109%	16,000	24,000	19,000	27,000	24,200	32,200
100%/100%	11,500	19,500	14,500	22,500	19,700	27,700

NOTE: OV-009 2,000 lb less capability than OV-103  
OV-102 5,000 lb less capability than OV-103

NOTE:

- (1) SRB Strap-on Thrust Augmentation Option
- (2) Deploy and Retrieve
- (3) Deploy Only

The status of NASA's plans for modifying and qualifying the main engine (SSME) to full power level (109 percent thrust) was conveyed in a private communication from the MSFC Program Manager of the SSME in July 1979. He pointed out that (1) the original SSME design was for 109 percent thrust with a safety factor of 1.5, (2) all components have been proof-tested to 120 percent thrust, and (3) engines with minor modifications were to be available in September 1979 to start the 5000 sec of full power qualification runs that are expected to be completed by the end of CY 80. Plans call for three new engines and two or three rebuilt engines to be made available for the full power qualification program. Some runs at 102 percent thrust have

already been conducted successfully during the qualification to rated thrust. Extrapolations to 109 percent using present computer models show no difficulties. The great bulk of previous SSME problems in achieving rated thrust were due to manufacturing defects or were fatigue-life-related. All fixes for these were designed for 109 percent thrust.

In summary, a key factor for adequate performance for the reference Mission 4 is the thrust level at which the Shuttle main engine can be operated throughout ascent. When the full (109% thrust) power level materializes, options are available for performing some variations of Mission 4 without thrust augmentation. If recourse to thrust augmentation is made to achieve the full Mission 4 capability, the most likely configuration option appears to be a liquid boost module attached to the bottom of the external tank and employing Titan engines.

## V. LAUNCH FACILITIES AND PROCEDURES

A brief review has been made of the facilities and planned launch procedures at the Kennedy Space Center (KSC) and at Vandenberg Air Force Base (VAFB) to identify possible commonalities and redundancies and to compare the timelines for the checkout of payloads at KSC, utilizing the USAF factory-to-pad concept, with the procedures at VAFB that utilize Payload Preparation Rooms.

The nature of the launch facilities at the two sites is different. The KSC Shuttle facilities are modifications of Apollo-era facilities - including the Vehicle Assembly Building (where the Orbiter will be mated to the External Tank and Solid Rocket Motor) and the Crawler, which will transport the assembled system to the Launch Pad Complex, which also has been modified to accommodate the specific needs of the new Space Transportation System. The facilities at VAFB are newly-designed specifically for the Shuttle and exploit the unique geographic features of the site. The facilities at VAFB are being constructed to meet the required activation date--December 1983--and the Orbiter procurement schedule. The construction of the proposed safing and deservicing facility is being delayed until a second Orbiter is in the processing pipeline at VAFB. This requires that the Orbiter Maintenance and Checkout Facility (OMCF)--which is now to be located near the airfield twelve miles from the launch pad--be used as an interim safing and deservicing facility. Recheckout of the Orbiter on the pad will almost certainly be more extensive after the twelve-mile tow to the pad than it would be if the OMCF were located closer to the launch pad.

In the procurement of launch-support hardware and software, there has been close coordination between NASA and DoD. Projected workloads and security safeguards have resulted in some duplication of equipment at VAFB. Thus, duplication of KSC launch support computers at VAFB, rather than utilization of a remote linkage between the sites, is said to be required because (1) computer loads are projected to be greater than the capacity of the KSC computers, and (2) NASA software obtained by SAMTEC without cost is not compatible with the remote linkage. It appears also that the available software was not constructed by cleared personnel; the SAMTEC computer people were not aware of any requirement for secure construction of software decreed by the AACB ad hoc committee (AACB, 1977) that defined the security requirements.

In the ground handling area, duplication of certain KSC equipment for use at VAFB has not always been practicable because of the differences in which payloads are processed. At VAFB, for example, the transfer of payloads through the payload preparation room (PPR) will be by three transporters: (1) a canister to bring payloads in, (2) a strong-back to move payloads into the cells and to the payload changeout room (PCR), and (3) a payload ground handling mechanism (PGHM) in the PCR to carry the payload into the Orbiter when the PCR is moved from the PPR to the pad. The PGHM could be a carbon copy of the complex KSC PGHM (which is constructed to support payload checkout at the KSC pad) or it could be a mere strong-back with special provisions for tilting and aligning payloads with the flexing Orbiter; a considerable difference in facility cost may exist between these two extremes. AF studies to resolve these issues are underway.

These three relatively minor issues were the only ones uncovered in examination of plans for VAFB Shuttle facilities.

As to the timelines for the checkout of payloads at KSC, the principal area of uncertainty insofar as the DoD use of the Shuttle is concerned appears to be in the implementation of the factory-to-pad concept, illustrated in Fig. 18. Uncertainty exists in the time that may be available to install and check out DoD payloads in the Payload Changeout Room (PCR) on the Rotating Service Structure (RSS) at the launch pad (Fig. 19). NASA's estimate of the Orbiter ground turnaround time, when the payload installation occurs at the launch pad, appears to be based on the supposition that the user will deliver to the PCR a payload previously assembled and checked out elsewhere than in the PCR. Thus, NASA assumes that the predominant activities in the PCR are to erect the payload on the Payload Ground Handling Mechanism (PGHM), and subsequently install it in the Shuttle cargo bay. Time for this activity has been variously estimated on the order of twenty-four hours.

There are two launch-site timelines of pertinence to establishing Shuttle flight rates. One is the Orbiter turnaround time, i.e., the length of time required after an Orbiter landing to prepare it for the next flight. The other is the on-pad occupancy time required by the user to prepare his payload for installation into the Shuttle when installation occurs at the launch pad. NASA has established a turnaround time of 160 hours as an objective. However, the current (April, 1979) NASA Orbiter turnaround assessment as outlined in Fig. 20 is 233 hours. Installation of the payload takes place in the 59-hour period after fuel cell Dewar loading at 169.5 hours. In the DoD factory-to-pad concept the payload is completely checked out in the Payload Changeout Room (PCR) at the launch pad in a period of time prior to Dewar loading.

A representative DoD factory-to-pad timeline assessment for the preparation of a payload (IUS plus spacecraft) for installation into the Shuttle is shown in Fig. 21. In this

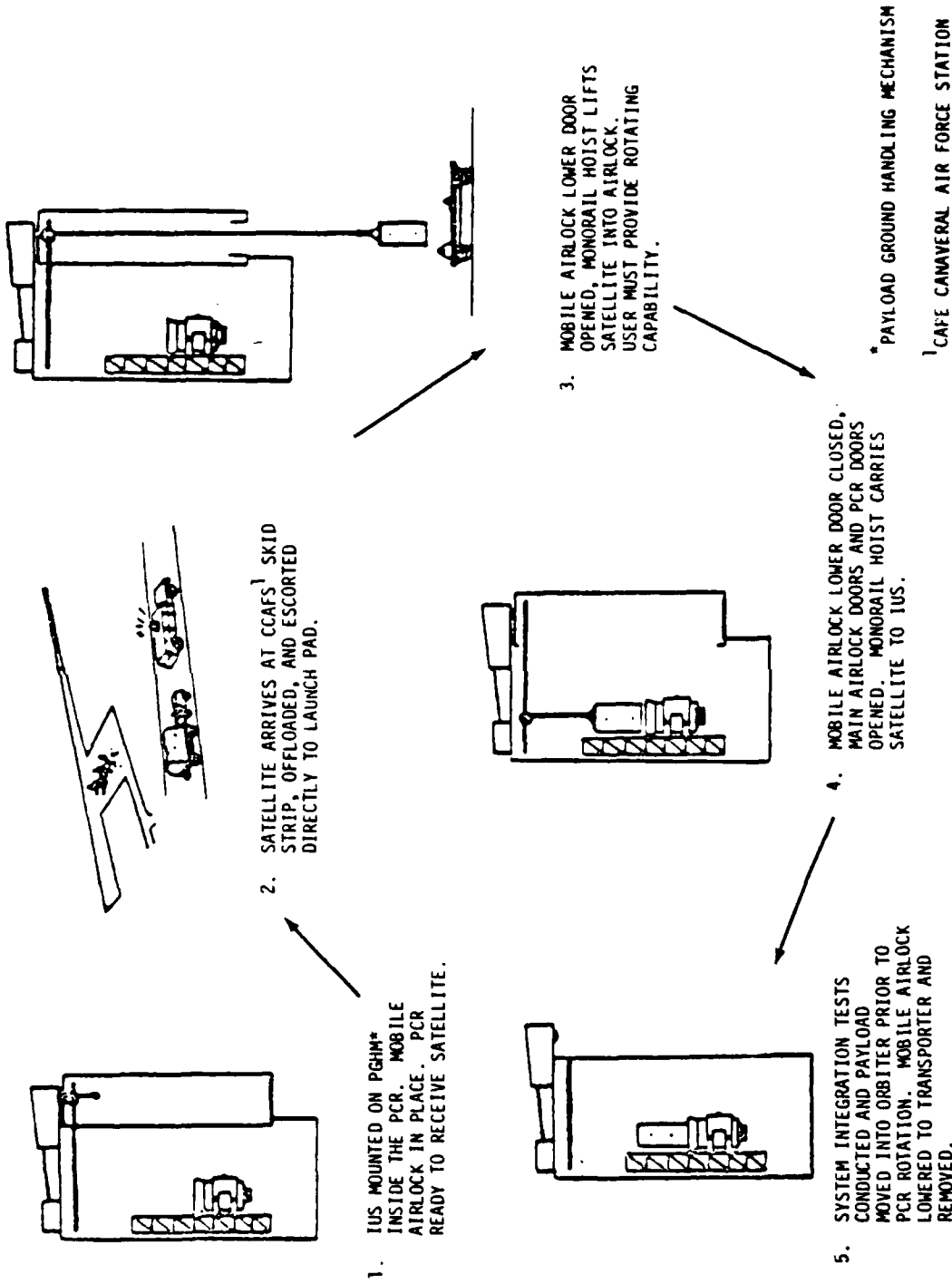

1. IUS MOUNTED ON PGHM\* INSIDE THE PCR. MOBILE AIRLOCK IN PLACE. PCR READY TO RECEIVE SATELLITE.

2. SATELLITE ARRIVES AT CCAF'S<sup>1</sup> SKID STRIP, OFFLOADED, AND ESCORTED DIRECTLY TO LAUNCH PAD.

3. MOBILE AIRLOCK LOWER DOOR OPENED, MONORAIL HOIST LIFTS SATELLITE INTO AIRLOCK. USER MUST PROVIDE ROTATING CAPABILITY.

4. MOBILE AIRLOCK LOWER DOOR CLOSED. MAIN AIRLOCK DOORS AND PCR DOORS OPENED. MONORAIL HOIST CARRIES SATELLITE TO IUS.

5. SYSTEM INTEGRATION TESTS CONDUCTED AND PAYLOAD MOVED INTO ORBITER PRIOR TO PCR ROTATION. MOBILE AIRLOCK LOWERED TO TRANSPORTER AND REMOVED.

\* PAYLOAD GROUND HANDLING MECHANISM  
<sup>1</sup> CAFE CANVERAL AIR FORCE STATION

FIGURE 18. Air Force Satellite "Factory-to-Pad" Concept (Courtesy USAF)

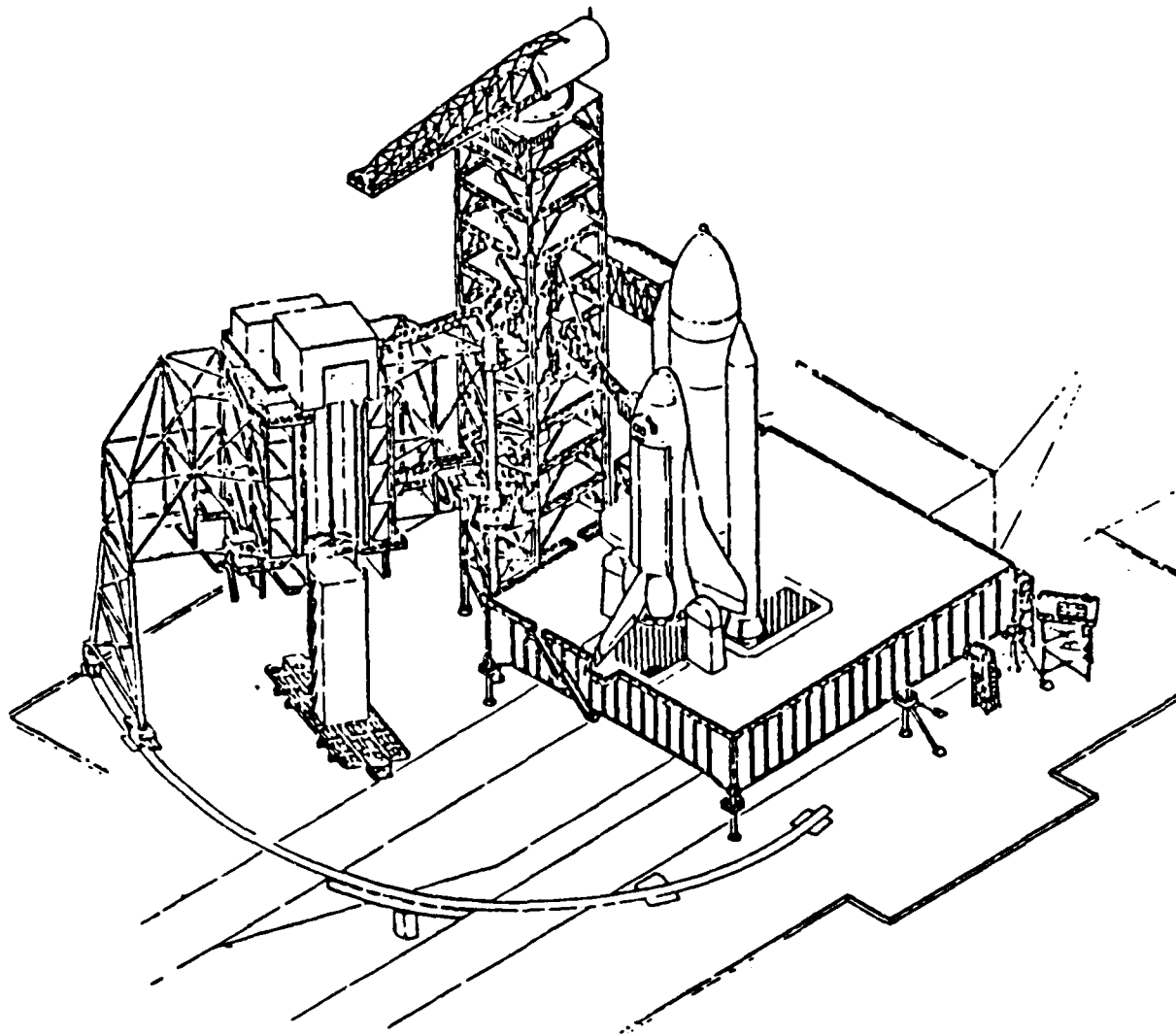

FIGURE 19. KSC Launch and Checkout Facility  
(Courtesy NASA)



example, time begins at liftoff of a previous flight, after which preparation can begin for the next flight. The first forty-six hours are dedicated to pad safing and reconfiguration and are not available for the payload activity. After the pad is reconfigured it becomes available for payload operation, which in the example shown in Fig. 21 involves 149 hours of IUS/spacecraft checkout in the PCR. The payload is transferred from the PCR into the Shuttle cargo bay after the Dewar loading, shown at 195 hours, as previously discussed in the Orbiter timeline. The concern is that the serial time required in the RSS for this "factory-to-pad" concept may impact the Orbiter timeline and result in substantial cost penalties for the DoD as well as incurring undesirable program delays. Actually, the 149 hours allowable for payload checkout appears to be too little; an examination of individual program responses to a request for timeline assessments by the Space Division\* (Table 5) indicates that the majority of the DoD programs will require considerably longer checkout times in the RSS, thus causing further impact on the Orbiter timeline. It should be noted further that doubt is expressed by some program offices about the feasibility of direct factory-to-pad processing for their programs.

The amount of time available for PCR occupancy depends on the number of pads available, the flight rate, and various contingencies introduced into the scheduling timeline. While the detailed scheduling is relatively complex when all factors are considered, some idea of the maximum available occupancy time can be obtained by a simple analysis based on current ground rules for servicing the Orbiter and the pad and the timelines previously discussed. IDA has made such an analysis to illustrate the impact of different Orbiter turnaround times and on-pad payload checkout times on the yearly flight rate. The

---

\* Briefing backup material, COL J. Boyland, 25 April 1979.

flight rates per year that can be sustained by three Orbiters on two pads are given in Fig. 22 as a function of the Orbiter turnaround time (from landing to liftoff) or of the pad accessibility time (from end-of-pad-refurbishment until beginning of loading of hazardous fluids). The ideal available times are calculated here simply by dividing the working hours per year by the number of flights per year per Orbiter or per pad and reducing the result by the unavailability times of the facilities (on-orbit time for the Orbiter or inaccessibility time for the pad). The assumed ideal even spacing of flights gives the average time available; if the spacing is less than ideal, e.g., equivalent momentarily (between two flights of the same Orbiter or from the same pad) to a higher annual flight rate, then the available time will be reduced to the value plotted for the higher flight rate.

TABLE 5. INDIVIDUAL PROGRAM ASSESSMENTS OF CHECKOUT TIME REQUIREMENTS

<u>PROGRAM</u>	<u>"FACTORY-TO-PAD" PROCESSING, hrs</u>		<u>OFF-LINE PROCESSING, hrs</u>	
	<u>SAB</u>	<u>RSS</u>	<u>SMAB</u>	<u>RSS</u>
DSCS	(?)	92 <sup>1</sup>	58	62
GPS (4 satellites)	---	> 200 <sup>2</sup>	135	160
SDS	---	> 250 <sup>2</sup>	142.5	110
DSP	70	120	150	93
SAFSP	---	350	300	70 <sup>3</sup>

<sup>1</sup> Assumes integration but no checkout in SAB.

<sup>2</sup> Direct factory-to-pad not feasible.

<sup>3</sup> No testing.



The baseline 40 flights per year specified for KSC requires an average Orbiter turnaround time not to exceed 233 hours for a seven-day mission and requires an average on-pad checkout time not to exceed 39 hours. The DoD payload-checkout-time estimate of 149 hours (Fig. 21) is compatible with a 32-per-year flight rate. If the desired 40-per-year flight rate is to be achieved, the "factory-to-pad" concept requiring an on-pad payload check-out time in the RSS upwards of 149 hours (Fig. 21), or a liftoff-to-end-checkout time upwards of 195.5 hours including a 46-hour pad refurbishment time, is infeasible with a sixteen-hour workday, five-day workweek, and an off-line payload processing facility or longer workweek is required. The conclusion reached by the Space Division, as a consequence of their own studies of payload processing requirements, is that a Satellite Assembly Building (SAB) is needed at KSC to ensure an orderly and timely checkout and installation of DoD payloads into the Shuttle if costly interference with STS operations is to be avoided.

Two options for a suitable SAB have been studied by the Space Division. One involves the use of NASA's Vertical Processing Facility (VPF) (Fig. 23); the other proposes a modification of the Solid Motor Assembly Building (SMAB), Figs. 24 and 25, incorporating a new integration area to allow the installation and checkout of payloads (either by themselves or mounted on an IUS) and permit the loading of orbital propellants in the payload. These modifications have been identified as a Phase III of upgrading the SMAB.

A tradeoff in cost between the SMAB Phase III modifications and required VPF modifications, if it is to be used for classified DoD payloads, has not been made. A communication from NASA\* stated that no detailed analysis of the VPF is to be undertaken because the requirements stipulated by the DoD so severely impacted the use of the facility by civil users and

---

\* Telephone conversation, Kennedy Space Center, 13 August 1979.

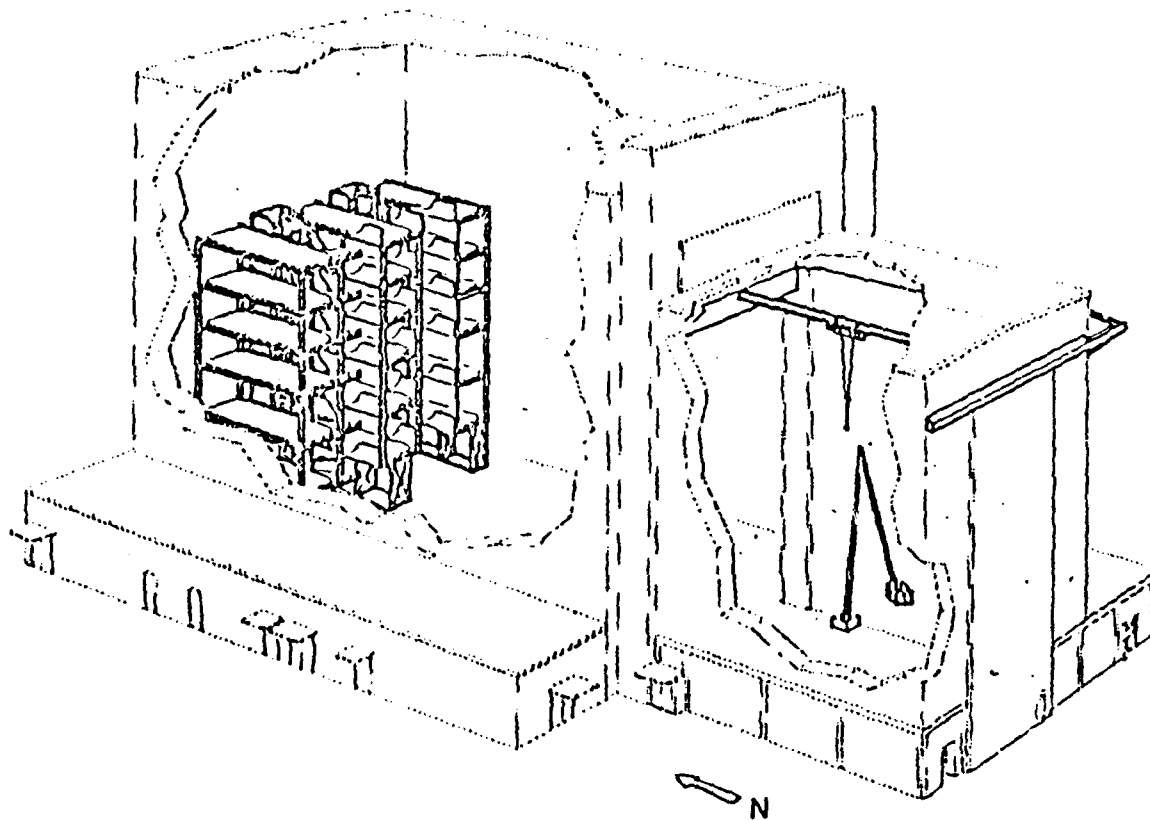

FIGURE 23. Vertical Processing Facility (VPF)  
(Courtesy USAF)

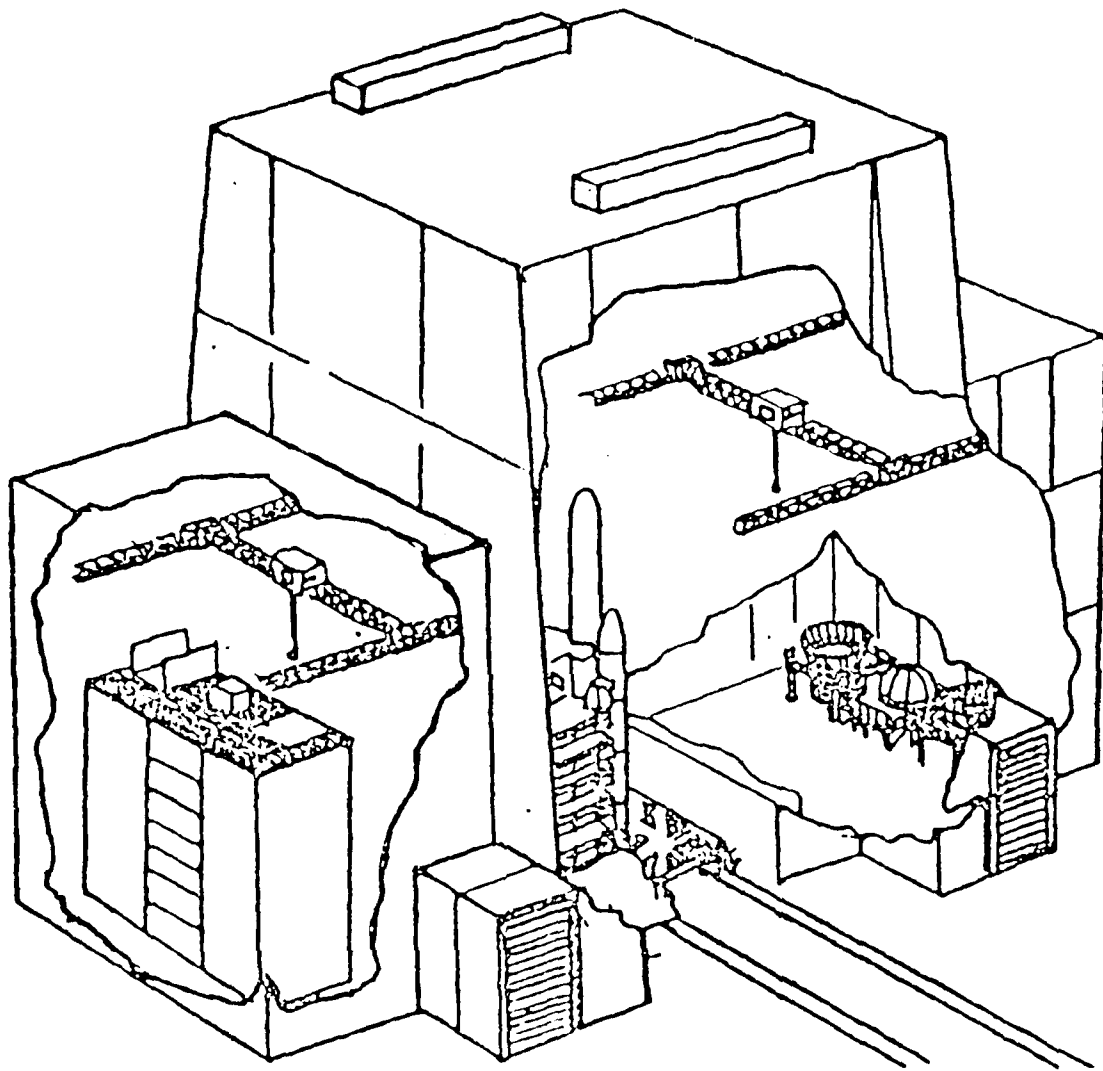

FIGURE 24. Solid Motor Assembly Building  
(SMAB) Phase III  
(Courtesy USAF)

PLAN I

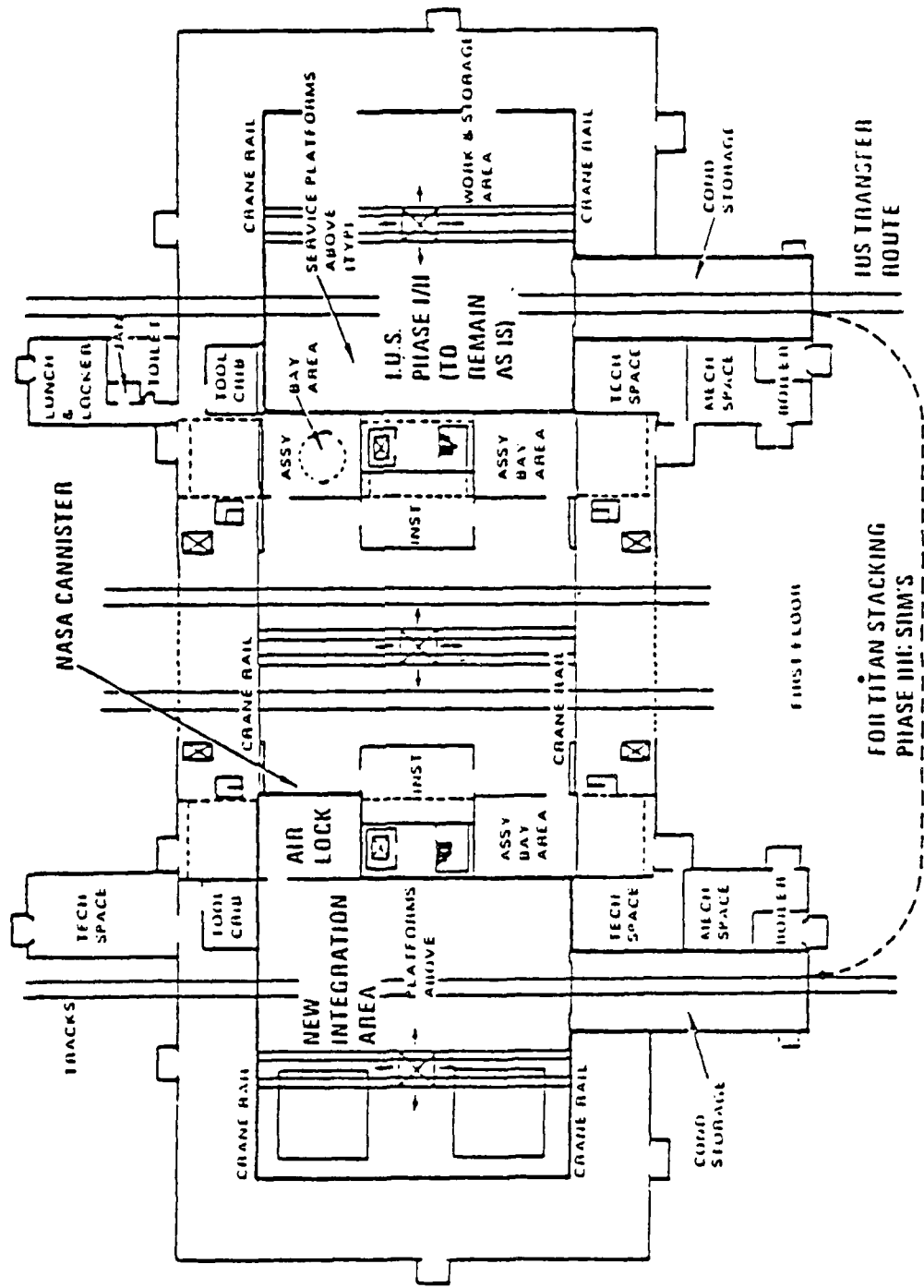

FIGURE 25. Proposed SMAB Floor Plan (Courtesy USAF)

created such high schedule risks that such an option was considered unwise. Some of the principal requirements stipulated by the Space Division are the following:

- Two isolated assembly cells and isolated levels in each cell.
- Class 100,000 clean-room environment.
- RF isolation.
- Bi-propellant loading capability.

NASA sources stated that the military missions could probably be absorbed in the flight schedule, but would require a two-shift operation, and could still convey a risk that civil programs encountering scheduling difficulty would be impacted.

Consideration of modification of the VPF to allow it to handle classified military payloads and hazardous bipropellants may be academic; modification of the VPF would necessitate shutdown of operations there for many months, requiring the integrating of all IUS/payloads in the RSS at the pad during the shutdown. Interim use of the Mobile Airlock (Fig. 18) by all (both civil and military) IUS/payloads would almost certainly be necessary. No special additional use of the Mobile Airlock has been uncovered; after the SMAB Phase III or the VPF modifications were completed, the Mobile Airlock would only serve as an extra transport canister, and no requirement has been identified for more than the two canisters planned to be purchased by NASA.

A tradeoff in cost has been made by the Space Division between the SMAB Phase III modifications and the difference between portable Interface Verification Equipment (IVE)--required if checkout is to be performed alternatively in the VPF or in the RSS in the absence of the SMAB checkout facility--and the fixed IVE for the SMAB. The FY 1979-85 cost estimates (Table 6) show a cost for the SMAB Phase III of \$18.0M and for the excess cost of portable over fixed IVE of \$27.4M, with a net savings

of \$9.4M (ignoring the saving of VPF modification costs) if the SMAB Phase III were implemented. Both cost and operational advantages appear to weigh in favor of the SMAB Phase III option.

TABLE 6. SMAB PHASE III COST SUMMARY (Courtesy USAF)  
(THEN YEAR \$ MILLIONS)

	FY 79	FY 80	FY 81	FY 82	FY 83	FY 84	FY 85	TOTAL
SMAB PHASE 3								
3600	+ 0.4	+ 1.5	+ 2.3	+ 0.7	+ 0.3			+ 5.2
3300			+12.8					+ 12.8
TOTAL	+ 0.4	+ 1.5	+15.1	+ 0.7	+ 0.3			+ 18.0
IVE CHANGES (Portable-to-fixed)								
3600		+ 1.5	- 0.2	- 1.2	- 0.6	- 1.2	- 1.2	- 2.9
3020		0	+ 1.5	- 1.9	-17.2	+ 7.4	-14.3	- 24.5
TOTAL		+ 1.5	+ 1.3	- 3.1	-17.8	+ 6.2	-15.5	- 27.4
TOTAL SMAB PHASE 3 AND IVE REDUCTION								
3600	+ 0.4	+ 3.0	+ 2.1	- 0.5	- 0.3	- 1.2	- 1.2	+ 2.3
3020			+ 1.5	- 1.9	-17.2	+ 7.4	-14.3	- 24.5
3300			+12.8					+ 12.8
TOTAL	+ 0.4	+ 3.0	+16.4	- 2.4	-17.5	+ 6.2	-15.5	- 9.4

## VI. PAYLOAD INTEGRATION

Payload integration embraces a variety of analytic activities required to verify that a payload is compatible with the Space Shuttle environment and the upper stages used, and that the Shuttle can operate safely with whatever payload combinations are placed in the cargo bay. It is a complex activity involving a number of organizations and technical disciplines and extending over several years. Major tasks to be undertaken include (1) defining payload interface requirements and performing an integrated interface analysis, (2) performing safety reviews and certifications, (3) participating in planning flight and ground operations, and (4) participating in flight readiness reviews. A typical military payload integration schedule is given in Fig. 26.\* In this example the activity extends over a period of four years. The extent of the effort expressed in man-months is outlined in Table 7\*, based on the work breakdown structure detailed in Fig. 27. Note that four organizations are involved: (1) a Payload Integration contractor (Martin-Marietta), (2) The Aerospace Corporation, (3) the IUS Spacecraft Integration contractor (The Boeing Company) and (4) NASA. The magnitude of this integration effort in terms of cost could amount to as much as 28 percent of the delivery cost for a typical DoD spacecraft according to an analysis made by the Space Division and detailed in Fig. 28.\*

There are two points to be made regarding these costs. First, NASA has questioned the need for all the optional service charges shown in Table 7. NASA claims that the services

---

\* Briefing charts -- COL C. Essmeier, May 1979.



TABLE 7. STS PAYLOAD INTEGRATION MANPOWER ESTIMATES:  
 TYPICAL SPACECRAFT WITH IUS--KSC LAUNCH  
 FOUR-YEAR INTEGRATION SCHEDULE (Courtesy USAF)

WBS ELEMENT	DESCRIPTION	MAN-MONTHS				TOTAL
		PIC	AEROSPACE	SINC	NASA OPTIONAL SERVICES	
4210	COMMON INTEGRATION EQUIPMENT REQUIREMENT/DEFINITION	18	1	4	6	29
4220	TRAINING SUPPORT	26	2	23	13	64
4230	GROUND COMMUNICATION	3	1	2	4	10
4250	INTERFACE TEST & EVALUATION	24	4	25	21	74
4260	SYSTEM PROJECT MANAGEMENT	263	83	397	181	924
4261	SYSTEM ENGINEERING	(28)	(3)	(34)	-	(65)
4262	PROJECT MANAGEMENT	(86)	(32)	(110)	(58)	(286)
4263	SAFETY	(14)	(3)	(13)	(6)	(36)
4264	INTERFACE ANALYSIS	(135)	(45)	(240)	(117)	(537)
4270	DATA AND REPORT	15	-	12	14	41
4280	SITE ACTIVATION SUPPORT	6	2	10	10	28
4290	OPERATIONS	122	15	76	6	219
4291	GROUND OPERATIONS	(21)	(2)	(22)	(6)	(51)
4292	FLIGHT OPERATIONS	(75)	(10)	(46)	-	(131)
4294	FLIGHT READINESS	(14)	(2)	(5)	-	(21)
4295	CONTINGENCY	(12)	(1)	(3)	-	(16)
3091	TOTAL WBS 4200 IUS LAUNCH OPERATIONS AND SERVICES	477	108	549	255	1389 54

12-28-79-7

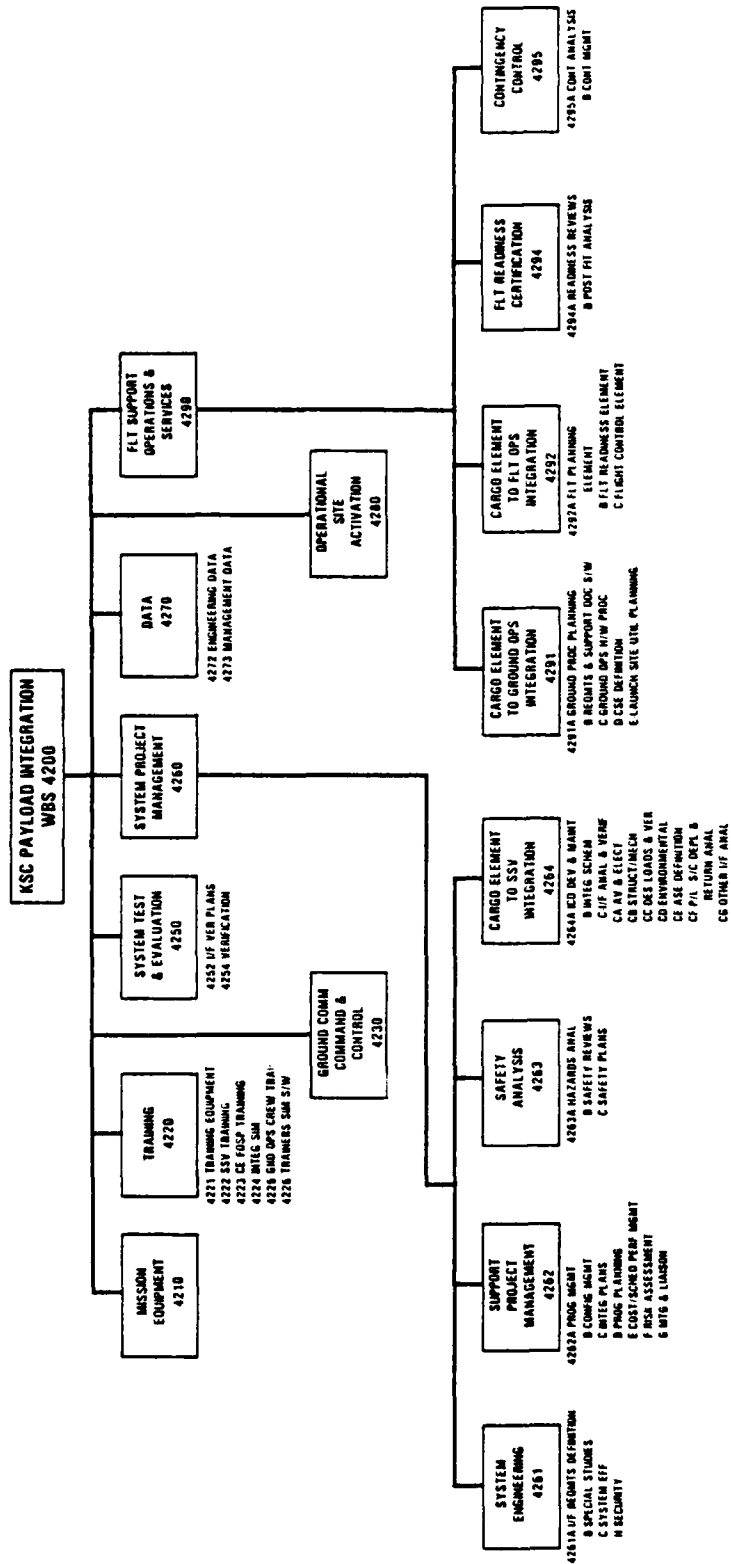

FIGURE 27. Work Breakdown Structure (Courtesy USAF)

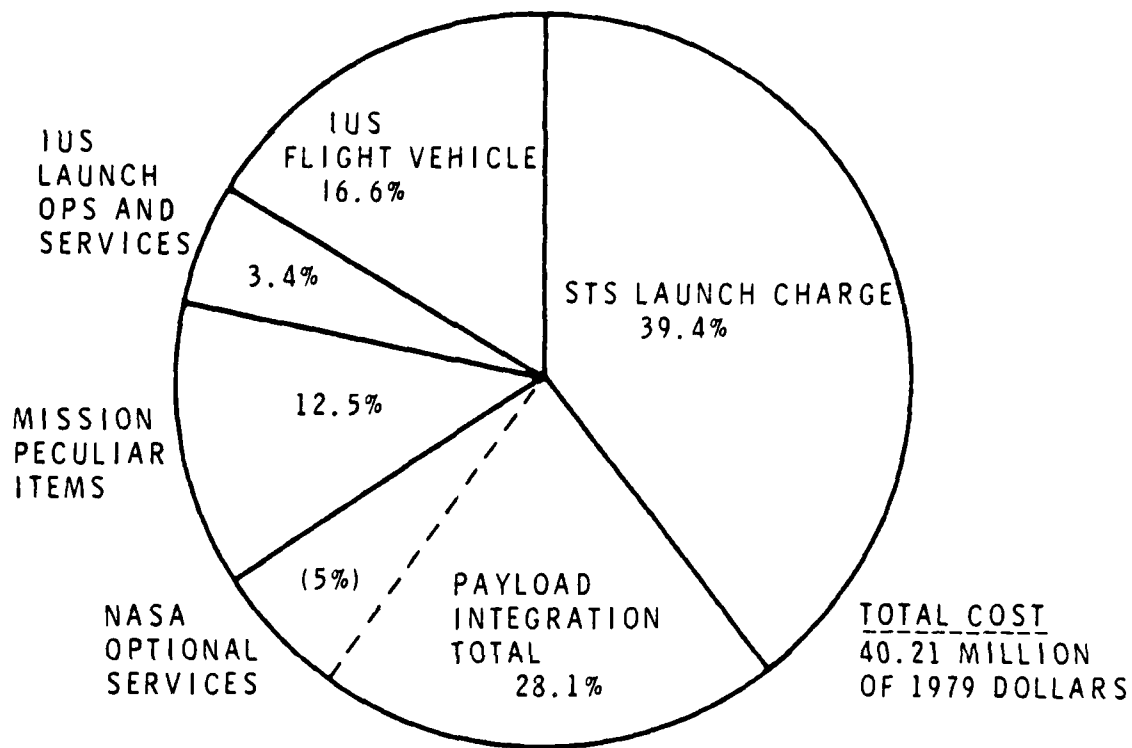

FIGURE 28. STS Delivery Cost--Typical DoD Spacecraft (Courtesy USAF)

normally included in the launch cost should take care of the kind of functions listed as optional in Table 7 and that additional charges may not be required. NASA has stated its concern about possible erroneous assumptions as to what is included in the Standard Shuttle launch price (as contrasted to optional services prices) in a recent (23 July 1979) letter to Lt. Gen. Thomas P. Stafford, Deputy Chief of Staff, Research Development and Acquisition, Headquarters, USAF.

The second point is that the redundant reviews and duplicative analyses performed by the payload integrating contractor (PIC) may be substantially reduced if the Space Division Commander's Policy were changed to acknowledge, on a selective basis, the competence of the work performed by other organizations in discharging their responsibilities. For example, independent analyses in such areas as loads, vibration, thermal stress, and contamination may need only to be undertaken where margins of acceptability are low or determined to be unsatisfactory.

NASA and the Space Division are currently reviewing procedures and requirements relating to payload integration in anticipation that means can be found to reduce payload integration costs by the elimination of duplicative activity.

It has become increasingly evident in discussions with the Space Division and NASA that reliable estimates of integration costs can only be obtained for specific case histories for actual payloads being processed through the system. For example, in a recent joint cost study by NASA, Space Division and Navy involving the potential launch of a TRANSIT satellite by the Shuttle, the greatest difference in the total cost estimates by the three organizations was reduced from over 60 percent to about 13 percent. The reduction came about primarily from close consultation on the details of certain integration activities, thus avoiding duplicate charges for similar services.

## VII. ENVIRONMENTAL SATELLITE CONVERGENCE\*

### A. BACKGROUND

Present environmental satellites--meteorological, land remote-sensing and oceanic--have developed as completely separate programs by DoD and/or NASA to meet specialized agency needs. In an effort to combine two or more of these satellite programs, the Carter administration directed, via "White House Fact Sheet on U.S. Civil Space Policy" dated October 11, 1978, that this possibility be reviewed. That portion of the policy statement pertaining to remote-sensing applications is excerpted as follows:

Weather Satellites. Separate operational requirements for meteorological data over the past two decades have led to separate Defense and Commerce's National Oceanic and Atmospheric Administration (NOAA) weather satellites. The Defense Community, NASA, and NOAA will conduct a review of meteorological satellite programs to determine the degree to which these programs might be consolidated in the 1980s and the extent to which separate programs supporting specialized defense needs should be maintained. The possibility of integrated systems for ocean observations from space will also be examined.

To meet the objectives in the President's space policy, the study activities currently in progress are: (a) the Polar

---

\* Portions of this section that cover the comparison of the DMSP and TIROS programs, were submitted on 30 March 1979, at which time full data on the NOSS program were not available. Subsequently, in May 1979, material was received (NOAA, 1979) that described a proposed NOSS program, and some preliminary comments have been incorporated in this section.

Orbiting Operational Meteorological Satellite Coordinating Board (POOMSCB), which is looking at ways to standardize (or at least converge) the next generation of DoD and NASA/NOAA meteorological satellites tentatively identified, respectively, as DMSP Block 6 and Advanced TIROS-N or Project 85, and (b) the Integrated Remote Sensing System Study (IRSSS), which has as its objective the definition of a comprehensive plan for an integrated national system for remote sensing of land, ocean and atmosphere. The OMB directive for the POOMSCB study (OMB, 1979A) requested a target date of March 1, 1979. The schedule for the IRSSS study calls for completion of the technological alternatives portion by June 15, 1979 with the organizational aspects due in mid-August, 1979. These dates are understood to be in keeping with the FY 1981 budget cycle.

A third current activity, in addition to the above, is the RFP (DMSPO, 1978) issued by the USAF/Space Division for conceptual design studies for a DMSP Block 6 meteorological satellite to meet DoD requirements. No hardware is involved in this phase, and it is understood that OMB has been assured that the USAF will take no action that would adversely affect whatever program evolves from either the POOMSCB or IRSSS studies.

One further study activity of interest, primarily to the Navy and NOAA, is a National Oceanic Satellite System (NOSS), which is proceeding concurrently with, but independently of, that of POOMSCB.

## B. CURRENT OPERATIONAL PROGRAMS

### 1. Geostationary

NOAA operates three GOES (Geostationary Operational Environmental Satellite) satellites in the western hemisphere, two of which are located at 75° and 135° W longitude. The satellites collect visible and IR images of the globe up to about 70° N and S latitude every fifteen minutes. The third GOES was

recently relocated at 60° E and is operated by the European Space Agency as part of the Global Atmospheric Research Program (GARP). Because the resolution and versatility obtainable by current sensors from geostationary altitudes is inadequate for most military and civil purposes, it is necessary to use much lower altitudes; hence, the emphasis has been on sun-synchronous, "polar orbiting", low-altitude satellites. No further discussion is given in this paper to geostationary satellites.

## 2. Polar Orbiting

The current operational "polar orbiting", low-altitude meteorological satellites are three DoD DMSP Block 5D-1, launched 9/11/76, 6/5/77 and 5/1/78, and one NASA/NOAA TIROS-N, launched 10/13/78.\* Orbital altitudes and inclinations are the same for both programs, 833 km (450 nmi) and 98.7 deg. Additional DMSP and TIROS-N/NOAA satellites are on order and planned for launch through 1985. The spacecraft bus for the DMSP and TIROS-N-NOAA was standardized by DoD and NASA in 1974, but the sensor complement is almost completely different. For example, as may be noted from the listing of sensor characteristics in Table 8 (developed from RCA, 1979), there is no commonality between the nine sensors on the DMSP Block 5D-2 and the eight listed for the TIROS-N. (Looking ahead to possible advanced DMSPs and TIROS-Ns, the total of disparate sensors rises from 17 to 27, for which performance, weight and electrical power requirements vary substantially.) However, these differences have been justified in the past because the needs of the military and civil programs vary with regard to resolution, timeliness and other requirements as well as with regard to the developmental history of two separate programs. However, the opportunity for much

---

\* Subsequent to completion of this section, two additional METSAT launches have taken place: DMSP Block 5D-1 on 6/6/79 and NOAA-A on 6/27/79.

TABLE 8. CHARACTERISTICS OF DMSP BLOCK 5D, TIROS-N, AND SEASAT SATELLITES (from RCA, 1979)

	DMSP		TIROS-N		BLOCK 5		SEASAT	REMARKS
	WGT	PWR	WGT	WGT	WGT	PWR		
<b>SPACECRAFT SIZE</b>								
DIAMETER	57 INCHES	57 INCHES	74 INCHES	74 INCHES	-	-	60 INCHES	
HEIGHT	112.5 IN.	150.5 IN.	146 INCHES	165 IN.	-	-	~42 FT.	
SOLAR ARRAY	1640 FT <sup>2</sup>	1647.5 FT <sup>2</sup>	1647.5 FT <sup>2</sup>	1647.5 FT <sup>2</sup>	-	-	-	
BATTERY	33 AMPHR	50 AMPHR	2-26.5 AMPHR	2-26.5 AMPHR	-	-	-	
PEAK POWER AVAILABLE	448 WATTS	560 WATTS	420 WATTS	>500 WATTS	-	-	1180	
NO. COVERS	2	3	3	4	-	-	8	
<b>ATTITUDE CONTROL &amp; DETERMINATION</b>								
SENSOR PRIMARY	CELESTIAL	CELESTIAL	EARTH	EARTH	-	-	-	
SENSOR SECONDARY	EARTH	EARTH	SUN	SUN	-	-	-	
ORBIT - KM/INCL	833/98.7		833/98.7		-	-	700/108	
<b>CONTROL ACCURACY</b>								
PRIMARY - Degrees	27	27	2	2	-	-	-	
SECONDARY - Degrees	7	7	-	-	-	-	-	
KNOWLEDGE	107	07	-	-	-	-	-	
<b>SPACECRAFT WEIGHT</b>								
MAXIMUM DRY IN ORBIT #	1000	1475	142	2276	-	-	-	
LIFT-OFF	~1000	< 1000	212	2743	-	-	8700	
LAUNCH VEHICLE	DELTA	DELTA	ATLAS F	ATLAS F SHUTTLE	-	-	ATLAS F	
2nd STAGE	TEM 164-4	TEM 164-4	TEM 164-15	TEM 164-15	-	-	AGENA	MAX=180 NMI TO 450 NMI - 333AM SIS PERI+525 APR + 104GPPS
3rd STAGE	TEM 164-5	TEM 164-5	-	-	-	-	-	
REACTION CONTROL %H <sub>2</sub>	2	4	37.6 (5.3 M2)	37.6 (5.3 M2)	-	-	-	
<b>OPERATIONAL INSTRUMENTS</b>								
PRIMARY SENSOR #	1	285	-	-	285	-	-	OLS-OPERATIONAL LINESCAN SYSTEM
POWER (WATTS)	-	285	-	-	-	285	-	
TOTAL PAYLOAD	1000	110	433	667	2123	-	-	
POWER (WATTS)	1150	223	130	249	-	1150	-	
IR SOUNDER	-	31 x 12	-	-	92	40	-	SSH-4 VERT TEMP & H <sub>2</sub> O VAPOR PROFILE
MICROWAVE SOUNDER	-	75 x 75	-	-	63	110	-	SSM/T-2 VT & H <sub>2</sub> O PROFILE
IONOSPHERIC SENSOR	-	14 x 2.5	-	-	73	4	-	SSIE ION & ELECTRON DENSITY
TOPSIDE SOUNDER	-	35 x 20	-	-	44	20	-	SSI ELECTRON DENSITY FROM 450 NMI TO F LAYER
PRECIPITATING ELECTRON SPECTROMETER	-	4 x 0.5	-	-	4	5	-	SSO ENERGY & DISTRIBUTION OF ELECTRONS
MICROWAVE IMAGER	-	-	-	-	753	100	-	SEA SURFACE, ICE & PRECIPITATION
GAMMA DETECTOR	-	19 x 3.5	-	-	70	16	-	SSB LOW ENERGY GAMMA DETECTION
1-1 PLANE LIMB SCANNER	-	-	-	-	51	40	-	UPPER ATMOSPHERIC TEMP & DENSITY
1-2 PLANE LIMB SCANNER	-	-	-	-	63	47	-	UPPER ATMOSPHERIC TEMP & DENSITY
MICROWAVE SCATTEROMETER	-	-	-	-	750	60	-	OCEAN SURFACE WIND SPEED & DIRECTION
LIDAR WIND SENSOR	-	-	-	-	100	2000	-	SSW 3 DIMENSIONAL TROPOSPHERIC WIND
PASSIVE MICROWAVE SOUNDER	-	80 x 40	-	-	-	-	-	SSM VERTICAL TEMP PROFILE
ATMOSPHERIC DENSITY SENSOR	-	22 x 7.5	-	-	-	-	-	SSD N <sub>2</sub> , O <sub>2</sub> & O <sub>3</sub> 100-250 km
ADVANCED VERY HIGH RESOLUTION RADIOMETER (4 CHANNEL)	-	-	60 x 26	-	-	-	-	AVHRR VISIBLE, NEAR & FAR IR '5th CHANNEL TO BE ADDED
STRATOSPHERIC SOUNDING UNIT	-	-	35 x 18	-	-	-	-	SSU TEMP. PROFILE OF STRATOSPHERE
MICROWAVE SOUNDING UNIT	-	-	47 x 30	-	-	-	-	MSU 4 CHANNEL 60 GHz TEMP PROFILE
HIGH RESOLUTION IR SOUNDER	-	-	73 x 23	-	-	-	-	HIRS/2 TROPOSPHERIC TEMP. PROFILE
DATA COLLECTION SYSTEM SOLAR ENVIRONMENT MONITOR	-	-	55 x 20	-	-	-	-	DATA COLLECTION FROM FIXED & MOBILE PLATFORM
SEARCH & RESCUE PAYLOAD	-	-	20 x 10	-	-	-	-	SEM
SOLAR BACKSCATTER ULTRAVIOLET RADIOMETER	-	-	70 x 12	-	-	-	-	SAR
EARTH RADIATION BUDGET EXPERIMENT	-	-	63 x 20	-	-	-	-	SRUN/2
SHORT PULSE RADAR ALTIMETER - PRECISION ORBIT DETERMINATION	-	-	-	-	-	-	239 x 177	ALT-GEODESY, ETC.
WIND FIELD SCATTEROMETER	-	-	-	-	-	-	132 x 140	SCAT-WIND, WAVE, ETC.
SCANNING MULTI-FREQUENCY MICROWAVE RADIOMETER	-	-	-	-	-	-	93 x 60	SMWR-WIND, WAVE, ICE THERMAL PROCESSES
SYNTHETIC APERTURE IMAGING RADAR	-	-	-	-	-	-	280 x 574	SAR-MULTI-USE
VISUAL AND INFRARED RADIOMETER	-	-	-	-	-	-	44 x 10	SR-DYNAMIC OCEAN FEATURES

NOTE: SENSOR WEIGHTS AND ELECTRICAL POWER REQUIREMENTS SHOWN AS WEIGHT (KG) x WATTS

greater standardization of sensors is apparent from this table and also taken from the sensor spectral coverages shown graphically in Fig. 29 (Lockheed, 1979).

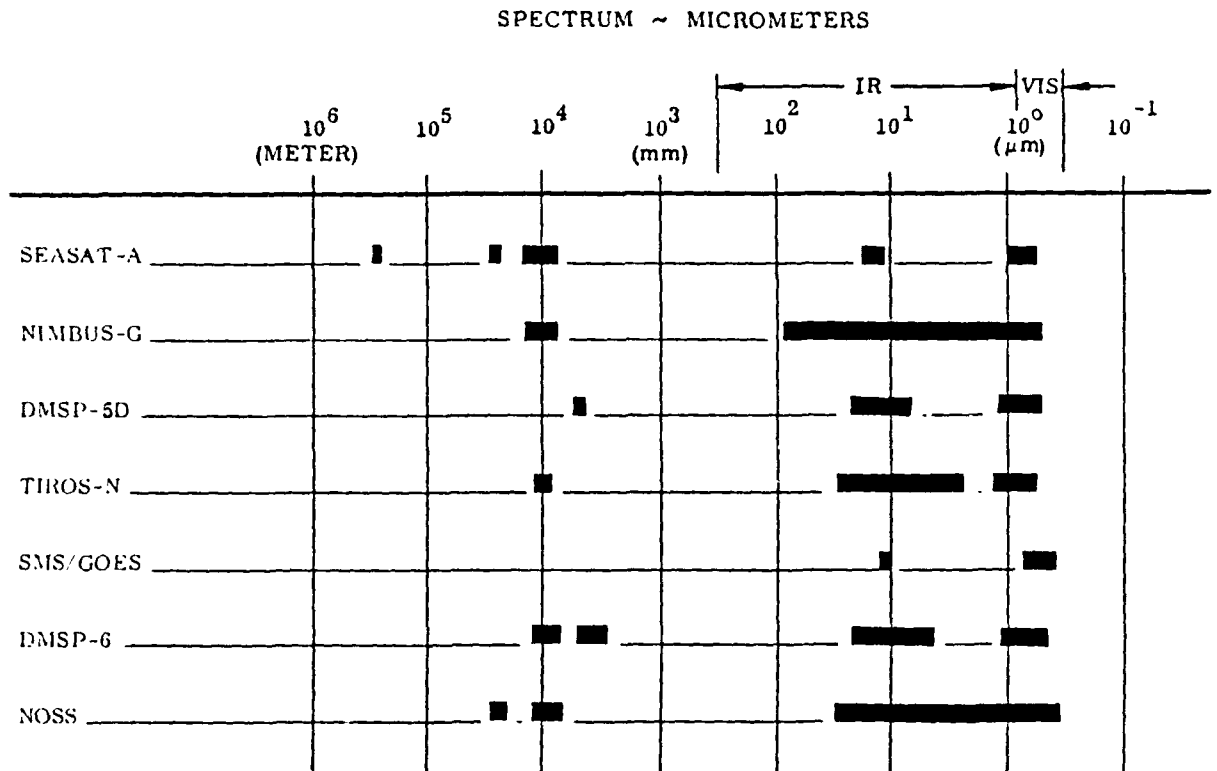

FIGURE 29. Remote Sensing Spectral Similarities  
Source: Lockheed, 1979

### 3. Oceanic Satellites

The developmental model of an operational oceanographic observation satellite system, the NASA/NOAA SEASAT 1, was launched June 26, 1978. It operated successfully for a little over three months, during which time a large quantity of data from the sensors aboard were obtained. However, a major failure of the electrical system occurred in early October 1978, which completely shut down the satellite. Additional oceanic satellites

are expected to be launched in the future, but their configuration and schedule will have to wait the results of the NOSS and IRSSS studies.

### C. METEOROLOGICAL SATELLITE DATA REQUIREMENTS

The end product of all METSAT programs must be meteorological data that are useful to the users (customers). As the technological capability of sensors, spacecraft and data reduction systems has become more sophisticated, the selection of the needs to be met and the sensors to be included in any particular program becomes more difficult. A number of pertinent references (DMSP, 1978, IDA, 1975, NOAA, 1971, DoD, 1978) were examined with the objective of preparing a list of requirements for use in this "convergence" study. However, although there were many commonalities, there were also substantial differences, and rather than trying to reconcile the differences in an independent list, it was decided to use the one prepared by the POOMSCB Working Group entitled "Summary of METSAT Data Requirements." This list, which is reproduced as Table 9, shows that, of the twelve possible requirements listed, NOAA places first priority on four, second on seven and none on one. In the DoD case, six are first, four are second and two are not required. Only three requirements carrying top priority for both agencies are the same: thermal mapping, snow cover and ice cover. (Presumably, the reason that one of DoD's first-priority requirements, cloud cover, is rated second by NOAA is that NOAA's GOES geostationary satellites provide cloud cover information with a resolution adequate for their needs, whereas DoD needs significantly better resolution; a further consideration is that GOES does not provide polar coverage.)

### D. SENSORS FOR A CONVERGED METSAT SYSTEM

As a general statement, sensor selection should be made by choosing the most versatile system to meet a particular

TABLE 9. SUMMARY OF METSAT DATA REQUIREMENTS

<u>REQUIREMENT</u>	<u>NOAA</u>	<u>DoD</u>
Imaging for meteorological use (Cloud cover)	2	1
Thermal mapping	1	1
Vertical profiling	1	2
Precipitation mapping	2	1
Snow cover	1	1
Ice cover	1	1
Radiation Balance	2	-
Space Environment	2	2
Ionospheric Electron Density	-	1
Atmospheric Constituents	2	-
Soil Moisture	2	2
Flood Expanse	2	2

1 = Highest priority

2 = Second priority

- = No requirement

NOTE: DoD requires imagery from early and mid-morning orbits to meet its mission.

NOAA requires vertical profiling at approximately six-hour intervals for input to numerical forecast models.

requirement from those sensors currently in use in the DoD and NASA/NOAA METSATs (or improvements thereof). As an example of how this selection might work out, Tables 10 and 11 are pertinent. Table 10 shows the sensors used by NOAA and DoD to meet the requirements previously shown. It will be seen that:

No. of sensors with same purpose	4
No. of other sensors for NOAA needs	4
No. of other sensors for DoD needs	5 .

Hence, for a totally converged complement of sensors that meets the needs of both agencies a total of 13 is required. Selection on the basis of minimum weight and electrical power requirements between the four that compete (except for the OLS and AVHRR for reasons discussed below) is shown in Table 11.

The OLS is a mandatory choice over the AVHRR on ground resolution needed by DoD. Stated resolutions are 1.5 nmi in the high-resolution mode and 0.3 nmi in the very-high mode for the OLS and 1.1 nmi for the AVHRR. Spectral bands are similar or could be made so. However, a check by POOMSCB with the manufacturers indicated that the AVHRR could not be modified to meet DoD requirements, whereas the OLS could be changed to handle NOAA's. Unfortunately, the OLS is a much more expensive instrument (approx. \$7.5M versus \$0.8M) so that NOAA has an incentive to stay with AVHRR rather than change in the interest of standardization.

The conclusion to be drawn from Tables 10 and 11 is that a standardized METSAT is feasible and within the weight and wattage of the Space Shuttle. Whether such a course of action (i.e., standardization) is advisable, however, depends largely on whether the reduction in integration costs for a single set of sensors instead of two different sets in the spacecraft and information systems is overbalanced by the additional cost of the agency-specific sensors required.

TABLE 10. SENSOR REQUIREMENTS FOR POST-1984

<u>INSTRUMENT</u>	<u>NOAA</u>	<u>SSA</u>
Visible/IR Imager		1 (OLS)
Visible/IR Imager	1 (AVHRR)	
Microwave Imager		1 (SSM/I)
IR Sounder	1 (HIRS)	2 (SSH)
Microwave Sounder	1 (MSU)	2 (SSM/T)
Topside Ionosonde		1 (SSI)
Energetic Particle Monitor	2 (SEM)	2 (SSJ)
Earth Radiation Budget	2 (ERBI)	
Solar Backscatter UV	2 (SBUV)	
UV Limb Scanner		2 (SSD)
Gamma/X-ray Scintillometer		2 (SSB)
Data Collection System	1 (DCS)	
Search and Rescue	3 (S&R)	
LIDAR Sounder	-	3 (SSW)

Priority ranking into 3 categories is shown

- 1 = Highest priority
- 2 = Second priority
- 3 = Potential for growth
- = No requirement

TABLE 11. POSSIBLE SENSOR COMPLEMENT FOR A  
TOTALLY "CONVERGED" DoD AND NOAA METSAT

<u>INSTRUMENT</u>	<u>NOAA</u>	<u>DoD</u>	<u>WEIGHT,</u> <u>lb</u>	<u>POWER,</u> <u>watts</u>
Visible/IR Imager		OLS	285	175
Microwave Imager		SSM/I	200	100
IR Sounder	HIRS		73	23
Microwave Sounder	MSU		47	20
Topside Ionosonde		SSI	44	20
Energetic Particle Monitor	SEM		20	10
Earth Radiation Budget	ERBI		63	20
Solar Backscatter UV	SBUV		70	12
UV Limb Scanner		SSD	60	40
Gamma/X-ray Scintillometer		SSB	19	4
Data Collection System	DCS		55	20
Search and Rescue	S&R		<u>90</u>	<u>65</u>
	Total (less LIDAR and S&R)		1026	509
LIDAR Sounder		SSW	<u>1000</u>	<u>3000</u>
			2026	3509

## E. SPACECRAFT BUS

There are a number of spacecraft buses that could be considered for a "converged" meteorological or meteorological/oceanographic satellite. The DMSP Block 5D bus can be enlarged, as can the SEASAT-A's AGENA, and there are undoubtedly others that have flown successfully and could meet the performance requirements. The NASA Multimission Modular Spacecraft (MMS) is also a candidate. This brief survey has not covered this matter in detail but there seems to be no reason why a single design of the spacecraft, less sensors, could not be achieved as was done with the DMSP Block 5D and TIROS-N, even though some of the sensors are likely to be different. In the choice between a modification of an existing flight-proven spacecraft and a new design such as the MMS, consideration should be given to proven reliability and service life as well as to relative development costs.

One additional factor to be considered is whether to require that the selected configuration have provision for the most stressing sensor--the LIDAR wind sensor. Table 11 shows that this sensor doubles the weight and more than quadruples the power. Further, the USAF RFP technical annex (DMSPO, 1978) gives the IOC for the LIDAR as "1987 to 1990." Hence, the cost of the standardized METSAT program might well be reduced by eliminating the requirement for the LIDAR sensor. After it is fully developed, and evaluated, possibly by tests in the Space Shuttle, it would be the time to consider installing it in a further development of the METSAT that might be identified as Block 6-1/2 or Block 7.

## F. LAUNCH VEHICLE

It is assumed that by 1985 the Space Shuttle will be operational from VAFB. Hence, spacecraft weight should not be as critical as it is in the present THOR/DMSP program. Length

would not be a problem for the DMSP or TIROS-N spacecraft but would be for the SEASAT/AGENA if it were desired to carry two spacecraft in tandem on a single launch. This tandem-operation issue is significant if it turns out that DoD requirements dictate that DoD have its own spacecraft and for economy reasons the Shuttle should be used to launch two meteorological spacecraft in a single flight. However, if the diameter of the spacecraft can be kept down to 6-7 ft, the length problem disappears and two could be carried side by side. In fact, the payload capacity of the Shuttle would probably permit more than two such spacecraft to be carried.

The  $\Delta V$  requirements for transfer from the nominal 150-nmi Shuttle orbit to the 450-nmi operational orbit are relatively moderate, requiring perigee and apogee burns totaling a little over 1,000 ft/sec. The Shuttle performance curves were examined to determine if the Shuttle itself, using the maximum number of OMS kits, could deliver the spacecraft directly to orbit. A payload capability of about 5,000 lb is shown, but, with the current overweight problem of the Shuttle, this is considered too marginal to consider at this time, although it may be kept in mind for the future.\*

The Goddard/Fairchild Multimission Modular Spacecraft (MSS), which has provision for an add-on propulsion module, could provide the necessary perigee/apogee velocity increments as well as acting as the spacecraft bus.

An alternate orbit transfer vehicle (OTV) concept that could be fully reusable would be a new upper stage having a

---

\* Current NASA studies of performance enhancement of the Space Shuttle necessary to permit it to meet Mission 4 requirements from VAFB are discussed in Section IV. Either strap-on solid motors or the preferred liquid boost module will bring the Shuttle's payload capability to the 450-nmi/98.7 deg orbit back to or possibly slightly more than the original 5000 lb. Such a capability, which would eliminate the need for an OTV for the METSAT program, is projected for the 1985 time period.

four-burn liquid-propellant propulsion system--two burns used to move the payload from the Shuttle to the operational orbit and two to return it to the Orbiter. (One candidate for such a stage might be a modified IUS in which the two solid rocket motors are replaced by a single liquid-propellant rocket engine.)

#### G. GROUND FACILITIES

The DMSF and NOAA programs have developed their own separate ground-receiving, data-reduction and weather-information-dissemination systems. In view of the wide differences in user requirements, it is not apparent that it is necessary or cost-effective to consider standardization of ground facilities, even if there were no security aspects to consider.

#### H. PROGRAM COST CONSIDERATIONS

##### 1. Comparison of Program Options

A cursory IDA cost estimate for a 10-year program covering development, procurement and operations gave the following results for three options as follows:

Option		
A	B	C
Modified RCA bus to take both DoD and NOAA sensors. Two operational satellites for each agency	New "converged" bus with standardized set of sensors-- 3-satellite operational system	Same as Option B, but separate satellites for DoD and NOAA-- similar to Option A
Baseline cost	$\Delta = - 10\%$	$\Delta = + 9\%$

Comparing Options B and C, Option B has a cost saving of approximately 18 percent.

No allowance was made in the above estimate for the possible effect of the changes in ground facilities for data reception, processing and dissemination. However, if a common system were decided on, the incremental costs for ground facilities would be about the same for all three options. It is understood that POOMSCB estimates a cost saving of about 20 percent.

## 2. Retrieval for Ground Repair, or Orbital Maintenance

Because the Space Shuttle has the ability to rendezvous with low-altitude satellites, the possibility of using it to retrieve a satellite for ground repair or to accomplish orbital resupply or repair has been proposed. Some of the factors to be considered in evaluating this use of the Shuttle are discussed below:

- a. Retrieval and Repair/Refurbishment. In this mode the Shuttle would retrieve a low-altitude environmental satellite and return it to the ground for repair, refurbishment and relaunch. This could be accomplished only if (a) the spacecraft could retract and furl its power panels, antennas, etc. (or, alternatively, blow them off) and if the Shuttle has the capability to attain the spacecraft orbit, or (b) if the spacecraft had the propulsion to descend to the standard Shuttle orbit for rendezvous. In either case, the Shuttle's Remote Manipulator Arm (or equivalent) would grasp the spacecraft and maneuver it into a cradle in the cargo bay for return to earth. A study of the economics of this approach is needed to determine if this is a likely candidate in view of the cost per Shuttle flight in relation to the probable cost of the spacecraft.

- b. Repair/Resupply in Orbit. Resupply of liquid propellants from tanks in the Orbiter may be a straightforward procedure if the Shuttle can attain the spacecraft orbit. However, to repair a malfunctioning spacecraft means that it would have to be designed with replaceable modules for the critical components, perhaps along the lines of NASA's MMS project. Here again, as in the ground repair mode, the same issues regarding ability of the Shuttle to reach the spacecraft orbital altitude and the relative cost of the flight, which would probably have to be a dedicated flight, would be controlling factors. Also, the possibility must be considered that the ground diagnosis of the malfunction might be faulty and therefore the orbital repair could not be accomplished.

Hence, from an overall standpoint the concept of repairing or resupplying a spacecraft of this type either on the ground or in orbit does not appear promising.\* Emphasis on component reliability to achieve lower cost through longer life appears to be more productive.

#### I. FREQUENCY AND TIMELINESS OF GROUND COVERAGE

The number of METSATs in orbit and their times of equatorial crossing is vital to DoD and NOAA missions. The POOMSCB study has defined a converged system that reduces the number of satellites required in an operational system from four (for

---

\* This conclusion, which is contrary to that of IDA Paper P-1366 for Mission 4 payloads, is due to the effect on Space Shuttle performance of the higher-altitude orbit for the DMSP- and NOAA-type payloads. Mission 4 payload is to be delivered to a 150 nmi/98 deg orbit as compared to 450/98.7.

separate DoD and NOAA systems, called here the baseline system) to three, as follows:

Local Time and Direction of Equatorial Crossing

<u>Baseline System</u>	<u>Converged System</u>
0730-N (DoD)	0630-N
0730-S (NOAA)	1030-N
1030-N (DoD)	1430-N
1500-N (NOAA)	

From the above trend in convergence of timing, the question arises as to whether, if a three-satellite system is acceptable to both DoD and NOAA, it would be possible to go one step further and eliminate the 10:30 one, thereby reducing the METSAT system to two satellites. This study can only raise this question, not answer it. However, as we understand the different uses to which the two organizations put the meteorological data we are inclined to believe that the answer is negative and that the three-satellite system is the minimum for effective operation.

J. SYSTEM SECURITY

This subject has been looked at in only a cursory manner in this paper. It is understood that current DMSP Block 5D and TIROS-N satellites have provision for and may actually use encryption/decryption equipment to provide security. The USAF/SAMSO Block 6 Technical Requirements document (DMSPO, 1978) contains the following:

- 7.1 (b) - Encryption and authentication shall be provided for the command link.
- 7.1 (c) - Encryption shall be provided for the downlink telemetry (for both housekeeping functions and mission data).

In addition to these requirements for a new DMSP program, it is of interest to note that DMSPC, 1978 also states that

5.0 (c) - Protection shall be provided against laser, nuclear and conventional ASAT threats.

During discussions with NOAA, it was learned that current METSATS have equipment that can be commanded to render them inoperative in certain circumstances to prevent unauthorized use.

#### K. MANAGEMENT RESPONSIBILITY

The OMB letter (OMB, 1979A) requesting the POOMSCB study of DMSP and TIROS-N convergence asked that the question of institutional/operational management factors be considered as well as those of a technical nature. The issuance by USAF/Space Division of the RFP for conceptual studies of a Block 6 METSAT might appear to be a "jumping-of-the-gun" by the Air Force. However, it is understood that this is not the case but rather a desire to obtain inputs from a number of qualified industrial firms from which the best possible specification for the development phase of the next generation METSAT can be prepared. No information as to the recommendations of POOMSCB regarding assignment of management responsibility was available to us during the course of the study and since both the USAF and NASA/NOAA have the capability to manage a program of this magnitude, the choice of agency will have to be made on factors other than technical. Among these are security and survivability for the military and international data dissemination and commercialization for the civil sector.

#### L. NOSS PROGRAM CONSIDERATIONS

The National Oceanic Satellite System (NOSS) interagency study (NOAA, 1979) defines the program as a "limited operational demonstration of satellite sensing of oceanic phenomena."

In one sense, it is a follow-on to SEASAT-1 which, unfortunately, failed in October 1978 after only three months in orbit. However, NOAA is now proposing it as a completely new and more versatile project following the A-109 procurement program.

For a preliminary evaluation of the opportunities and difficulties of combining weather and oceanic satellites, two parameters are used: (1) orbit altitude and inclination and (2) sensor complement.

#### 1. Orbit Characteristics

The polar-orbit METSATS require a sun-synchronous orbit at 830 km/98.7 deg. They also have a demanding schedule of time of equatorial crossing (i.e., 7:30 AM South to North, etc.) to collect data on the timely basis needed by both DoD and NOAA for local meteorological forecasts.

Orbit tradeoff studies are required (NOAA, 1979), based on sensor options, before a decision is made as to orbit altitude or inclination. The following is quoted from that reference, pp. II-2 and II-3:

The orbit considered for the NOSS mission is 600 to 900 km, circular and polar. The 600- to 900-km altitude range can easily be achieved and maintained by a Shuttle launch from the Western Test Range, a Teleoperator Orbit Transfer, and can be kept on station using a PM-I. The circular orbit is used to guarantee uniform quality of the data, and the polar orbit with an inclination of between 85 and 110 deg will ensure that the SMMR "sees" the polar ice cap(s). Only one sensor (the colorimeter) would yield better data if flown in a sun-synchronous orbit.\*

Hence, it appears likely that NOSS sensor performance will be degraded if METSAT orbital parameters are used.

---

\* In a discussion with NASA project personnel on 8/6/79, it was learned that choice of orbital characteristics has narrowed to a nominal 800-km altitude and 87-93 deg inclination.

## 2. Sensor Complement

The oceanic characteristics the NOSS program is intended to measure are the following:

- Wind--Speed, Direction
- Sea Surface Temperature--Global, Local
- Waves (Sea State)--Height, Amplitude, Direction
- Ice--Cover, Thickness, etc.
- Water Mass Definition--Chlorophyll, Turbidity
- Horizontal Surface Currents--Speed, Direction

Table 12 (reproduced from NOAA, 1979, Table 1.1, p. IV-2) gives accuracy requirements, desired frequency of observation, etc. It will be noted that for optimum utility the wind and wave measurements should be made every twelve hours with a transmission delay not to exceed three hours; frequency of observation of the other items is one to three days.

The sensors required to make the measurements from which the above oceanic characteristics can be derived are also listed in NOAA, 1979 as follows:

- (a) ALT - Altimeter
- (b) SCAT - Scatterometer
- (c) SMMR - Scanning Multifrequency Microwave Radiometer
- (d) CZCS - Modified Coastal Zone Color Scanner
- (e) AVHRR - Modified Advanced Very High Resolution Radiometer

Comparison of these sensors with those listed in Tables 10 and 11 shows very little correlation. For example, the NOAA and NOSS AVHRR's might be made compatible, but the needed 100 resolution requires the OLS (Operational Linescan System) of the DMSP Block 5D series and hence negates this possible convergence.

AD-A093 198

INSTITUTE FOR DEFENSE ANALYSES ARLINGTON VA SCIENCE A--ETC F/6 22/2  
CONTINUING ISSUES (FY 1979) REGARDING DOD USE OF THE SPACE TRAN--ETC(U)  
DEC 79 R G FINKE, C J DONLAN, G W BRADY MDA903-79-C-0018

UNCLASSIFIED

TDA-P-1451

IDA/HQ-79-21729

NL

1-2  
40  
11  
10



END  
DATE  
FILMED  
2 89  
DTIC

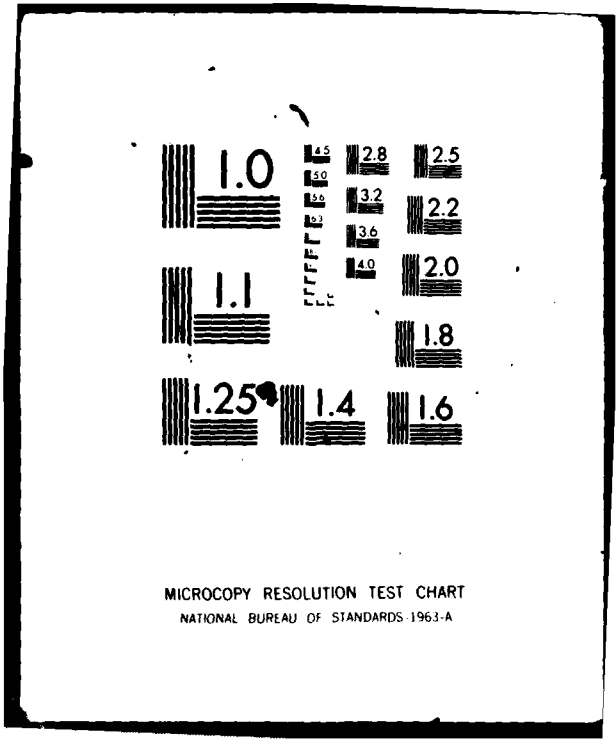

MICROCOPY RESOLUTION TEST CHART  
NATIONAL BUREAU OF STANDARDS 1963-A

TABLE 12. NOSS PRIMARY OUTPUTS  
Source: NOAA, 1979

<u>Parameter</u>	<u>Precision</u>	<u>Absolute Accuracy</u>	<u>Range</u>	<u>Frequency</u>	<u>Delay</u>	<u>Model Grid Size</u>	<u>Horizontal Resolution</u>
<u>Wind</u>							
Speed	0.5 m/s	2 m/s	0 to 50 m/s	12 hrs	3 hrs	200 km	25 km
Direction	5°	10°	0° to 360°	12 hrs	3 hrs	200 km	25 km
<u>Sea Surf. Temp.</u>							
Global	0.25°C	1.0°C	-2°C to 35°C	3 days	12 hrs	200 km	25 km
Local	0.10°C	0.5°C	-2°C to 35°C	1 day	12 hrs	10 km	10 km
<u>Waves (Sea State)</u>							
Sign. Wave Ht.	0.3 m	0.3 m	0 to 25 m	12 hrs	3 hrs	100 km	25 km
Amplitude							
Components	0.7 m	0.7 m	1 to 8 m	12 hrs	3 hrs	100 km	25 km
Wave Length							
Components	10%	10%	6 to 1000 m	12 hrs	3 hrs	100 km	25 km
Direction	10°	10°	0° to 360°	12 hrs	3 hrs	100 km	25 km
<u>Ice</u>							
Cover	15%	15%	0 to 100%	3 days	12 hrs	20 km	20 km
Thickness	2 m	2 m	0.25 to 50 m	3 days	12 hrs	50 km	50 km
Age	New, 1st yr	New, 1st yr	0 to 3 yrs	3 days	12 hrs	20 km	20 km
	multi-yr	multi-yr					
Sheet Height	0.1 m change	0.5 m change	-5 to +5 m/yr	1 yr	30 days	TBD	10 km
Bergs	N/A	+2 km of true location	N/A	2 days	12 hrs	N/A	0.1 km
<u>Water Mass Definition</u>							
Chlorophyll	10% (mg/m <sup>3</sup> )	Within factor of 2	0.1 to 100 mg/m <sup>3</sup>	2 days	8 hrs	TBD	0.4 km
<u>Turbidity</u>							
	0.1 PPM	Lo, Med, Hi	0 to TBD	1 day	10 hrs	TBD	0.4 km
<u>Horizontal Surface Currents</u>							
Speed	5 cm/s	5 cm/s	0 to 250 cm/s	1 day	1 day	100 km	20 km
Direction	10°	10°	0° to 360°	1 day	1 day	100 km	20 km

### 3. Convergence Possibilities

The DoD and NOAA program for a common operational METSAT system, for the 1985 time period and beyond, while not yet firm, is taking shape and is almost certain to become a definite program to follow DMSP Block 5D-2 and NOAA-A to -G. Weather forecasting for both military and civil purposes is an established requirement, and METSATS of both geosynchronous (GOES) and polar-orbiting types provide a powerful tool for meteorologists for more timely, versatile, accurate and long-range forecasts.

Oceanic satellites, on the other hand, still have more of a scientific and developmental rather than operational flavor. This is not to say that there are not important DoD missions that an oceanic satellite such as NOSS, either as defined in NOAA, 1979 or an improved version thereof, could perform, but rather that characteristics of a tactical or strategic nature seem to be lacking. Therefore, the plans presented in NOAA, 1979 for a "limited operational demonstration of satellite sensing of oceanic phenomena" appear the logical course of action. As experience is gained with a prototype NOSS, it would be timely for DoD to consider whether its needs will be met by further NOSS launchings or whether a separate program, possibly classified, will be required.

Results of the Integrated Remote Sensing System Study (IRSSS) being conducted by NASA, NOAA and DoD in response to the directive from OMB (OMB, 1979B) had not been released at the time of this writing. It is believed unlikely, however, that the study will recommend a single satellite program to handle meteorological, oceanographic and land observation missions. Possibly, a common spacecraft bus along the lines of the MMS will be proposed that can be fitted with a mission-specific complement of sensors.

## M. GENERAL COMMENTS

This limited study of the "opportunities and difficulties in combining weather and oceanographic satellites" has reviewed the military and civil programs and requirements for meteorological and oceanic data from polar-orbiting satellites. A number of comments and suggestions pertinent to the task directive are contained in the body of this section and summarized as follows:

1. There does not seem to be any insurmountable obstacle to accomplishing complete standardization or convergence of spacecraft, sensors or orbit for a joint DoD/NOAA METSAT system for use in the 1985 and beyond time period. A very preliminary program cost estimate indicates that a cost saving between 5-15 percent is possible for a 10-year program; however, this should be verified by a detailed analysis.
2. Both the POOMSCB study and the requirements of the DMSP Block 6 (DMSPO, 1978) contemplate that the spacecraft bus and some, but not all, of the sensors be standardized. A question arises whether the effect of different sensor complements on spacecraft design and test costs has been evaluated thoroughly enough in comparison with the completely converged system suggested in the preceding paragraph.
3. One of the major uncertainties in design of the converged DMSP Block 6/NOAA 85 METSAT is whether to make provision for future installation of the LIDAR wind sensor, which according to DMSPO, 1978 is "presently under study--IOC 1987 to 1990." Since this sensor will double the weight and triple the wattage for all the other sensors combined, its inclusion will have a major effect

on the spacecraft bus, placement of sensors, etc. An early decision as to the inclusion of this sensor should be made.

4. Consideration of the means for transferring the new METSAT from the Shuttle orbit should include a reusable propulsion stage as well as expendable perigee and apogee rocket motors. One such stage might be a new reusable upper stage, possibly a modification of the IUS, using a four-burn rocket system with a liquid-propellant engine.
5. A major policy uncertainty may arise as the result of the GSFC Integrated Sensor study; the result of this study may lead to a further effort to converge meteorological, oceanographic and LANDSAT missions into a single system. The outcome of such an overall standardization could be that the spacecraft would become so heavy and loaded down with a multiplicity of sensors that it would be neither operationally efficient nor cost effective. Also, the special orbital and equatorial crossing needs for the METSAT mission could be compromised. Hence, a careful balance must be struck between possible budgetary advantages of standardization and operational considerations.
6. Because of wide differences in orbital characteristics, measurements desired and hence sensor complement, it does not appear either practicable or efficient to converge the NOSS mission into the future DMSP Block 6/NOAA 85 METSATS. However, there is sufficient similarity in the two programs that a common spacecraft bus, possibly along the lines of the MMS, could be designed that would provide a significant reduction in development costs.

## REFERENCES

- AACB, 1977: AACB, *Report of the AACB Ad Hoc Shuttle Security Group on Shuttle Mission Planning, Simulation, and Flight Control with Classified Payloads at the Johnson Space Center (U)*, November 17, 1977 (SECRET). ✓
- Aerospace, 1978: Aerospace Corp., *Five-Year Plan for Space Test Program (U)*, Report No. TOR-0078 (3506-01)-1, H.E. Frank Wang, R.G. Knauss, R.E. Underwood, and L.H. Weeks, 28 August 1978 (UNCLASSIFIED).
- AF/RDSL, 1978: Attachment, CSE Development Plan, *Early Exploitation of the Space Shuttle for Space Tests (U)*, MAJ R.R. Wilde, AF/RDSL, 1978 (SECRET). ✓
- ANSER, 1979: Analytic Services Inc., *Common Support Equipment for Military Manned Experimentation in Shuttle*, R.D. Mercer and J.C. Baker, Space Division Note SpDn 79-4, April 1979.
- BAC, 1978: British Aerospace Dynamics Group, *Spacelab-Pallet Presentation in the U.S.A. - November 1978* (UNCLASSIFIED).
- DMSPO, 1978: Annex A (to RFP)--DMSP Block 6, Technical Requirements Document--October 1978, Deputy for Defense Meteorological Satellite Systems, USAF/SAMSO.
- DoD, 1978: *Military Operational Requirements for Meteorological Data from Satellites*, DoD document, 1978 (UNCLASSIFIED).
- GE, 1978: General Electric, *STS Cradle Comparative Analysis, Final Report*, July 1978 (UNCLASSIFIED).
- IDA, 1975: Institute for Defense Analyses, *Survey of Earth-Oriented Civil Satellite Sensor Programs (U)*, IDA Paper P-1074, June 1975 (CONFIDENTIAL). ✓
- IDA, 1977: Institute for Defense Analyses, *Current (FY '77) Issues Regarding the DoD Use of the Space Transportation System (U)*, IDA Paper P-1287, Reinald G. Finke, Charles J. Donlan, and Robert S. Swanson, December 1977 (SECRET). ✓

IDA, 1978: Institute for Defense Analyses, *Enhanced Military Missions Through Use of the Space Shuttle (U)*, IDA Paper P-1366, Reinald G. Finke, Charles J. Donlan, George W. Brady, and Robert S. Swanson, December 1978 (SECRET). ✓

Lockheed, 1979: Lockheed DMSP Study Status Report, January 1979.

MBB, 1979: Messerschmitt-Bölkow-Blohm GMBH Space Division, *Pallet Type Structures for Different STS Mission Modes*, Final Presentation/Report, July 1979 (UNCLASSIFIED).

NOAA, 1971: *Federal Plans for Meteorological Data from Satellites*, NOAA, Department of Commerce, May 1971.

NOAA, 1979: NOSS--National Oceanic Satellite System, 23 March 1979, Joint Effort by NASA, DOC/NOAA and DoD/Navy, Air Force and Army (Available to IDA in May 1979).

OMB, 1979A: *Review of Meteorological and Oceanic Satellite Programs*, OMB Memorandum to DoD (Brown), DoC (Krebs), and NASA (Frosch), 1 February 1979.

OMB, 1979B: *Integrated Remote-Sensing Systems Study*, OMB Memorandum to NASA (Frosch), 1 February 1979.

RCA, 1979: RCA chart comparing DMSP Block 5D and TIROS-N, January 1979.

SD, 1979: Space Division Space Test Program Office, *Preliminary Description of the STP Sortie Support System*, 1 June 1979 (Draft Request for Proposal).

TRW, 1978: TRW, *STP STS Cradle Comparative Analysis Study, Final Report*, Report No. 31933-6003-TU-00, 30 June 1978 (UNCLASSIFIED).

END

DATE  
FILMED

2 - 8/1

DTIC