

AD A094023

ETHIC
S
D

80 0 21 082

This report and its contents are used for... operations... and any obligation... furnished... or other... in any manner... or conveying any... or with any patented invention...

For a complete listing of this report from All Tech Aerospace Medical Research Laboratory. Additional copies may be purchased from:

National Technical Information Service
1215 Jefferson Davis Hwy
Springfield, Virginia 22161

Federal Government agencies and their contractors registered with Defense Documentation Center should direct requests for copies of this report to:

Defense Technical Information Center
Cameron Station
Alexandria, Virginia 22304

TECHNICAL REVIEW AND APPROVAL

ATMRL-TR-80-118

This report has been reviewed by the Office of Public Affairs (PA) and is releasable to the National Technical Information Service (NTIS). At NTIS, it will be available to the general public, including foreign nations.

This technical report has been reviewed and is approved for publication.

For the Director



Director, All Tech Aerospace Medical Research Laboratory

SECURITY CLASSIFICATION OF THIS PAGE (When Data Entered)

REPORT DOCUMENTATION PAGE		READ INSTRUCTIONS BEFORE COMPLETING FORM	
1. REPORT NUMBER: 18 AFAMRL-TR-80-118	2. GOVT ACCESSION NO. AD-A094 023	3. RECIPIENT'S CATALOG NUMBER	
4. TITLE (and Subtitle) SAM SYSTEM PERFORMANCE EVALUATION: E-Q DATA FOR HUMAN OPERATOR MODEL DEVELOPMENT.	5. TYPE OF REPORT & PERIOD COVERED 9 Technical Report	6. PERFORMING ORG. REPORT NUMBER	
7. AUTHOR(s) Evan P./Rolek	8. CONTRACT OR GRANT NUMBER(s) 13 F33615-79-C-0500		
9. PERFORMING ORGANIZATION NAME AND ADDRESS Systems Research Laboratories, Inc. 2800 Indian Ripple Road Dayton, Ohio 45440	10. PROGRAM ELEMENT, PROJECT, TASK AREA & WORK UNIT NUMBERS 62202F, 6893-04-60 17		
11. CONTROLLING OFFICE NAME AND ADDRESS Air Force Aerospace Medical Research Laboratory, Aerospace Medical Division, Air Force Systems Command, Wright-Patterson AFB, Ohio 45433	12. REPORT DATE November 1980	13. NUMBER OF PAGES 128	
14. MONITORING AGENCY NAME & ADDRESS (if different from Controlling Office)	15. SECURITY CLASS. (of this report) Unclassified	15a. DECLASSIFICATION DOWNGRADING SCHEDULE	
16. DISTRIBUTION STATEMENT (of this Report) Approved for public release, distribution unlimited.			
17. DISTRIBUTION STATEMENT (of the abstract entered in Block 20, if different from Report)			
18. SUPPLEMENTARY NOTES			
19. KEY WORDS (Continue on reverse side if necessary and identify by block number)			
Human Factors	Simulation	Human Performance	
Human Operator Model	EO Tracking	Manned Threat	
SAM System	TV Tracking	Quantification (MTQ)	
SAM Simulation	Human Operator Tracking		
20. ABSTRACT (Continue on reverse side if necessary and identify by block number)			
A simulation experiment was performed to collect data on the performance characteristics of human operators tracking an aircraft using an electro-optical (TV) tracking system. Two teams were used in the study, each consisting of an azimuth tracker and an elevation tracker. The target aircraft's trajectory was one of five different flight profiles. Performance metrics consisted of angular tracking error in azimuth and elevation. Analysis of variance and Tukey tests were the primary statistical analysis.			

20. Abstract (Cont'd)

techniques. All tracking errors were relatively low but statistical significance was obtained for trajectory differences, team differences, session effects, and team by session interactions. These data will be used to develop models of the human operators to be included in attrition models such as TAC ZINGER. In this way, Air Force researchers and strategists will be able to obtain engagement data, such as miss-distance and P_K , when the threat system is operating in manual modes in addition to the automatic modes currently included in these models.

N

PREFACE

This study was conducted at the Air Force Aerospace Medical Research Laboratory, Wright-Patterson Air Force Base, Ohio. It was one of several studies performed as part of the Manned Threat Quantification (MTQ) program. Subsequent reports will document additional SAM simulation experiments and associated development of human operator models. The SAM system that served as the basis for this study was not identified in terms of the manufacturer. This information can be obtained from Capt. G. Valentino, AFAMRL/HEF.

The author wishes to thank the following individuals for their contributions to this program:

R. Bennett (AFAMRL/HEC)
G. Bothe (SRL)
J. Gardner (SRL)
C. Gulley (SRL)
R. McIntyre (SRL)
Dr. D. Nelson (SRL)
B. Scherzinger (SRL)
Capt. C. Sharper (AFAMRL/HEC)
B. Shumski (SRL)
Capt. G. Valentino (AFAMRL/HEF)
M. Vikmanis (AFAMRL/HEC)
S. Ward (AFAMRL/HEC)
J. Whitmeyer (SRL)
Subject Teams (SRL)

TABLE OF CONTENTS

<u>Section</u>	<u>Page</u>
1 INTRODUCTION	6
2 EXPERIMENTAL PLAN	7
A. FACILITIES AND APPARATUS	7
1. Consoles	7
2. Video	13
3. Plant Dynamics	15
B. INDEPENDENT VARIABLE	15
C. DEPENDENT VARIABLES	15
D. SUBJECTS	20
E. DESIGN	20
F. PROCEDURES	20
3 RESULTS	24
A. VISUAL EXAMINATION OF DATA	24
B. STATISTICAL ANALYSIS OF EXPERIMENTAL EFFECTS	26
1. Analysis of Overall Effects	27
2. Analysis of Trajectory Effects	27
3. Analysis of Session and Replication Effects	27
4. Analysis of Team Effects	34
5. Interaction Effects	34
4 DISCUSSION	35
A. TRAJECTORIES	35
B. TEAMS/SUBJECTS	36
C. SESSIONS/REPLICATIONS	37
D. INTERACTIONS	38

TABLE OF CONTENTS (continued)

<u>Section</u>		<u>Page</u>
5	CONCLUSIONS	39
	A. TRAJECTORIES	39
	B. TEAMS OR SUBJECTS	39
	C. SESSIONS/REPLICATIONS	40
	D. INTERACTIONS	40
	E. GENERAL	40
6	RECOMMENDATIONS	41
APPENDIX A	TRAJECTORY CHARACTERISTICS	42
APPENDIX B	SUBJECT CONSENT FORM	88
APPENDIX C	SAM SIMULATOR DAILY CALIBRATION CHECKLIST	89
APPENDIX D	ENSEMBLE TRACKING ERROR PLOTS	91
APPENDIX E	CELL MEANS AND STANDARD DEVIATIONS	112
APPENDIX F	RESULTS OF TUKEY HSD TESTS	115
APPENDIX G	RMS TRACKING ERROR VS. REPLICATION	118
REFERENCES		124

LIST OF TABLES

<u>Table</u>		<u>Page</u>
1	SIMULATION RESOLUTION	15
2	APPROXIMATE CHARACTERISTICS OF TRAJECTORIES	17
3	EXPERIMENTAL DESIGN - TREATMENTS	22
4	ANOVA FOR RMS AZIMUTH SCORES	28
5	ANOVA FOR RMS ELEVATION SCORES	28
6	ANOVA FOR RMS COMBINED SCORES	28
7	RANK ORDERING OF TRAJECTORIES	39

LIST OF ILLUSTRATIONS

<u>Figure</u>		<u>Page</u>
1	Representative SAM Tracking System	8
2	SAM Simulation Block Diagram	9
3	Elevation Operator's Console	10
4	Azimuth Operator's Console	11
5	TV Display Lines	12
6	Silhouette Background	14
7	Plant Dynamics	16
8	General Representation of Trajectories	18
9	Experimental Design-Sessions	21
10	Average Absolute Combined Tracking Errors, Team 1	25
11	Average Absolute Combined Tracking Errors, Team 4	26
12	Generalized Results of Tukey HSD Tests	29
13	RMS Azimuth Scores Versus Trajectory with HSD Test Results	30
14	RMS Elevation Scores Versus Trajectory with HSD Test Results	31
15	RMS Combined Scores Versus Trajectory with HSD Test Results	32
16	Mean RMS Error Versus Session	33

Section 1
INTRODUCTION

This study was performed in support of the Manned Threat Quantification (MTQ) program at AFAMRL. This program is concerned with modeling the human operator as part of surface-to-air weapon systems. Initial work focused on the human operator as a target tracker for antiaircraft artillery (AAA) systems. This work was extended to surface-to-air missile systems (SAM) in the study documented in this report. Subsequent experimentation will be concerned with the human operator as a decision maker and strategist.

The two main objectives for conducting this study were to:

- (1) Provide a data base for developing a model of the human operator in the manual TV tracking mode of a SAM system.

- (2) Obtain data which would assist in structuring additional MTQ SAM simulation experiments; future experiments will emphasize decision making processes by the human operators.

Section 2
EXPERIMENTAL PLAN

A. FACILITIES AND APPARATUS

The facilities and apparatus for this study were located at the Air Force Aerospace Medical Research Laboratory, Building 33, Wright-Patterson Air Force Base, Ohio. Figures 1 and 2 depict the SAM system and the simulation. The purpose of the simulation was to present to the human operators the TV image and control functions as in a SAM system during a combat engagement. Hence, the target appeared to move like a real aircraft, and the simulated tracking sight appeared to move with the same dynamics as a real sight.

1. Consoles

The consoles used by the elevation and azimuth operators are shown in Figures 3 and 4, respectively. The TV displays presented identical information to both operators via Conrac RQB-14 black and white monitors. These monitors were oriented to produce a vertical scan which is like many SAM system TV displays. Horizontal and vertical lines were present on the displays as shown in Figure 5. The black vertical lines could be used to judge launch boundaries for the missiles by comparing line spacing with the wingspan of the target; this was not part of this study. Subjects were instructed to use the crosshairs as a reference and to keep the target centered at all times.

The "perfect track" switches were used primarily during training to bypass the inputs from the tracking operator's crank and keep the target centered for that axis. This helped subjects to reacquire the target if it left the field of view. These switches were also used during daily calibrations. The "breaklock/reacquire" switch was used to put a signal onto the data tape so that subjects could indicate when the target had left the field of view and if they had reacquired the target. The "run/stop" switch was used to initiate the training and data sessions or to stop a session prematurely, if needed. "Breaklock/reacquire" and "run/stop" switches were not present on

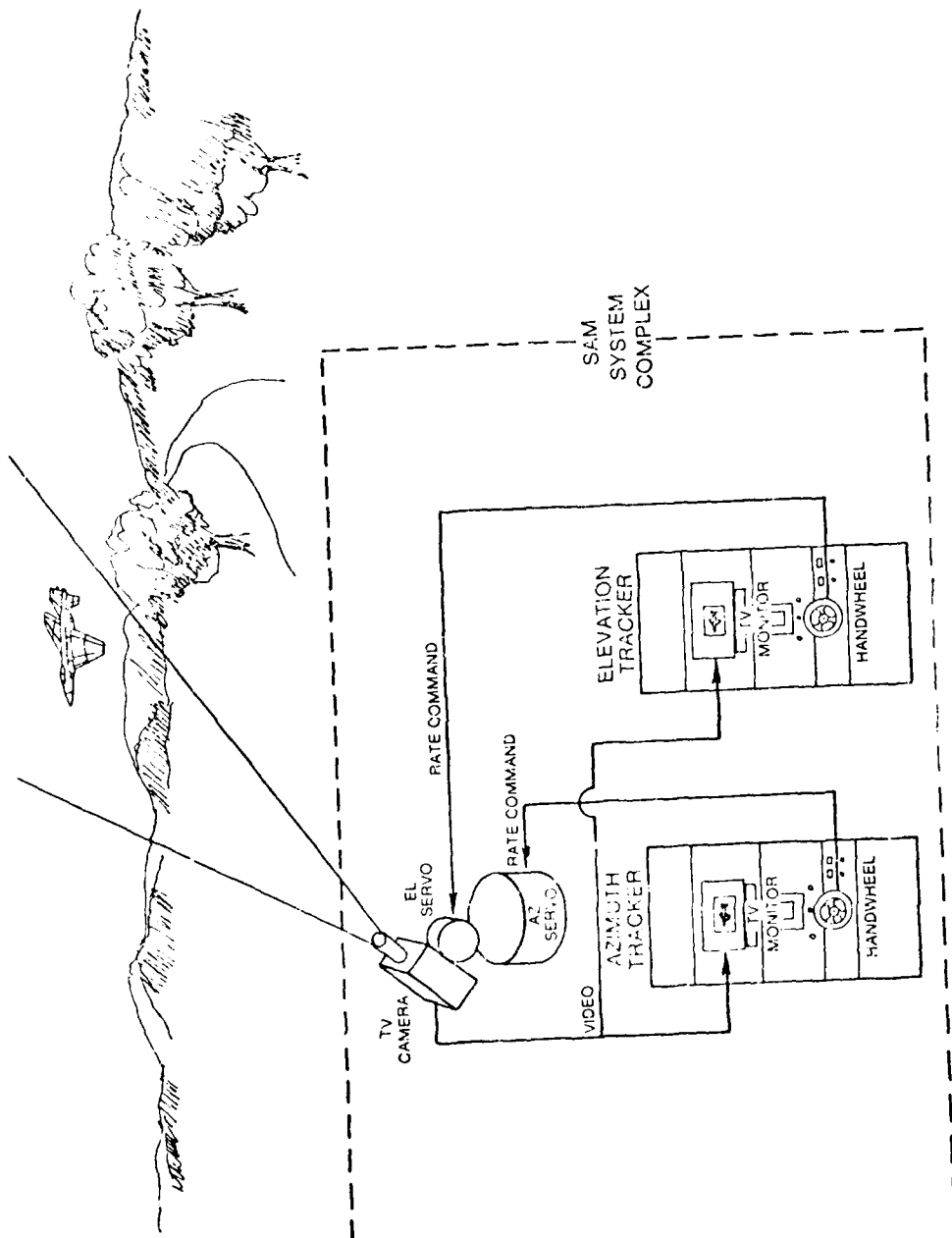

Figure 1. Representative SAM Tracking System

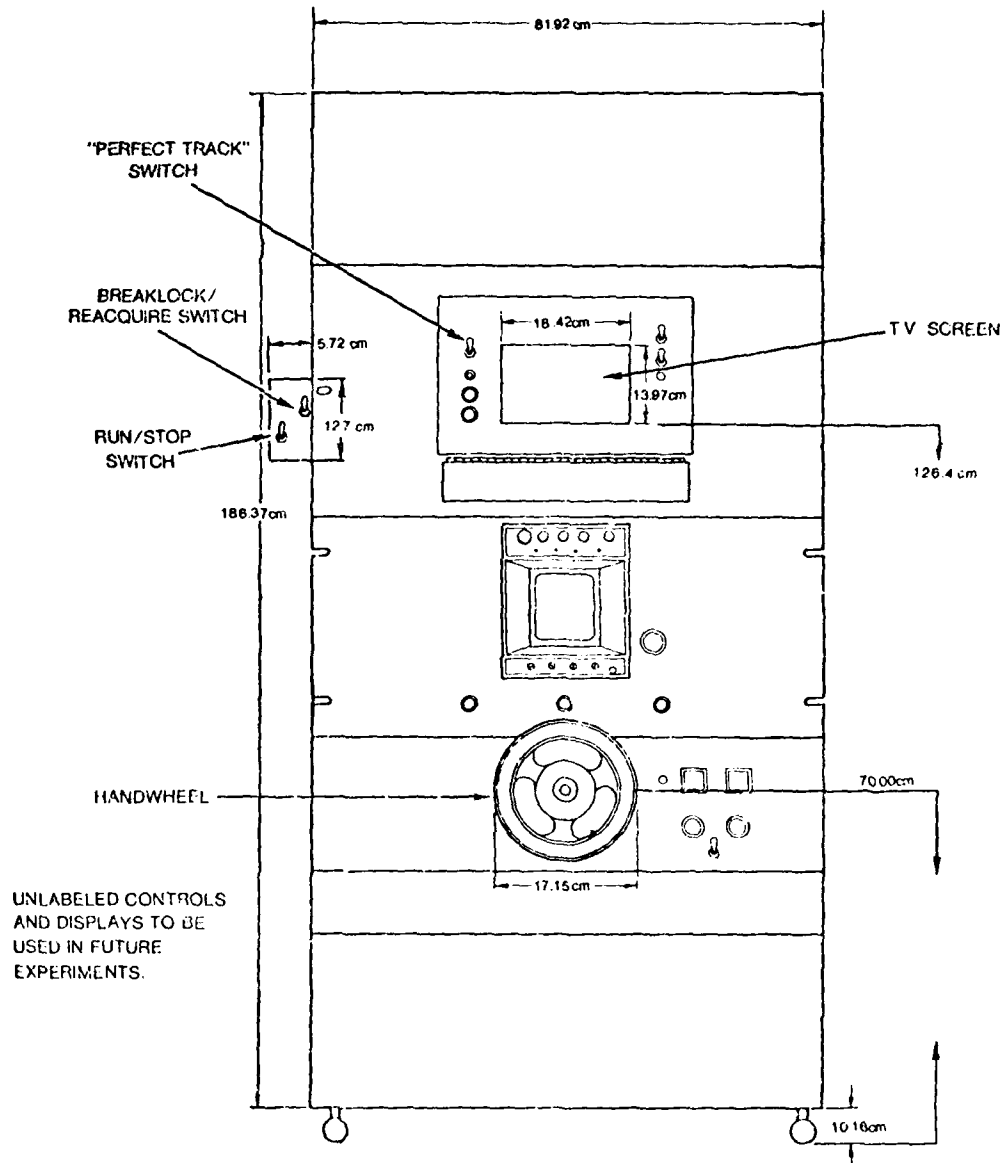

Figure 3. Elevation Operator's Console

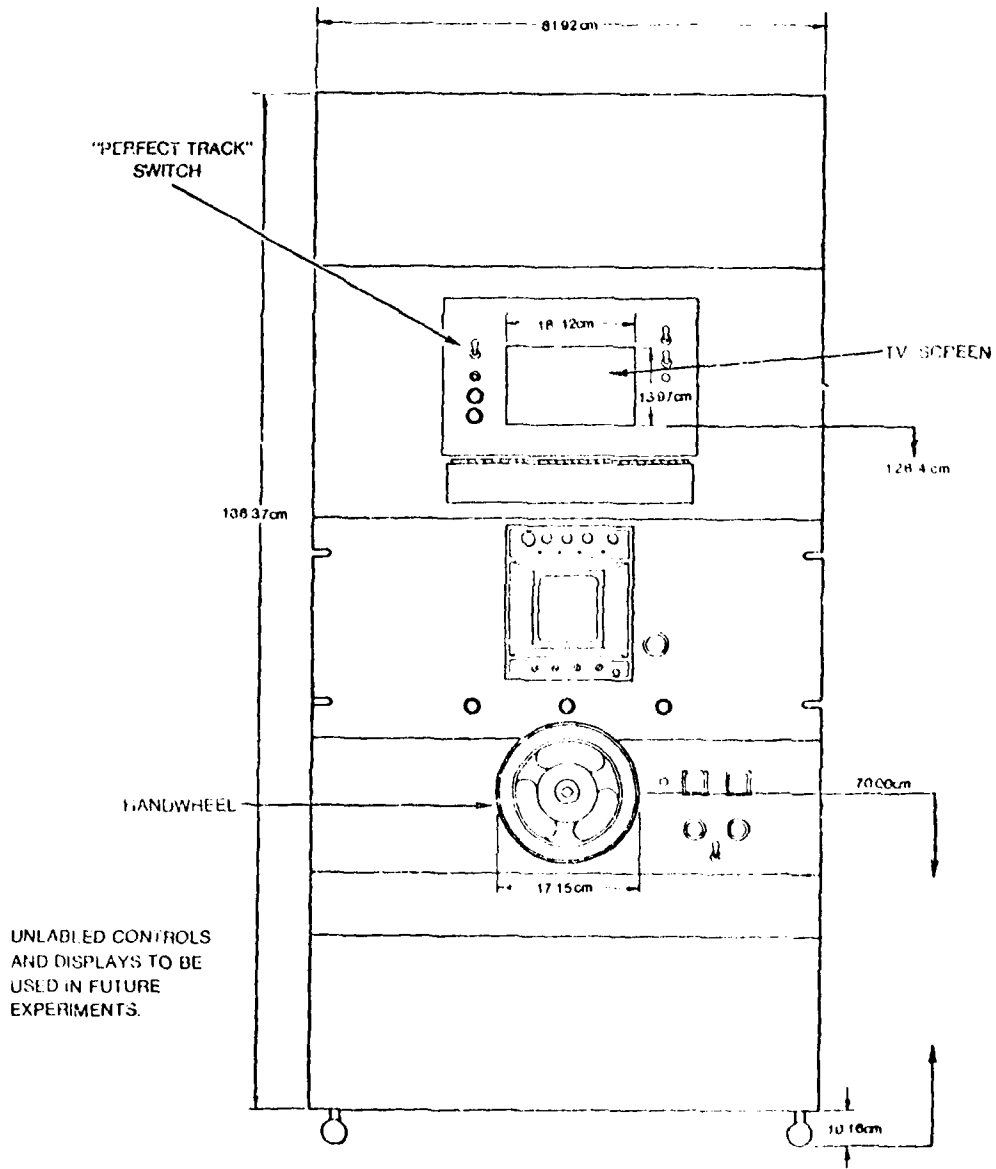

Figure 4. Azimuth Operator's Console

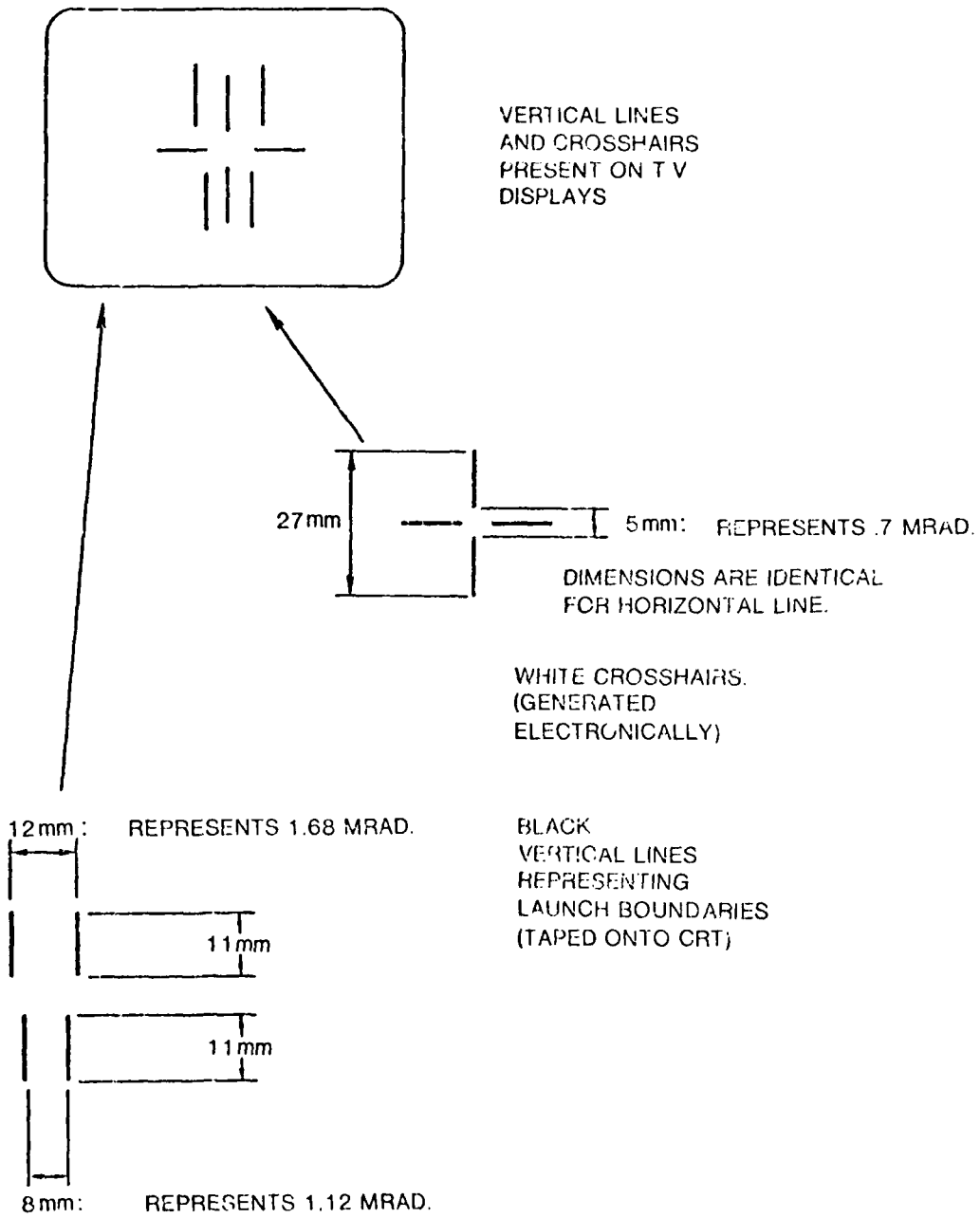

Figure 5. TV Display Lines

the elevation operator's console since a need for duplicate controls was never demonstrated. The handwheels allowed the trackers to make rate control inputs in order to keep the target centered for their respective axis, azimuth, or elevation.

2. Video

The video image presented to the trackers was obtained by mixing an aircraft image with a terrain background image. The aircraft image was generated by having a TV camera view a scale model of an F-4 aircraft that was moved in roll, pitch, and yaw by computer command so that the aircraft's orientation appeared the same way it would to the trackers in a real SAM system. Tracking error between the aircraft and the boresight was used to generate commands for the deflection circuits of the TV camera so that the target appeared to move up/down and left/right. The size of the aircraft image was determined by the model size, path length between the model and camera, and the camera's zoom lens. The computer used the target's slant range, contained on the trajectory disc, to control the zoom lens. The size of the aircraft image equalled the apparent size of the aircraft as a function of slant range when viewed through 10X optics. For example, at a simulated slant range at 4 km, the wingspan of the target would be 2.5 cm wide which is equivalent to 4 mrad. The field of view observed by the trackers was 1.5 degrees in azimuth and 1.0 degree in elevation. The aircraft image was darker than the background. The background was generated by having another camera view a silhouette (see Figure 6) which was drawn onto the acetate film. This film moved in left/right and up/down motions under computer control so that the TV image appeared to move just as it would when the SAM system's TV camera was moved in azimuth and elevation. Although the background did not look like a real terrain scene, previous research (Crabtree and Nelson, 1979) indicated that it would have no adverse affect on tracking performance for the target elevation angles and atmospheric conditions used here.

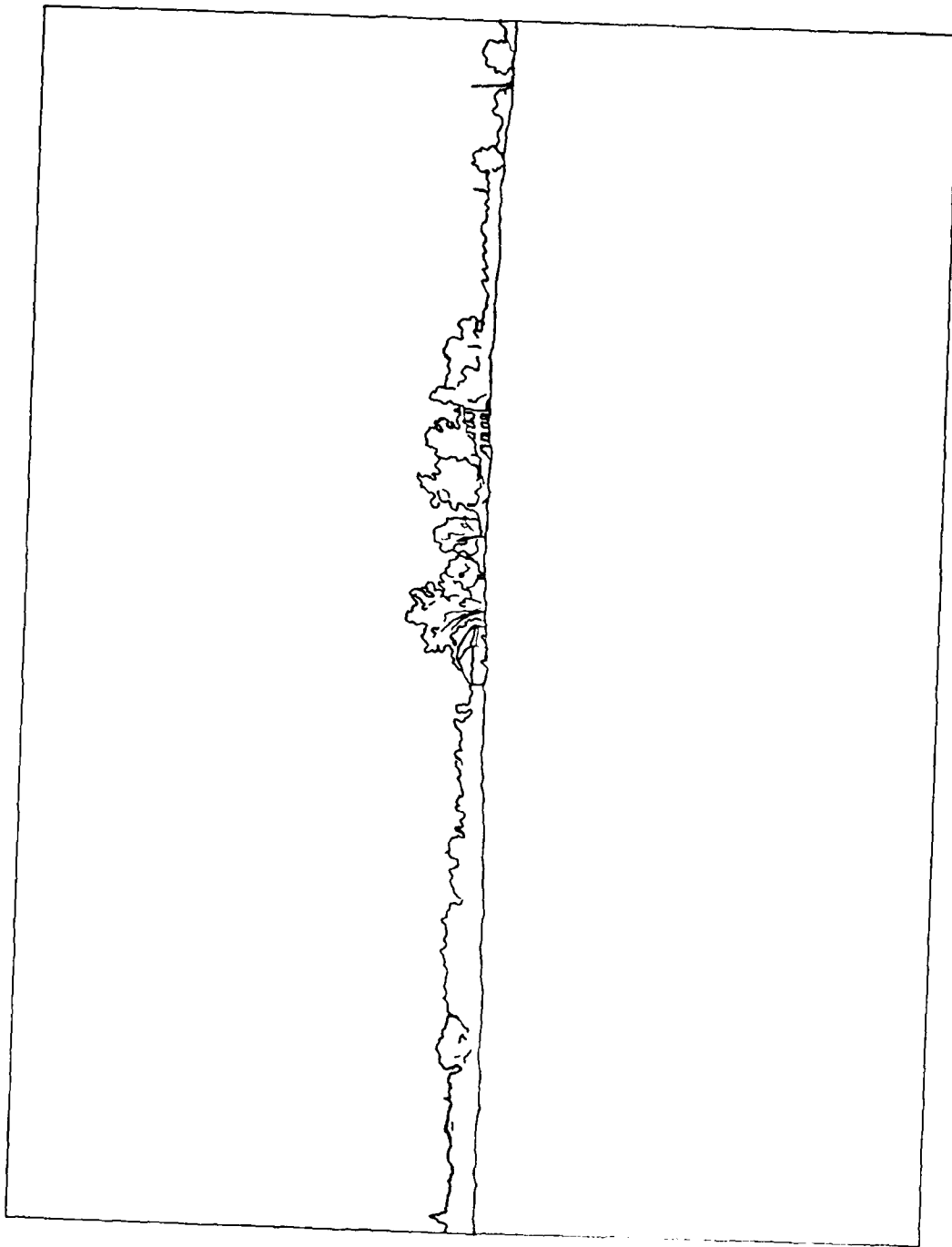

Figure 6. Silhouette Background

3. Plant Dynamics

The plant dynamics for the control system are shown in Figure 7, and the resolution for the simulation is documented in Table 1. The differences in resolution between azimuth and elevation were due to the fixed number of "bits of resolution" which was used to scale a large dynamic range in azimuth but a small range in elevation.

TABLE 1. SIMULATION RESOLUTION

Resolution Parameter	Axis	
	Azimuth	Elevation
Target Position	.0959 mrad	.0256 mrad
Boresight Position	.1 mrad	.0417 mrad
"Data to Tape"	.00129 mrad	.00129 mrad
Total	.19719 mrad	.06859 mrad

B. INDEPENDENT VARIABLE

The independent variable in this study was "trajectory." In order to sample the human operator's performance, it was decided to select various target trajectories which were thought to affect the tracker's behavior. These trajectories are listed in Table 2 and depicted graphically in Figure 8 and Appendix A. Trajectories 1, 2, and 5 were selected to provide a range of azimuth rates from low to high. High was defined as a value which approximated the maximum steady state rate of the servo. Trajectories 3 and 4 were used to investigate the effects of nonlinear trajectories.

C. DEPENDENT VARIABLES

The dependent variables were (1) azimuth error, (2) elevation error, and (3) combined angular error. The first two were defined as the angular difference, in azimuth or elevation, respectively, between the target and the

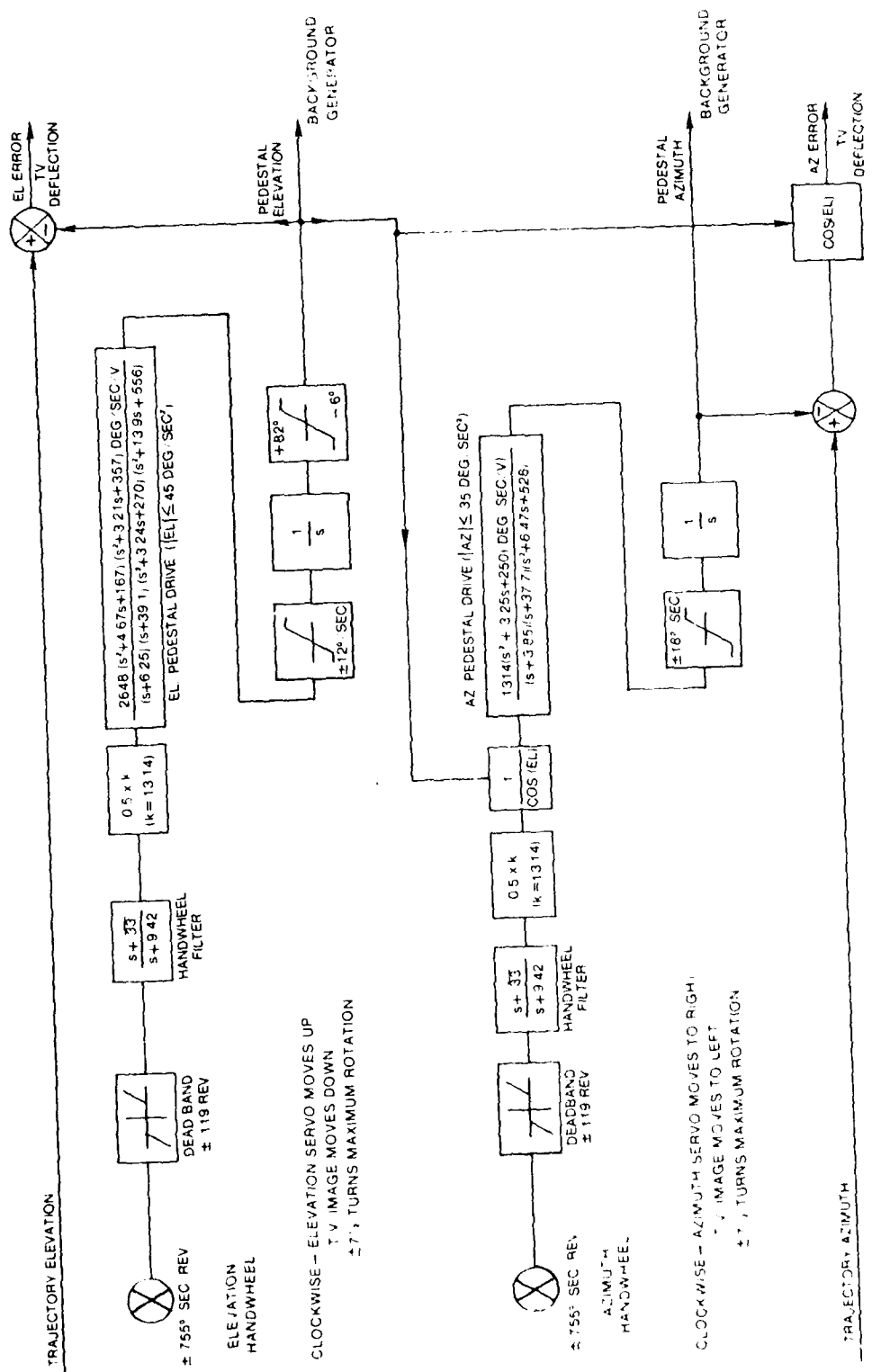

Figure 7. Plant Dynamics

TABLE 1. APPROXIMATE CHARACTERISTICS OF TRAJECTORIES

No.	Name	Trajectory Type	Duration (sec)	Start			Max. in Ratio			Altitude	Rationale	
				AZ (deg)	EL (deg)	Slant Range (km)	Point of Closest Approach (km)	AZ (deg/sec)	EL (deg/sec)			Velocity (m/sec)
1	FLYBY 1B	Straight & Level Flyby	150	83	3.6	24	3	4	.1	210	1.5 km	High altitude
2	SLOW 5A	Straight & Level Flyby	235	33	1.2	24	19.8	.22	.71	75	50 m	Low altitude
3	ER 5-215C	Maneuvering	98	1+2	15	23	8	2.5	1.2	230	varies	variation in range
4	ER 21-2AG	Maneuvering	145	42	4	23	5	>1	>1	120	varies	altitude oscillations
5	FLYBY 1D	Straight & Level Flyby	72	74	2	25	7	5.5	0.5	750	1 km	conservative altitude rate

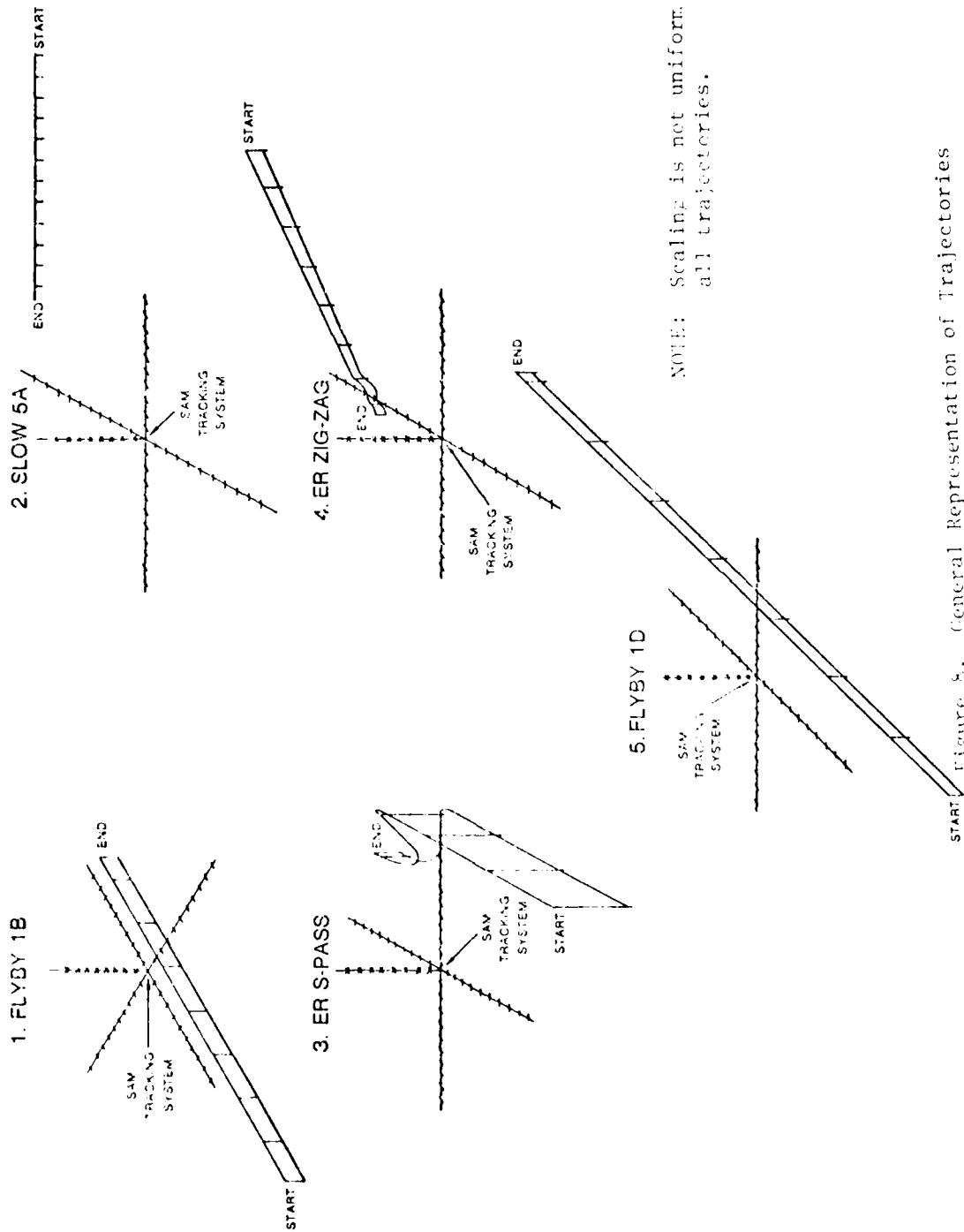

Figure 8. General Representation of Trajectories

boresight of the simulated TV tracker. Combined angular error was obtained by using the formula:

$$\text{Combined Angular Error} = \sqrt{(\text{azimuth error})^2 + (\text{elevation error})^2}$$

Each of the metrics was computed every 25 msec during data collection, and the data recorded on magnetic tape.

The dependent variables (azimuth, elevation, and combined tracking errors) were selected on the basis of providing data about the human operator's individual and team performance. The azimuth and elevation tracking errors are useful for development of the human operator models, and the combined tracking error is a useful metric of total tracking performance. It relates how well the boresight was kept on the target, independent of individual axis error. For a more complete view of system performance, these tracking errors must be entered into an attrition model such as TAC ZINGER so that one can determine missile miss distance and P_K . The angular error provides only limited information since it does not consider slant range, missile trajectory, missile warhead characteristics, or any other factors normally included in an engagement analysis.

Summary statistics, for data analysis, were computed for the above metrics and consisted of RMS error as shown below:

$$\left(\sqrt{\frac{1}{N} \sum_{i=1}^N e_i^2} \right)$$

This was calculated for azimuth error, elevation error, and combined angular error. These statistics were selected since they have been shown to be reasonably reliable and sensitive measures of human operator performance in previous studies.

D. SUBJECTS

Subjects consisted of male and female college students in the 18 to 22 age group. Their vision was 20-20 or corrected to that value. Subjects had previous experience with tracking simulators including the one used in this study.

Only two teams, Team Number 1 and Team Number 4, were selected from the pool of available subjects because of the needs of the modeling effort. The models typically require a high number of replications in order to obtain a stable variance estimate but do not incorporate large numbers of subjects. Prior to participation in the experiment, subjects were required to complete a consent form (see Appendix B).

E. DESIGN

The plan for the training sessions, data collection sessions, and ordering of treatments (trajectories) is documented in Figure 9 and Table 3. Ordering of the treatments was done with an awareness for (1) subjects' ability to "guess" the treatment and (2) sequence effects. However, within a few seconds after the onset of the trajectory, subjects knew which trajectory was being administered. Session length was limited to approximately three quarters of an hour in an attempt to reduce boredom and fatigue for the subjects.

F. PROCEDURES

During training, subjects were instructed to minimize the error between the target and the crosshairs for their respective axis by using their handwheel. To help the subjects assess how well they were tracking, a feedback score was computed and displayed on an auxiliary CRT after each trajectory was

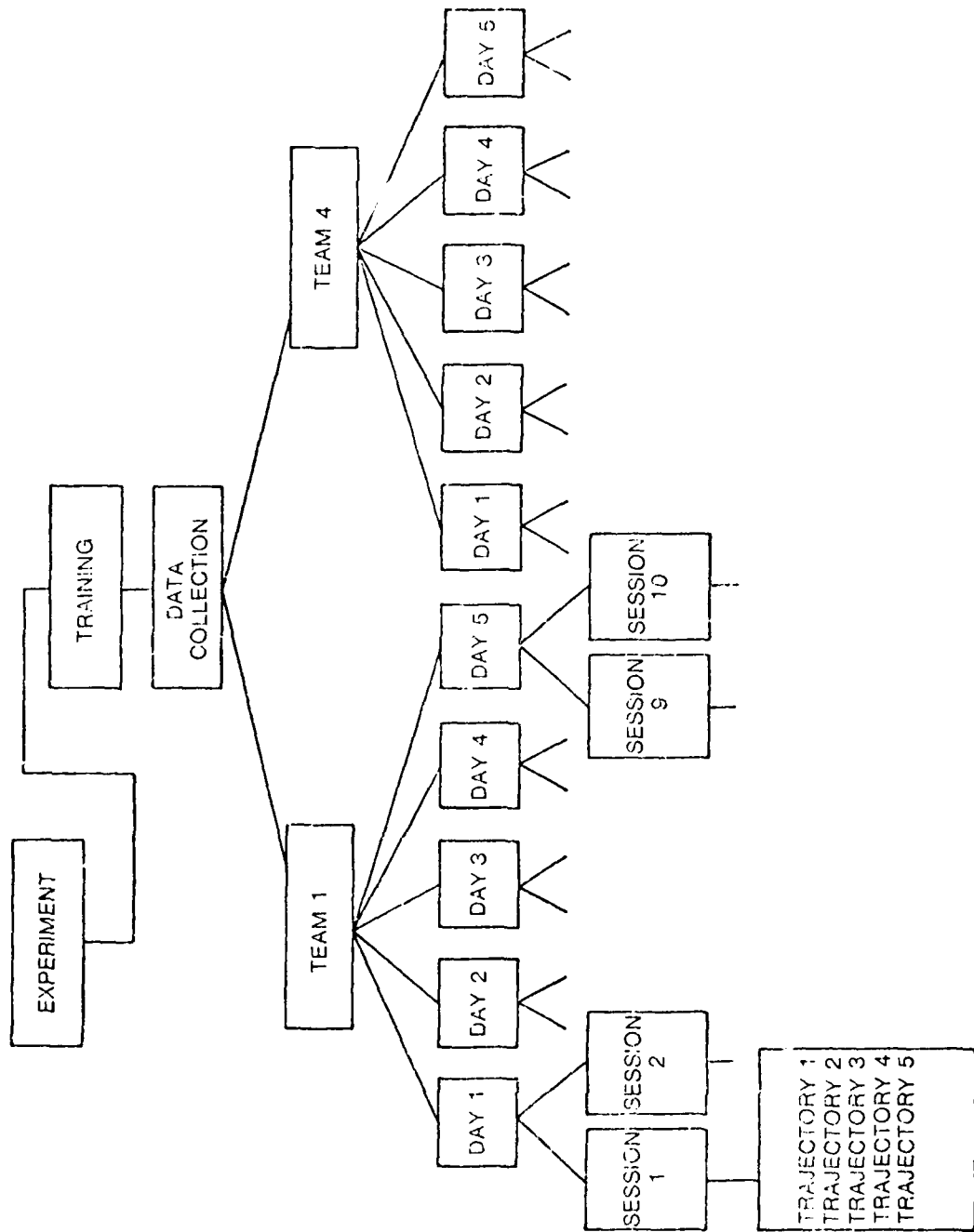

Figure 9. Experimental Design Sessions

TABLE 3. EXPERIMENTAL DESIGN - TREATMENTS

Session	Replication	Sequence of Trajectories				
1	1	5	4	2	1	3
	2	3	4	1	5	2
	3	4	5	2	3	1
	4	3	1	5	2	4
2	5	3	4	2	5	1
	6	1	5	4	3	2
	7	4	1	5	3	2
	8	3	2	4	1	5
3	9	1	4	5	2	3
	10	3	5	2	1	4
	11	2	4	1	3	5
	12	5	1	2	4	3
4	13	2	3	5	4	1
	14	5	1	3	4	2
	15	2	4	1	3	5
	16	1	2	4	5	3
5	17	3	2	5	4	1
	18	2	5	4	3	1
	19	5	1	2	3	4
	20	3	1	4	5	2
6	21	2	3	1	5	4
	22	4	5	2	3	1
	23	3	1	2	4	5
	24	1	4	5	2	3
7	25	5	2	3	1	4
	26	1	3	4	2	5
	27	3	4	5	1	2
	28	4	5	3	1	2
8	29	1	2	3	4	5
	30	4	5	3	1	2
	31	1	3	2	5	4
	32	5	4	1	2	3
9	33	2	1	3	4	5
	34	4	1	5	2	3
	35	5	2	1	4	3
	36	4	3	2	5	1
10	37	2	1	3	4	5
	38	5	3	4	2	1
	39	4	5	1	3	2
	40	2	3	4	5	1

- 1: FLYBY 1B
- 2: SLOW 5A
- 3: ER S-PASS

- 4: ER ZIG-ZAG
- 5: FLYBY 1D

Note: Team 1 stopped with replication 16, Team 4 stopped with replication 20.

completed. The feedback metric was computed separately for each axis and consisted of computing the average of the absolute angular error

$$\left(\frac{1}{N} \sum_{i=1}^N |e_i| \right)$$

based on a sample rate of 25 msec. The score for that trajectory was then multiplied by 100. Multiplying by 100 was done to avoid having small numbers as a feedback score. Subjects in previous studies indicated that they could relate to a scale such as 0 to 100 better than .00 to 1.00. If a subject had difficulty tracking a target, he could use the perfect track switch to keep the target centered so that the target wouldn't leave the field of view and thus prevent the other subject from tracking in his axis. An average was computed for the combined absolute angular error and was used by the training supervisor and principal investigator to judge when the subjects had reached an acceptable level of performance for all of the trajectories. When this point was reached, data collection began.

Procedures during data collection were essentially the same as those during training. Each day, prior to data collection, calibration procedures were performed to insure that the simulator was operating properly (see Appendix C). Presorted keypunch cards were loaded into the computer according to the experimental design. At the beginning of each session was a calibration trajectory during which subjects were not tracking and the simulator was in "perfect track." This served as another check of system operation. Use of the perfect track switch during data collection was not allowed. Subjects tracked each target trajectory as well as possible, and observed their respective feedback scores at the end of each trial. After 20 trials, the next team began tracking. While a team might have completed two sessions in a given day, there was always a rest period between sessions.

Section 3

RESULTS

Four data collection sessions were completed for Team 1, and five were completed for Team 4. This was equivalent to 16 and 20 replications per trajectory for each team, respectively. Due to hardware reliability problems, the project team agreed to terminate data collection at this point for the following reasons:

- (1) Team performance appeared to be relatively stable and completing the design was not expected to cause a significant change in the tracking error metrics.
- (2) It was impossible to estimate future delays. Additional delays would be serious due to subject availability which would necessitate (a) discarding the current data base and (b) retraining new teams.

Unless otherwise noted, all data analysis considered only the first 4 sessions or 16 replications. Session 5 was deleted for Team 4. Approximation techniques could have been used to estimate missing data for Team 1; however, because of the small number of subjects in the study, this would not have been as advisable as truncating the data from Team 4.

A. VISUAL EXAMINATION OF DATA

Plots of the average absolute combined tracking error scores, used to monitor team performance on a session-by-session basis, are shown in Figures 10 and 11 for Teams 1 and 4, respectively. These plots indicated:

- (1) SLOW 5A trajectory was tracked with the lowest error, ER S-PASS and FLYBY 1D had the highest error, and FLYBY 1B and ER ZIG-ZAG clustered in between.

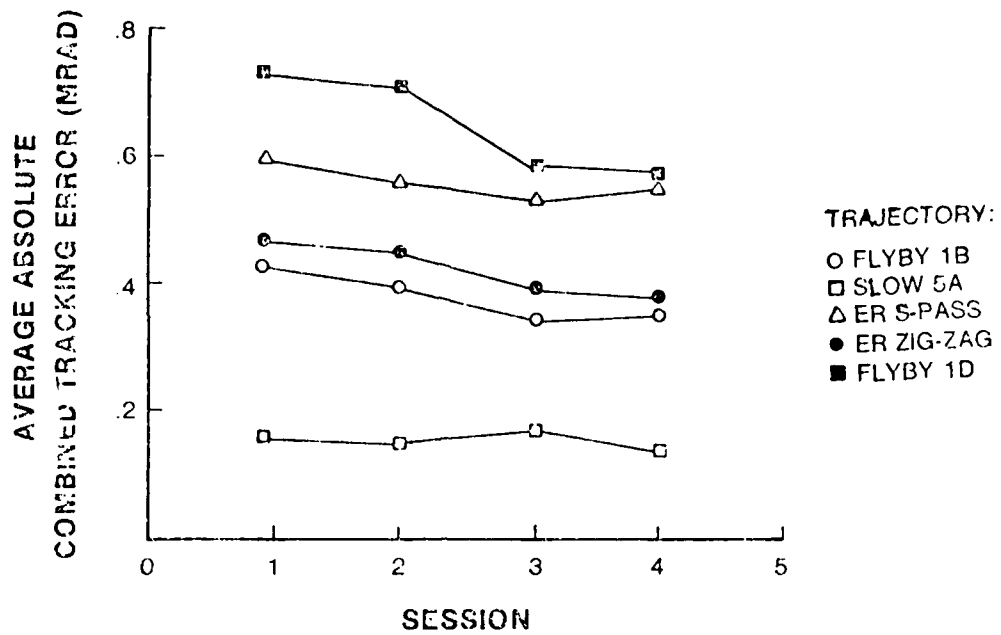

Figure 10. Average Absolute Combined Tracking Errors, Team 1

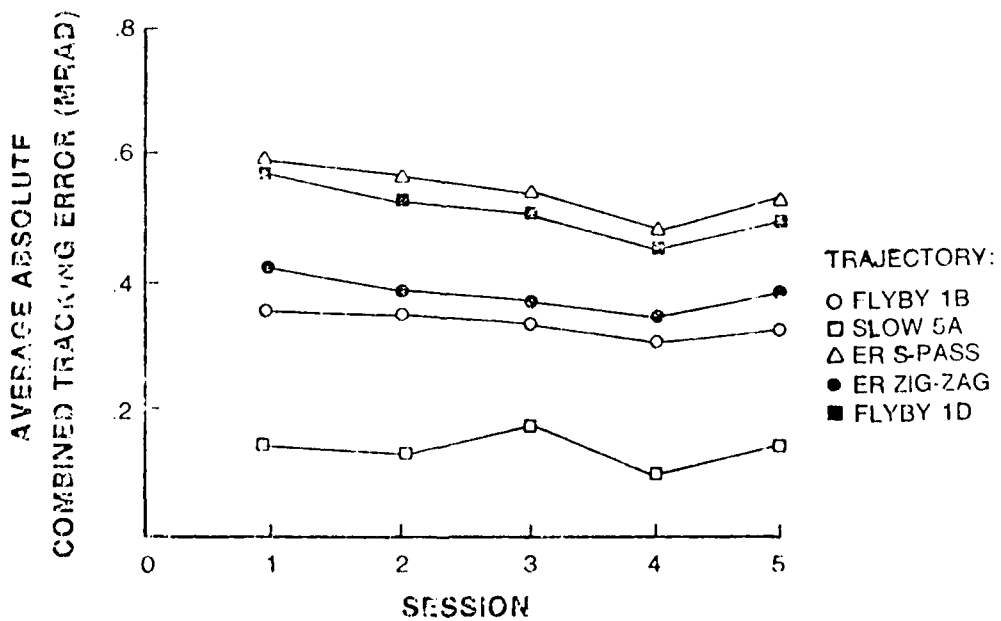

Figure 11. Average Absolute Combined Tracking Errors, Team 4

- (2) Team 4's tracking accuracy was slightly better than Team 1 for FLYBY 1D.
- (3) Tracking errors decreased as a function of replication: FLYBY 1D and ER S-PASS showed the largest change, ER ZIG-ZAG and FLYBY 1B showed moderate change, and SLOW 5A showed the least change.

Plots were generated that show the average tracking error and standard deviation as a function of time for azimuth and elevation for each team (see Appendix D). Note that these plots were based on 16 replications of each experimental condition for Team 1 and 20 replications for Team 4. A visual inspection of these plots indicated:

- (1) Tracking errors were not constant during the trajectory; larger errors were seen in elevation than azimuth in the region around crossover.
- (2) Little difference was observed between teams for mean tracking errors but peaks in standard deviation were higher in azimuth for Team 1 and higher in elevation for Team 4.

B. STATISTICAL ANALYSIS OF EXPERIMENTAL EFFECTS

RMS tracking error scores were computed for azimuth, elevation, and combined errors with only the first 16 replications used for analysis purposes as noted earlier. Examinations of the raw data and questioning the teams indicated that there were no instances where the target left the field of view (breaklocks) and no instances of perfect track switch activations. Examination of the RMS scores for skew and kurtosis indicated that the data were approximately normal, and there was no need for outlier elimination or transformation of the data prior to the statistical analysis.

1. Analysis of Overall Effects

A mixed model analysis of variance (ANOVA) was performed for the RMS azimuth, RMS elevation, and RMS combined tracking scores. The fixed effects were (a) trajectory and (b) session with team as the random effect. The results are presented in Tables 4, 5, and 6. Only the first four sessions were used in this analysis in order to use the same number of replications for each team. This analysis was used to test the hypotheses of no team differences, no trajectory differences, no session differences, and no interactions. Means and standard deviations for each cell in the ANOVAs are presented in Appendix E. Examination of the relationship of the cell means and standard deviations did not indicate any undesirable correlation which would have raised questions concerning the appropriateness of the ANOVA.

2. Analysis of Trajectory Effects

In order to determine which trajectories were responsible for "trajectory" being significant in the ANOVAs, Tukey Honestly Significant Difference (HSD) tests were performed. These tests were applied to all pairs of cell means for trajectories, and the results of these tests are shown in Appendix F. This test consists of comparing the difference between two means with a value based on the Studentized Range statistic (Guenther, 1964; Keppel, 1973; Morrison, 1967).

A general summary of the results from the HSD tests is shown in Figure 12. Results of the HSD tests were combined with plots of RMS tracking error vs. trajectory and are presented in Figures 13, 14, and 15.

3. Analysis of Session and Replication Effects

"Session" was found to be a significant effect in the ANOVAs for the azimuth, elevation, and combined scores. In order to gain some insight into the nature of the session effect, plots of mean RMS error vs. session were prepared (see Figure 16). As can be seen from these plots, tracking errors

TABLE 4. ANOVA FOR RMS AZIMUTH SCORES

Source of Variation	Sum of Squares	Degrees of Freedom	Mean Square	F Ratio
Team	0.508	1	0.508	150.3*
Trajectory	6.777	4	1.694	51.33*
Session	0.069	3	0.023	6.50*
Team X Trajectory	0.133	4	0.033	9.76*
Team X Session	0.016	3	0.005	1.57
Trajectory X Session	0.054	12	0.005	1.57
Team X Trajectory X Session	0.064	12	0.005	1.50
Error	0.356	120	0.003	---

*Significant at the .01 level

TABLE 5. ANOVA FOR RMS ELEVATION SCORES

Source of Variation	Sum of Squares	Degrees of Freedom	Mean Square	F Ratio
Team	0.547	1	0.547	66.25*
Trajectory	4.196	4	1.049	126.61*
Session	0.156	3	0.052	6.37*
Team X Trajectory	0.091	4	0.023	2.86*
Team X Session	0.027	3	0.009	1.05
Trajectory X Session	0.100	12	0.008	1.04
Team X Trajectory X Session	0.046	12	0.004	0.5
Error	0.639	120	0.005	---

*Significant at the .01 level

TABLE 6. ANOVA FOR RMS COMBINED SCORES

Source of Variation	Sum of Squares	Degrees of Freedom	Mean Square	F Ratio
Team	0.011	1	0.011	2.31
Trajectory	10.782	4	2.695	96.25*
Session	0.229	3	0.076	15.96*
Team X Trajectory	0.113	4	0.028	5.88*
Team X Session	0.008	3	0.003	0.62
Trajectory X Session	0.056	12	0.005	1.04
Team X Trajectory X Session	0.079	12	0.007	1.75
Error	0.557	120	0.004	---

*Significant at the .01 level

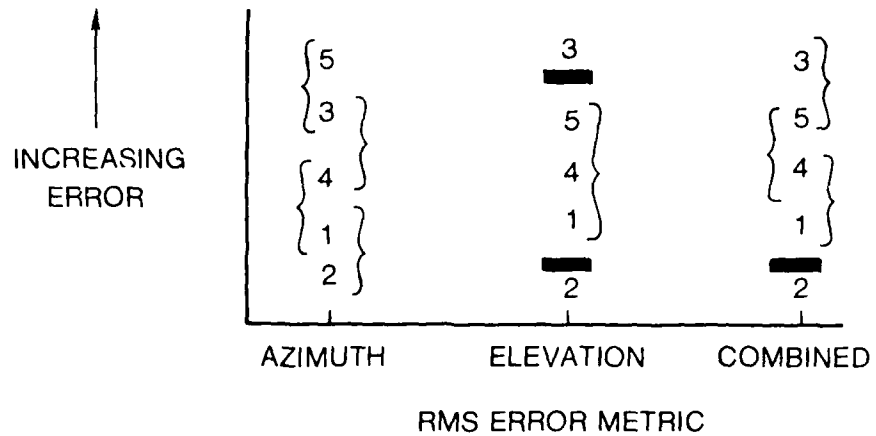

{ : NON-SIGNIFICANT DIFFERENCES

█ : SIGNIFICANT DIFFERENCES FOR ADJACENT ENTRIES

- ENTRIES ARE TRAJECTORY NUMBERS:
1. FLYBY 1B
 2. SLOW 5A
 3. ER S-PASS
 4. ER ZIG-ZAG
 5. FLYBY 1D

Figure 12. Generalized Results of Tukey HSD Tests

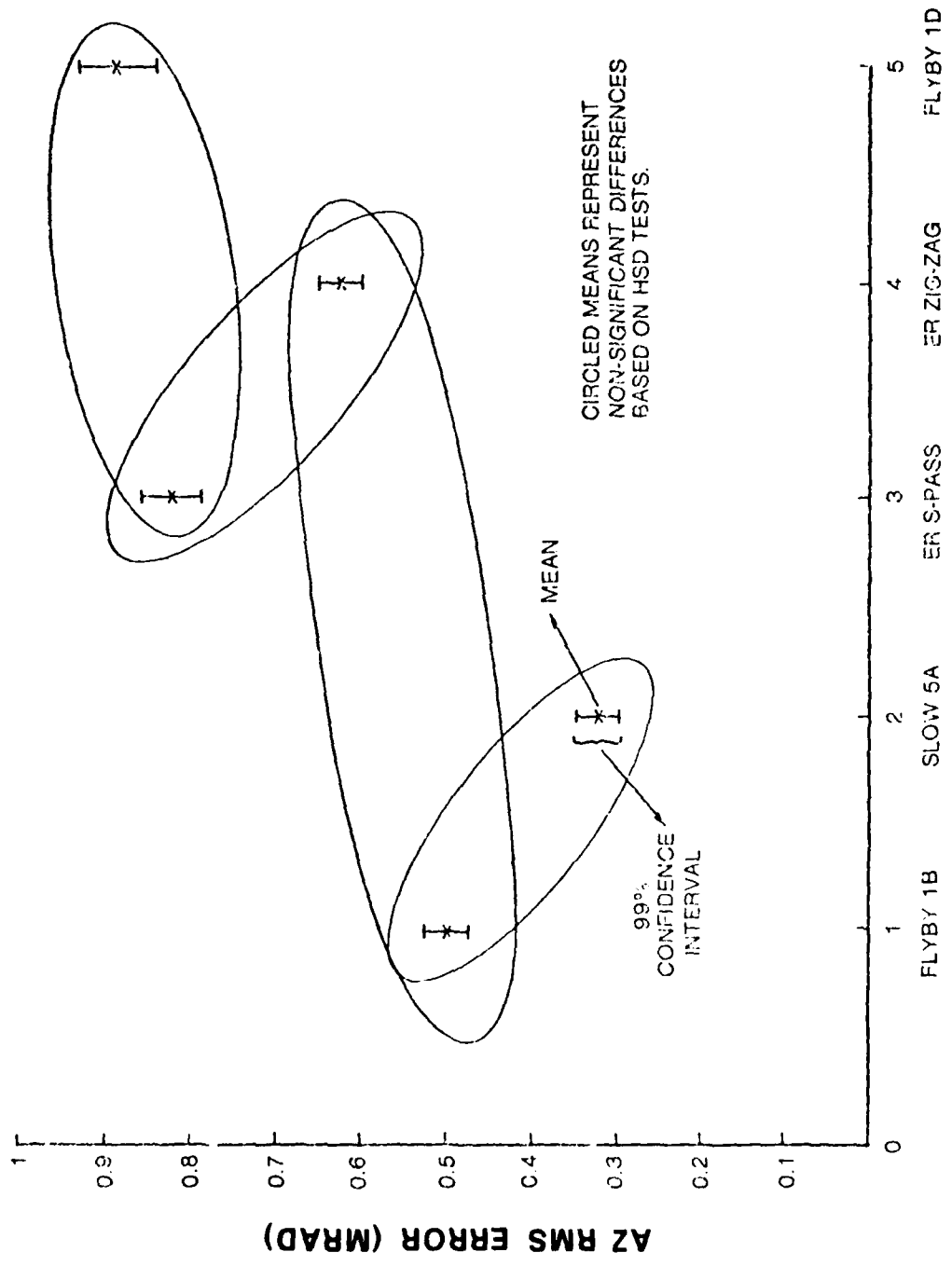

Figure 13. RMS Azimuth Scores Versus Trajectory with HSD Test Results

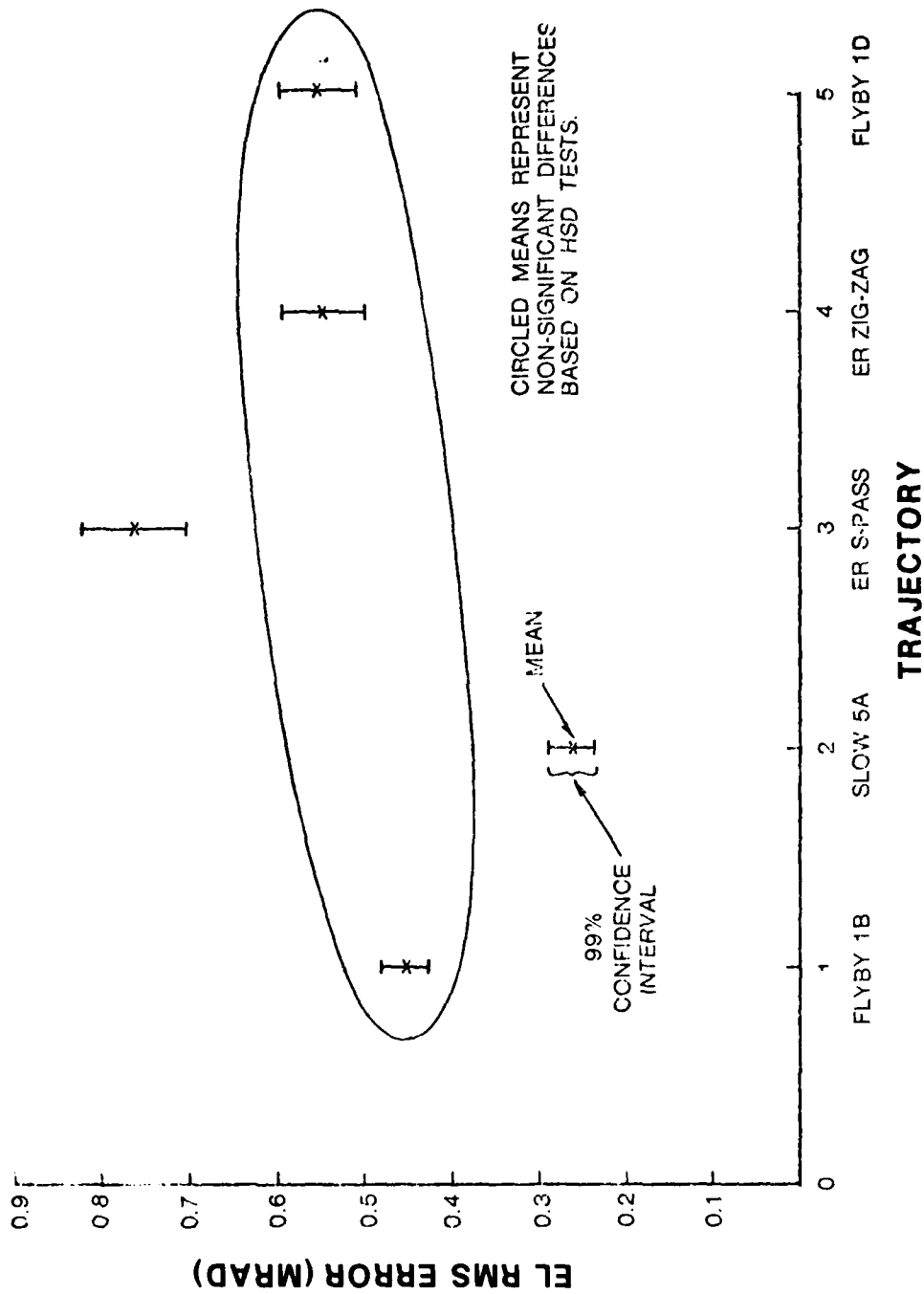

Figure 14. RMS Elevation Scatter Versus Trajectory with HSD Test Results

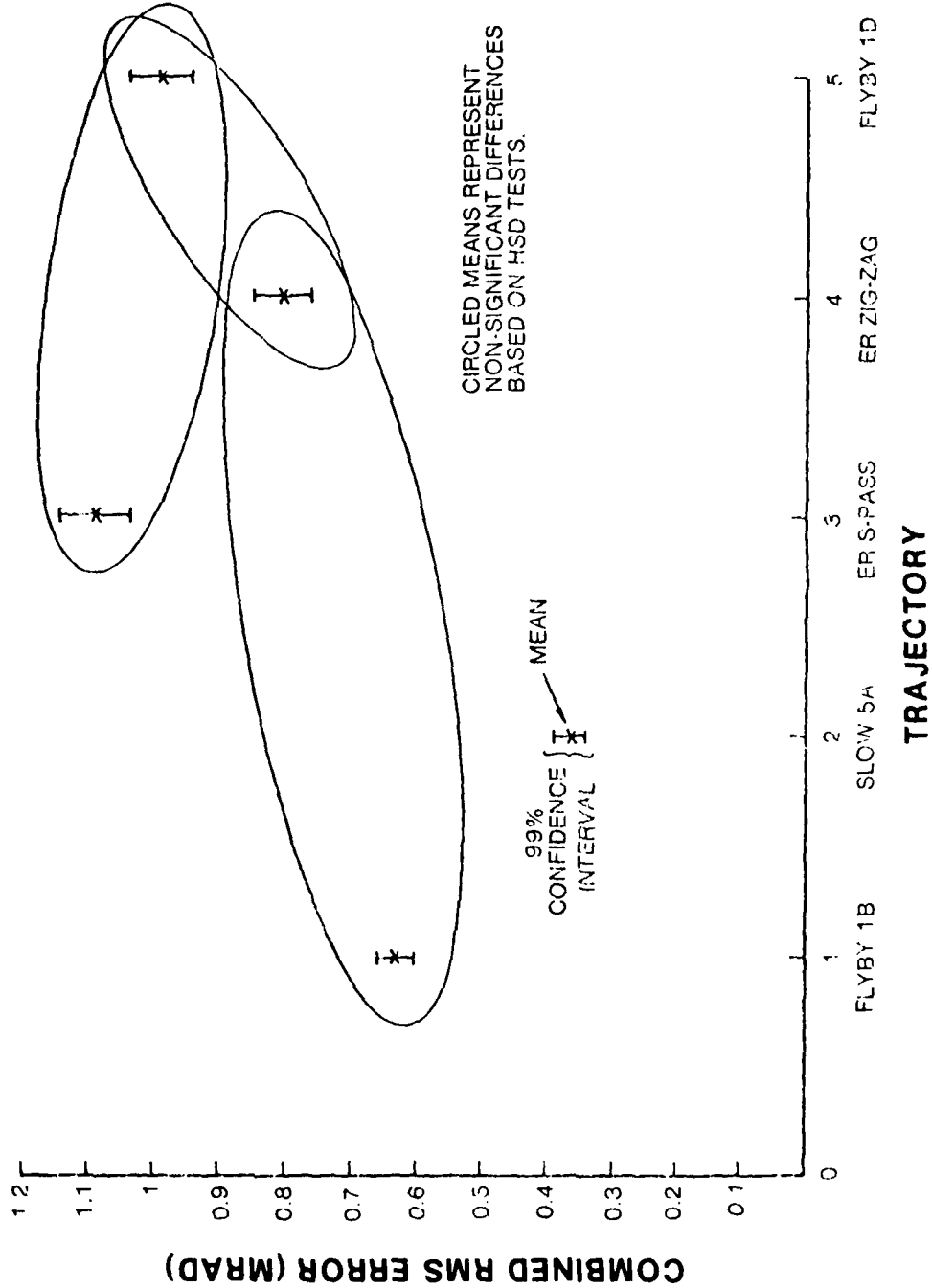

Figure 15. RMS Combined Scores Versus Trajectory with HSD Test Results

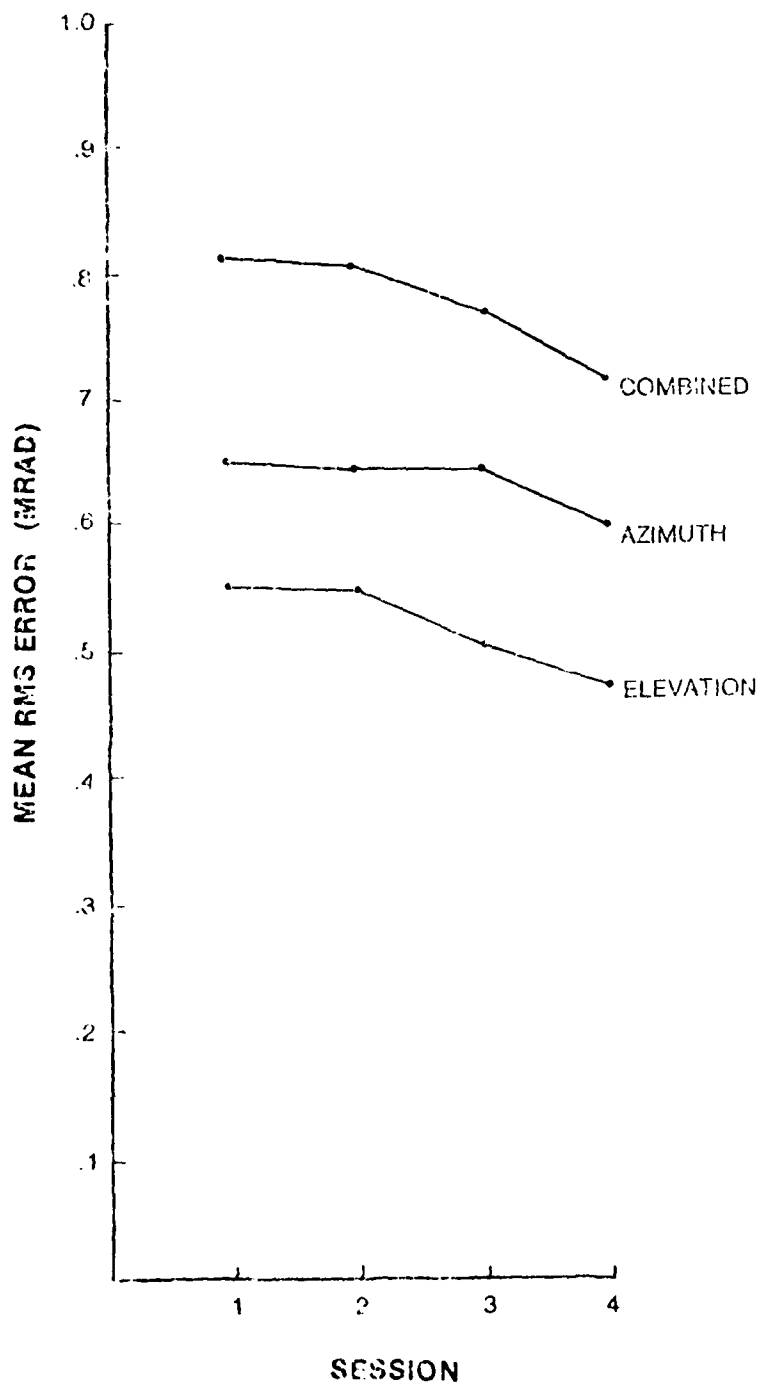

Figure 16. Mean RMS Error Versus Session

decreased for every session with the least change between Sessions 1 and 2. Examination of tracking scores vs. replication, rather than session, gives a more detailed picture of progressive effects (see Appendix G). While the overall trend is more difficult to perceive, it is obvious that the data were not stable over time. Variations were not extremely large, however.

4. Analysis of Team Effects

Team effects were found to be statistically significant for azimuth and elevation scores (Figures 4 and 5) but not for combined scores (Figure 6). Additional results which suggest team differences can be found in Figures 10 and 11 and in Appendices D, E, and G.

5. Interaction Effects

Statistical significance was achieved for the interaction of team and trajectory for the azimuth, elevation, and combined tracking scores (Tables 4, 5, and 6). Further analysis was not warranted, but the issue is treated again in the Discussion section.

Section 4
DISCUSSION

A. TRAJECTORIES

The trajectories used in this study must be considered "familiar" to the subjects due to training, number of replications, and previous experience. While unfamiliar trajectories might have induced higher initial tracking errors, the errors would likely become smaller with more replications. The decrease in RMS error across session, shown in Figure 15, also supports this conclusion. Requirements of the human operator model development, however, created a need for a large number of replications. In spite of attempts to use difficult trajectories, i.e., high angular rates or maneuvering, tracking errors were not extremely high. They were less than 5 mrad maximum as indicated by the ensemble average tracking error plots (Appendix D) with no breaklocks.

The analysis of the summary statistics and examination of tracking errors as a function of time were in agreement for establishing that trajectory effects existed. The ANOVAs for azimuth, elevation, and combined errors indicated that trajectory differences did exist. The Tukey HSD tests substantiated this finding also (reference Figures 13, 14, and 15), but the trajectory differences were not extremely strong. From Figure 12, it can be seen that the trajectories fell into an almost uniform ranking for all three metrics. Further examination, however, indicated that differences between "adjacent" trajectories were not statistically significant except for three instances. This figure bears some resemblance to the trajectory characteristics (Table 2) as noted below:

- (1) Trajectory 2, SLOW 5A, had the lowest scores; and this trajectory could be considered the easiest since it was a flyby with low angular rates for both axes.

- (2) Trajectory 1, FLYBY 1B, would be expected to have higher azimuth tracking errors due to the higher angular rate in this axis. It is unusual that there were significant differences between Trajectories 1 and 2 for elevation but not for azimuth. This could be due to the differences between individual operators (see "B. TEAMS/SUBJECTS" below).
- (3) Trajectory 4, ER ZIG-ZAG, could be expected to yield higher azimuth tracking errors since the trajectory is not as predictable as the flybys, Trajectories 1 and 2. Azimuth scores for trajectories fell into an ordinal relationship of 1, 4, and 3; but elevation scores fell into one group for these trajectories. This ordinal relationship appears reasonable since it coincides with the "no azimuth perturbations," "slight azimuth oscillations," and "high azimuth rate at egress" characteristics of these trajectories.
- (4) Trajectories 3, ER S-PASS, and 5, FLYBY 1D, are related as such due possibly to the "excessive" azimuth rate of Trajectory 5 and the "elevation maneuver" of Trajectory 3.

Trajectory effects were also observed when visual examinations of ensemble tracking errors vs. trajectory accelerations were made for each respective axis (see Appendices A and D). It was observed that as azimuth or elevation angular acceleration increased, the ensemble tracking error and standard deviation for that axis also increased. This typically occurred at cross-over or during a maneuver. Trajectory 2, SLOW 5A, was an exception which yielded relatively uniform performance over the entire trajectory. Because this trajectory had such low angular rates and the tracking was so stable, it could be considered a baseline for the team's best possible performance.

B. TEAMS/SUBJECTS

It is possible that the data would have fallen into more uniform patterns if the better azimuth operator was paired with the better elevation operator. If this was done, then one team could have been identified as "better"

since the tracking errors would have been lower for both axes. With the subjects used in this study, "the best" team would consist of Team 1's elevation operator and Team 4's azimuth operator. The other subjects would then constitute "the second best" team.

The ensemble average tracking error (Appendix D) were given a visual inspection to see if different strategies might have existed. Only two minor differences were observed:

- (1) For Trajectory 1, FLYBY 1B, Team 1's azimuth error alternated from the negative region to the positive region at crossover, but Team 4's error lacked the negative region.
- (2) For Trajectory 2, SLOW 5A, Team 1's azimuth error was essentially in the positive region while Team 4's was in the negative region.

Team differences were significant for azimuth and elevation scores but not for the combined scores. Team 4 showed lower error scores than Team 1 for azimuth, and the reverse was true for elevation. This reversal between azimuth and elevation errors most likely caused the lack of a significant difference between teams for the combined score. These team differences were also confirmed in the plots of (1) RMS errors vs. replications (Appendix E) and (2) ensemble average tracking errors (Appendix D).

C. SESSIONS/REPLICATIONS

There were several indications that effects due to session existed. Average absolute combined tracking errors (Figures 10 and 11), and Mean RMS Error (Figure 16) indicated slight improvements with each session. Session was found to be statistically significant for azimuth, elevation, and combined RMS errors based on the ANOVAs. Finally, the plots of RMS error scores vs. replication (Appendix G) also showed progressive effects. These effects were relatively small; and if they had been larger, one would have to question the criterion used to determine that the subjects were adequately trained.

D. INTERACTIONS

The ANOVAs indicated a significant interaction between team and trajectory for the azimuth, elevation, and combined scores. The apparent cause for this significant interaction was an increase in disparity between teams for the more difficult trajectories. Examination of means and standard deviations (Appendix E) indicated that as trajectories become more difficult, due to higher angular rates or maneuvering, the difference between teams increased.

Section 5
CONCLUSIONS

A. TRAJECTORIES

Differences among trajectories were observed based on the azimuth, elevation, and combined tracking scores. The trajectories could be grouped in the order shown below:

TABLE 7. RANK ORDERING OF TRAJECTORIES

Tracking Errors	Highest	ER S-PASS, FLYBY 1D
	↑	ER ZIG-ZAG
	↓	FLYBY 1B
	Lowest	SLOW 5A

The tracking errors appeared to be related to the angular accelerations of the trajectories with an increase in mean error and standard deviation as angular acceleration increased.

B. TEAMS OR SUBJECTS

Differences between teams were found for azimuth and elevation tracking scores but not for combined scores.

Team 4 performed better for minimizing azimuth tracking errors; Team 1 performed better for minimizing elevation tracking errors. Ensemble averages of tracking error as a function of time indicated only minor strategy differences between teams.

C. SESSIONS OR REPLICATIONS

Statistically significant differences were obtained for session effects for azimuth, elevation, and combined scores. The magnitude of these effects was small and could be expected to diminish if the full 40 replications had been obtained.

D. INTERACTIONS

There was a statistically significant interaction between team and trajectory factors for azimuth, elevation, and combined scores. The cause for the interaction is believed to be less divergence between teams for the easy trajectories than the difficult trajectories (see Appendix E).

E. GENERAL

Although statistically significant differences were obtained, all tracking errors were relatively small: 1.089 mrad maximum RMS error and 5 mrad *maximum ensemble average error*. Little change would be expected even if the full 40 replications were completed since within replication error was quite small. The impact of these small human operator tracking errors on overall weapon system performance (i.e., miss distance and P_K) will be assessed in future MTQ SAM simulations and analyses. Comparisons will be made between human operator tracking and radar autotrack.

Section 6
RECOMMENDATIONS

Some additional work remains to be done to quantify the characteristics of the human operator for basic, stable tracking performance. Within this context, the following research topics are recommended for subsequent experiments:

- (1) Explore the upper limits of "trajectory difficulty," keeping in mind that "breaklocks" are unlikely to occur when tracking in all manual TV and radar modes.
- (2) Incorporate trajectories with more complex maneuvers to cause variations in azimuth and elevation tracking performance simultaneously.
- (3) Use unfamiliar trajectories with well-trained subjects to determine if a general "good tracker" exists or if numerous replications are needed to become proficient with various types of trajectories.

After basic tracking performance has been established, it is recommended that additional research be directed at experiments involving operator strategy. Specific emphasis should be given to:

- (1) Acquisition and hand-off studies where tracking begins at various slant ranges within the launch envelope.
- (2) Operator strategy in a countermeasure environment.
- (3) Ability of operators to estimate launch envelope by visual size and aspect of the target.

Appendix A
TRAJECTORY CHARACTERISTICS

Note:

- (1) Plots should be considered as approximate information only since they have been smoothed graphically to eliminate noise.
- (2) Sign conventions:

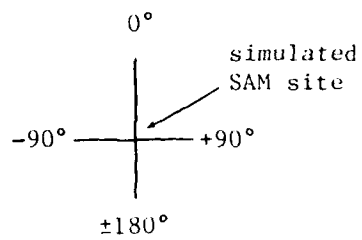

- (3) Note that scaling of axes is not uniform across trajectories.

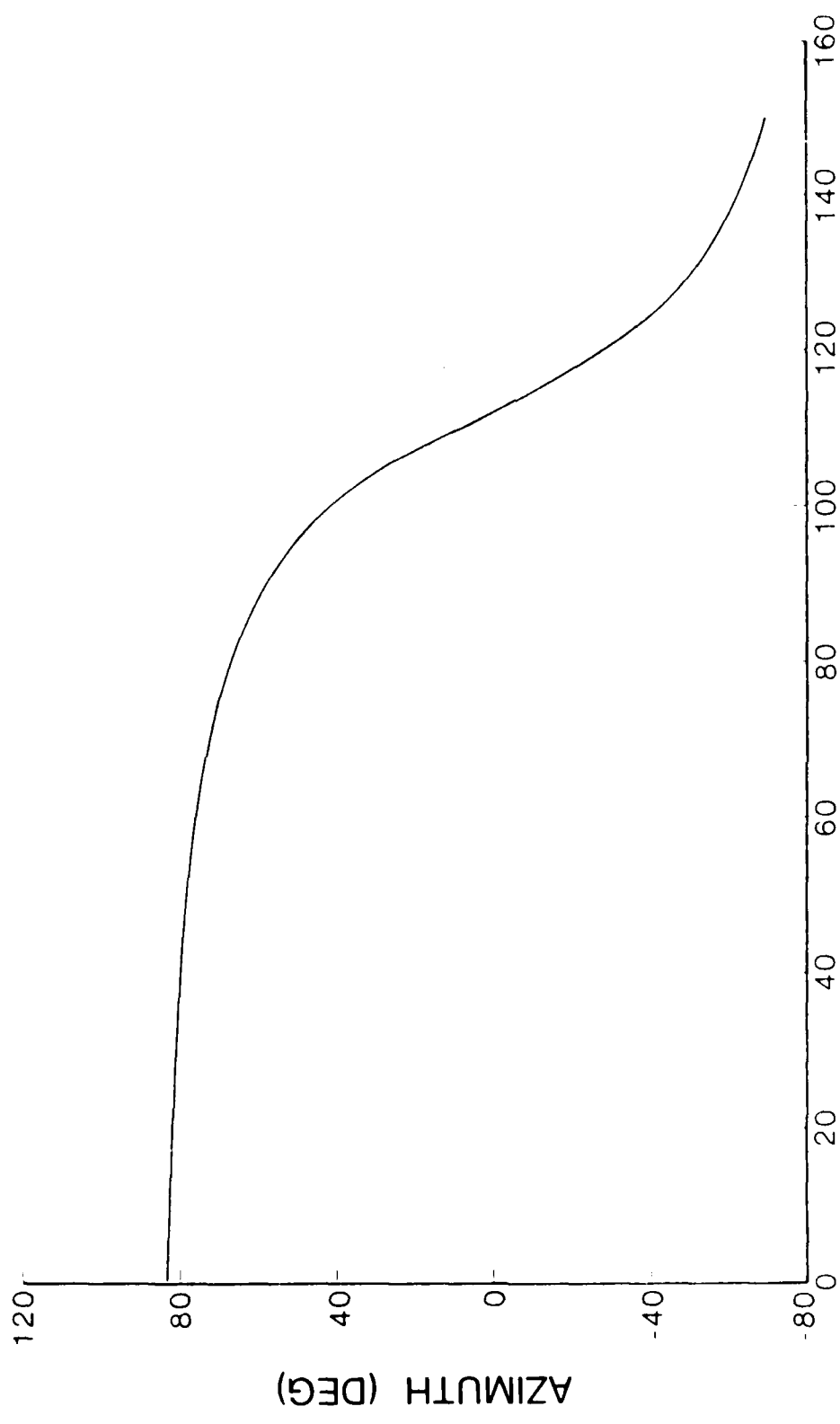

TIME (SEC)

FLYBY 1B

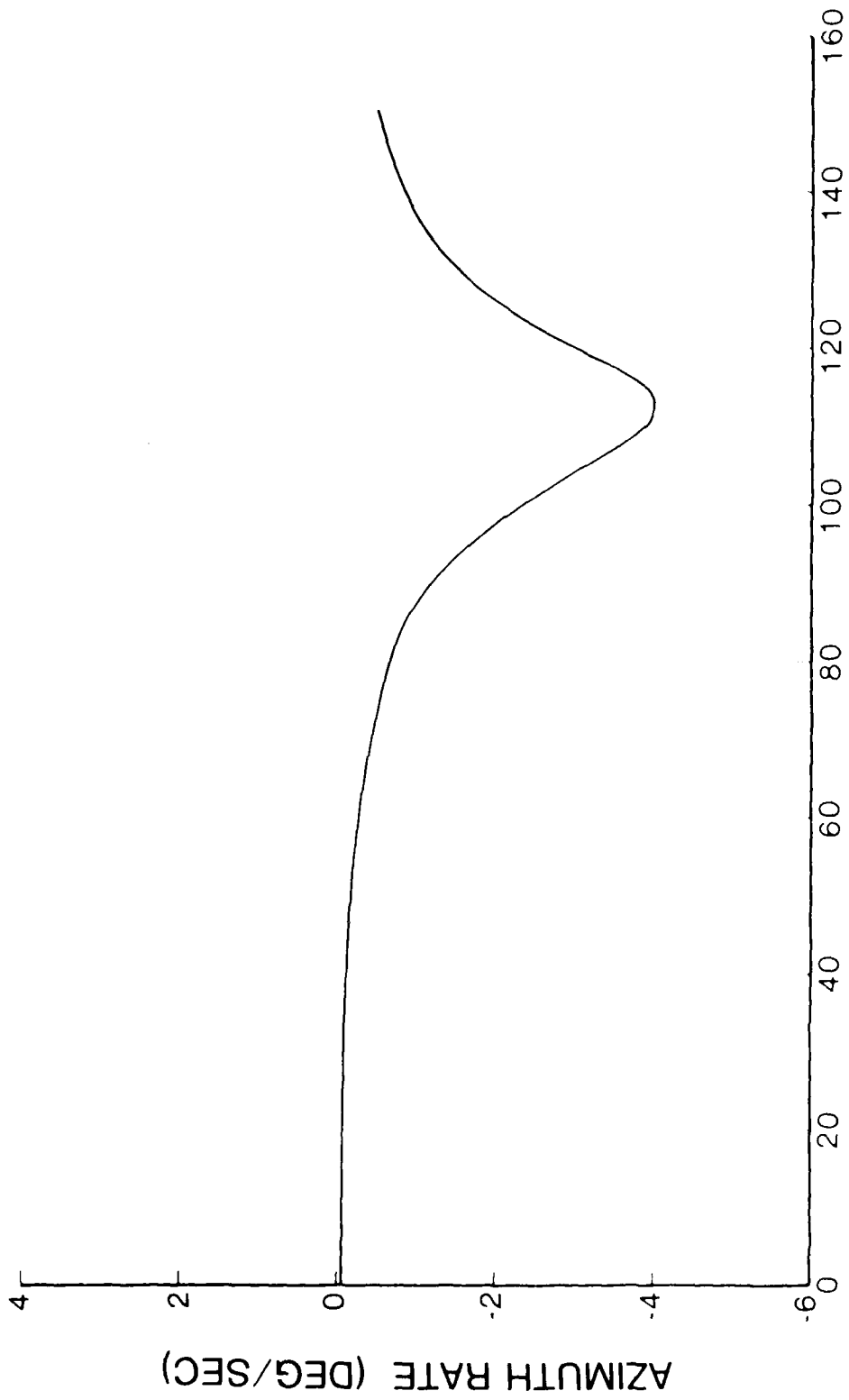

TIME (SEC)

FLYBY 1B

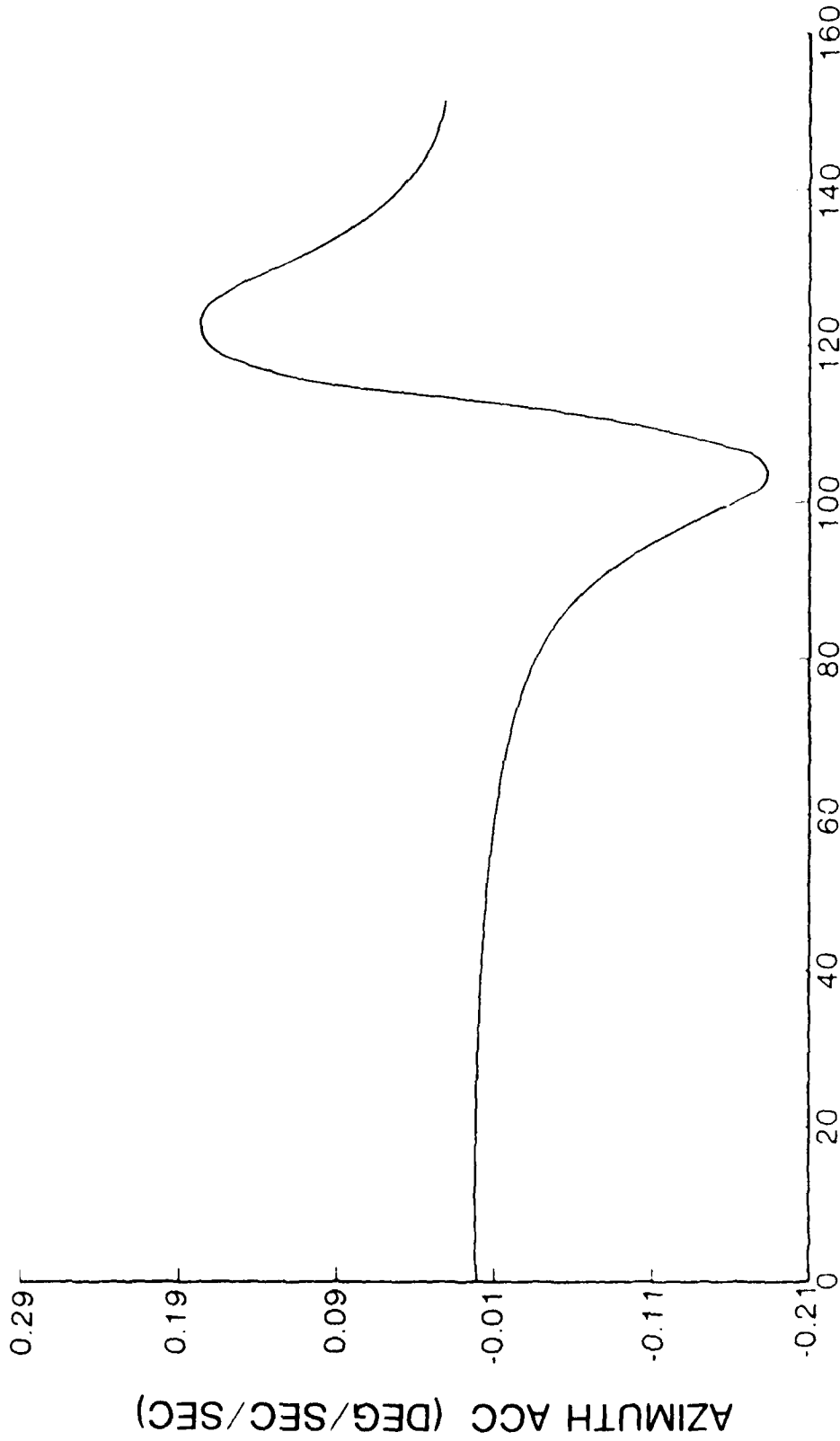

TIME (SEC)

FLYBY 1B

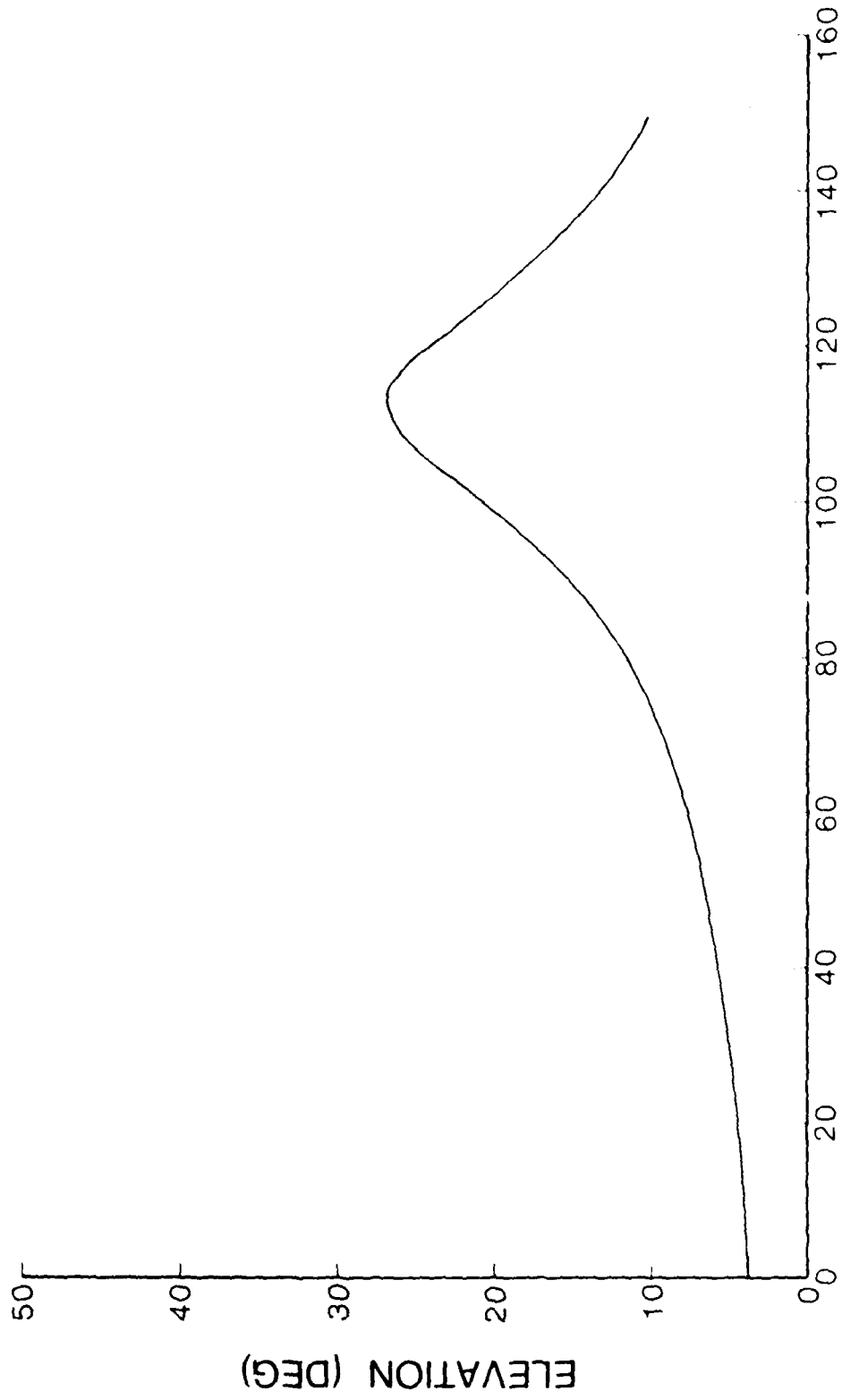

TIME (SEC)

FLYBY 1B

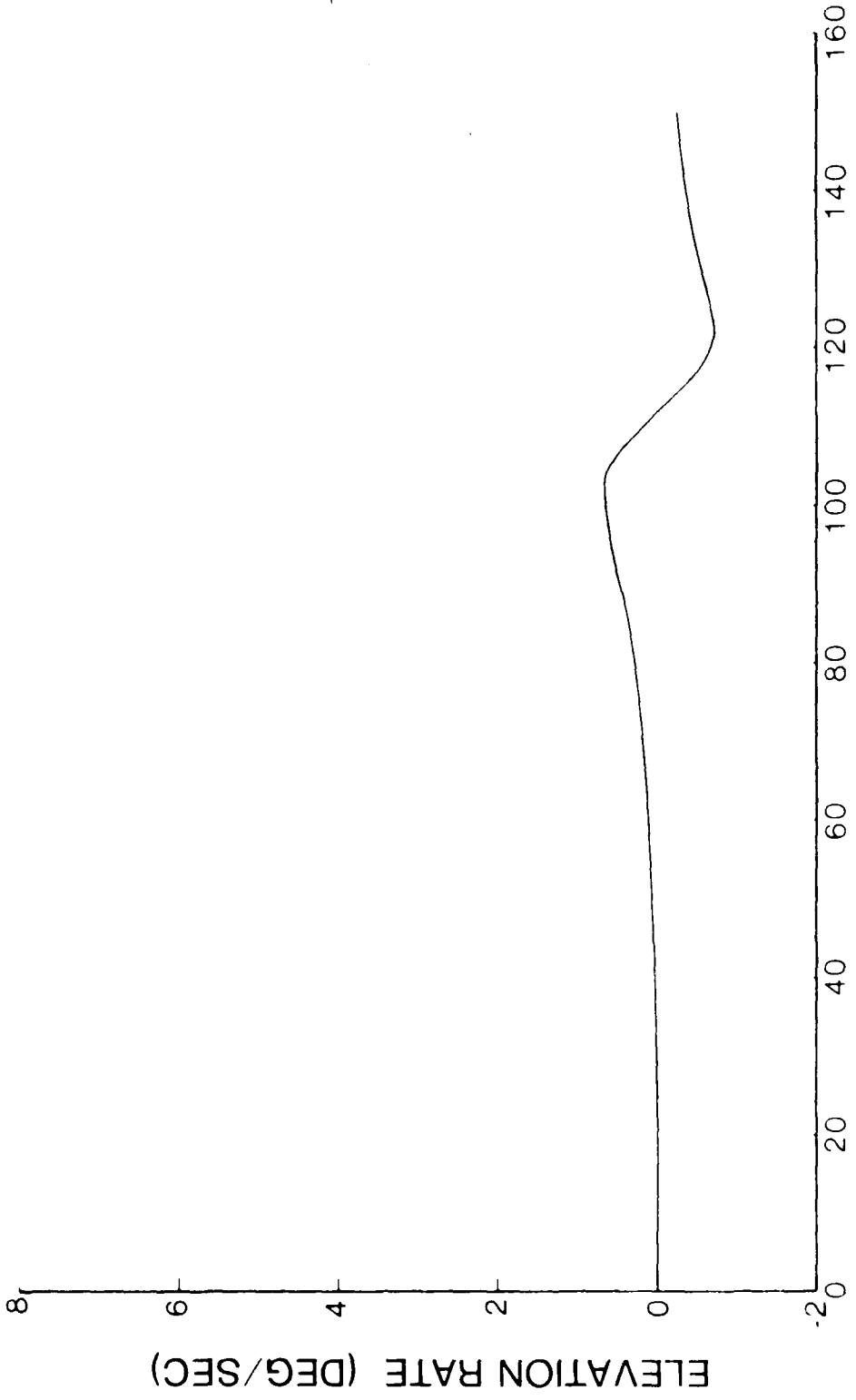

TIME (SEC)
FLYBY 1B

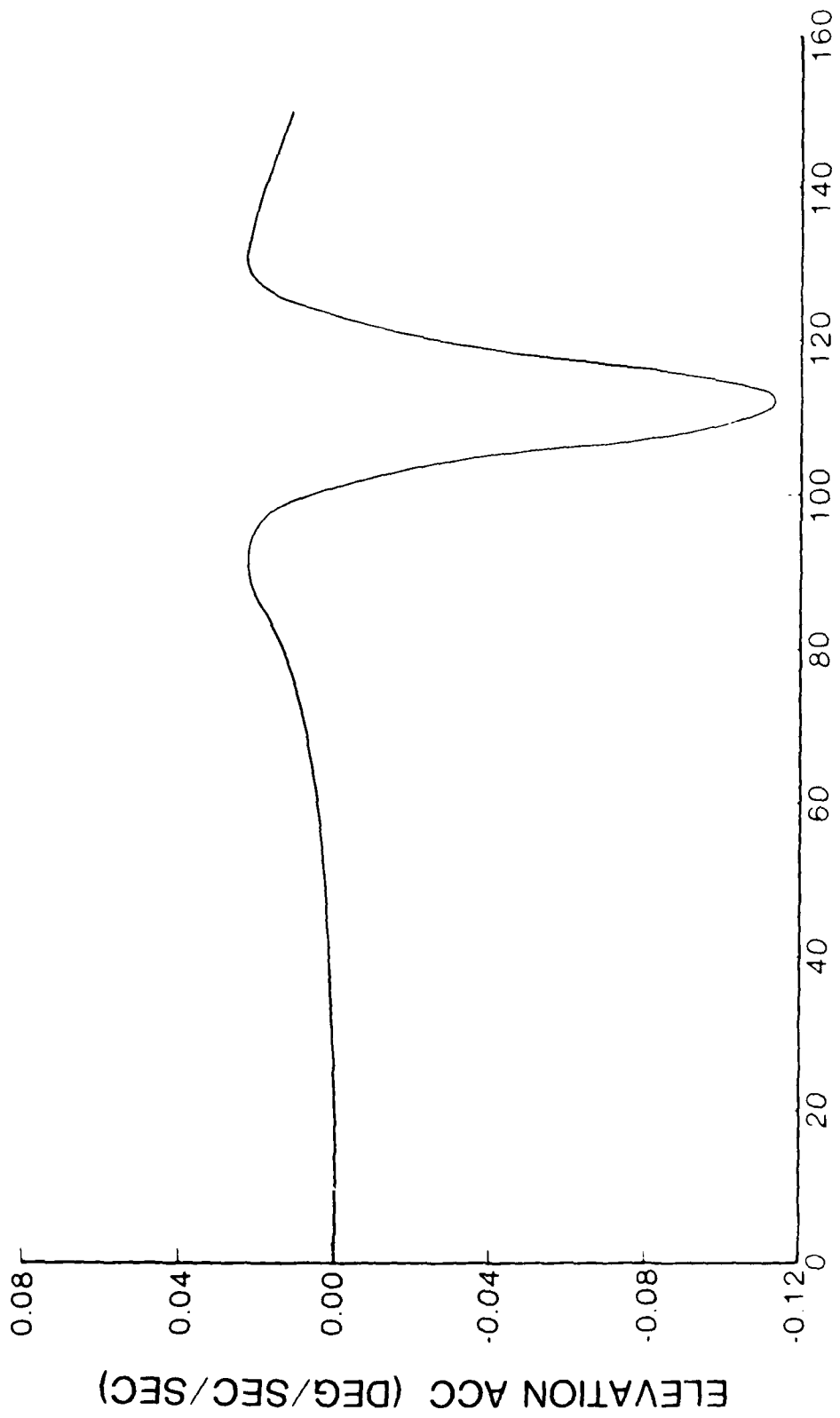

TIME (SEC)
FLYBY 1B

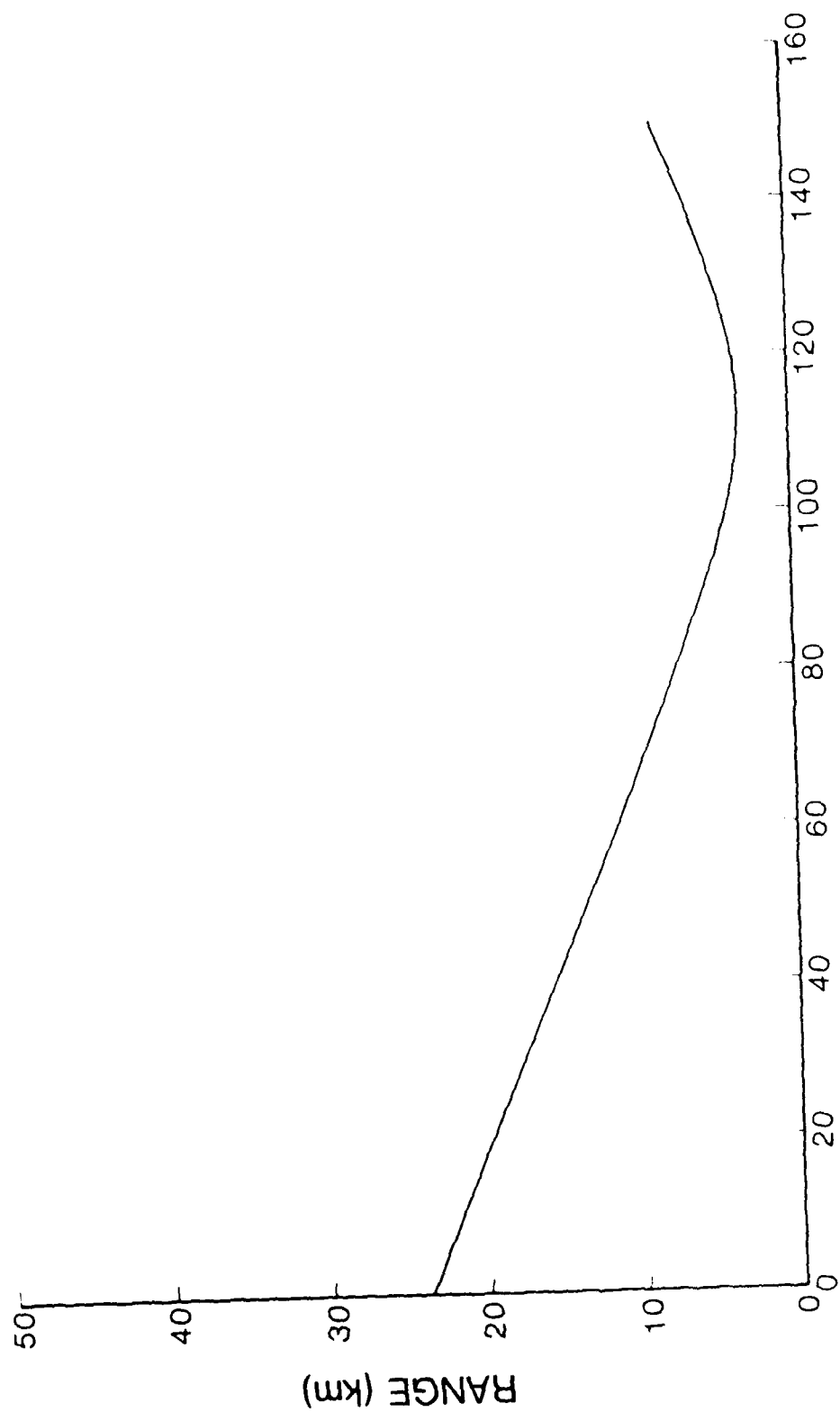

TIME (SEC)

FLYBY 1B

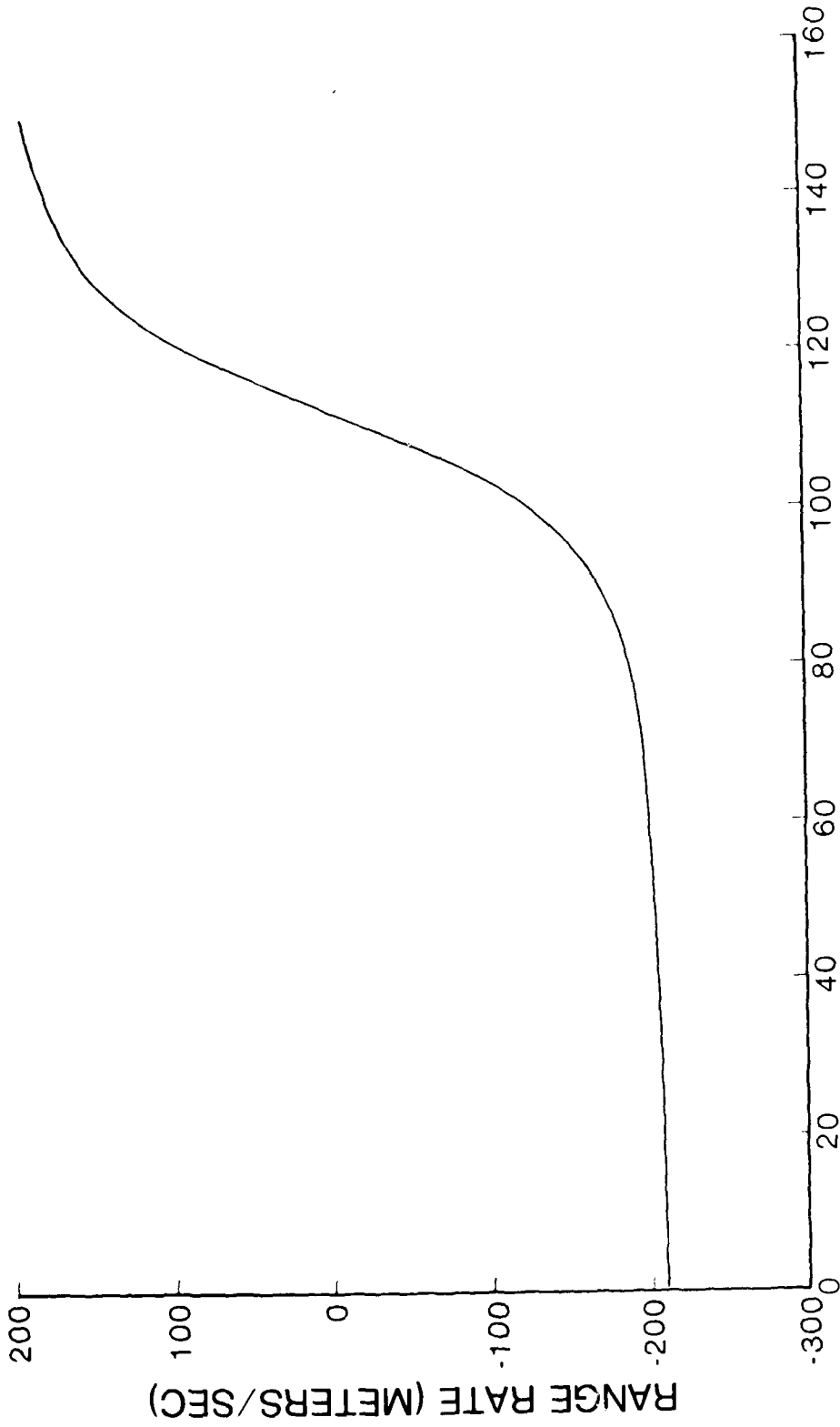

TIME (SEC)

FLYBY 1B

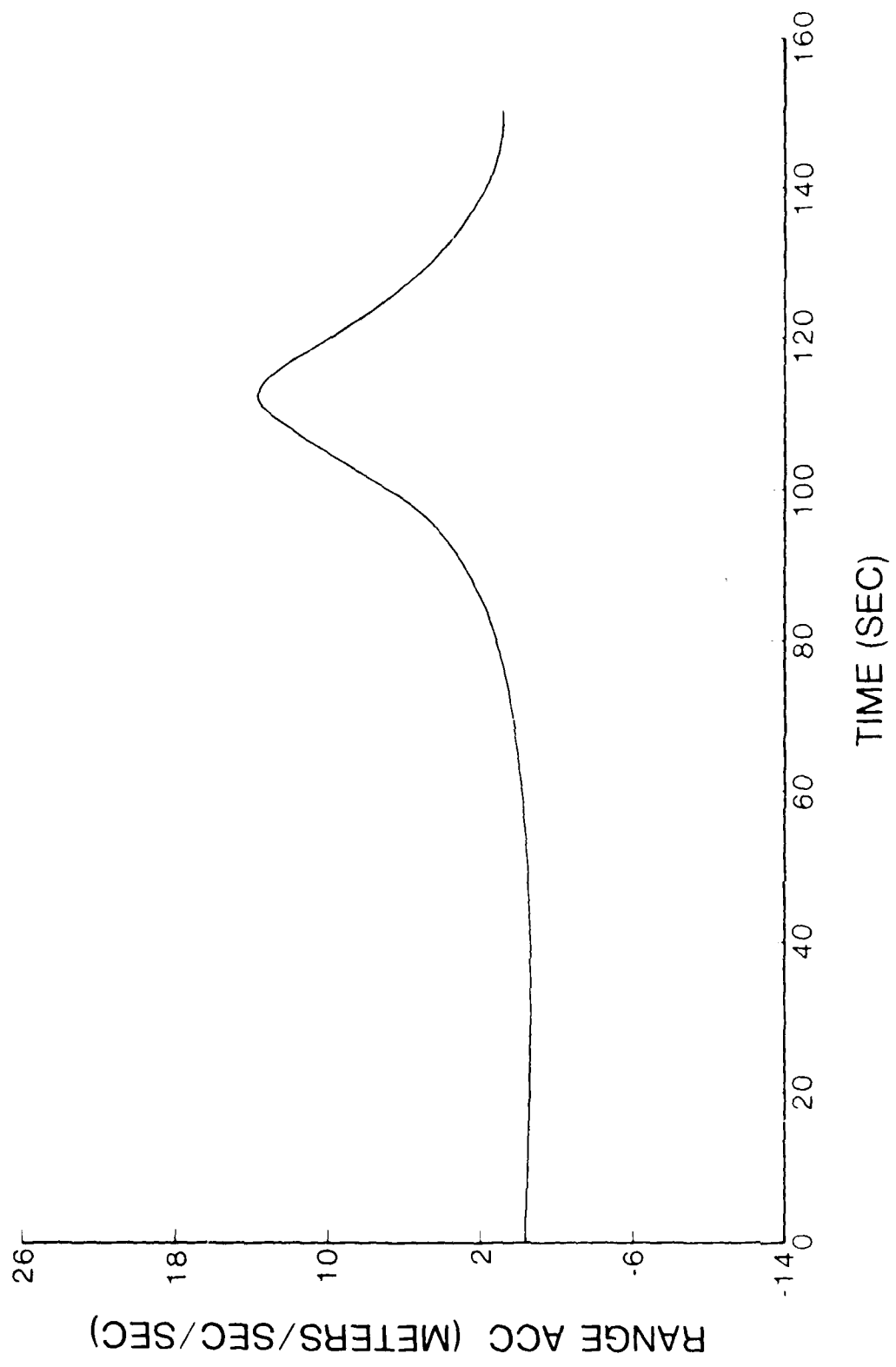

FLYBY 1B

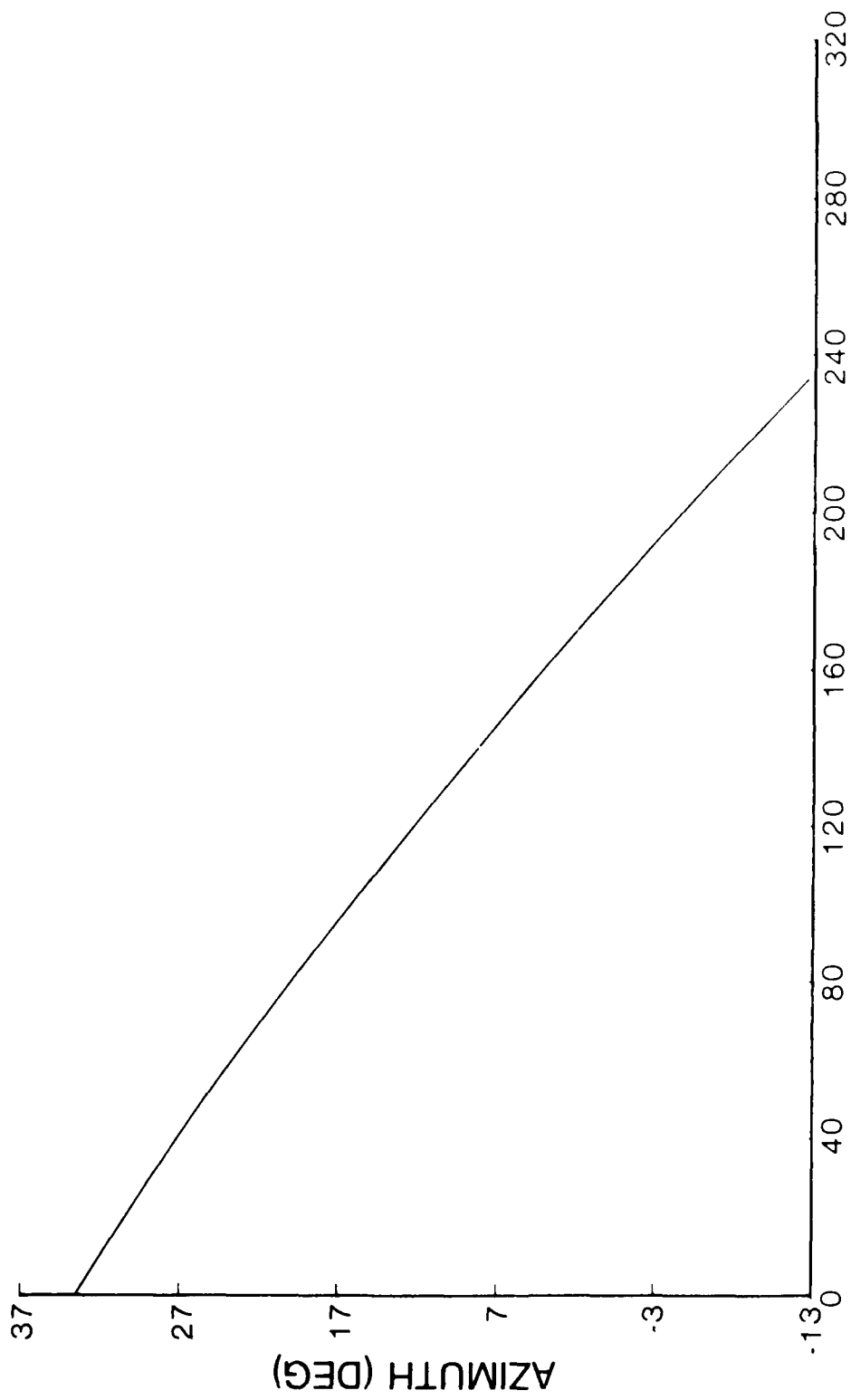

TIME (SEC)
SLOW 5A

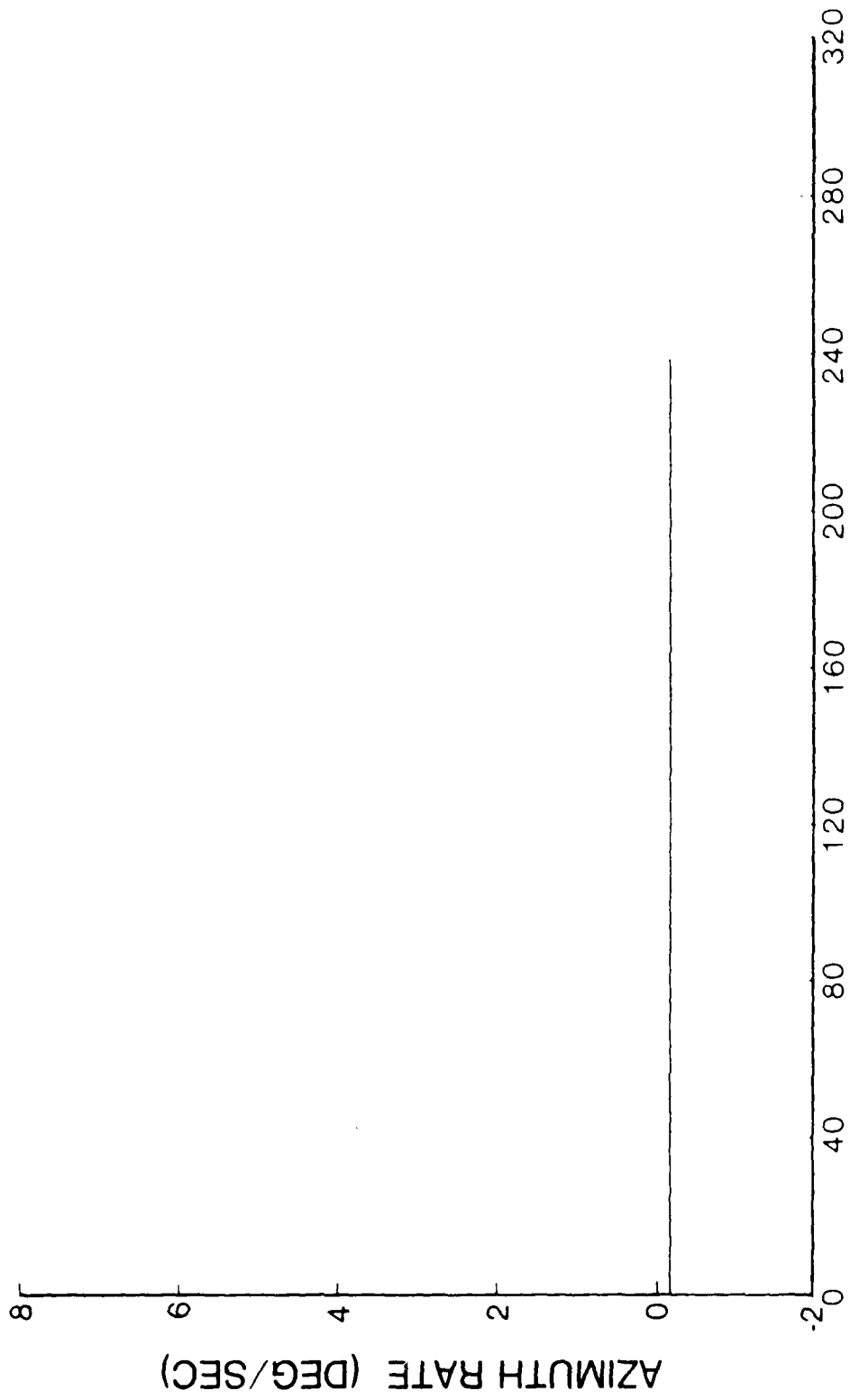

TIME (SEC)
SLOW 5A

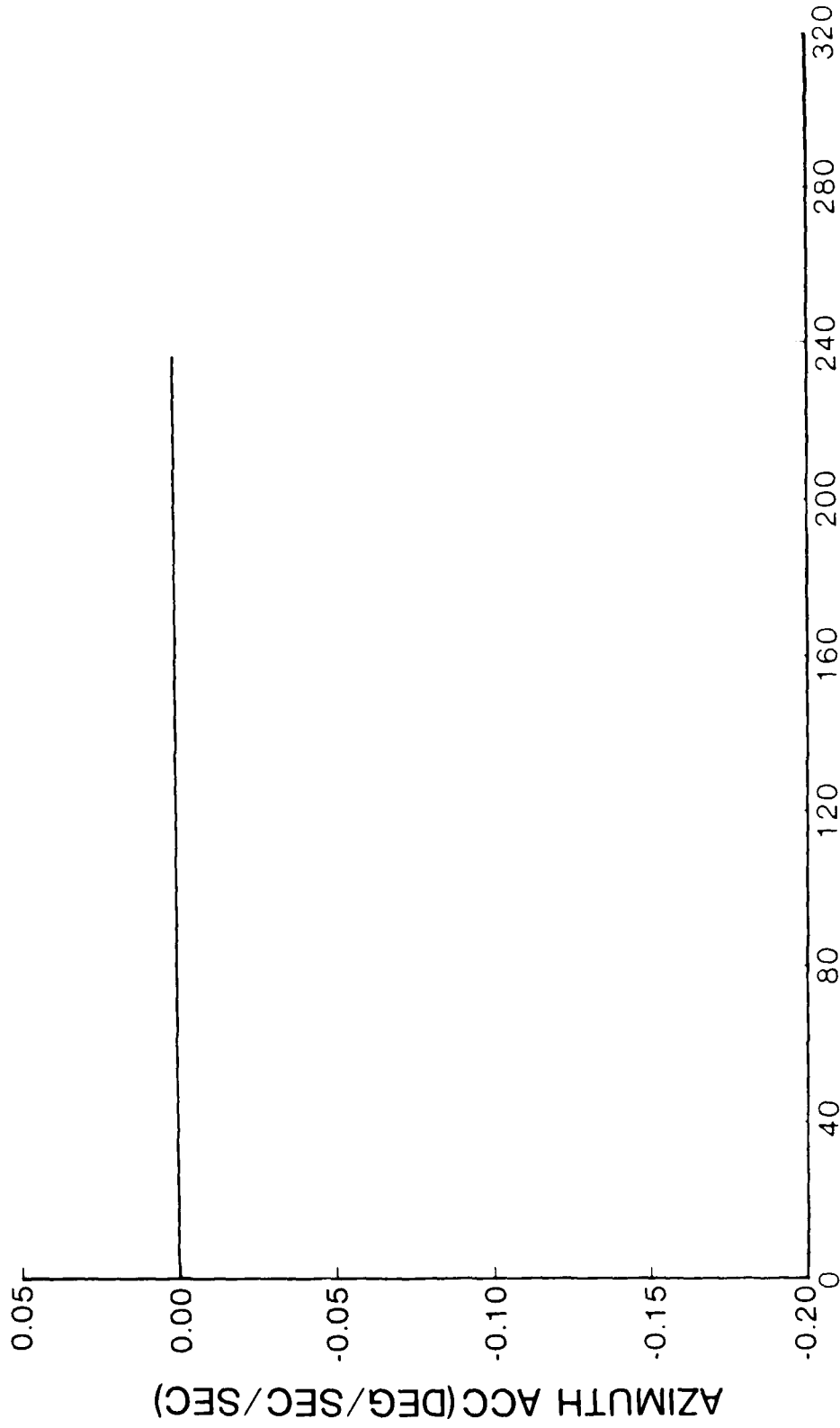

TIME (SEC)
SLOW 5A

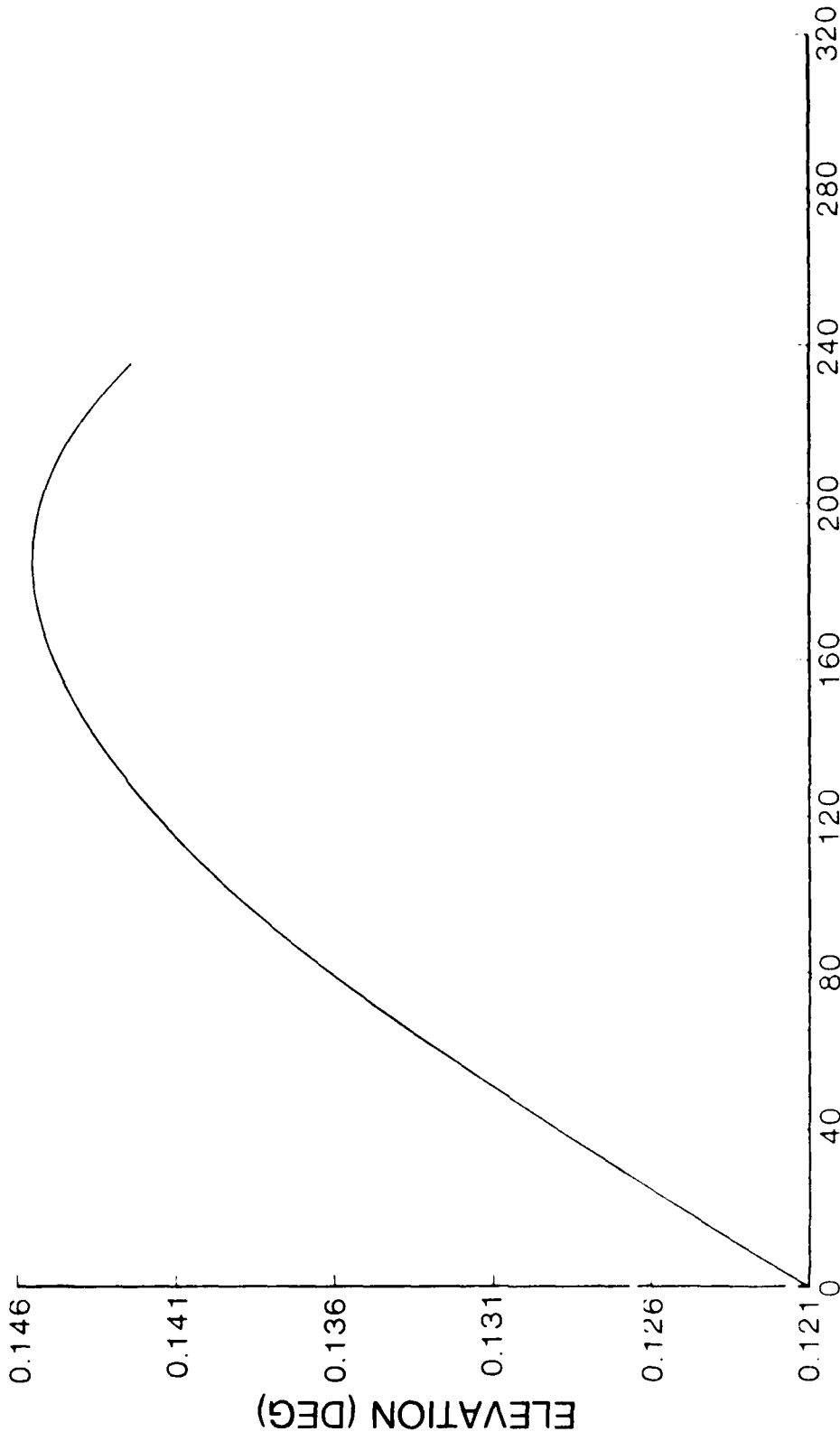

TIME (SEC)
SLOW 5A

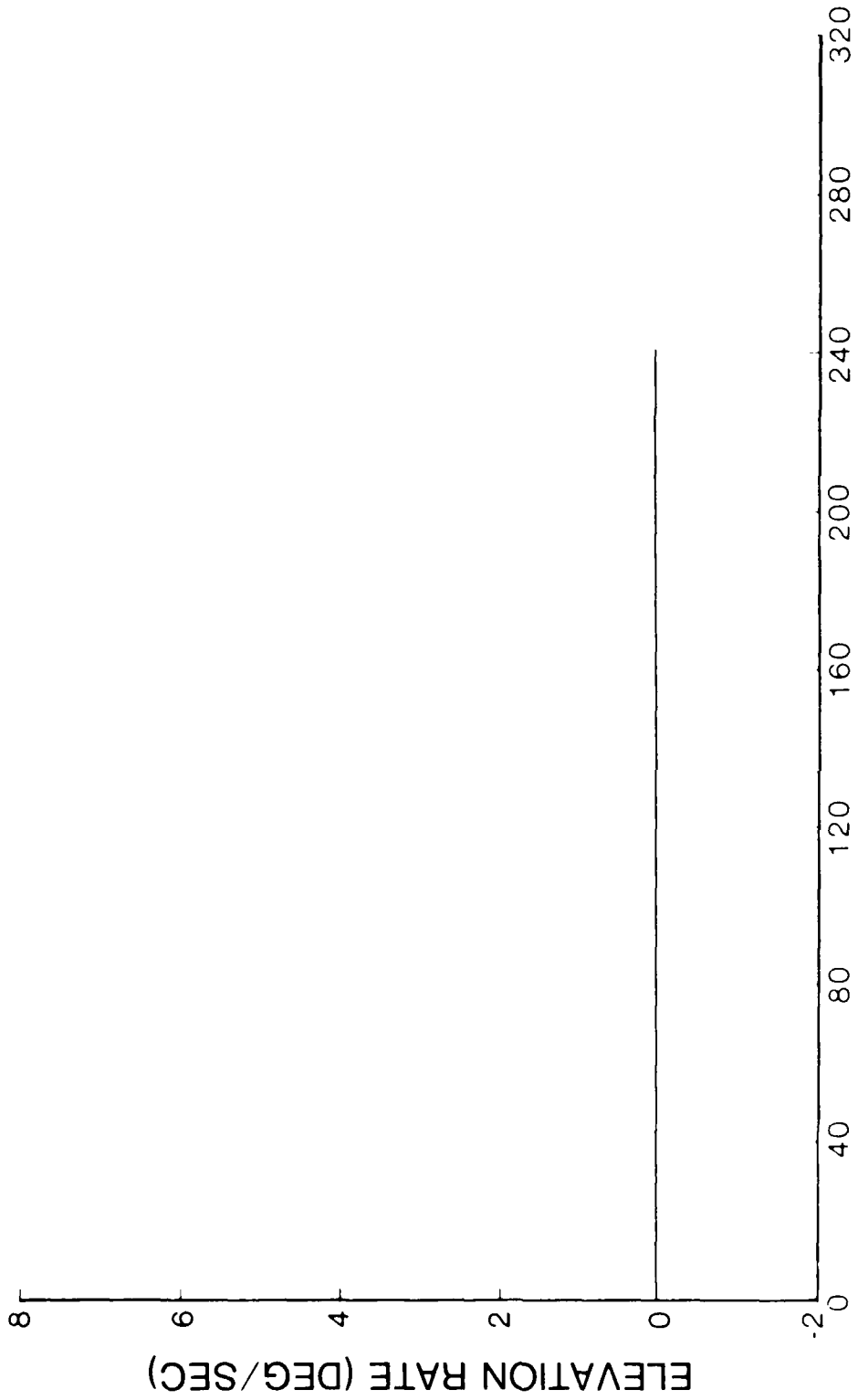

TIME (SEC)
SLOW 5A

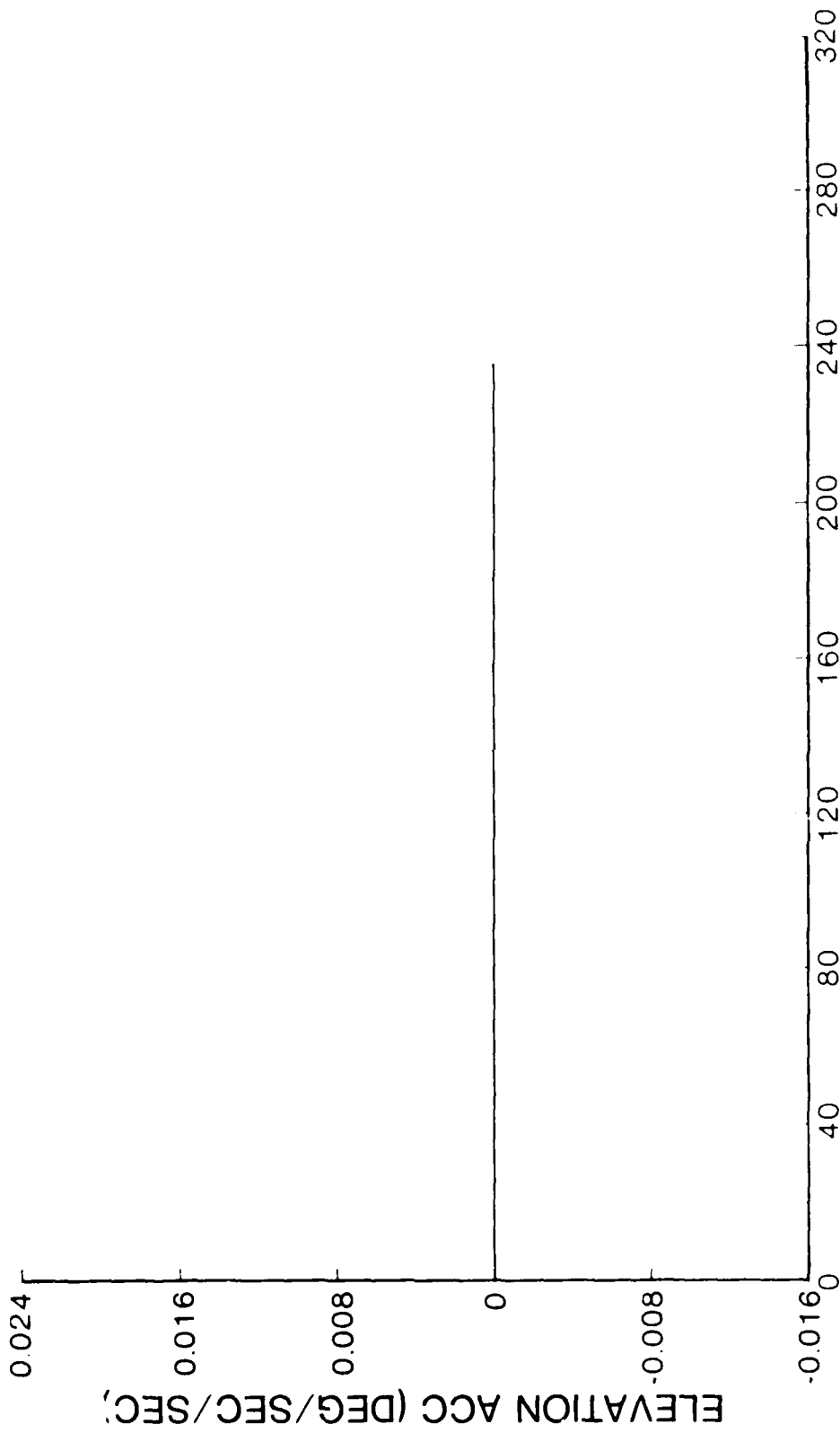

TIME (SEC)
SLOW 5A

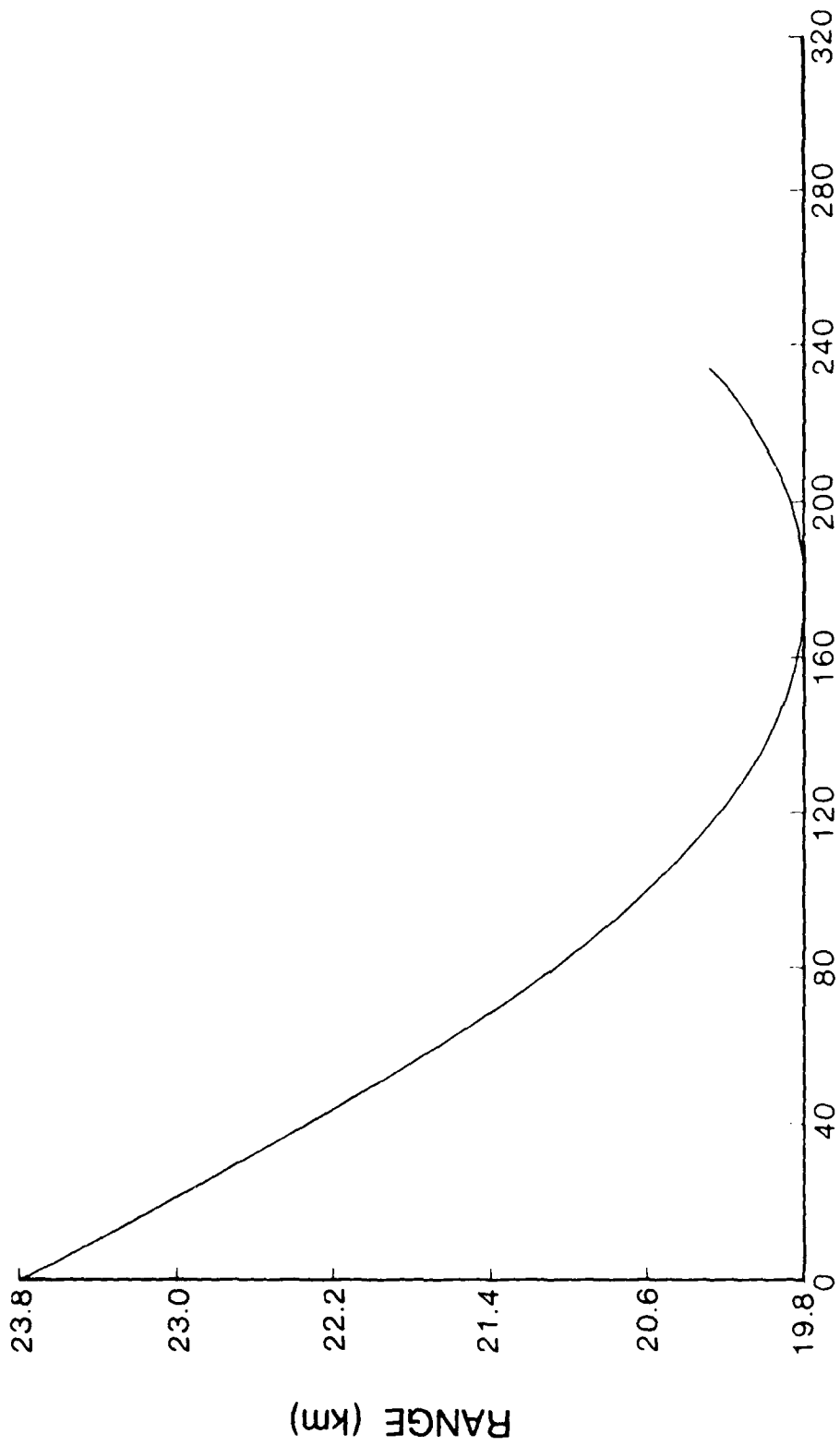

TIME (SEC)
SLOW 5A

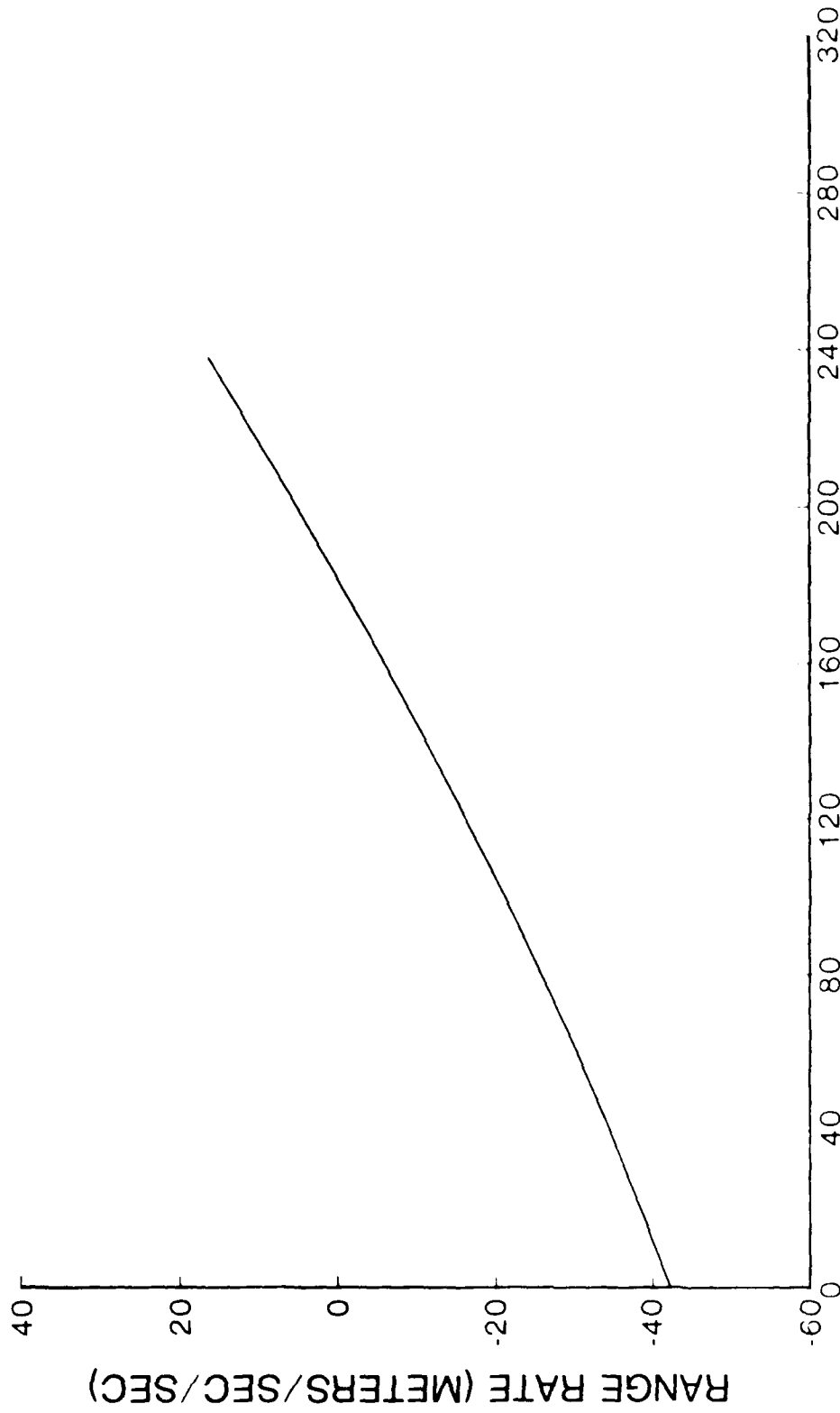

TIME (SEC)
SLOW 5A

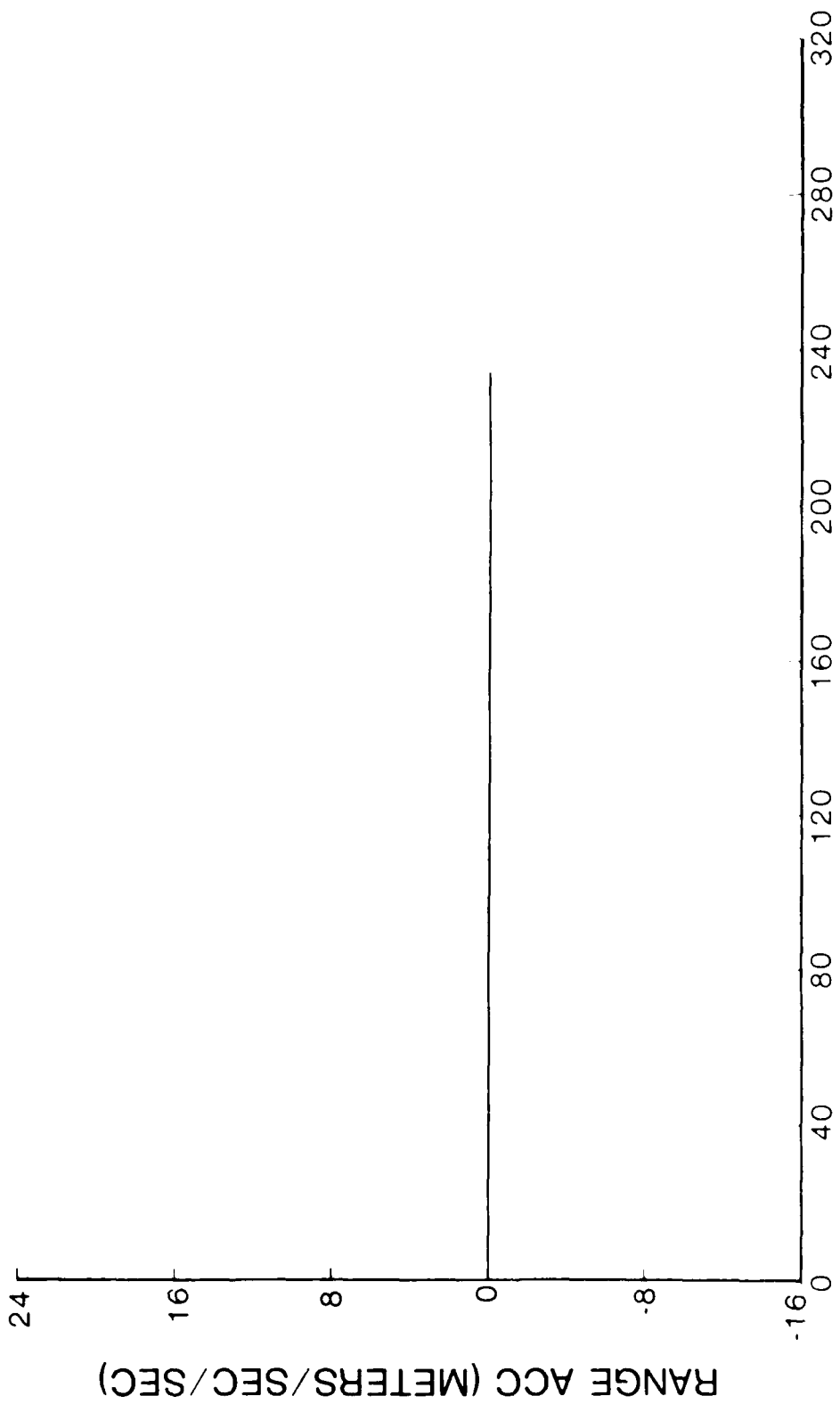

TIME (SEC)
SLOW 5A

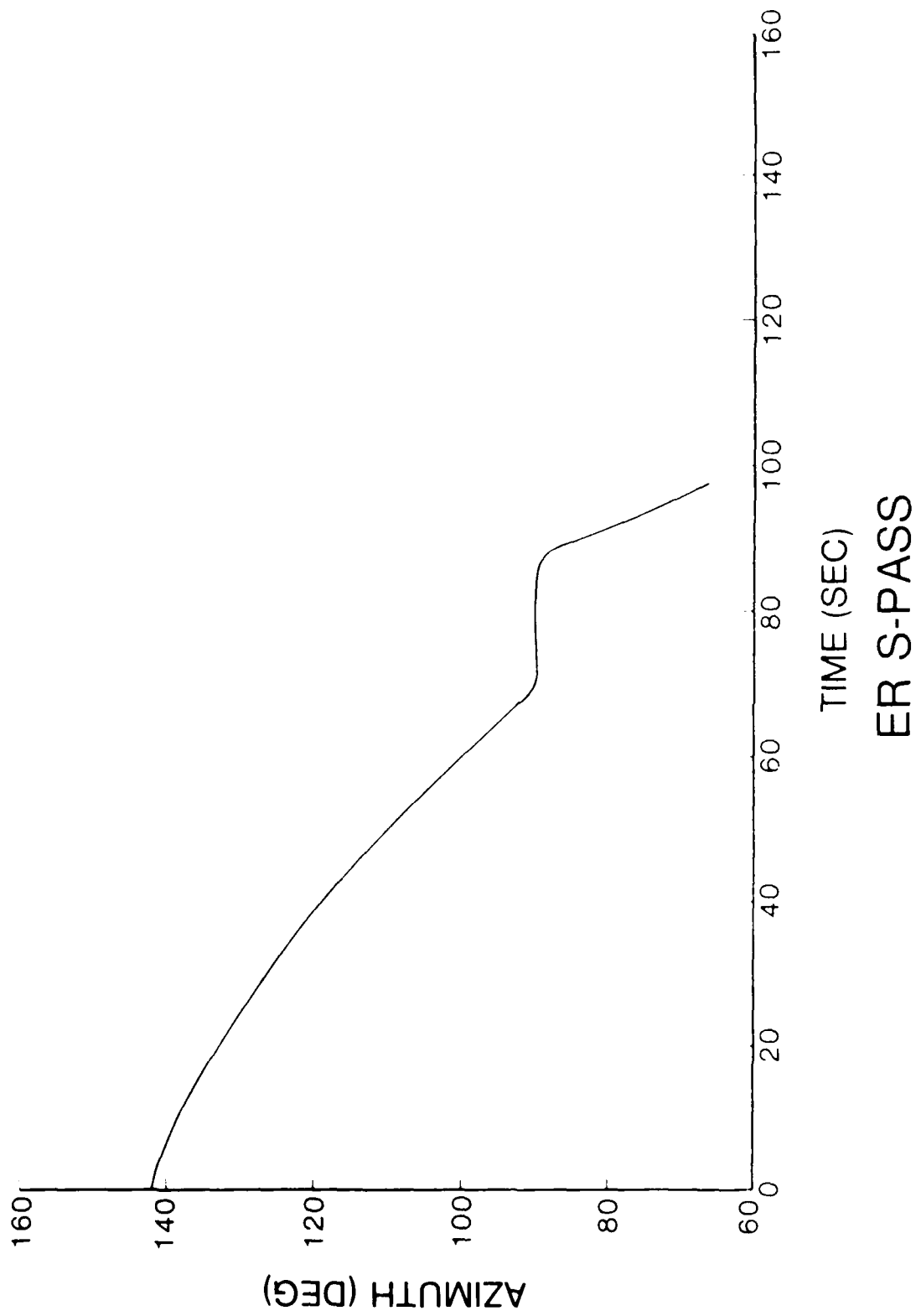

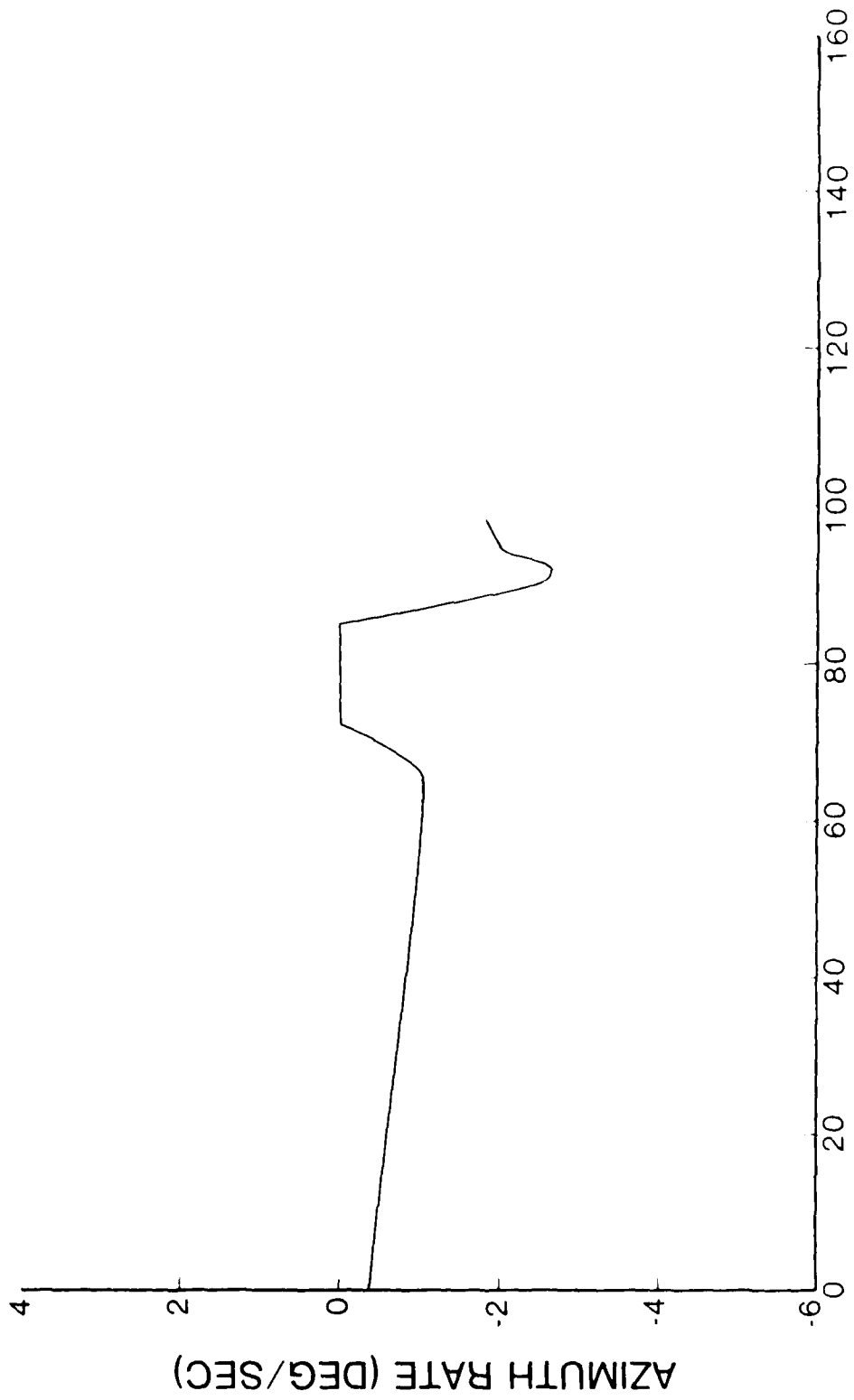

TIME (SEC)
ER S-PASS

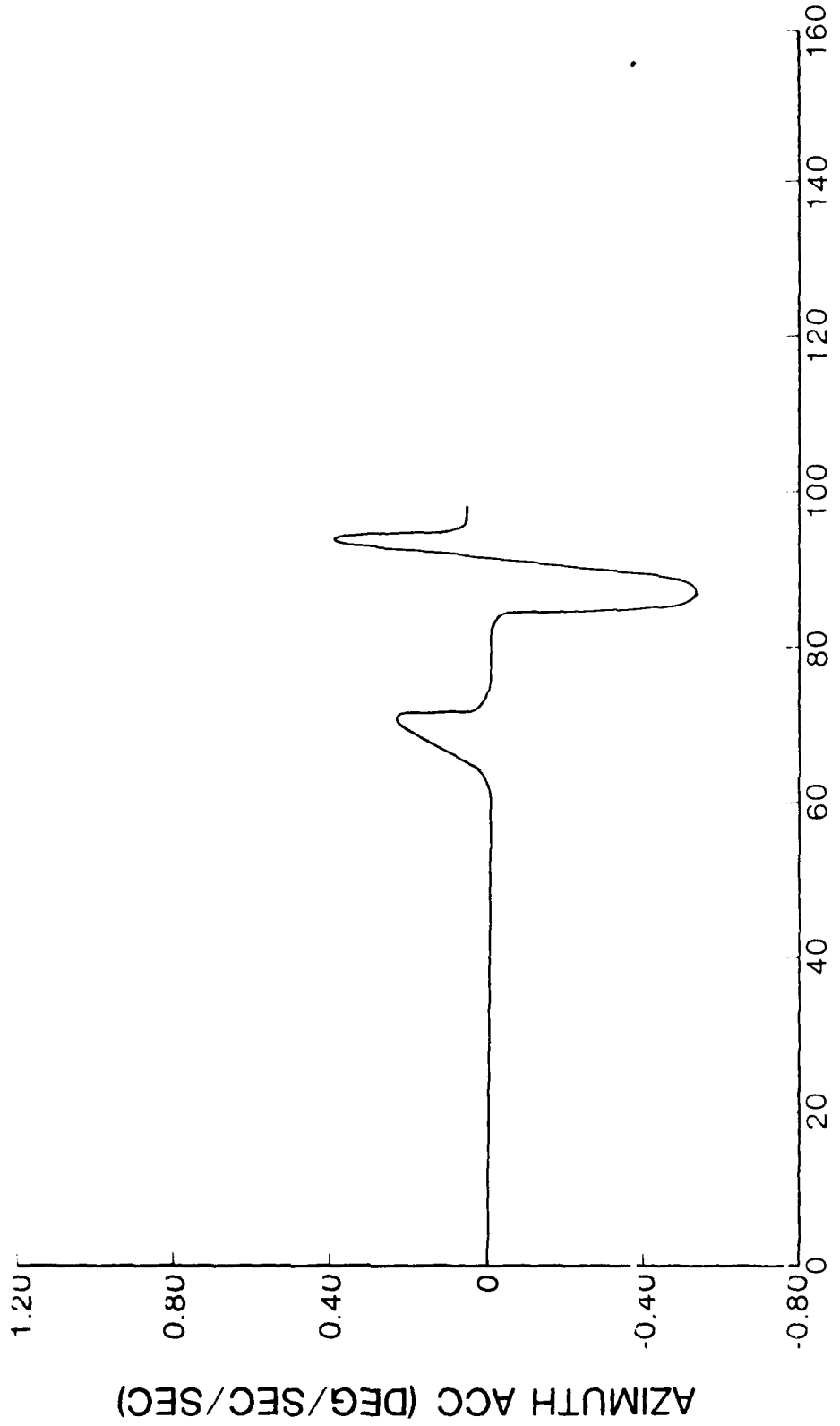

TIME (SEC)
ER S-PASS

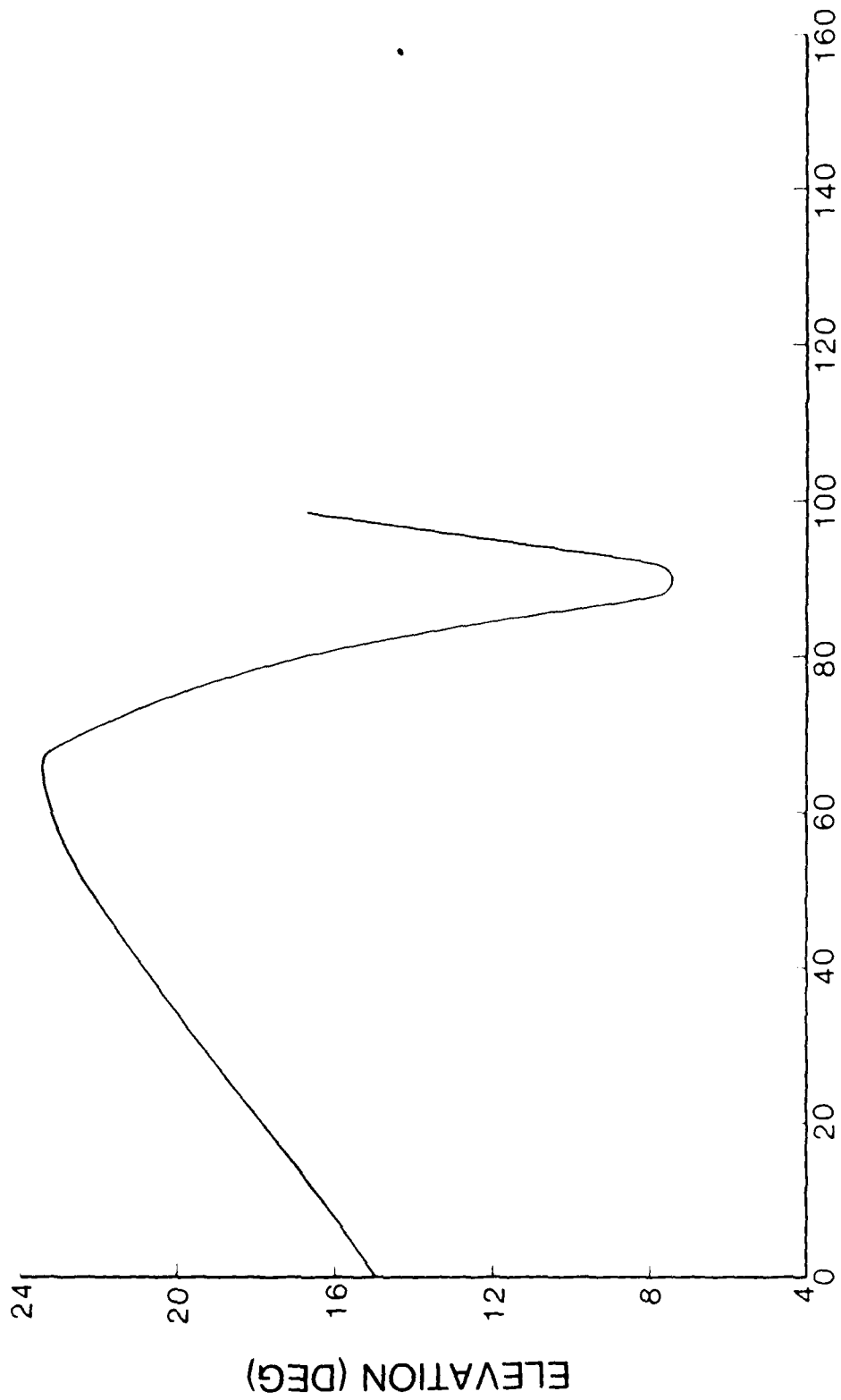

TIME (SEC)
ER S-PASS

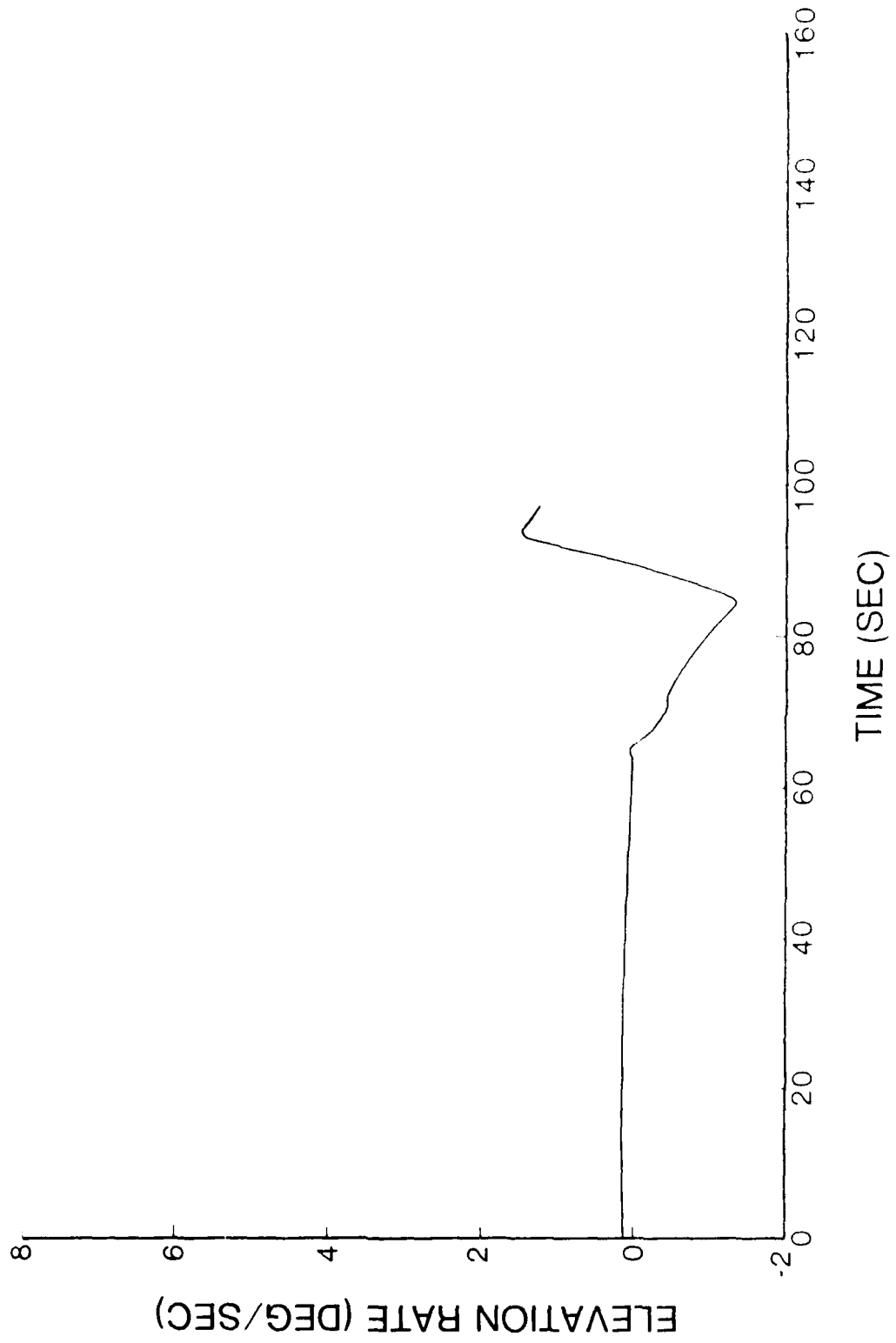

ER S-PASS

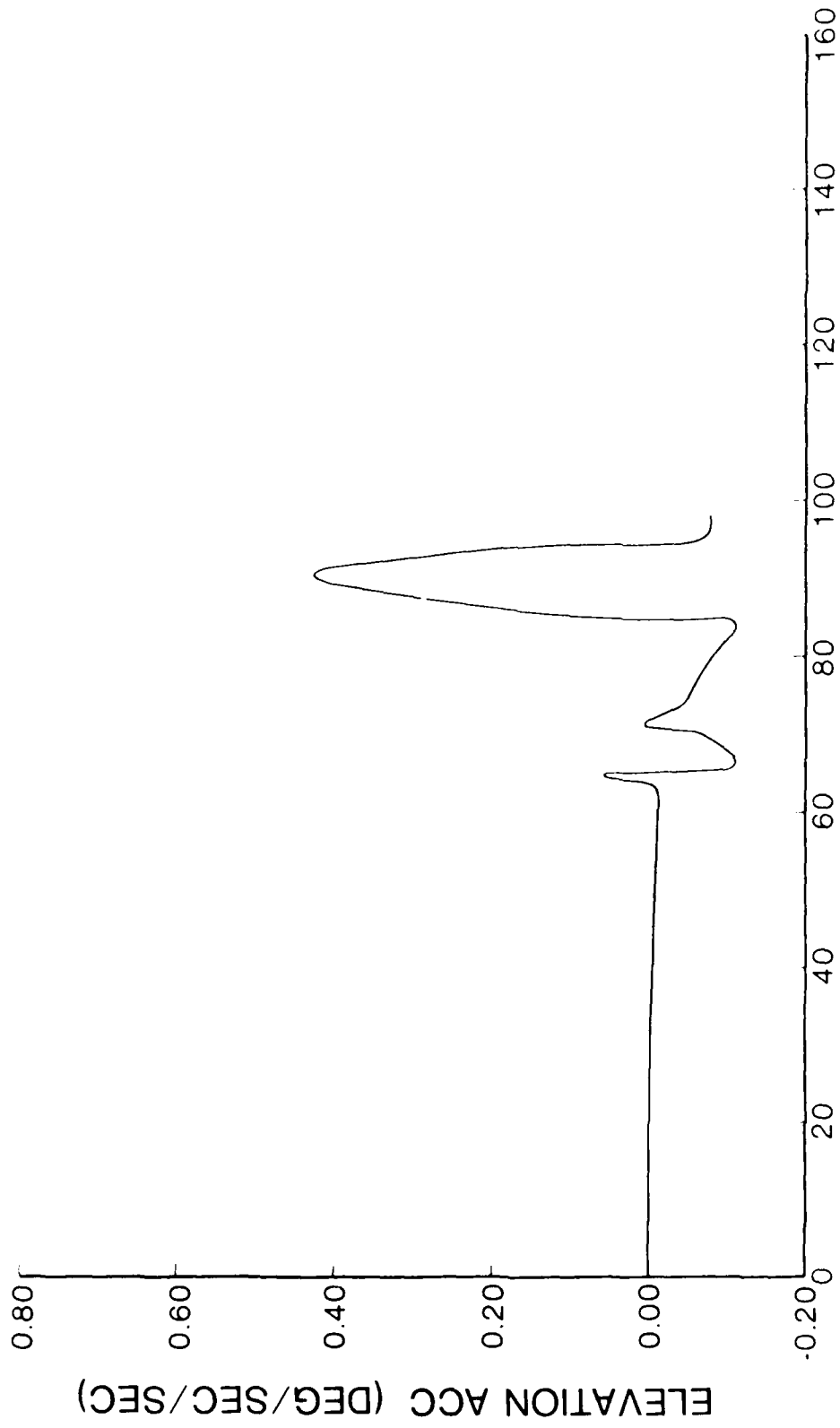

TIME (SEC)
ER S-PASS

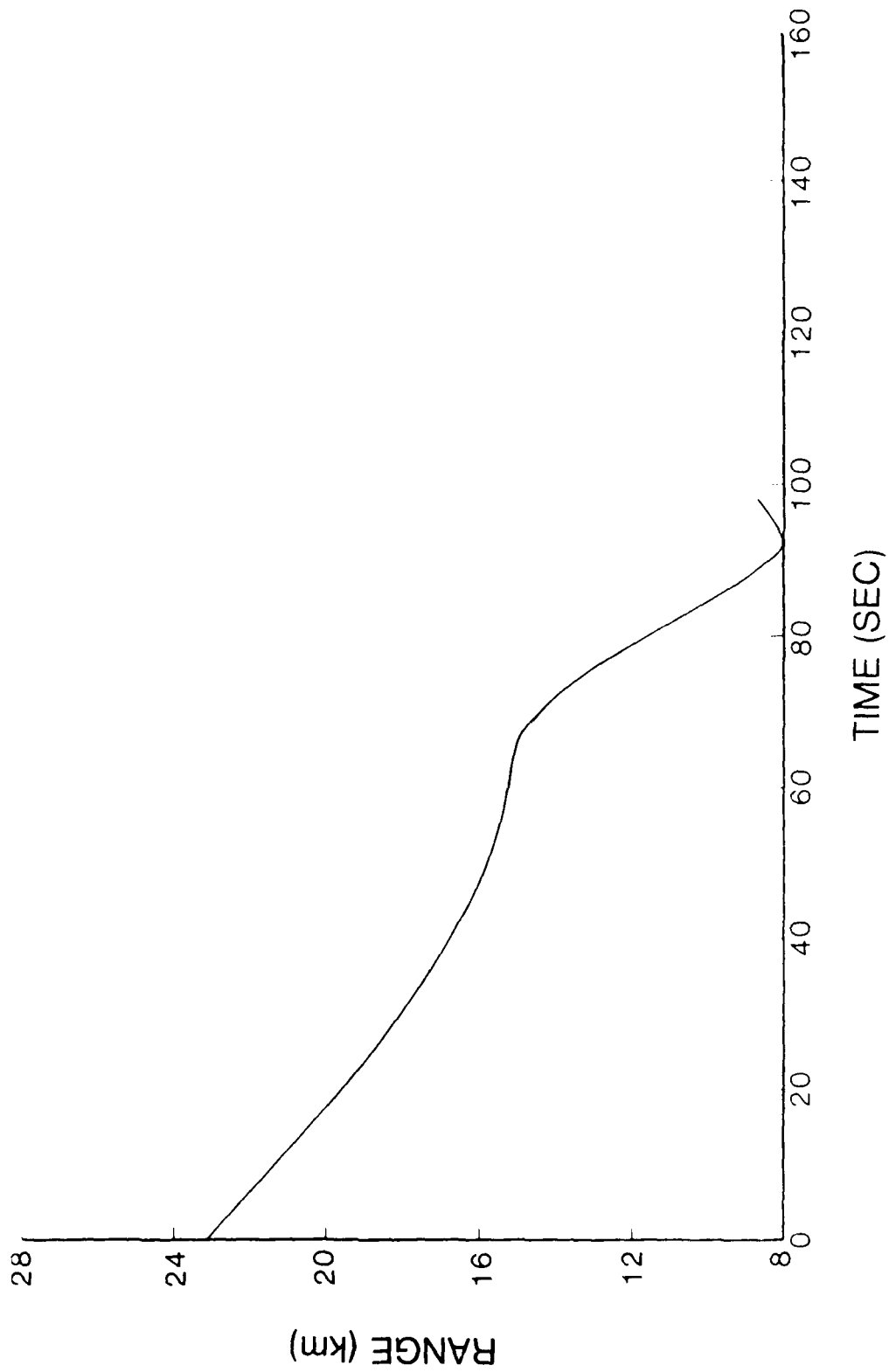

ER S-PASS

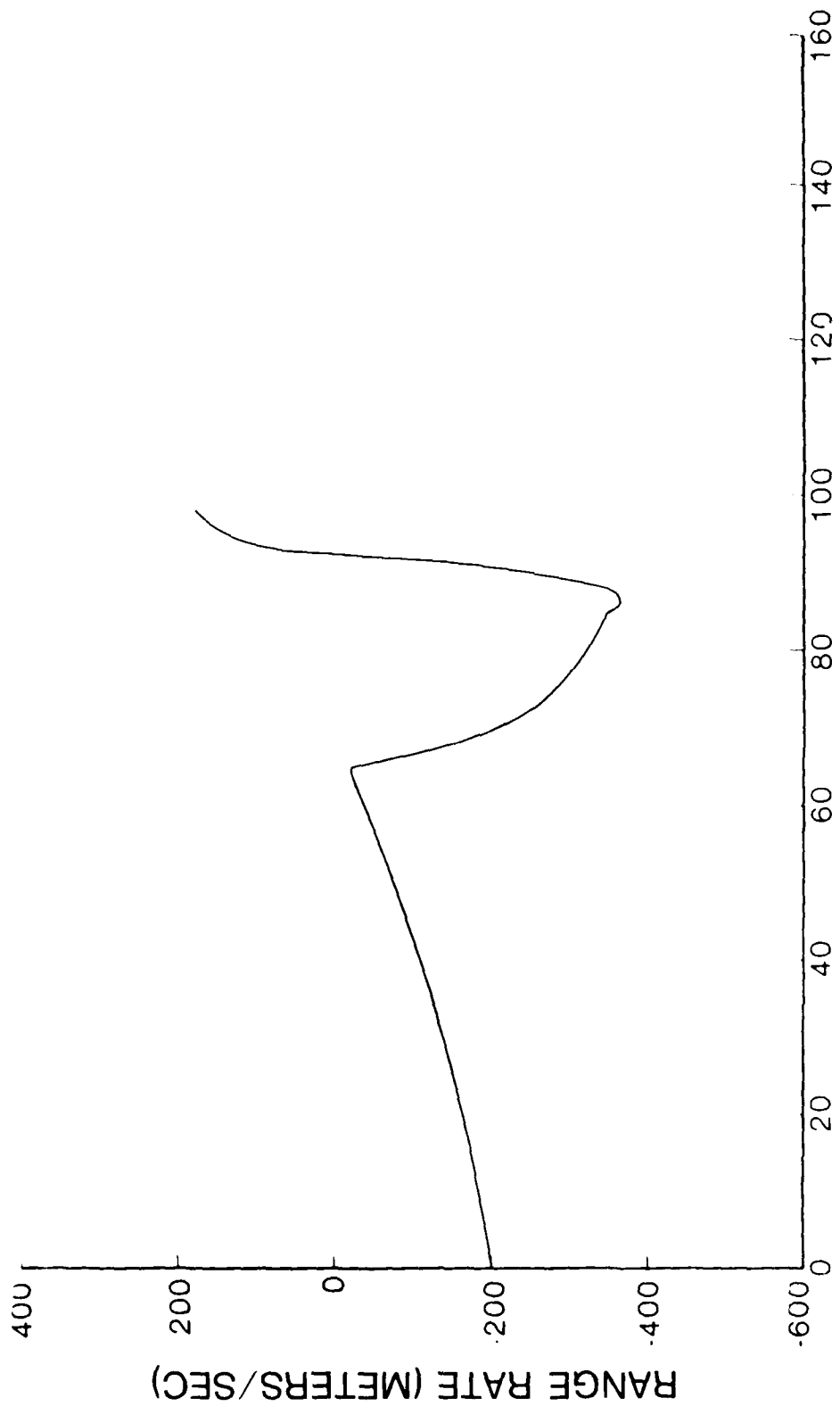

TIME (SEC)
ER S-PASS

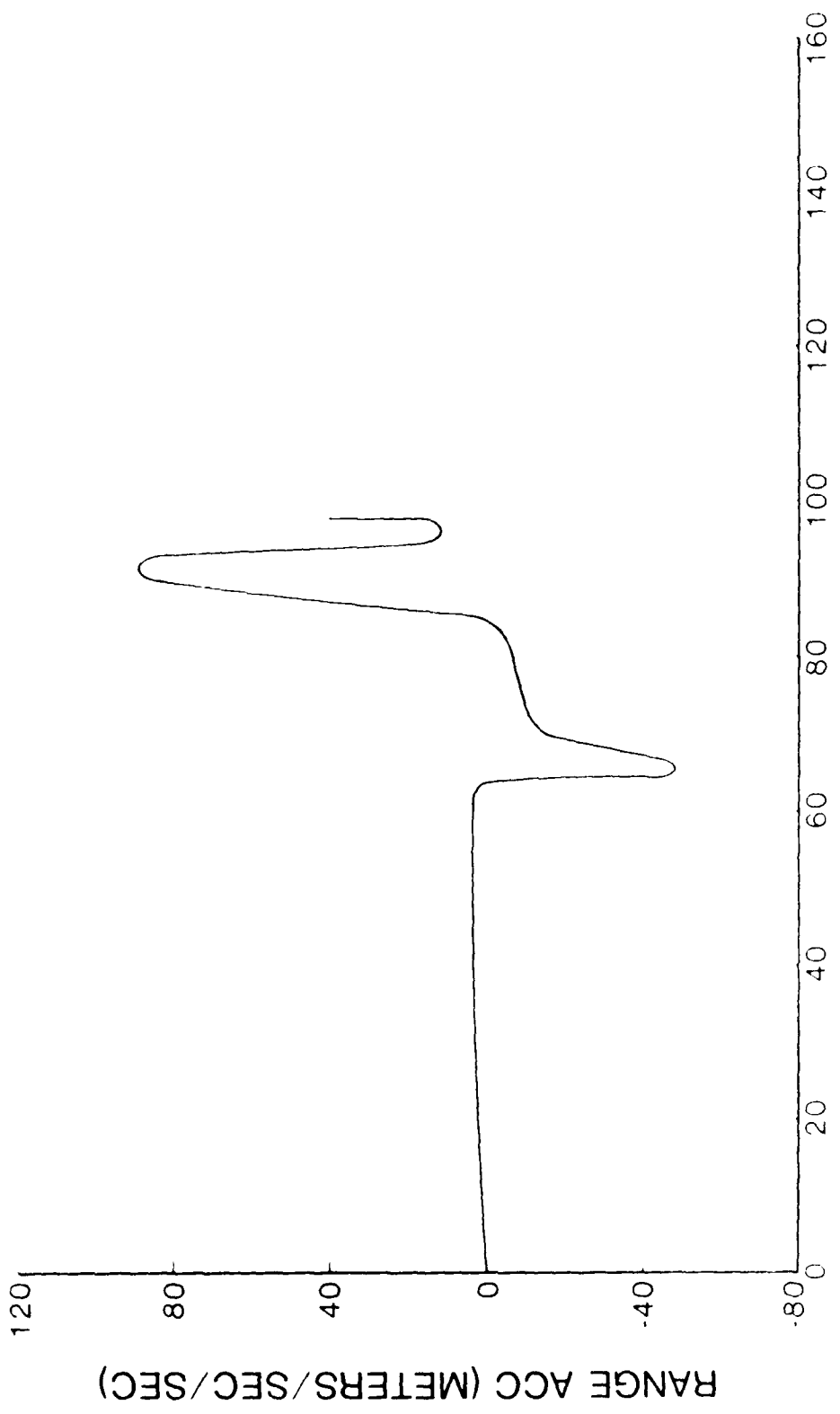

TIME (SEC)
ER S-PASS

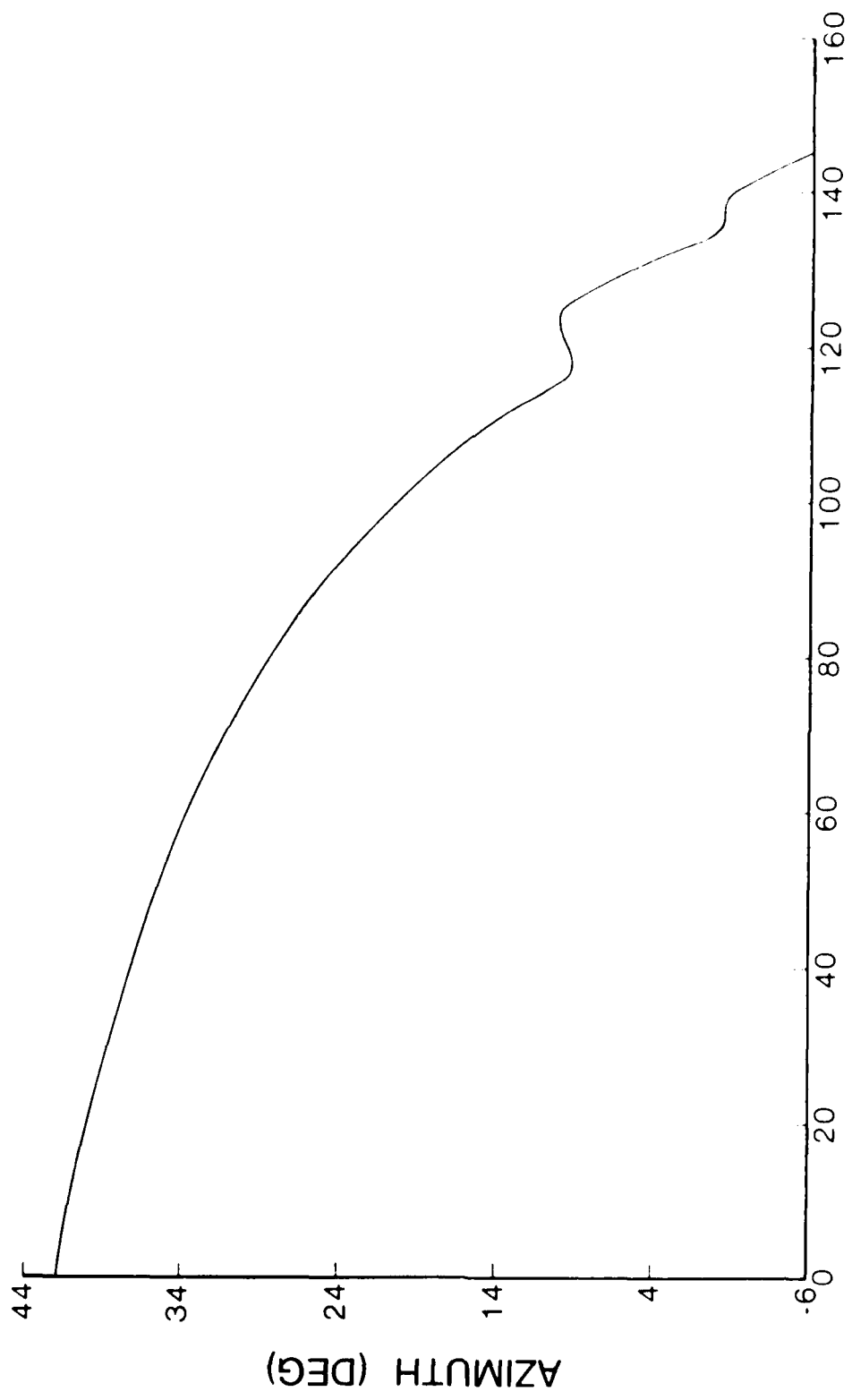

ER ZIG-ZAG

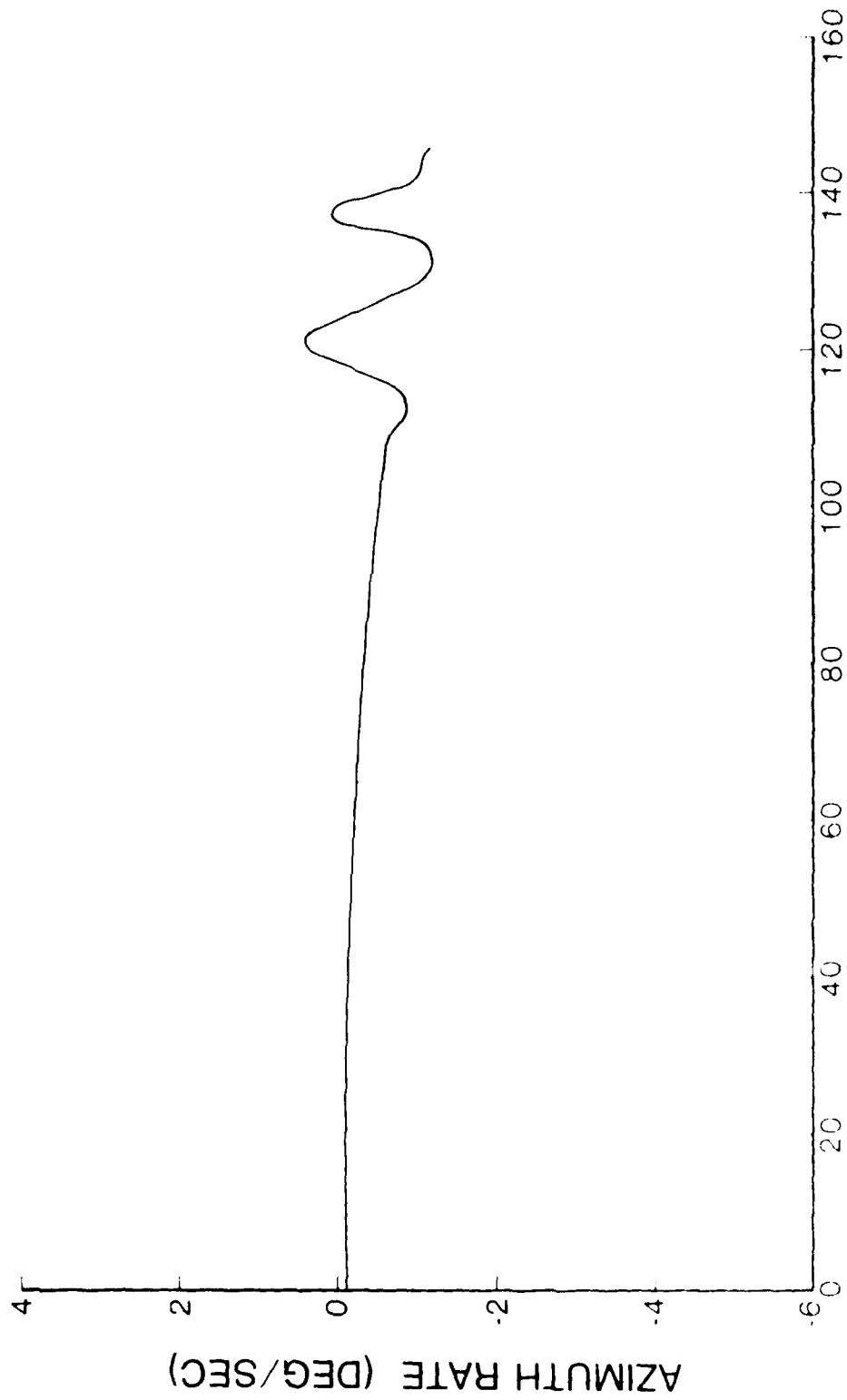

TIME (SEC)
ER ZIG-ZAG

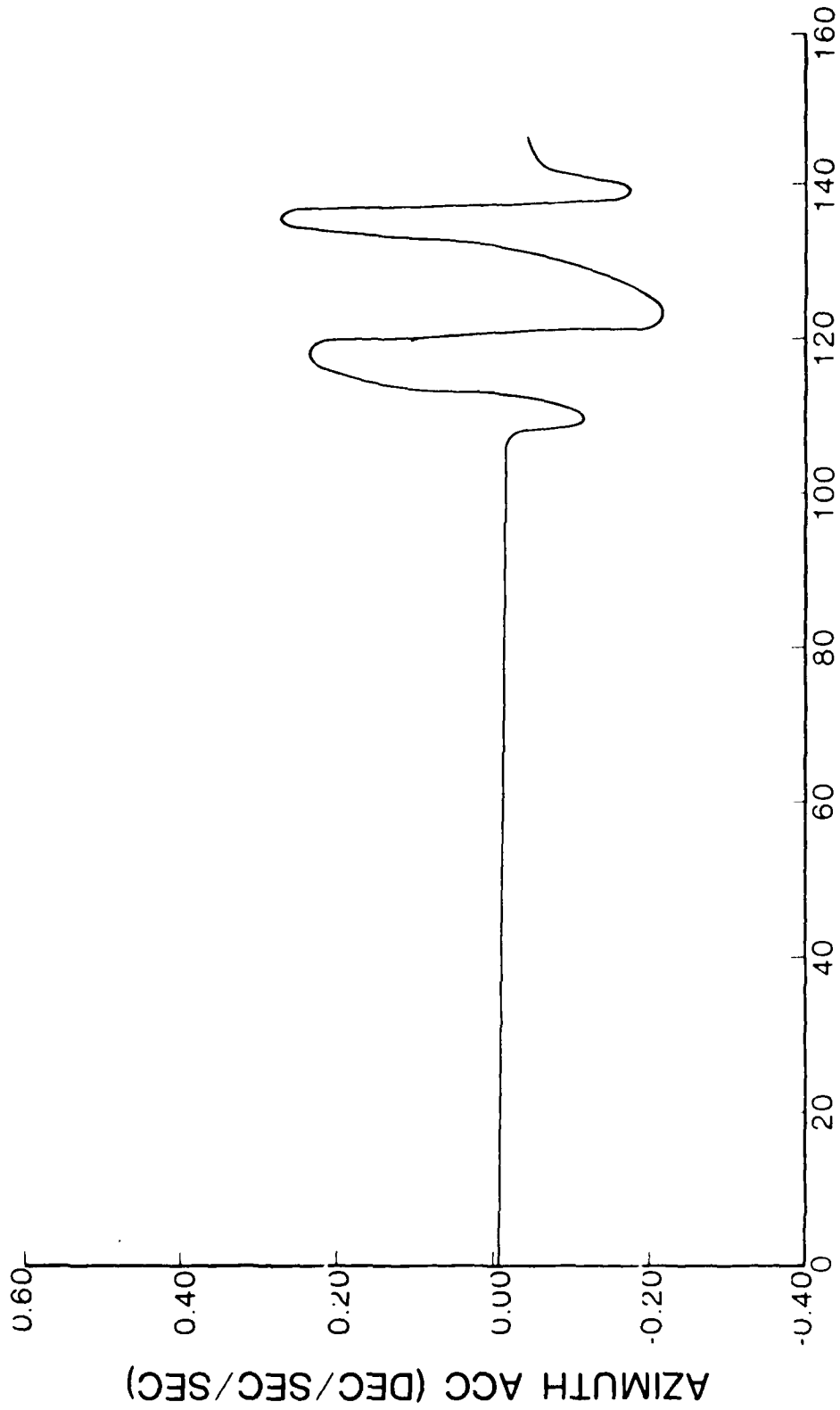

TIME (SEC)
ER ZIG-ZAG

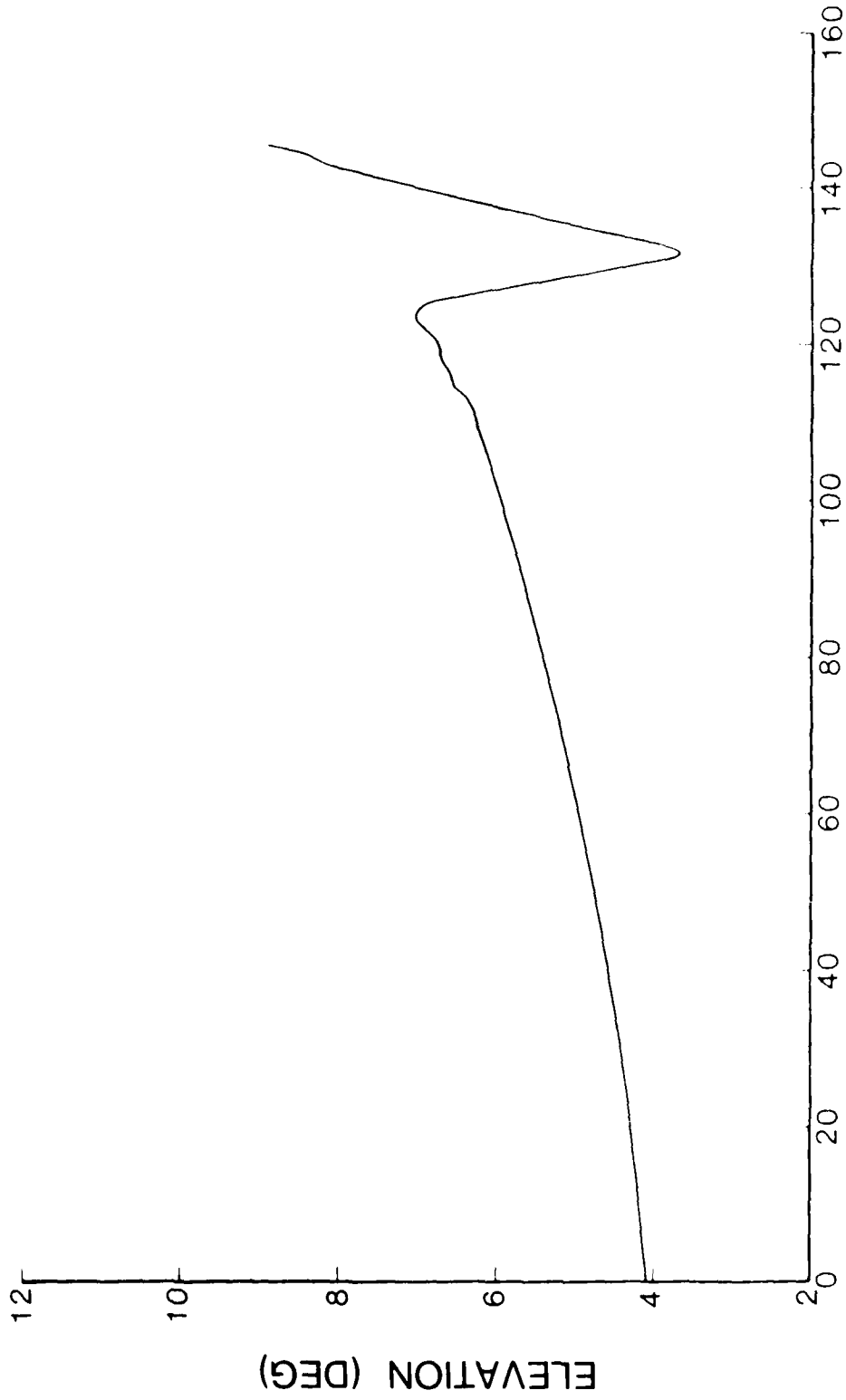

TIME (SEC)
ER ZIG-ZAG

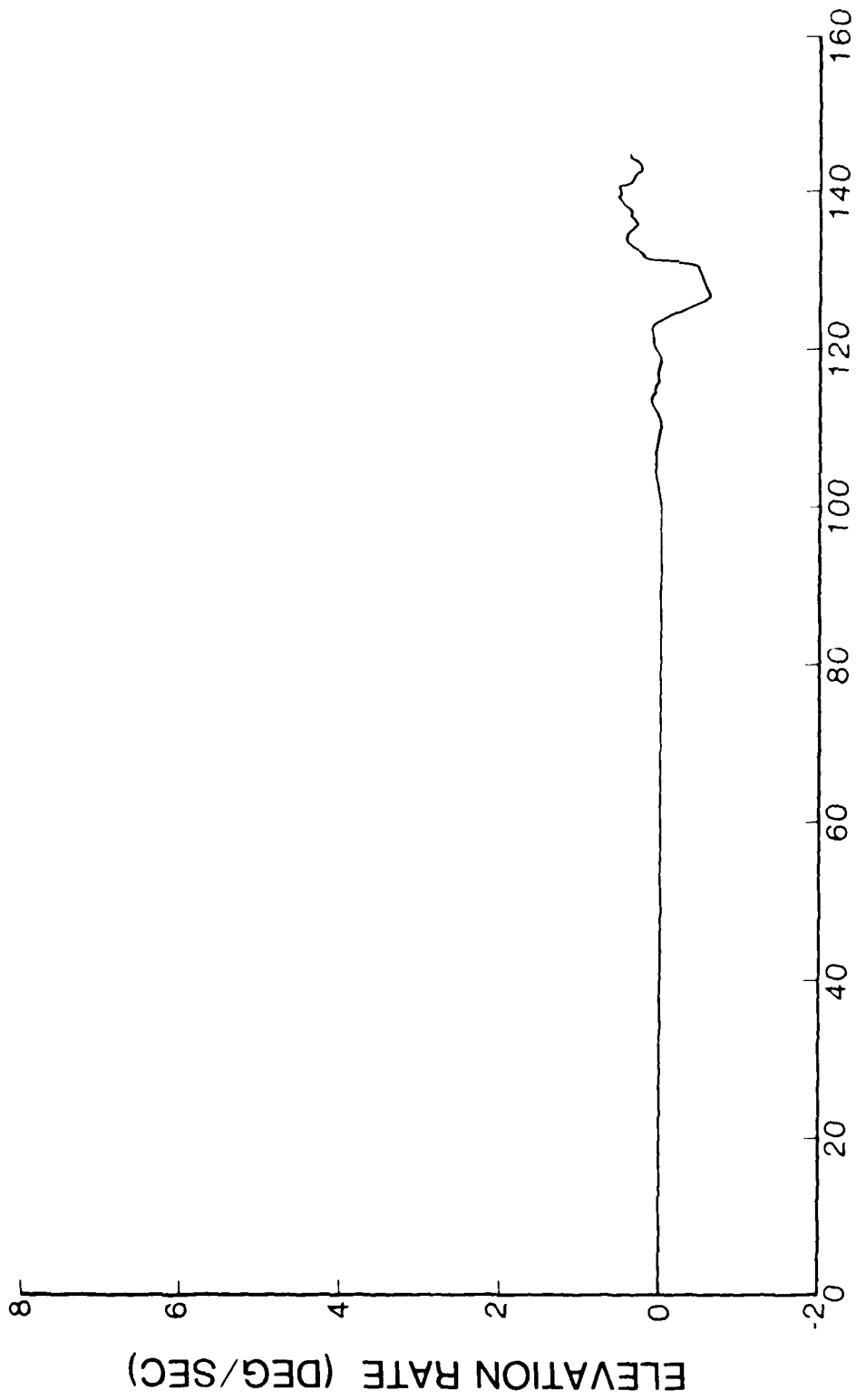

ER ZIG-ZAG

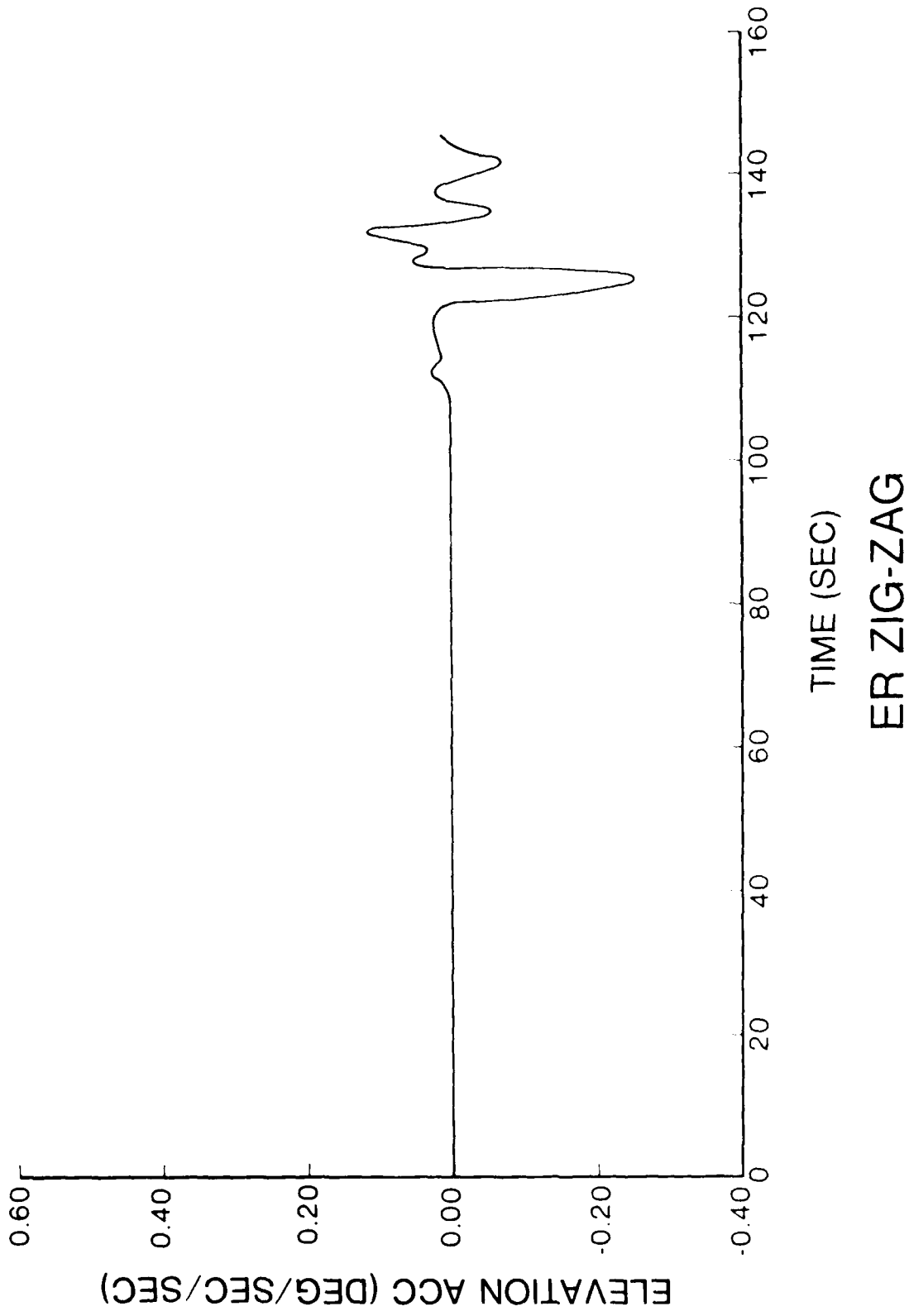

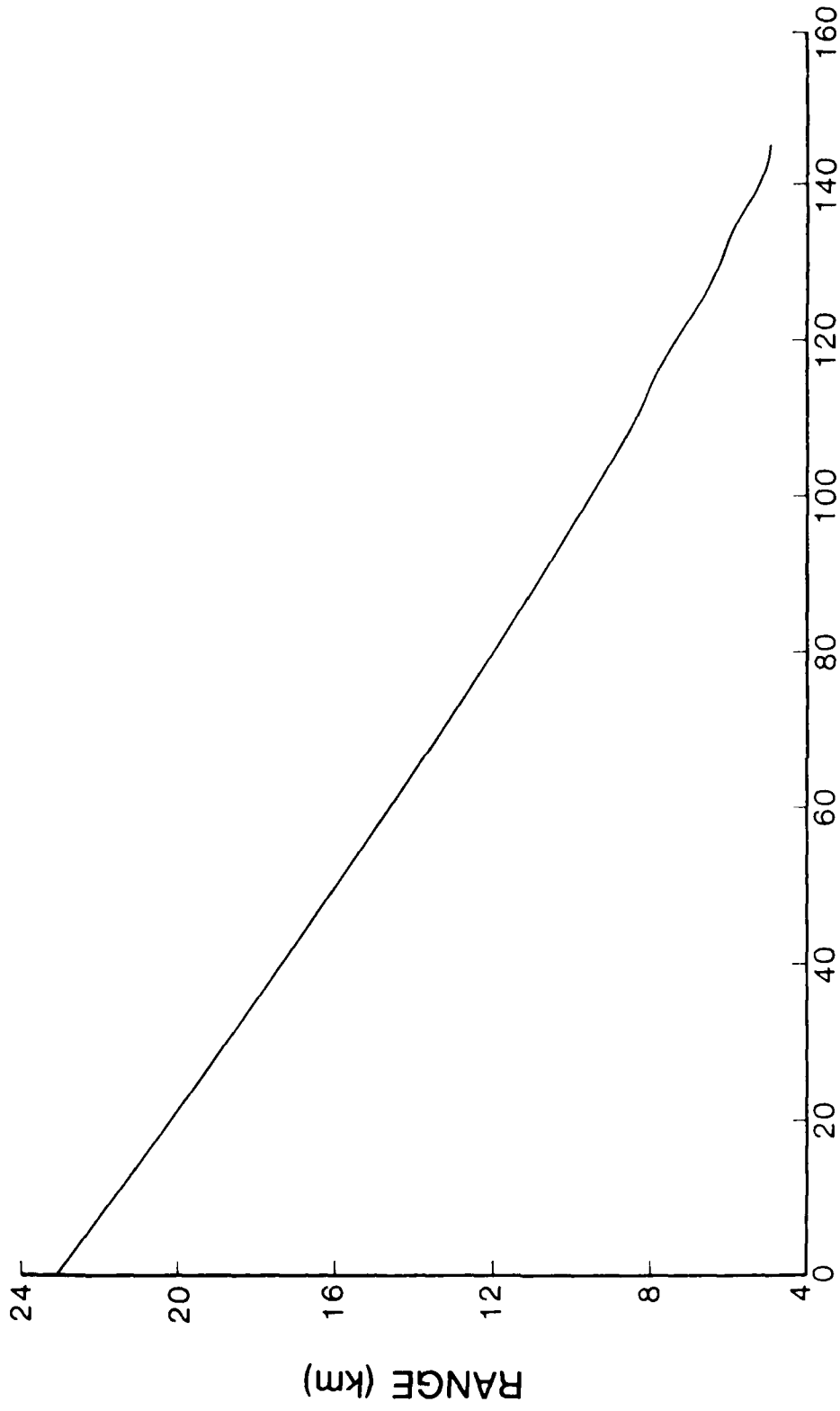

ER ZIG-ZAG

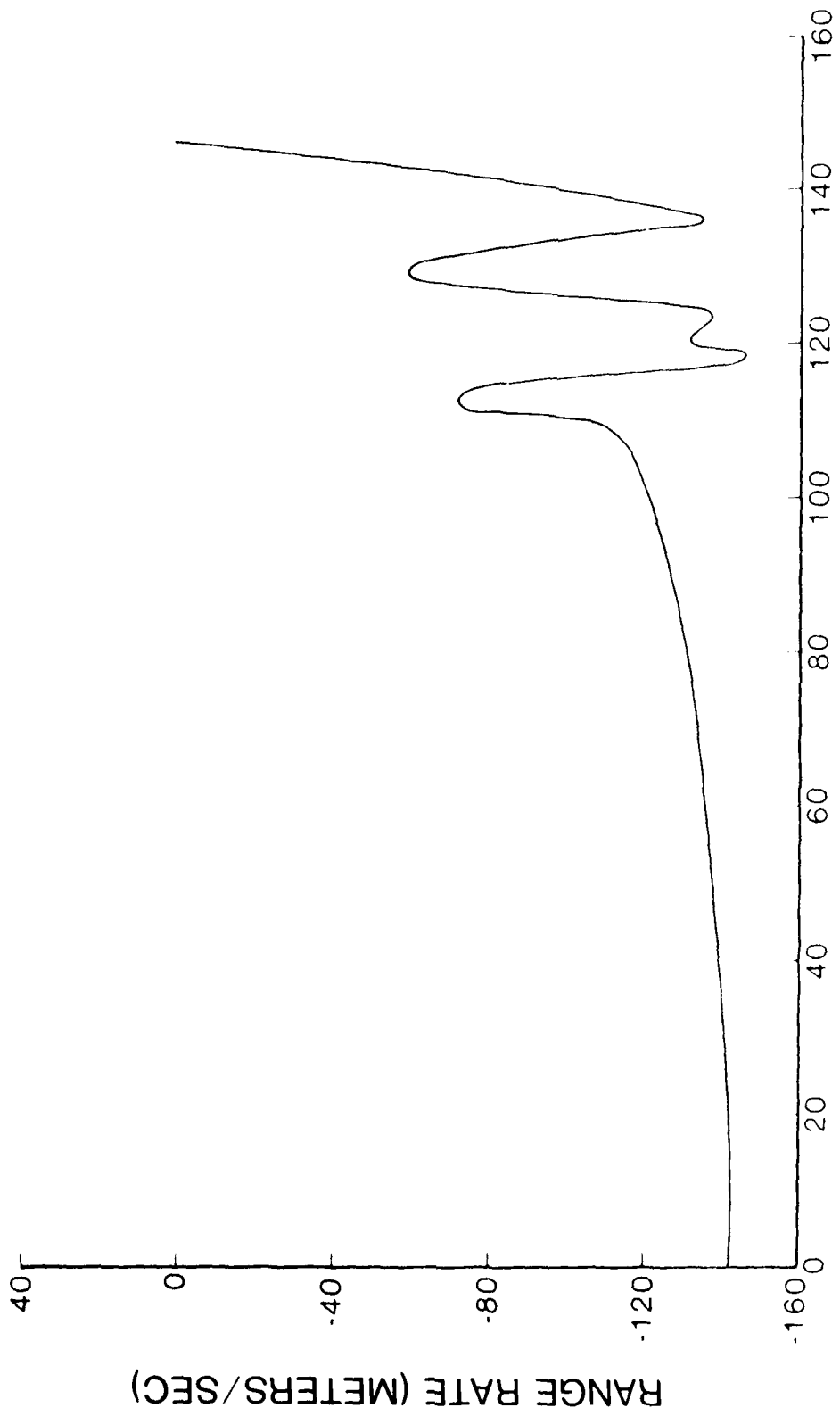

TIME (SEC)
ER ZIG-ZAG

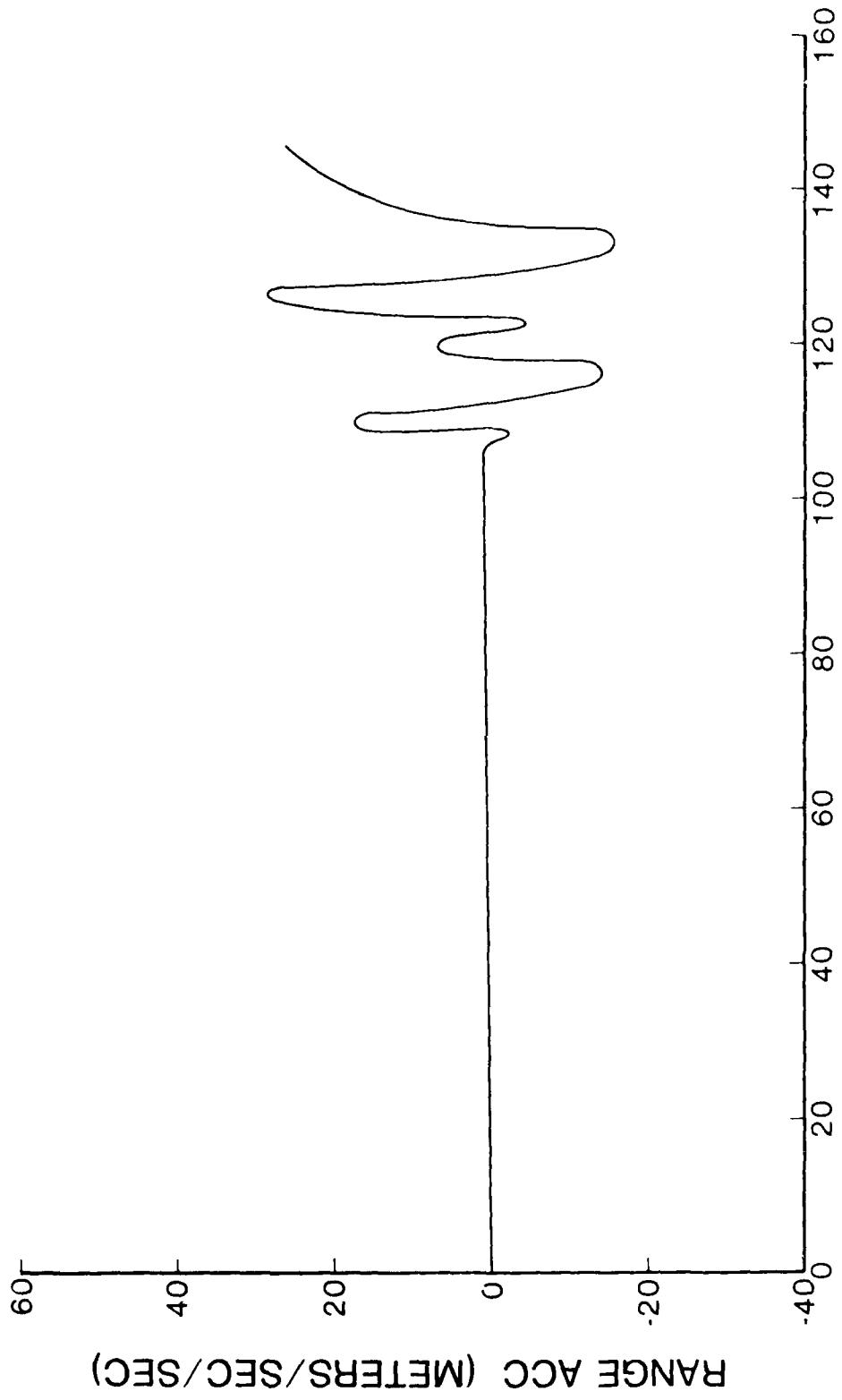

TIME (SEC)
ER ZIG-ZAG

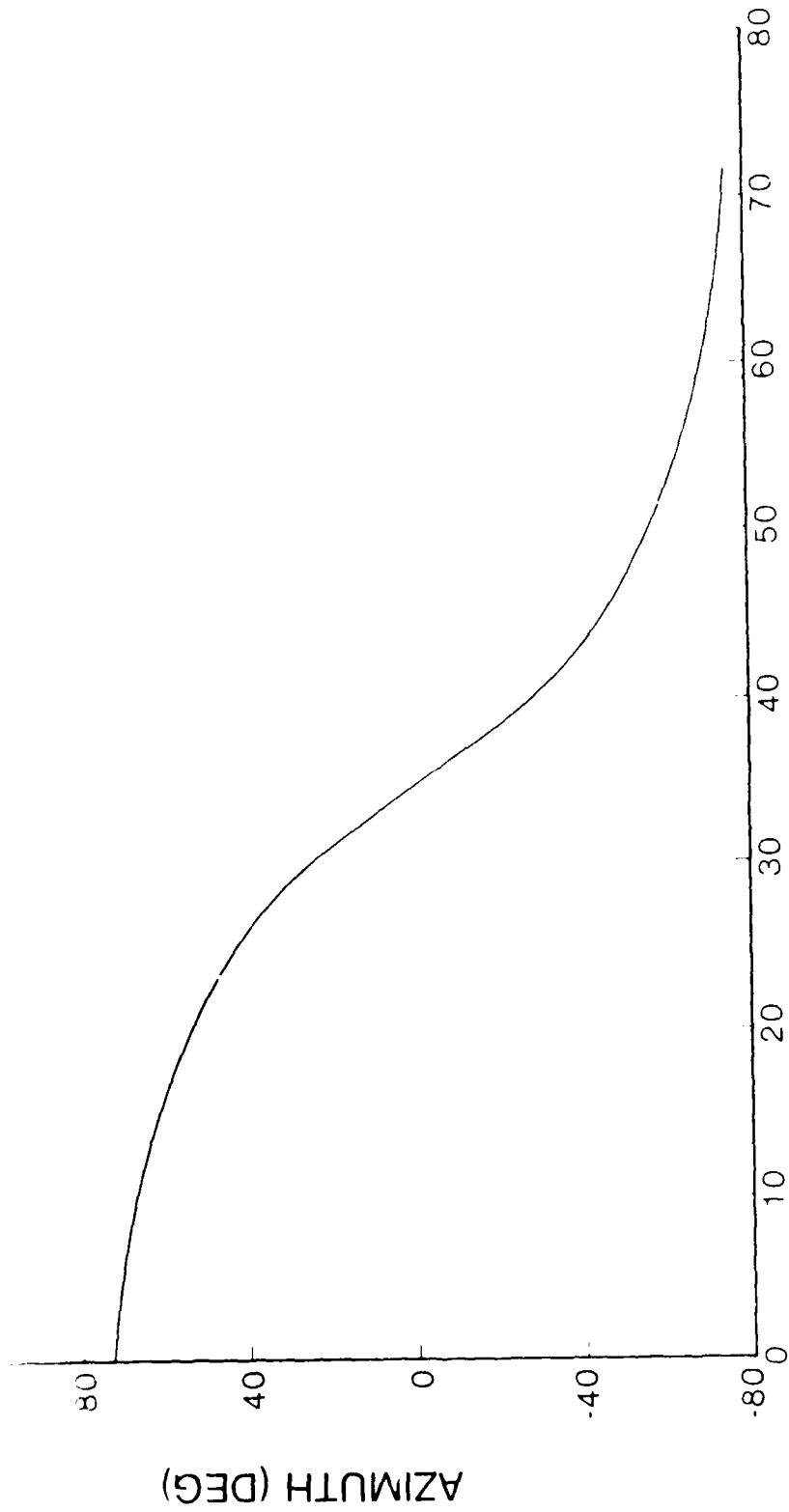

TIME (SEC)

FLYBY 1D

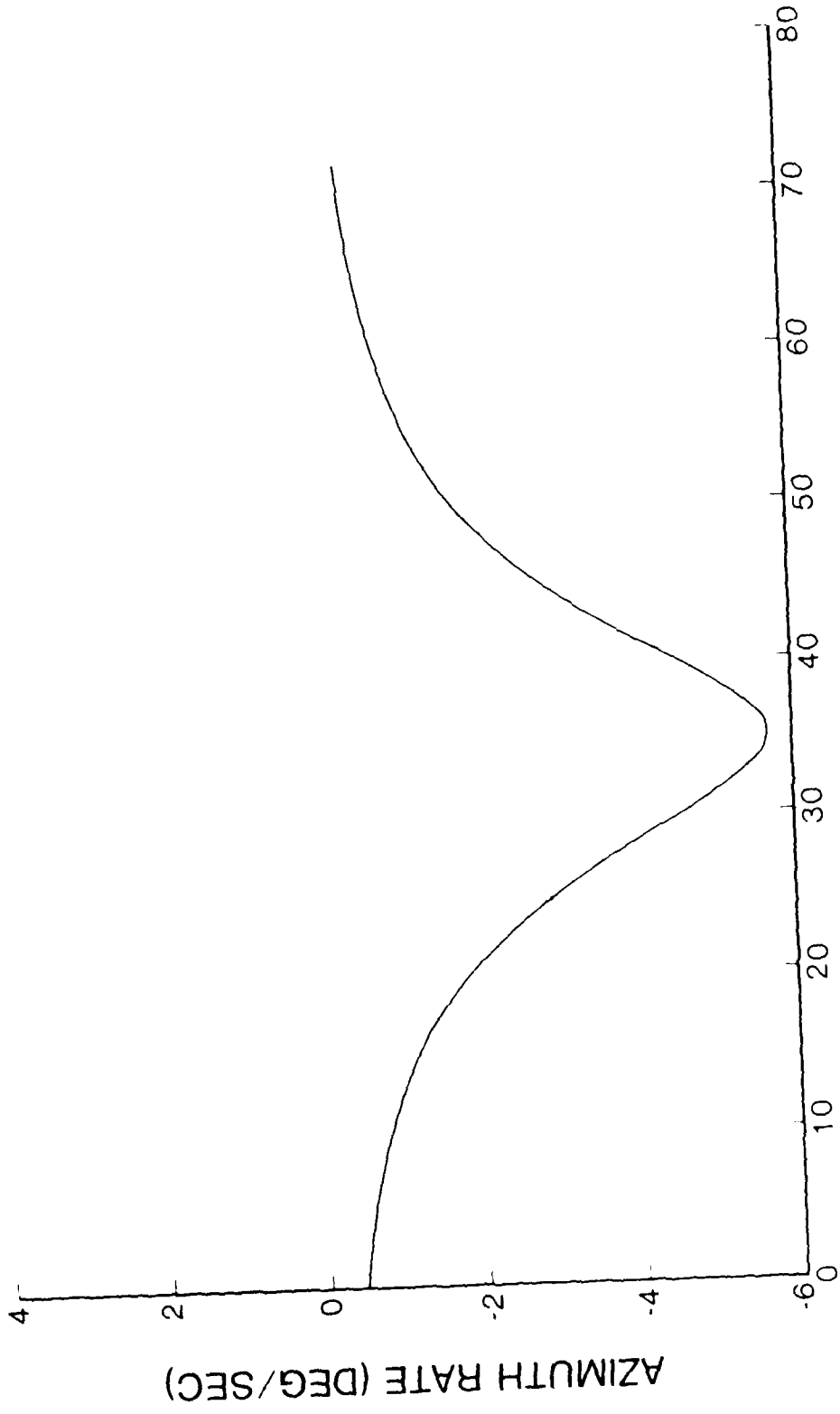

TIME (SEC)
FLYBY 1D

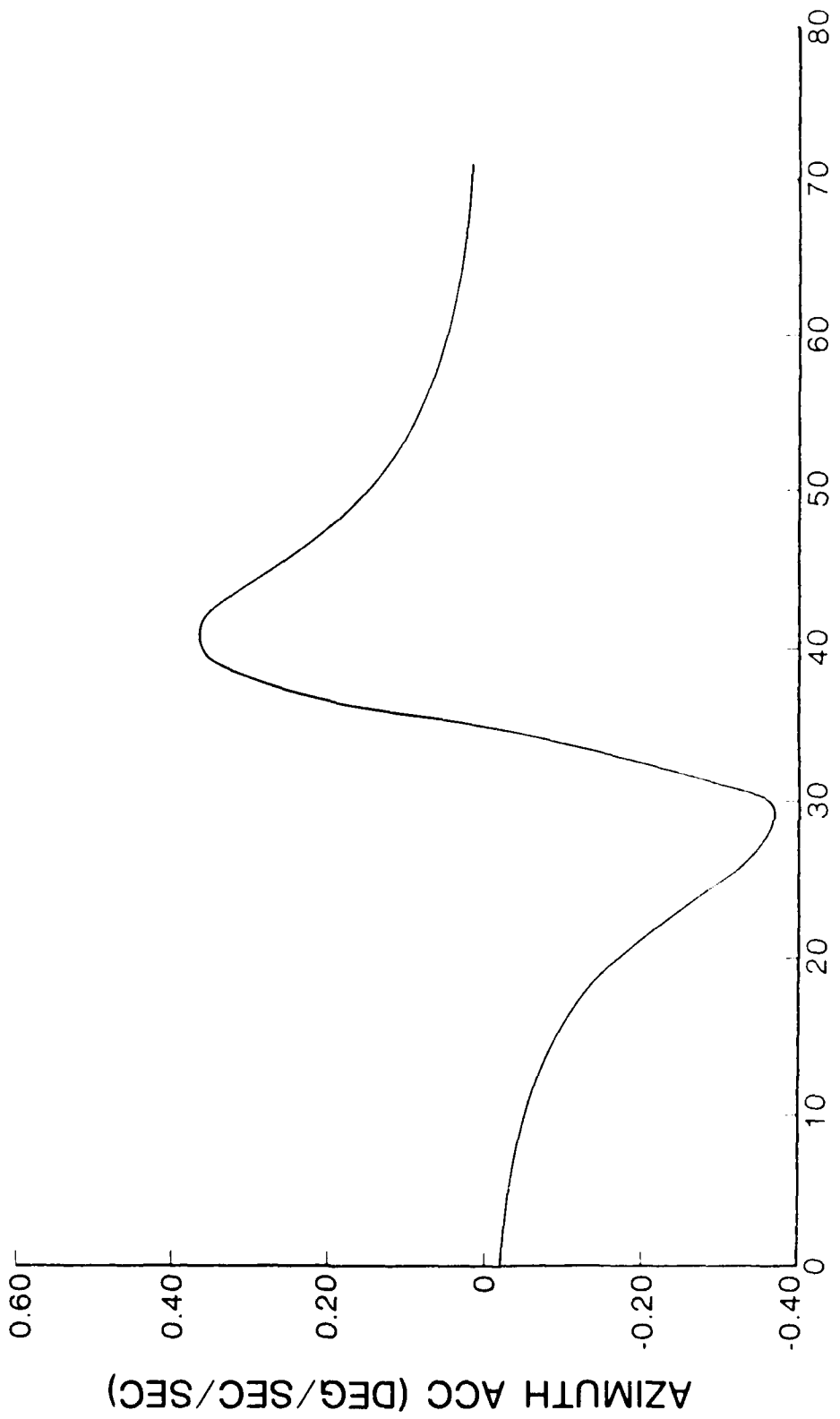

TIME (SEC)
FLYBY 1D

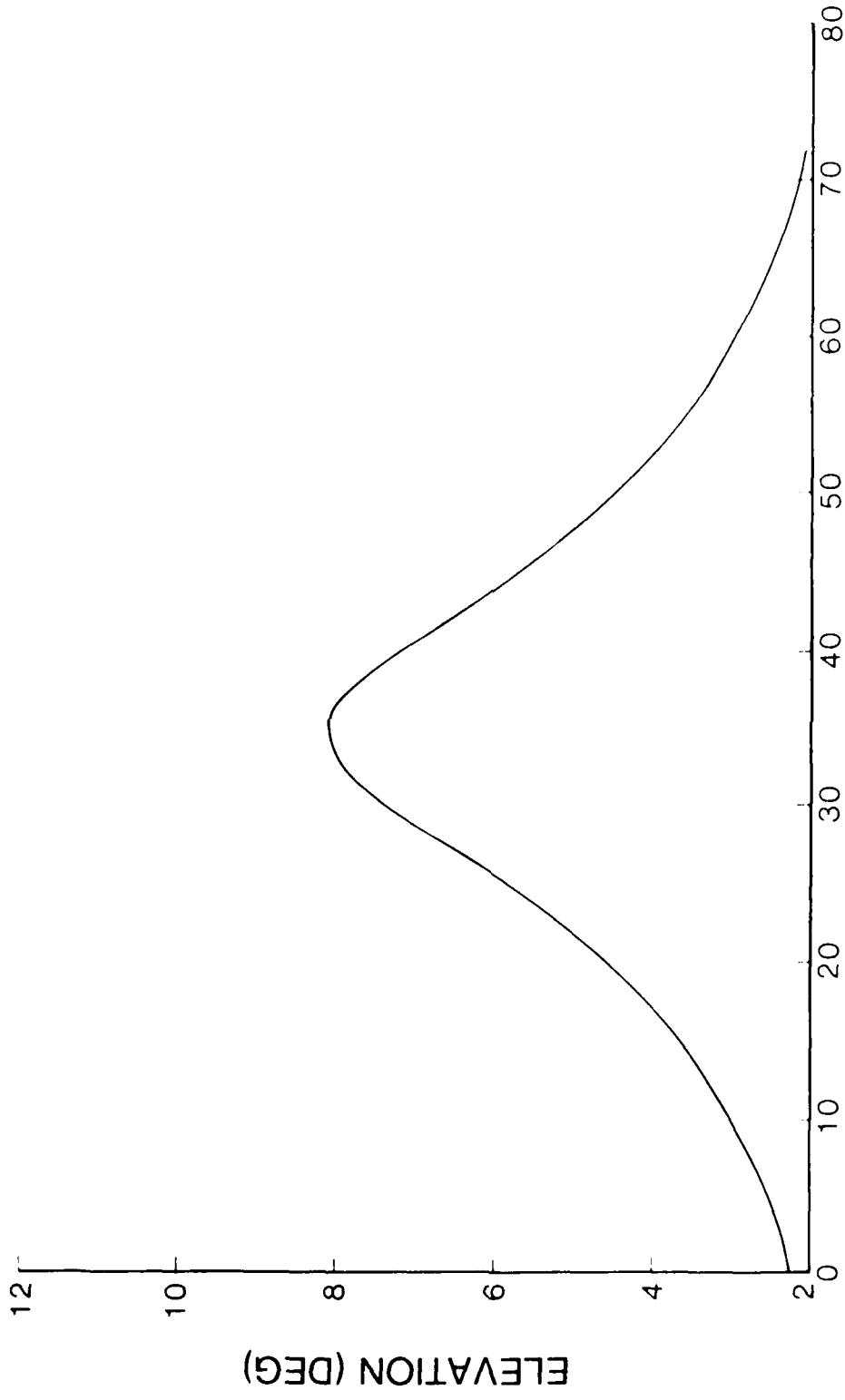

TIME (SEC)
FLYBY 1D

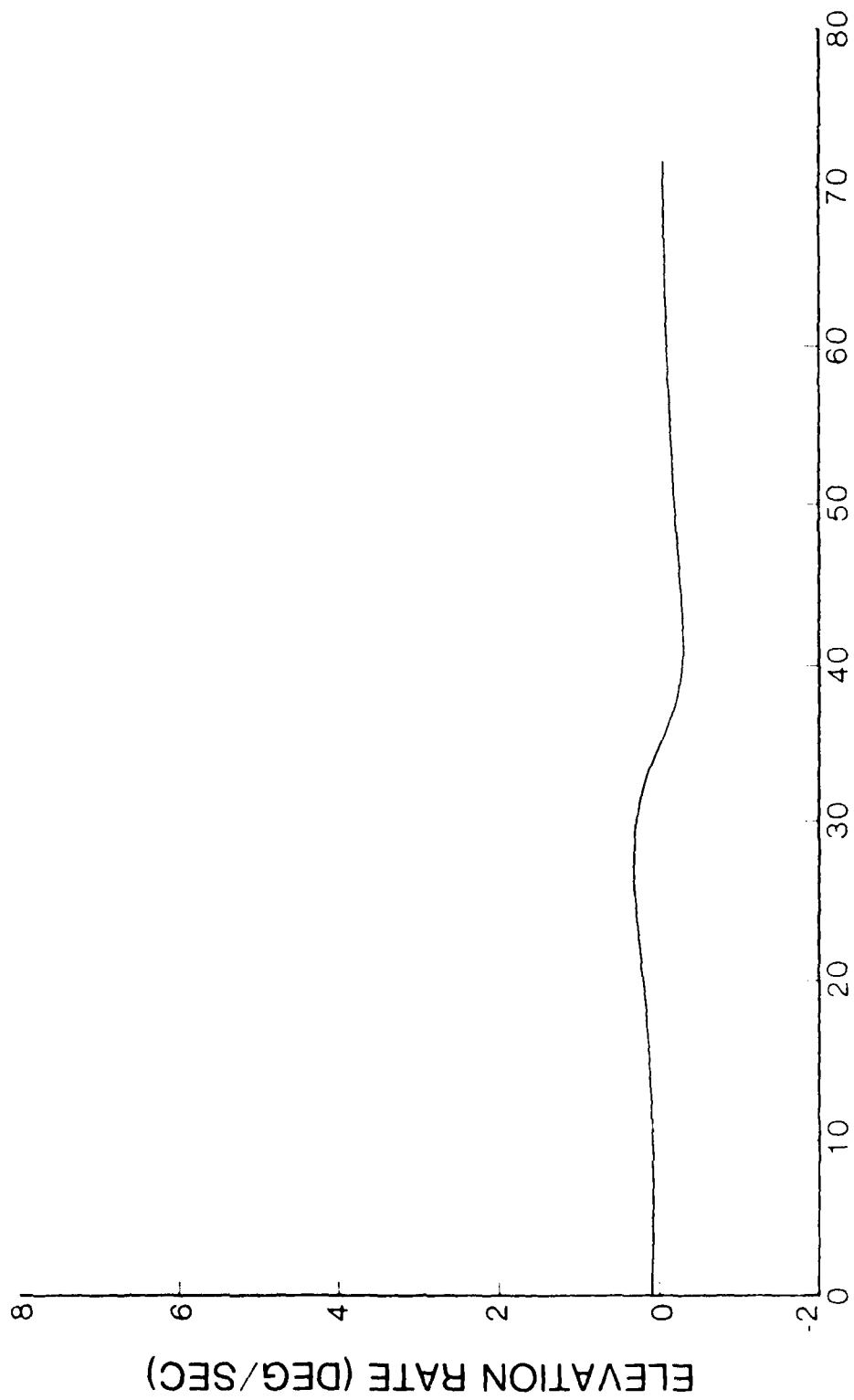

TIME (SEC)
FLYBY 1D

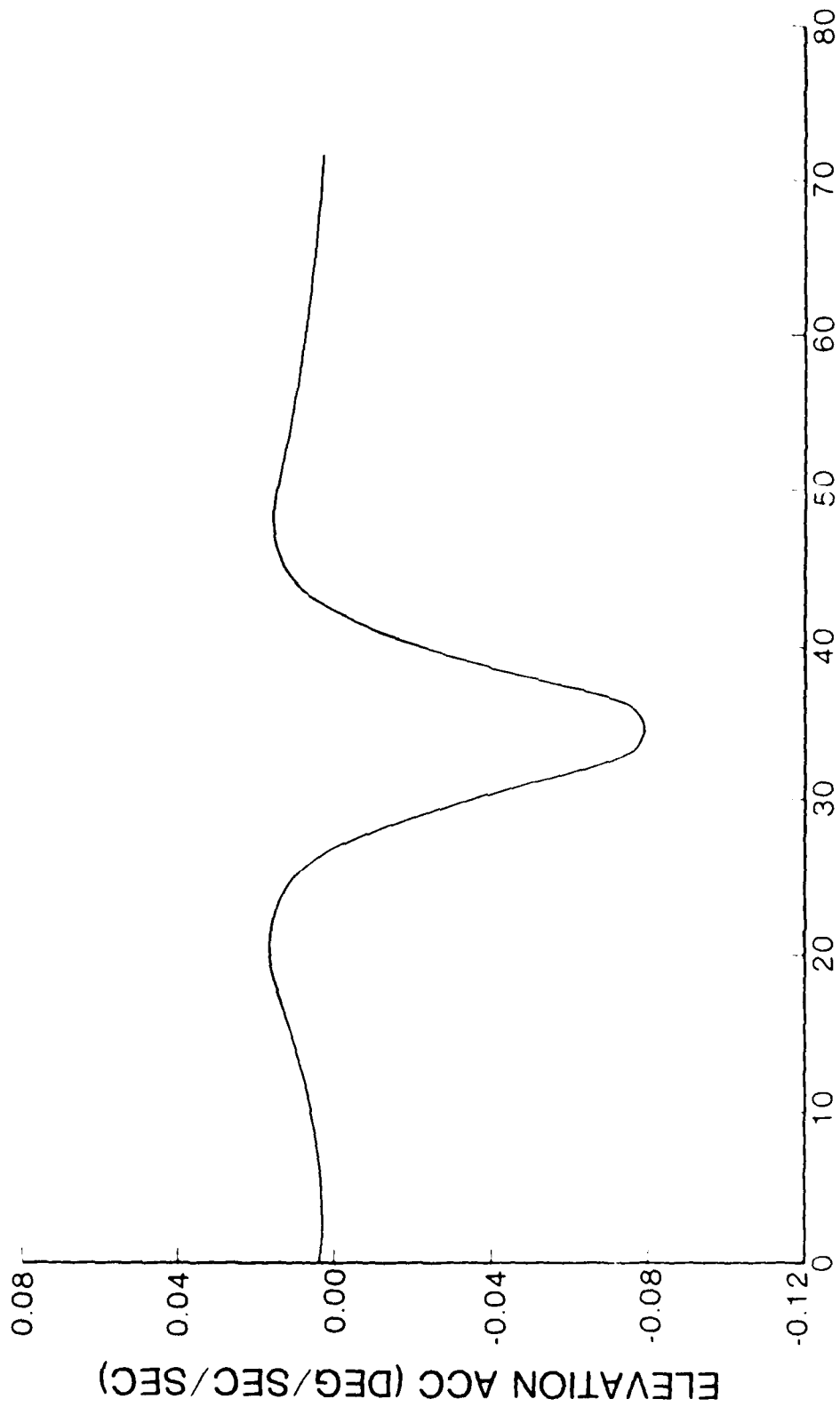

TIME (SEC)

FLYBY 1D

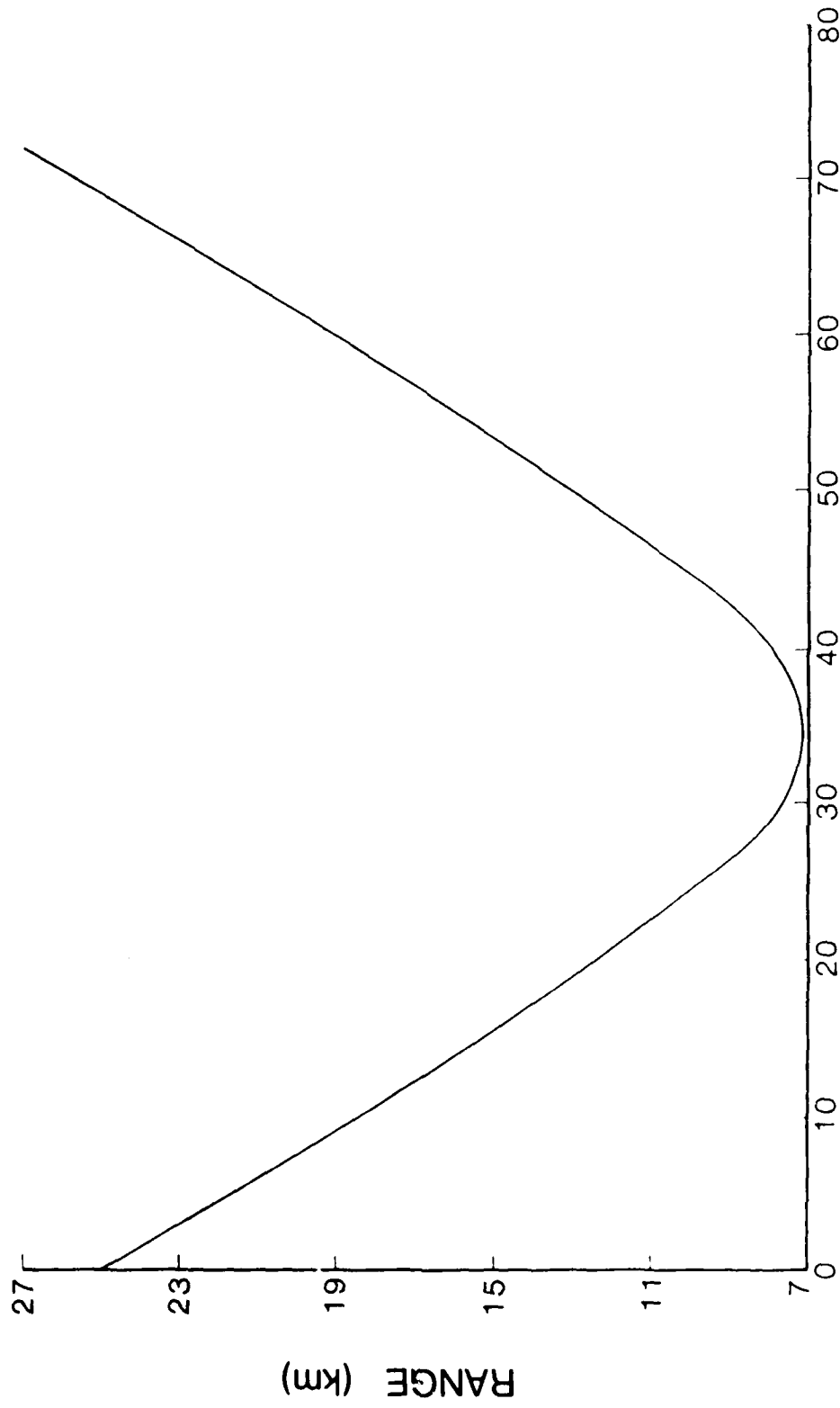

FLYBY 1D

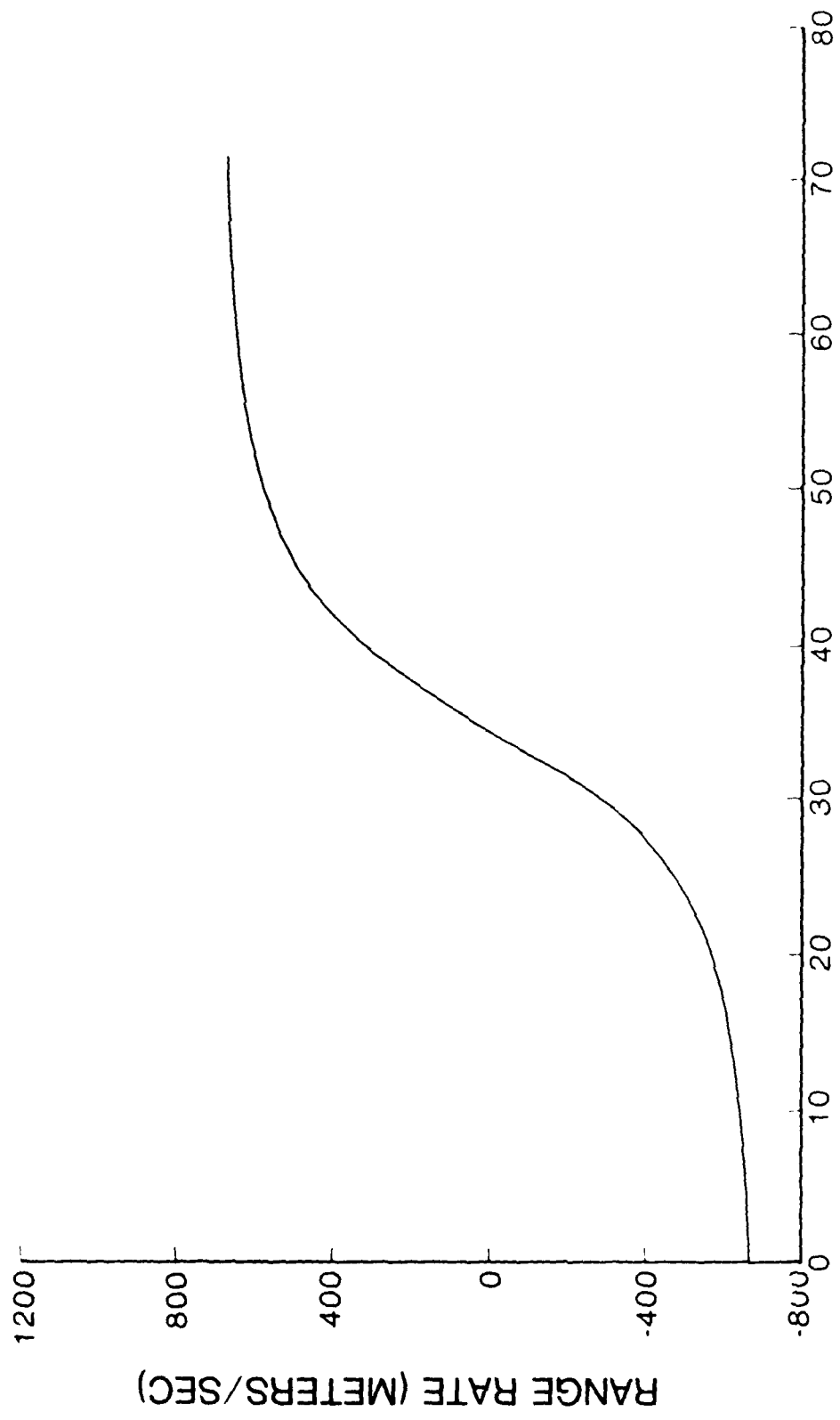

TIME (SEC)
FLYBY 1D

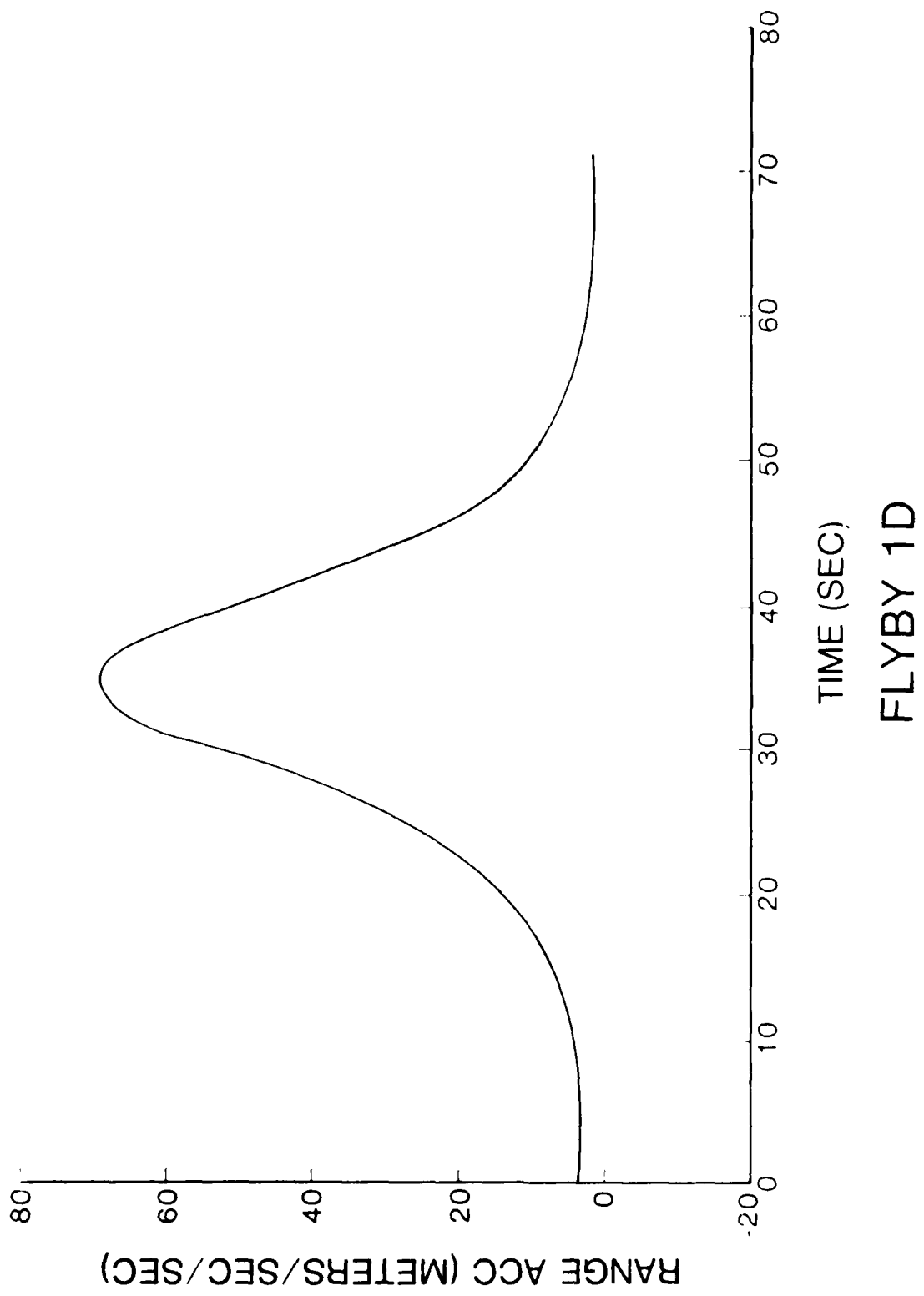

APPENDIX B
SUBJECT CONSENT FORM

Subject Consent for Participation In An Investigation
of Television Tracking Performance as a Function of Aircraft Trajectory

You are invited to participate in a study to determine the effects of various aircraft trajectory characteristics on television tracking performance. We hope to learn which characteristics cause the best performance and which cause the worst. You are invited to participate in this study because you are a member of the SRL subject pool.

If you decide to participate, you will be instructed concerning specific details of your task. You will be tracking simulated aircraft trajectories using either the azimuth or elevation handwheel on the AFAMRL SAM simulator. Four trajectories will be presented to you during each fifty-minute session. You will track for two sessions per day for approximately six days. There are no known medical hazards associated with this task.

Any information that is obtained with this study and that can be identified with you will remain confidential and will be disclosed only with your permission. If you give your permission by signing this document, we plan to disclose only summary statistical data concerning your performance, with no personal reference to you. You will be paid your regular salary while participating.

Your decision to participate will not prejudice your future relations with SRL. If you decide to participate, you are free to withdraw your consent and to discontinue participation at any time without prejudice.

If you have any questions, we expect you to ask us. If you have any additional questions later, Mr. Evan Rolek or Dr. Diana Nelson (258-3960) will be happy to answer them.

YOU WILL BE GIVEN A COPY OF THIS FORM TO KEEP.

YOU ARE MAKING A DECISION WHETHER OR NOT TO PARTICIPATE. YOUR SIGNATURE INDICATES THAT YOU HAVE DECIDED TO PARTICIPATE HAVING READ THE INFORMATION PROVIDED ABOVE.

Date

AM
PM

Time

Signature

Signature of Witness

Signature of Investigator

Appendix C
SAM SIMULATOR DAILY CALIBRATION CHECKLIST

SAM SIMULATOR DAILY CALIBRATION CHECKLIST

1. Date _____
2. Time _____
3. Hardware Condition:
 - a. Elevation Console (2nd flr) _____
 - b. Azimuth Console (2nd flr) _____
 - c. Video Equipment (3rd flr) _____
4. SAM Console TV Monitor Calibration:
 - a. Elevation Brightness Levels (ft-L)
 - Sky (center of bkg film) _____
 - Ground (center of bkg film) _____
 - Sky (EL = 17°, AZ = 67°, darkest area) _____
 - Aircraft at 100% Atmospheric Transmission _____
 - b. Azimuth Brightness Levels (ft-L)
 - Sky (center of bkg film) _____
 - Ground (center of bkg film) _____
 - Sky (EL = 17°, AZ = 67°, darkest area) _____
 - Aircraft at 100% Atmospheric Transmission _____
5. Boresight/Aircraft Alignment _____
6. Tracking Error Detection and Scoring _____
7. Strip Chart Comparison:

MAC-580 #1	J18-7+	J18-8+	J18-9+	J11-7+	J18-10+
Channel #	1	2	3	4	5
	EL	EL	EL	EL	AZ
	Hd.Wh.	Sight	Sight	Error	Hd.Wh.
	Input	Pos	Rate	Signal	Input
	(.05	(Com-	(Com-	Output	(.05
	V/Line)	puted)	puted)	(0.5	V/Line)
		(0.5	(0.5	V/Line)	
		V/Line)	V/Line)		

J18-11+	J18-12+	J11-3+
6	7	8
AZ	AZ	AZ
Sight	Sight	Error
Pos	Rate	Signal
(Com-	(Com-	Output
puted)	puted)	(.05
(0.5	(.05	V/Line)
V/Line)	V/Line)	

Appendix D
ENSEMBLE TRACKING ERROR PLOTS

Note:

- (1) Condition number: means trajectory number
Subject number: means team number
Err: means error.

- (2) Plots based on 16 replications for Team 1 and 20 replications for Team 4.

- (3) Sign conventions:

Axis	Sign	Interpretations
Azimuth	+	Sight leading target
	-	Sight lagging target
Elevation	+	Sight below target
	-	Sight above target

VARIABLE GZIMUTH (CR 1040)
POSITION 1
WAVE 1

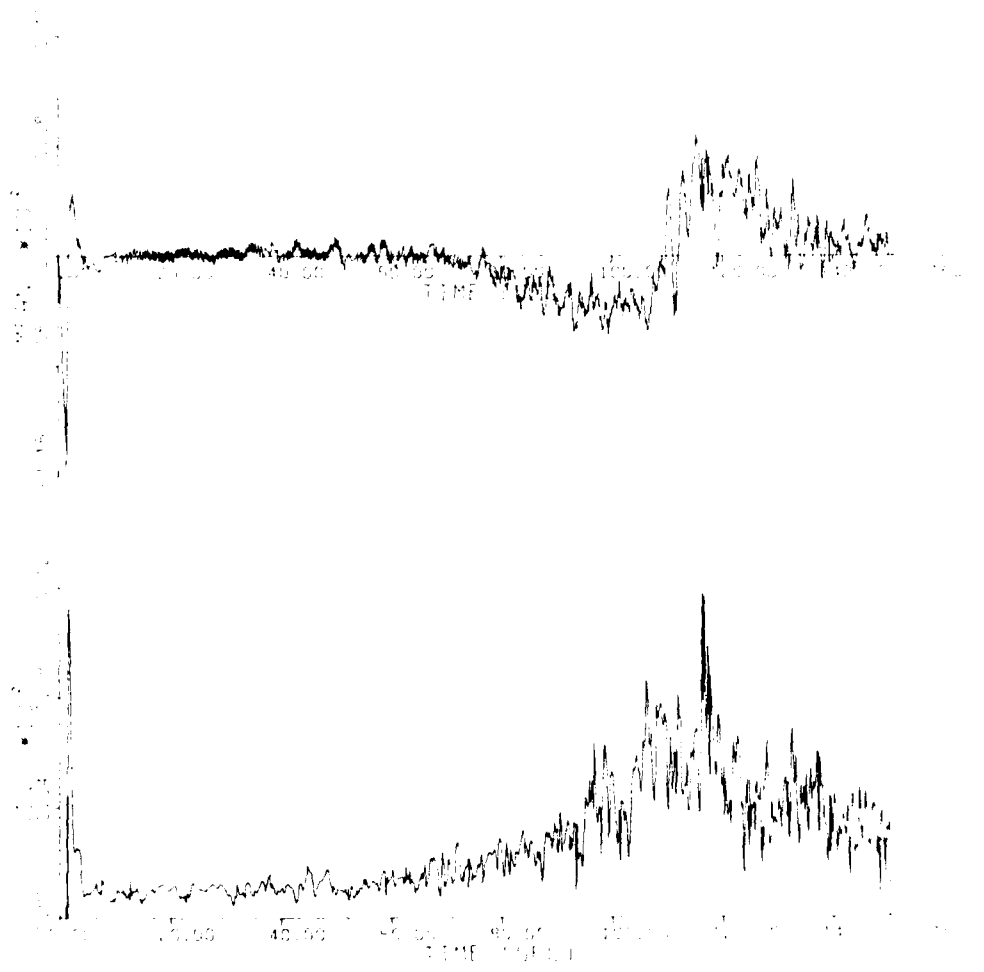

AD-A094 023

SYSTEMS RESEARCH LABS INC DAYTON OHIO F/6 17/7
SAM SYSTEM PERFORMANCE EVALUATION: E-O DATA FOR HUMAN OPERATOR --ETC(U)
NOV 80 E P ROLEK F33615-79-C-0500

UNCLASSIFIED

AFANRL-TR-80-118

NL

2 of 2

NOV 80

END

DATE

PRICE

2.8

DTIC

VARIABLE ELEVATION (PP (RAI))
CONDITION 1
SUBJECT 1

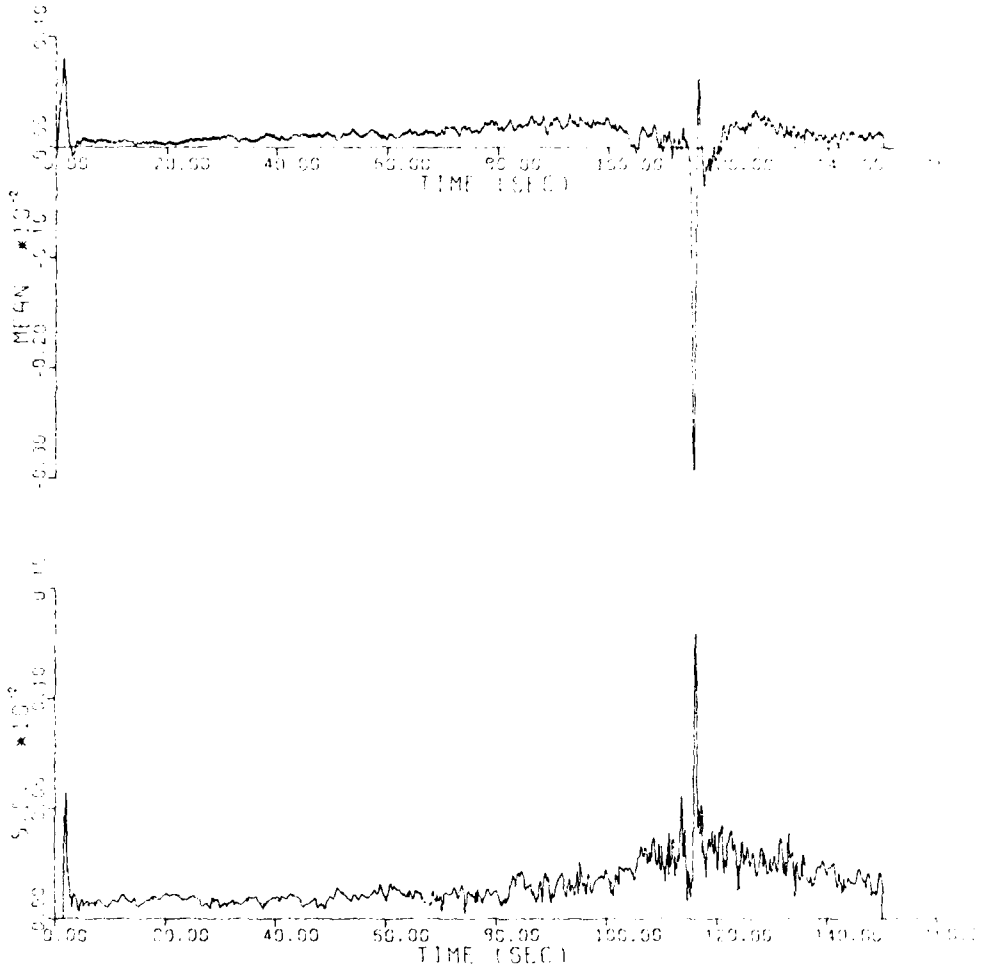

VARIABLE AZIMUTH ERR (RAD)
 CONDITION 2
 SUBJECT 1

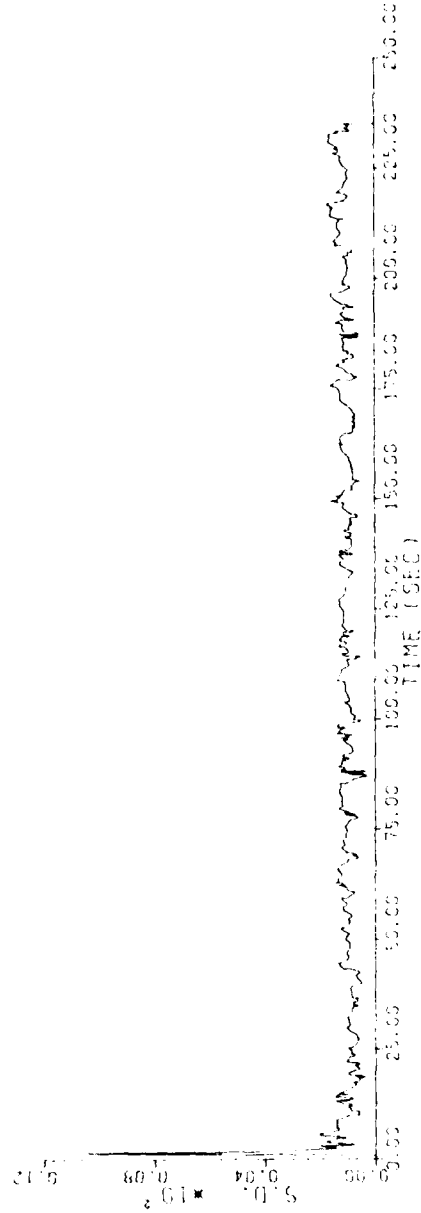

1. 1000
 2. 1000
 3. 1000
 4. 1000
 5. 1000
 6. 1000
 7. 1000
 8. 1000
 9. 1000
 10. 1000
 11. 1000
 12. 1000
 13. 1000
 14. 1000
 15. 1000
 16. 1000
 17. 1000
 18. 1000
 19. 1000
 20. 1000
 21. 1000
 22. 1000
 23. 1000
 24. 1000
 25. 1000
 26. 1000
 27. 1000
 28. 1000
 29. 1000
 30. 1000
 31. 1000
 32. 1000
 33. 1000
 34. 1000
 35. 1000
 36. 1000
 37. 1000
 38. 1000
 39. 1000
 40. 1000
 41. 1000
 42. 1000
 43. 1000
 44. 1000
 45. 1000
 46. 1000
 47. 1000
 48. 1000
 49. 1000
 50. 1000
 51. 1000
 52. 1000
 53. 1000
 54. 1000
 55. 1000
 56. 1000
 57. 1000
 58. 1000
 59. 1000
 60. 1000
 61. 1000
 62. 1000
 63. 1000
 64. 1000
 65. 1000
 66. 1000
 67. 1000
 68. 1000
 69. 1000
 70. 1000
 71. 1000
 72. 1000
 73. 1000
 74. 1000
 75. 1000
 76. 1000
 77. 1000
 78. 1000
 79. 1000
 80. 1000
 81. 1000
 82. 1000
 83. 1000
 84. 1000
 85. 1000
 86. 1000
 87. 1000
 88. 1000
 89. 1000
 90. 1000
 91. 1000
 92. 1000
 93. 1000
 94. 1000
 95. 1000
 96. 1000
 97. 1000
 98. 1000
 99. 1000
 100. 1000

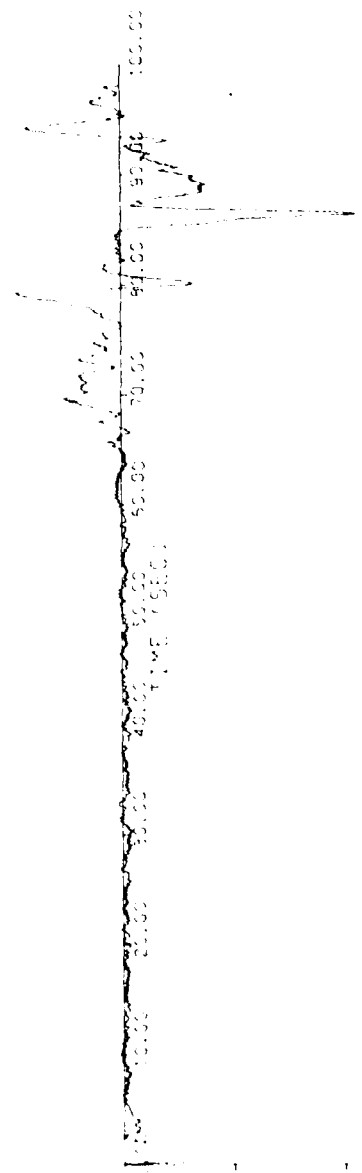

1000
900
800
700
600
500
400
300
200
100
0

10

0.75

0.04

0.00

0.00

0.00

0.00

0.00

0.00

0.00

0.00

0.00

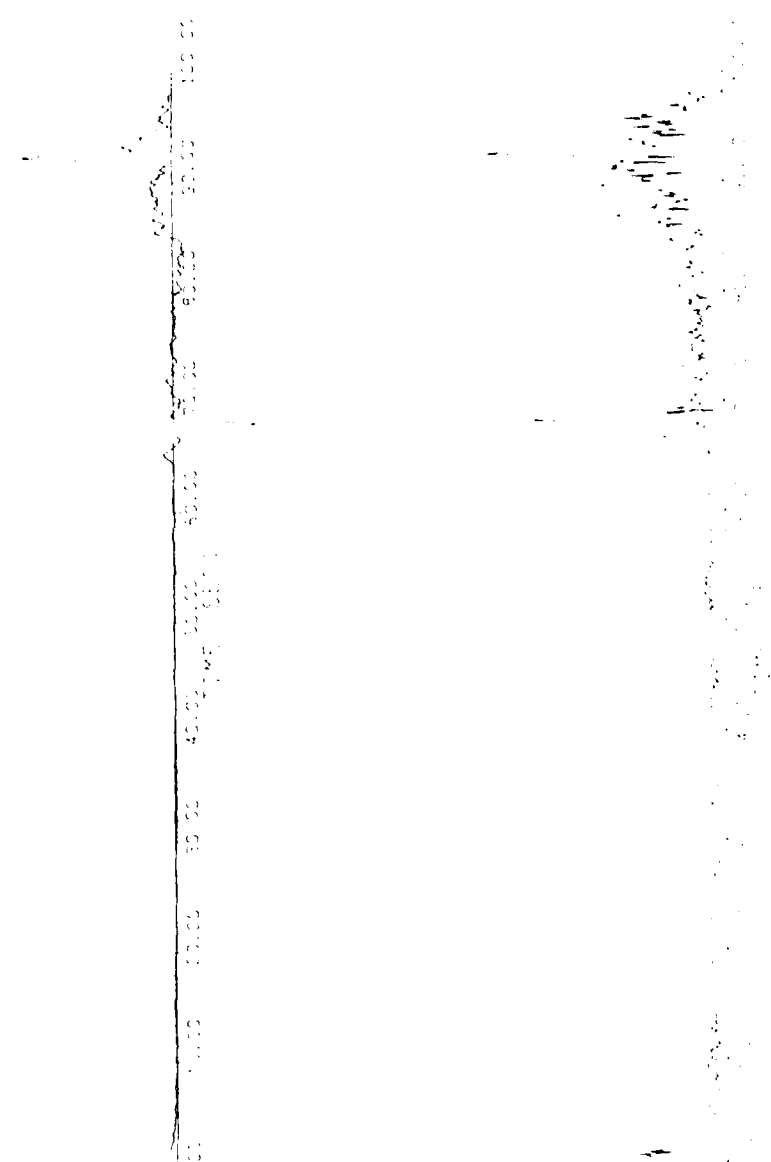

1000000
 500000
 0
 MEAN

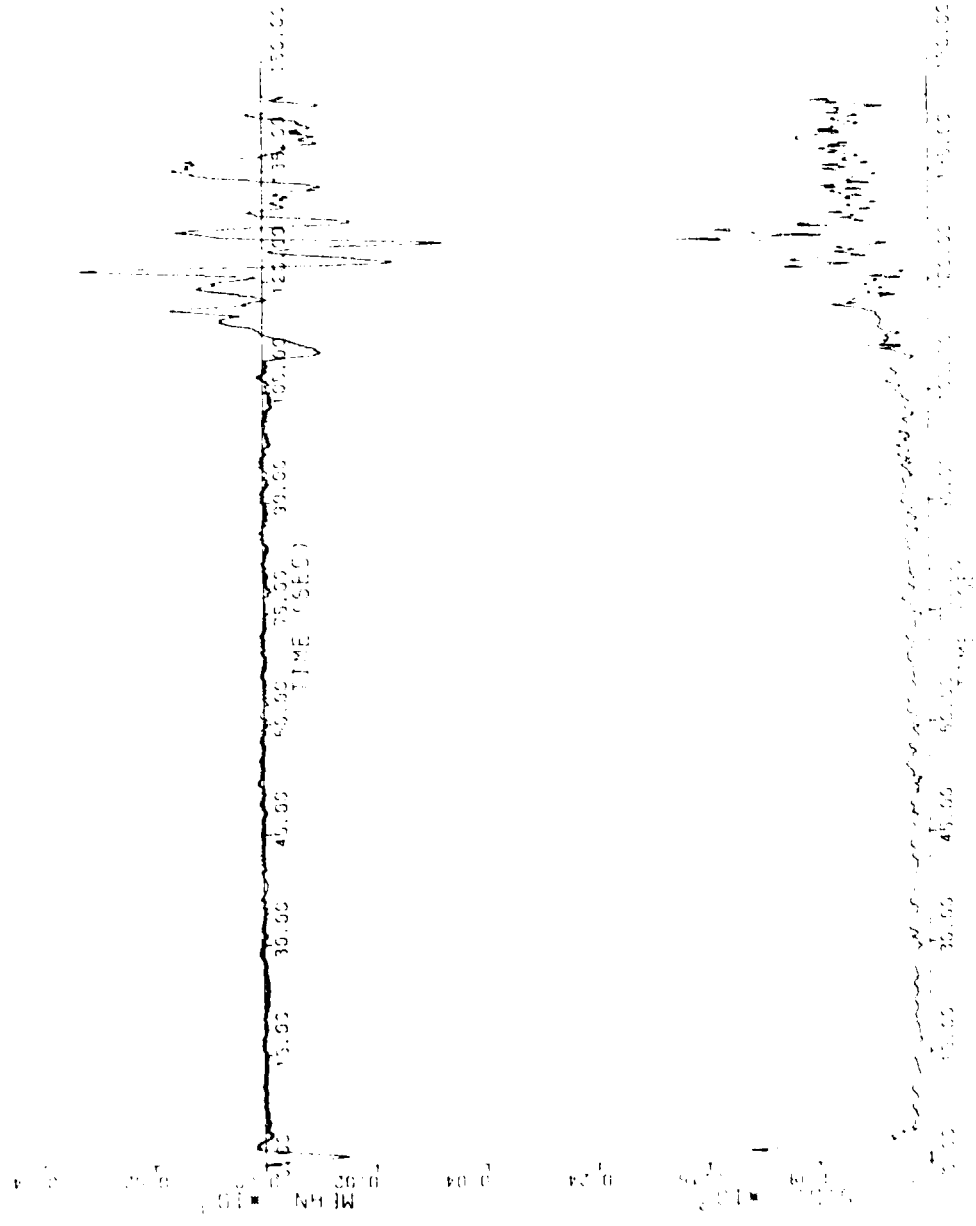

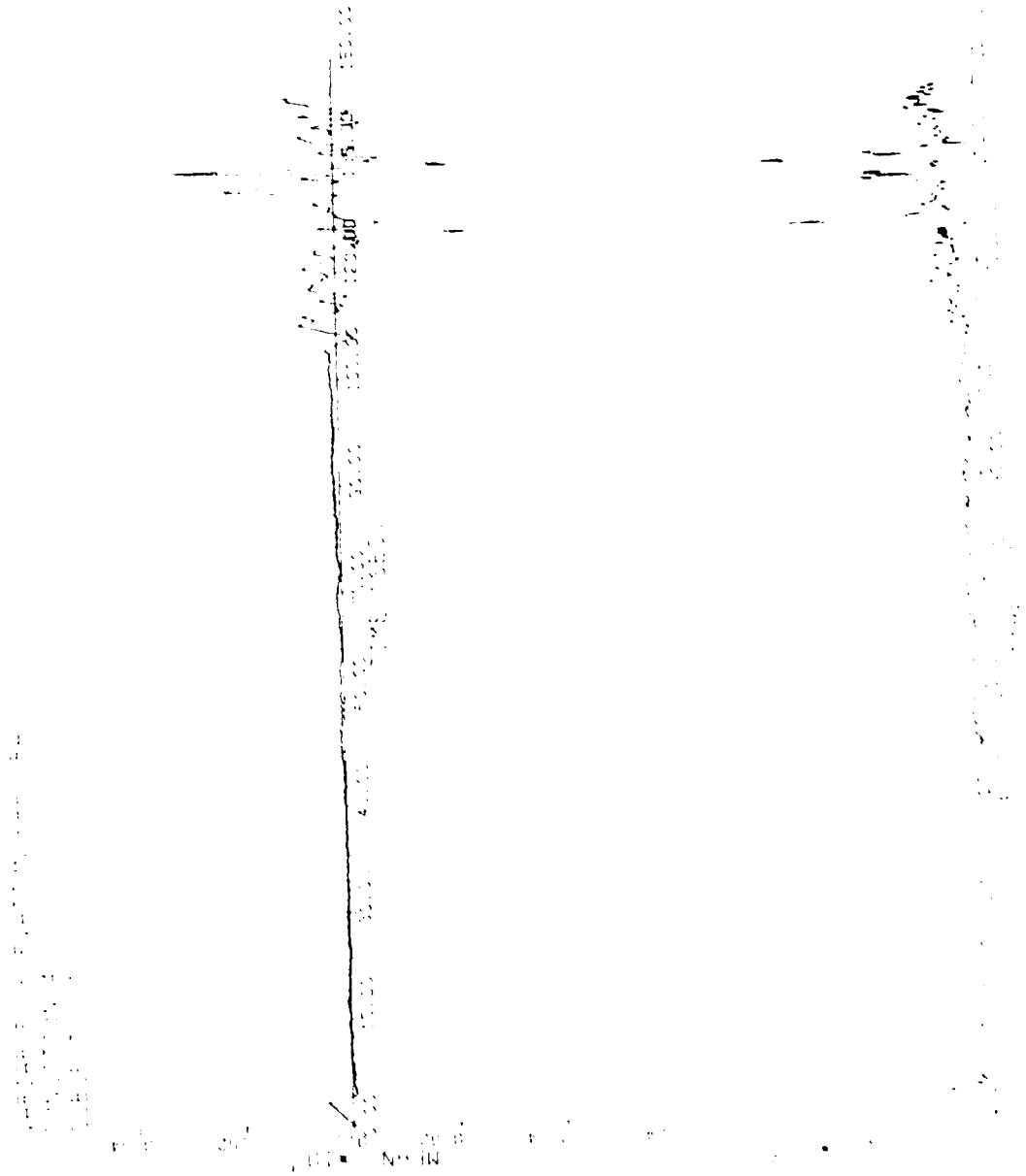
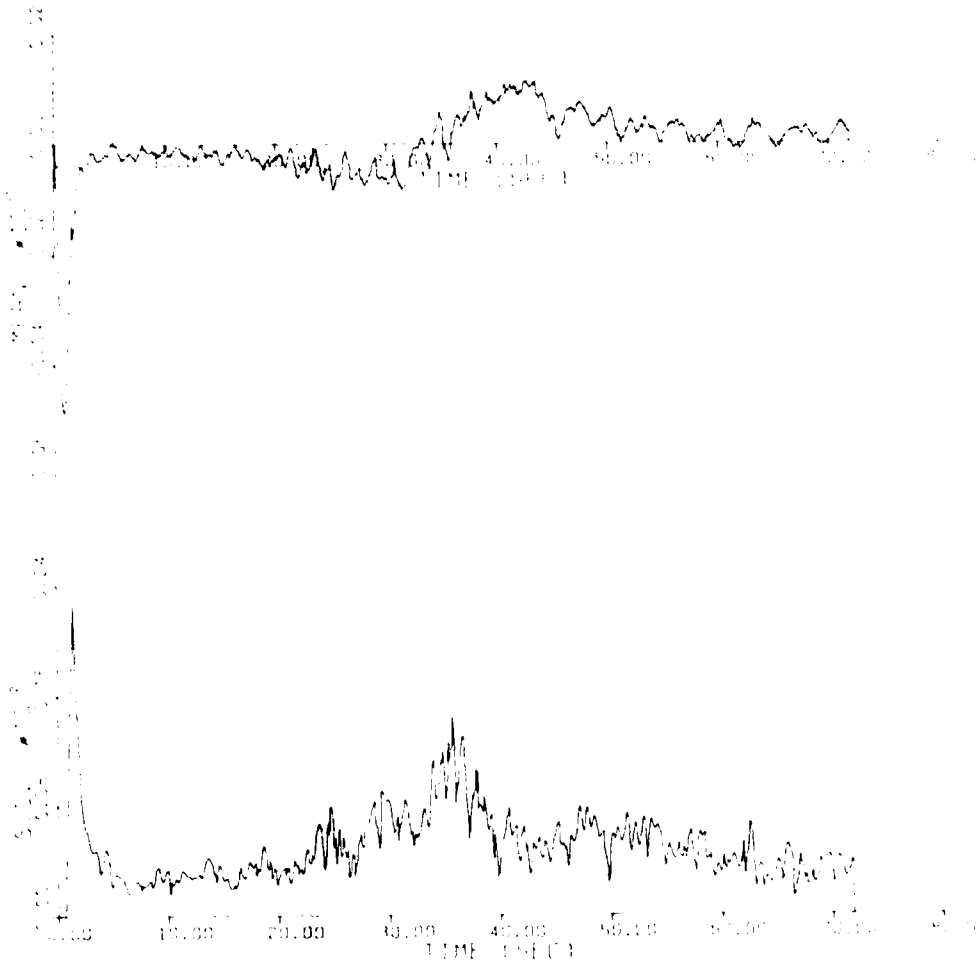
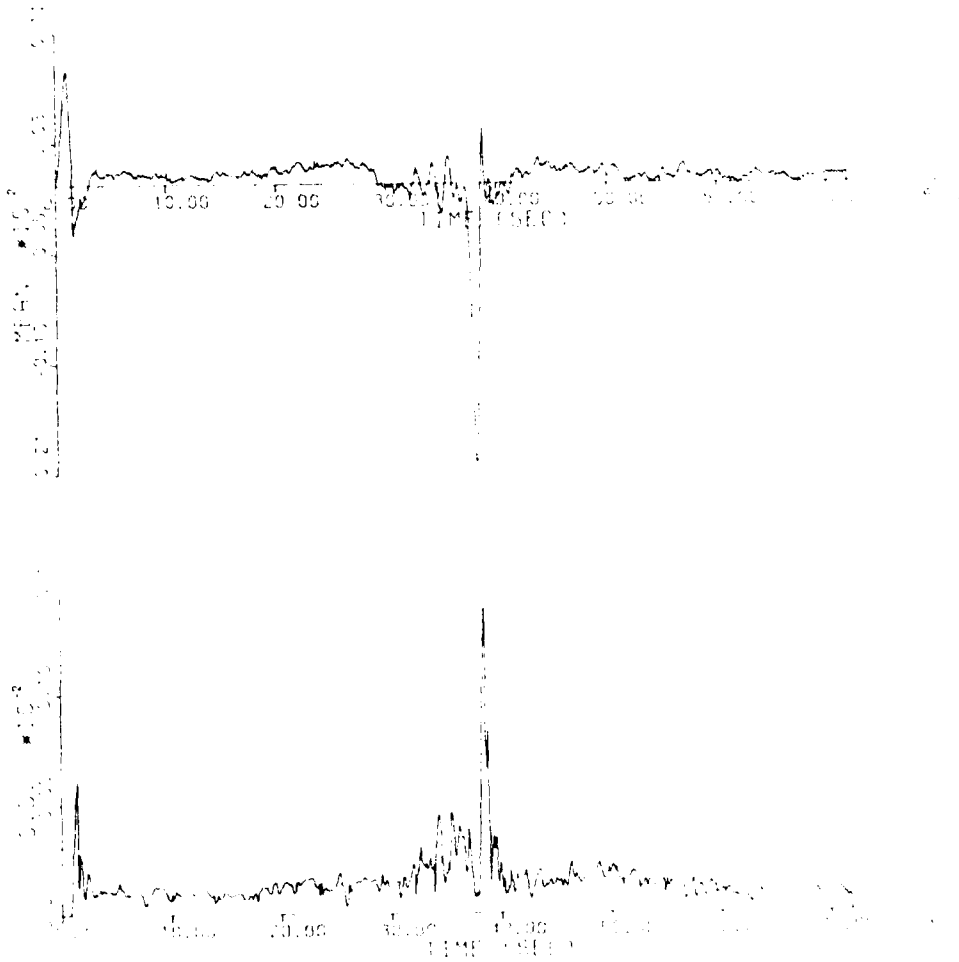

TABLE AZIMUTH ERR (RM)
CONDITION 5
CORRECT 1



PRIOR ELEVATION ERR (RAD)
CONDITION 5
SUBJECT 1



UNCLASSIFIED INFORMATION
EXEMPTION 1
SUBJECT 4

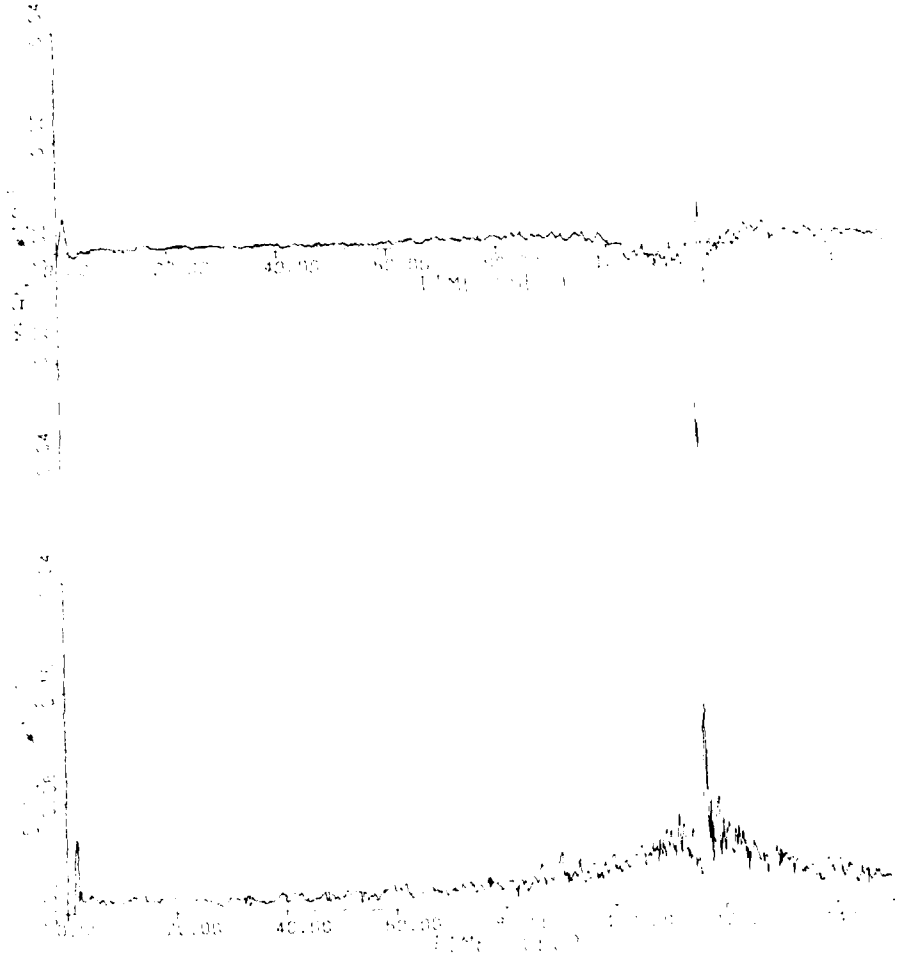

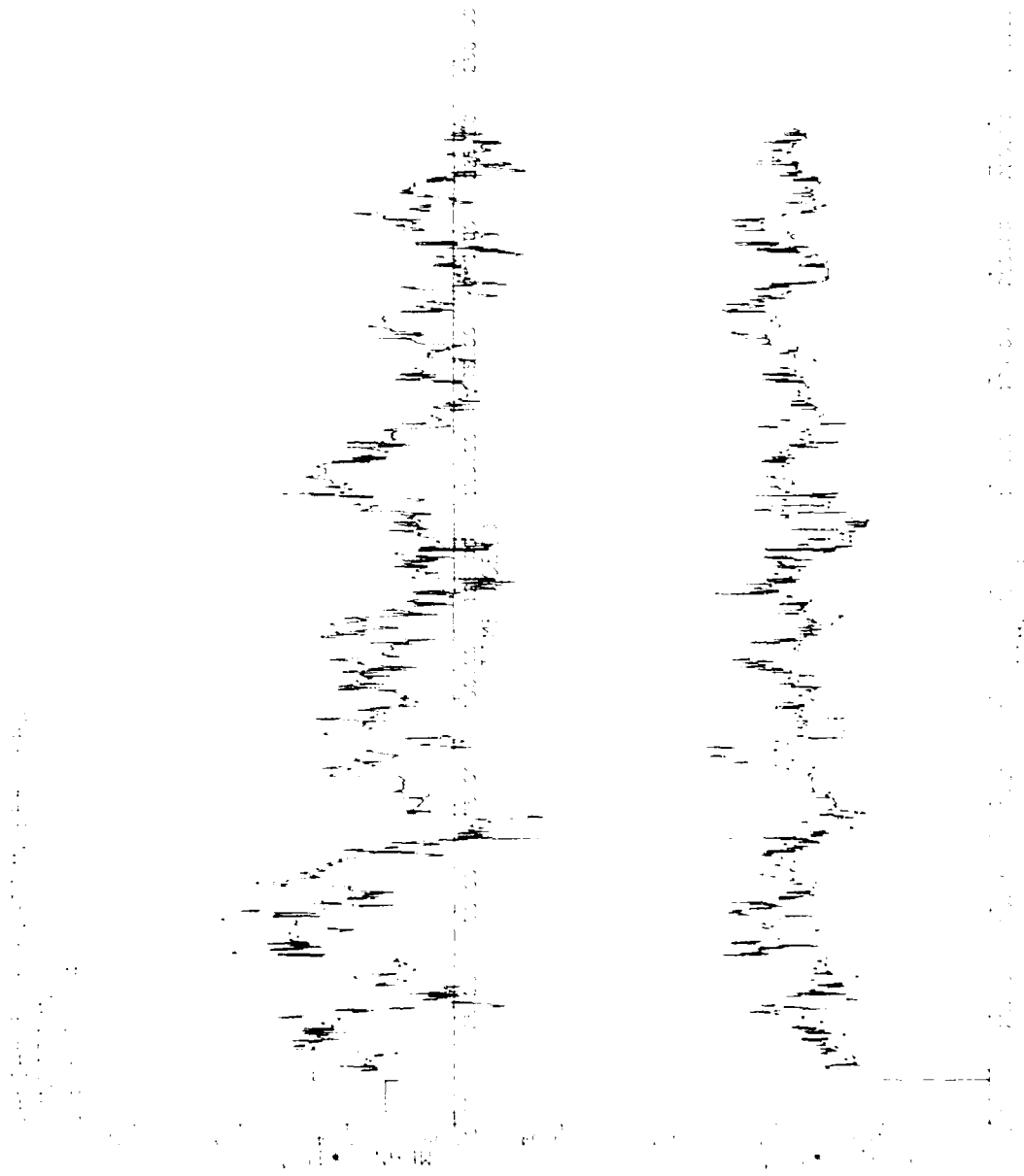

11.00
11.05
11.10
11.15
11.20
11.25
11.30
11.35
11.40
11.45
11.50
11.55
12.00



96.0 50.0 31.0 10.0
2.01 * Nb IN

PERIODIC STIMULI (EEG TRACES)
CONDITION 3
SUBJECT 4

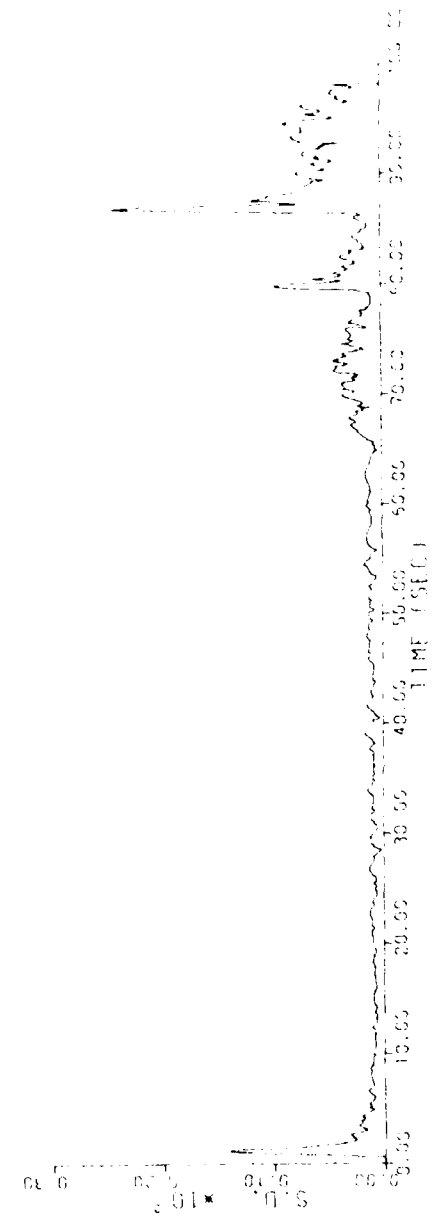
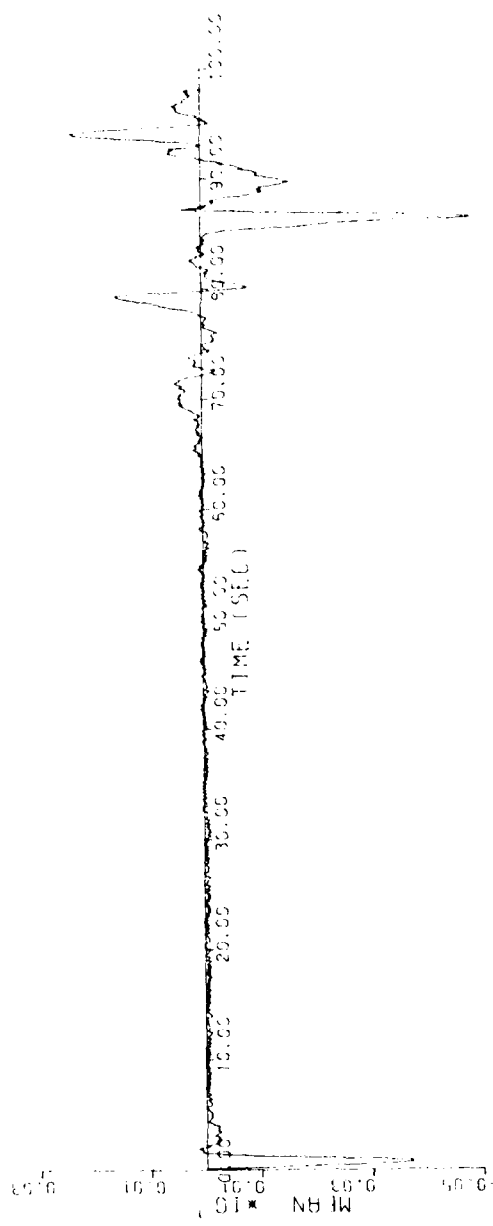

01.00 02.00 03.00 04.00 05.00 06.00 07.00 08.00 09.00 10.00 11.00 12.00 13.00 14.00 15.00 16.00 17.00 18.00 19.00 20.00 21.00 22.00 23.00 24.00 25.00 26.00 27.00 28.00 29.00 30.00 31.00 32.00 33.00 34.00 35.00 36.00 37.00 38.00 39.00 40.00 41.00 42.00 43.00 44.00 45.00 46.00 47.00 48.00 49.00 50.00 51.00 52.00 53.00 54.00 55.00 56.00 57.00 58.00 59.00 60.00 61.00 62.00 63.00 64.00 65.00 66.00 67.00 68.00 69.00 70.00 71.00 72.00 73.00 74.00 75.00 76.00 77.00 78.00 79.00 80.00 81.00 82.00 83.00 84.00 85.00 86.00 87.00 88.00 89.00 90.00 91.00 92.00 93.00 94.00 95.00 96.00 97.00 98.00 99.00 100.00

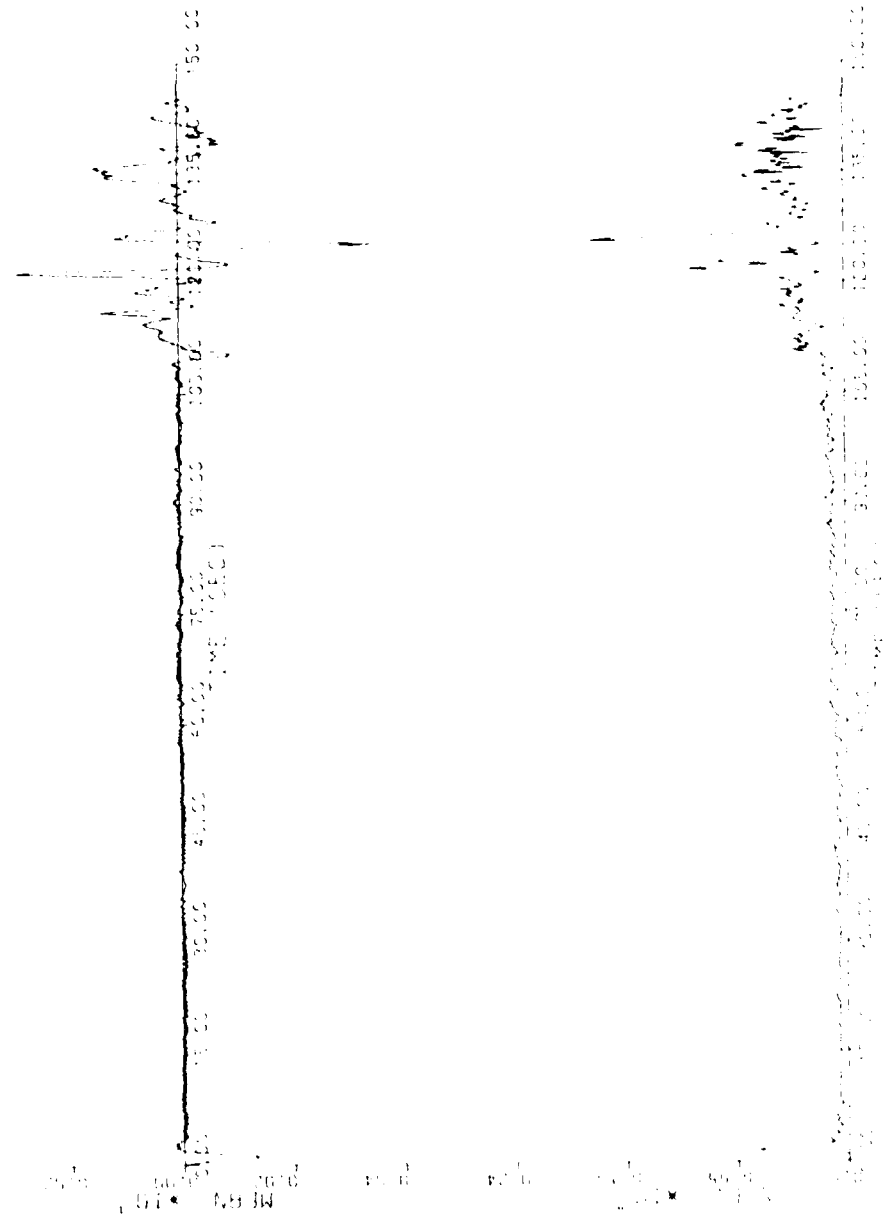

10.00
 11.00
 12.00
 13.00
 14.00
 15.00
 16.00
 17.00
 18.00
 19.00
 20.00
 21.00
 22.00
 23.00
 24.00
 25.00
 26.00
 27.00
 28.00
 29.00
 30.00
 31.00
 32.00
 33.00
 34.00
 35.00
 36.00
 37.00
 38.00
 39.00
 40.00
 41.00
 42.00
 43.00
 44.00
 45.00
 46.00
 47.00
 48.00
 49.00
 50.00
 51.00
 52.00
 53.00
 54.00
 55.00
 56.00
 57.00
 58.00
 59.00
 60.00
 61.00
 62.00
 63.00
 64.00
 65.00
 66.00
 67.00
 68.00
 69.00
 70.00
 71.00
 72.00
 73.00
 74.00
 75.00
 76.00
 77.00
 78.00
 79.00
 80.00
 81.00
 82.00
 83.00
 84.00
 85.00
 86.00
 87.00
 88.00
 89.00
 90.00
 91.00
 92.00
 93.00
 94.00
 95.00
 96.00
 97.00
 98.00
 99.00
 100.00

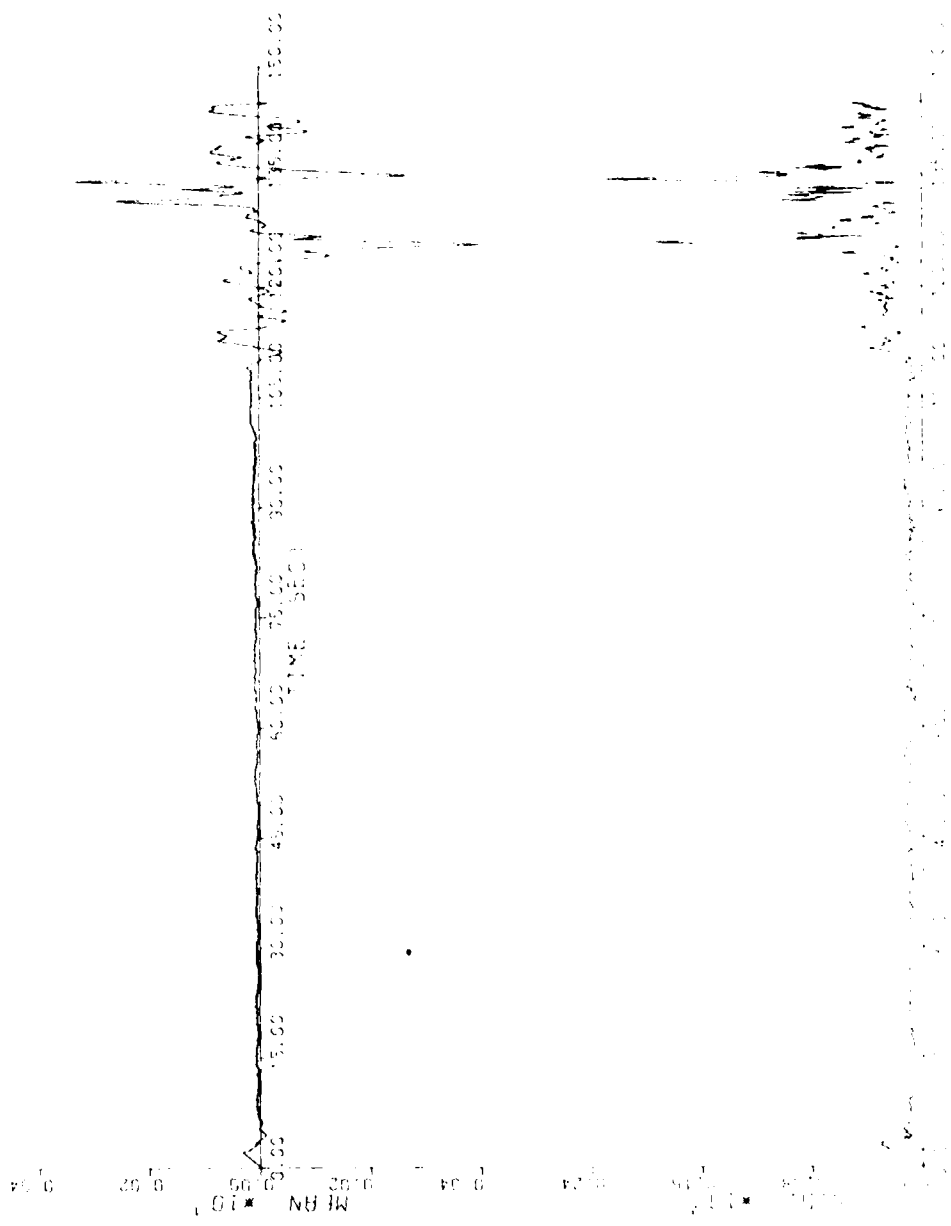

INSTRUMENT: WZM-1000-1000
COMPOUND: 1
SUBJECT: 4

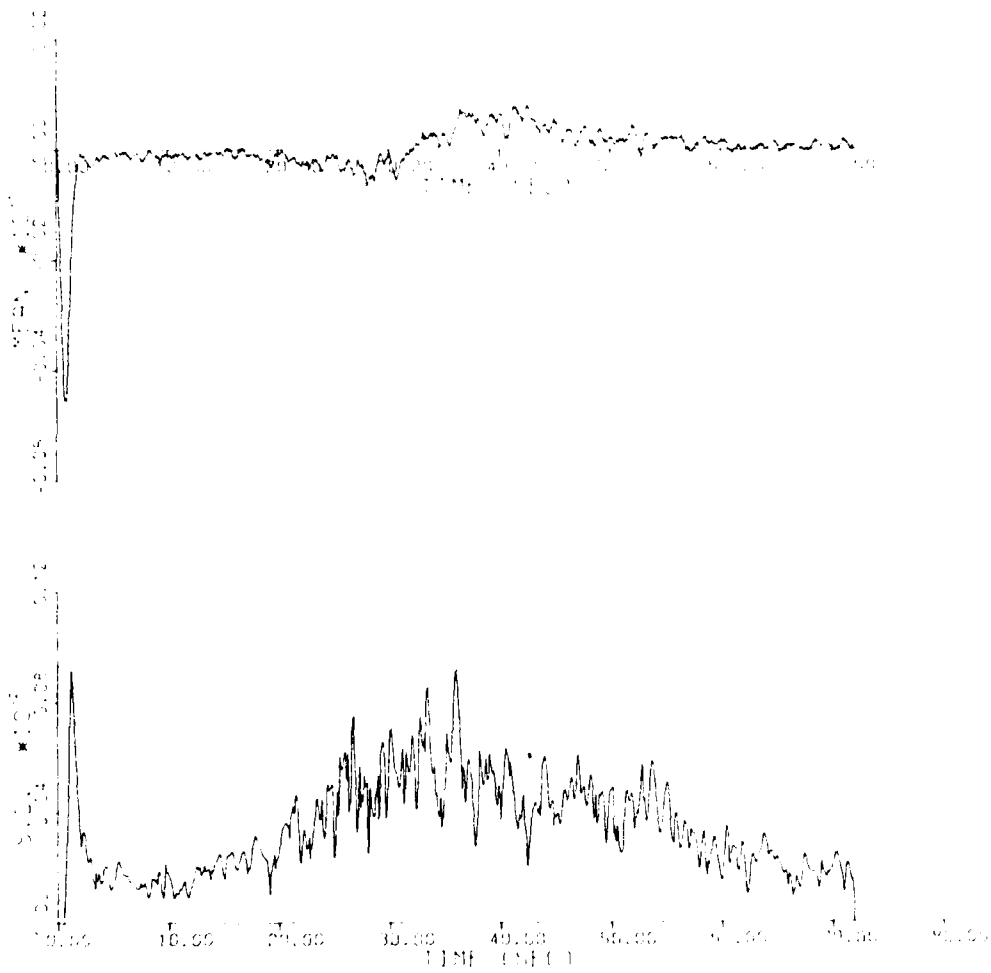

ANGLE OF ELEVATION ERR (RAD)
EXPERIMENT 5
SUBJECT 4

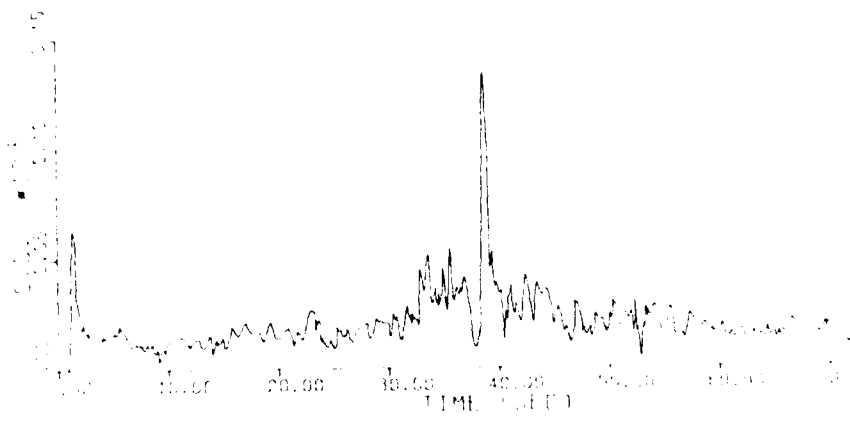
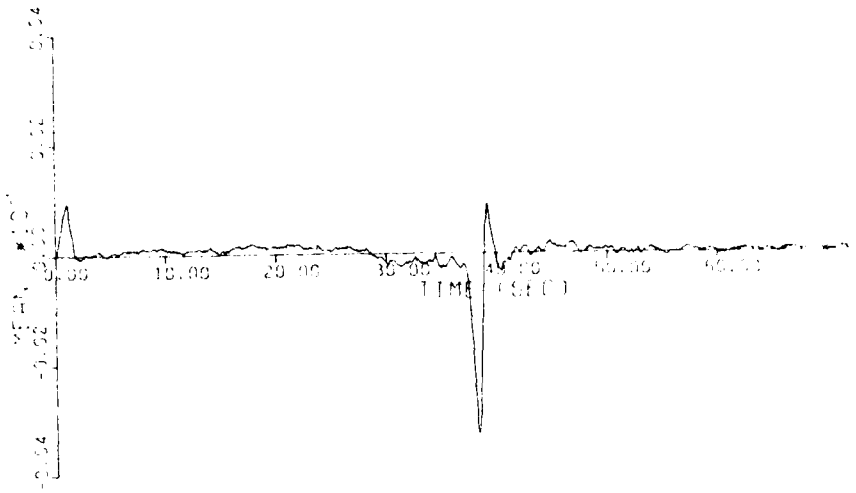

Appendix E
CELL MEANS AND STANDARD DEVIATIONS

CELL MEANS OF RMS AZIMUTH SCORES (mrad)

		Trajectory				
		FLYBY 1B 1	SLOW 5A 2	ER S-PASS 3	ER ZIG-ZAG 4	FLYBY 1D 5
TEAM	1	.551	.343	.858	.694	.986
	4	.447	.304	.785	.552	.779

CELL STANDARD DEVIATIONS RMS AZIMUTH SCORES (mrad)

		Trajectory				
		FLYBY 1B 1	SLOW 5A 2	ER S-PASS 3	ER ZIG-ZAG 4	FLYBY 1D 5
TEAM	1	.044	.034	.053	.055	.115
	4	.033	.043	.078	.034	.050

CELL MEANS OF RMS ELEVATION SCORES (mrad)

		Trajectory				
		FLYBY 1B 1	SLOW 5A 2	ER S-PASS 3	ER ZIG-ZAG 4	FLYBY 1D 5
TEAM	1	.408	.247	.688	.465	.588
	4	.501	.284	.842	.632	.622

CELL STANDARD DEVIATIONS RMS ELEVATION SCORES (mrad)

		Trajectory				
		FLYBY 1B 1	SLOW 5A 2	ER S-PASS 3	ER ZIG-ZAG 4	FLYBY 1D 5
TEAM	1	.052	.031	.106	.068	.048
	4	.047	.044	.125	.102	.093

CELL MEANS OF RMS COMBINED SCORES (mrad)

		Trajectory				
		FLYBY 1B 1	SLOW 5A 2	ER S-PASS 3	ER ZIG-ZAG 4	FLYBY 1D 5
TEAM	1	.641	.369	1.061	.806	1.045
	4	.621	.356	1.116	.808	.936

CELL STANDARD DEVIATIONS RMS COMBINED SCORES (mrad)

		Trajectory				
		FLYBY 1B 1	SLOW 5A 2	ER S-PASS 3	ER ZIG-ZAG 4	FLYBY 1D 5
TEAM	1	.046	.037	.107	.064	.113
	4	.049	.048	.104	.086	.076

Appendix F
RESULTS OF TUKEY HSD TESTS

RESULTS OF TUKEY HSD TEST: RMS AZIMUTH SCORES

TRAJECTORIES BEING COMPARED					DIFFERENCE BETWEEN MEANS	TUKEY STATISTIC	SIGNIFICANCE
FLYBY 1B	SLOW 5A	ER S-PASS	ER ZIG-ZAG	FLYBY 1D			
1	2	3	4	5			
					.176	7.54	NS
					-.323	-13.84	--
					-.124	-5.31	NS
					-.384	-16.46	--
					-.499	-21.38	--
					-.300	-12.86	--
					-.560	-23.99	--
					.199	8.53	NS
					-.061	-2.61	NS
					-.260	-11.14	--

Note:

- (1) NS: Not Significant
- (2) Critical Value: 9.01, 5, 4 = 9.96
- (3) Results also shown on Figure 12.

RESULTS OF TUKEY HSD TEST: RMS ELEVATION SCORES

TRAJECTORIES BEING COMPARED					DIFFERENCE BETWEEN MEANS	TUKEY STATISTIC	SIGNIFICANCE
FLYBY 1B	SLOW 5A	ER S-PASS	ER ZIG-ZAG	FLYBY 1D			
1	2	3	4	5			
					.189	11.62	--
					-.311	-19.12	--
					-.094	-5.78	NS
					-.101	-6.21	NS
					-.500	-30.74	--
					-.283	-17.40	--
					-.290	-17.83	--
					.217	13.34	--
					.210	12.91	--
					.007	0.43	NS

Note:

(1) NS. Not Significant.

(2) Critical Value: 9.01, 5, 4 = 9.96

(3) Results also shown on Figure 13.

RESULTS OF TUKEY HSD TEST: RMS COMBINED SCORES

TRAJECTORIES BEING COMPARED					DIFFERENCE BETWEEN MEANS	TUKEY STATISTIC	SIGNIFICANCE
FLYBY 1B	SLOW 5A	ER S-PASS	ER ZIG-ZAG	FLYBY 1D			
1	2	3	4	5			
					.268	13.54	--
					-.458	-23.13	--
					-.176	-8.89	NS
					-.360	-18.18	--
					-.726	-36.66	--
					-.444	-22.42	--
					-.628	-31.72	--
					.282	14.24	--
					.098	4.95	NS
					-.184	9.29	NS

Note.

(1) NS: Not Significant

(2) Critical Value: 9.01, 5, 4 = 9.96

(3) Results also shown on Figure 14.

Appendix G
 RMS TRACKING ERROR VS. REPLICATION

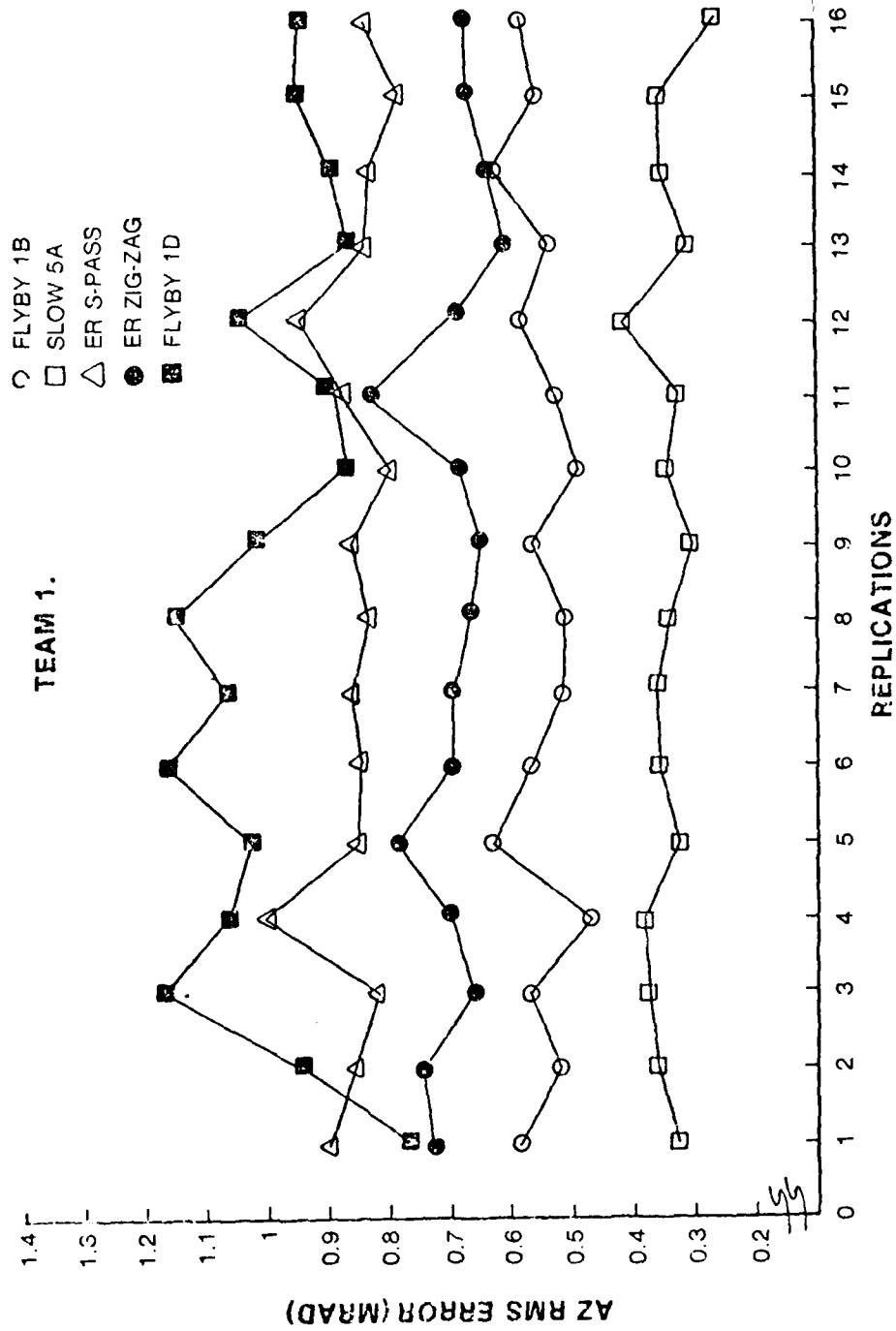

TEAM 1.

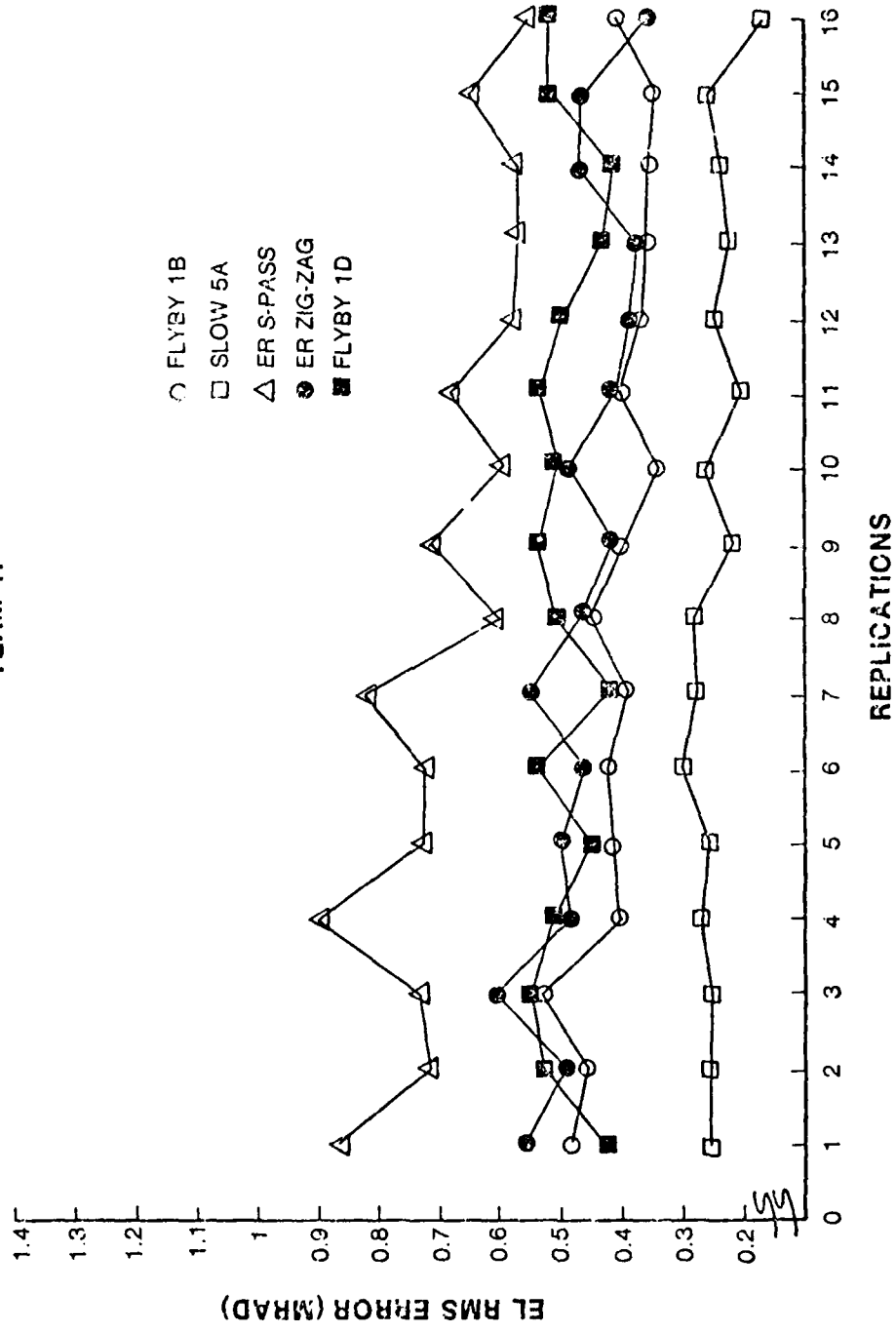

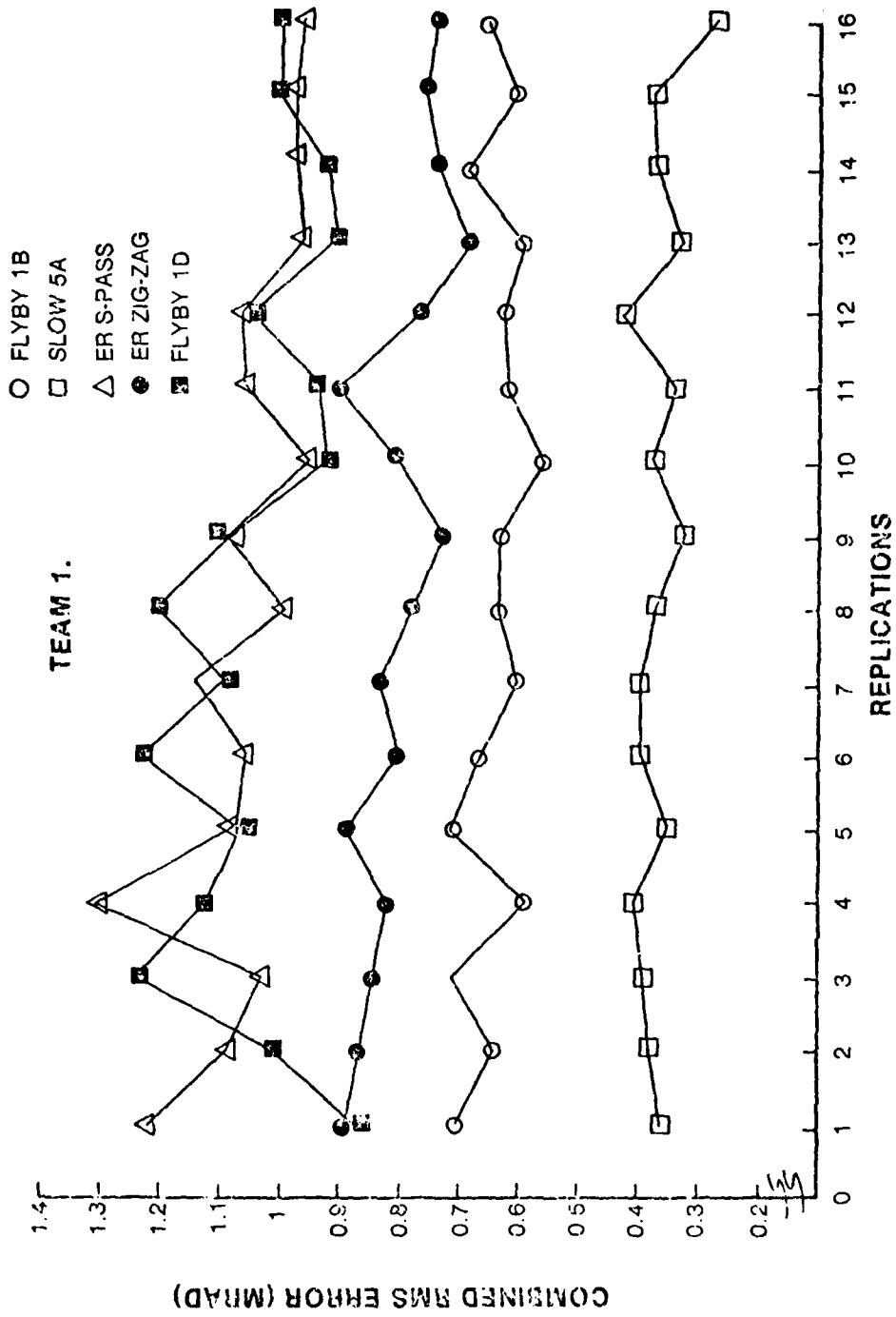

TEAM 4.

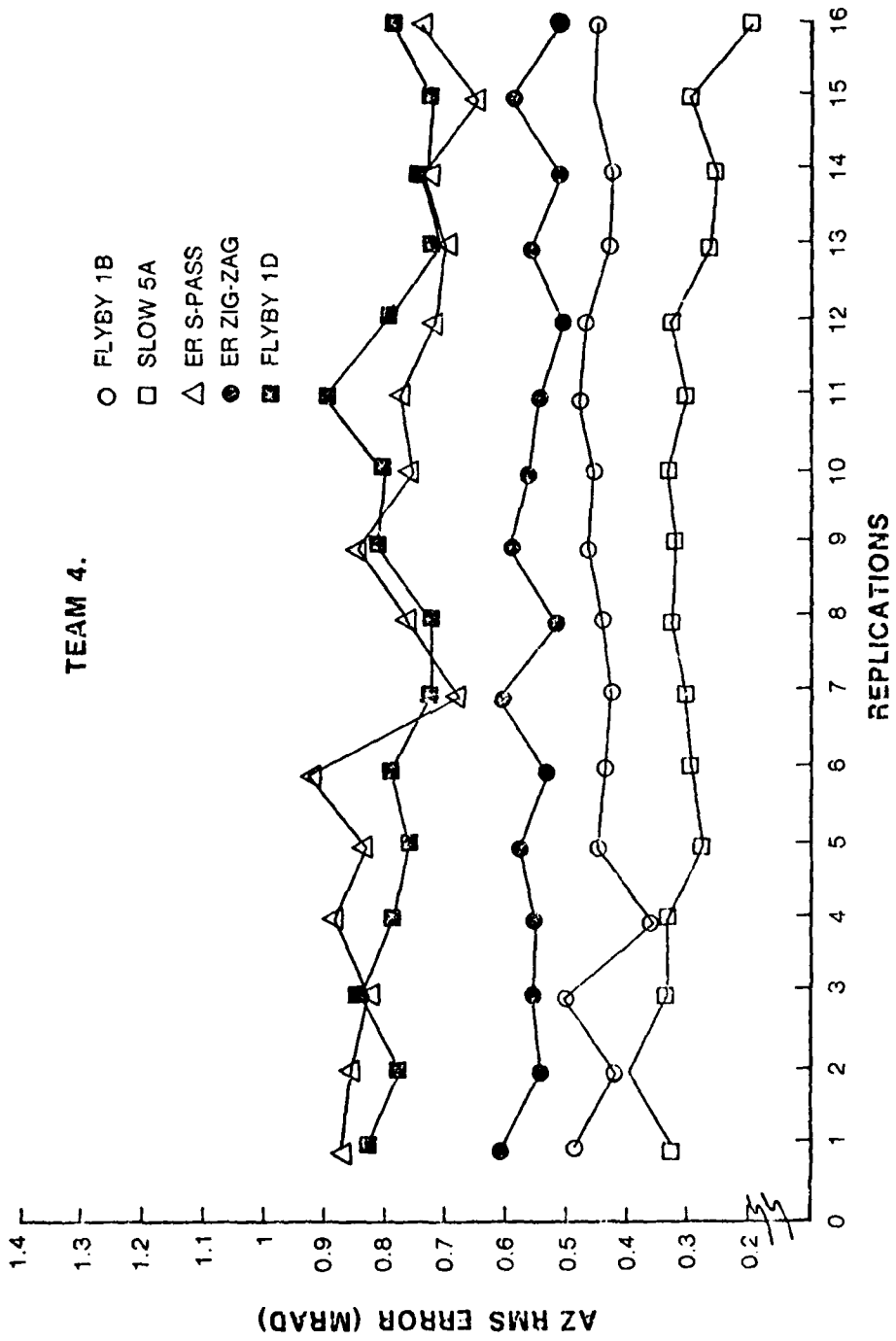

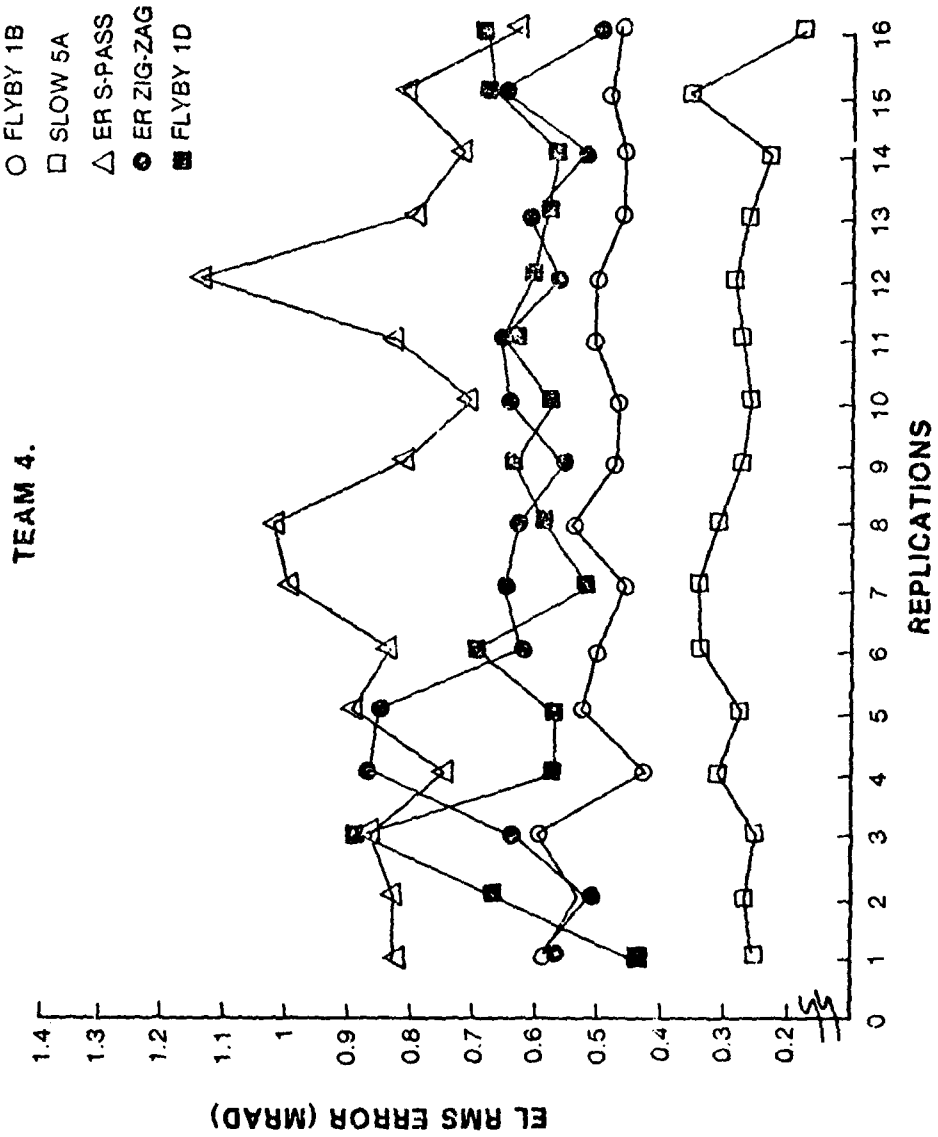

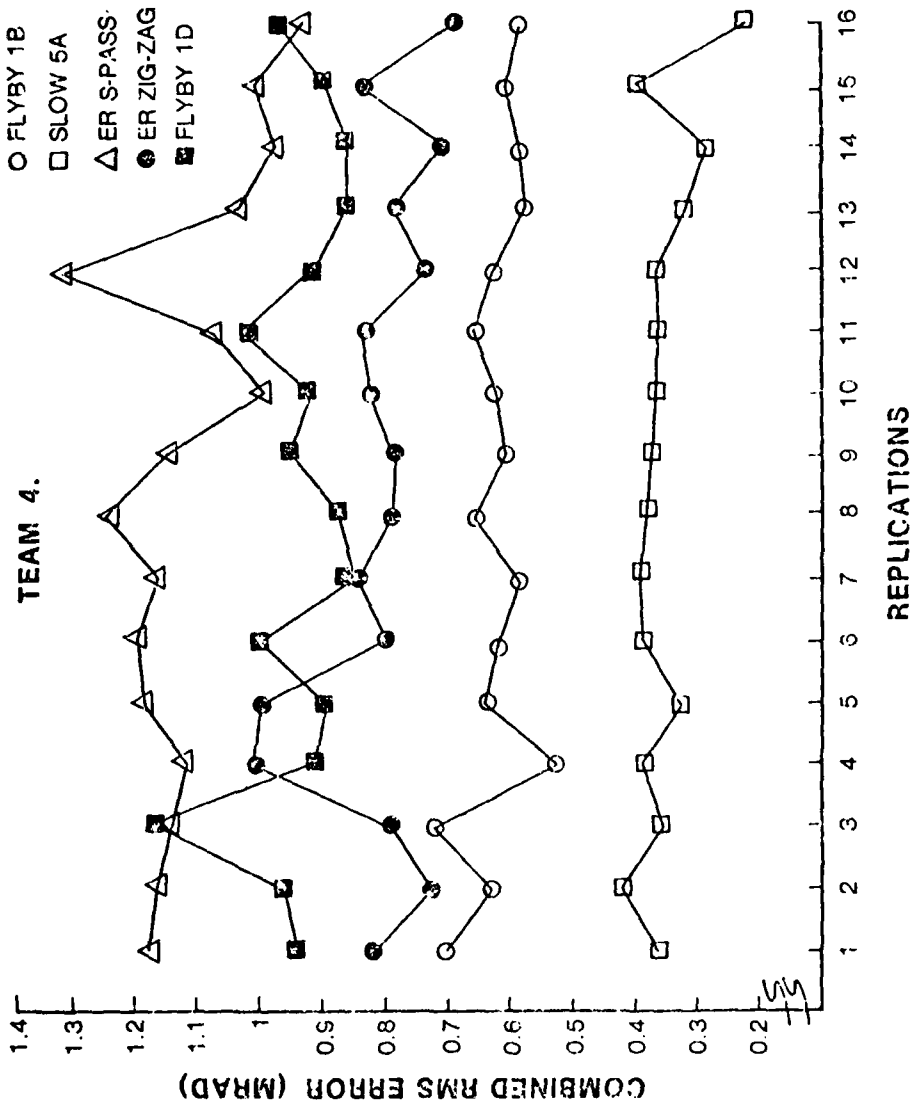

REFERENCES

Crabtree, M. S. and D. R. Nelson, September, 1979, The Effect of Background Imagery on Human Operator Target Tracking Performance, Systems Research Laboratories, Inc., Dayton, Ohio, SRL-TSG-TR-79-01.

Guenther, W. C., 1964, Analysis of Variance, Prentice-Hall, Englewood Cliffs, New Jersey.

Keppel, G., 1973, Design and Analysis, A Researcher's Handbook, Prentice-Hall, Englewood Cliffs, New Jersey.

Morrison, D. F., 1967, Multivariate Statistical Methods, McGraw-Hill, New York, New York.