

AD-A094 050

AIR FORCE OCCUPATIONAL MEASUREMENT CENTER RANDOLPH AFB TX F/6 5/9
AIR TRAFFIC CONTROL AND COMBAT CONTROL TEAM OPERATIONS, AFS 272--ETC(U)
DEC 80

UNCLASSIFIED

NL

1 of 2
AD
2001050



12-1-80

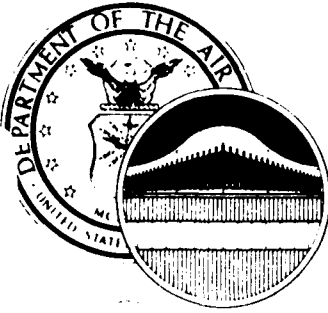

LEVEL II

2

UNITED STATES AIR FORCE

AD A094050

OCCUPATIONAL SURVEY REPORT

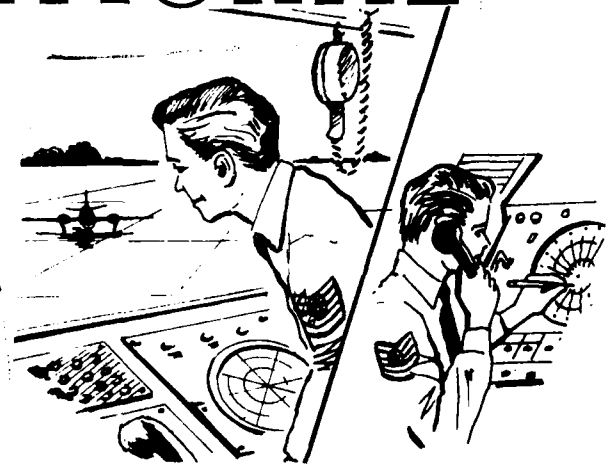

AIR TRAFFIC CONTROL AND COMBAT
CONTROL TEAM OPERATIONS

AFS 272X0/D.

AFPT 90-272-398

DECEMBER 1980

DTIC
ELECTE
JAN 23 1981

S

D

E

OCCUPATIONAL ANALYSIS PROGRAM
USAF OCCUPATIONAL MEASUREMENT CENTER
AIR TRAINING COMMAND
RANDOLPH AFB, TEXAS 78148

APPROVED FOR PUBLIC RELEASE; DISTRIBUTION UNLIMITED

FILE COPY

401889 81 1 22 029

TABLE OF CONTENTS

	<u>PAGE NUMBER</u>
PREFACE -----	111
SUMMARY OF RESULTS -----	iv
INTRODUCTION -----	1
CAREER LADDER STRUCTURE -----	6
ANALYSIS OF DAFSC GROUPS -----	16
ANALYSIS OF FIRST ENLISTMENT GROUPS -----	31
ANALYSIS OF CAREER LADDER DOCUMENTS -----	34
ANALYSIS OF TASK DIFFICULTY -----	36
JOB DIFFICULTY INDEX -----	40
ANALYSIS OF TRAINING EMPHASIS -----	42
CONUS - OVERSEAS COMPARISONS -----	48
COMPARISON OF THE CURRENT SURVEY WITH THE PREVIOUS SURVEY --	54
ANALYSIS OF WRITE-IN COMMENTS -----	57
IMPLICATIONS -----	60
APPENDIX A -----	61
APPENDIX B -----	62

Accession For	
NTIS GRA&I	<input checked="" type="checkbox"/>
DTIC TAB	<input type="checkbox"/>
Unannounced	<input type="checkbox"/>
Justification	
By	
Distribution/	
Availability Codes	
Dist	Avail and/or Special
A	

PREFACE

This report presents the results of a detailed Air Force Occupational Survey of the Air Traffic Control (AFS 272X0) career ladder and the Combat Control Team (AFS 272X0D) shred. The project was undertaken at the request of HQ ATC and the Air Force Manpower and Personnel Center (AFMPC) and was directed by the USAF Program Technical Training, Volume II. Authority for conducting occupational surveys is contained in AFR 35-2. Computer outputs from which the report was produced are available for use by operating and training officials.

Mr. David Williams, Inventory Development Specialist, developed the survey instrument. Captain Michael Hill analyzed the data and wrote the final report. This report has been reviewed and approved by Lieutenant Colonel Jimmy L. Mitchell, Chief, Airman Career Ladders Analysis Section, Occupational Analysis Branch, USAF Occupational Measurement Center, Randolph AFB, Texas 78148.

Computer programs for analyzing the occupational data were designed by Dr. Raymond E. Christal, Manpower and Personnel Division, Air Force Human Resources Laboratory (AFHRL), and were written by the Computer Programming Branch, Technical Services Division, AFHRL.

Copies of this report are available to air staff sections, major commands, and other interested training and management personnel upon request to the USAF Occupational Measurement Center, attention to the Chief, Occupational Analysis Branch (OMY), Randolph AFB, Texas, 78148.

This report has been reviewed and is approved.

BILLY C. McMASTER, Colonel, USAF
Commander
USAF Occupational Measurement
Center

WALTER E. DRISKILL, Ph.D.
Chief, Occupational Analysis Branch
USAF Occupational Measurement
Center

SUMMARY OF RESULTS

1. Survey Coverage: Inventory booklets were administered to Air Traffic Control and Combat Control Team Operations personnel from February through June 1980. Responses were received from 1,891 Air Traffic Control incumbents (36 percent) and 77 Combat Control Team incumbents (37 percent). The overall samples were representative in terms of MAJCOM and grade distributions and presented comprehensive pictures of both populations.
2. Specialty Structure: The overall job structure of these two ladders was found to be diverse, with 10 major job groups being identified. Jobs identified varied primarily on the basis of specialization in the areas of Control Tower, Radar, Supervisory, Perimeter Acquisition Radar, Combat Control Team, Mobile, Terminal Instrument Procedures, Analysis, or Instructor functions. In addition, several job types and/or subjob types were identified within the Radar, Control Tower, and Combat Control Team functional areas.
3. DAFSC and First Enlistment Differences: The majority of 3-, 5-, and 7-skill level 272X0 personnel specialize in technical functions related to Control Tower or Radar Air Traffic Control operations. Likewise, the 3-, 5-, and 7-skill level Combat Control Team personnel show little overlap in terms of tasks performed in common with either of the Control Tower or Radar Air Traffic Control functional areas. It is not until the 9-skill level that personnel devote the majority of their time to supervisory functions. The analysis of first enlistment groups revealed similar trends with regard to Control Tower, Radar Air Traffic Control, and Combat Control Team personnel cluster groups.
4. Career Ladder Documents: Both the AFR 39-1 Specialty Descriptions and STSs were found to provide good descriptions of the job functions performed by 272X0D personnel. Only minor modifications were suggested. Current training documents were generally supported by the data; however, some modifications were presented for consideration.
5. Analysis of Secondary Factors: The analysis of task difficulty data revealed the most difficult 272X0 tasks were generally supervisory in nature or tasks which involved very specialized expertise. The Job Difficulty Index (JDI) yielded similar results. Those jobs which reflected the highest JDI entailed Supervision, Combat Control Team, Terminal Instrument Procedures, or Radar related functions. The analysis of training emphasis data revealed common Radar, Tower, and general Air Traffic Control tasks were rated highest in training emphasis by AFS 272X0 personnel. Combat Control Team personnel rated tasks related to preparing for deployment and securing assault zones highest in training emphasis.
6. Write-in Comments: Respondents were given the opportunity to list any additional tasks not adequately covered and to make comments about the inventory or their career ladder at the end of each USAF Job Inventory. Air Traffic Control personnel directed their write-in comments toward three major areas of concern: pay and advancement, ATC regulations or local procedures, and misutilization of talents. Combat Control Team personnel were more concerned with the lack of adequate continuation and proficiency training.

7. Implications: The Air Traffic Control career ladder was divided into two main functional areas, Control Tower and Radar Air Traffic Control. Combat Control Team personnel perform few tasks in common with either of the major 272X0 Control Tower or Radar Air Traffic Control functional areas. In view of the specialization which was found to exist, it would appear that: (1) some form of channelized training for 272X0 personnel would be more cost effective and 2) the creation of a separate AFSC for 272X0D personnel should be given serious consideration.

OCCUPATIONAL SURVEY REPORT
AIR TRAFFIC CONTROL AND COMBAT CONTROL TEAM OPERATIONS
(AFSC 272X0/D)

INTRODUCTION

This is a report of an occupational survey of the Air Traffic Control career ladder (AFS 272X0) and the Combat Control Team Operations (AFS 272X0D) shred completed in October 1980. A previous survey of the 272X0/D career ladder was published in October 1976.

Background

As outlined in the AFR 39-1 Specialty Descriptions, Air Traffic Control Operators (AFSC 272X0) and Combat Control Team Operations personnel (AFSC 272X0D) "control enroute and terminal traffic by use of visual, radar, and/or conventional means."

Historically, the Air Traffic Control career ladder has undergone many changes since it was created in 1951. Initially three AFSCs were created:

272X0 Air Traffic Control Operator
272X1 Control Tower Operator
272X2 Aircraft Landing Control Operator

In August 1959, the 272X1 and 272X2 career ladders were converted to A and B shreds of the 272X0 career ladder. These shreds were deleted in March 1964. In July 1968, the A and B shreds were reinstated and a C shred was added. However, all three shreds were again deleted in March of 1970. The A, B, and C shreds were brought back in October 1974, but were deleted again in October 1977.

The history of the 272X0D shredout has been more stable. Created in July 1971, the D shred has remained relatively the same in terms of numerical designation and tasks performed.

Formal training for both 272X0 and 272X0D entry-level personnel consists of a 16-week, category A, Air Traffic Control Operator Course at Keesler AFB, MS. Upon completion of the course, all 272X0 personnel are assigned to units worldwide where they complete their certification through on-the-job training. Entry-level 272X0D personnel are required to complete additional training prior to their initial assignment. They must first complete the three-week Army Basic Airborne School at Fort Benning, GA. Then they attend the six-week MAC Combat Control Team Ready Qualification Training Course at Little Rock AFB. Finally, they attend the two-week Basic Survival Training Course at Fairchild AFB. They are then assigned to their respective units where they complete their certification through OJT.

APPROVED FOR PUBLIC RELEASE; DISTRIBUTION UNLIMITED

Objectives

The current study of the 272X0 career ladder was requested by HQ ATC/TTQ and the Air Force Manpower and Personnel Center (AFMPC). The purpose of the study was to examine the effect of the deletion of the A, B, and C shreds on personnel utilization and overall management of career ladder resources. The D shredout was included in the survey to determine the degree of task overlap which existed between it and the main ladder.

SURVEY METHODOLOGY

Inventory Development

The data collection instrument for this occupational survey was USAF Job Inventory AFPT 90-272-398. As a starting point, the tasks listed in the 1975 inventory were reviewed for currency. Next, pertinent career ladder documents, publications, and directives were reviewed for possible additional tasks. Then, field visits were made to Keesler, Little Rock, Homestead, Eglin, Hurlburt, Tinker, Dyess, and Kelly AFBs. During the field visits, a new tentative task list was developed. This tentative task listing was continually revised based on inputs from the field. When the task list was finally considered valid and complete, it consisted of 518 tasks grouped under 11 duty headings.

Survey Methodology

During the period February through June 1980, consolidated base personnel offices in operational units worldwide administered the inventory to job incumbents holding a DAFSC of 272X0, 272X0D, 27299, or a CEM Code of 27200. These job incumbents were selected from AFMPC personnel data tapes available through the Air Force Human Resources Laboratory (AFHRL).

Each individual who completed a job inventory first completed an identification and biographical information section. They were then directed to check each task performed in their current job. After checking all tasks performed, the individual then rated each of these tasks on a nine-point scale showing relative time spent on that task as compared to all other tasks checked. The ratings ranged from one (very small amount of time spent) through five (about average time spent) to nine (very large amount of time spent).

To determine relative time spent for each task checked by a respondent, an incumbent's ratings were assumed to account for 100 percent of his or her time spent on the job and were summed. Each task was then divided by the total task ratings and multiplied by 100. This procedure provided a basis for comparing tasks in terms of both percent members performing and average percent time spent.

Task Factor Administration

In addition to completing a job inventory, selected senior personnel from each specialty (272X0 and 272X0D) were also asked to complete a second booklet for either task difficulty or training emphasis. These task difficulty and training emphasis rating booklets were processed separately from the job inventories. The ratings which they yield are used in a number of different analyses which are discussed in detail later in the report.

Task Difficulty. Each individual completing a task difficulty booklet was asked to rate all 518 tasks on a nine-point scale from extremely low to extremely high as to the relative difficulty of each task. Difficulty was defined as the length or time it required an average member to learn to do that task. Task difficulty data were independently solicited from experienced 7- or 9-skill level personnel stationed worldwide in each specialty. The interrater reliability (as assessed through components of variance of standard group means) for the 57 total 272X0/D raters who returned task difficulty booklets was .96, which overall reflected very high agreement. Taken separately, the interrater reliability was .96 for the 52 272X0 raters. However, as a group, the 272X0D raters showed little agreement among themselves in terms of task difficulty ratings. Therefore, no reliable 272X0D task difficulty data were obtained.

Job Difficulty. After computing the combined 272X0/D task difficulty index for each task item, it was then possible to compute a job difficulty index (JDI) for the job groups identified in the survey analysis. This index provided a relative measure of which jobs, when compared to other jobs identified, were more or less difficult. An equation using the number of tasks performed and the average difficulty per unit time spent as variables was the basis for the JDI indices. The index ranges from one for very easy jobs to 25 for very difficult jobs. The indices were adjusted so that the average job difficulty index was 13.00. Thus, the more time spent on difficult tasks and the more tasks performed, the higher the job difficulty index.

Training Emphasis. Senior NCOs completing training emphasis booklets were asked to rate all of the tasks on a ten-point scale from no training required to extremely heavy training. Training emphasis is a rating of tasks indicating where emphasis should be placed on structured training for first-term personnel. Structured training is defined as training provided by resident technical schools, Field Training Detachments (FTD), Mobile Training Teams (MTT), formal OJT, or any other organized training method. Training emphasis data were independently solicited from experienced 7- or 9-skill level personnel stationed worldwide in each specialty. The interrater reliability for these raters was high (.98 for the combined sample of 272X0/D personnel), indicating there was good agreement among raters as to which tasks required some form of structured training and which did not. Tasks rated by the 45 raters in the Air Traffic Control ladder (272X0) had an average training emphasis rating of 2.6 and standard deviation of 2.3. Tasks rated by 13 Combat Control Team operation raters (272X0D) had an average training emphasis rating of 2.1 and a standard deviation of 2.0.

When used in conjunction with other factors, such as percent members performing, the task difficulty and training emphasis ratings can provide insights into training requirements. This information may help validate the lengthening or shortening of specific units of instruction in various training programs.

Survey Sample

Personnel were selected to participate in this occupational survey to insure a balanced representation across all MAJCOM and paygrade groups. In this study, in view of the large number of incumbents assigned to the Air Traffic Control career ladder (approximately 5,300), it was necessary to sample a smaller number. Thus, a stratified random sample of approximately 50 percent of 272X0 incumbents were selected to complete job inventory booklets. In addition, 27299 and CEM Code 27200 personnel were sampled to gain insight into the high level supervision of the career ladders.

Table 1 displays the distribution of the survey sample by major command. This table indicates that the 272X0 and the 272X0D samples were generally representative, with only minor deviations between the percentages assigned and the percentages comprising the survey sample.

Table 2 displays the distribution of the survey sample by paygrade groups. Generally, the various grades in the 272X0 distribution appear to be well sampled. The same is true of the 272X0D distribution, with the exception of a modest overrepresentation of sergeants (E-4) and a slight underrepresentation of master sergeants (E-7). Overall, the 272X0 and 272X0D samples are sufficiently representative in terms of grade distribution to provide an accurate picture of the jobs in the specialty.

TABLE 1
MAJCOM DISTRIBUTION OF SURVEY SAMPLE

COMMAND	272X0		272X0D	
	PERCENT OF ASSIGNED	PERCENT OF SAMPLE	PERCENT OF ASSIGNED	PERCENT OF SAMPLE
AFCC	90	86	*	0
ATC	3	5	*	2
MAC	*	1	86	88
TAC	*	2	5	9
USAFE	*	0	3	0
OTHER	6	6	6	1

* LESS THAN ONE PERCENT

TABLE 2
GRADE DISTRIBUTION OF SURVEY SAMPLE*

GRADE	272X0		272X0D	
	PERCENT OF ASSIGNED	PERCENT OF SAMPLE	PERCENT OF ASSIGNED	PERCENT OF SAMPLE
AIRMAN	18	17	14	10
SERGEANT (E-4)	28	25	21	25
STAFF SERGEANT (E-5)	28	30	36	38
TECHNICAL SERGEANT (E-6)	12	15	19	25
MASTER SERGEANT (E-7)	12	11	10	2
NOT REPORTED	-	2	-	-

* PAY GRADES E-8 AND E-9 NOT DISPLAYED DUE TO INCOMPLETE DATA

TOTAL 272X0 ASSIGNED	-	5,286	TOTAL 272X0D ASSIGNED	-	207
TOTAL 272X0 SAMPLED	-	1,891	TOTAL 272X0D SAMPLED	-	77
PERCENT SAMPLED	-	36%	PERCENT SAMPLED	-	37%

CAREER LADDER STRUCTURE

The structure of the jobs within the Air Traffic Control career ladder, including the Combat Control Team shredout, was examined on the basis of similarity of tasks performed and the relative percent of time ratings provided by job incumbents.

For the purpose of organizing individual jobs into similar units of work, an automated job clustering program was used. This hierarchical grouping program is a basic part of the Comprehensive Occupational Data Analysis Program (CODAP) system for job analysis. Each individual job description in the sample is compared to every other job description in terms of tasks performed and the relative amount of time spent on each task in the job inventory. The automated system is designed to locate the two job descriptions with the most similar tasks and percent time ratings and combine them to form a composite job description. In successive stages, new members are added to initial groups or new groups are formed based on the similarity of tasks and percent of time ratings in each individual job description. This procedure is continued until all individuals and groups are combined to form a single composite representing the total sample. The resulting analysis of the variety of groups of jobs serves to identify: (1) the number and characteristics of the different jobs which exist within the career ladder; (2) the tasks which tend to be performed together by the same respondents; and (3) the breadth or narrowness of the jobs which exist within the 272X0/D ladder.

The basic identifying group used in the hierarchical job structuring process is the Job Type. A job type is a group of individuals who perform many of the same tasks and spend similar amounts of time performing them. When there is a substantial degree of similarity between different job types, they are grouped together and labeled as a Cluster. In many career fields, there are specialized job types that are too dissimilar to be grouped into any cluster. These unique groups are labeled Independent Job Types (IJTs).

For the 272X0/D career ladder survey, 2,116 individual job descriptions were analyzed. As expected, the career ladder structure analysis identified four major areas of specialization (Clusters) which broke out on the basis of Control Tower, Radar Control, Combat Control Team, and Supervisory functions. In addition, six unique types of jobs (independent job types) were also identified. As illustrated in Figure 1, these various clusters and independent job types grouped in the following manner according to similarity of tasks performed and the percent of relative time spent on tasks:

- I. CONTROL TOWER PERSONNEL CLUSTER (GRP160)
 - a. Tower Trainer - Supervisors (GRP472)
 - b. Tower Controllers (GRP445)
 - c. Junior Tower Controllers (GRP218)
 - d. Tower Watch Supervisors (GRP186)

FIGURE 1

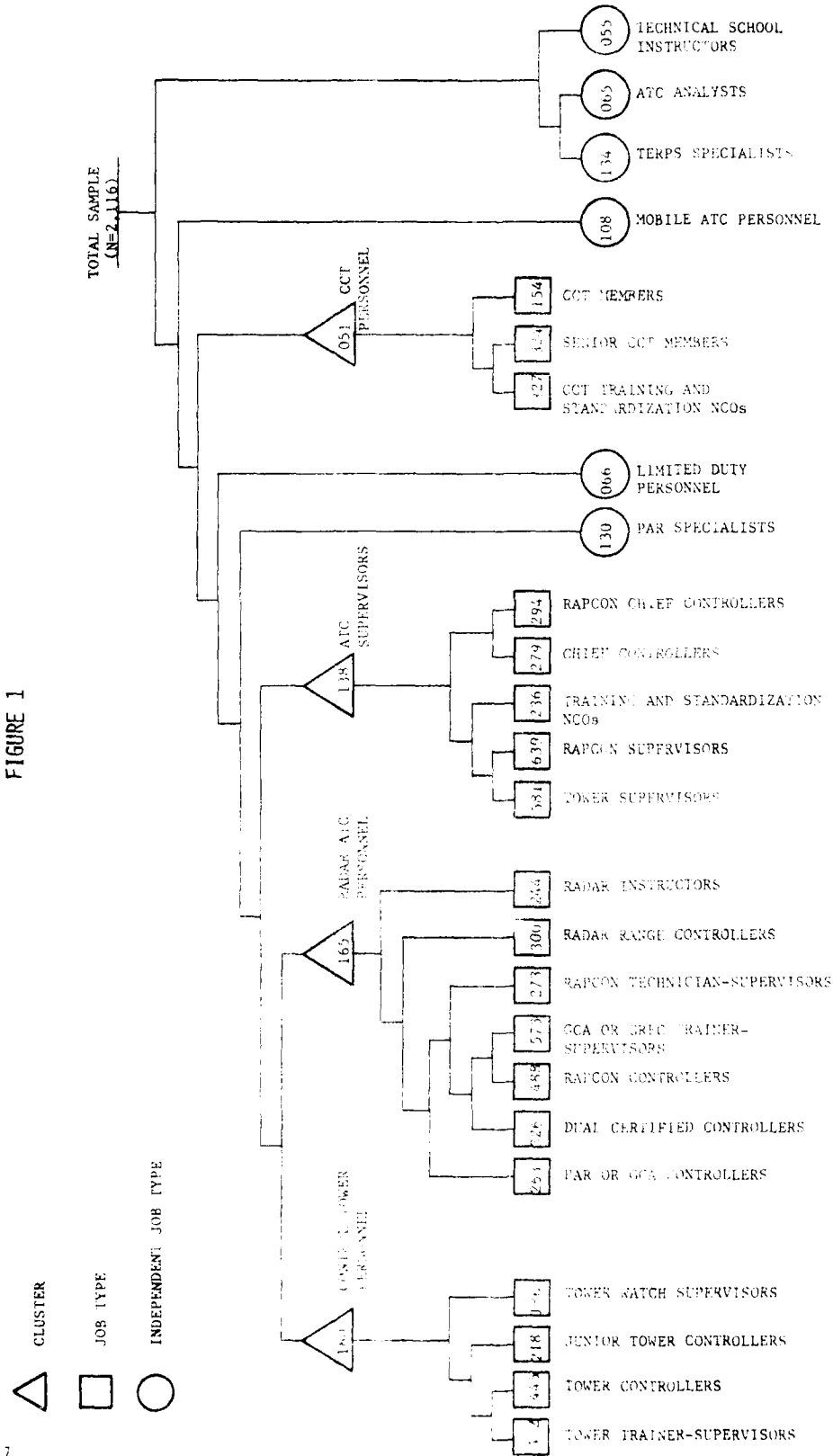

- II. RADAR AIR TRAFFIC CONTROL PERSONNEL CLUSTER (GRP165)
 - a. PAR or GCA Controllers (GRP263)
 - b. Dual Certified Controllers (GRP326)
 - c. Radar Approach Control (RAPCON) Controllers (GRP488)
 - d. GCA or GRFC Trainer-Supervisors (GRP573)
 - e. RAPCON Technician-Supervisors (GRP273)
 - f. Radar Range Controllers (GRP300)
 - g. Radar Instructors (GRP244)
- III. AIR TRAFFIC CONTROL SUPERVISORS CLUSTER (GRP138)
 - a. Tower Supervisors (GRP381)
 - b. RAPCON Supervisors (GRP639)
 - c. Training and Standardization NCOs (GRP236)
 - d. Chief Controllers (GRP279)
 - e. RAPCON Chief Controllers (GRP294)
- IV. PRECISION APPROACH RADAR (PAR) SPECIALISTS IJT (GRP130)
- V. LIMITED DUTY PERSONNEL IJT (GRP066)
- VI. COMBAT CONTROL TEAM (CCT) PERSONNEL CLUSTER (GRP051)
 - a. CCT Training and Standardization NCOs (GRP327)
 - b. Senior CCT Members (GRP324)
 - c. CCT Members (GRP154)
- VII. MOBILE AIR TRAFFIC CONTROL PERSONNEL IJT (GRP108)
- VIII. TERMINAL INSTRUMENT PROCEDURES (TERPS) SPECIALISTS IJT (GRP134)
- IX. ATC ANALYSTS IJT (GRP065)
- X. TECHNICAL SCHOOL INSTRUCTORS IJT (GRP055)

Overview

As previously mentioned, the clustering process identified four clusters and six independent job types. While members in each of the large 272X0 clusters -- Control Tower Personnel, Radar Air Traffic Control Personnel, and Air Traffic Control Supervisors -- perform a distinctly different job, they still perform many general Air Traffic Control tasks in common. These common tasks include:

- Issue altimeter settings
- Issue wheels down advisories
- Issue wind advisories
- Clean work areas or equipment
- Perform interfacility coordinations
- Perform intrafacility coordinations
- Issue weather advisories
- Make time checks

- Assign frequencies to aircraft
- Issue wake turbulence advisories
- Relay aircraft arrival or departure times
- Relay IFR clearances
- Issue airfield advisories
- File flight progress strips
- Separate aircraft using wake turbulence procedures
- Issue bird flight advisories
- Notify agencies of runways in use
- Request aircraft position information
- Remove or replace teleautewriter paper
- Activate backup communication systems

Thus, the 272X0 job structure is somewhat homogeneous due to this overlap in tasks across job groups.

This is not the case with the Combat Control Team cluster and the six independent job types. These jobs entail either a unique set of tasks or a very limited number of tasks. Consequently, they perform only a limited number of tasks in common with other job groups. Thus, these groups present a much more heterogeneous picture than was found in the three main 272X0 clusters.

Job Group Descriptions

A brief discussion of each of the four clusters and six independent job types is presented below. Additional background information concerning each cluster and independent job type is provided in the two tables at the end of this section. The job types and subjob types which combine to form each cluster are discussed in detail in Appendix A.

I. CONTROL TOWER PERSONNEL CLUSTER (GRP160). The 662 members of this cluster work in a tower environment and control all landings and takeoffs at their respective installations. Routine tasks include:

- Maintain surveillance of airport movement and traffic areas
- Issue taxiing instructions
- Sequence landing aircraft
- Approve or disapprove takeoffs
- Approve or disapprove aircraft taxiing
- Control vehicles, equipment, or personnel in movement area using radios
- Request aircraft releases from departure control
- Operate airfield approach lighting systems
- Sequence departing aircraft
- Operate primary crash alarm systems

The cluster is diverse in nature, being composed of personnel with little or no experience (Junior Tower Controllers), experienced personnel (Tower Controllers) and worker-supervisors (Tower-Trainer Supervisors and Tower Watch Supervisors). These four job types are discussed in more detail in Appendix A.

II. RADAR AIR TRAFFIC CONTROL PERSONNEL CLUSTER (GRP165). Unlike the Control Tower Personnel, Radar Air Traffic Control Personnel devote little or no time to Control Tower functions. Instead, they specialize in performing the various Radar functions involved in air traffic control. Common tasks include:

- Identify aircraft using transponder methods
- Perform radar handoffs
- Coordinate aircraft handoffs
- Issue missed approach instructions
- Assign transponder modes and codes
- Request aircraft altitude verifications
- Control and separate arriving aircraft using precision approach radar (PAR)
- Report radar malfunctions
- Provide radar surveillance approaches

Personnel within this cluster tend to specialize in seven different kinds of jobs. Of these, three job types account for the majority of cluster personnel - PAR or GCA Controllers (14 percent), Dual Certified Controllers (15 percent), and RAPCON Controllers (57 percent). The other four job types consist of personnel who either perform other functions in addition to radar control tasks or perform very unique kinds of radar control jobs.

III. AIR TRAFFIC CONTROL SUPERVISORS CLUSTER (GRP138). These supervisory personnel tend to specialize in five different areas of supervision. The majority hold a 7- (41 percent) or 9-skill level (45 percent) or CEM Code 27200 (10 percent). Much of their job involves supervision. However, the members of this cluster perform a higher average number of tasks (194) than any of the other clusters identified. This is due to the fact that many perform nonsupervisory functions in addition to their supervisory functions. Examples of supervisory tasks which these personnel perform in common include:

- Conduct briefings on ATC procedures
- Evaluate ATC methods or techniques
- Evaluate ATC problem areas
- Counsel personnel on personal or military related problems
- Conduct facility tours
- Conduct ATC facility self inspections
- Prepare and submit recommendations for improving and standardizing Air Traffic Control procedures
- Counsel trainees on training progress
- Perform on-the-job performance evaluations of Air Traffic Controllers

IV. PRECISION APPROACH RADAR (PAR) SPECIALISTS IJT (GRP130). This independent job type of 30 individuals specialize in the performance of PAR related tasks. They perform few tasks on the average (38), which is primarily due to the fact that they devote little time to secondary radar functions. This may account for their lower job satisfaction. Interestingly, half indicate they hold the 7-skill level while the rest hold either a 5- (30 percent) or a 3-skill level (20 percent). Listed below are some representative tasks:

- Provide precision radar approaches
- Issue wheels down advisories
- Issue wind advisories
- Clean work areas or equipment
- Issue decision height altitude advisories
- Mark decision height lines on radar indicators
- Control and separate arriving aircraft using precision approach radar (PAR)
- Provide radar surveillance approaches
- Perform radar equipment turn around procedures
- Issue missed approach instructions

V. LIMITED DUTY PERSONNEL IJT (GRP066). Like the PAR Specialists IJT (GRP130), this group is composed of 3-, 5-, and 7-skill level personnel. However, most hold the 5- (55 percent) or the 3-skill level (27 percent). A little over a third (36 percent) indicate they are not certified. Of those certified, 27 percent indicate they are certified in RAPCON, 27 percent indicate they are certified in GCA Final Control, and another 27 percent indicate they are certified in the Control Tower. Obviously, they are a very diverse group who perform few tasks in common. Those tasks which draw them together are General Air Traffic Control functions which are performed in common by personnel in the three clusters previously identified (Control Tower Personnel, Radar Air Traffic Control Personnel, and Air Traffic Control Supervisors). Listed below are tasks which are most representative of this group:

- Issue altimeter settings
- Make time checks
- Issue wheels down advisories
- Issue weather advisories
- Clean work areas or equipment
- Issue wake turbulence advisories
- Assign frequencies to aircraft
- Notify agencies of runways in use
- Issue bird flight advisories

VI. COMBAT CONTROL TEAM CLUSTER (GRP051). Combat Control Team members perform jobs which are very distinct in comparison to the three other job clusters previously identified. They devote little relative time to the performance of general air traffic control, radar, and control tower functions. Although they are responsible for controlling aircraft within an assault zone, they devote the majority of their job time to preparing for deployment. Most indicate they are in their second (30 percent) or subsequent enlistment (52 percent). Typical tasks performed include:

- Perform Combat Control Team demolition operations
- Operate portable communication equipment
- Mark assault zones
- Perform combat control training missions
- Perform Combat Control Team unit tactics operations
- Install or replace portable communication equipment at assault zones
- Configure field gear for air-land employments
- Configure communication equipment for parachute employments
- Operate portable navaid equipment.

VII. MOBILE AIR TRAFFIC CONTROL PERSONNEL IJT (GRP108). The members of this independent job type perform a very specialized job. They devote relatively little time to the performance of Air Traffic Control related tasks. The majority (72 percent) of their relative time is devoted to performing mobility exercise related tasks. Consequently, they are very dissatisfied with their jobs. This group shows the lowest relative job satisfaction of any group identified. Typical tasks include:

- Operate M-series vehicles and associated equipment
- Erect or tear down ATC facilities
- Erect or tear down containment facilities
- Load or offload equipment from aircraft or vehicles
- Perform mobility training exercises
- Position mobile ATC equipment
- Clean work areas or equipment
- Operate mobile radio communications equipment
- Review operation orders or plans
- Supervise Air Traffic Control Operators (AFSC 27250)

VIII. TERMINAL INSTRUMENT PROCEDURES (TERPS) SPECIALISTS IJT (GRP134). This group of senior personnel are generally assigned either at a headquarters or a communications group location. Their area of expertise is clearly terminal instrument procedures. In addition, they devote considerable time to staff level and evaluation functions. They do not perform many technical air traffic control tasks. However, most of those assigned to communications groups appear to be heavily involved in training and standardization. Examples of typical tasks performed in common by TERPS specialists include:

- Review TERPS packages
- Implement changes to flight information publications (FLIP)
- Prepare and submit TERPS packages
- Write general correspondence
- Write staff studies, surveys, or special reports
- Evaluate compliance with performance standards
- Determine work priorities
- Evaluate facility letters of agreement
- Plan briefings
- Develop search radar minimum altitude vectoring charts

IX. AIR TRAFFIC CONTROL ANALYSTS (GRP065). The majority of these 7- (42 percent), 9- (37 percent), and CEM Code 27200 (21 percent) personnel are assigned at the headquarters level. As ATC Analysts, they do not supervise other individuals or perform technical Air Traffic Control functions. The majority of their time is devoted to evaluating conditions in the field. Examples of typical tasks include:

- Evaluate ATC recommendations
- Evaluate ATC problem areas
- Evaluate facility letters of agreement
- Write general correspondence
- Evaluate facility operation letters
- Evaluate ATC methods or techniques

Evaluate ATC operations reports
Prepare and submit recommendations for improving and
standardizing Air Traffic Control procedures
Evaluate inspection reports or procedures
Write staff studies, surveys, or special reports

X. TECHNICAL SCHOOL INSTRUCTORS (GRP055). The majority of these personnel are assigned at Keesler AFB. They devote most of their relative time to classroom and related functions. Unlike the Radar Instructors job type (GRP244), they do not devote much time to radar related tasks. Typical tasks performed include:

Counsel trainees on training progress
Evaluate progress of resident course students
Administer tests
Conduct resident course classroom training
Maintain training records, charts, or graphs
Conduct ATC training for foreign nationals
Evaluate training methods or techniques
Prepare lesson plans
Conduct facility tours
Counsel personnel on personal or military related problems

Summary

Overall, three major technical job functions were identified within the 272X0/D career ladder. These entail (1) Control Tower, (2) Radar, and (3) Combat Control Team functions. Each of these functional areas incorporate a distinct group of technical tasks which differentiate it from the others. However, there was considerable overlap between the Control Tower and Radar functions in terms of general Air Traffic Control tasks. This was not the case with the Combat Control Team function since there was very little overlap between Combat Control Team personnel and the other two functional groups in the general Air Traffic Control duty or any other duty area. This lack of overlap tended to support the current classification structure of a separate shredout for Combat Control Team members. It would also support the proposed creation of a new AFSC designation for 272X0D personnel.

In addition to the Combat Control Team job, six other unique or specialized functions were identified in the analysis process. They reflect very narrow areas of specialization or the lack of it (limited duty personnel). These jobs are unique in comparison to the major clusters in that they show little overlap in terms of duties and tasks.

TABLE 3

BACKGROUND INFORMATION BY CLUSTERS AND INDEPENDENT JOB TYPES

	RADAR		AIR		TRAFFIC		PAR		LTD DUTY		CCT		MOBILE		TERPS		ATC		TECH	
	CONT PERSONNEL CLUSTER (GRP160)	CONT PERSONNEL CLUSTER (GRP165)	TRAFFIC CONT PERSONNEL CLUSTER (GRP138)	AIR TRAFFIC CONT PERSONNEL CLUSTER (GRP130)	TRAFFIC CONT PERSONNEL CLUSTER (GRP130)	SPECS LJT (GRP066)	PAR SPECS LJT (GRP066)	LTD DUTY PERSONNEL LJT (GRP066)	CCT PERSONNEL CLUSTER (GRP051)	MOBILE PERSONNEL LJT (GRP108)	TERPS SPECIALISTS LJT (GRP134)	ATC ANALYST LJT (GRP065)	TECH SCHOOL INSTR LJT (GRP055)							
NUMBER IN GROUP	662	883	208	30	11	74	19	5	19	19	19	20								
AVERAGE NUMBER OF TASKS PERFORMED	93	115	194	38	32	89	21	25	25	25	25	26								
AVERAGE PAYGRADE GROUP	4.5	4.7	7.0	4.6	4.1	5.1	4.8	7.5	7.6	7.6	7.6	5.4								
DAFSC																				
27230/D*	10%	5%	0	20%	27%	3%	0	0	0	0	0	0								
27250/D*	55%	58%	3%	30%	55%	-9%	40%	0	0	0	0	50%								
27270/D*	35%	35%	54%	50%	18%	-4%	60%	37%	42%	37%	42%	45%								
27299	0	1%	29%	0	0	5%	0	53%	37%	53%	37%	0								
27200	0	0	12%	0	0	3%	0	0	0	10%	21%	5%								
OTHER	0	1%	2%	0	0	0	0	0	0	0	0	0								
AVERAGE MONTHS IN CAREER FIELD	64	70	186	83	47	84	78	209	207	207	207	92								
AVERAGE MONTHS TAFMS	89	93	216	98	67	117	95	245	245	245	245	111								
PERCENT IN FIRST ENLISTMENT	38%	28%	1%	27%	36%	14%	20%	0	0	0	0	5%								
PERCENT ASSIGNED OVERSEAS	21%	28%	30%	33%	18%	30%	0	53%	32%	53%	32%	0								
PERCENT WHO SUPERVISE OTHERS	34%	40%	75%	27%	9%	51%	40%	47%	5%	47%	5%	35%								

* 272X0D PERSONNEL APPEAR ONLY IN THE CCT PERSONNEL CLUSTER; ALL OTHER CLUSTERS AND LJTS ARE COMPRISED ENTIRELY OF 272X0 PERSONNEL

TABLE 4
 JOB INTEREST AND RELATED DATA BY CLUSTERS AND INDEPENDENT JOB TYPES
 (PERCENT MEMBERS RESPONDING)

	RADAR		AIR		TRAFFIC		PAR		LTD		CCT		MOBILE		TERPS		TECH		
	TOWER	OPRTS	PERSONNEL	CLUSTER	CONT	SUPS	CLUSTER	JJT	PERSONNEL	DUTY	PERSONNEL	CLUSTER	PERSONNEL	ATC	SPECIALIST	JJT	ANALYST	SCHOOL	INSTR
	(N=662)	(N=883)	(N=208)	(N=130)	(N=74)	(N=11)	(N=11)	(N=30)	(N=11)	(N=74)	(N=5)	(N=19)	(N=19)	(N=19)	(N=19)	(N=19)	(N=19)	(N=19)	(N=20)
I FIND MY JOB:																			
DULL	7	5	5	23	5	5	5	23	9	9	5	5	40	11	11	11	11	15	15
SO-SO	7	5	5	13	5	5	7	13	9	9	7	7	20	0	0	0	0	10	10
INTERESTING	83	86	88	57	88	88	82	57	82	82	87	87	20	84	84	84	84	75	75
NO RESPONSE	3	3	2	7	2	2	7	7	0	0	1	1	20	5	5	5	5	0	0
MY JOB UTILIZES MY TALENTS:																			
NOT AT ALL TO VERY LITTLE	15	12	5	37	5	5	37	37	9	9	11	11	80	11	11	16	16	10	10
FAIRLY WELL TO PERFECTLY	83	87	93	63	93	93	63	63	91	91	87	87	20	89	89	84	84	90	90
NO RESPONSE	2	1	2	0	2	2	0	0	0	0	2	2	0	0	0	0	0	0	0
MY JOB UTILIZES MY TRAINING:																			
NOT AT ALL TO VERY LITTLE	9	9	5	37	5	5	37	37	9	9	14	14	60	16	16	26	26	15	15
FAIRLY WELL TO PERFECTLY	89	90	94	63	94	94	63	63	91	91	85	85	40	84	84	74	74	85	85
NO RESPONSE	2	1	1	0	1	1	0	0	0	0	1	1	0	0	0	0	0	0	0
I PLAN TO REENLIST:																			
NO OR PROBABLY NO	49	51	45	37	45	45	37	37	64	64	35	35	0	42	42	47	47	40	40
YES OR PROBABLY YES	49	48	53	64	53	53	64	64	36	36	65	65	100	58	58	42	42	60	60
NO RESPONSE	2	1	2	3	2	2	3	3	0	0	0	0	0	0	0	11	11	0	0

ANALYSIS OF DAFSC GROUPS

In addition to examining the various types of jobs within the 272X0 and 272X0D AFSCs (as discussed in the CAREER LADDER STRUCTURE section), this report also includes an analysis of the tasks performed by incumbents at the various skill levels. As reflected in Table 5, the majority of 3-, 5-, and 7-skill level 272X0 personnel break out in the Control Tower and Radar Air Traffic Control clusters. The majority of the DAFSC 27290 and 27200 CEM code personnel are included within the ATC Supervisor cluster. Since the job structure analysis showed differences in tasks performed by personnel in each of these clusters, it is more appropriate to discuss skill level differences within the various clusters rather than discussing these differences by overall skill level. This analysis of DAFSC data by cluster groups shows a clearer picture of the differences which exist among skill level personnel in the field. This data can then be used to evaluate whether personnel are being utilized in the manner specified by the current specialty descriptions (AFR 39-1) and can also serve as a basis for considering changes to current utilization policies or training programs.

DAFSC 272X0 Personnel Within the Control Tower Personnel Cluster

Air Traffic Control personnel within the Control Tower personnel cluster accounted for approximately 31 percent of the total sample. Table 6 presents a summary of background information for Control Tower personnel by skill level. Table 7 presents information on relative percent time spent on duties for Control Tower and Radar clusters.

DAFSC 27230. Personnel with a duty AFSC of 27230 accounted for 10 percent of the Control Tower cluster respondents. As the information in Table 6 illustrates, the majority of the semiskilled (3-skill level) control tower respondents are uncertified. However, they perform many of the same kinds of functions as 27250 control tower personnel. The primary difference between the 3- and 5-skill levels is that the 3-skill level individual performs most functions under the direct supervision of training personnel.

Control Tower, 3-skill level personnel perform a large body of tasks in common, as indicated by the percentage of personnel performing individual tasks. Fifteen tasks were performed in common by over 90 percent of the 3-skill level airmen in the control tower cluster. These tasks are listed below:

- Issue altimeter settings
- Issue wheels down advisories
- Issue taxiing instructions
- Issue wind advisories
- Relay aircraft arrival or departure times
- Approve or disapprove aircraft taxiing
- Clean work areas or equipment
- Request aircraft releases from departure control
- Approve or disapprove takeoffs
- Sequence landing aircraft

- Operate rotating beacons
- Make time checks
- Operate airfield approach lighting systems
- Issue wake turbulence advisories
- Issue bird flight advisories

DAFSC 27250. Personnel with a duty AFSC of 27250 accounted for 55 percent of the respondents in the Control Tower Personnel cluster. As the information in Table 7 illustrates, there is no noticeable shift in job emphasis from the 3- to the 5-skill level in terms of Duty areas.

The jobs performed by 5-skill level Control Tower personnel are even more homogeneous than those performed by personnel at the 3-skill level. There were 25 tasks performed by over 90 percent of all 5-skill level Control Tower cluster personnel. These include all of the 15 tasks which were performed by 90 percent or more of the 3-skill level Control Tower personnel plus the following 10 tasks:

- Maintain surveillance of airport movement and traffic areas
- Control vehicles, equipment, or personnel in movement area using radios
- Issue weather advisories
- Operate primary crash alarm systems
- Sequence departing aircraft
- Notify agencies of runways in use
- Authorize intersection takeoffs
- Separate aircraft using wake turbulence procedures
- Activate emergency evaluation alarm systems
- Advise pilots of observed abnormal aircraft conditions

The tasks which most clearly distinguish 5-skill level control tower personnel from their 3-skill level counterparts involve supervision, training, or the more difficult procedural tasks. Examples of these include:

- Supervise apprentice Air Traffic Control Operators (AFSC 27230)
- Counsel trainees on training progress
- Initiate antihijacking procedures
- Conduct briefings on ATC procedures
- Initiate emergency assistance procedures
- Evaluate OJT trainees
- Perform OJT performance evaluations of Air Traffic Controllers
- Perform simulated crash, alert, or disaster control exercise

DAFSC 27270. Respondents with a duty AFSC of 27270 accounted for 35 percent of all personnel in the Control Tower cluster. As the information in Table 7 illustrates, the award of the technician skill level does not signal a significant shift in job emphasis from technical air traffic control to supervisory functions. Instead, most 7-skill level Control Tower personnel tend to spend very little time on supervisory functions, while continuing to perform many of the same kinds of technical tasks performed by the 5-skill level specialists.

As was the case with the 5-skill level personnel, Control Tower Technicians perform a large number of technical tasks in common. The 26 tasks performed in common by over 90 percent of all 7-skill level Control Tower cluster personnel are listed in Table 8. Observe that the majority of these tasks are also performed by 90 percent or more of the 5-skill level Control Tower personnel.

The tasks performed by 7-skill level Control Tower personnel which most clearly illustrate the differences between the 7-skill level and subordinate 3- and 5-skill level Control Tower personnel are listed below:

- Assign personnel to duty positions
- Supervise Air Traffic Control Operators (AFSC 27250)
- Prepare APRs
- Counsel personnel on personal or military related problems
- Conduct Control Tower proficiency training
- Perform on-the-job (OJT) performance evaluations of Air Traffic Controllers
- Assign OJT trainers
- Direct Visual Meteorological Conditions (VMC) Control Tower activities
- Interpret policies, directives, or procedures for subordinates

DAFSC 272X0 Personnel Within the Radar Air Traffic Control Personnel Cluster

Air Traffic Control respondents within the Radar Air Traffic Control personnel cluster accounted for approximately 42 percent of the survey population. The information in Table 9 presents a summary of selected background information for the Radar Air Traffic Control Personnel cluster by skill level. In addition, relative time spent on duties information for these skill levels are presented back in Table 7.

DAFSC 27230. Personnel with a duty AFSC of 27230 accounted for five percent of the Radar Air Traffic Control cluster respondents. Almost two thirds of these individuals were uncertified (see Table 9). The majority of their relative time was devoted to tasks within the general Air Traffic Control and Control Tower duty areas (see Table 7).

As with 3-skill level respondents within the Control Tower cluster, semiskilled Radar ATC cluster personnel performed many less difficult tasks in common with their more experienced 5-skill level counterparts. However, these tasks are generally performed under the direct supervision of an experienced Radar Air Traffic Controller in an OJT training environment.

Although very homogeneous, the jobs performed by 3-skill level Radar ATC cluster personnel are less homogeneous than those performed by their 3-skill level Control Tower cluster counterparts. This is evidenced by the fact that only nine tasks are performed in common by 90 percent or more of semiskilled Radar ATC personnel. These nine tasks, listed below, include both general Air Traffic Control and Radar functions:

- Clean work areas or equipment
- Issue altimeter settings
- Identify aircraft using transponder methods
- Issue wind advisories
- Perform radar handoffs
- Assign frequencies to aircraft
- Request aircraft altitude verifications
- Identify aircraft using primary radar methods
- Issue lost communication instructions

In comparing the job description for 3-skill level Radar ATC respondents to the job description for 5-skill level Radar respondents, a high degree of overlap was found to exist in terms of tasks performed. However, as would be expected, higher percentages of 5-skill level Radar ATC respondents indicated they performed training, supervisory, and other more technical kinds of tasks. Examples of these tasks include:

- Counsel trainees on training progress
- Provide radar assistance to emergency aircraft
- Supervise Apprentice Air Traffic Control Operators (AFSC 27230)
- Direct emergency aircraft to alternate airports
- Control precautionary approaches
- Evaluate OJT trainees
- Maintain training records, charts, or graphs
- Perform OJT performance evaluations of Air Traffic Controllers
- Operationally check radar display of touchdown and bracketing reflectors
- Initiate emergency assistance procedures
- Provide special handling for aircraft NAVAID flight inspections

DAFSC 27250. Personnel with a duty AFSC of 27250 accounted for 58 percent of the Radar Air Traffic Control cluster personnel. As the information in Table 7 illustrates, there was only a minimal shift in job emphasis when 5-skill level Radar ATC respondents were compared to 3-skill level respondents.

The majority of job time was expended performing tasks related to general Air Traffic Control and Radar functions. With the award of the 5-skill level, personnel devote slightly more of their relative job time to directing and implementing, training, and emergency related technical tasks. This accounts for the differences among the two job descriptions noted above. The tasks performed by 90 percent or more of the 5-skill level Radar ATC respondents (see Table 10) included the same nine tasks performed by 90 percent or more of the 3-skill level Radar ATC respondents. However, 5-skill Radar ATC respondents are more homogeneous in that 27 tasks are performed by 90 percent or more of these individuals.

DAFSC 27270. Personnel with the 7-skill level represented 35 percent of the Radar Air Traffic Control cluster respondents. With the award of the technician skill level, there was a gradual shift in job emphasis with incumbents becoming somewhat more involved in the performance of tasks related to directing and implementing, organizing and planning, training, and inspecting

and evaluating. However, 90 percent or more of these technicians perform the same 27 technical tasks which the 5-skill level Radar ATC group performed in common. Consequently, DAFSC 27270 Radar Air Traffic Control cluster personnel perform most of the same technical tasks as 5-skill level Radar ATC cluster personnel, but have the added responsibility of performing supervisory tasks. The supervisory tasks listed below best illustrate the differences between the 7- and 5-skill level Radar ATC cluster groups:

- Supervise Air Traffic Control Operators (AFSC 27250)
- Assign personnel to duty positions
- Prepare APRs
- Approve or disapprove power transfers
- Counsel personnel on personal or military related problems
- Supervise Air Traffic Control Technicians (AFSC 27270)
- Assign on-the-job training (OJT) trainers
- Perform on-the-job performance evaluations of Air Traffic Controllers
- Direct Precision Approach Radar activities
- Maintain facility status boards
- Interpret policies, directives, or procedures for subordinates
- supervise Apprentice Air Traffic Control Operators (AFSC 27230).

DAFSC 272X0D - Combat Control Team Operations

Analysis of skill level groups within this shred was somewhat more difficult due to the small number of 272X0D personnel returning job inventories. Only two individuals with DAFSC 27230D were included in the final sample; therefore, no analysis of this group was performed. However, both the 5- and the 7-skill level groups were of sufficient size to make valid comparisons (27250D - 33 members; 27270D - 28 members).

DAFSC 27250D. Personnel holding the 272X0D duty AFSC represented two percent of the total survey population. As the information in Table 11 illustrates, the relative job emphasis for 5-skill level D-shred personnel lies in the areas of performing general Air Traffic Control functions and performing Combat Control Operations and Training.

Table 12 lists 25 of the 50 tasks performed by 50 percent or more of 27250D personnel. The fact that so many tasks are performed in common by 50 percent or more of 5-skill level D-shred personnel indicates the jobs 27250D personnel perform do not differ significantly from each other.

DAFSC 27270D. Respondents with a duty AFSC of 27270D accounted for a little over one percent of the total survey population. There was not as noticeable a shift in job emphasis toward supervisory duties within the D-shred as was the case with 27270 personnel. However, 7-skill D-shred level personnel perform a higher average number of tasks than 5-skill level personnel (83 versus 99 respectively). It appears the majority of these additional tasks are supervisory in nature. A close analysis of the tasks 5- and 7-skill level D-shred personnel perform reveals they do the same basic job. However, a higher percentage of 7-skill level D-shred personnel perform the following additional supervisory tasks:

Supervise Combat Control Team Operators (AFSC 27250D)
 Prepare APRs
 Conduct assault zone surveys
 Direct combat control continuation training
 Prepare assault zone survey forms
 Plan work assignments
 Perform high altitude low opening (HALO) operations
 Supervise Apprentice Combat Control Team Operators (AFSC 27230D)
 Plan and coordinate combat control training missions
 Assign personnel to duty positions
 Coordinate combat control training areas
 Conduct combat control Phase III continuation training (CCT)
 Counsel personnel on personal or military related problems
 Schedule leaves or passes
 Conduct Drop Zone Control Officer Training

DAFSC 27299 - Air Traffic Control Superintendent

The survey population included 107 respondents with a duty AFSC of 27299. These personnel accounted for approximately five percent of the total sample. General background data for 9-skill level personnel are presented in Table 13. Overall, there is a shift from technical jobs at the 7-skill levels to a more supervisory role at the 9-skill level. This shift in emphasis from technical to supervisory duties is readily apparent in Table 7. However, it is interesting to note that even at this DAFSC level, almost a third of the group's total relative time is devoted to general Air Traffic Control, Control Tower, and Radar functions. These technical tasks include all the representative tasks listed under the 5- and 7-skill level cluster groups.

DAFSC 27299 personnel are more heterogeneous in terms of tasks performed. Although they perform a large number of tasks in common, none are performed by 90 percent or more of the personnel in this group. This appears to be due to the fact that there is considerable specialization according to Control Tower and Radar functions even at this DAFSC level - although not to the extent that it existed at the 3-, 5-, and 7-skill levels. Examples of representative tasks performed in common by 70 percent or more of these personnel include:

- Write general correspondence
- Evaluate facility letters of agreement
- Evaluate facility operation letters
- Interpret policies, directives, or procedures for subordinates
- Evaluate ATC problem areas
- Interpret ATC policies for using activities
- Evaluate facility memoranda
- Evaluate ATC methods or techniques
- Counsel personnel on personal or military related problems
- Evaluate compliance with performance standards
- Prepare and submit recommendations for improving and standardizing Air Traffic Control procedures

- Evaluate ATC recommendations
- Supervise Air Traffic Control Technicians (AFSC 27270)
- Prepare APRs
- Determine work priorities
- Assign personnel to duty positions
- Evaluate ATC complaints
- Conduct briefings on ATC procedures
- Conduct facility tours

CEM Code 27200 - Air Traffic Control Manager

Thirty-seven respondents, accounting for two percent of the total sample, indicated they held the 27200 CEM Code. These personnel were basically similar to DAFSC 27299 personnel (see Table 13). They differed in that they devoted slightly less of their total relative job time to general Air Traffic Control functions and slightly more relative job time to organizing and planning and inspecting and evaluating tasks (see Table 7). Examples of tasks which were performed by slightly higher percentages of 27200 personnel include:

- Supervise Air Traffic Control Superintendents (AFSC 27299)
- Establish organizational policies, office instructions (OI), or standard operating procedures (SOP)
- Maintain ATC liaison with other United States agencies
- Establish procedures for controlling traffic between sectors
- Direct Radar Approach Control (RAPCON) activities
- Prepare letters of agreement
- Plan facility equipment layouts
- Write staff studies, surveys, or special reports
- Conduct staff meetings
- Initiate corrective actions based on inspection deficiency reports
- Prepare job descriptions
- Evaluate inspection reports or procedures
- Establish procedures for controlling traffic between sectors and other facilities
- Investigate aircraft accidents or incidents
- Revise facility equipment layouts
- Develop organizational charts

DAFSC Summary

In general, examination of occupational data for DAFSC groups reflected a technical specialty with at least two major subareas of specialization--Control Tower and Radar. When viewed within these two areas, the picture emerges of progressively more technical DAFSC levels with considerable technical orientation at least up through the 9-skill level. In addition, 7- and 9-skill level personnel take on more supervisory and management responsibilities; these are generally performed in addition to a common core of tower or radar related technical tasks.

TABLE 5

PERCENT MEMBERS PERFORMING CAREER LADDER JOBS BY DAFSC GROUPS

JOB GROUPS	DAFSC 27230	DAFSC 27250	DAFSC 27270	DAFSC 27299	CEM CODE 27200
CONTROL TOWER PERSONNEL CLUSTER	48	38	30	0	0
RADAR ATC PERSONNEL CLUSTER	34	53	40	8	0
AIR TRAFFIC CONTROL SUPERVISORS CLUSTER	0	1	15	56	67
PAR SPECIALISTS IJT	4	1	2	0	0
LIMITED DUTY PERSONNEL IJT	2	1	*	0	0
MOBILE ATC PERSONNEL IJT	0	*	*	0	0
TERPs SPECIALISTS IJT	0	0	*	3	0
ATC ANALYSTS IJT	0	0	1	7	11
TECHNICAL SCHOOL INSTRUCTORS IJT	0	1	1	0	3

* INDICATES LESS THAN ONE PERCENT

TABLE 6

BACKGROUND INFORMATION FOR CONTROL TOWER CLUSTER PERSONNEL
(AFS 272X0)

	27230	27250	27270
PERCENT OF TOTAL SAMPLE	3%	17%	11%
PERCENT OF CLUSTER SAMPLE	10%	55%	35%
AVERAGE NUMBER OF TASKS PERFORMED	72	90	103
PERCENT WHO SUPERVISE OTHERS	2%	10%	83%
PERCENT ASSIGNED OVERSEAS	12%	19%	26%
<u>AREA IN WHICH CERTIFIED</u>			
NOT CERTIFIED	82%	5%	1%
AIR TRAFFIC REGULATION CENTER	0	0	1%
CONTROL TOWER	18%	94%	98%
GCA RADAR FINAL CONTROL	0	3%	7%
GROUND CONTROL APPROACH	2%	3%	6%
NONRADAR CENTER	0	0	2%
RADAR APPROACH CONTROL	0	1%	9%
RADAR CENTER	0	0	*
RADAR FINAL CONTROL	2%	3%	8%
RANGE CONTROL CENTER	0	0	0

* LESS THAN ONE PERCENT

TABLE 7

RELATIVE TIME SPENT ON DUTIES BY CONTROL TOWER (CT) AND RADAR ATC (RATC) CLUSTER DAFSC GROUPS,
DAFSC 27299, AND CEM CODE 27200 PERSONNEL
(PERCENT TIME SPENT)

DUTIES	CT (N=66)		CT (N=305)		CT (N=229)		RATC (N=47)		RATC (N=515)		RATC (N=313)		27299 (N=107)		CEM CODE 27200 (N=37)	
	54	53	31	3	27	2	58	52	44	20	27270 (N=107)	27299 (N=107)	27200 (N=37)			
PERFORMING GENERAL AIR TRAFFIC CONTROL FUNCTIONS	54	53	31	3	27	2	58	52	44	20	27270 (N=107)	27299 (N=107)	27200 (N=37)			
PERFORMING CONTROL TOWER FUNCTIONS	35	31	31	3	27	2	2	3	5	6	27270 (N=107)	27299 (N=107)	27200 (N=37)			
PERFORMING RADAR FUNCTIONS	3	3	3	3	2	2	34	32	26	6	27270 (N=107)	27299 (N=107)	27200 (N=37)			
WORKING WITH FORMS, RECORDS, REPORTS, DIRECTIVES AND TECHNICAL DATA	4	5	3	5	5	5	4	4	5	6	27270 (N=107)	27299 (N=107)	27200 (N=37)			
DIRECTING AND IMPLEMENTING	1	3	1	3	8	1	1	3	7	16	27270 (N=107)	27299 (N=107)	27200 (N=37)			
ORGANIZING AND PLANNING	1	1	1	1	3	3	*	1	3	15	27270 (N=107)	27299 (N=107)	27200 (N=37)			
TRAINING	*	3	3	3	7	7	*	3	7	11	27270 (N=107)	27299 (N=107)	27200 (N=37)			
INSPECTING AND EVALUATING	*	1	1	1	3	3	*	1	3	17	27270 (N=107)	27299 (N=107)	27200 (N=37)			
PERFORMING AIR TRAFFIC REGULATIONS CENTER (ATRC) FUNCTIONS	*	*	*	*	*	*	*	*	*	*	27270 (N=107)	27299 (N=107)	27200 (N=37)			
PERFORMING MOBILE OPERATIONS	*	*	*	*	*	*	*	*	*	*	27270 (N=107)	27299 (N=107)	27200 (N=37)			
PERFORMING COMBAT CONTROL OPERATIONS AND TRAINING	*	*	*	*	*	*	*	*	*	*	27270 (N=107)	27299 (N=107)	27200 (N=37)			

* INDICATES LESS THAN ONE PERCENT

TABLE 8
 TASKS PERFORMED IN COMMON BY 90 PERCENT OR MORE OF DAFSC 27270
 CONTROL TOWER CLUSTER PERSONNEL

TASK	PERCENT MEMBERS PERFORMING
ISSUE WHEELS DOWN ADVISORIES	100
ISSUE ALTIMETER SETTINGS	100
ISSUE TAXIING INSTRUCTIONS	98
ISSUE WAKE TURBULENCE ADVISORIES	98
OPERATE PRIMARY CRASH ALARM SYSTEMS	98
MAINTAIN SURVEILLANCE OF AIRPORT MOVEMENT AND TRAFFIC AREAS	97
CONTROL VEHICLES, EQUIPMENT, OR PERSONNEL IN MOVEMENT AREA USING RADIOS	97
SEQUENCE LANDING AIRCRAFT	97
ISSUE WIND ADVISORIES	97
RELAY AIRCRAFT ARRIVAL OR DEPARTURE TIMES	97
NOTIFY AGENCIES OF RUNWAYS IN USE	97
ACTIVATE BACKUP COMMUNICATION SYSTEMS	97
APPROVE OR DISAPPROVE TAKEOFFS	95
REQUEST AIRCRAFT RELEASES FROM DEPARTURE CONTROL	95
MAKE TIME CHECKS	95
OPERATE AIRFIELD APPROACH LIGHTING SYSTEMS	93
SEQUENCE DEPARTING AIRCRAFT	93
AUTHORIZE INTERSECTION TAKEOFFS	93
ISSUE WEATHER ADVISORIES	93
SEPARATE AIRCRAFT USING WAKE TURBULENCE PROCEDURES	93
APPROVE OR DISAPPROVE AIRCRAFT TAXIING	92
ISSUE AIRFIELD ADVISORIES	92
ASSIGN RUNWAYS FOR LANDINGS OR TAKEOFFS	90
ISSUE BIRD FLIGHT ADVISORIES	90
ACTIVATE EMERGENCY EVACUATION ALARM SYSTEMS	90
ADVISE PILOTS OF OBSERVED ABNORMAL AIRCRAFT CONDITIONS	90

TABLE 9
 BACKGROUND INFORMATION FOR RADAR AIR TRAFFIC CONTROL
 CLUSTER PERSONNEL
 (AFS 272X0)

	<u>27230</u>	<u>27250</u>	<u>27270</u>
PERCENT OF TOTAL SAMPLE	1%	18%	11%
PERCENT OF CLUSTER SAMPLE	5%	58%	35%
AVERAGE NUMBER OF TASKS PERFORMED	79	108	131
PERCENT WHO SUPERVISE OTHERS	0	20%	78%
PERCENT ASSIGNED OVERSEAS	17%	30%	27%
AREA IN WHICH CERTIFIED			
NOT CERTIFIED	64%	4%	4%
AIR TRAFFIC REGULATION CENTER	0	1%	3%
CONTROL TOWER	2%	19%	33%
GCA RADAR FINAL CONTROL	6%	20%	22%
GROUND CONTROL APPROACH	2%	19%	25%
NONRADAR CENTER	0	*	1%
RADAR APPROACH CONTROL	13%	66%	64%
RADAR CENTER	0	2%	2%
RADAR FINAL CONTROL	23%	62%	63%
RANGE CONTROL CENTER	0	1%	2%

*INDICATES LESS THAN ONE PERCENT

TABLE 10

TASKS PERFORMED IN COMMON BY 90 PERCENT OR MORE OF DAFSC 27250
RADAR AIR TRAFFIC CONTROL PERSONNEL

TASKS	PERCENT MEMBERS PERFORMING
ISSUE ALTIMETER SETTINGS	98
ISSUE WIND ADVISORIES	97
IDENTIFY AIRCRAFT USING TRANSPONDER METHODS	96
ISSUE WHEELS DOWN ADVISORIES	96
ISSUE MISSED APPROACH INSTRUCTIONS	96
CLEAN WORK AREAS OR EQUIPMENT	96
IDENTIFY AIRCRAFT USING PRIMARY RADAR METHODS	96
REQUEST AIRCRAFT ALTITUDE VERIFICATIONS	95
ISSUE WEATHER ADVISORIES	95
REPORT RADAR MALFUNCTIONS	95
PERFORM RADAR HANDOFFS	94
COORDINATE AIRCRAFT HANDOFFS	93
PERFORM INTERFACILITY COORDINATIONS	93
ASSIGN FREQUENCIES TO AIRCRAFT	93
MAKE TIME CHECKS	93
PROVIDE PRECISION RADAR APPROACHES	92
ADJUST RADAR SCOPES	92
PROVIDE RADAR SURVEILLANCE APPROACHES	92
ISSUE LOST COMMUNICATIONS INSTRUCTIONS	92
PROVIDE RADAR ASSISTANCE TO EMERGENCY AIRCRAFT	92
PERFORM INTRAFACILITY COORDINATIONS	91
ISSUE DECISION HEIGHT ALTITUDE ADVISORIES	91
ISSUE MINIMUM DESCENT ALTITUDE ADVISORIES	91
ISSUE BIRD FLIGHT ADVISORIES	91
REQUEST AIRCRAFT POSITION INFORMATION	90
ISSUE AIRCRAFT SPEED ADJUSTMENTS	90
OPERATIONALLY CHECK PRIMARY RADAR	89

TABLE 11
 RELATIVE TIME SPENT ON DUTIES BY COMBAT CONTROL TEAM OPERATIONS
 (272X0D) PERSONNEL

DUTIES	PERCENT TIME SPENT	
	27250D	27270D
ORGANIZING AND PLANNING	3	5
DIRECTING AND IMPLEMENTING	3	6
INSPECTING AND EVALUATING	1	2
TRAINING	4	6
WORKING WITH FORMS, RECORDS, REPORTS, DIRECTIVES AND TECHNICAL DATA	8	8
PERFORMING GENERAL AIR TRAFFIC CONTROL FUNCTIONS	19	15
PERFORMING RADAR FUNCTIONS	*	*
PERFORMING CONTROL TOWER FUNCTIONS	5	5
PERFORMING AIR TRAFFIC REGULATIONS CENTER (ATRC) FUNCTIONS	*	*
PERFORMING MOBILE OPERATIONS	7	7
PERFORMING COMBAT CONTROL OPERATIONS AND TRAINING	49	45

* INDICATES LESS THAN ONE PERCENT

TABLE 12

TASKS PERFORMED BY THE GREATEST PERCENTAGES OF 27250D RESPONDENTS

TASK	PERCENT MEMBERS PERFORMING
PACK PARACHUTES	100
PERFORM COMBAT CONTROL TEAM DEMOLITION OPERATIONS	100
INSPECT PARACHUTES	100
OPERATE PORTABLE COMMUNICATION EQUIPMENT	97
MARK ASSAULT ZONES	97
PERFORM STATIC LINE OPERATIONS	97
PERFORM OPERATOR MAINTENANCE ON WEAPON EQUIPMENT	97
PERFORM COMBAT CONTROL TEAM REPELLING TECHNIQUES	97
PERFORM COMBAT CONTROL TEAM ASSIGNED WEAPON TRAINING	97
CONFIGURE FIELD GEAR FOR AIR-LAND EMPLOYMENTS	94
CONDUCT JUMP MASTER INSPECTIONS	94
CONTROL ASSAULT ZONE OPERATIONS	91
CONFIGURE FIELD GEAR FOR PARACHUTE EMPLOYMENTS	91
PERFORM OPERATOR MAINTENANCE ON PARACHUTE EQUIPMENT	91
PERFORM COMBAT CONTROL TRAINING MISSIONS	91
PERFORM COMBAT CONTROL TEAM UNIT TACTICS OPERATIONS	91
CLEAN WORK AREAS OR EQUIPMENT	88
CONFIGURE COMMUNICATION EQUIPMENT FOR PARACHUTE EMPLOYMENTS	88
OPERATE PORTABLE NAVAID EQUIPMENT	88
INSTALL OR REPLACE PORTABLE COMMUNICATION EQUIPMENT AT ASSAULT ZONES	85
PERFORM SEMIANNUAL TACTICAL EMPLOYMENT TRAINING	85
PREPARE PARACHUTE LOG FORMS (AFTO FORM 391)	85
MAKE WEATHER OBSERVATIONS	79
OPERATE M-SERIES VEHICLES AND ASSOCIATED EQUIPMENT	70
PREPARE ASSAULT ASSESSMENT FORMS (MAC FORM 168)	64

TABLE 13

BACKGROUND INFORMATION FOR AIR TRAFFIC CONTROL SUPERINTENDENTS
(DAFSC 27299) AND CEM CODE 27200 PERSONNEL

	<u>27299</u>	<u>27200</u>
PERCENT OF TOTAL SAMPLE	5%	2%
AVERAGE NUMBER OF TASKS PERFORMED	145	149
PERCENT WHO SUPERVISE OTHERS	72%	78%
PERCENT ASSIGNED OVERSEAS	34%	27%
<u>AREA IN WHICH CERTIFIED</u>		
NOT CERTIFIED	11%	16%
AIR TRAFFIC REGULATION CENTER	3%	0
CONTROL TOWER	67%	62%
GCA RADAR FINAL CONTROL	22%	14%
GROUND CONTROL APPROACH	26%	14%
NONRADAR CENTER	3%	5%
RADAR APPROACH CONTROL	39%	43%
RADAR CENTER	8%	5%
RADAR FINAL CONTROL	30%	38%
RANGE CONTROL CENTER	2%	3%

ANALYSIS OF FIRST ENLISTMENT GROUPS

Since Air Force entry-level (3ABR) training has been focusing more on the tasks performed by incumbents in their first job and first enlistment, it is important to take a close look at the major kinds of jobs performed by these first job and first enlistment personnel. Figure 2 reflects the overall distribution of 272X0/D first enlistment personnel among the job groups identified in the career ladder structure. Almost 90 percent of these incumbents grouped within the Radar Air Traffic Control (44 percent) and Control Tower (45 percent) clusters. Only two percent were found in the Combat Control Team (272X0D) group.

The computer printout in Appendix B lists all 518 inventory tasks and the percentages of first enlistment personnel who perform each task in the total sample (TS IEL), Control Tower Personnel cluster (CT 1EL), Radar Air Traffic Control Personnel cluster (RC 1EL), and Combat Control Team Personnel cluster (CCT 1EL). This printout clearly illustrates those tasks which are performed in common and those tasks which are unique to each of the three groups.

Only nine very general tasks were performed by 30 percent or more of the first enlistment personnel in all three groups. These were:

- Activate backup communication systems
- Clean work areas or equipment
- Issue weather advisories
- Issue wheels down advisories
- Issue wind advisories
- Make weather observations
- Relay aircraft arrival or departure times
- Relay aircraft messages to other agencies

However, when the percentages of Control Tower and Radar Air Traffic Control Personnel were compared, 68 tasks were identified which were performed in common by 30 percent or more of the first enlistment personnel in both clusters. The majority of these (58 tasks) were tasks within the general Air Traffic Control duty (Duty F) or were general tasks under other duty headings (10 tasks). These 10 tasks are listed below:

- Conduct facility tours
- Supervise Apprentice Air Traffic Control Operators (AFSC 27230)
- Maintain training records, charts, or graphs
- Prepare outage 606 forms
- Prepare position log forms (AF Form 1134)
- Prepare traffic count forms
- Approve or disapprove clearances for pilots requests to conduct unusual maneuvers
- Inform agencies of observed unusual events or incidents
- Advise pilots of observed abnormal aircraft conditions
- Sequence landing aircraft

It is significant that general Air Traffic Control tasks were performed in common by both Control Tower and Radar Air Traffic Control first enlistment personnel. In view of the fact that there was little overlap between the two cluster groups in terms of technical Control Tower or Radar ATC tasks, a channelized training approach would merit consideration as it would appear to be more efficient and cost effective.

Finally, tasks performed by first enlistment Combat Control Team members were compared separately from tasks performed by members in the Control Tower and the Radar Air Traffic Control clusters. This comparison revealed Combat Control Team cluster personnel perform only those nine general tasks listed on the preceding page in common with Radar Air Traffic Control Personnel.

On the other hand, 30 percent or more of first enlistment Combat Control Team cluster personnel perform the following additional six tasks in common with first enlistment Control Tower cluster personnel:

- Assign runways for landings or takeoffs
- Control aircraft using light gun signals
- Control vehicles, equipment, or personnel in movement area using light gun signals
- Control vehicles, equipment or personnel in movement area using radios
- Operate rotating beacons
- Sequence departing aircraft

Obviously, Combat Control Personnel perform few tasks in common with the other two cluster groups. They perform only 15 tasks in common with Tower Control cluster personnel and only nine very general tasks in common with Radar Air Traffic Control Cluster Personnel. This absence of overlap should be given careful consideration in any analysis of current 272X0D training.

FIGURE 2

DISTRIBUTION OF FIRST ENLISTMENT PERSONNEL ACROSS CAREER LADDER JOBS
(PERCENT MEMBERS RESPONDING)

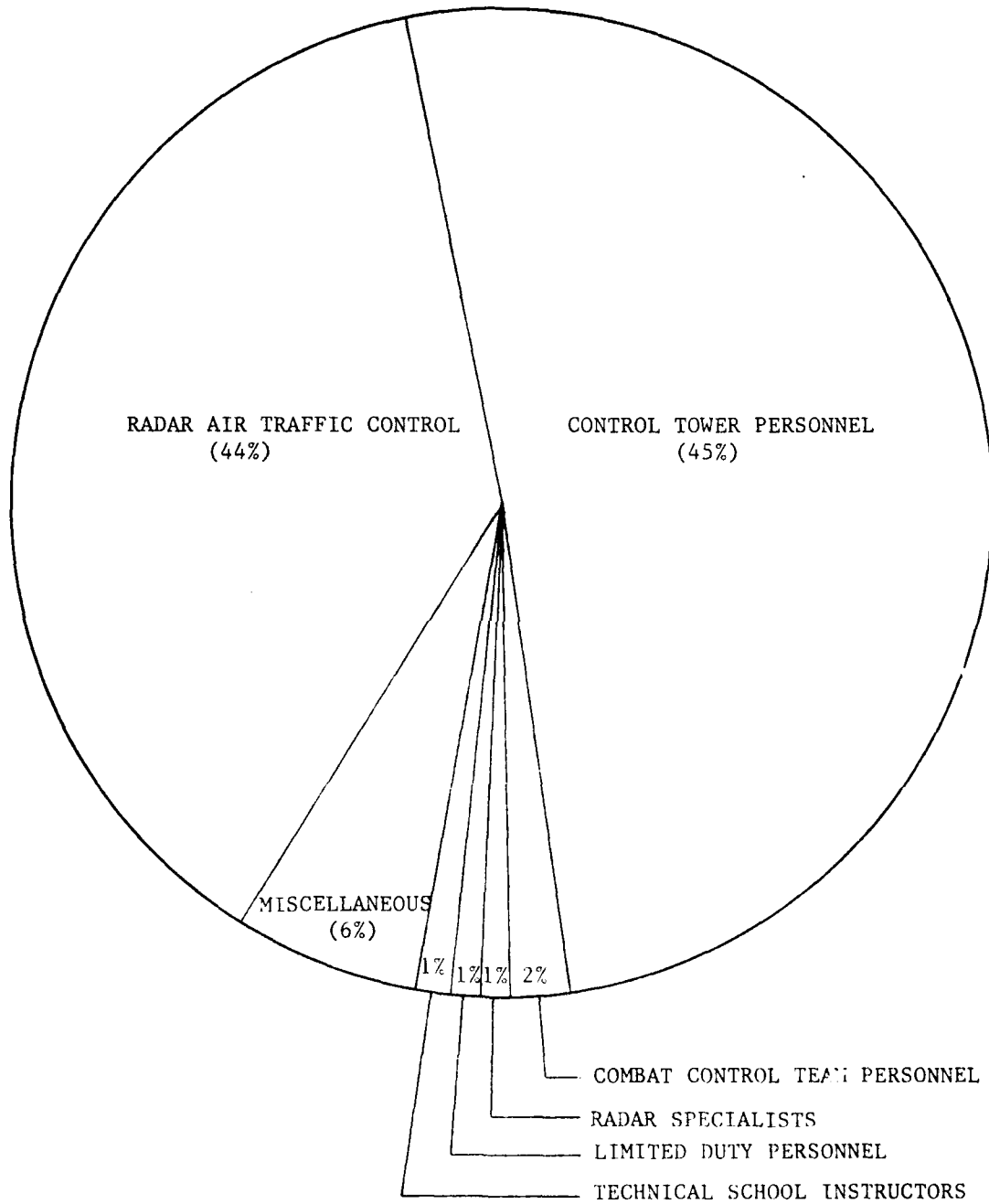

ANALYSIS OF CAREER LADDER DOCUMENTS

AFR 39-1 Specialty Descriptions

A comparison was made of the AFR 39-1 specialty descriptions for the Air Traffic Control specialty with skill level DAFSC data to determine the accuracy of these descriptions. The survey data were compared against the descriptions of the Air Traffic Control Operator (30 April 1978), Air Traffic Control Technician, and Air Traffic Control Superintendent (30 October 1978).

Overall, the AFR 39-1 specialty descriptions are accurate and comprehensive overviews of the job functions performed by Air Traffic Control and Combat Control Team personnel. The present Air Traffic Control Operator format of a separate paragraph for each of the functional areas listed below is an excellent break down of the kinds of tasks Air Traffic Control personnel perform:

- a. Controls and regulates en route and terminal air traffic.
- b. Operates en route air traffic control facilities.
- c. Operates Approach Control, GCA, and Radar Final Control (RFC) facilities.
- d. Establishes Air Traffic Control facility on assault landing zones when performing Combat Control Team operations duties.
- e. Operates Control Tower facilities.
- f. Supervises Air Traffic Control personnel

The Air Traffic Control Technician specialty description might be more accurate if more specific paragraphs were added to cover the tasks performed in conjunction with Approach Control, GCA, Radar Final Control, and Control Tower facilities. The present AFR 39-1 description gives the impression 27270 personnel perform few technical tasks. This is true of some; however, the data show AFSC 27270 personnel devote over half of their total relative time to nonsupervisory tasks within the General Air Traffic Control, Radar, or Control Tower duties. Therefore, the job description could be made more representative by including a more complete description of their duties.

Finally, as previously mentioned in the career ladder structure section, Combat Control Team (CCT) personnel perform few tasks in common with other AFSC 272X0 personnel. At present, AFCC and MAC are in agreement that the 272X0D shred should be deleted from the AFSC and assigned a specialty code of its own. In view of the fact that the job of the Combat Controller is so unique, there is nothing in the data which would preclude this action. If a new AFSC is created, the STS description could be streamlined to more accurately reflect CCT functions.

Specialty Training Emphasis

Survey data were compared to the December 1979 272X0 STS and the July 1979 272X0D STS. Both STSs were reviewed by subject matter specialists at the Keesler Technical Training Center, who matched all applicable inventory tasks with STS paragraphs. On the basis of these matchings, each

STS subparagraph containing task knowledge or performance requirements was compared to the survey results. The results of these comparisons are presented below:

STS 272X0. The STS for the 272X0 career ladder appeared complete in providing for general training requirements. Some of the more unique and a few emergency STS items were performed by only small percentages of personnel. However, the vast majority of STS paragraphs were supported by the data in terms of percent members performing tasks.

Only one item concerning mobile Air Traffic Control functions was noted for possible addition. Although only a very small percentage of 272X0 personnel perform Mobile Air Traffic Control functions, there is no STS paragraph which covers this area. Subject matter specialists should examine the Mobile Air Traffic Control related tasks to determine whether they should be included in the STS.

STS 272X0D. On the basis of the 272X0D STS match, the document could be streamlined by eliminating most Radar and Air Traffic Regulation Center (ATRC) functions. Many tasks relating to these functional areas are not performed by 272X0D personnel. The computer printout in Appendix B presents the inventory items which were matched to 272X0D STS items. Those inventory items which were not referenced to STS items appear at the back of the printout. Observe that (1) most Radar and ATRC tasks were not referenced to STS items and (2) most of the Radar and ATRC tasks were not performed by members of the 272X0D sample.

No doubt, further refinements to the 272X0D STS could be made using the data in this computer printout. However, these should be accomplished through review by experienced CCT subject matter specialists.

Training Documents

The current E3ABR27230 Plan of Instruction (POI) was also reviewed in a general sense against the survey data. Overall, 272X0 training appears to be relevant and is generally supported by survey data. However, the data indicate 272X0 training could be made more relevant and cost effective if personnel were channelized from a common course into a Control Tower or a Radar Control Course. Of course, this approach would limit the flexibility of both MPC and the individual Unit Commander in terms of assignments.

As previously mentioned, Combat Control Team personnel perform few Radar or ATRC functions. These aspects of the E3ABR27230 Course are not relevant to their job.

Technical School Data

Computer products similar to that in Appendix B have been provided to technical school personnel. These products can be extremely useful in fine tuning training programs and can help bring training in line with proposed Combat Control Team AFR 39-1 and STS changes, should they be approved.

ANALYSIS OF TASK DIFFICULTY

The relative difficulty of each task in the inventory was assessed by 52 experienced 7- and 9-skill level Air Traffic Control NCOs. Unfortunately, a combination of inadequate returns and a lack of agreement among AFSC 272X0D raters precluded a task difficulty analysis of Combat Control Team tasks. However, the AFSC 272X0 ratings were processed to produce an ordered listing of all tasks in terms of their relative difficulty and were standardized to reflect an average difficulty of 5.0 and a standard deviation of 1.0 (for a more complete description of these ratings, refer to the Task Factor Administration section in the INTRODUCTION).

Table 14 lists those tasks rated most difficult by senior 272X0 personnel in the field. Most of these more difficult tasks were supervisory in nature or required very specialized expertise. Clearly, the most difficult task in the inventory involved the preparation and submission of Terminal Instrument Procedure (TERPs) Packages.

Table 15 indicates that this mix of supervisory and technical tasks continues down through those tasks rated average in difficulty. However, the supervisory tasks listed here were more specific and generally involved a more limited span of control. Likewise, the technical tasks of average difficulty were more routine general or Radar Air Traffic Control related tasks.

Table 16 lists those tasks rated least difficult by senior 272X0 personnel. These were primarily routine general Air Traffic Control, Tower, or administrative tasks.

In summary, the tasks rated most difficult to perform were primarily supervisory or highly technical. Since few of these most difficult tasks were performed by more than 10 percent of 272X0 personnel, they were very specialized in nature. Tasks rated average in difficulty included both supervisory and technical functions. However, most of the supervisory tasks involved very specialized methods, procedures, or programs which required limited supervision. On the other hand, the technical tasks of average difficulty consisted of both specialized and common tasks. Finally, those tasks rated least difficult were all routine general Air Traffic Control or administrative functions. The majority of these tasks were performed by over 50 percent of all 272X0 personnel.

TABLE 14

REPRESENTATIVE TASKS RATED MOST DIFFICULT BY 272X0 RESPONDENTS

TASK	TASK DIFFICULTY	PERCENT MEMBERS PERFORMING	
		TOTAL SAMPLE	FIRST ENLISTMENT
PREPARE AND SUBMIT TERMINAL INSTRUMENT PROCEDURE (TERPS) PACKAGES	8.24	5	1
DIRECT RADAR APPROACH CONTROL (RAPCON) ACTIVITIES	7.94	18	10
DIRECT CONVENTIONAL AIR ROUTE TRAFFIC CONTROL ACTIVITIES	7.79	4	3
DIRECT RADAR AIR ROUTE TRAFFIC CONTROL ACTIVITIES	7.72	3	2
INVESTIGATE AIRCRAFT ACCIDENTS OR INCIDENTS	7.59	3	1
REVIEW TERPS PACKAGES	7.58	6	1
DIRECT AIR TRAFFIC REGULATION CENTER (ATRC) ACTIVITIES	7.50	1	1
DIRECT NONRADAR APPROACH CONTROL ACTIVITIES	7.34	12	8
PREPARE TERPS PACKAGES FOR MOBILE SITE DEVELOPMENT	7.26	1	*
PREPARE LETTERS OF AGREEMENT	7.24	4	1
PACK PARACHUTES	7.14	1	*
COORDINATE REVISIONS FOR SPECIAL OPERATIONS WITH FEDERAL AVIATION ADMINISTRATION (FAA) CENTERS	7.04	5	4
PERFORM CONVENTIONAL APPROACH CONTROL PROCEDURES	7.12	1	1
WRITE STAFF STUDIES, SURVEYS, OR SPECIAL REPORTS	7.06	5	1
DIRECT INSTRUMENT METEOROLOGICAL CONDITION (IMC) APPROACH CONTROL TOWER ACTIVITIES	7.03	2	1
SUPERVISE APPRENTICE AIR TRAFFIC CONTROL OPERATORS (AFSC 27230)	6.98	49	29
DRAFT BUDGETS OR FINANCIAL REQUIREMENTS	6.78	5	1
AUTHORIZE SIMULTANEOUS OPPOSITE DIRECTION OPERATIONS	6.78	28	28
CONDUCT SITE SURVEYS FOR LOCATING MOBILE NAVIGATIONAL AIDS EQUIPMENT	6.78	1	1
PREPARE AND SUBMIT RECOMMENDATIONS FOR IMPROVING AND STANDARDIZING AIR TRAFFIC CONTROL PROCEDURES	6.76	20	7
SUPERVISE APPRENTICE COMBAT CONTROL TEAM OPERATORS (AFSC 27230D)	6.71	3	3
ADMINISTER FACILITY RATING EXAMINATIONS	6.69	10	2
PREPARE RECOMMENDATIONS FOR CHANGES TO NAVIGATIONAL AIDS (NAVAID) TO BASES OR OTHER AGENCIES	6.68	2	1

*INDICATES LESS THAN ONE PERCENT

TABLE 15

REPRESENTATIVE TASKS RATED AVERAGE IN DIFFICULTY BY 272XO RESPONDENTS

TASK	TASK DIFFICULTY	PERCENT MEMBERS PERFORMING	
		TOTAL SAMPLE	FIRST ENLISTMENT
GIVE CLEARANCES OR NONCLEARANCES FOR ARRIVING AIRCRAFT	5.06	44	46
ADVISE AIRSPACE CONTROL CENTER (ACC) BRANCHES OF CHANGES TO OPERATING PROCEDURES	5.06	1	1
APPROVE OR DISAPPROVE ENROUTE ALTITUDE RESERVATIONS	5.06	7	10
IMPLEMENT COST REDUCTION PROGRAMS	5.05	3	2
REVIEW OPERATION ORDERS OR PLANS	5.05	1	1
CONTROL AND SEPARATE ARRIVING AIRCRAFT USING PRECISION APPROACH RADAR (PAR)	5.03	49	41
CONDUCT WEAPONS PROFICIENCY TRAINING OTHER THAN COMBAT CONTROL	5.02	1	1
DIRECT DEVELOPMENT OR MAINTENANCE OF STATUS BOARDS, GRAPHS, OR CHARTS	5.02	7	3
CONDUCT BRIEFINGS FOR NEWLY ASSIGNED PILOTS ON LOCAL ATC POLICIES AND PROCEDURES	5.02	17	8
EVALUATE PROCEDURES FOR STORAGE, INVENTORY, OR INSPECTION OF PROPERTY ITEMS	5.01	2	1
ISSUE OR TRANSMIT ENROUTE CLEARANCES USING INTERNATIONAL CIVIL AVIATION ORGANIZATION (ICAO) PROCEDURES	5.00	11	9
ISSUE IFR HOLDING INSTRUCTIONS	5.00	44	43
PREPARE OR REVIEW SERVICE EVALUATION REPORTS	5.00	8	2
ISSUE AIRCRAFT SPEED ADJUSTMENTS	4.99	50	47
PROCURE TRAINING AIDS, SPACE, OR EQUIPMENT	4.99	10	3
PROVIDE PRECISION RADAR APPROACHES	4.99	52	45
COMPILE FLIGHT MANAGEMENT/TRAINING/EVALUATION RECORDS FORMS (AF FORM 846)	4.98	1	1
ISSUE TACC GUIDANCE TO CONTROLLER ON USE OF AIRSPACE OR CONTROL PROCEDURES	4.97	*	*
AUTHORIZE PARACHUTE OR AIRDROP OPERATIONS	4.96	14	13
DETERMINE WORK PRIORITIES	4.95	27	12
COORDINATE AIR TRAFFIC CONTROL (ATC) PROCEDURES FOR DISASTER CONTROL EXERCISES WITH OTHER AGENCIES	4.95	17	11
PLAN SECURITY PROGRAMS	4.95	3	1
PROVIDE SPECIAL HANDLING FOR VERY IMPORTANT PERSONS (VIP) TRAFFIC	4.94	46	49
ARRANGE FOR WEATHER INFORMATION IN SUPPORT OF MOBILE OPERATIONS WITH WEATHER AGENCIES	4.94	1	*
ESTABLISH PUBLICATION LIBRARIES	4.94	7	3

*INDICATES LESS THAN ONE PERCENT

TABLE 16

REPRESENTATIVE TASKS RATED LEAST DIFFICULT BY 272X0 PERSONNEL

TASK	TASK DIFFICULTY	PERCENT MEMBERS PERFORMING	
		TOTAL SAMPLE	FIRST ENLISTMENT
RELAY AIRCRAFT MESSAGES TO OTHER AGENCIES	3.36	72	78
PERFORM RUNWAY CHECKS	3.36	10	10
ASSIGN PERSONNEL TO DUTY POSITIONS	3.33	37	3
REQUEST AIRCRAFT POSITION INFORMATION	3.31	73	79
REQUEST AIRCRAFT ALTITUDE VERIFICATIONS	3.23	61	65
PERFORM OPERATIONAL CHECKS ON ATIS	3.21	28	29
OPERATE WEATHER RECEIVING EQUIPMENT	3.15	66	59
ASSIGN TRANSPONDER MODES AND CODES	3.13	66	64
SELECT APPROPRIATE WIND SENSORS	3.06	37	37
ASSIGN FREQUENCIES TO AIRCRAFT	3.05	80	82
ISSUE WHEELS DOWN ADVISORIES	3.04	89	91
FILE FLIGHT PROGRESS STRIPS	3.04	71	77
SCORE TESTS	2.99	13	3
ISSUE WIND ADVISORIES	2.99	88	92
RELAY AIRCRAFT ARRIVAL OR DEPARTURE TIMES	2.84	74	80
ISSUE ALTIMETER SETTINGS	2.76	90	93
REPLACE VOICE RECORDER TAPES	2.75	63	64
PREPARE POSITION LOG FORMS (AF FORM 1134)	2.50	67	63
OPERATE ROTATING BEACONS	2.40	42	44
REMOVE OR REPLACE TELEAUTOWRITER PAPER	2.28	80	83
NOTIFY AGENCIES OF RUNWAYS IN USE	2.18	75	78
ASSIGN SPONSORS FOR NEWLY ASSIGNED PERSONNEL	1.97	7	2
CLEAN WORK AREAS OR EQUIPMENT	1.93	86	94
MAKE TIME CHECKS	1.82	87	90

JOB DIFFICULTY INDEX (JDI)

Table 17 lists the ten major job groups identified in the CAREER LADDER STRUCTURE section. These are listed in order from the most difficult to the least difficult job according to their computed JDI (See the Administration section in the INTRODUCTION for a detailed description of the Job Difficulty Index). Overall, there is a large degree of variation in the difficulty of jobs performed by 272X0/D personnel. JDI values range from 3.8 for limited duty personnel to 21.4 for Air Traffic Control Supervisors (Average JDI Value = 13.0).

The average number of tasks performed is heavily weighted in the formula used to derive the JDI. Consequently, several of the jobs which are at or below the JDI mean (Air Traffic Control Analysts, Terps specialists, and Tech School Instructors) may be more difficult in terms of the tasks they perform than the JDI reflects. However, since they specialize in these areas and do not perform a large average number tasks, these jobs do not receive high JDI ratings.

Therefore, the overall spectrum of jobs within the ladder in terms of difficulty may not appear realistic. However, when broken down into separate groups of cluster and independent job type groups, a clearer picture emerges.

According to JDI ratings, the ATC Supervisors perform a very difficult job whereas Combat Control Team, Radar Air Traffic Control, and Control Tower personnel perform jobs which are about average in terms of job difficulty. However, the average task difficulty per unit of time spent (ATDPUTS) ratings indicate a different split. They indicate both the CCT and supervisory jobs are more difficult in comparison to the radar and tower control jobs. (This is due to the fact that the ATDPUT rating does not give additional weight to the number of tasks performed).

Consequently, very different picture emerges when the independent job groups are looked at in terms of ATDPUTS. Although none of the IJT groups received a higher JDI rating than the Air Traffic Control Supervisors cluster, three jobs (Terps Specialists, Air Traffic Control Analysts, and Technical School Instructors) had higher ATDPUTS values. This indicates the tasks these personnel perform are generally more difficult than those performed by other job groups. However, since they specialize in their respective areas and perform few other tasks, they received lower JDI ratings.

However, there can be no doubt concerning the least difficult jobs identified. Both the ATDPUTS and JDI values indicate the PAR Specialists and Limited Duty Personnel perform jobs with the lowest calculated difficulty values.

TABLE 17

AIR TRAFFIC CONTROL JOBS IN ORDER OF JOB DIFFICULTY INDEX (JDI)

GROUP	JDI*	AVERAGE NUMBER OF TASKS PERFORMED	AVERAGE TASK DIFFICULTY PER UNIT OF TIME SPENT (ATDPUTS)
AIR TRAFFIC CONTROL SUPERVISORS CLUSTERS	21.4	194	4.9
CCT PERSONNEL CLUSTER	14.7	89	5.0
TERPS SPECIALISTS IJT	13.9	49	5.6
RADAR AIR TRAFFIC CONTROL PERSONNEL CLUSTER	13.8	115	4.4
AIR TRAFFIC CONTROL ANALYSTS IJT	12.1	25	5.8
CONTROL TOWER PERSONNEL CLUSTER	11.1	93	4.2
TECHNICAL SCHOOL INSTRUCTORS IJT	8.8	26	5.1
MOBILE AIR TRAFFIC CONTROL PERSONNEL IJT	5.9	21	4.7
PAR SPECIALISTS IJT	5.0	38	4.1
LIMITED DUTY PERSONNEL IJT	3.8	32	4.0

* RELATIVE JOB DIFFICULTY OF 272X0/D JOBS AS PREDICTED USING A FORMULA DEVELOPED BY RESEARCH OF THE AIR FORCE HUMAN RESOURCES LABORATORY. AVERAGE JOB DIFFICULTY (MEAN) IS SET AT 13.0.

ANALYSIS OF TRAINING EMPHASIS

The relative training emphasis of each task in the inventory was assessed using the ratings of 45 experienced 7- and 9-skill level Air Traffic Control NCOs, and 13 Combat Control Team NCOs. These ratings were processed separately and resulted in two ordered listings of tasks in terms of recommended emphasis in the training of first enlistment personnel. The results of the training emphasis analysis are particularly useful in evaluating specialty training documents such as the Specialty Training Standard (STS) and the career ladder Plan of Instruction (POI). (For a more complete description of training emphasis ratings, refer to the Task Factor Administration section in the INTRODUCTION).

AFSC 272X0 Training Emphasis

Table 18 lists those tasks rated highest, in training emphasis by 7- and 9-skill level 272X0 personnel. Overall, the ratings showed a mean of 2.6 and a standard deviation of 2.3. Referencing Table 18, notice the majority of those tasks rated highest in training emphasis involved common Radar, Tower, and general Air Traffic Control tasks. Most of these tasks were average in terms of task difficulty and were performed in common to a greater or lesser extent by all 3-, 5-, and 7-skill level personnel.

Table 19 lists those tasks rated average in training emphasis. Generally, these are either supervisory or very specialized kinds of tasks which are seldom performed by over 10 percent of first enlistment personnel.

AFSC 272X0D Training Emphasis

The analysis of the Combat Control Team (CCT) training emphasis ratings showed little in common with the air traffic control training emphasis ratings. The CCT ratings reflect a mean of 2.09 and a standard deviation of 2.03. Most of the tasks rated highest in training emphasis involve preparing for deployment, getting to, and securing an assault zone (see Table 20). Obviously, air traffic control is not the only skill which is of critical importance in terms of needed training for these personnel.

A listing of those tasks rated average in training emphasis is shown in Table 21. The majority of these tasks are supervisory, training, or general air traffic control oriented tasks. For the most part, the only tasks of average training emphasis which are performed by over 20 percent of first enlistment personnel are general air traffic control tasks.

Summary

Training emphasis information can be a valuable tool in terms of training development as it gives the 7- and 9-skill level supervisor in the field the opportunity to indicate which tasks should receive the most emphasis in training. Ideally, training managers should use this information along with

the task difficulty ratings as additional guidelines to assist them in determining which areas should be covered in their specific course of instruction. Tasks which are more difficult to learn generally require more training time than tasks which are rated as less difficult. Those tasks with higher training emphasis ratings should be considered for initial ABR training, unless other factors indicate otherwise, (i.e., low percent members performing, low task difficulty, or lack of course resources). When these situations arise, some alternate form of training such as OJT, FTD, or MTT is often the best solution.

Tasks rated average in training emphasis should also be reviewed in the same light to determine the most suitable method of training for the specific tasks. Generally those tasks rated 1.0 or below on the training emphasis scale do not normally require training in formal ABR courses; however, they should not be completely ignored. Careful consideration should be given to the factors previously mentioned which may indicate that training is appropriate.

TASKS RATED HIGHEST IN TRAINING EMPHASIS BY 272XO PERSONNEL

TASK	TRAINING EMPHASIS	PERCENT MEMBERS PERFORMING	
		TOTAL 272XO	272XO FIRST ENLISTMENT
ADJUST RADAR SCOPES	7.53	63	59
ISSUE WAKE TURBULENCE ADVISORIES	7.13	84	84
ISSUE MISSED APPROACH INSTRUCTIONS	7.09	68	70
COORDINATE AIRCRAFT HANDOFFS	7.07	61	59
IDENTIFY AIRCRAFT USING TRANSPONDER METHODS	7.07	52	49
IDENTIFY AIRCRAFT USING PRIMARY RADAR METHODS	7.04	54	51
PROVIDE PRECISION RADAR APPROACHES	7.00	52	43
SEQUENCE LANDING AIRCRAFT	6.96	55	59
ISSUE WEATHER ADVISORIES	6.93	87	89
RELAY IFR CLEARANCES	6.91	76	78
PERFORM RADAR HANDOFFS	6.89	51	48
APPROVE OR DISAPPROVE TAKEOFFS	6.87	50	54
SEPERATE AIRCRAFT USING WAKE TURBULENCE PROCEDURES	6.84	77	78
CONTROL AND SEPERATE ARRIVING AIRCRAFT AIRCRAFT USING PRECISION APPROACH RADAR (PAR)	6.82	49	41
ISSUE WIND ADVISORIES	6.80	88	92
ISSUE IFR HOLDING INSTRUCTIONS	6.78	44	43
SEQUENCE DEPARTING AIRCRAFT	6.78	48	50
PERFORM INTERFACILITY COORDINATIONS	6.73	83	83
MAINTAIN SURVEILLANCE OF AIRPORT MOVEMENT AND TRAFFIC AREAS	6.69	46	48
PERFORM INTRAFACILITY COORDINATIONS	6.69	80	80
AUTHORIZE SPECIAL VISUAL FLIGHT RULES (VFR) OPERATIONS	6.67	54	55
OPERATIONALLY CHECK PRIMARY RADAR	6.60	49	53
AUTHORIZE SIMULTANEOUS OPPOSITE DIRECTION OPERATIONS	6.60	28	28
ACTIVATE BACKUP COMMUNICATION SYSTEMS	6.58	75	72
MONITOR AIRCRAFT DEPARTURES ON RADAR	5.98	46	45

TABLE 19

TASKS RATED AVERAGE IN TRAINING EMPHASIS BY 272XO PERSONNEL

TASK	TRAINING EMPHASIS	PERCENT MEMBERS PERFORMING	
		TOTAL 272XO	272XO FIRST ENLISTMENT
DIRECT PROCEDURES FOR PERFORMING EQUIPMENT CHECKS	2.91	19	8
PREPARE AIR TRAFFIC CONTROLLER EVALUATION RECORD FORMS	2.91	23	8
RELAY NOTIFICATIONS OF GROUND MISSILE EMERGENCIES	2.84	4	3
DIRECT NONRADAR APPROACH CONTROL ACTIVITIES	2.82	12	8
INITIATE SPECIAL EMERGENCY HANDLING PROCEDURES FOR CODED CALL SIGNS	2.80	12	13
DIRECT GROUND CONTROLLED APPROACH (GCA) ACTIVITIES	2.78	10	5
DIRECT VISUAL METEOROLOGICAL CONDITIONS (VMC) CONTROL TOWER ACTIVITIES	2.78	17	7
PREPARE AND SUBMIT RECOMMENDATIONS FOR IMPROVING AND STANDARDIZING AIR TRAFFIC CONTROL PROCEDURES	2.76	21	7
PREPARE APRs	2.76	36	2
CONDUCT ATC FACILITY SELF-INSPECTIONS	2.73	18	4
WRITE TRAINING REPORTS	2.73	22	11
OPERATE GENERATORS	2.73	24	19
PERFORM RUNWAY CHECKS	2.73	10	10
SUPERVISE AIR TRAFFIC CONTROL OPERATORS (AFSC 27250)	2.71	42	8
AUTHORIZE VFR AIRCRAFT TO CROSS JET ADVISORY AREAS	2.67	11	12
DIRECT RADAR APPROACH CONTROL (RAPCON) ACTIVITIES	2.64	18	10
DETERMINE OJT TRAINING REQUIREMENTS	2.60	15	3
PERFORM SAFETY CHECKS ON ELECTRICAL EQUIPMENT	2.53	13	9
PROVIDE RADAR SEPARATIONS IN EN ROUTE ENVIRONMENTS	2.49	2	3
PREPARE AND INITIATE USAF HAZARD REPORT FORMS (AF FORM 457)	2.47	13	3
COORDINATE AIRCRAFT MOVEMENT AND IDENTIFICATION INFORMATION WITH AIR DEFENSE COMMAND (ADC)	2.47	6	5
CALCULATE EN ROUTE AIRCRAFT POSITION ESTIMATES	2.42	10	10
ISSUE OR TRANSMIT EN ROUTE CLEARANCES USING HOST NATION AGREEMENT PROCEDURES	2.42	9	5
EVALUATE TRAINING METHODS OR TECHNIQUES	2.40	17	5
ESTABLISH PROCEDURES FOR NOTIFYING OTHER AGENCIES OF EQUIPMENT FAILURES	2.38	9	6
WRITE GENERAL CORRESPONDENCE	2.33	15	4

TABLE 20

TASKS RATED HIGHEST IN TRAINING EMPHASIS BY 272X0D PERSONNEL

TASK	TRAINING EMPHASIS	PERCENT MEMBERS PERFORMING	
		TOTAL 272X0D	272X0D FIRST ENLIST
PACK PARACHUTES	8.08	69	52
CONTROL ASSAULT ZONE OPERATIONS	7.92	65	48
PERFORM COMBAT CONTROL TEAM DEMOLITION OPERATIONS	7.92	71	52
PERFORM COMBAT CONTROL TEAM UNIT TACTICS OPERATIONS	7.92	64	40
PERFORM STATIC LINE OPERATIONS	7.92	71	60
RENDER COMBAT FIRST AID	7.77	50	32
CONDUCT JUMP MASTER INSPECTIONS	7.69	67	52
OPERATE PORTABLE COMMUNICATION EQUIPMENT	7.54	70	52
PERFORM LAND NAVIGATION PROFICIENCY TRAINING	7.54	62	44
PREPARE ASSAULT ASSESSMENT FORMS (MAC FORM 168)	7.38	51	28
CONFIGURE FIELD GEAR FOR PARACHUTE EMPLOYMENTS	7.15	61	44
MARK ASSAULT ZONES	7.15	69	52
INSPECT PARACHUTES	7.00	66	52
OPERATE PORTABLE NAVAID EQUIPMENT	7.00	61	44
PERFORM COMBAT CONTROL TRAINING MISSIONS	7.00	64	44
PERFORM ESCAPE AND EVASION TECHNIQUES	7.00	55	40
PREPARE PARACHUTE LOG FORMS (AFTO FORM 391)	6.92	58	48
CONFIGURE COMMUNICATION EQUIPMENT FOR PARACHUTE EMPLOYMENTS	6.92	62	48
PERFORM COMBAT CONTROL TEAM REPELLING TECHNIQUES	6.92	69	56
PERFORM OPERATOR MAINTENANCE ON WEAPON EQUIPMENT	6.85	60	52
PERFORM SEMIANNUAL TACTICAL EMPLOYMENT TRAINING	6.85	59	44
PREPARE PARACHUTE REPACK, INSPECTION, AND COMPONENT RECORD FORMS (AFTO FORM 392)	6.77	55	48
CONTROL EXTRACTION ZONE OPERATIONS	6.77	46	36
INSTALL OR REPLACE PORTABLE COMMUNICATION EQUIPMENT AT ASSAULT ZONES	6.77	63	48
PERFORM OPERATOR MAINTENANCE ON PARACHUTE EQUIPMENT	6.77	58	44

TASKS RATED AVERAGE IN TRAINING EMPHASIS BY 272X0D PERSONNEL

TASK	TRAINING EMPHASIS	PERCENT MEMBERS PERFORMING	
		TOTAL 272X0D	272X0D FIRST ENLIST
ESTABLISH PERFORMANCE STANDARDS FOR SUBORDINATES	2.23	24	8
IMPLEMENT SAFETY PROGRAMS	2.23	14	4
ASSIGN FREQUENCIES TO AIRCRAFT	2.23	34	40
ESTABLISH PROCEDURES FOR CONTROLLING TRAFFIC BETWEEN SECTORS	2.15	5	0
CONDUCT BRIEFINGS ON NEW TRAINING TECHNIQUES	2.15	14	4
RELAY MEACONING, INTRUSION, AND JAMMING INTERCEPT (MIJI) INFORMATION	2.15	15	24
RECORD AND DEPICT HOSTILE FIRE LOCATIONS	2.15	6	4
COUNSEL TRAINEES ON TRAINING PROGRESS	2.15	41	16
COORDINATE AIRCRAFT HANDOFFS	2.08	27	29
ESTABLISH PRIORITIES FOR RESTORING EQUIPMENT	2.00	12	0
ESTABLISH PROCEDURES FOR NOTIFYING OTHER AGENCIES OF EQUIPMENT FAILURES	2.00	9	4
PLAN SECURITY PROGRAMS	2.00	10	4
CONDUCT FACILITY TOURS	2.00	31	22
SUPERVISE COMBAT CONTROL TEAM OPERATORS (AFS 272500)	2.00	44	8
ACTIVATE BACKUP ELECTRICAL POWER SYSTEMS	2.00	17	20
RELAY INFORMATION FOR ISSUANCE OF TAKEOFF/NOTICE TO AIRMEN (NOTAMS)	2.00	16	24
INTERPRET FRAG ORDERS	2.00	6	0
CONDUCT SITE SURVEYS FOR LOCATING HOSTILE AND/OR ALLIED AIDS EQUIPMENT	2.00	13	8
ESTABLISH STUDY REFERENCE FILES	1.92	14	0
FILE OBSERVED ROCKET OR ARTILLERY FIRE REPORTS	1.92	5	0
MAINTAIN MEDICAL RECOMMENDATION FOR FLYING OR SPECIAL OPERATIONS DUTY FORMS (AF FORM 1047)	1.92	16	
FORMULATE IFR CLEARANCES	1.92	20	24
REGULATE FLOW OF TRAFFIC BETWEEN SECTIONS OF FACILITIES	1.92	11	12
SUPPORT MINIMUM INTERVAL TAKEOFF OPERATIONS (MTO)	1.92	15	24
REVIEW HOSTILE FIRE LOCATION BOARDS	1.92	1	0

CONUS - OVERSEAS COMPARISONS

Air Traffic Control - DAFSC 27250

The survey sample contained 963 personnel with a duty AFSC of 27250. Of these respondents, 720 or 75 percent were assigned to CONUS locations. Table 22 contains information on a number of background items for CONUS and overseas personnel in the Air Traffic Control ladder. As the information in Table 22 shows, CONUS and overseas personnel worked in both control tower and radar facilities, although a higher percentage of Air Traffic Control Specialists assigned overseas were assigned to Radar facilities. Therefore, it was not surprising that the review of the task information in Table 23 indicated the two groups differ primarily on the basis of Control Tower (CONUS) and Radar Control (overseas) tasks.

In an effort to get a clearer picture of differences between CONUS and overseas Control Tower Controllers and Radar Controllers, a more detailed analysis was conducted. This was accomplished by comparing the CONUS and overseas 5-skill level personnel in the Control Tower Personnel and Radar Air Traffic Control Personnel clusters. The results of these comparisons are presented in Tables 24 and 25. These Tables indicate the primary differences between CONUS and overseas groups were due to a few unique operating procedures. Overall CONUS and Overseas personnel perform the same basic job.

Combat Control Team - DAFSC 27250D

The survey population contained 33 personnel with a duty AFSC of 27250D. Of this group, 20 or 61 percent were assigned to CONUS locations. Table 26 lists those tasks which best distinguish between 27250D CONUS and Overseas personnel. Generally, slightly higher percentages of overseas personnel indicated they perform supervisory functions. On the other hand, higher percentages of 5-skill level CONUS personnel indicated they participate in various kinds of operations. Although the data show clearcut differences between the two groups, no significant trends were evident. It appears that differences were due more to unique Combat Control Team missions than to CONUS or overseas location.

TABLE 22

BACKGROUND INFORMATION FOR AIR TRAFFIC CONTROL AND COMBAT CONTROL TEAM
 CONUS-OVERSEAS COMPARISONS
 (PERCENT MEMBERS PERFORMING)

		27250	
		<u>CONUS</u>	<u>OVERSEAS</u>
<u>HOLD SPECIAL EXPERIENCE IDENTIFIER</u>			
053	GROUND CONTROL APPROACH	11	24
054	GROUND CONTROL APPROACH-RADAR FINAL	15	23
056	CONVENTIONAL CONTROL TOWER	35	36
364	ATC RADAR APPROACH CONTROL	35	45
<u>WORK AREA</u>			
	CONTROL TOWER FACILITY	46	38
	RADAR FACILITY	50	61
<u>DUTY TITLE</u>			
	AIR TRAFFIC CONTROLLER, RADAR	52	65
	AIR TRAFFIC CONTROLLER, TOWER	48	38
<u>TYPE OF FACILITY ASSIGNED TO</u>			
	GROUND CONTROL APPROACH (GCA)	8	15
	RADAR APPROACH CONTROL (FIXED)	37	34
	RADAR APPROACH CONTROL (MOBILE)	2	17
	VCM CONTROL TOWER (FIXED)	39	31

TABLE 23

TASKS BEST DIFFERENTIATING 27250 CONUS AND OVERSEAS PERSONNEL

TASKS	PERCENT PERFORMING	
	CONUS	OVERSEAS
UPDATE FLIGHT DATA ON FLIGHT DATA ENTRY PRINTOUT (FDEP)	45	3
PERFORM SECURITY CONTROL OF AIR TRAFFIC AND NAVIGATION AIDS (SCATANA) PROCEDURES	33	11
ADJUST BRITE II RADAR SYSTEMS	44	25
OPERATE ROTATING BEACONS	44	28
ISSUE OR TRANSMIT EN ROUTE CLEARANCE USING HOST NATION AGREEMENT PROCEDURES	2	27
MARK DECISION HEIGHT LINES ON RADAR INDICATORS	44	62
ACTIVATE BACKUP ELECTRICAL POWER SYSTEMS	24	42
OPERATIONALLY CHECK ANTENNA TILT METERS	7	25
CALCULATE LOWEST USEABLE FLIGHT LEVELS	13	30

TABLE 24

TASKS WHICH BEST DIFFERENTIATE 27250 CONUS AND OVERSEAS
CONTROL TOWER PERSONNEL

TASKS	PERCENT PERFORMING	
	CONUS	OVERSEAS
OPERATE AUTOMATIC TERMINAL INFORMATION SERVICE (ATIS)	63	26
PERFORM OPERATIONAL CHECKS ON ATIS	54	25
UPDATE FLIGHT DATA ON FLIGHT DATA ENTRY PRINTOUT (FDEP)	31	2
OPERATE ROTATING BEACONS	95	72
PERFORM SECURITY CONTROL OF AIR TRAFFIC AND AIR NAVIGATION AIDS (SCATANA)	45	23
OPERATE GENERATORS	18	52
ISSUE OR TRANSMIT EN ROUTE CLEARANCES USING HOST NATION AGREEMENT PROCEDURES	0	31
ACTIVATE BACKUP ELECTRICAL POWER SYSTEMS	27	52
ISSUE OR TRANSMIT EN ROUTE CLEARANCES USING INTERNATIONAL CIVIL AVIATION ORGANIZATION (ICAO) PROCEDURES	2	26
OPERATE NAVAID EQUIPMENT MONITORS	36	59

TABLE 25

TASKS WHICH BEST DIFFERENTIATE 27250 CONUS AND OVERSEAS
RADAR AIR TRAFFIC CONTROL PERSONNEL

TASKS	PERCENT PERFORMING	
	CONUS	OVERSEAS
UPDATE FLIGHT DATA ON FLIGHT DATA ENTRY PRINTOUT (FDEP)	56	1
PERFORM SECURITY CONTROL OF AIR TRAFFIC AND AIR NAVIGATION AIDS (SCATANA) PROCEDURES	49	18
ISSUE OR TRANSMIT ENROUTE CLEARANCES USING FAA PROCEDURES	69	39
REROUTE AIRCRAFT AROUND MILITARY OPERATIONAL AREAS	43	23
PROVIDE STAGE I, II, OR III RADAR SERVICES	79	63
ISSUE OR TRANSMIT EN ROUTE CLEARANCES USING INTERNATIONAL CIVIL AVIATION ORGANIZATION (ICAO) PROCEDURES	2	42
ISSUE OR TRANSMIT EN ROUTE CLEARANCE USING HOST NATION AGREEMENT PROCEDURES	1	37
OPERATE GENERATORS	21	57
ACTIVATE BACKUP ELECTRICAL POWER SYSTEMS	38	66
OPERATIONALLY CHECK RADAR ANTENNA TILT METERS	18	45
DIRECT AND VECTOR AIRCRAFT TO FUEL DUMPING AREAS	50	69

TABLE 26

TASKS BEST DIFFERENTIATING 27250D CONUS AND OVERSEAS PERSONNEL

TASKS	PERCENT PERFORMING	
	CONUS	OVERSEAS
PERFORM DESERT OPERATIONS	40	0
SEQUENCE DEPARTING AIRCRAFT	50	15
PERFORM JUNGLE OPERATIONS	50	15
SEQUENCE LANDING AIRCRAFT	55	23
PERFORM COMBAT CONTROL AMPHIBIOUS OPERATIONS	60	31
PERFORM RUNWAY CHECKS	75	46
DETERMINE WORK PRIORITIES	30	59
PERFORM CONVENTIONAL APPROACH CONTROL PROCEDURES	35	69
DIRECT DEVELOPMENT OR MAINTENANCE OF STATUS BOARDS, GRAPHS, OR CHARTS	5	38
NOTIFY AGENCIES OF RUNWAYS IN USE	5	38
ANNOTATE INDIVIDUAL JUMP RECORD FORMS (AF FORM 922)	30	62
EVALUATE WORKLOAD REQUIREMENTS	0	31

COMPARISON OF THE CURRENT SURVEY WITH THE PREVIOUS SURVEY

The Air Traffic Control specialty was last surveyed in the spring of 1976. At that time, the career ladder consisted of the following four shreds:

- A - Air Traffic Control Operator, Conventional Control Tower
- B - Air Traffic Control Operator, Ground Controlled Approach, Precision Approach Control
- C - Air Traffic Control Operator, Air Route Traffic Control Center (Manual), Air Route Traffic Control Center (Radar), Air Traffic Regulation Center
- D - Air Traffic Control Operator, Combat Control Team Operations

In October 1977, the A, B, and C shreds were deleted. This action altered the manner in which 272X0 personnel were utilized and the jobs they performed. Consequently, the previous 1976 inventory was updated and reorganized to more accurately reflect these changes. This entailed rearranging a large number of tasks to improve clarity. In addition, many obsolete tasks were deleted and other newer tasks were added.

Despite the deletion of the A, B, and C shreds and the corresponding changes to the 1980 Job Inventory, the findings of both studies were relatively consistent. Differences were observed, however, in the following areas:

(1) More distinct RAPCON Operator and entry level types of jobs were identified in the previous study. It appears this was due to the fact that RAPCON personnel previously specialized more on the basis of experience. Presently RAPCON personnel are more homogeneous in terms of the jobs they perform. The differences which currently exist are due more to the presence or absence of supervisory functions. In fact, two RAPCON supervisory groups (RAPCON Supervisors and RAPCON Chief Controllers) were identified in the current study which have no counterparts in the previous 1976 study.

(2) Distinct Radar/Air Route Control Center Controller and Center Controller job types were identified in the previous study. These did not break out in the current study. The closest any of the 1980 job groups came to either of these groups was the Radar Range Controllers.

(3) A new Technical School Instructor job has developed since the last survey. The previous study identified a large group of instructors and a smaller group of senior instructors who differed primarily on the basis of supervisory tasks. The current study identified two instructor jobs; however, they had little in common with each other. The Technical School Instructors IJT was very similar to the instructor group identified in the previous study in that they both devoted the majority of their time to classroom related tasks. The Radar Instructors job type differed in that they devoted the majority of their time to instructing Radar functions in a simulated environment. These personnel clearly specialized in the training of Radar functions.

(4) The job of Flight Facilities Superintendent which was identified in the previous study did not break out in the present study. On the other hand, the jobs of Terminal Instrument Procedures Specialists (TERPS) or Air Traffic Control Analysts and CCT Training and Standardization NCOs did not appear as distinct groups in the 1976 study.

(5) Finally, a thorough analysis of the job interest and perceived utilization of talents and training for the major cluster groups in the 1976 and 1980 studies show only minor shifts (see Table 27). Overall job satisfaction for the 272X0/D career ladder has declined slightly in these areas.

In terms of reenlistment intent (Table 27), only six percent more of the Control Tower and Radar Air Traffic Control personnel indicated they did not plan to reenlist when compared to the 1976 sample. However, a surprisingly high percentage of 272X0D personnel indicated they would not or were uncertain about reenlisting (40 percent versus 11 percent in the 1976 study).

TABLE 27

EXPRESSION OF JOB SATISFACTION FOR 1976 AND 1980 272X0 GROUPS
(PERCENT MEMBERS RESPONDING)

	272X0 TOTAL SAMPLE		CONTROL TOWER		RADAR ATC		272X0D TOTAL SAMPLE	
	1976 (N=1,814)	1980 (N=2,039)	1976 (N=567)	1980 (N=662)	1976 (N=758)	1980 (N=883)	1976 (N=54)	1980 (N=77)
<u>I FIND MY JOB:</u>								
DULL	4	7	3	7	5	5	5	5
SO-SO	5	7	2	7	3	6	-	7
INTERESTING	91	83	95	83	92	86	95	87
NO REPLY	-	3	-	3	-	3	-	1
<u>MY JOB UTILIZES MY TALENTS:</u>								
VERY LITTLE	12	14	9	15	9	12	9	11
FAIRLY WELL OR BETTER	88	84	91	83	91	87	91	87
NO REPLY	-	2	-	2	-	1	-	2
<u>MY JOB UTILIZES MY TRAINING:</u>								
VERY LITTLE	6	11	6	9	7	9	9	14
FAIRLY WELL OR BETTER	94	88	94	89	93	90	91	85
NO REPLY	-	1	-	2	-	1	-	1
<u>I PLAN TO REENLIST:</u>								
NO, OR PROBABLY NO	51	48	43	49	45	51	11	35
YES, OR PROBABLY YES	49	50	55	49	53	48	88	65
NO REPLY	-	2	2	2	2	1	1	-

ANALYSIS OF WRITE-IN COMMENTS

Respondents were invited to write in any comments relative to their job on a blank page provided at the back of the job inventory booklet. In this survey, three general areas of concern were addressed by many of the write-in comments. These include: 1) concern about pay and advancement; 2) the effect of ATC regulations or local procedures on morale; and 3) dissatisfaction due to perceived misutilization of talents.

Concern About Pay and Advancement

Overall, morale is very good across the board for 272X0/D personnel. However, as one individual stated, "to be good, Air Traffic Controllers have to see themselves as a cut above any other AFSC." In personal conversations with 272X0 personnel, it appears that many, if not the majority, do perceive themselves in this light. Consequently, it is not surprising that many write-in comments are directed at inadequate pay and promotions. A typical comment is presented below:

"I would like to say that I think the amount of pressure and responsibility that is put on a controller at some bases like this one is not worthy of our current pay structure. I really feel that we are deserving of some propay or at least make it a little more easy to pass the SKF." (E-4 Tower Controller)

With regard to promotions, most of the complaints came from tower controllers with no RAMPON experience. Most Tower Control Personnel are either not allowed to, or are unable to certify in a radar related air traffic control function until their second or subsequent enlistments. Many perceive this as hurting their chances for promotion when taking the Specialty Knowledge Test (SKT).

The Effect of ATC Regulations or Local Procedures on Morale

Although, as previously mentioned, overall morale is quite good, many Air Traffic Controllers feel overregulated and chafe under many of the regulations imposed upon them. The following write-in comment from a Control Tower Supervisor summarizes many of these complaints:

"After nearly 26 years as an Air Traffic Controller, it still remains very interesting and challenging. However, the field could be much improved by drastic, innovative decisions made by staff planners. Here are some suggestions:

(1) Get off people's backs. Everybody acts as if it's a mortal sin to screw up. (of course, we try to eliminate mistakes but there's only one person I've heard of that never screws up). Consequently, supervisors are becoming extremely afraid to make decisions--any decisions--unless they can quote a direct reference to the rule. They are no longer trusted.

(2) Get rid of paperwork. Probably 75 percent of AF's paperwork could be eliminated, and never be missed. (Case in point: AF Form 1134, Position Log. Are these really necessary? In RAPCON, possibly, but in a tower where you have two controllers?).

(3) Give more than lip-service to the AF's people-oriented policies. Many of these look good on paper (and to the originator's boss) but are completely unworkable in actual situations.

(4) Let supervisor's do their job. Some officers require them to contact them with every little item. None of us will deliberately screw up, believe me!

(5) Have less, not more, documentation of training. The vast majority of trainees get rated in adequate time. Daily or weekly reports are completely unnecessary, except for those identified as having problems. Use monthly proficiency tests for facility training, not training for an SKT exam. (And some TSS's confuse quantity with quality on the test questions.)

(6) Get rid of so many inspections; i.e., pre-IG, IG, post-IG; pre-ATC analysis, ATC analysis, post-ATC analysis; Ops Evals; etc. They seem to be never-ending and are, except for writing in pencil in 623 where it should be in ink, VERY unnecessary. Can an inspection team come thousands of miles and tell me (or others) what's wrong with the facility? They can, but not anything we don't know. Give us the necessary authority to get something done.

(7) Have realistic manning/work schedules. In most towers, one controller on mids is one too many. What is two controllers? Get rid of 1, 3, 5, 7, 9 levels. You're either qualified or not. Let the people in the field decide who works as what. Many times, a very weak (undeserving) 7-skill level is listed as crew chief ahead of another more deserving of it based only on experience. Experience should be a factor, yes, but skill level is much more important." (E-5, Control Tower Supervisor)

Another comment which illustrates some of the frustrations which result from conflicting local procedures is presented below:

"I feel ATC is extremely interesting. But my job here is very dull due to local procedures that will not allow the controllers, or supervisors to be controllers. Every thing we do, right or wrong must be explained if a SAC A/C does not get just what he wants (i.e., told to extend down-wind to follow a transient A/C etc). He calls command post, and they call the tower and tell us to have the transient A/C land or depart the area because he is interfering with SAC training. This is done without the command post knowing if the transient is a full stop or not. The command post has more control on who will land or go around than the controllers do." (E-7, Control Tower Watch Supervisor)

Obviously, any function as critical as Air Traffic Control must be strictly controlled to insure high standards. The majority of the Air Traffic Controllers are willing to accept these regulations as an important and necessary part of the job. However, it is the unnecessary paperwork or conflicting local regulations which appear to be most irritating.

Dissatisfaction Due to Perceived Misutilization of Talents

Many of the more frustrated 272X0/D personnel perceive their present job does not utilize their experience well. Most personnel who feel under-utilized in their present positions think individuals should be more carefully screened for positions. The following comment summarizes this point of view:

"Should check manning & records of each individual; evaluate ratings, and use the experience that's in the field more effectively than we are now (presently). Some are stuck where they do little good, if none at all." (E-6, PAR Controller)

As previously mentioned in the career ladder structure analysis, the Mobile Air Traffic Control Personnel (GRP108) are clearly the most dissatisfied of all the 272X0/D job groups identified. Many of the personnel in this independent job group are assigned to the Fifth Combat Communications Group. These personnel are dissatisfied because of the perception that they have no job to perform and are concerned that they are losing proficiency. The following comments summarize their concern:

"Presently, I am a 27250 tower controller. Due to the nature of our mission, the actual duty of controlling traffic is nonexistent unless we're tasked for an exercise. Myself, I have not controlled an aircraft in eight months." (E-5, Mobile Air Traffic Controller)

"My Air Traffic Control ability and proficiency is at a standstill, very little time is spent on the job-only when TDY." (E-5, Mobile Air Traffic Controller)

"As an Air Traffic Controller assigned to the 5th Combat Communications Group, I've realized a loss of proficiency and confidence due to the lack of position time and traffic. I only work actual traffic when TDY on an exercise and, more times than not, the traffic I work when TDY is not sufficient to bring up proficiency lost during inactivity while in station. I'm at a standstill." (E-5, Mobile Air Traffic Controller)

Due to the unique mission of the combat communications group, there may be no solution to the problem. However, it is obvious from overall morale and the write-in comments that these personnel want to do more than they are currently allowed to do.

Finally, although overall Combat Control Team (CCT) morale is much better than that of the Mobile Air Traffic Controller, many CCT personnel are dissatisfied with their training. This concern is summarized well in the following write-in comment:

"In all areas of continuation training and proficiency training, we spend too much time TDY supporting wing training to maintain a real combat ready status. Too much of our team training is just eyewash to fill the squares that can't be maintained throughout the year. Even with semiannual dedicated training weeks, there is no way to accomplish all of the required training in a realistic or even productive manner. Therefore it is unrealistic to think of CCT as an effective combat ready unit without more time and support to accomplish our own training." (E-5, Combat Control Team Member)

IMPLICATIONS

The consolidation of the 272X0A, B, and C shreds has resulted in a relatively stable dual function job structure. Although both Control Tower and Radar Air Traffic Control personnel perform many general Air Traffic Control functions in common, they still specialize in distinctly different technical areas. Currently all 272X0 personnel are trained to perform both jobs. Personnel are then assigned to either a tower or radar function upon their arrival at their initial duty assignment. Most continue to perform in their assigned tower or radar capacity during this initial assignment and throughout their first enlistment. Generally, by the second or third enlistment, 272X0 personnel become certified in both tower and radar approach control. However, a small percentage are never certified in any area other than control tower.

In view of this, some form of channelized training for tower and radar control personnel is worthy of consideration. This channelized approach could consist of an initial phase designed to teach those tasks performed in common by both radar and control tower personnel, and separate follow-on courses for radar and control tower personnel. This approach would have the advantage of being more cost effective. However, the major drawback would be the limitations it would impose in terms of assignment flexibility.

Presently MAC and AFCC command representatives are in agreement that the 272X0D shred should be eliminated and a new AFSC created for Combat Control Team personnel. The occupational survey data indicate these personnel perform distinctly different functions in relation to Air Traffic Control personnel. This conclusion is based on the analysis of the career ladder structure. The three major 272X0 clusters (Control Tower Personnel, Radar Air Traffic Control Personnel, and Air Traffic Control Supervisors) are more homogeneous in relation to each other in terms of a large body of General Air Traffic Control tasks common to all three. However, in terms of tasks performed and relative time spent performing those tasks, Combat Control Team Personnel have little in common with any of the other three clusters. In view of the distinctly different job Combat Control Team Personnel perform, it must be concluded that this is a distinct function worthy of its own AFSC designation. Barring this, training should be tailored for these personnel by eliminating many of the Air Traffic Control tasks they are trained to perform which are not a part of the Combat Control Team job.

APPENDIX A
JOB TYPE AND SUBJOB TYPE DESCRIPTIONS

Job Type Descriptions

Listed below are brief descriptions of the job types identified within the clusters described in the career ladder structure analysis. Overall, the job types within a given cluster are fairly similar. However, there are differences which result from experience, types or equipment operated or a combination of both. Generally, Control Tower and Combat Control Team job types reflect differences more on the basis of experience, whereas Radar Air Traffic Control job types tend to break out more on the basis of equipment operated. For additional information, the Tables at the end of this Appendix list various duty, background and job satisfaction data for all of the job types identified. (For descriptions of the clusters and independent job types, see the Career Ladder Structure section of this report.)

I. CONTROL TOWER PERSONNEL CLUSTER. Four job types were identified within this cluster: Tower Trainer-Supervisors, Tower Controllers, Junior Tower Controllers, and Tower Watch Supervisors. Brief descriptions of each job type are presented below. For additional information, reference Tables A-1 and A-2 at the rear of this Appendix.

Ia. Tower Trainer-Supervisors Job Type (GRP472). These personnel are experienced Control Tower Operators who also perform numerous training functions and some supervisory tasks. Due to this broad range of tasks, these personnel perform a higher average number of tasks than any other job type within the Control Tower Personnel cluster. Listed below are examples of tasks this group performs which differentiate it from other job types within the cluster.

- Maintain training records, charts, or graphs
- Supervise Air Traffic Control Operators (AFSC 27250)
- Perform On-the-Job performance evaluations of Air Traffic Controllers
- Evaluate OJT trainees
- Counsel trainees on training progress
- Conduct control tower proficiency training
- Assign personnel to duty positions
- Supervise Apprentice Air Traffic Control Operators (AFSC 27230)

Ib. Tower Controllers Job Type (GRP445). This, the largest job type within the Control Tower Personnel cluster, accounts for 52 percent of the individuals in the cluster. With the exception of training and supervision tasks, these personnel perform the same control tower functions as Tower Trainer-Supervisors (GRP 472). The majority are 5-skill level personnel in their first or second enlistment. Typical tasks performed do not differ significantly from those listed for the Control Tower Personnel cluster (GRP 160).

Ic. Junior Tower Controllers Job Type (GRP218). These personnel perform a limited range of less difficult control tower functions. Forty percent indicate they had not yet certified in Control Tower Operations while the remainder were primarily recently certified tower controllers. Most indicated they were in their first enlistment and had less than 12 months on their present job. They perform the same kinds or tasks as Tower Controllers

with the exception of some more difficult tasks. Examples of more difficult tasks which are not commonly performed by these personnel but which are performed by both Tower Controllers (GRP 445) and Tower Trainer-Supervisors (GRP 472) include:

- Check field operating conditions
- Initiate antihijacking procedures
- Initiate emergency assistance procedures
- Authorize visual separations
- Monitor voice communications
- Perform simulated crash, alert, or disaster control exercises
- Assign frequencies to aircraft
- Conduct briefings on ATC operation equipment

Id. Tower Watch Supervisors Job Type (GRP186). These individuals devote less time to general Air Traffic Control and Tower Control functions and more time to training and supervision tasks. However, the majority of their time (60 percent) is still devoted to nonsupervisory functions. These worker-supervisors are primarily 7-skill level personnel. Examples of tasks which differentiate this group from the other job types within the Control Tower Personnel cluster include:

- Conduct control tower proficiency training
- Conduct facility rating training
- Assign personnel to duty positions
- Supervise Air Traffic Control Operators (AFSC 27250)
- Direct procedures for performing equipment checks
- Direct or implement OJT programs
- Evaluate individuals for promotions, demotions, or reclassifications
- Administer tests

II. RADAR AIR TRAFFIC CONTROL PERSONNEL CLUSTER. The Radar Air Traffic Control Personnel cluster consists of seven distinct job types. These are PAR or GCA Controllers, Dual Certified Controllers, RAPCON Controllers, GCA or GRFC Trainer-Supervisors, RAPCON Technician-Supervisors, Radar Range Controllers, and Radar Instructors. In addition, subjob types break out within the PAR or GCA Controllers job type (GCA or GRFC Personnel, RAPCON PAR or Arrival Personnel, Limited Duty RAPCON PAR or Arrival Personnel, and GRFC or GCA Senior Controllers); the Dual Certified Controllers job type (PAR or GCA and Tower Controllers, Standardization and Evaluation NCOs, Dual Rated First Line Supervisors, and RAPCON and Tower Controllers); and the RAPCON Controllers job type (RAPCON Operators and RAPCON First Line Supervisors). For additional information reference Tables A-3 through A-8 at the rear of this appendix.

Iia. PAR or GCA Controllers Job Type (GRP263). These individuals perform a narrower range of tasks than RAPCON personnel. They are generally 5-skill level (66 percent), first enlistment personnel (60 percent) who specialize in precision radar approaches. Interestingly 39 percent indicate they are assigned at overseas installations. These personnel devote a major portion of their relative time to the following kinds of tasks:

- Provide precision radar approaches
- Issue missed approach instructions
- Provide radar surveillance approaches
- Issue decision height altitude advisories
- Issue minimum descent altitude advisories
- Operationally check radar displays of touchdown and bracketing reflectors
- Mark decision height lines on radar indicators
- Identify aircraft using transponder methods
- Provide radar monitoring of instrument approaches

Four subjob types were identified within the PAR/GCA Controller (GRP263) job type. These are:

- GCA or GRFC Personnel (GRP546)
- RAPCON PAR or Arrival Personnel (GRP535)
- Limited Duty RAPCON PAR or Arrival Personnel (GRP383)
- GRFC or GCA Senior Controllers (GRP313)

All four subjob types perform the tasks listed under PAR or GCA Controller (GRP263) in common. However, they specialize in other groups of tasks which tend to differentiate them from other subjob types.

Ila(1) GCA or GRFC Personnel Subjob Type (GRP546). These personnel perform few IFR related tasks and they operate no NAVAID equipment monitors. Consequently, the range of tasks they perform is very limited. They perform the kinds of tasks listed under the PAR or GCA Controllers job type (GRP 263). In addition to these, they devote more time to the following kinds of tasks:

- Remove or replace teleautewriter paper
- Operationally check radar antenna tilt meters
- Report radar malfunctions
- Update events log forms (AF Form 1924)
- Prepare position log forms (AF Form 1134)

Ila(2) RAPCON PAR or Arrival Personnel Subjob Type (GRP535). These personnel perform a narrow range of primarily RAPCON radar final control tasks which differentiates them from the other subjob types. However, these final control tasks are performed in addition to the body of PAR or GCA tasks which all the subjob types perform in common. (See Ila. PAR or GCA Controller job type). Examples of these differentiating final control tasks include:

- Issue IFR holding instructions
- Authorize IFR aircraft departures
- Formulate IFR clearances
- Provide Stage I, II, or III radar services
- Relay IFR clearances
- Operate NAVAID equipment
- Relay aircraft arrival or departure times
- Monitor aircraft departures on radar

IIa(3) Limited Duty RAPCON PAR or Arrival Personnel Subjob Type (GRP383). These are primarily 3- and 5-skill level first enlistment RAPCON personnel with less than a year on their present job. They perform many of the same kinds of functions as RAPCON PAR or Arrival Personnel (GRP 535). However, there are some tasks which a higher percentage of the former group performs. These tasks include:

- Coordinate aircraft handoffs
- Issue advance approach information to arriving aircraft
- Inform aircrew of radar identification status
- Establish approach sequences
- Provide Stage I, II, or III radar services
- Provide radar advisories to VFR aircraft
- Authorize IFR aircraft departures
- Inform aircrew of radar terminations

IIa(4) GRFC or GCA Senior Controllers Subjob Type (GRP313). These individuals are more senior personnel in a worker-supervisor capacity at precision approach radar facilities. Most hold the 7-skill level and are in their third enlistment. Slightly more (52 percent) indicate they are assigned to GRFC rather than GCA facilities. Examples of tasks which differentiate them from the other subjob types previously identified include:

- Supervise Air Traffic Control Operators, AFSC 77250
- Assign personnel to duty positions
- Prepare APRs
- Approve or disapprove power transfers
- Direct precision approach radar activities
- Conduct GCA proficiency training
- Maintain training records, charts, or graphs
- Update events log forms (AF Form 1924)

IIb. Dual Certified Controllers Job Type (GRP326). This group is unique in that group members devote roughly equal amounts of time to performing both Radar and Tower Control functions. It is a rather diverse group consisting of 5- and 7- skill level personnel, most of whom are in their third or fourth enlistment. Representative tasks include:

- Maintain surveillance of airport movement and traffic areas
- Sequence landing aircraft
- Approve or disapprove takeoffs
- Provide precision radar approaches
- Control and separate aircraft using precision approach radar
- Issue decision height altitude advisories
- Issue missed approach instructions
- Assign runways for landings or takeoffs

Four different jobs or subjob types were identified within the Dual Certified Controllers job type (GRP 326). Although they all perform the tasks listed above in common, they tend to specialize in different areas. This specialization makes each job unique in comparison to the others. These four subjob types which will be discussed in more detail later include:

PAR or GCA and Tower Controllers (GRP 480)
Standardization and Evaluation NCOs (GRP 1139)
Dual Rated First Line Supervisors (GRP 895)
RAPCON and Tower Controllers (GRP 744)

Iib(1) PAR or GCA and Tower Controllers Subjob Type (GRP480). These are dual rated personnel who perform the same kinds of tasks as PAR or GCA Personnel (GRP 546) and Tower Controllers (GRP 445). Most indicate they are certified in the areas of Control Tower (86 percent), GCA Radar Final Control (47 percent) and Radar Final Control (41 percent). Typical tasks performed do not vary significantly from those listed under the Dual Certified Controllers job type (GRP 326).

Iib(2). Standardization and Evaluation NCOs Subjob Type (GRP1139). These NCOs appear to perform a combination of three separate jobs: RAPCON Control, Tower Control, and Standardization and Evaluation. Consequently, they perform a very high average number of tasks (184). Those tasks which most clearly distinguish them from the other subjob types are listed below:

- Administer facility rating examinations
- Score tests
- Update facility rating suspense files
- Issue IFR holding instructions
- Write general correspondence
- Prepare and submit recommendations for improving and standardizing Air Traffic Control procedures
- Evaluate ATC methods or techniques
- Authorize nonapproach control tower to provide visual separation between arrivals and departures
- Perform airborne radar beacon checks

Iib(3) Dual Rated First Line Supervisors Subjob Type (GRP895). Like the Standardization and Evaluation NCOs (GRP1139), the members of this group perform a combination of three different jobs - RAPCON Control, Tower Control, and First Line Supervision. The scope of their job is so broad that they perform a higher average number of tasks (197) than any other job group identified. The kinds of tasks which tend to differentiate them from other dual certified controller subjob types include:

- Maintain NAVAID status charts
- Demonstrate how to locate technical information
- Prepare traffic count forms
- Direct precision approach radar activities
- Prepare APRs
- Update OJT records
- Direct visual meteorological conditions (VMC) control tower activities
- Conduct facility rating training
- Maintain training records, charts, or graphs
- Counsel trainees on training progress

Iib(4) RAPCON and Tower Controllers Subjob Type (GRP744). These dual rated personnel perform a combination of two jobs - RAPCON Control and Tower Control. The two jobs which most closely resemble the scope of tasks performed are RAPCON Controller (GRP 619) and Tower Controller (GRP 445). Although most supervise both 3- (68 percent) and 5-skill level personnel (56 percent), they function more as technicians than managers. They perform most of the same kinds of tasks as PAR or GCA and Tower Controllers (GRP 480); however, higher percentages of this group perform RAPCON related functions. Examples of these RAPCON functions include:

- Provide radar advisories to VFR aircraft
- Monitor aircraft departures on radar
- Establish approach sequences
- Issue advance approach information to arriving aircraft
- Provide Stage I, II, or III radar services
- Issue alternate clearances

Iic. Radar Approach Control (RAPCON) Controllers Job Type (GRP488). These airmen perform a wide range of radar air traffic control tasks. Two subjob types (RAPCON Operators and RAPCON First-Line Supervisors) combine to form this, the largest of the job types identified within the Radar Air Traffic Control Operators cluster. The two subjob types perform basically the same job, however, the RAPCON First Line Supervisor performs some additional supervisory tasks. Examples of these include:

- Identify aircraft using transponder methods
- Perform radar handoffs
- Assign transponder modes and codes
- Provide Stage I, II, or III radar services
- Monitor aircraft departures on radar
- Issue advance approach information to arriving aircraft
- Provide precision radar approaches
- Authorize instrument flight rules (IFR) aircraft departures

Iic(1). RAPCON Operators Subjob Type (GRP619). These personnel perform the whole range of radar approach control functions including approach, arrival, precision final, and departure control. Minor variations among these personnel result due to experience, size of facility, local mission, or a combination of the three. However, these differences are not significant. These personnel perform the same kinds of tasks as are listed under the Radar Approach Control (RAPCON) Controllers job type (GRP 488).

Iic(2) RAPCON First Line Supervisor Subjob Type (GRP622). These personnel perform the same range of tasks as the RAPCON Specialist (GRP 724). However they perform a body of more difficult technical and supervisory functions. Consequently, they perform an average of 40 more tasks than the RAPCON Specialist. Their job titles include Air Traffic Controller (ATC); ATC Specialist; ATC Technician; ATC Operator; Watch Supervisory; Crew Chief; and Assistant Chief Controller, RAPCON Section. Some of the kinds of supervisory tasks which differentiate these personnel from RAPCON Operators include:

- Supervise Air Traffic Control Operators (AFSC 27250)
- Conduct RAPCON proficiency training
- Evaluate OJT trainees
- Counsel personnel on personal or military related problems
- Prepare APRs
- Assign personnel to duty positions
- Direct RAPCON activities
- Perform OJT performance evaluations of Air Traffic Controllers

IId. GCA or GRFC Trainer-Supervisors Job Type (GRP573). These personnel differ from the GRFC or GCA Senior Controllers (GRP 313) in that they perform a wider range of technical tasks, more training related tasks, and fewer direct supervision tasks. In terms of organizational structure, experience, and tasks performed they interface between the GRFC or GCA Senior Controllers (GRP 313) and the GCA or GRFC personnel (GRP 546). Examples of tasks unique to this group include:

- Maintain training records, charts, or graphs
- Perform On-the-Job performance evaluations of Air Traffic Controllers
- Evaluate OJT trainees
- Counsel trainees on training progress
- Conduct GCA proficiency training
- Update OJT records
- Operate radar simulators

IHe. RAPCON Technician-Supervisors Job Type (GRP273). These personnel are similar to the RAPCON First Line Supervisors (GRP622) in that they devote the majority of their time to radar and general air traffic control functions. However, the RAPCON Technician-Supervisor devote slightly more time to organizing and planning, directing and implementing, and training related functions. Examples of tasks which higher percentages of RAPCON technician-supervisors perform include:

- Evaluate training methods or techniques
- Assign OJT trainers
- Determine work priorities
- Administer tests
- Assign personnel to duty positions
- Administer facility rating

IIf. Radar Range Controllers Job Type (GRP300). These personnel monitor range areas at Nellis, Eglin, Holloman, and other installations. Due to the nature of their work, they perform some functions which are usually performed by air traffic control centers. These area control functions are what differentiate this group from other job types within the Radar Air Traffic Control Operators cluster. Examples of unique or differentiating tasks include:

- Authorize aircraft operations in warning or restricted areas
- Calculate lowest useable flight levels
- Approve aerial refueling operations
- Calculate enroute aircraft position estimates

IIg. Radar Instructors (GRP244). These personnel devote the majority of their time to hands-on training in a radar laboratory setting. They are Air Training Command instructors at Keesler who conduct a separate block of radar training. Examples of typical tasks include:

- Operate radar simulators
- Monitor aircraft departures on radar
- Provide precision radar approaches
- Identify aircraft using primary radar and transponder methods
- Provide radar surveillance approaches
- Counsel trainees on training progress
- Prepare lesson plans
- Administer tests

III. AIR TRAFFIC CONTROL SUPERVISORS CLUSTER. Five job types were identified within this cluster: Tower Supervisors, RAPCON Supervisors, Training and Standardization NCOs, Chief Controllers, and RAPCON Chief Controllers. For additional information reference Tables A-9 and A-10 in Appendix A.

IIIa. Tower Supervisors Job Type (GRP381). These personnel divide their time equally between supervisory and various control tower, air traffic control and other related functions. They are clearly high level supervisors as 90 percent indicate they supervise 7-skill level personnel. They report a variety of job titles including Chief Controller, Watch Supervisor, Crew Chief, Assistant Chief Controller, Deputy Chief Controller, Air Traffic Control Technician, and Training and Standardization Specialist. The following is a listing of representative tasks these personnel perform:

- Direct visual meteorological conditions (VMC) control tower activities
- Interpret policies, directives, or procedures for subordinates
- Maintain surveillance of airport movement and traffic areas
- Write general correspondence
- Prepare APRs
- Supervise Air Traffic Control Technicians (AFSC 27270)
- Evaluate ATC methods or techniques
- Monitor facility rating training

IIIb. RAPCON Supervisors Job Type (GRP639). Like the Tower Supervisors (GRP 381), these personnel divide their time equally between technical and supervisory functions. They differ in that the RAPCON supervisors devote almost no time to tower functions and vice versa. The RAPCON Supervisors are primarily 7-skill level personnel who report the same range of duty titles as do the Tower Supervisors. The majority indicate they are assigned to RAPCON facilities (83 percent); however, 13 percent state they are assigned to GCA facilities. Examples of typical tasks include:

- Supervise AFSC 27250 and 27270 personnel
- Direct Radar Approach Control (RAPCON) activities
- Interpret policies, directives, or procedures for subordinates
- Prepare APRs
- Counsel trainees on training progress
- Supervise AFSC 27230 personnel
- Perform OJT performance evaluations of Air Traffic Controllers
- Counsel personnel on personal or military related problems

IIIc. Training and Standardization NCOs Job Type (GRP236). These NCOs are responsible for insuring personnel are properly trained, that they meet the required standards, and that problem areas are corrected. They generally occupy one-deep positions and do not supervise others. However, they do perform many supervisory tasks in the performance of their jobs. Typical functions include:

- Administer facility rating examinations
- Administer tests
- Prepare facility training guides
- Perform OJT performance evaluations of air traffic controllers
- Monitor facility rating training
- Evaluate ATC methods or techniques
- Evaluate compliance with performance standards

IIIId. Chief Controllers Job Type (GRP279). These senior NCOs are clearly supervisors, devoting approximately 90 percent of their total relative time to supervisory or training functions. The majority are Chief Controllers at VMC Control Tower facilities (55 percent) or other nonRAPCON facilities. In addition, the majority hold the 9-skill level (46 percent) or the CEM code 27200 (27 percent). Examples of typical tasks include:

- Interpret policies, directives, or procedures for subordinates
- Supervise Air Traffic Control Technicians (AFSC 27270)
- Evaluate ATC problem areas
- Write general correspondence
- Prepare and evaluate facility memoranda
- Counsel personnel on personal or military related problems
- Evaluate ATC methods or techniques
- Prepare APRs

IIIe. RAPCON Chief Controllers Job Type (GRP294). These supervisory personnel perform basically the same job as the Chief Controller (GRP 294). However, unlike the Chief Controllers, the majority of these individuals are assigned at RAPCON (67 percent), GCA (20 percent), or GRFC (13 percent) facilities. Consequently, they devote 35 percent of their total relative time to radar control and other related technical air traffic control functions. Examples of these technical tasks which are performed in addition to the tasks listed under the Chief Controller group include:

- Issue missed approach instructions
- Issue decision height altitude advisories
- Control and separate arriving aircraft using PAR
- Coordinate aircraft handoffs
- Identify aircraft using primary radar and transponder methods
- Provide PAR and radar surveillance approaches
- Monitor aircraft departures on radar
- Provide Stage I, II, or III radar services

VI. COMBAT CONTROL TEAM (CCT) PERSONNEL CLUSTER. Three job types were identified within this cluster: CCT Training and Standardization NCOs, Senior CCT Members, and CCT Members. For more background information, refer to Tables A-9 and A-10 in Appendix A.

Via. Combat Control Team Training and Standardization NCOs Job Type (GRP327). Although none of these personnel report a Training and Standardization job title, they clearly perform this function in addition to their primary job of Combat Control Team member. They are primarily 5- and 7-skill level personnel who average eight years in the D-shred. Examples of distinguishing tasks include:

- Prepare training schedules
- Write training reports
- Establish organizational policies, office instructions (OI), or Standard Operating Procedures (SOP)
- Write, administer, and score tests
- Evaluate training methods or techniques
- Prepare standardization check forms
- Direct or implement OJT programs
- Coordinate combat control training areas

Vib. Senior Combat Control Team Members Job Type (GRP324). These personnel are very similar to the Training and Standardization NCOs (GRP 327) in terms of background, experience, and the kinds of jobs they perform. The principle difference between the two is Senior Combat Control Team Members do not perform training and standardization functions. Examples of tasks which are representative of both job types include:

- Determine assault zone locations
- Write general correspondence
- Counsel personnel on personal or military related problems
- Supervise Combat Control Team Operators (AFSC 27250D)
- Prepare assault zone assessment forms (MAC Form 168)
- Configure support equipment for administration operations
- Operate site survey equipment
- Issue taxiing instructions

Vic. Combat Control Team Members Job Type (GRP154). These personnel devote the majority of their time to nonsupervisory combat control functions. Most of the combat control tasks they perform are also performed by Combat Control Team Training and Standardization NCOs (GRP327) and Senior Combat Control Team Members (GRP324). Examples of these tasks include:

- Pack parachutes
- Operate portable communication equipment
- Inspect parachutes
- Perform Combat Control Team demolition operations
- Perform static line operations
- Mark assault zones
- Clean work areas or equipment
- Operate portable NAVAID equipment

TABLE A-1

BACKGROUND INFORMATION FOR JOB TYPES WITHIN THE CONTROL TOWER CLUSTER

	CONTROL TOWER CLUSTER (GRP160)		TOWER TNG/SUP PERS (GRP472)		TOWER CONTROLLERS JOB TYPE (GRP445)		JUNIOR/CONTROLLERS JOB TYPE (GRP218)		TOWER WATCH SUPERVISORS JOB TYPE (GRP186)	
	NUMBER IN GROUP	AVERAGE NUMBER OF TASKS PERFORMED	AVERAGE PAYGRADE GROUP	DAFSC	PERCENT	PERCENT	PERCENT	PERCENT	PERCENT	PERCENT
NUMBER IN GROUP	662	180	345	47	15					
AVERAGE NUMBER OF TASKS PERFORMED	93	123	84	50	113					
AVERAGE PAYGRADE GROUP	4.5	5.2	4.1	3.9	6.3					
DAFSC										
27230	10%	2%	11%	43%	0					
27250	55%	32%	74%	40%	0					
27270	35%	66%	15%	17%	93%					
27299	0	0	0	0	0					
27200	0	0	0	0	0					
OTHER	0	0	0	0	7					
AVERAGE MONTHS IN CAREER FIELD	64	93	45	41	143					
AVERAGE MONTHS TAFMS	89	124	62	67	207					
PERCENT IN FIRST ENLISTMENT	38%	17%	52%	51%	0					
PERCENT ASSIGNED OVERSEAS	21%	28%	15%	13%	7%					
PERCENT WHO SUPERVISE OTHER	34%	62%	18%	11%	87%					

TABLE A-2

JOB INTEREST AND RELATED DATA FOR JOB TYPES WITHIN THE CONTROL TOWER CLUSTER
(PERCENT MEMBERS RESPONDING)

	(GRP160)	(GRP472)	(GRP445)	(GRP218)	(GRP186)
<u>I FIND MY JOB:</u>					
DULL	7	7	7	4	7
SO-SO	7	4	8	4	13
INTERESTING	83	87	82	87	80
NO RESPONSE	3	2	3	5	0
<u>MY JOB UTILIZES MY TALENTS:</u>					
NOT AT ALL TO VERY LITTLE	15	13	14	17	13
FAIRLY WELL TO PERFECTLY	83	86	84	79	80
NO RESPONSE	2	1	2	4	7
<u>MY JOB UTILIZES MY TRAINING:</u>					
NOT AT ALL TO VERY LITTLE	9	8	7	11	13
FAIRLY WELL TO PERFECTLY	89	91	91	87	80
NO RESPONSE	2	1	2	2	7
<u>I PLAN TO REENLIST:</u>					
NO OR PROBABLY NO	49	39	54	47	53
YES OR PROBABLY YES	49	58	45	51	46
NO RESPONSE	2	3	1	2	1

TABLE A-3

BACKGROUND INFORMATION FOR SUBJOB TYPES WITHIN THE PAR/GCA CONTROLLER JOB TYPE

	PAR/GCA CONTROLLER JOB TYPE (GRP263)	GCA/GRFC PERSONNEL SUBJOB TYPE (GRP546)	RAPCON		LTD DUTY		CRFC/GCA SENIOR CONTROLLERS SUBJOB TYPE (GRP313)
			PAR/ ARRIVAL PERSONNEL SUBJOB TYPE (GRP535)	PAR/ ARRIVAL PERSONNEL SUBJOB TYPE (GRP383)	PAR/ ARRIVAL PERSONNEL SUBJOB TYPE (GRP535)	PAR/ ARRIVAL PERSONNEL SUBJOB TYPE (GRP383)	
NUMBER IN GROUP	124	45	20	11		21	
AVERAGE NUMBER OF TASKS PERFORMED	70	68	80	58		82	
AVERAGE PAYGRADE GROUP	4.4	4.1	4.2	3.9		5.3	
DAFSC							
27230	10%	11%	15%	27%		0	
27250	66%	80%	65%	73%		24%	
27270	23%	9%	20%	0%		76%	
27299	0	0	0	0		0	
27200	0	0	0	0		0	
OTHER	1%	0	0	0		0	
AVERAGE MONTHS IN CAREER FIELD	56	41	57	37		102	
AVERAGE MONTHS TAFMS	76	58	70	47		135	
PERCENT IN FIRST ENLISTMENT	40%	53%	45%	55%		5%	
PERCENT ASSIGNED OVERSEAS	39%	29%	30%	36%		38%	
PERCENT WHO SUPERVISE OTHERS	25%	13%	30%	0		67%	

TABLE A-4
 JOB INTEREST AND RELATED DATA FOR SUB JOB TYPES WITHIN THE PAR/GCA CONTROLLER JOB TYPE
 (PERCENT MEMBERS RESPONDING)

	(GRP263)	(GRP546)	(GRP535)	(GRP383)	(GRP313)
<u>I FIND MY JOB:</u>					
DULL	12	11	0	18	29
SO-SO	7	2	0	18	14
INTERESTING	79	87	100	64	52
NO RESPONSE	2	0	0	0	5
<u>MY JOB UTILIZES MY TALENTS:</u>					
NOT AT ALL TO VERY LITTLE	21	18	0	36	48
FAIRLY WELL TO PERFECTLY	78	80	100	64	52
NO RESPONSE	1	2	0	0	0
<u>MY JOB UTILIZES MY TRAINING:</u>					
NOT AT ALL TO VERY LITTLE	18	20	0	18	43
FAIRLY WELL TO PERFECTLY	81	80	95	82	57
NO RESPONSE	1	0	5	0	0
<u>I PLAN TO REENLIST:</u>					
NO OR PROBABLY NO	56	60	45	73	33
YES OR PROBABLY YES	44	40	55	27	67
NO RESPONSE	0	0	0	0	0

TABLE A-5
BACKGROUND INFORMATION FOR SUBJOB TYPES WITHIN THE DUAL CERTIFIED CONTROLLER JOB TYPE

	DAUL CERTIFIED CONTROLLER JOB TYPES (GRP326)	PAR/GCA AND TOWER CONTROLLERS SUBJOB TYPE (GRP480)	STANDARDIZATION AND EVALUATION NCOS SUBJOB TYPE (GRP1,139)	DUAL RATED FIRST LINE SUPERVISORS SUBJOB TYPE (GRP895)	RAPCON AND TOWER CONTROLLERS SUBJOB TYPE (GRP744)
NUMBER IN GROUP	130	49	10	21	41
AVERAGE NUMBER OF TASKS PERFORMED	151	112	184	197	152
AVERAGE PAYGRADE GROUP	5.1	4.6	6.6	5.9	5.1
DAFSC					
27230	1%	2%	0	0	0
27250	45%	53%	0	24%	54%
27270	53%	43%	90%	76%	46%
27299	1%	0	10%	0	0
27200	0	0	0	0	0
OTHER	0	2%	0	0	0
AVERAGE MONTHS IN CAREER FIELD	92	79	173	122	81
AVERAGE MONTHS TAFMS	115	92	201	148	105
PERCENT IN FIRST ENLISTMENT	21%	29%	0	9%	22%
PERCENT ASSIGNED OVERSEAS	27%	33%	0	29%	17%
PERCENT WHO SUPERVISE OTHER	40%	29%	20%	67%	44%

TABLE A-6

JOB INTEREST AND RELATED DATA FOR SUBJOB TYPES WITHIN THE DUAL CERTIFIED CONTROLLER JOB TYPE
(PERCENT MEMBERS RESPONDING)

	(GRP326)	(GRP480)	(GRP1,139)	(GRP895)	(GRP744)
<u>I FIND MY JOB:</u>					
DULL	4	6	0	0	5
SO-SO	8	12	0	14	2
INTERESTING	83	80	100	76	88
NO RESPONSE	5	2	0	10	5
<u>MY JOB UTILIZES MY TALENTS:</u>					
NOT AT ALL TO VERY LITTLE	13	18	0	19	7
FAIRLY WELL TO PERFECTLY	87	82	100	81	93
NO RESPONSE	0	0	0	0	0
<u>MY JOB UTILIZES MY TRAINING:</u>					
NOT AT ALL TO VERY LITTLE	10	10	0	14	10
FAIRLY WELL TO PERFECTLY	90	90	100	86	90
NO RESPONSE	0	0	0	0	0
<u>I PLAN TO REENLIST:</u>					
NO OR PROBABLY NO	44	51	50	33	39
YES OR PROBABLY YES	56	49	50	62	61
NO RESPONSE	0	0	0	5	0

TABLE A-7

BACKGROUND INFORMATION FOR THE RAPCON CONTROLLERS, GCA/GRFC TECHNICIAN/TRAINER, RAPCON TECHNICIAN/WATCH SUPERVISOR, RADAR RANGE CONTROLLERS, AND RADAR INSTRUCTORS JOB TYPES

PAY GRADE GROUP	RAPCON CONTROLLERS (GRP488)		RAPCON OPERATORS (GRP619)		RAPCON FIRST LINE SUPERVISORS (GRP622)		GCA/GRFC TECH/TRNR JOB TYPE (GRP573)		RAPCON TECH/WATCH SUP JOB TYPE (GRP273)		RADAR RANGE CONTROLLER JOB TYPE (GRP300)		RADAR INSTRUCTORS JOB TYPES (GRP244)	
	NUMBER OF TASKS PERFORMED	PERCENT	NUMBER OF TASKS PERFORMED	PERCENT	NUMBER OF TASKS PERFORMED	PERCENT	NUMBER OF TASKS PERFORMED	PERCENT	NUMBER OF TASKS PERFORMED	PERCENT	NUMBER OF TASKS PERFORMED	PERCENT	NUMBER OF TASKS PERFORMED	PERCENT
504	504		332		168		22		11		12		17	
123	123		109		150		107		126		71		68	
4.6	4.6		4.2		5.4		5.1		6.2		4.3		4.7	
4%	4%	6%	0	0	0	0	0	0	0	0	25%	0	0	0
64%	64%	78%	35%	35%	35%	41%	41%	0	0	0	58%	65%	65%	65%
31%	31%	16%	63%	63%	63%	59%	59%	100%	100%	100%	17%	35%	35%	35%
1%	1%	0	2%	2%	2%	0	0	0	0	0	0	0	0	0
0	0	0	0	0	0	0	0	0	0	0	0	0	0	0
0	0	0	0	0	0	0	0	0	0	0	0	0	0	0
AVERAGE MONTHS IN CAREER FIELD	65		49		98		75		134		52		73	
AVERAGE MONTHS TAPMS	87		67		127		113		178		74		90	
PERCENT IN FIRST ENLISTMENT	30%		40%		8%		9%		0		42%		0	
PERCENT ASSIGNED OVERSEAS	25%		23%		29%		68%		9%		0		0	
PERCENT WHO SUPERVISE OTHERS	41%		26%		72%		64%		100%		25%		12%	

TABLE A-8

JOB INTEREST AND RELATED DATA FOR THE RAPCON CONTROLLERS, GCA/RFC TECHNICIAN/TRAINER,
RAPCON TECHNICIAN/WATCH SUPERVISOR RADAR RANGE CONTROLLERS, AND RADAR INSTRUCTORS JOB TYPES
(PERCENT MEMBERS RESPONDING)

	(GRP488)	(GRP619)	(GRP622)	(GRP573)	(GRP273)	(GRP300)	(GRP244)
<u>I FIND MY JOB:</u>							
DULL	3	3	4	5	0	0	12
SO-SO	5	5	4	14	18	8	12
INTERESTING	90	89	91	77	72	92	76
NO RESPONSE	2	3	1	4	10	0	0
<u>MY JOB UTILIZES MY TALENTS:</u>							
NOT AT ALL TO VERY LITTLE	9	8	12	14	9	8	18
FAIRLY WELL TO PERFECTLY	90	91	86	82	91	92	82
NO RESPONSE	1	1	2	4	0	0	0
<u>MY JOB UTILIZES MY TRAINING:</u>							
NOT AT ALL TO VERY LITTLE	6	6	6	9	0	8	6
FAIRLY WELL TO PERFECTLY	94	93	94	86	100	92	94
NO RESPONSE	0	1	0	5	0	0	0
<u>I PLAN TO REENLIST:</u>							
NO OR PROBABLY NO	53	57	47	36	36	75	29
YES OR PROBABLY YES	45	41	53	59	64	25	71
NO RESPONSE	2	2	0	5	0	0	0

TABLE A-7
 BACKGROUND INFORMATION FOR JOB TYPES WITHIN THE AIR TRAFFIC CONTROL SUPERVISOR AND SENIOR CONTROL TEAM CLUSTERS

	LOWER SUPERVISORS (GRP381)		SUPERVISORS (GRP619)		CHIEF CONTROLLERS JOB TYPE (GRP279)		RACON CHIEF CONTROLLERS JOB TYPE (GRP294)		SENIOR CCT MBS (GRP327)		CCT MBS (GRP329)	
	NUMBER IN GROUP	AVERAGE NUMBER OF TASKS PERFORMED	NUMBER	AVERAGE PAYGRADE GROUP	NUMBER	AVERAGE PAYGRADE GROUP	NUMBER	AVERAGE PAYGRADE GROUP	NUMBER	AVERAGE PAYGRADE GROUP	NUMBER	AVERAGE PAYGRADE GROUP
DAFSC												
27230/D	6	2%	0	0	0	0	0	0	0	0	0	0
27250/D	2%	40%	0	0	0	0	0	0	0	0	0	0
27270/D	40%	57%	0	0	0	0	0	0	0	0	0	0
27299	46%	10%	0	0	0	0	0	0	0	0	0	0
27200	10%	11%	0	0	0	0	0	0	0	0	0	0
OTHER	2%	2%	0	0	0	0	0	0	0	0	0	0
AVERAGE MONTHS IN CAREER FIELD	2.01		1.9		2.35		2.58		2.8		2.6	
AVERAGE MONTHS TAFMS	2.40		2.05		2.64		2.78		3.09		3.18	
PERCENT IN FIRST ENLISTMENT	0		0		0		0		7%		17%	
PERCENT ASSIGNED OVERSEAS	0%		34%		18%		40%		40%		39%	
PERCENT WHO SUPERVISE OTHERS	9.4%		8.3%		9.1%		9.3%		8.7%		7.8%	

TABLE A-10

JOB INTEREST AND RELATED DATA FOR JOB TYPES WITHIN THE AIR TRAFFIC CONTROL
SUPERVISOR AND COMBAT CONTROL TEAM CLUSTERS
(PERCENT MEMBERS RESPONDING)

	(GRP381)	(GRP639)	(GRP236)	(GRP279)	(GRP294)	(GRP327)	(GRP324)	(GRP154)
<u>I FIND MY JOB:</u>								
DULL	6	4	0	0	0	0	6	7
SO-SO	40	9	7	0	13	7	0	10
INTERESTING	90	83	93	91	87	93	89	83
NO RESPONSE	0	4	0	9	0	0	5	0
<u>MY JOB UTILIZES MY TALENTS:</u>								
NOT AT ALL TO VERY LITTLE	4	2	7	0	0	0	17	14
FAIRLY WELL TO PERFECTLY	96	96	93	91	93	93	78	86
NO RESPONSE	0	2	0	9	7	7	5	0
<u>MY JOB UTILIZES MY TRAINING:</u>								
NOT AT ALL TO VERY LITTLE	4	2	7	0	7	13	17	14
FAIRLY WELL TO PERFECTLY	96	96	93	100	93	87	83	83
NO RESPONSE	0	2	0	0	0	0	0	3
<u>I PLAN TO REENLIST:</u>								
NO OR PROBABLY TO	46	43	20	64	74	20	33	45
YES OR PROBABLY YES	52	55	80	18	26	80	67	55
NO RESPONSE	2	2	0	18	0	0	0	0

APPENDIX B

Computer matching of percent of first enlistment and 5-skill level personnel performing inventory tasks by Control Tower, Radar Air Traffic Control, and Combat Control Team Personnel Cluster groups.

INVENTORY ORDER OF 272XD/D TASKS

B2 THIS IS A REPORT IN INVENTORY ORDER OF 272XD/D TASKS USING TOTAL SAMPLE, CONTROL TOWER, RADAR CONTROL, AND CCT 1ST ENLISTMENT AND 5-SKILL LEVEL GROUPS.

D-TASK	TITLES	TS		CT		CCT		RC		CT		CCT	
		TEL	TEL	TEL	TEL	TEL	TEL	TEL	TEL	TEL	TEL	TEL	TEL
A	ORGANIZING AND PLANNING												
A 1	ASSIGN PERSONNEL TO DUTY POSITIONS	2.8	3.6	2.4	2.4	.0	.0	10.4	15.3	18.2			
A 2	ASSIGN SPONSORS FOR NEWLY ASSIGNED PERSONNEL	2.1	2.4	2.0	2.0	.0	.0	3.0	2.7	6.1			
A 3	COORDINATE AIR TRAFFIC CONTROL (ATC) PROCEDURES FOR DISASTER CONTROL EXERCISES WITH OTHER AGENCIES	11.2	16.5	7.3	7.3	7.7	7.7	18.4	8.2	9.1			
A 4	COORDINATE AIRLIFT CONTROL PRIORITIES WITH BASE FLYING AUTHORITIES	11.5	15.3	10.1	10.1	.0	.0	13.4	10.3	3.0			
A 5	COORDINATE AIRLIFT OPERATIONS WITH OTHER AGENCIES, SUCH AS COMMAND POSTS OR AIRLIFT CONTROL CENTERS (ALCC)	5.5	6.5	4.8	4.8	7.7	7.7	6.3	5.2	18.2			
A 6	COORDINATE REVISIONS FOR SPECIAL OPERATIONS WITH FEDERAL AVIATION ADMINISTRATION (FAA) CENTERS	4.4	4.4	4.8	4.8	.0	.0	4.1	5.2	3.0			
A 7	COORDINATE REVISIONS FOR SPECIAL OPERATIONS WITH BASE FLYING AUTHORITIES	5.5	7.3	4.4	4.4	.0	.0	6.6	4.9	3.0			
A 8	DESIGN MAP OVERLAYS	1.6	1.2	1.6	1.6	.0	.0	1.4	2.5	3.0			
A 9	DETERMINE REQUIREMENTS FOR SPACE, PERSONNEL, EQUIPMENT, OR SUPPLIES	3.2	2.8	2.0	2.0	23.1	23.1	3.0	3.1	30.3			
A 10	DETERMINE WORK PRIORITIES	12.6	13.7	10.5	10.5	30.8	30.8	17.8	15.7	45.5			
A 11	DEVELOP FACILITY REFERENCE CHARTS	3.9	3.2	4.4	4.4	7.7	7.7	4.9	5.0	9.1			
A 12	DEVELOP ORGANIZATIONAL CHARTS	1.6	.4	2.0	2.0	7.7	7.7	1.6	1.7	15.2			
A 13	DEVELOP SEARCH RADAR MEMORANDUM ALTITUDE VECTORING CHARTS	1.6	.4	2.0	2.0	.0	.0	1.6	2.3	3.0			
A 14	DEVELOP WORK METHODS OR PROCEDURES	6.4	5.6	5.6	5.6	15.4	15.4	7.1	11.7	36.4			
A 15	DRAFT BUDGETS OR FINANCIAL REQUIREMENTS	1.2	.4	1.6	1.6	.0	.0	1.4	1.6	6.1			
A 16	ESTABLISH FACILITY DOCUMENTATION FILES	2.7	2.0	2.4	2.4	7.7	7.7	1.9	2.5	6.1			
A 17	ESTABLISH FACILITY MISSION IMPACT GUIDELINES	.9	.4	.8	.8	.0	.0	.8	1.0	3.0			
A 18	ESTABLISH ORGANIZATIONAL POLICIES, OFFICE INSTRUCTIONS (OI), OR STANDARD OPERATING PROCEDURES (SOP)	1.9	1.2	1.2	1.2	7.7	7.7	2.2	1.7	27.3			
A 19	ESTABLISH PERFORMANCE STANDARDS FOR SUBORDINATES	.2	2.4	3.2	3.2	15.4	15.4	6.0	8.5	30.3			
A 20	ESTABLISH PRIORITIES FOR RESTORING EQUIPMENT	2.5	2.4	2.4	2.4	.0	.0	4.1	3.9	12.1			
A 21	ESTABLISH PROCEDURES FOR CONTROLLING FLIGHT CHECK AIRCRAFT	3.0	3.2	2.8	2.8	.0	.0	4.1	2.9	3.0			
A 22	ESTABLISH PROCEDURES FOR CONTROLLING TRAFFIC BETWEEN SECTORS AND OTHER FACILITIES	3.5	2.0	5.2	5.2	.0	.0	2.5	5.4	3.0			
A 23	ESTABLISH PROCEDURES FOR CONTROLLING TRAFFIC BETWEEN SECTORS	3.2	1.2	4.8	4.8	.0	.0	1.6	5.0	3.0			
A 24	ESTABLISH PROCEDURES FOR NOTIFYING OTHER AGENCIES OF EQUIPMENT FAILURES	5.7	6.5	5.2	5.2	.0	.0	6.0	5.4	6.1			
A 25	ESTABLISH PUBLICATION LIBRARIES	3.2	2.8	2.8	2.8	.0	.0	4.1	4.7	9.1			
A 26	PLAN AIRCRAFT LOADING OR UNLOADING	1.4	.8	.8	.8	30.8	30.8	.8	1.2	24.2			
A 27	PLAN BRIEFINGS	3.7	.4	3.6	3.6	69.2	69.2	2.7	7.6	54.5			
A 28	PLAN FACILITY EQUIPMENT LAYOUTS	1.2	.8	.8	.8	7.7	7.7	.5	1.6	6.1			
A 29	PLAN LAYOUTS OF FACILITIES	.7	.0	.8	.8	.0	.0	.8	1.2	3.0			
A 30	PLAN SAFETY PROGRAMS	1.6	.4	2.4	2.4	.0	.0	2.2	3.7	6.1			
A 31	PLAN SECURITY PROGRAMS	1.4	.3	.8	.8	7.7	7.7	1.6	1.0	6.1			
A 32	PLAN WORK ASSIGNMENTS	4.2	3.2	4.8	4.8	7.7	7.7	5.5	8.2	15.2			
A 33	PREPARE AND SUBMIT RECOMMENDATIONS FOR IMPROVING AND STANDARDIZING AIR TRAFFIC CONTROL PROCEDURES	6.7	5.6	8.1	8.1	.0	.0	9.9	12.6	3.0			
A 34	PREPARE FACILITY CHECKLISTS	6.2	7.3	5.2	5.2	.0	.0	7.9	7.3	6.1			
A 35	PREPARE JOB DESCRIPTIONS	.7	.0	.8	.8	.0	.0	.3	2.1	.0			

INVENTORY ORDER OF 272XD/D TASKS

THIS IS A REPORT IN INVENTORY ORDER OF 272XD/D TASKS USING LOCAL SAMPLE, CONTROL TOWER, RADAR CONTROL, AND CCT 1ST ENLISTMENT AND 5-SKILL LEVEL GROUPS.

D-ISM	TITLES	TS		RC		CCT		CT		CC	
		TEL (M)	TEL (H)	TEL (M)	TEL (H)	TEL (M)	TEL (H)	TEL (M)	TEL (H)	TEL (M)	TEL (H)
A 36	PREPARE RECOMMENDATIONS FOR CHANGES TO ATC EQUIPMENT TO BASES OR OTHER AGENCIES	1.4	.8	1.2	.0	1.4	1.9	.0			
A 37	PREPARE RECOMMENDATIONS FOR CHANGES TO NAVIGATIONAL AIDS (NAVAID) TO BASES OR OTHER AGENCIES	1.2	.8	.8	.0	.5	1.0	.0			
A 38	PREPARE REQUESTS FOR UNIT DETAIL LISTINGS (UDL) CHANGES	1.1	.4	.8	.0	.3	.8	.0			
A 39	PREPARE UNIT EMERGENCY PLANS	1.1	.8	.4	.0	1.4	.6	.0			
A 40	PREPARE WORK REQUESTS TO BASE SERVICE ORGANIZATIONS	1.4	.4	1.2	7.7	1.6	1.2	9.1			
A 41	SCHEDULE ATC MEETINGS	.9	.0	.8	.0	1.1	1.2	.0			
A 42	SCHEDULE BRIEFINGS	1.6	.0	1.2	23.1	1.1	2.5	18.2			
A 43	SCHEDULE LEAVES OR PASSES	1.2	.0	1.2	.0	1.1	1.7	.0			

B	DIRECTING IMPLEMENTING										

B 44	CONDUCT BRIEFINGS FOR NEWLY ASSIGNED PILOTS ON LOCAL ATC POLICIES AND PROCEDURES	7.4	6.0	9.3	.0	7.9	14.6	.0			
B 45	CONDUCT BRIEFINGS ON STATUS OF ATC	3.5	2.8	3.6	.0	2.5	6.0	3.0			
B 46	CONDUCT BRIEFINGS ON SUPPLIES	1.9	2.0	.8	.0	1.4	.8	3.0			
B 47	CONDUCT FACILITY TOURS	53.5	53.2	60.9	23.1	57.3	65.4	15.2			
B 48	CONDUCT STAFF MEETINGS	.7	.0	.8	.0	.0	1.2	3.0			
B 49	COUNSEL PERSONNEL ON PERSONAL OR MILITARY RELATED PROBLEMS	4.2	3.6	4.0	15.4	11.0	18.3	24.2			
B 50	DIRECT AIR TRAFFIC REGULATION CENTER (ATRC) ACTIVITIES	.9	.0	.8	.0	.0	1.2	.0			
B 51	DIRECT COMBAT CONTROL CONTINUATION TRAINING	1.4	.0	1.2	15.4	.3	.8	24.2			
B 52	DIRECT CONVENTIONAL AIR ROUTE TRAFFIC CONTROL ACTIVITIES	3.4	2.0	4.0	.0	1.9	5.2	.0			
B 53	DIRECT DEVELOPMENT OR MAINTENANCE OF STATUS BOARDS, GRAPHS, OR CHARTS	3.4	2.4	2.8	7.7	3.6	3.5	18.2			
B 54	DIRECT DIRECTIONAL FINDING (DF) ACTIVITIES	2.1	1.6	1.6	7.7	1.1	1.2	3.0			
B 55	DIRECT GROUND CONTROLLED APPROACH (GCA) ACTIVITIES	4.6	.8	7.3	.0	1.6	9.7	.0			
B 56	DIRECT INSTRUMENT METEOROLOGICAL CONDITION (IMC) APPROACH CONTROL TOWER ACTIVITIES	1.4	1.2	.8	.0	1.4	.8	.0			
B 57	DIRECT MAINTENANCE OF ADMINISTRATIVE FILES	1.2	.4	1.2	.0	1.9	1.9	12.1			
B 58	DIRECT NONRADAR APPROACH CONTROL ACTIVITIES	7.6	2.0	14.1	.0	3.0	15.3	.0			
B 59	DIRECT PRECISION APPROACH RADAR ACTIVITIES	11.2	1.2	23.0	.0	1.9	26.8	.0			
B 60	DIRECT PROCEDURES FOR PERFORMING EQUIPMENT CHECKS	7.3	6.0	8.5	.0	6.6	9.7	.0			
B 61	DIRECT RADAR AIR ROUTE TRAFFIC CONTROL ACTIVITIES	2.3	.4	3.2	.0	.3	3.9	.0			
B 62	DIRECT RADAR APPROACH CONTROL (RAPCON) ACTIVITIES	9.4	.8	19.0	.0	.8	22.1	.0			
B 63	DIRECT VISUAL METEOROLOGICAL CONDITIONS (VMC) CONTROL TOWER ACTIVITIES	7.8	13.3	3.6	.0	17.5	2.9	6.1			
B 64	IMPLEMENT CHANGES TO FLIGHT INFORMATION PUBLICATIONS (FLIP)	1.2	.4	1.6	.0	1.1	1.7	.0			
B 65	IMPLEMENT COST REDUCTION PROGRAMS	1.6	1.2	1.6	.0	1.6	1.7	.0			
B 66	IMPLEMENT SAFETY PROGRAMS	3.2	2.4	4.0	.0	5.2	6.4	6.1			
B 67	IMPLEMENT SECURITY PROGRAMS	2.3	2.0	2.4	.0	3.0	3.3	6.1			
B 68	IMPLEMENT SUGGESTION PROGRAMS	3.7	3.2	4.0	.0	4.9	4.9	3.0			
B 69	INITIATE CORRECTIVE ACTIONS BASED ON INSPECTION DEFICIENCY REPORTS	1.8	.8	1.6	7.7	1.9	2.1	12.1			

INVENTORY ORDER OF 272X0/D TASKS

THIS IS A REPORT IN INVENTORY ORDER OF 272X0/D TASKS USING TOTAL SAMPLE, CONTROL TOWER, RADAR CONTROL, AND CCT 1ST ENLISTMENT AND 5-SKILL LEVEL GROUPS.

D	TASK	TITLES	TS		RC		CCT		CT		RC		CCT	
			TEL (M)	TEL (M)	TEL (M)	TEL (M)	TEL (M)	TEL (M)	TEL (M)	TEL (M)	TEL (M)	TEL (M)	TEL (M)	TEL (M)
B	70	INITIATE PERSONNEL ACTION REQUESTS	1.1	.0	1.2	.0	.5	1.4	3.0					
B	71	INTERPRET ATC POLICIES FOR USING ACTIVITIES	6.0	5.6	6.9	.0	7.1	7.2	.0					
B	72	INTERPRET POLICIES, DIRECTIVES, OR PROCEDURES FOR SUBORDINATES	6.7	4.8	9.7	.0	9.9	16.1	15.2					
B	73	INVENTORY EQUIPMENT, TOOLS, OR SUPPLIES OTHER THAN MOBILE EQUIPMENT, TOOLS, OR SUPPLIES	3.9	4.0	3.2	15.4	4.1	3.5	21.2					
B	74	INVENTORY MOBILE EQUIPMENT, TOOLS OR SUPPLIES	2.3	.8	2.0	23.1	1.1	1.6	21.2					
B	75	MAINTAIN ATC LIAISON WITH FOREIGN NATIONALS	1.8	1.6	1.2	.0	1.6	2.5	.0					
B	76	MAINTAIN ATC LIAISON WITH OTHER UNITED STATES AGENCIES	1.8	1.2	1.2	.0	1.1	1.6	.0					
B	77	MAINTAIN CONTINGENCY PLANS	1.2	.8	1.2	.0	1.4	1.0	.0					
B	78	MAINTAIN FACILITY STATUS BOARDS	19.3	27.4	14.1	.0	31.5	19.2	9.1					
B	79	MAINTAIN NAVAID STATUS CHARTS	10.4	15.7	6.5	.0	14.8	9.3	.0					
B	80	MAINTAIN RECORDS OF FACILITY OPERATIONS	14.5	21.4	10.1	.0	20.0	14.2	3.0					
B	81	MAINTAIN REPORT CONTROL SYMBOL (RCS) BOARDS	.9	.0	1.2	.0	.3	.6	.0					
B	82	POST FACILITY DUTY SCHEDULES	2.1	2.0	2.0	.0	2.7	2.3	9.1					
B	83	PREPARE AND SUBMIT RECOMMENDATIONS FOR CHANGES TO BASE ATC MANUALS	1.8	1.2	1.6	.0	2.5	3.3	.0					
B	84	PREPARE AND SUBMIT TERMINAL INSTRUMENT PROCEDURE (TERPS) PACKAGES	1.1	.4	1.2	.0	1.1	1.7	.0					
B	85	REVIEW TERPS PACKAGES	1.1	.8	.8	.0	1.1	1.7	.0					
B	86	REVIEW FACILITY EQUIPMENT LAYOUTS	.7	.0	.8	.0	.5	1.2	.0					
B	87	SUPERVISE AIR TRAFFIC CONTROL OPERATORS (AFSC 27250)	7.6	5.6	10.1	.0	14.2	21.7	9.1					
B	98	SUPERVISE AIR TRAFFIC CONTROL SUPERINTENDENTS (AFSC 27299)	1.2	.0	2.0	.0	.3	2.1	.0					
B	89	SUPERVISE AIR TRAFFIC CONTROL TECHNICIANS (AFSC 27270)	1.8	1.2	2.0	.0	3.0	3.5	.0					
B	90	SUPERVISE APPRENTICE AIR TRAFFIC CONTROL OPERATORS (AFSC 27230)	28.3	30.6	32.3	.0	46.0	45.2	6.1					
B	91	SUPERVISE APPRENTICE COMBAT CONTROL TEAM OPERATOR (AFSC 27230)	3.2	2.4	2.8	23.1	2.7	2.3	42.4					
B	92	SUPERVISE CIVILIAN PERSONNEL	1.1	.4	1.2	.0	.5	.6	.0					
B	93	SUPERVISE COMBAT CONTROL TEAM OPERATORS (AFSC 27250)	1.4	.8	.9	15.4	1.4	.6	36.4					
B	94	SUPERVISE COMBAT CONTROL TEAM TECHNICIANS (AFSC 27270)	.5	.4	.4	.0	.5	.2	.0					
B	95	SUPERVISE MILITARY PERSONNEL WITH AFSCS OTHER THAN 272X0/D	.9	.4	.8	.0	1.1	1.4	3.0					
B	95	WRITE GENERAL CORRESPONDENCE	4.8	2.4	6.5	15.4	4.9	6.8	39.4					
C		INSPECTING AND EVALUATING												
C	97	ADMINISTER FACILITY RATING EXAMINATIONS	1.6	2.0	.8	.0	1.9	1.2	.0					
C	98	CONDUCT ATC FACILITY SELF INSPECTIONS	3.4	3.2	3.2	.0	5.2	6.2	.0					
C	99	EVALUATE ACTIVITY REPORTS	.9	.0	1.2	.0	.0	.6	3.0					
C	100	EVALUATE AIRCRAFT SAVE REQUESTS	.7	.0	.8	.0	.3	.4	.0					
C	101	EVALUATE ATC COMPLAINTS	.7	.0	.8	.0	.5	1.7	.0					
C	102	EVALUATE ATC METHODS OR TECHNIQUES	3.0	1.2	4.4	.0	1.9	4.7	.0					
C	103	EVALUATE ATC OPERATIONS REPORTS	1.1	.0	1.2	.0	1.1	1.6	.0					
C	104	EVALUATE AIC PROBLEM AREAS	2.1	.8	2.8	.0	1.6	3.5	9.1					

INVENTORY ORDER OF 272XC/D TASKS

THIS IS A REPORT IN INVENTORY ORDER OF 272XC/D TASKS LISTING TOTAL TIME, LEVEL, CONTROL TOWER, RADAR CONTROL, AND CCT 1ST ENLISTMENT AND 5-SKILL LEVEL GROUPS.

B5

D. TASK	TITLES	TS		CCT		RC		CT		CCT	
		TEL (M)	REL (H)	TEL (M)	REL (H)	TEL (M)	REL (H)	TEL (M)	REL (H)	TEL (M)	REL (H)
C 105	EVALUATE ATC RECOMMENDATIONS	1.1	.4	1.6	.0	.8	1.9	3.0	.0	.0	3.0
C 106	EVALUATE ATC VOICE-REORDER TAPES	12.2	9.3	17.3	.0	7.9	15.3	3.0	.0	.0	3.0
C 107	EVALUATE BUDGETS OR FINANCIAL REQUIREMENTS	.5	.4	.4	.0	.5	.2	3.0	.0	.0	3.0
C 108	EVALUATE COMPLIANCE WITH PERFORMANCE STANDARDS	2.3	1.6	2.8	.0	4.1	3.9	6.1	.0	.0	6.1
C 109	EVALUATE FACILITY LETTERS OF AGREEMENT	3.5	3.2	3.6	.0	5.8	6.6	3.0	.0	.0	3.0
C 110	EVALUATE FACILITY MEMORANDA	4.1	4.8	5.2	.0	6.6	6.2	3.0	.0	.0	3.0
C 111	EVALUATE FACILITY OPERATION LETTERS	5.1	4.8	5.2	7.7	7.1	7.8	3.0	.0	.0	3.0
C 112	EVALUATE INDIVIDUALS FOR PROMOTIONS, DEMOTIONS, OR RECLASSIFICATIONS	.9	.4	.8	.0	2.5	1.2	6.1	.0	.0	6.1
C 113	EVALUATE INDIVIDUALS FOR SPECIALIZED TRAINING	2.1	1.2	2.8	.0	3.0	2.9	3.0	.0	.0	3.0
C 114	EVALUATE INSPECTION REPORTS OR PROCEDURES	1.4	.8	1.2	.0	.8	1.2	.0	.0	.0	.0
C 115	EVALUATE JOB DESCRIPTIONS	1.2	.4	1.2	.0	1.4	1.7	.0	.0	.0	.0
C 116	EVALUATE MAINTENANCE OR USE OF WORKSPACE, EQUIPMENT, OR SUPPLIES	1.6	.8	2.0	.0	1.6	1.7	3.0	.0	.0	3.0
C 117	EVALUATE MISSION IMPACT RESULTING FROM INOPERATIVE CONTROL FACILITIES	1.8	1.6	1.6	.0	2.2	1.2	.0	.0	.0	.0
C 118	EVALUATE PROCEDURES FOR STORAGE, INVENTORY, OR INSPECTION OF PROPERTY ITEMS	1.2	.4	1.6	.0	.3	1.4	3.0	.0	.0	3.0
C 119	EVALUATE SAFETY PROGRAMS	1.6	.8	2.0	.0	1.9	2.7	.0	.0	.0	.0
C 120	EVALUATE SECURITY PROGRAMS	.9	.4	.8	.0	.3	1.2	.0	.0	.0	.0
C 121	EVALUATE SUGGESTIONS	1.4	.4	2.0	.0	.8	1.7	.0	.0	.0	.0
C 122	EVALUATE UNIT EMERGENCY PLANS	1.1	.4	1.2	.0	1.1	1.0	.0	.0	.0	.0
C 123	EVALUATE WORK SCHEDULES	1.9	1.6	2.0	.0	2.2	1.9	9.1	.0	.0	9.1
C 124	EVALUATE WORKLOAD REQUIREMENTS	1.2	.8	1.2	.0	.3	1.2	12.1	.0	.0	12.1
C 125	INVESTIGATE ACCIDENTS OR INCIDENTS OTHER THAN AIRCRAFT ACCIDENTS OR INCIDENTS	1.4	.8	1.6	.0	1.4	1.4	.0	.0	.0	.0
C 126	INVESTIGATE AIRCRAFT ACCIDENTS OR INCIDENTS	.7	.0	.8	.0	.0	1.0	.0	.0	.0	.0
C 127	PERFORM ON-THE-JOB PERFORMANCE EVALUATIONS OF AIR TRAFFIC CONTROLLERS	17.2	18.1	19.0	.0	26.5	32.0	9.1	.0	.0	9.1
C 128	PREPARE APPRAISALS	1.8	1.2	2.0	.0	9.0	19.0	36.4	.0	.0	36.4
C 129	WRITE CIVILIAN PERFORMANCE RATINGS OR SUPERVISORY APPRAISALS	.0	.0	1.2	.0	.3	.8	.0	.0	.0	.0
C 130	WRITE STAFF STUDIES, SURVEYS, OR SPECIAL REPORTS	1.2	.8	1.2	.0	1.1	1.6	6.1	.0	.0	6.1
D TRAINING											
D 131	ADMINISTER TESTS	7.8	6.5	9.3	7.7	11.0	15.1	15.2	.0	.0	15.2
D 132	ASSIGN ON-THE-JOB TRAINING (OJT) TRAINERS	2.5	2.4	2.4	.0	3.0	4.5	3.0	.0	.0	3.0
D 133	ASSIGN RESIDENT COURSE INSTRUCTORS	.7	.0	.8	.0	.0	.8	.0	.0	.0	.0
D 134	CONDUCT AIR NATIONAL GUARD OR AIR FORCE RESERVES AIR TRAFFIC CONTROL (ATC) TRAINING	1.6	1.5	2.0	.0	1.9	3.1	.0	.0	.0	.0
D 135	CONDUCT ATC EXERCISES	6.0	6.9	5.6	.0	6.8	5.4	3.0	.0	.0	3.0
D 136	CONDUCT ATC TRAINING FOR FOREIGN NATIONALS	2.7	.8	4.0	.0	2.2	8.3	.0	.0	.0	.0
D 137	CONDUCT BRIEFINGS ON NEW TRAINING TECHNIQUES	2.8	1.6	3.2	.0	3.8	6.2	9.1	.0	.0	9.1
D 138	CONDUCT CONTROL TOWER PROFICIENCY TRAINING	5.3	8.9	2.4	.0	12.6	2.5	3.0	.0	.0	3.0

THIS IS A REPORT IN INVENTORY ORDER OF 272X/D TASKS USING TOTAL SAMPLE, CONTROL TOWER, RADAR CONTROL, AND CCT 1ST ENLISTMENT AND 5-SKILL LEVEL GROUPS.

D TASK	TITLES	TS		RC		CCT		CT		RC		CCT	
		1EL (H)	1EL (M)	1EL (H)	1EL (M)	1EL (H)	1EL (M)	1EL (H)	1EL (M)	1EL (H)	1EL (M)	1EL (H)	1EL (M)
D 139	CONDUCT FACILITY RATING TRAINING	12.7	10.1	17.7	.0	13.7	22.7	.0					
D 140	CONDUCT GCA PROFICIENCY TRAINING	2.5	.0	4.8	.0	.3	6.4	.0					
D 141	CONDUCT RAPCON PROFICIENCY TRAINING	5.3	.0	11.3	.0	.0	19.8	.0					
D 142	CONDUCT RESIDENT COURSE CLASSROOM TRAINING	1.9	.4	1.2	15.4	1.6	2.9	15.2					
D 143	CONDUCT TERMINAL RADAR ATC PROFICIENCY TRAINING	3.7	.0	7.3	.0	.0	11.1	.0					
D 144	CONDUCT WEAPONS PROFICIENCY TRAINING OTHER THAN COMBAT CONTROL	.9	.0	.8	.0	.0	.4	3.0					
D 145	COORDINATE COMBAT CONTROL TRAINING AREAS	1.2	.0	.8	15.4	.3	.6	30.3					
D 146	COUNSEL TRAINEES ON TRAINING PROGRESS	26.0	22.6	33.9	7.7	36.4	47.6	27.3					
D 147	DEMONSTRATE HOW TO LOCATE TECHNICAL INFORMATION	16.5	15.7	20.2	.0	25.8	30.9	24.2					
D 148	DETERMINE OJT TRAINING REQUIREMENTS	3.2	2.0	4.0	.0	6.0	6.6	18.2					
D 149	DETERMINE RESIDENT COURSE TRAINING REQUIREMENTS	1.2	.4	1.2	.0	1.4	2.9	.0					
D 150	DEVELOP RESIDENT COURSE OR CAREER DEVELOPMENT COURSE (CDC) CURRICULUM MATERIAL	.9	.0	.8	.0	.0	.6	.0					
D 151	DIRECT OR IMPLEMENT OJT PROGRAMS	4.2	4.4	4.4	.0	6.8	9.5	18.2					
D 152	DIRECT OR IMPLEMENT TRAINING PROGRAMS OTHER THAN OJT	1.6	1.2	1.6	.0	2.7	4.1	21.2					
D 153	ESTABLISH STUDY REFERENCE FILES	2.5	2.6	1.6	7.7	2.7	3.3	15.2					
D 154	ESTABLISH UNIT TRAINING REQUIREMENTS	.9	.4	.4	7.7	.5	.4	12.1					
D 155	EVALUATE OJT TRAINEES	20.0	21.0	23.4	.0	31.0	34.4	24.2					
D 156	EVALUATE PROGRESS OF RESIDENT COURSE STUDENTS	2.7	1.6	3.2	.0	3.6	4.9	.0					
D 157	EVALUATE TRAINING METHODS OR TECHNIQUES	4.8	4.4	4.8	7.7	6.0	6.2	18.2					
D 158	MAINTAIN TRAINING RECORDS, CHARTS, OR GRAPHS	28.7	30.2	31.9	15.4	40.3	44.5	36.4					
D 159	MONITOR COMPLIANCE WITH UNIT JOB PROFICIENCY STANDARDS	3.4	4.0	2.8	.0	6.6	7.6	9.1					
D 160	MONITOR FACILITY RATING TRAINING	6.2	6.1	4.4	.0	10.7	9.5	3.0					
D 161	PLAN OJT	3.0	1.2	4.8	.0	3.3	7.8	3.0					
D 162	PREPARE FACILITY TRAINING GUIDES	1.6	.4	2.4	.0	1.6	3.5	3.0					
D 163	PREPARE LESSON PLANS	5.7	3.6	6.5	23.1	6.8	11.1	30.3					
D 164	PREPARE TRAINING SCHEDULES	2.7	2.0	2.8	7.7	4.1	5.4	24.2					
D 165	PROCURE TRAINING AIDS, SPACE, OR EQUIPMENT	3.2	2.8	2.8	15.4	4.4	4.9	27.3					
D 166	SCHEDULE PERSONNEL FOR CDC COURSES	1.6	1.6	1.2	.0	3.3	1.7	12.1					
D 167	SCORE TESTS	3.0	3.2	2.0	7.7	5.2	5.8	15.2					
D 168	UPDATE FACILITY RATING SUSPENSE FILES	1.2	1.2	.8	.0	.8	.6	.0					
D 169	UPDATE OJT RECORDS	11.3	10.9	13.3	.0	17.5	20.6	21.2					
D 170	WRITE TEST QUESTIONS	10.1	11.3	9.7	15.4	15.3	16.1	24.2					
D 171	WRITE TRAINING REPORTS	11.0	9.3	14.5	7.7	15.6	23.4	21.2					

E WORKING WITH FORMS, RECORDS, REPORTS, DIRECTIVES
TECHNICAL DATA

E 172	ANNOTATE FLIGHT PROGRESS STRIP (FAA FORM 7230-8)	58.8	61.3	64.5	7.7	70.1	73.4	9.1					
E 173	ANNOTATE FLIGHT PROGRESS STRIP FORMS (FAA FORM 566-41)	3.9	2.6	4.8	.0	2.2	3.7	.0					
E 174	ANNOTATE INDIVIDUAL JUMP RECORD FORMS (AF FORM 922)	1.1	.0	1.2	15.4	.5	.6	42.4					
E 175	ANNOTATE RADAR OPERATIONS LOG (LRA) FORMS (AF FORM 1131)	5.5	.4	10.5	.0	.5	12.2	.0					
E 176	COMPLETE FLIGHT MANAGEMENT/TRAINING/EVALUATION RECORDS FORMS (LAF FORM 8461)	.9	.4	.8	.0	.5	.4	21.2					

INVENTORY ORDER OF 272X0/D TASKS

THIS IS A REPORT IN INVENTORY ORDER OF 272X0/D TASKS USING TOTAL SAMPLE, CONTROL TOWER, RADAR CONTROL, AND CCT 157 ENLISTMENT AND 5-SKILL LEVEL GROUPS.

B7

JOB TASK	TITLE		TS (M)	RC IEL (P)	CCT IEL (M)	CT SD (M)	RC SO (M)	CCT SO (M)
	IS (M)	IEL (M)						
E 177	FILE OBSERVED ROCKET OR ARTILLERY FIRE REPORTS	.5	.0	.8	.0	.3	.6	6.1
E 178	MAINTAIN MEDICAL RECOMMENDATION FOR FLYING OR SPECIAL OPERATIONS DUTY FORMS (AF FORM 042)	1.8	1.2	2.0	.0	1.4	1.6	18.2
E 179	PREPARE AEROSPACE VEHICLE FLIGHT REPORT AND MAINTENANCE DOCUMENT FORMS (AFTO FORM 781F)	.5	.4	.4	.0	.3	.2	6.1
E 180	PREPARE AIR TRAFFIC CONTROLLER EVALUATION RECORD FORMS	7.4	7.7	8.1	.0	12.9	13.8	.0
E 181	PREPARE AIRCRAFT ACCIDENTS OR INCIDENTS BRIEFS	1.4	.4	1.6	.0	2.2	1.9	.0
E 182	PREPARE AND INITIATE USAF HAZARD REPORT FORMS (AF FORM 457)	3.0	3.6	2.4	.0	6.6	5.0	3.0
E 183	PREPARE ANNUAL TEAM DEPLOYMENT TRAINING FORMS	.7	.0	.4	7.7	.0	.2	18.2
E 184	PREPARE ASSAULT ASSESSMENT FORMS (MAC FORM 16.)	1.8	.0	.4	46.2	.0	.2	63.6
E 185	PREPARE ASSAULT ZONE SURVEY FORMS	1.4	.0	.4	38.5	.0	.2	39.4
E 186	PREPARE ATC WEATHER CERTIFICATION FORMS	1.2	.8	.8	7.7	2.2	.6	15.2
E 187	PREPARE AUTOMATIC RIPCORD RELEASE LOG FORMS (AFTO FORM 393)	1.5	.0	.8	30.8	.0	.4	21.2
E 188	PREPARE DATA BASE CHANGE REQUEST (DBCR) FORMS (AF FORM 1776)	.9	.4	.3	.0	.3	.4	.0
E 189	PREPARE FAA FACILITY CERTIFICATION APPLICATIONS	.9	.0	1.2	.0	.0	.6	.0
E 190	PREPARE FACILITY MEMORANDA	2.3	1.6	2.0	7.7	1.6	1.7	.0
E 191	PREPARE FACILITY REPORTS	2.5	2.4	2.0	.0	2.5	2.1	.0
E 192	PREPARE HISTORICAL RECORDS OF PHASE III COMBAT READY STATUS FORMS	.9	.0	1.2	.0	.0	.6	18.2
E 193	PREPARE INDIVIDUAL PHYSIOLOGICAL TRAINING RECORD FORMS (AF FORM 702)	1.2	.4	1.2	7.7	.5	.6	12.1
E 194	PREPARE LETTERS OF AGREEMENT	1.2	.4	1.2	.0	.8	1.4	.0
E 195	PREPARE MILITARY SHIPMENT LABEL (FOR PRIORITY SHIPMENTS) FORMS (DD FORM 1387)	1.2	.4	.8	15.4	.5	.4	18.2
E 196	PREPARE OPERATOR'S INSPECTION GUIDE AND TROUBLE REPORT (GENERAL PURPOSE VEHICLES) FORMS (AFTO FORM 374)	2.7	.8	1.6	46.2	1.1	1.6	57.6
E 197	PREPARE OP REVIEW SERVICE EVALUATION REPORTS	1.8	1.2	1.6	.0	1.6	2.3	.0
E 198	PREPARE OUTAGE LOG FORMS	34.5	38.3	35.5	7.7	44.1	43.3	3.0
E 199	PREPARE PARACHUTE LOG FORMS (AFTO FORM 351)	3.2	.4	1.2	84.6	.5	.6	84.9
E 200	PREPARE PARACHUTE REPACK, INSPECTION AND COMPONENT RECORD FORMS (AFTO FORM 392)	2.8	.0	.8	84.6	.3	.6	84.9
E 201	PREPARE PHASE II TRAINING CERTIFICATES	.7	.4	.8	.0	.3	.6	9.1
E 202	PREPARE POSITION LOG FORMS (AF FORM 1134)	61.8	71.4	61.7	7.7	75.6	66.4	6.1
E 203	PREPARE PRIOR EXPERIENCE CERTIFICATES	.7	.4	.8	.0	.5	.6	18.2
E 204	PREPARE QUARTERLY TRAINING REPORTS	2.1	2.0	2.0	7.7	2.2	2.5	15.2
E 205	PREPARE RECOMMENDATIONS FOR STANDARDIZATION OF FACILITY PROCEDURES	2.7	2.4	2.4	.0	2.7	5.0	.0
E 206	PREPARE SECURITY INSPECTION FORMS	.5	.0	.8	.0	.3	1.0	.0
E 207	PREPARE STANDARDIZATION CHECK FORMS	.9	.0	1.2	.0	.3	1.4	15.2
E 208	PREPARE SYSTEM/EQUIPMENT STATUS RECORD FORMS (AFTO FORM 244)	1.4	.8	1.6	.0	1.4	1.2	.0
E 209	PREPARE TRAFFIC COUNT FORMS	49.4	52.0	55.6	.0	51.5	54.6	3.0
E 210	REVIEW FAA REFRESHER BRIEFING SERVICES PAMPHLETS	20.7	21.0	23.4	.0	25.8	29.7	.0
E 211	REVIEW RADAR OPERATIONS LOG (LRA) FORMS (AF FORM 1131)	4.8	.8	8.1	.0	1.6	8.3	.0
E 212	UPDATE ALTITUDE CLEARANCE DATA	17.0	13.7	22.6	.0	10.4	19.8	.0

INVENTORY ORDER OF 272XD/D TASKS

THIS IS A REPORT IN INVENTORY ORDER OF 272XD/D TASKS USING TOTAL SAMPLE,
CONTROL TOWER, RADAR CONTROL, A D CCT 1ST ENLISTMENT AND 5-SKILL LEVEL GROUPS.

D ISK	TITLES	IS		RC		CCT		CT		RC		CCT	
		TEL (M)	TEL (M)	TEL (M)	TEL (M)	TEL (M)	TEL (M)	TEL (M)	TEL (M)	TEL (M)	TEL (M)	TEL (M)	TEL (M)
E 213	UPDATE EVENTS LOG FORMS (AF FORM 1924)	59.1	73.8	54.0	7.7	74.2	59.0	6.1					
E 214	UPDATE ROUTE CLEARANCE DATA	22.3	19.0	29.0	.0	18.1	27.4	3.0					

PERFORMING GENERAL AIR TRAFFIC CONTROL FUNCTIONS

F 215	ACTIVATE BACKUP COMMUNICATION SYSTEMS	71.0	76.6	76.6	30.8	81.4	78.8	24.2					
F 216	ACTIVATE BACKUP ELECTRICAL POWER SYSTEMS	25.5	29.8	24.2	7.7	30.1	29.9	9.1					
F 217	ADJUST RADAR SCOPE	57.5	29.8	91.9	.0	32.1	92.2	3.0					
F 218	APPROVE AERIAL REFUELING OPERATIONS	5.0	1.6	8.1	.0	1.1	8.5	.0					
F 219	APPROVE OR DISAPPROVE CELESTIAL NAVIGATION FLIGHT PLANS	1.9	.4	3.6	.0	1.4	4.1	.0					
F 220	APPROVE OR DISAPPROVE ENROUTE ALTITUDE RESERVATIONS	9.9	2.0	17.3	.0	1.9	12.4	.0					
F 221	APPROVE OR DISAPPROVE PILOT REQUESTS FOR DEVIATIONS FROM ATC CLEARANCES	51.9	37.1	73.0	15.4	38.1	74.0	12.1					
F 222	APPROVE OR DISAPPROVE POWER TRANSFERS	19.8	25.0	18.1	.0	33.7	25.4	.0					
F 222	APPROVE OR DISAPPROVE REQUESTS FOR DEVIATIONS IN ENROUTE FLIGHTS	21.6	5.2	39.5	.0	5.2	38.8	.0					
F 224	ASSIGN FREQUENCIES TO AIRCRAFT	80.4	78.6	93.1	7.7	77.5	93.0	12.1					
F 225	ASSIGN TRANSPONDER MODES AND CODES	62.7	48.0	87.1	.0	46.8	88.2	6.1					
F 226	AUTHORIZE AIRCRAFT OPERATIONS IN WARNING OR RESTRICTED AREAS	15.8	5.6	27.4	23.1	5.8	25.0	27.3					
F 227	AUTHORIZE EXTRACTION ZONE OPERATIONS	4.8	5.2	2.4	30.8	4.9	2.1	39.4					
F 228	AUTHORIZE INSTRUMENT FLIGHT RULES (IFR) AIRCRAFT DEPARTURES	53.6	46.4	71.8	7.7	42.2	73.0	9.1					
F 229	AUTHORIZE NONAPPROACH CONTROL TOWER TO PROVIDE VISUAL SEPARATION BETWEEN ARRIVALS AND DEPARTURES	24.8	10.1	44.4	.0	11.2	46.2	3.0					
F 230	AUTHORIZE PARACHUTE OR AIRDROP OPERATIONS	14.2	12.9	15.3	61.5	13.4	16.5	51.5					
F 231	AUTHORIZE PILOT COMMUNICATION INTERRUPTIONS	40.9	34.7	54.8	7.7	37.0	54.8	6.1					
F 232	AUTHORIZE SPECIAL VISUAL FLIGHT RULES (VFR) OPERATIONS	53.6	49.2	67.7	7.7	48.2	70.7	6.1					
F 233	AUTHORIZE VFR AIRCRAFT TO CROSS JET ADVISORY AREAS	11.3	5.2	19.4	.0	7.4	17.5	.0					
F 234	AUTHORIZE VFR DEPARTURES	60.0	81.9	50.8	15.4	84.4	50.7	33.3					
F 235	AUTHORIZE VISUAL SEPARATIONS	65.0	61.7	79.0	23.1	63.8	77.3	21.2					
F 236	CALCULATE ENROUTE AIRCRAFT POSITION ESTIMATES	9.9	4.4	16.9	.0	3.0	15.0	.0					
F 237	CALCULATE LOWEST USEABLE FLIGHT LEVELS	14.2	3.6	25.8	7.7	2.7	29.1	6.1					
F 238	CHECK FIELD OPERATING CONDITIONS	39.3	51.2	35.5	15.4	60.0	42.5	42.4					
F 239	CLEAN WORK AREAS OR EQUIPMENT	93.6	95.2	96.0	92.3	95.9	96.3	87.9					
F 240	CONDUCT BRIEFINGS ON ATC OPERATION EQUIPMENT	37.2	43.1	39.1	.0	49.9	48.7	6.1					
F 241	CONDUCT BRIEFINGS ON ATC PROCEDURES	30.8	35.5	32.7	.0	43.6	43.3	12.1					
F 242	CONTROL AND SEPARATE AIR TRAFFIC USING OCEANIC PROCEDURES	2.3	1.6	2.4	.0	2.2	2.7	.0					
F 243	CONTROL AND SEPARATE ARRIVING AIRCRAFT USING PRECISION APPROACH RADAR (PAR)	39.5	6.9	77.4	.0	7.7	84.3	.0					
F 244	CONTROL EXTRACTION ZONE OPERATIONS	5.7	6.0	2.4	69.2	5.2	2.1	60.6					
F 245	CONTROL PRECAUTIONARY APPROACHES	29.9	31.5	35.1	.0	38.6	43.9	.0					
F 246	COORDINATE AIRCRAFT HANDOFFS	57.0	28.6	93.5	.0	30.1	93.2	6.1					
F 247	COORDINATE AND CONTROL PRIORITY MISSIONS	32.2	33.5	38.3	.0	33.7	42.1	.0					
F 248	COORDINATE AND CONTROL SPECIAL TACTICAL MISSIONS	19.1	17.7	24.2	15.4	20.3	27.4	21.2					

INVENTORY ORDER OF 272XD/D TASKS

THIS IS A REPORT IN INVENTORY ORDER OF 272XD/D TASKS AND THE SAMPLE, CONTROL TOWER, RADAR CONTROL, AND CCT 1ST ENLISTMENT AND 5-SKILL LEVEL GROUPS.

B9

D ISK	TITLES	TS		CT		RC		CCT		CT		RC		CCT	
		TEL (M)	TEL (K)	TEL (M)	TEL (K)	TEL (M)	TEL (K)	TEL (M)	TEL (K)	TEL (M)	TEL (K)	TEL (M)	TEL (K)	TEL (M)	TEL (K)
F 249	COORDINATE PROCEDURES FOR AIRSPACE CONTROL WITH OTHER AGENCIES OR FACILITIES	42.1	33.1	59.7	.0	28.2	59.0	3.0	.0	29.0	42.1	.0	18.1	59.4	.0
F 250	COORDINATE WITH OPERATIONS ON TERMINAL ATC FACILITIES	30.8	29.5	39.1	.0	12.9	55.0	.0	.0	21.4	59.4	.0	20.5	42.3	3.0
F 251	DIRECT AND VECTOR AIRCRAFT TO EXTERNAL STORE JETTISON AREA	34.0	16.1	63.5	.0	75.1	85.2	3.0	7.7	18.1	70.1	3.0	63.8	46.2	6.1
F 252	DIRECT AND VECTOR AIRCRAFT TO FUEL DUMPING AREAS	30.4	10.9	57.7	.0	4.9	4.3	6.1	7.7	71.0	32.2	3.0	77.0	67.0	6.1
F 253	DIRECT EMERGENCY AIRCRAFT TO ALTERNATE AIRPORTS	33.6	19.4	56.0	.0	6.5	8.9	5.6	.0	8.2	4.1	.0	28.5	67.2	6.1
F 254	EXTRACT INFORMATION FROM TRANSMITTED FLIGHT PLANS	74.9	75.8	85.9	.0	4.9	4.3	6.1	.0	4.9	2.5	.0	14.5	11.8	.0
F 255	FILE FLIGHT PROGRESS STRIPS	39.3	19.2	65.7	.0	9.6	2.0	19.4	.0	1.4	20.0	3.0	12.6	41.2	3.0
F 256	FORMULATE IFR CLEARANCES	48.3	61.7	46.8	.0	85.8	81.6	30.3	23.1	16.4	16.7	.0	16.4	16.7	.0
F 257	HOLD ARRIVING VFR AIRCRAFT AT VISUAL FIXES	4.1	5.6	3.2	.0	98.1	98.1	30.3	23.1	98.1	98.1	30.3	91.8	91.5	19.2
F 258	IDENTIFY FRAGGED AIRCRAFT	41.1	64.1	27.8	7.7	6.5	80.4	6.1	.0	81.1	22.9	6.1	47.1	96.5	12.1
F 259	INITIATE ANTIJACKING PROCEDURES	59.5	70.6	62.5	.0	44.1	63.5	6.1	.0	44.1	63.5	6.1	7.9	15.5	3.0
F 260	INITIATE EMERGENCY ASSISTANCE PROCEDURES	6.5	8.9	5.6	.0	3.0	11.7	7.7	7.7	81.1	22.9	6.1	47.1	96.5	12.1
F 261	INITIATE REQUEST FOR AIRFIELD WAIVERS	46.4	31.0	71.0	.0	4.9	2.5	6.1	.0	4.9	2.5	6.1	7.9	15.5	3.0
F 262	INITIATE SPECIAL CONTROL ACTIONS FOR SOVIET BLOC AIRCRAFT FLIGHTS	2.5	3.2	2.0	.0	14.5	11.8	.0	.0	14.5	11.8	.0	14.5	11.8	.0
F 263	INITIATE SPECIAL EMERGENCY HANDLING PROCEDURES FOR CODED CALL SIGNS	13.1	14.9	12.9	.0	1.4	20.0	3.0	.0	1.4	20.0	3.0	12.6	41.2	3.0
F 264	INITIATE TYPED APPROACHES	9.6	2.0	19.4	.0	85.8	81.6	30.3	.0	85.8	81.6	30.3	16.4	16.7	.0
F 265	ISSUE AIRCRAFT IN-FLIGHT FUEL DUMPING ADVISORIES	74.3	86.7	77.8	23.1	16.4	16.7	.0	23.1	16.4	16.7	.0	98.1	98.1	30.3
F 266	ISSUE AIRMEN ADVISORIES (AIRAD)	15.5	16.9	12.9	.0	98.1	98.1	30.3	23.1	98.1	98.1	30.3	91.8	91.5	19.2
F 267	ISSUE ALTITUDE SETTINGS	91.0	98.8	97.6	23.1	98.1	98.1	30.3	23.1	98.1	98.1	30.3	91.8	91.5	19.2
F 268	ISSUE BIRD FLIGHT ADVISORIES	83.7	94.8	90.7	.0	6.5	80.4	6.1	.0	6.5	80.4	6.1	47.1	96.5	12.1
F 269	ISSUE BIRD FLIGHT INSTRUCTIONS	41.8	11.7	78.6	.0	47.1	96.5	12.1	.0	47.1	96.5	12.1	7.9	15.5	3.0
F 270	ISSUE IFR HOLDING INSTRUCTIONS	45.1	79.0	21.8	7.7	81.1	22.9	6.1	7.7	81.1	22.9	6.1	47.1	96.5	12.1
F 271	ISSUE JET BLAST ADVISORIES	68.3	51.2	96.4	.0	44.1	63.5	6.1	.0	44.1	63.5	6.1	7.9	15.5	3.0
F 272	ISSUE MISSED APPROACH INSTRUCTIONS	47.4	43.1	51.3	.0	3.0	11.7	7.7	7.7	3.0	11.7	7.7	3.0	11.7	7.7
F 273	ISSUE OR TRANSMIT ENROUTE CLEARANCES USING INTERNATIONAL CIVIL AVIATION ORGANIZATION (ICAO) PROCEDURES	8.8	7.3	12.5	.0	3.0	11.7	7.7	7.7	3.0	11.7	7.7	3.0	11.7	7.7
F 274	ISSUE OR TRANSMIT ENROUTE CLEARANCES USING INTERNATIONAL CIVIL AVIATION ORGANIZATION (ICAO) PROCEDURES	8.8	7.3	12.5	.0	3.0	11.7	7.7	7.7	3.0	11.7	7.7	3.0	11.7	7.7
F 275	ISSUE OR TRANSMIT ENROUTE CLEARANCES USING HOST NATION AGREEMENT PROCEDURES	5.1	3.6	7.3	.0	98.4	85.1	7.7	.0	98.4	85.1	7.7	98.4	85.1	7.7
F 276	ISSUE MAKE TURBULENCE ADVISORIES	82.7	98.4	85.1	7.7	98.4	85.1	7.7	7.7	98.4	85.1	7.7	98.4	85.1	7.7
F 277	ISSUE MAKE TURBULENCE ADVISORIES	82.7	98.4	85.1	7.7	98.4	85.1	7.7	7.7	98.4	85.1	7.7	98.4	85.1	7.7
F 278	ISSUE MAKE WEATHER ADVISORIES	86.5	96.8	95.2	61.5	98.6	96.3	78.8	61.5	98.6	96.3	78.8	98.6	96.3	78.8
F 279	ISSUE WHEELS DOWN ADVISORIES	90.3	98.8	94.0	69.2	95.9	97.3	78.8	69.2	95.9	97.3	78.8	95.9	97.3	78.8
F 280	ISSUE WIND ADVISORIES	91.5	96.4	98.0	69.2	95.9	97.3	78.8	69.2	95.9	97.3	78.8	95.9	97.3	78.8
F 281	LOCATE AIRCRAFT POSITIONS USING NONRADAR PROCEDURES	49.2	47.6	61.7	7.7	46.0	63.9	30.3	7.7	46.0	63.9	30.3	46.0	63.9	30.3
F 282	MAKE TIME CHECKS	86.7	97.6	93.5	23.1	96.4	93.0	30.3	23.1	96.4	93.0	30.3	96.4	93.0	30.3
F 283	MAKE WEATHER OBSERVATIONS	43.0	79.0	12.5	76.9	82.5	14.8	78.8	76.9	82.5	14.8	78.8	82.5	14.8	78.8
F 284	MONITOR VOICE COMMUNICATIONS	47.1	59.2	44.4	7.7	63.0	50.1	39.4	7.7	63.0	50.1	39.4	63.0	50.1	39.4
F 285	NOTIFY AGENCIES OF RUNWAYS IN USE	75.9	95.2	71.0	7.7	95.9	71.1	18.2	7.7	95.9	71.1	18.2	95.9	71.1	18.2
F 286	OPERATE AUTOMATIC TERMINAL INFORMATION SERVICE (ATIS) VEHICLES	38.1	63.7	20.2	.0	58.1	18.6	3.0	.0	58.1	18.6	3.0	58.1	18.6	3.0
F 287	OPERATE COMMUNICATION MOTOR VEHICLES OTHER THAN IN-SERVICE VEHICLES	4.4	5.6	1.6	46.2	6.3	2.1	48.5	46.2	6.3	2.1	48.5	6.3	2.1	48.5
F 288	OPERATE GENERATORS	20.4	21.0	17.7	84.6	25.5	23.5	84.8	84.6	25.5	23.5	84.8	25.5	23.5	84.8

AD-A094 050

AIR FORCE OCCUPATIONAL MEASUREMENT CENTER RANDOLPH AFB TX F/G 5/9
AIR TRAFFIC CONTROL AND COMBAT CONTROL TEAM OPERATIONS, AFS 272--ETC(U)
DEC 80

UNCLASSIFIED

NL

2 of 2
AD
2024/10



END
DATE
FILMED
2-81
DTIC

THIS IS A REPORT IN INVENTORY ORDER OF 272XC/D TASKS USING TOTAL SAMPLE, CONTROL TOWER, RADAR CONTROL, AND CCT 1ST ENLISTMENT AND 5-SKILL LEVEL GROUPS.

B10

D TASK	TITLES	YS		CT		RC		CCT		CT		RC		CCT	
		IEL (H)	IEL (M)	IEL (H)	IEL (M)	IEL (H)	IEL (M)	IEL (H)	IEL (M)	50 (M)	50 (M)	50 (M)	50 (M)	(M)	(M)
F 299	OPERATE NAVAID EQUIPMENT MONITORS	48.1	48.4	57.3	15.4	43.3	61.7	12.1							
F 290	OPERATE VOICE RECORDERS	57.7	42.7	80.6	.0	44.4	82.1	.0							
F 291	OPERATE WEATHER RECEIVING EQUIPMENT	58.8	63.7	66.1	15.4	66.0	70.9	12.1							
F 292	PERFORM AIRBORNE RADAR BEACON CHECKS	23.2	3.6	48.0	7.7	2.2	52.8	6.1							
F 293	PERFORM INTERFACILITY COORDINATIONS	81.1	85.1	90.7	7.7	85.5	93.4	3.0							
F 294	PERFORM INTRA-FACILITY COORDINATIONS	77.9	80.2	89.5	.0	81.9	91.3	.0							
F 295	PERFORM OPERATIONAL CHECKS ON ATIS	28.3	44.4	19.4	.0	42.7	18.8	3.0							
F 296	PERFORM RUNWAY CHECKS	11.3	17.7	5.2	46.2	16.4	4.9	63.6							
F 297	PERFORM SAFETY CHECKS ON ELECTRICAL EQUIPMENT	9.0	9.3	10.5	.0	10.7	9.9	6.1							
F 298	PERFORM SECURITY CONTROL OF AIR TRAFFIC AND AIR NAVIGATION AIDS (SCATANA) PROCEDURES	25.7	32.7	25.0	.0	32.9	28.3	.0							
F 299	PERFORM STIMULATED CRASH, ALERT, OR DISASTER CONTROL EXERCISES	34.7	56.0	22.2	.0	62.7	20.2	3.0							
F 300	PERFORM WEAPONS PROFICIENCY TRAINING EXERCISES	3.7	1.6	2.4	61.5	3.0	1.6	63.6							
F 301	PREPARE PAYMENT VOUCHERS	3.2	.8	2.0	61.5	1.1	1.6	57.6							
F 302	PREPARE TRAVEL ORDERS	1.2	.4	.8	23.1	.8	1.4	27.3							
F 303	PREPARE VIDEO MAPS	1.6	.4	2.8	.0	.5	3.3	.0							
F 304	PROVIDE SPECIAL CONTROLS FOR AIR DEFENSE INTERCEPT MISSIONS	6.2	5.6	8.1	.0	6.8	8.7	.0							
F 305	PROVIDE SPECIAL HANDLING FOR AIRCRAFT NAVAID FLIGHT INSPECTIONS	41.6	46.0	48.0	.0	45.5	53.0	.0							
F 306	PROVIDE SPECIAL HANDLING FOR CODED AIRCRAFT OPERATIONS OR MANEUVERS	23.5	30.6	22.2	.0	24.7	20.4	.0							
F 307	PROVIDE SPECIAL HANDLING FOR VERY IMPORTANT PERSONS (VIP) TRAFFIC	47.6	54.4	52.4	.0	52.1	51.3	.0							
F 308	PROVIDE VFR RADAR TRAFFIC ADVISORIES TO AFFECTED AGENCIES	38.8	28.2	58.1	.0	28.2	57.9	.0							
F 309	RECEIVE OR RELAY ENROUTE AIR TRAFFIC MOVEMENT INFORMATION	39.1	27.4	57.7	7.7	27.1	53.6	6.1							
F 310	REGULATE FLOW OF TRAFFIC BETWEEN SECTORS OR FACILITIES	28.0	17.3	44.4	.0	18.4	48.5	.0							
F 311	RELAY AIRCRAFT ARRIVAL OR DEPARTURE TIMES	78.8	98.0	73.4	38.5	97.5	71.3	39.4							
F 312	RELAY AIRCRAFT EMERGENCY INSTRUCTION FILE INFORMATION	27.8	32.7	29.8	.0	32.1	37.5	.0							
F 313	RELAY AIRCRAFT MESSAGES TO OTHER AGENCIES	77.5	87.1	82.3	38.5	84.9	80.0	27.3							
F 314	RELAY AIRCRAFT MOVEMENT INFORMATION	60.9	71.0	63.3	15.4	74.5	66.4	18.2							
F 315	RELAY COMMUNICATION INSTRUCTIONS FOR REPORTS OF VITAL INTELLIGENCE SIGHTINGS (CIRVIS) REPORTS	12.7	16.5	12.1	.0	20.0	13.8	.0							
F 316	RELAY IFR CLEARANCES	76.5	87.1	81.0	.0	85.8	83.7	9.1							
F 317	RELAY INFORMATION FOR ISSUANCE OR CANCELLATION OF NOTICE TO AIRMEN (NOTAMS)	52.4	65.7	51.6	.0	68.2	56.5	3.0							
F 318	RELAY INFORMATION FROM FLIGHT INFORMATION PUBLICATION (FLIP)	38.1	45.6	40.3	.0	47.4	45.0	3.0							
F 319	RELAY INFORMATION FROM RUNWAY VISUAL RANGE (RVR) READINGS	70.1	80.6	75.4	.0	80.5	74.6	.0							
F 320	RELAY HEADING, INTRUSION, AND JAMMING INTRUSION (MIJI) INFORMATION	41.1	47.6	44.8	7.7	50.7	46.0	3.0							
F 321	RELAY NOTICES OF OVERDUE AIRCRAFT	49.4	61.3	48.4	7.7	60.8	48.3	6.1							
F 322	RELAY NOTIFICATIONS OF GROUND MISSILE EMERGENCIES	3.2	4.8	2.4	.0	4.4	3.5	.0							
F 323	RELEASE ARRIVING OR DEPARTING AIRCRAFT TO OTHER FACILITIES	60.2	57.3	75.4	.0	55.3	74.0	6.1							
F 324	REMOVE OR REPLACE TELETYPEWRITER PAPER	80.7	88.3	87.1	7.7	90.7	86.8	3.0							

INVENTORY ORDER OF 272X0/D TASKS

THIS IS A REPORT IN INVENTORY ORDER OF 272X0/D TASKS USING TOTAL SAMPLE, CONTROL TOWER, RADAR CONTROL, AND CCT 1ST ENLISTMENT AND 5-SKILL LEVEL GROUPS.

D	TASK	TITLE	TS		CT		RC		CCT		CT		RC		CCT		
			IEL	(M)	IEL	(M)	IEL	(M)	IEL	(M)	IEL	(M)	IEL	(M)	IEL	(M)	IEL
F	325	REPLACE VOICE RECORDER TAPES	62.7	46.8	87.1							46.0	86.6				
F	326	REQUEST AIRCRAFT ALTITUDE VERIFICATIONS	63.9	41.5	96.8							36.4	95.3			9.1	
F	327	REQUEST AIRCRAFT POSITION INFORMATION	77.5	81.0	89.9	7.7						77.8	89.9			30.3	
F	328	REQUEST COMMISSIONING FLIGHT CHECKS	3.9	2.0	6.0							1.6	5.2				
F	329	REROUTE AIRCRAFT AROUND MILITARY OPERATIONAL AREAS	24.8	11.7	44.0							9.9	42.9				
F	330	SEPARATE AIRCRAFT USING WAKE TURBULENCE PROCEDURES	75.9	90.3	79.4	7.7						91.0	83.3			18.2	
F	331	UPDATE FLIGHT DATA ON FLIGHT DATA ENTRY PRINTOUT (FDEP)	36.5	32.7	44.8							29.0	41.7				

G	PERFORMING RADAR FUNCTIONS																

G	332	ADJUST MAP OVERLAYS	7.1	1.2	14.1							.8	15.0			3.0	
G	333	ADJUST VIDEO MAPS	21.1	9.7	35.5							9.6	39.6			3.0	
G	334	APPROVE OR DISAPPROVE CLE RANGES FOR PILOT'S REQUESTS TO CONDUCT UNUSUAL MANEUVERS	57.5	49.2	79.4	7.7						53.7	76.7			15.2	
G	335	APPROVE OR DISAPPROVE PILOT'S REQUESTS TO EXCEED SPEED LIMITS	31.3	27.4	43.1							30.1	43.7			6.1	
G	336	COORDINATE AIRCRAFT MOVEMENT AND IDENTIFICATION INFORMATION WITH AIR DEFENSE COMMAND (ADC)	4.8	3.6	6.5							5.2	7.6				
G	337	COORDINATE AIRCRAFT POSITION WITH TOWER OR RUNWAY SUPERVISORY UNITS (RSU)	38.6	18.5	66.1							20.0	61.6				
G	338	COORDINATE SEARCH AND RESCUE OPERATIONS	9.6	6.9	13.3	7.7						7.4	17.3				
G	339	ESTABLISH APPROACH SEQUENCES	51.3	28.2	84.3							27.7	83.1			9.1	
G	340	FORWARD AIRPORT LIGHTING REQUESTS TO CONTROL TOWERS	34.3	2.8	73.4							2.2	74.2				
G	341	IDENTIFY AIRCRAFT USING PRIMARY RADAR METHODS	49.4	8.9	96.8							8.8	96.1				
G	342	IDENTIFY AIRCRAFT USING TRANSPONDER METHODS	47.3	3.6	97.6							2.5	96.3				
G	343	INFORM AGENCIES OF OBSERVED UNUSUAL EVENTS OR INCIDENTS	43.5	40.7	57.3							43.0	57.9			6.1	
G	344	INFORM AIRCRAFT OF RADAR IDENTIFICATION STATUS	39.1	.4	83.9							1.6	84.3				
G	345	INFORM AIRCRAFT OF RADAR TERMINATIONS	40.5	1.2	87.1							2.2	87.2				
G	346	INITIATE SPECIAL RADAR ACTIONS DURING ELECTRONIC COUNTER-MEASURE (ECM) ACTIVITIES	9.9	.4	21.4							1.6	25.0				
G	347	INTERPRET RADAR BEACON DISPLAYS	31.5	2.8	67.7							3.8	69.1				
G	348	ISSUE ADVANCE APPROACH INFORMATION TO ARRIVING AIRCRAFT	40.2	9.3	80.6							10.7	81.4				
G	349	ISSUE AIRCRAFT SPEED ADJUSTMENTS	45.3	9.7	90.3							11.5	90.3			3.0	
G	350	ISSUE ALTERNATE CLEARANCES	39.8	12.9	75.0							11.5	75.3				
G	351	ISSUE DECISION HEIGHT ALTITUDE ADVISORIES	43.2	3.6	88.7							4.9	90.7				
G	352	ISSUE LOST COMMUNICATIONS INSTRUCTIONS	43.2	2.0	91.1							1.9	92.0				
G	353	ISSUE MINIMUM DESCENT ALTITUDE ADVISORIES	43.7	3.6	89.9							4.4	91.3				
G	354	MARK DECISION HEIGHT LINES ON RADAR INDICATORS	39.3	2.8	80.2							3.8	85.0				
G	355	MONITOR AIRCRAFT DEPARTURES ON RADAR	43.4	9.7	84.7							10.7	84.5				
G	356	OPERATE RADAR SIMULATORS	24.2	1.6	45.6							1.6	43.9				
G	357	OPERATIONALLY CHECK AND ADJUST EQUIPMENT ALIGNMENT VOLTAGES	34.2	2.4	71.4							2.2	75.0				
G	358	OPERATIONALLY CHECK PRIMARY RADAR	39.3	1.2	86.3							1.9	89.9				
G	359	OPERATIONALLY CHECK RADAR ANTENNA TILT METERS	9.4	.0	20.6							.3	20.2				

THIS IS A REPORT IN INVENTORY ORDER OF 272X3/D TASKS USING TOTAL SAMPLE,
CONTROL TOWER, RADAR CONTROL, AND CCT 1ST ENLISTMENT AND S-SKILL LEVEL GROUPS.

D LSK	TITLES	IS (M)	CT (M)	RC TEL (M)	CCT TEL (M)	CT SO (M)	RC SO (M)	CCT SO (M)
G 360	OPERATIONALLY CHECK RADAR DISPLAYS OF TOUCHDOWN AND BRACKETING REFLECTORS	37.7	1.2	79.8	.0	1.9	84.5	.0
G 361	OPERATIONALLY CHECK REMOTE LINE AMPLIFIERS (RLA)	23.9	1.2	51.2	.0	1.6	54.4	.0
G 362	OPERATIONALLY CHECK SECONDARY RADARS	35.9	.4	79.4	.0	.8	84.3	.0
G 363	PERFORM RADAR EQUIPMENT TURN AROUND PROCEDURES	31.9	3.2	64.5	.0	3.3	68.2	.0
G 364	PERFORM RADAR HANDOFFS	46.9	2.4	95.6	.0	2.2	94.0	.0
G 365	PROVIDE PRECISION RADAR APPROACHES	43.9	2.8	88.7	.0	3.3	92.4	.0
G 366	PROVIDE RADAR ADVISORIES TO VFR AIRCRAFT	45.0	11.7	86.3	.0	11.8	84.3	.0
G 367	PROVIDE RADAR ASSISTANCE TO EMERGENCY AIRCRAFT	39.1	.8	84.3	.0	1.4	91.8	.0
G 368	PROVIDE RADAR MONITORING OF INSTRUMENT APPROACHES	39.6	2.4	81.5	.0	2.2	83.9	.0
G 369	PROVIDE RADAR SURVEILLANCE APPROACHES	41.9	1.2	88.3	.0	1.1	91.8	.0
G 370	PROVIDE RADAR WEATHER OBSERVATIONS TO AIR WEATHER SERVICE (AWS)	9.2	2.4	17.7	.0	4.4	22.5	.0
G 371	PROVIDE STAGE I, II, OR III RADAR SERVICES	43.7	17.3	78.6	.0	15.3	79.6	.0
G 372	REPORT RADAR MALFUNCTIONS	45.3	6.9	91.1	.0	10.1	94.6	.0
G 373	REQUEST AND RELAY CLEARANCES FOR LANDING USING LIGHT VOICE METHODS	37.5	18.1	64.5	.0	20.8	70.7	.0
G 374	SELECT RADAR BEACON PRESENTATIONS	33.5	.4	74.2	.0	.5	74.4	.0
G 375	TRACK OR FLIGHT-FOLLOW UNMANNED OR DERELICT AIRBORNE OBJECTS	5.1	.8	10.9	.0	.8	13.4	.0

H PERFORMING CONTROL TOWER FUNCTIONS

H 376	ACTIVATE EMERGENCY EVACUATION ALARM SYSTEMS	46.4	91.5	12.1	7.7	93.7	11.8	.0
H 377	ADJUST BRITE II RADAR SYSTEMS	44.8	85.3	13.7	7.7	84.9	11.7	3.0
H 378	ADVISE PILOTS OF OBSERVED ABNORMAL AIRCRAFT CONDITIONS	54.5	89.9	31.9	7.7	91.8	29.3	15.2
H 379	APPROVE OR DISAPPROVE AIRCRAFT MAINTENANCE ENGINE RUNUPS	43.5	86.3	10.9	7.7	83.8	11.3	3.0
H 380	APPROVE OR DISAPPROVE AIRCRAFT TAXIING	48.3	96.0	11.3	23.1	96.2	12.0	33.3
H 381	APPROVE OR DISAPPROVE CLEARANCES FOR AIRCRAFT OR VEHICLE OPERATION IN ILS CRITICAL AREAS	24.8	45.6	9.3	.0	43.6	7.6	3.0
H 382	APPROVE OR DISAPPROVE TAKEOFFS	53.3	94.4	23.8	23.1	94.8	22.7	45.5
H 383	APPROVE OR DISAPPROVE TOWING OPERATIONS	39.8	79.0	9.7	7.7	76.7	10.5	3.0
H 384	ASSIGN RUNWAYS FOR LANDINGS OR TAKEOFFS	44.6	80.6	16.5	30.8	84.4	15.5	39.4
H 385	AUTHORIZE INTERSECTION TAKEOFFS	45.7	93.1	11.3	7.7	95.3	11.8	12.1
H 386	AUTHORIZE SIMULTANEOUS OPPOSITE DIRECTION OPERATIONS	27.3	44.8	15.7	7.7	49.0	16.3	.0
H 387	AUTHORIZE SIMULTANEOUS SAME DIRECTION OPERATIONS	34.7	60.1	17.3	7.7	65.2	17.7	3.0
H 388	CLEAR MOVEMENT AREA FOR EMERGENCY VEHICLE OPERATIONS	40.2	78.6	10.9	15.4	81.4	11.3	18.2
H 389	CONTROL AIRCRAFT USING LIGHT GUN SIGNALS	48.1	94.8	11.3	30.8	95.6	11.8	45.5
H 390	CONTROL AIRCRAFT USING LIGHT GUN SIGNALS	19.5	36.7	6.5	.0	38.6	7.4	3.0
H 391	CONTROL VEHICLES, EQUIPMENT, OR PERSONNEL IN MOVEMENT AREA USING LIGHT GUN SIGNALS	41.9	81.9	10.5	30.8	80.8	11.1	48.5
H 392	CONTROL VEHICLES, EQUIPMENT, OR PERSONNEL IN MOVEMENT AREA USING RADIOS	46.5	91.1	11.3	38.5	91.8	11.8	42.4
H 393	GIVE CLEARANCES OR NONCLEARANCES FOR ARRIVING AIRCRAFT	45.0	71.4	28.2	7.7	74.2	28.3	27.3
H 395	INITIATE DEPARTURE CONTROL OVERRIDE PROCEDURES	32.0	60.5	10.5	7.7	61.6	11.1	3.0

THIS IS A REPORT IN INVENTORY ORDER OF 272X0/D TASKS USING 10-TAL SAMPLE, CONTROL TOWER, RADAR CONTROL, AND CCT 1ST ENLISTMENT AND 5-SKILL LEVEL GROUPS.

D. ISK	TITLES	TS		RC		CCT		CT		RC		CCT	
		1EL (M)	1EL (M)	1EL (M)	1EL (M)	1EL (M)	1EL (M)	1EL (M)	1EL (M)	1EL (M)	1EL (M)	1EL (M)	1EL (M)
H 395	ISSUE TAXING INSTRUCTIONS	49.0	97.6	11.3	15.4	97.8	12.2	39.4					
H 396	MAINTAIN SURVEILLANCE OF AIRPORT MOVEMENT AND TRAFFIC AREAS	47.3	95.5	11.3	23.1	95.3	12.0	30.3					
H 397	OPERATE AIRCRAFT ARRESTING SYSTEMS	11.2	21.4	3.2	.0	25.2	4.1	.0					
H 398	OPERATE AIRFIELD APPROACH LIGHTING SYSTEMS	47.8	95.2	11.3	7.7	94.8	11.8	18.2					
H 399	OPERATE PRIMARY CRASH ALARM SYSTEMS	48.7	96.8	11.3	7.7	98.6	12.0	6.1					
H 400	OPERATE ROTATING BEACONS	44.2	87.1	10.1	30.8	87.4	10.3	36.4					
H 401	OPERATE VEHICLE TRAFFIC CONTROL VISUAL SIGNALS	20.4	40.3	4.8	.0	43.6	6.6	9.1					
H 402	PLOT POSITIONS ON CRASH GRID MAPS	39.8	77.8	11.3	7.7	83.3	11.3	3.0					
H 403	REQUEST AIRCRAFT RELEASES FROM DEPARTURE CONTROL	49.6	96.4	13.3	15.4	95.9	12.8	6.1					
H 404	SELECT APPROPRIATE WIND SENSORS	36.6	71.4	10.5	.0	75.3	11.3	6.1					
H 405	SEQUENCE DEPARTING AIRCRAFT	49.4	89.5	19.4	30.8	91.2	19.8	36.4					
H 406	SEQUENCE LANDING AIRCRAFT	58.9	97.6	32.7	30.8	97.0	30.3	42.4					
H 407	SUPPORT MINIMUM INTERVAL TAKEOFF OPERATIONS (MITO)	28.8	52.0	13.3	.0	50.7	13.6	6.1					

I PERFORMING AIR TRAFFIC REGULATIONS CENTER (AIRC) FUNCTIONS

I 408	ADVISE AIRSPACE CONTROL CENTER (ACC) BRANCHES OF CHANGES TO OPERATING PROCEDURES	1.4	.8	1.2	.0	1.1	.9	.0					
I 409	ADVISE TACTICAL AIR CONTROL CENTERS (TACC) OF CHANGES TO OPERATING PROCEDURES	.7	.8	.4	.0	.6	.2	.0					
I 410	CONDUCT ATRC MISSION BRIEFINGS	.2	.0	.4	.0	.0	.2	.0					
I 411	CONDUCT ATRC MISSION DEBRIEFINGS	.4	.0	.4	.0	.0	.2	.0					
I 412	COORDINATE AIRSPACE UTILIZATIONS WITH CONTROL AGENCIES	3.5	2.4	4.8	.0	1.6	2.5	.0					
I 413	COORDINATE CONTROLLER MANNING REQUIREMENTS WITH SENIOR DIRECTOR OF OPERATIONS	.2	.0	.4	.0	.0	.4	.0					
I 414	COORDINATE FLIGHT PLAN DATA WITH MOVEMENTS AND IDENTIFICATION SECTIONS	1.1	.0	1.2	7.7	.5	1.2	3.0					
I 415	ERECT OR TEAR DOWN TACTICAL AIR CONTROL SYSTEM (TACS) FACILITIES	.2	.0	.4	.0	.0	.2	.0					
I 416	INTERPRET FRAG ORDERS	.2	.0	.4	.0	.3	.2	3.0					
I 417	ISSUE TACC GUIDANCE TO CONTROLLER ON USE OF AIRSPACE OR CONTROL PROCEDURES	.4	.0	.4	.0	.0	.2	.0					
I 418	OPERATE 497L TACS	.4	.0	.4	.0	.0	.4	.0					
I 419	OPERATE 485L TACTICAL AIR DEFENSE SYSTEMS (TADS)	.4	.0	.4	.0	.5	.4	.0					
I 420	POSITION MOBILE SUPPORT EQUIPMENT	.5	.0	.4	7.7	.0	.4	3.0					
I 421	POSITION MOBILE TACS EQUIPMENT	.4	.0	.4	.0	.0	.4	.0					
I 422	PREPARE ATRC EQUIPMENT CHECK LISTS	.4	.0	.4	.0	.0	.4	.0					
I 423	PROVIDE MONITOR SERVICE FOR OVER FLIGHTS IN ASSIGNED AREAS OF CONTROLLED RESPONSIBILITY	3.4	1.6	5.2	.0	1.6	3.9	.0					
I 424	PROVIDE NONRADAR SEPARATIONS IN ENROUTE ENVIRONMENTS	2.3	.4	3.6	7.7	.3	3.5	6.1					
I 425	PROVIDE RAJAR SEPARATIONS IN ENROUTE ENVIRONMENTS	2.5	.0	4.8	.0	.0	4.1	.0					
I 426	RECORD AND DEPICT HOSTILE FIRE LOCATIONS	.7	.4	.4	7.7	.3	.4	9.1					

INVENTORY ORDER OF 272X0/D TASKS

THIS IS A REPORT IN INVENTORY ORDER OF 272X0/D TASKS USING TOTAL SAMPLE, CONTROL TOWER, RADAR CONTROL, AND CCT 1ST ENLISTMENT AND 5-SKILL LEVEL GROUPS.

D	TASK	IILES		CCT		RC		CT		RC		CCT		
		TEL (M)	CT (M)	TEL (M)	CT (M)	TEL (M)	CT (M)	TEL (M)	CT (M)	TEL (M)	CT (M)	TEL (M)	CT (M)	
I	427	.7	.4	.4	.4	7.7	.5	.4	.4	.4	.4	.4	15.2	
I	428	.4	.0	.4	.4	.0	.3	.4	.4	.4	.4	.4	.0	
I	429	.4	.0	.4	.4	.0	.3	.4	.4	.4	.4	.4	.0	
I	430	.5	.0	.8	.8	.0	.5	.6	.5	.5	.6	.6	.0	
J	PERFORMING MOBILE OPERATIONS													
J	431	.5	.0	.4	.4	.0	.5	.4	.4	.4	.4	.4	15.2	
J	432	.4	.0	.4	.4	.0	.5	.4	.4	.4	.4	.4	15.2	
J	433	.5	.0	.4	.4	.0	.8	1.2	.8	.8	1.2	.8	.0	
J	434	.4	.0	.4	.4	.0	.5	.4	.4	.4	.4	.4	3.0	
J	435	.4	.0	.4	.4	.0	1.1	.6	1.1	1.1	.6	.6	9.1	
J	436	.5	.4	.4	.4	.0	.5	.4	.4	.4	.4	.4	12.1	
J	437	.4	.0	.4	.4	.0	.5	.4	.4	.4	.4	.4	.0	
J	438	.4	.0	.4	.4	.0	.5	.4	.4	.4	.4	.4	6.1	
J	439	1.4	.4	1.2	1.1	7.7	1.1	2.1	1.1	2.1	1.7	1.7	15.2	
J	440	.9	.4	.8	.8	.0	.3	.6	.3	.6	.6	.6	6.1	
J	441	.4	.0	.4	.4	.0	.3	.6	.3	.6	.6	.6	15.2	
J	442	.4	.0	.4	.4	.0	.3	.6	.3	.6	.6	.6	.0	
J	443	.7	.0	.8	.8	.0	.8	1.7	.8	1.7	1.7	.8	.0	
J	444	.4	.0	.4	.4	.0	1.1	1.0	1.1	1.0	1.0	1.0	.0	
J	445	1.9	.0	.4	.4	38.5	1.1	1.4	1.1	1.4	1.4	1.4	51.5	
J	446	2.5	.0	.6	.6	53.6	1.1	2.1	1.1	2.1	2.1	2.1	67.7	
J	447	1.6	.0	.4	.4	38.5	.8	1.6	.8	1.6	1.6	1.6	54.5	
J	448	1.1	.8	.8	.8	7.7	1.1	1.2	1.1	1.2	1.2	1.2	15.2	
J	449	.7	.0	.4	.4	15.4	.5	1.0	.5	1.0	1.0	1.0	30.3	
J	450	1.4	.4	.8	.8	15.4	.8	1.7	.8	1.7	1.7	1.7	18.2	
J	451	.2	.0	.4	.4	.0	.3	.4	.3	.4	.4	.4	3.0	
J	452	1.4	.0	1.2	1.1	23.1	1.1	1.7	1.1	1.7	1.7	1.7	24.2	
J	453	.9	.4	.8	.8	15.4	.8	1.4	.8	1.4	1.4	1.4	15.2	
J	454	.4	.0	.4	.4	.0	.5	1.0	.5	1.0	1.0	1.0	3.0	
J	455	.2	.0	.4	.4	.0	.3	.4	.3	.4	.4	.4	.0	
J	456	.9	.4	1.2	1.1	7.7	.5	.4	.5	.4	.4	.4	15.2	
J	457	.4	.0	.4	.4	.0	.3	.4	.3	.4	.4	.4	.0	
J	458	.5	.0	.4	.4	7.7	.0	.2	.0	.2	.2	.2	9.1	
J	459	1.1	.0	.4	.4	30.8	.5	1.2	.5	1.2	1.2	1.2	51.5	
J	460	1.2	.0	.4	.4	38.5	.3	.6	.3	.6	.6	.6	39.4	

B15

D	TASK	TITLES	TS		CT		RC		CCT		CT		RC		CCT		
			DEL	(M)	DEL	(M)	DEL	(M)	DEL	(M)	DEL	(M)	DEL	(M)	DEL	(M)	DEL
K PERFORMING COMBAT CONTROL OPERATIONS AND TRAINING																	
K	461	CONDUCT ASSAULT ZONE CONTROL OFFICER TRAINING	.5	.0	.4	.4	7.7	.3	.2	18.2	.3	.2	.2	48.5	.4	60.6	
K	462	CONDUCT ASSAULT ZONE SURVEYS	1.6	.0	.4	.4	53.8	.0	.2	93.9	.3	.4	.2	48.5	.4	60.6	
K	463	CONDUCT COMBAT CONTROL PHASE III CONTINUATION TRAINING (CCT)	1.8	.0	.4	.4	53.8	.3	.4	39.4	.3	.4	.2	27.3	.4	93.9	
K	464	CONDUCT COMBAT CONTROL UPGRADE TRAINING	1.1	.0	.4	.4	23.1	.3	.4	48.5	.3	.4	.2	48.5	.4	60.6	
K	465	CONDUCT DROP ZONE CONTROL OFFICER TRAINING	.7	.0	.4	.4	15.4	.0	.2	27.3	.3	.4	.2	48.5	.4	60.6	
K	466	CONDUCT JUMP MASTER INSPECTIONS	2.7	.0	.8	.8	92.3	.3	.4	93.9	.3	.4	.2	48.5	.4	60.6	
K	467	CONDUCT JUMP MASTER TRAINING	1.6	.0	.4	.4	53.8	.3	.4	39.4	.3	.4	.2	27.3	.4	93.9	
K	468	CONDUCT SITE EVACUATION SURVEYS	.4	.0	.4	.4	.0	.0	.2	48.5	.3	.4	.2	48.5	.4	60.6	
K	469	CONDUCT SPECIAL OPERATION PROCEDURES TRAINING	.5	.0	.4	.4	7.7	.3	.4	18.2	.3	.4	.2	48.5	.4	60.6	
K	470	CONDUCT COMMUNICATION EQUIPMENT FOR AIR-LAND EMPLOYMENTS	2.1	.0	.4	.4	76.9	.5	.2	75.8	.5	.2	.2	48.5	.4	60.6	
K	471	CONDUCT COMMUNICATION EQUIPMENT FOR PARACHUTE EMPLOYMENTS	2.5	.0	.4	.4	92.3	.5	.2	87.9	.5	.2	.2	48.5	.4	60.6	
K	472	CONFIGURE COMMUNICATION EQUIPMENT FOR SELF CONTAINED UNDERWATER BREATHING APPARATUS (SCUBA) EMPLOYMENTS	.5	.0	.4	.4	7.7	.3	.2	9.1	.3	.2	.2	48.5	.4	60.6	
K	473	CONFIGURE FIELD GEAR FOR AIR-LAND EMPLOYMENTS	2.7	.0	.4	.4	100.0	.5	.2	93.9	.5	.2	.2	48.5	.4	60.6	
K	474	CONFIGURE FIELD GEAR FOR PARACHUTE EMPLOYMENTS	2.3	.0	.4	.4	84.6	.5	.2	90.9	.5	.2	.2	48.5	.4	60.6	
K	475	CONFIGURE FIELD GEAR FOR SCUBA EMPLOYMENTS	.5	.0	.4	.4	7.7	.5	.2	9.1	.5	.2	.2	48.5	.4	60.6	
K	476	CONFIGURE SUPPORT EQUIPMENT FOR ADMINISTRATION OPERATIONS	1.8	.0	.4	.4	61.5	.8	.2	54.5	.8	.2	.2	48.5	.4	60.6	
K	477	CONTROL ASSAULT ZONE OPERATIONS	2.5	.4	.4	.4	92.3	1.6	.4	90.9	1.6	.4	.4	90.9	.4	90.9	
K	478	DETERMINE ASSAULT ZONE LOCATIONS	.9	.0	.4	.4	30.8	.5	.2	42.8	.5	.2	.2	48.5	.4	60.6	
K	479	ERECT OR TEAR-DOWN AN/THC-22 PORTABLE WEATHER STATIONS	1.8	.0	.4	.4	69.2	.3	.2	63.6	.3	.2	.2	48.5	.4	60.6	
K	480	INSPECT PARACHUTES	2.5	.0	.4	.4	100.0	.3	.4	100.0	.3	.4	.4	100.0	.4	100.0	
K	481	INSTALL OR REPLACE NAVOID EQUIPMENT AT ASSAULT ZONES	2.1	.0	.4	.4	76.9	.0	.2	78.8	.0	.2	.2	48.5	.4	60.6	
K	482	INSTALL OR REPLACE PORTABLE COMMUNICATION EQUIPMENT AT ASSAULT ZONES	2.5	.0	.4	.4	92.3	.5	.2	84.8	.5	.2	.2	48.5	.4	60.6	
K	483	MARK ASSAULT ZONES	2.7	.0	.4	.4	100.0	.8	.2	97.0	.8	.2	.2	48.5	.4	60.6	
K	484	OPERATE PORTABLE COMMUNICATION EQUIPMENT	3.0	.8	.4	.4	100.0	1.9	.8	97.0	1.9	.8	.2	48.5	.4	60.6	
K	485	OPERATE PORTABLE NAVOID EQUIPMENT	2.5	.4	.4	.4	84.6	.5	.4	87.9	.5	.4	.4	87.9	.4	87.9	
K	486	PACK PARACHUTES	2.7	.0	.4	.4	100.0	.5	.2	100.0	.5	.2	.2	48.5	.4	60.6	
K	487	PERFORM AEROMEDICAL EVACUATION SUPPORT PROCEDURES	.5	.4	.4	.4	.0	.5	.2	15.2	.5	.2	.2	48.5	.4	60.6	
K	488	PERFORM AIR RECONNAISSANCE IN SUPPORT PROCEDURES	.4	.0	.4	.4	.0	.3	.2	9.1	.3	.2	.2	48.5	.4	60.6	
K	489	PERFORM ARCTIC OPERATIONS	.5	.0	.4	.4	15.4	.3	.2	36.8	.3	.2	.2	48.5	.4	60.6	
K	490	PERFORM COMBAT CONTROL STANDARDIZATION AND EVALUATION CHECKS	.7	.0	.4	.4	23.1	.3	.2	39.4	.3	.2	.2	48.5	.4	60.6	
K	491	PERFORM COMBAT CONTROL TEAM AMPHIBIOUS OPERATIONS	1.4	.0	.4	.4	53.8	.5	.2	49.5	.5	.2	.2	48.5	.4	60.6	
K	492	PERFORM COMBAT CONTROL TEAM ARTILLERY FLIGHTING FUNCTIONS	1.2	.0	.4	.4	46.2	.3	.2	42.8	.3	.2	.2	48.5	.4	60.6	
K	493	PERFORM COMBAT CONTROL TEAM ASSIGNED WEAPON TRAINING	2.7	.0	.4	.4	100.0	.8	.2	97.0	.8	.2	.2	48.5	.4	60.6	
K	494	PERFORM COMBAT CONTROL TEAM DEMOLITION OPERATIONS	2.5	.0	.4	.4	100.0	.6	.2	100.0	.6	.2	.2	48.5	.4	60.6	
K	495	PERFORM COMBAT CONTROL TEAM REPELLING TECHNIQUES	2.8	.0	.4	.4	100.0	.5	.2	97.0	.5	.2	.2	48.5	.4	60.6	
K	496	PERFORM COMBAT CONTROL TEAM UNIT TACTICS OPERATIONS	1.9	.0	.4	.4	76.9	.3	.2	90.9	.3	.2	.2	48.5	.4	60.6	
K	497	PERFORM COMBAT CONTROL TRAINING MISSIONS	2.1	.0	.4	.4	84.6	.3	.4	90.9	.3	.4	.4	90.9	.4	90.9	
K	498	PERFORM CONVENTIONAL APPROACH CONTROL PROCEDURES	2.1	.4	.4	.4	38.5	.3	1.9	48.5	.3	1.9	.4	48.5	.4	48.5	
K	499	PERFORM DESERT OPERATIONS	.7	.0	.4	.4	23.1	.3	.2	24.2	.3	.2	.2	48.5	.4	60.6	
K	500	PERFORM ESCAPE AND EVASION TECHNIQUES	1.9	.0	.4	.4	76.9	.5	.2	75.8	.5	.2	.2	48.5	.4	60.6	
K	501	PERFORM HIGH ALTITUDE LOW OPENING (HALO) OPERATIONS	1.4	.0	.4	.4	46.2	.3	.2	30.3	.3	.2	.2	48.5	.4	60.6	
K	502	PERFORM JUNGLE OPERATIONS	1.6	.0	.4	.4	46.2	.3	.2	36.8	.3	.2	.2	48.5	.4	60.6	
K	503	PERFORM LAND NAVIGATION PROFICIENCY TRAINING	2.3	.0	.4	.4	76.9	.3	.2	84.8	.3	.2	.2	48.5	.4	60.6	

D	TASK	TITLES	YS (M)	CT (M)	RC (M)	CCT (M)	CT (M)	RC (M)	SO (M)	CCT (M)
K	504	PERFORM LIMITED INTELLIGENCE FUNCTIONS IN SUPPORT AIR OPERATIONS	1.2	.4	.4	30.8	.3	.2	.2	33.3
K	505	PERFORM MOUNTAIN OPERATIONS	.7	.0	.4	15.4	.5	.2	.2	24.2
K	506	PERFORM OPERATOR MAINTENANCE ON COMMUNICATION EQUIPMENT	1.8	.0	.4	61.5	.8	.6	.6	72.7
K	507	PERFORM OPERATOR MAINTENANCE ON PARACHUTE EQUIPMENT	2.3	.0	.4	84.6	.3	.2	.2	90.9
K	508	PERFORM OPERATOR MAINTENANCE ON PORTABLE WEATHER MEASURING STATIONS, AN/TMO-22	.7	.0	.4	15.4	.5	.4	.4	27.3
K	509	PERFORM OPERATOR MAINTENANCE ON SCUBA EQUIPMENT	.7	.0	.4	7.7	.3	.2	.2	6.1
K	510	PERFORM OPERATOR MAINTENANCE ON WEAPON EQUIPMENT	2.7	.0	.4	92.3	.3	.2	.2	97.0
K	511	PERFORM SCUBA OPERATIONS	.5	.0	.4	7.7	.3	.4	.4	9.1
K	512	PERFORM SEMIANNUAL TACTICAL EMPLOYMENT TRAINING	2.3	.0	.4	76.9	.3	.2	.2	84.8
K	513	PERFORM STABO EXTRACTION OPERATIONS	1.6	.0	.4	53.8	.3	.2	.2	36.4
K	514	PERFORM STATIC LINE OPERATIONS	2.8	.0	.4	100.0	.5	.2	.2	97.0
K	515	PERFORM SURVIVAL TECHNIQUE PROFICIENCY TRAINING EXERCISES	1.6	.0	.4	53.8	.5	.2	.2	69.7
K	516	PERFORM TACTICAL AIRLIFT LIAISON OFFICER (TALO) TRAINING EXERCISES	.5	.0	.4	7.7	.0	.2	.2	12.1
K	517	PLAN AND COORDINATE COMBAT TRAINING MISSIONS	1.1	.0	.4	30.8	.3	.2	.2	51.5
K	518	RENDER COMBAT FIRST AID	1.8	.0	.4	53.8	.5	.6	.6	66.7

DATE
ILMED
—8