

AD-A094 690

DAVID W TAYLOR NAVAL SHIP RESEARCH AND DEVELOPMENT CE--ETC F/G 20/4
INVESTIGATIONS OF UNDERWATER FLOW PATTERNS FOR THREE TUNNEL-FIN--ETC(U)
FEB 81 S A HAMPTON

UNCLASSIFIED

DTNSRDC/SPD-0544-17

NL

1 of 1
AD
000000

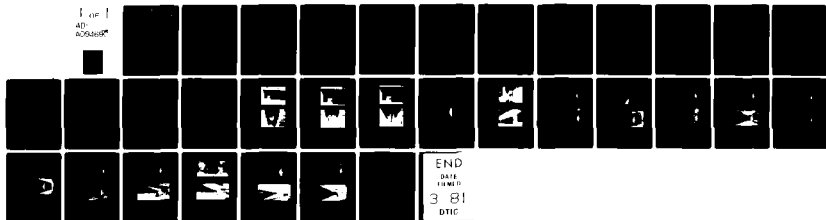

LEVEL

12

**DAVID W. TAYLOR NAVAL SHIP
RESEARCH AND DEVELOPMENT CENTER**



Bethesda, Maryland 20884

AD A094690

DTNSRDC/SPD-0544-17

DTNSRDC/SPD-0544-17

INVESTIGATIONS OF UNDERWATER FLOW PATTERNS FOR THREE TUNNEL-FIN
CONFIGURATIONS FOR THE NAVAL AUXILIARY OILER (AO 177) REPRESENTED BY MODEL 5326-1

INVESTIGATIONS OF UNDERWATER FLOW PATTERNS FOR
THREE TUNNEL-FIN CONFIGURATIONS FOR THE NAVAL
AUXILIARY OILER (AO 177) REPRESENTED BY MODEL 5326-1.

BY

GARY A. HAMPTON

Distribution Unlimited;
Approved for Public Release

DTIC
FEB 5 1981

SHIP PERFORMANCE DEPARTMENT REPORT

81 2 03 007

FEBRUARY 1981

DTNSRDC/SPD-0544-17

DBC FILE COPY

MAJOR DTNSRDC ORGANIZATIONAL COMPONENTS

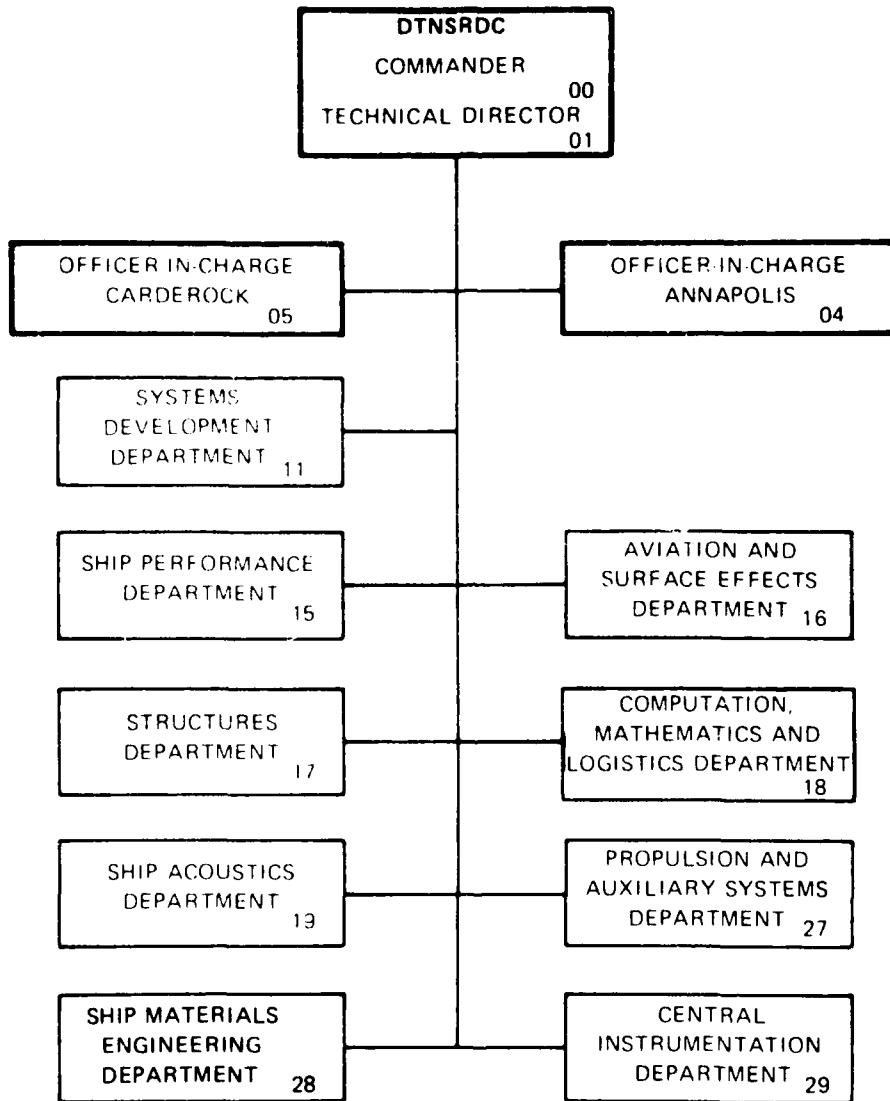

UNCLASSIFIED

SECURITY CLASSIFICATION OF THIS PAGE (When Data Entered)

REPORT DOCUMENTATION PAGE		READ INSTRUCTIONS BEFORE COMPLETING FORM
1 REPORT NUMBER DTNSRDC/SPD-0544-17 ✓	2 GOVT ACCESSION NO. AD-4094690	3 RECIPIENT'S CATALOG NUMBER
4 TITLE (and Subtitle) INVESTIGATIONS OF UNDERWATER FLOW PATTERNS FOR THREE TUNNEL-FIN CONFIGURATIONS FOR THE NAVAL AUXILIARY OILER (AO 177) REPRESENTED BY MODEL 5326-1		5 TYPE OF REPORT & PERIOD COVERED FINAL
7 AUTHOR GARY A. HAMPTON		6 PERFORMING ORG. REPORT NUMBER
9 PERFORMING ORGANIZATION NAME AND ADDRESS DAVID TAYLOR NAVAL SHIP R&D CENTER SHIP PERFORMANCE DEPARTMENT BETHESDA, MD 20084		8 CONTRACT OR GRANT NUMBER(s) POOR144, POOR146 1-1532-110, 1-1532-115
11 CONTROLLING OFFICE NAME AND ADDRESS NAVAL SEA SYSTEMS COMMAND WASHINGTON, D. C. 20362		10 PROGRAM ELEMENT, PROJECT, TASK AREA & WORK UNIT NUMBERS
14 MONITORING AGENCY NAME & ADDRESS (if different from Controlling Office)		12 REPORT DATE February 1981
		13 NUMBER OF PAGES 31
		15 SECURITY CLASS. (of this report) UNCLASSIFIED
		15a DECLASSIFICATION/DOWNGRADING SCHEDULE
16 DISTRIBUTION STATEMENT (of this Report) Distribution Unlimited; Approved for Public Release		
17 DISTRIBUTION STATEMENT (of the abstract entered in Block 20, if different from Report)		
18 SUPPLEMENTARY NOTES		
19 KEY WORDS (Continue on reverse side if necessary and identify by block number) Flow visualization Tunnel-fins		
20 ABSTRACT (Continue on reverse side if necessary and identify by block number) An experimental program was conducted at the David W. Taylor Naval Ship R&D Center (DTNSRDC) to aid in the identification and resolution of the hull vibration problem experienced by the Auxiliary Oiler AO 177 and to validate possible remedies. The formulated program included evaluations with three tunnel-fin configurations fitted to the stern of the model. The experiments involved visual flow observations, propulsion experiments and wake survey experiments. This report deals exclusively with the observations of the flow variations for three different tunnel-fin configurations. The propulsion experiments		

DD FORM 1473

1 JAN 73

EDITION OF 1 NOV 65 IS OBSOLETE

UNCLASSIFIED

SECURITY CLASSIFICATION OF THIS PAGE (When Data Entered)

UNCLASSIFIED

SECURITY CLASSIFICATION OF THIS PAGE (When Data Entered)

20. and wake survey experiments will be published in separate reports. An improved flow pattern was observed with the tunnel-fin designated as configuration number one.

UNCLASSIFIED

SECURITY CLASSIFICATION OF THIS PAGE(When Data Entered)

TABLE OF CONTENTS (U)

	Page
LIST OF FIGURES	iv
LIST OF TABLES	iv
ABSTRACT.	1
ADMINISTRATIVE INFORMATION	1
INTRODUCTION.	1
PROCEDURES	2
RESULTS.	2
CONCLUSIONS.	5

Accession For		
NTIS GRA&I	<input checked="" type="checkbox"/>	
DTIC TAB	<input type="checkbox"/>	
Unannounced	<input type="checkbox"/>	
Justification		
By		
Distribution/		
Availability Codes		
	Avail and/or	
Dist	Special	
A		

LIST OF FIGURES

	Page
1 - Illustration of Tunnel-fin Configuration 1	8
2 - Illustration of Tunnel-fin Configuration 2	9
3 - Illustration of Tunnel-fin Configuration 3	10
4 - Fitting Room Photographs of Tunnel-fin Configuration 1 Attached to Model .	11
5 - Fitting Room Photographs of Tunnel-fin Configuration 2 Attached to Model .	12
6 - Fitting Room Photographs of Tunnel-fin Configuration 3 Attached to Model .	13
7 - Photograph Denoting Number System for Key Tufts	14
8 - Photographs of Tufted Model Prior to Experiments	15
9 - Side View Photographs of Flow Patterns for Experiment 1	16
10 - Injection of Air and Bottom View Photographs of Flow Patterns for Experiment 1	17
11 - Side View Photographs of Flow Patterns for Experiment 2.	18
12 - Injection of Air and Bottom View Photographs of Flow Patterns for Experiment 2	19
13 - Side View Photographs of Flow Patterns for Experiment 7	20
14 - Bottom View Photograph of Flow Patterns for Experiment 7	21
15 - Side and Bottom View Photographs of Experiment 4	22
16 - Side and Bottom View Photographs of Experiment 3	23
17 - Side and Bottom View Photographs of Experiment 6	24
18 - Side and Bottom View Photographs of Experiment 5	25
19 - Side and Bottom View Photographs of Experiment 9	26
20 - Side and Bottom View Photographs of Experiment 10.	27

LIST OF TABLES

1 - Experimental Configurations and Ship Values	7
---	---

ABSTRACT

An experimental program was conducted at the David W. Taylor Naval Ship R&D Center (DTNSRDC) to aid in the identification and resolution of the hull vibration problem experienced by the Auxiliary Oiler AO 177 and to validate possible remedies. The formulated program included evaluations with three tunnel-fin configurations fitted to the stern of the model. The experiments involved visual flow observations, propulsion experiments and wake survey experiments. This report deals exclusively with the observations of the flow variations for three different tunnel-fin configurations. The propulsion experiments and wake survey experiments will be published in separate reports. An improved flow pattern was observed with the tunnel-fin designated as configuration number one.

ADMINISTRATIVE INFORMATION

The Naval Sea Systems Command (NAVSEA) initiated a model experimental program at David Taylor Naval Ship R&D Center (DTNSRDC) to evaluate the effects of the addition of various tunnel-fins to the stern of Model 5326-1 representing the AO 177. Work was authorized by NAVSEA Project Orders POOR144 and POOR146, and the work was completed under DTNSRDC Work Unit Numbers 1-1532-110 and 1532-115.

INTRODUCTION

Three tunnel-fin designs were constructed and fitted to existing Model 5326-1 according to plans furnished by NAVSEA, entitled "Flow Improvement Fin" and designated Configuration 1 (SK 3213-0026), Configuration 2 (SK 3213-0027), and Configuration 3 (SK 3213-0028). Model 5326-1 representing the Auxiliary Oiler AO 177 was previously constructed to a linear ratio of 25.682. The model was fitted with the same bilge keel and rudder arrangement which were on the model during the previous flow observation experiments. Illustrations of the three tunnel-fins are shown in Figure 1 (Configuration 1), Figure 2 (Configuration 2), and Figure 3 (Configuration 3). Fitting room photographs of the fins attached to the model are presented in Figures 4 through 6.

PROCEDURES

Tufts were secured to the model to denote the flow patterns for the different experiments. Tufts which are in the area of greatest interest have been numbered for ease of identification and for comparison between different experiments. This numbering system, which is carried through on all the flow visualization photographs, is shown in Figure 7. The tufts on station 19 and forward were secured about 1 inch (2.54 cm) out from the hull surface by the use of pins in order to observe the flow into the fins out from the hull surface. All other tufts aft of station 19 were attached directly to the model surface. Photographs of the model with tufts attached prior to the commencement of the experiments are presented as Figure 8.

A check experiment was run to validate previous experiments with the stock propeller and also observe the variation in flow patterns due to a difference in propeller diameter. The stock propeller (Propeller 4372A) had a full-scale diameter of 23 feet (7.01 meters) and the design propeller (Propeller 4645) had a ship diameter of 21 feet (6.40 meters).

Some of the figures presented include two photographs of the same experiment which are given in an attempt to show the extreme movement of a particular tuft.

Air was injected into the water flow 8 inches (20.32 cm) upstream from the propeller and photographs taken to show an area of concern when the air was clinging to the hull.

A simulated ship speed of 20 knots was maintained throughout the experiments. The model was held in a 0 degree yaw position and was free to trim. Table 1 on page 7 is a listing of the model configurations and ship values for each experiment.

RESULTS

Figure 9 shows the flow pattern for Experiment 1 at the following ship values and configurations;

No fins	
Displacement	26,390 tons (26 810 metric tons)
Trim	1' x bow (0.305 meters)
Propeller diameter	21 feet (6.40 meters)
RPM	95
Speed	20 Knots

Tufts numbered 3 and 4 are in a turbulent flow which sometimes reverses causing these tufts to point upstream. Note the different positions of tuft number 3 in both photographs in Figure 9. Tuft number 2 has a lazy up and down motion and

shows no reverse flow in that area. A photograph of air being injected into the water is given in Figure 10. The air has been outlined for better viewing. The air rises along the hull and hangs against the hull around tuft number 3 before moving off. Figure 10 also includes a photograph showing the flow pattern from a bottom view.

Figure 11 gives the flow patterns for Experiment 2 at the following ship values and configuration;

No fins	
Displacement	17,270 tons (17 550 metric tons)
Trim	3.75' x stern (1.143 meters)
Propeller diameter	21 feet (6.40 meters)
RPM	95
Speed	20 Knots

Tuft number 4 is out of the water and is no longer visible. Tuft number 3 is a little more erratic than when observed during Experiment 1 with more reverses upstream. Tuft number 2 also reverses occasionally. Figure 12 is a photograph of air clinging to the hull before moving off downstream. Also presented in Figure 12 is a bottom view of the flow pattern.

After viewing the flow patterns for Experiments 1 and 2 it was noted that these flow patterns did not conform to those reported in May 1974.¹ The May 1974 experiment used a different propeller and had a different trim and displacement. It was decided to repeat the May 1974 experiment with the following ship values and configuration;

No fins	
Displacement	27,380 tons (27 820 metric tons)
Trim	1.5' x stern (0.457 meters)
Propeller diameter	23 feet (7.01 meters)
RPM	98.7
Speed	20 Knots

Figure 13 gives the flow pattern for this experiment (Experiment 7). Tufts 3 and 4 do not have the same erratic movement as observed in Experiments 1 and 2. The photographs show the maximum movement of these tufts. There was no reverse flow observed as the flow was obviously improved over that encountered in Experiments 1 and 2. Figure 14 is a bottom view of the flow pattern for Experiment 7.

Experiment 8 was conducted to show the variation in flow patterns due to the different size propellers with all other experimental conditions remaining the same as Experiment 7. The ship values and configurations are as follows:

No fins	
Displacement	27,380 tons (27 820 metric tons)
Trim	1.5' x stern (0.457 meters)
Propeller diameter	21 feet (6.40 meters)
RPM	98.7
Speed	20 knots

This experiment revealed that increasing the propeller diameter from 21 feet (6.40 m) in Experiment 8 to 23 feet (7.01 m) in Experiment 7 improved the observed flow patterns. It also revealed that changing the trim from 1 foot (0.305 m) by the bow (Experiment 1) to 1.5 feet (0.457 m) by the stern (Experiment 8) does not change the erratic flow patterns. Photographs for Experiment 8 are not included since the flow patterns observed were similar to the flow observed in Experiment 1.

Figures 15 and 16 show the flow patterns for Experiments 3 and 4 at the following ship values and configurations;

	Experiment 3	Experiment 4
Fin configuration	1	1
Displacement	17,270 tons (17 550 metric tons)	26,390 tons (26 810 metric tons)
Trim	3.75' x stern (1.143 meters)	1' x bow (0.305 meters)
Propeller diameter	21 feet (6.40 meters)	21 feet (6.40 meters)
RPM	95	95
Speed	20 knots	20 knots

There were no unusual flow patterns with these experiments except for some unsteady flow at the trailing edge of the tunnel-fin. However, there was no visible separation in that area. Air injected into the water flow does not rise but moves directly through the propeller plane.

Figures 17 (Experiment 6) and 18 (Experiment 5) give the flow patterns at the following ship values and configurations;

	Experiment 5	Experiment 6
Fin configuration	2	2
Displacement	17,270 tons (17 550 metric tons)	26,390 tons (26 810 metric tons)
Trim	3.75' x stern (1.143 meters)	1' x bow (0.305 meters)
Propeller diameter	21 feet (6.40 meters)	21 feet (6.40 meters)
RPM	95	95
Speed	20 knots	20 knots

There were two areas of concern noticed with this fin configuration. One is the severe separation which occurs at the trailing edge of the fins and the second is the large amount of air trapped under the fins when air is released into the flow.

The air moves up to the fin and then moves upstream along the fin to form large pockets of trapped air. Both the separation and the trapped air are shown in Figure 18. The separation at the trailing edge was not as severe for Experiment 6 (displacement 26,390 tons (26 810 metric tons)).

Figures 19 and 20 show the flow patterns for Experiments 9 and 10 at the following ship values and configurations;

	Experiment 9	Experiment 10
Fin configuration	3	3
Displacement	26,390 tons (26 810 metric tons)	17,270 (17 550 metric tons)
Trim	1' x bow (0.305 meters)	3.75' x stern (1.143 meters)
Propeller diameter	21 feet (6.40 meters)	21 feet (6.40 meters)
RPM	95	95
Speed	20 knots	20 knots

There were no unusual flow patterns with these experiments except that the flow did not appear as strong on the bottom side of the fins as the flow observed with Experiment 3 (tunnel-fin configuration 1). Also the turbulent flow at the trailing edge was greater than that observed with Experiment 3. The flow would otherwise be considered good. Air injected into the water flow does not rise but moves directly through the propeller plane.

CONCLUSIONS

The detrimental water flow observed in experiments 1 and 2 can be corrected by the addition of tunnel-fin configuration 1. The flow pattern observed with configuration 2 is also acceptable. However, this flow did not have the magnitude of the accelerated velocity into the propeller plane that was observed with configuration 1.

Configuration 2 was not acceptable because of the separation at the blunt trailing edge and the reverse flow on the bottom side indicated by the trapped air.

It is interesting to note that the unacceptable flow patterns became acceptable when the propeller diameter was increased from 21 feet (6.40 meters) in Experiment 6 to 23 feet (7.01 meters) in Experiment 7.

TABLE 1 - EXPERIMENTAL CONFIGURATIONS AND SHIP VALUES

Experiment No.	Propeller No.	Propeller feet	Diameter meters	Fin Configuration	Displacement tons	Displacement metric tons	RPM	Trim feet	Trim meters
1	4645	21	6.40	none	26,390	26 0	95	1' x bow	0.305
2	4645	21	6.40	none	17,270	17 550	95	3.75' x stern	1.143
3	4645	21	6.40	1	17,270	17 550	95	3.75' x stern	1.143
4	4645	21	6.40	1	26,390	26 810	95	1' x bow	0.305
5	4645	21	6.40	2	17,270	17 550	95	3.75' x stern	1.143
6	4645	21	6.40	2	26,390	26 810	95	1' x bow	0.305
7	4372A	23	7.01	none	27,380	27 820	98.7	1.5' x stern	0.457
8	4645	21	6.40	none	27,380	27 820	98.7	1.5' x stern	0.457
9	4645	21	6.40	3	26,390	26 810	95	1' x bow	0.305
10	4645	21	6.40	3	17,270	17 550	95	3.75' x stern	1.143

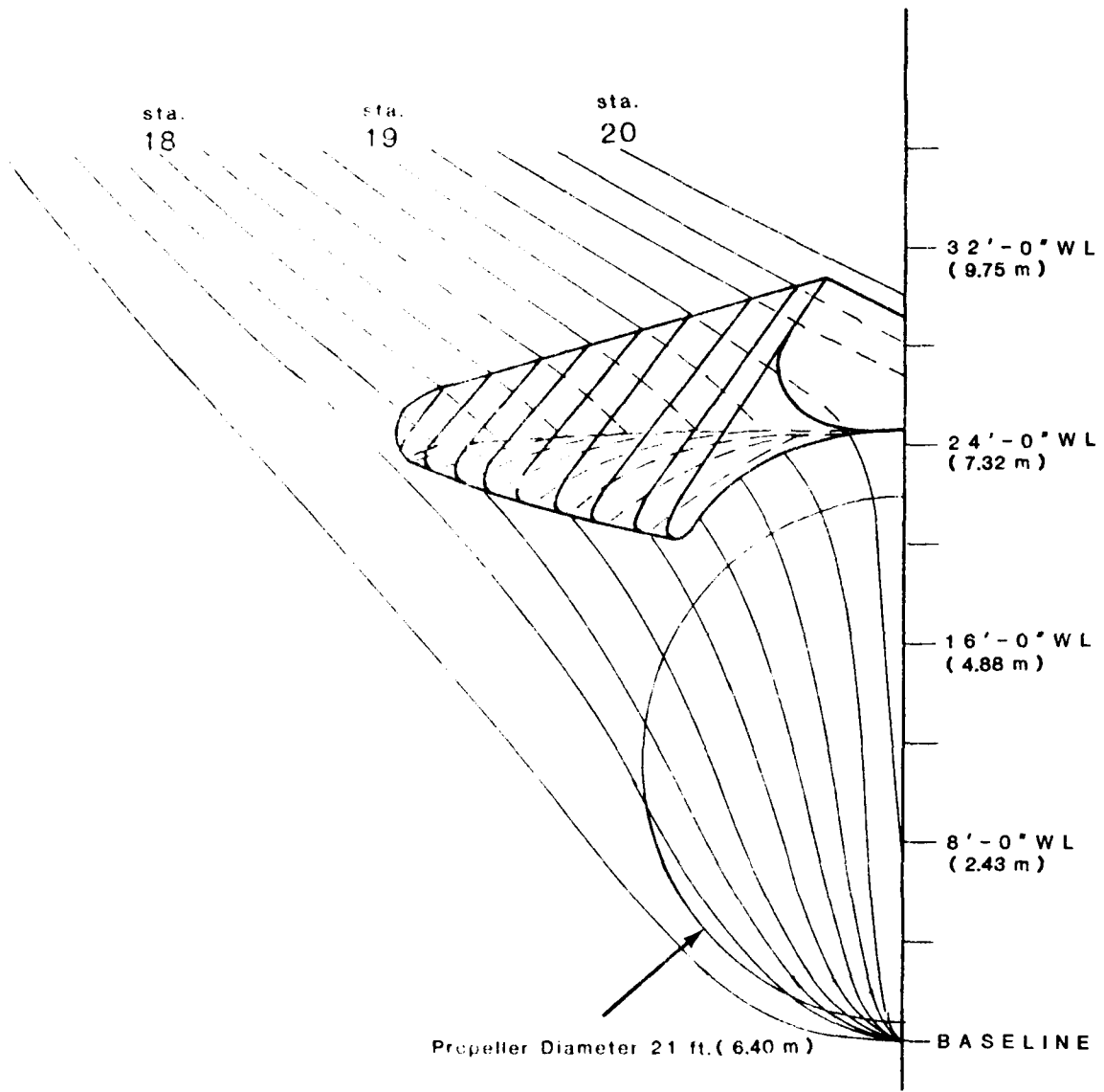

Figure 1 - Illustration of Tunnel-fin Configuration 1

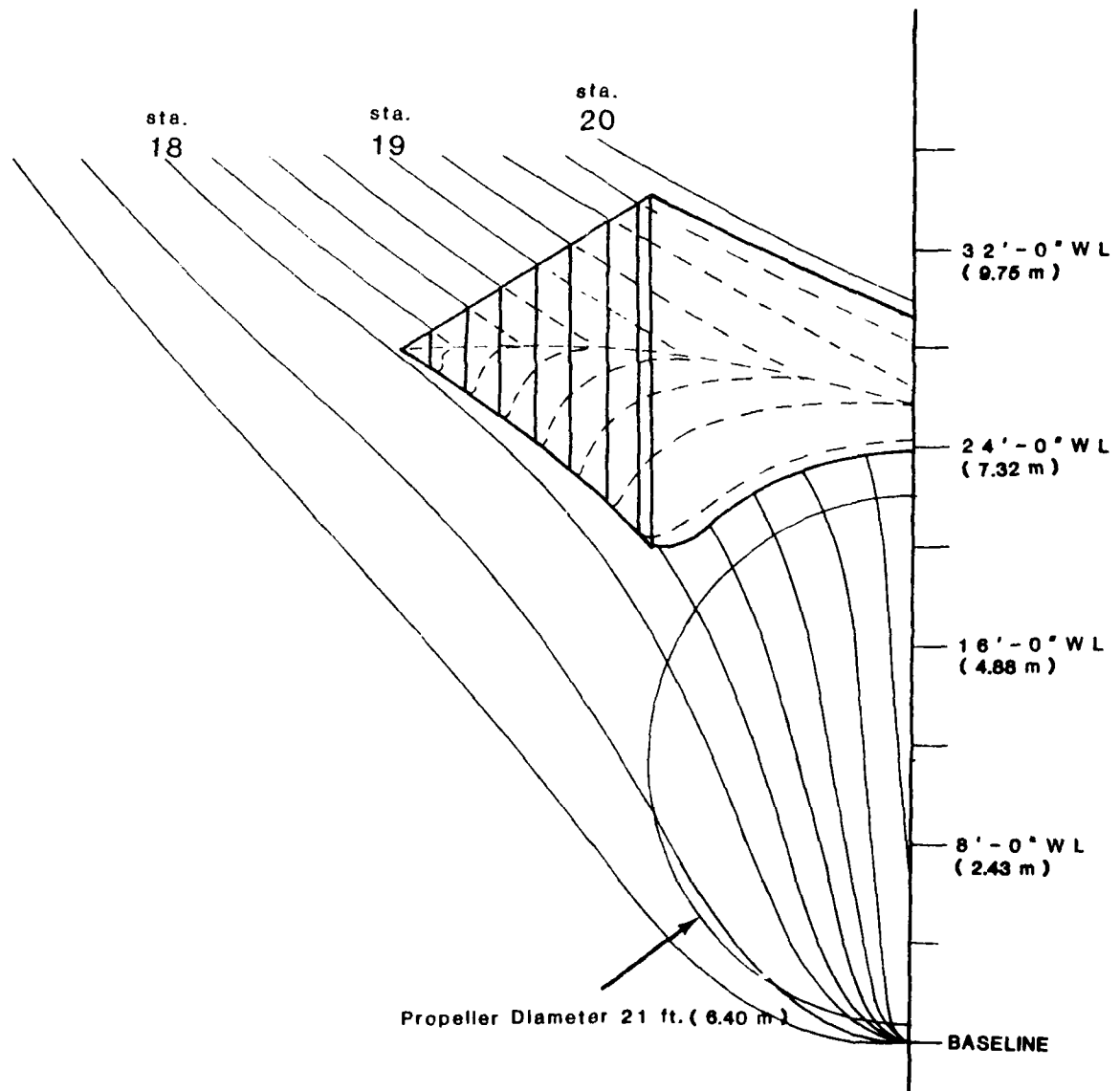

Figure 2 - Illustration of Tunnel-fin Configuration 2

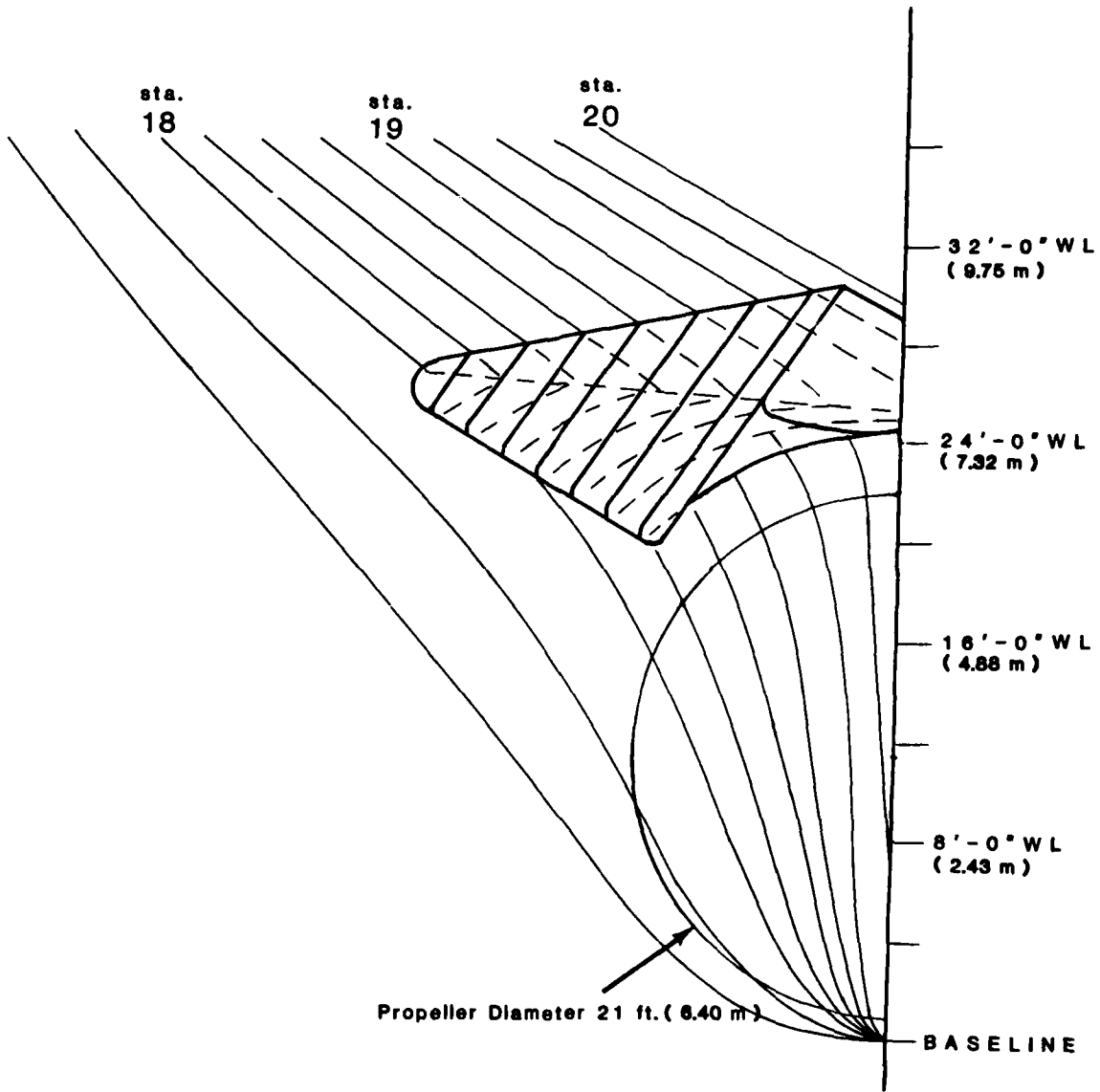

Figure 3 - Illustration of Tunnel-fin Configuration 3

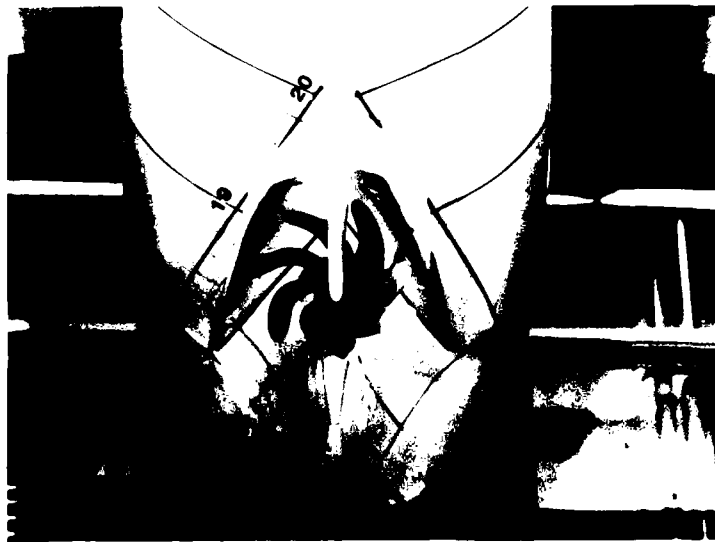
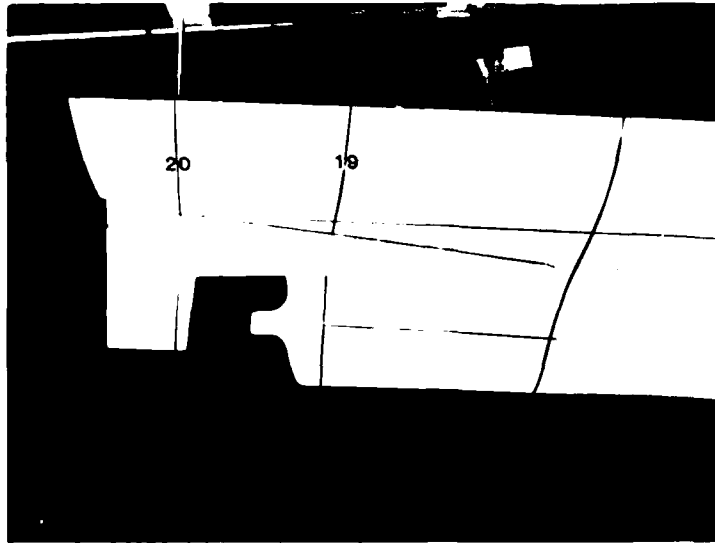

Figure 4 - Fitting Room Photographs of Tunnel-fin Configuration 1
Attached to Model

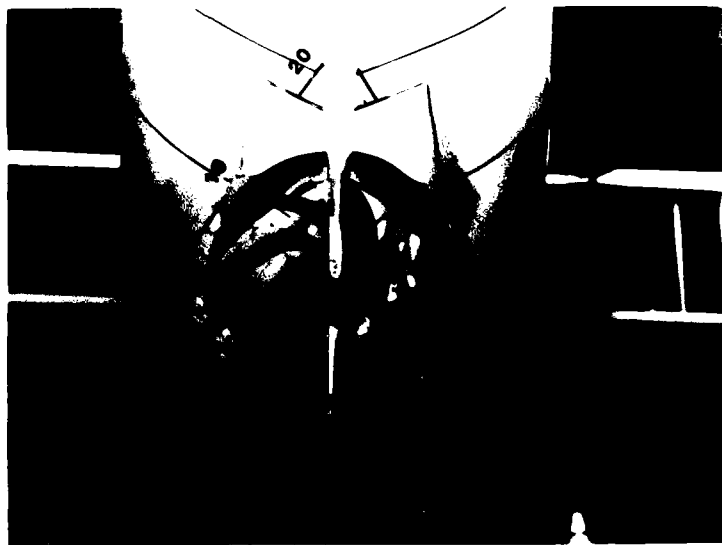
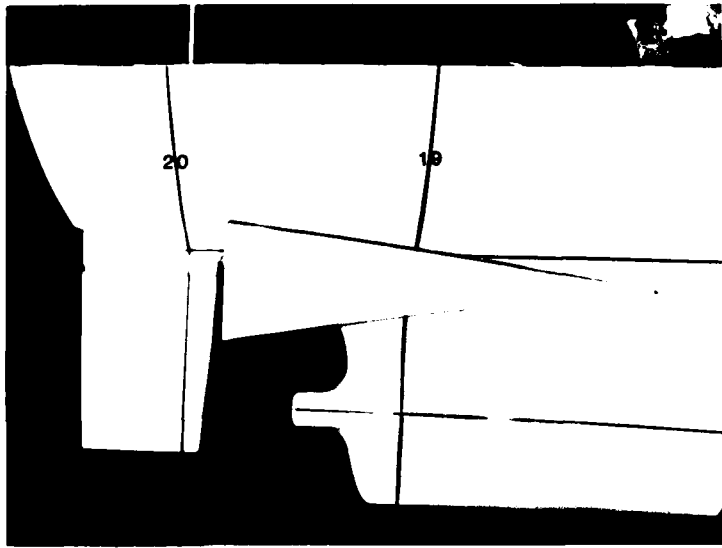

Figure 5 - Fitting Room Photographs of Tunnel-fin Configuration 2
Attached to Model

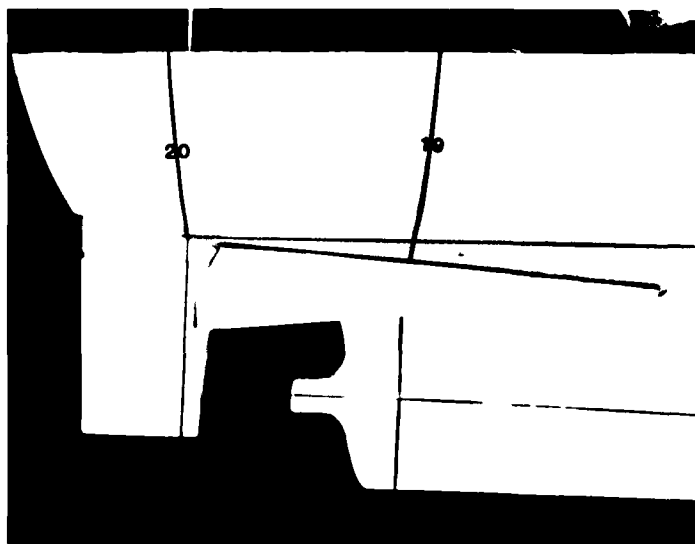

Figure 6 - Fitting Room Photographs of Tunnel-fin Configuration 3
Attached to Model

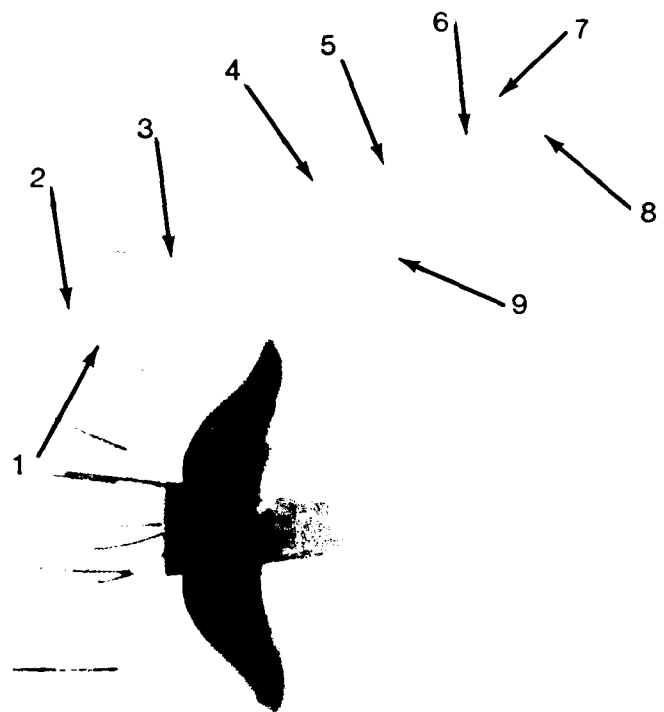

Figure 7 - Photograph Denoting Number System for Key Tufts



Figure 8 - Photographs of Tufted Model Prior to Experiments

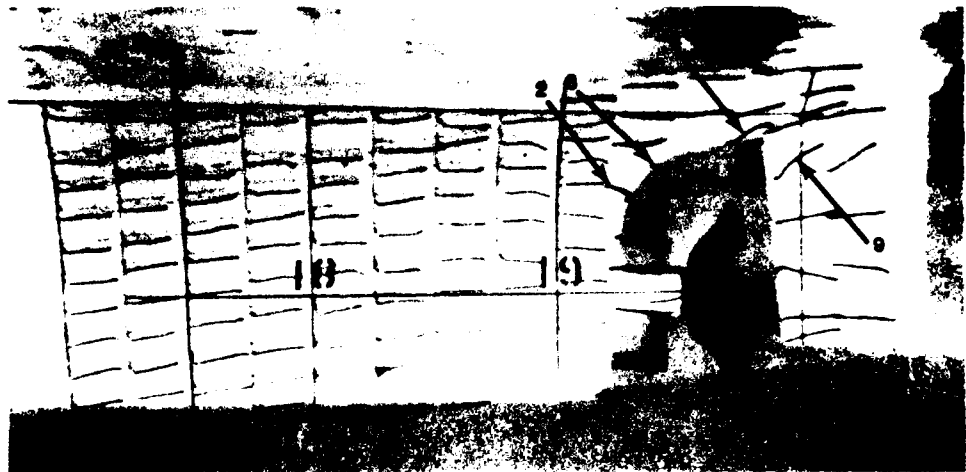
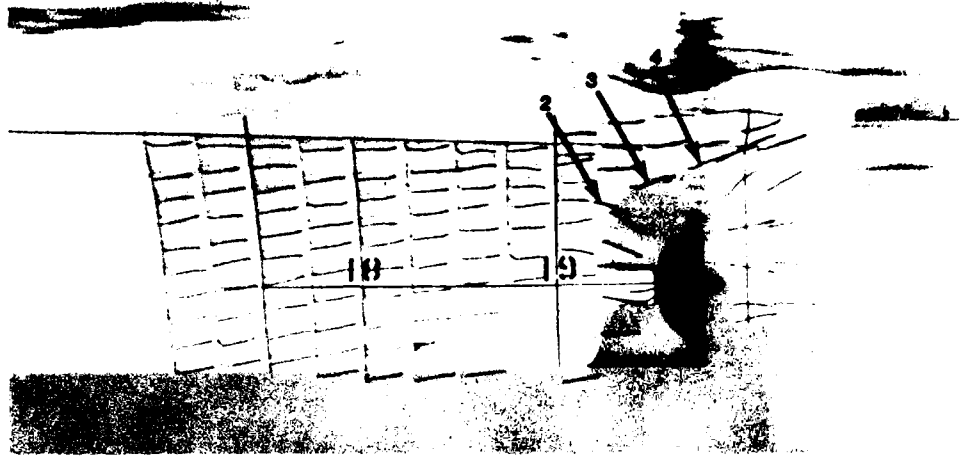

Figure 9 - Side View Photographs of Flow Patterns for Experiment 1

No fins	
Displacement	26,390 tons (26 810 metric tons)
Trim	1' x bow (0.350 meters)
Propeller diameter	21 feet (6.40 meters)
RPM	95
Speed	20 knots

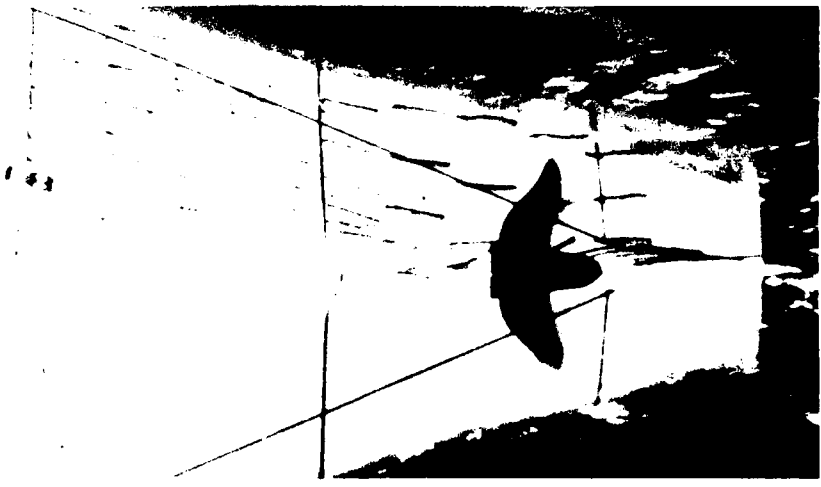
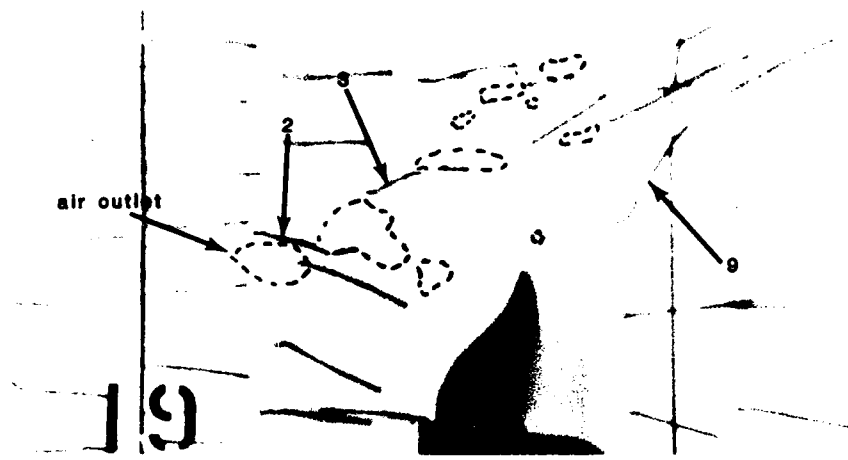

Figure 10 - Injection of Air and Bottom View Photographs of Flow Patterns for Experiment 1

No fins	
Displacement	26,390 tons (26 810 metric tons)
Trim	1' x bow (0.350 meters)
Propeller diameter	21 feet (6.40 meters)
RPM	95
Speed	20 knots

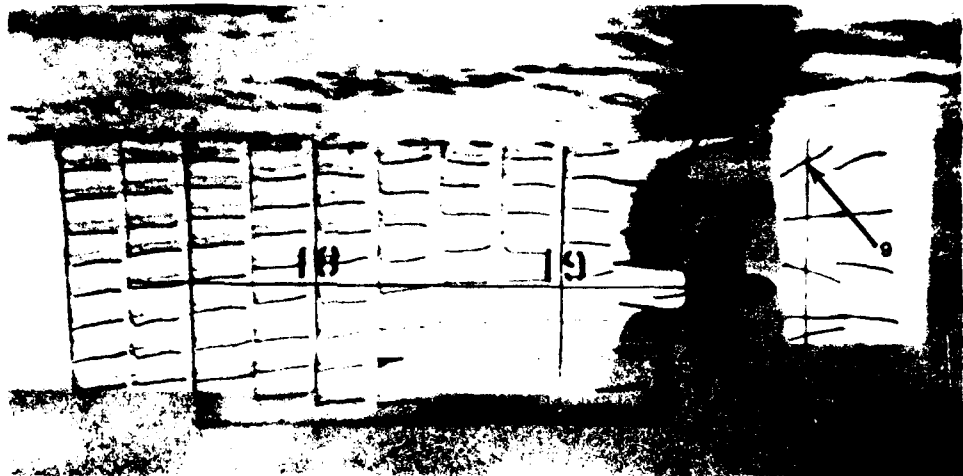
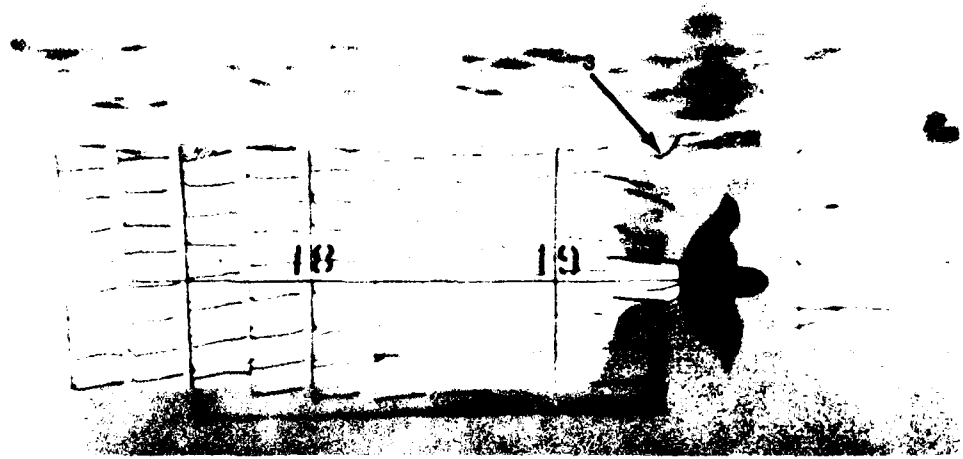

Figure 11 - Side View Photographs of Flow Patterns for Experiment 2

No fins	
Displacement	17,270 tons (17 550 metric tons)
Trim	3.75' x stern (1.143 meters)
Propeller diameter	21 feet (6.40 meters)
RPM	95
Speed	20 knots

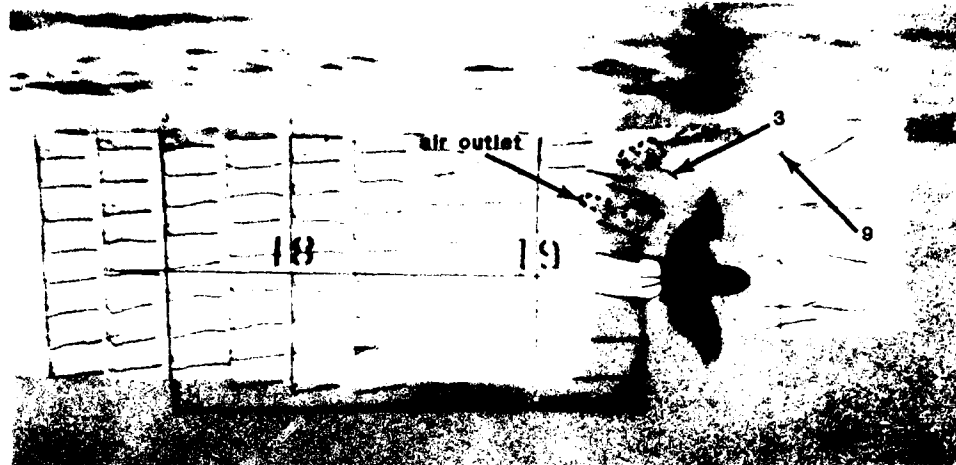

Figure 12 - Injection of Air and Bottom View Photographs of Flow Patterns for Experiment 2

No fins	
Displacement	17,270 tons (17 550 metric tons)
Trim	3.75' x stern (1.143 meters)
Propeller diameter	21 feet (6.40 meters)
RPM	95
Speed	20 knots

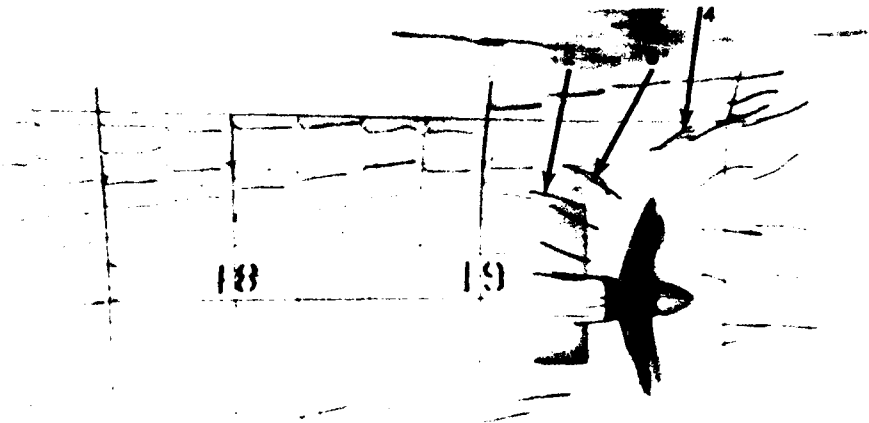
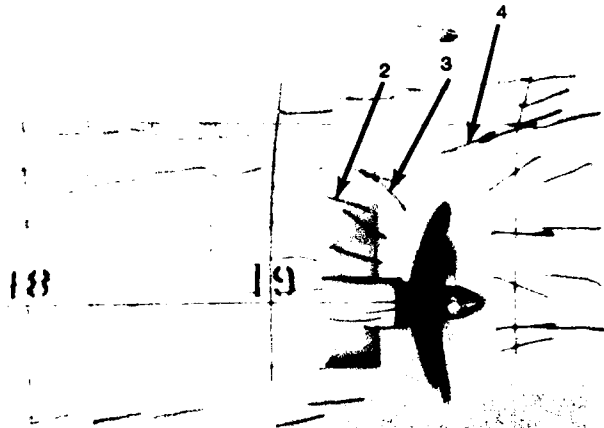

Figure 13 - Side View Photographs of Flow Patterns for Experiment 7

No fins	
Displacement	27,380 tons (27 820 metric tons)
Trim	1.5' x stern (0.457 meters)
Propeller diameter	23 feet (7.01 meters)
RPM	98.7
Speed	20 knots

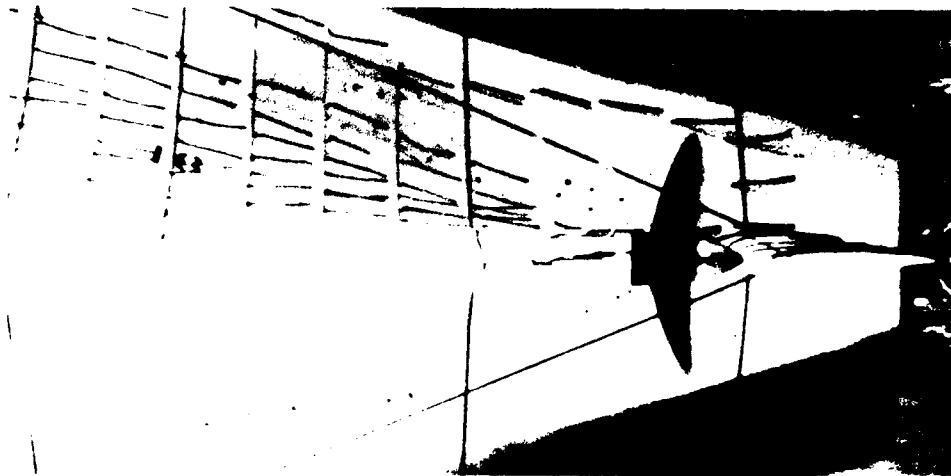

Figure 14 - Bottom View Photograph of Flow Patterns for Experiment 7

No fins	
Displacement	27,380 tons (27 820 metric tons)
Trim	1.5' x stern (0.457 meters)
Propeller diameter	23 feet (7.01 meters)
RPM	98.7
Speed	20 knots



Figure 16 - Side and Bottom View Photographs of Experiment 3

Fin configuration	1
Displacement	17,270 tons (17 550 metric tons)
Trim	3.75' x stern (1.143 meters)
Propeller diameter	21 feet (6.40 meters)
RPM	95
Speed	20 knots

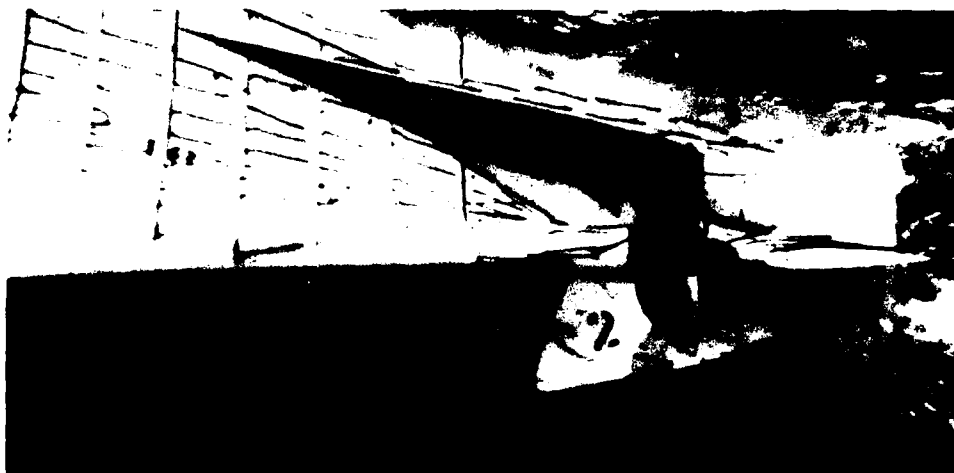
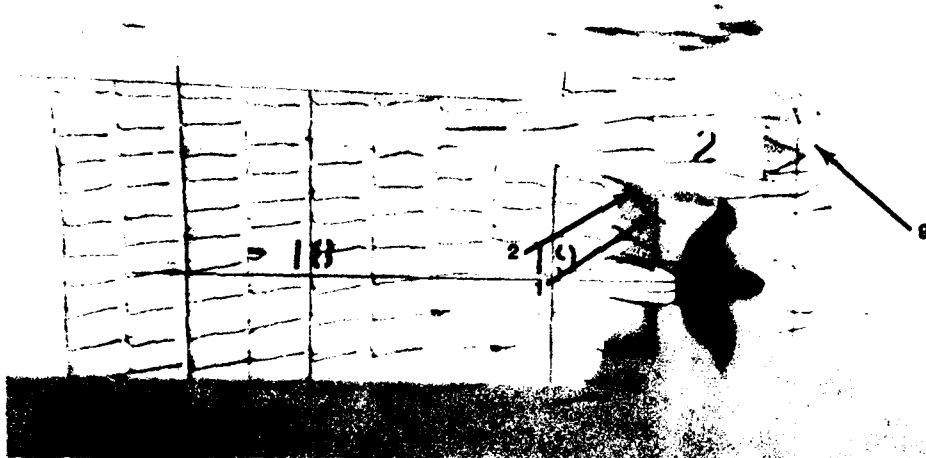

Figure 17 - Side and Bottom View Photographs of Experiment 6

Fin configuration	2
Displacement	26,390 tons (26 810 metric tons)
Trim	1' x bow (0.305 meters)
Propeller diameter	21 feet (6.40 meters)
RPM	95
Speed	20 knots

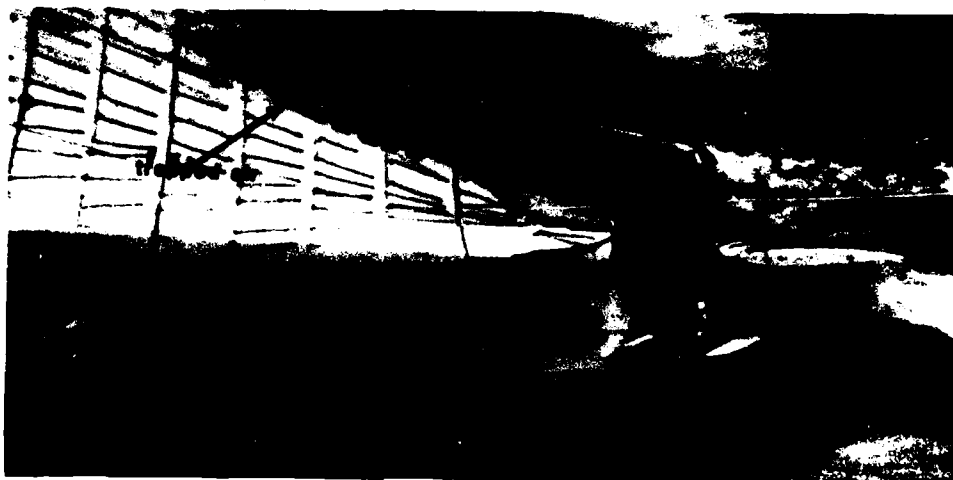

Figure 18 - Side and Bottom View Photographs of Experiment 5

Fin configuration	2
Displacement	17,270 tons (17 550 metric tons)
Trim	3.75' x stern (1.143 meters)
Propeller diameter	21 feet (6.40 meters)
RPM	95
Speed	20 knots

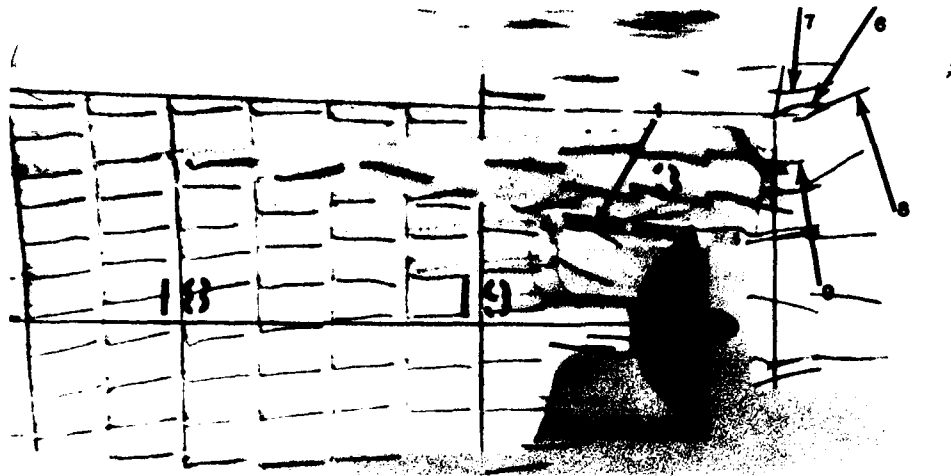

Figure 19 - Side and Bottom View Photographs of Experiment 9

Fin configuration	3
Displacement	26,390 tons (26 810 metric tons)
Trim	1' x bow (0.305 meters)
Propeller diameter	21 feet (6.40 meters)
RPM	95
Speed	20 knots

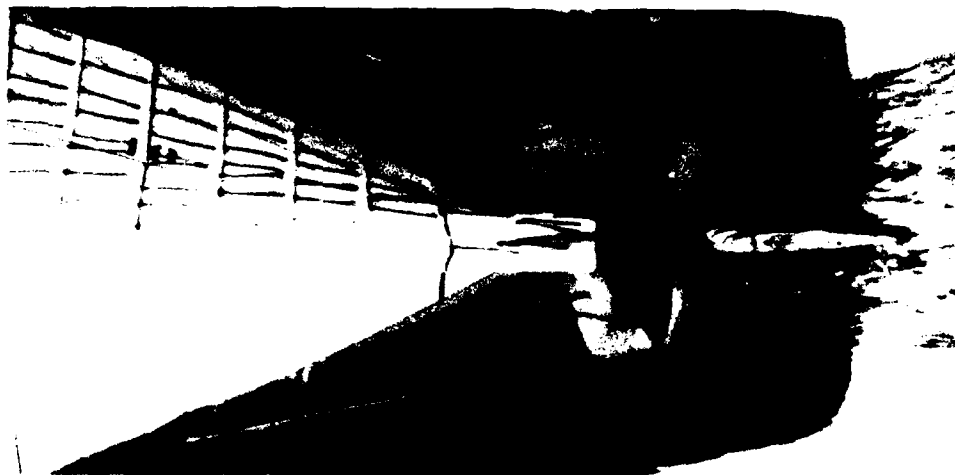
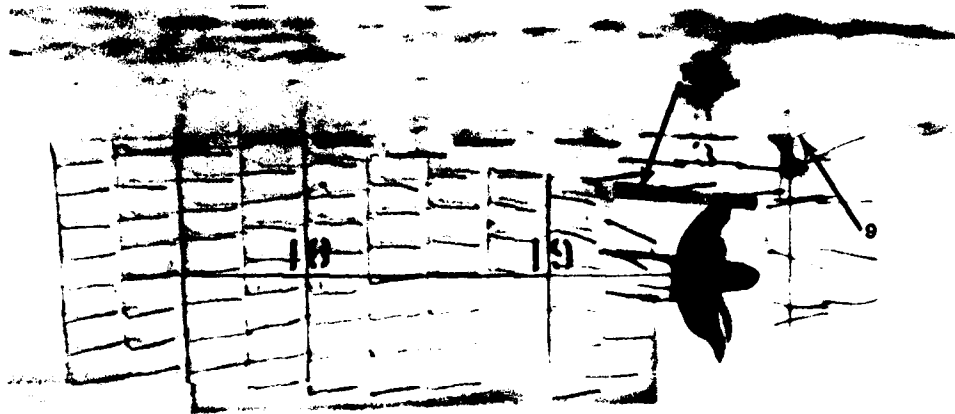

Figure 20 - Side and Bottom View Photographs of Experiment 10

Fin configuration	3
Displacement	17,270 (17 550 metric tons)
Trim	3.75' x stern (1.143 meters)
Propeller diameter	21 feet (6.40 meters)
RPM	95
Speed	20 knots

DTNSRDC ISSUES THREE TYPES OF REPORTS

1. DTNSRDC REPORTS, A FORMAL SERIES, CONTAIN INFORMATION OF PERMANENT TECHNICAL VALUE. THEY CARRY A CONSECUTIVE NUMERICAL IDENTIFICATION REGARDLESS OF THEIR CLASSIFICATION OR THE ORIGINATING DEPARTMENT.

2. DEPARTMENTAL REPORTS, A SEMIFORMAL SERIES, CONTAIN INFORMATION OF A PRELIMINARY, TEMPORARY, OR PROPRIETARY NATURE OR OF LIMITED INTEREST OR SIGNIFICANCE. THEY CARRY A DEPARTMENTAL ALPHANUMERICAL IDENTIFICATION.

3. TECHNICAL MEMORANDA, AN INFORMAL SERIES, CONTAIN TECHNICAL DOCUMENTATION OF LIMITED USE AND INTEREST. THEY ARE PRIMARILY WORKING PAPERS INTENDED FOR INTERNAL USE. THEY CARRY AN IDENTIFYING NUMBER WHICH INDICATES THEIR TYPE AND THE NUMERICAL CODE OF THE ORIGINATING DEPARTMENT. ANY DISTRIBUTION OUTSIDE DTNSRDC MUST BE APPROVED BY THE HEAD OF THE ORIGINATING DEPARTMENT ON A CASE-BY-CASE BASIS.

DATE
FILMED
— 8