

AD-A094 868

STANFORD UNIV CA DIV OF APPLIED MECHANICS

F/6 11/4

A ONE-DIMENSIONAL EFFECTIVE DISPERSION THEORY FOR LAYERED COMPO--ETC(U)

NOV 80 T J DELPH, G HERRMANN

N00014-76-C-0054

UNCLASSIFIED

SUDAM-80-7

NL

1 of 1  
2/24-89

END  
DATE  
FORMED  
3 8 11  
DTIC

# LEVEL

12

Office of Naval Research  
Department of the Navy  
Scientific Report  
Contract N00014-76-C-0054

AD A094868

A ONE-DIMENSIONAL EFFECTIVE DISPERSION  
THEORY FOR LAYERED COMPOSITES

by  
T. J. Delph  
and  
G. Herrmann

DTIC  
SELECTED  
FEB 10 1981  
S C

SUDAM Report No. 80-7

November 1980

This document has been approved for  
public release and sale; its distribution  
if unlimited.

DIVISION  
OF  
APPLIED  
MECHANICS

DEPARTMENT  
OF  
MECHANICAL  
ENGINEERING

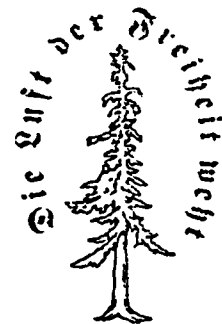

STANFORD  
UNIVERSITY  
STANFORD,  
CALIFORNIA  
94305

DDC FILE COPY

UNCLASSIFIED

SECURITY CLASSIFICATION OF THIS PAGE (When Data Entered)

4/5/80 87 11

REPORT DOCUMENTATION PAGE		READ INSTRUCTIONS BEFORE COMPLETING FORM
1. REPORT NUMBER	2. GOVT ACCESSION NO. AD-A044868	3. RECIPIENT'S CATALOG NUMBER
4. TITLE (and Subtitle) A ONE-DIMENSIONAL EFFECTIVE DISPERSION THEORY FOR LAYERED COMPOSITES		5. TYPE OF REPORT & PERIOD COVERED INTERIM
7. AUTHOR(s) T. J. DELPH and G. HERRMANN		6. PERFORMING ORG. REPORT NUMBER
9. PERFORMING ORGANIZATION NAME AND ADDRESS DIVISION OF APPLIED MECHANICS STANFORD UNIVERSITY STANFORD, CALIFORNIA 94305		8. CONTRACT OR GRANT NUMBER(s) N00014-76-C-0054
11. CONTROLLING OFFICE NAME AND ADDRESS OFFICE OF NAVAL RESEARCH DEPARTMENT OF THE NAVY ARLINGTON, VIRGINIA 22217		10. PROGRAM ELEMENT, PROJECT, TASK AREA & WORK UNIT NUMBERS NR 064-525
14. MONITORING AGENCY NAME & ADDRESS (if different from Controlling Office)		12. REPORT DATE November 1980
		13. NUMBER OF PAGES 33
		15. SECURITY CLASS. (of this report) UNCLASSIFIED
		15a. DECLASSIFICATION/DOWNGRADING SCHEDULE
16. DISTRIBUTION STATEMENT (of this Report) APPROVED FOR PUBLIC RELEASE: DISTRIBUTION UNLIMITED.		
17. DISTRIBUTION STATEMENT (of the abstract entered in Block 20, if different from Report)		
18. SUPPLEMENTARY NOTES		
19. KEY WORDS (Continue on reverse side if necessary and identify by block number) COMPOSITES LAMINATES WAVE PROPAGATION DISPERSION		
20. ABSTRACT (Continue on reverse side if necessary and identify by block number) A new approximate theory for wave propagation in a periodically-layered elastic body is proposed. The theory is based on microstructural theories of elasticity, and makes use of a collocation technique in conjunction with the exact solution for wave propagation in an unbounded elastic body. The results are in excellent agreement with the exact solution. The new theory is considered to hold considerable promise for formulating approximate solutions to boundary-initial value problems for composite bodies.		

410000

JL

ABSTRACT

A new approximate theory for wave propagation in a periodically-layered elastic body is proposed. The theory is based on microstructural theories of elasticity, and makes use of a collocation technique in conjunction with the exact solution for wave propagation in an unbounded elastic body. The results are in excellent agreement with the exact solution.

The new theory is considered to hold considerable promise for formulating approximate solutions to boundary-initial value problems for composite bodies.

Accession For	
NTIS GRA&I	<input checked="" type="checkbox"/>
DTIC TAB	<input type="checkbox"/>
Unannounced	<input type="checkbox"/>
Justification	
By _____	
Distribution/	
Availability Codes	
Dist	Special
A	

## 1. INTRODUCTION

1

The increasing use of layered composites in light-weight, high-strength structures has led to a corresponding increase in efforts to analyze the dynamic behavior of these materials. In most of these analyses, the composite is modeled as a periodically layered body, with the constituent layers composed of homogeneous, linearly elastic material. The layers may be assumed to be isotropic or to have some specified anisotropy. Initial/boundary value problems may then be formulated for such a body within the framework of the classical theory of elasticity, but the heterogeneous nature of the body makes exact solutions very difficult to obtain. For this reason, an approximate theory is usually required for practical applications.

If the wavelengths of interest are considerably greater than the characteristic layer thicknesses, then the *effective modulus* theory may be used. Here the body is modeled as a homogeneous, but anisotropic, solid, with the material constants derived in some fashion from the properties of the constituent layers. The effective modulus theory becomes invalid, however, when the wavelengths are on the order of the layer thicknesses. At these shorter wavelengths, the successive reflection and refraction of waves from layer interfaces tends to break down the structure of progressive waves. This leads to a marked dispersive effect not predicted by the effective modulus theory.

To account for this dispersive effect, an approximate theory which in some fashion takes into account the heterogeneous nature of the body is required. A number of such theories, which could be collectively called *microstructural theories*, have appeared in the literature in recent years. A representative bibliography is given in [1].

In this paper, we set forth a new microstructural theory for wave propagation normal to the layering in a periodically layered solid. The new

theory, to be known as the *effective dispersion theory*, is conceptually simple, yet seems to be significantly more accurate than other existing theories.

The effective dispersion theory is based in part upon concepts of linear elasticity with microstructure set forth in the work of Mindlin [2] and Kunin [3]. In the general theories of these authors, no definite procedure is given for determining the coefficients in the differential equations of motion. In the effective dispersion theory, these coefficients are determined by matching as closely as possible the resulting approximate dispersion spectrum to the exact dispersion spectrum for wave propagation normal to the layering in an unbounded body. It is from this matching procedure that the effective dispersion theory takes its name. In addition, it is possible to match the approximate and exact mode shapes at the end of the first Brillouin zone.

The additional requirements that the approximate spectrum have real frequencies for all values of wave numbers, and that the coefficients of the equations of motion be real, serve to completely fix the coefficients in the approximate equations of motion. These additional requirements, however, impose certain restrictions upon the classes of materials for which the effective dispersion theory is valid.

The resulting theory represents a significant improvement over most existing approximate theories. Not only is it quantitatively valid for much shorter wavelengths than most of the earlier theories, but, perhaps more importantly, it embodies the first stopping band of the spectrum, i.e. the complex branch between the first and second Brillouin zones. Thus the filtering property of a periodic structure is contained in the theory, even though periodicity as such is no longer present in the approximate spectrum.

## 2. EQUATIONS OF MOTION

The layered solid is assumed to be composed of periodically alternating layers of homogeneous, isotropic, linearly elastic material (Fig. 1). The layers have thicknesses  $2h$  ;  $2h'$  , densities  $\rho$  ;  $\rho'$  , and elastic constants  $(\lambda, \mu)$  ;  $(\lambda', \mu')$  . Any two adjacent layers define a unit cell, which is repeated periodically along the positive and negative  $y$ -axes. For our purposes, the body will be considered to be of unbounded extent along the  $x$ - and  $z$ -axes, and bounded in the  $y$ -direction by two planes located at  $y = y_0$  and  $y = y_1$  having their normals parallel to the  $y$ -axis.

For wave propagation normal to the layering, the wave motion uncouples into longitudinal and shear wave motions, [4], which may be analyzed separately. In the interest of definiteness, we will consider only shear wave motions, as the case of longitudinal waves proceeds in exactly analogous fashion.

For shear wave motions, the  $u$ -displacement parallel to the  $x$ -axis is assumed to be the only non-zero component of displacement. Then the displacements in the  $N$ -th unit cell are assumed to be given by

$$u(y,t) = u_0(y,t) \Big|_{y_N=0} + y_N \psi(y,t) \Big|_{y_N=0} , \quad u'(y,t) = u'_0(y,t) \Big|_{y'_N=0} . \quad (1)$$

Here  $u$  and  $u'$  are, respectively, the displacement components parallel to the layering in the softer (unprimed) layer and the stiffer (primed) layer. By the stiffer and softer layers, we mean, respectively, the layers with the greater and lesser characteristic shear wave speeds. Here  $y_N$  is a local coordinate with origin at the midplane and  $|_{y_N=0}$  indicates the global  $y$ -coordinate is to be evaluated at the layer midplane.

Equation (1) follows, to some extent, corresponding assumptions made in Mindlin's microstructural theory [2] and the effective stiffness theory for composites [5]. Here, however, we assume that the displacement field

within the stiffer layers is constant, implying that all the deformation is confined to the softer layers. For the typical composite used in structural applications, the moduli of the stiffer layers are on the order of 50 to 100 times greater than those in the softer layers. Thus for such materials this assumption can be expected to agree well with reality at the lower frequencies and wave numbers for which the effective dispersion theory is valid.

Following the notation of [5], we now define

$$\begin{aligned}
 e_{12} &= u_{0,y}/2 \\
 \gamma_{21} &= u_{0,y} - \psi \\
 \theta_{221} &= \frac{\partial}{\partial y} (\gamma_{21}) = u_{0,yy} - \psi_{,y} \\
 \kappa_{221} &= \psi_{,y}
 \end{aligned}
 \tag{2}$$

where  $e_{12}$  is known as the macro-strain,  $\gamma_{21}$  the relative deformation,  $\theta_{221}$  the gradient of relative deformation, and  $\kappa_{221}$  the local deformation gradient. Here  $( )_{,y}$  indicates partial differentiation with respect to  $y$ . Again following [5], we postulate the following strain energy function for the layered solid

$$\begin{aligned}
 W &= \frac{1}{2} c_1 e_{12}^2 + c_2 e_{12} \gamma_{21} + \frac{1}{2} c_3 \gamma_{21}^2 + \frac{1}{2} c_4 \kappa_{221}^2 + c_5 \kappa_{221} \theta_{221} + \frac{1}{2} c_6 \theta_{221}^2 \\
 &= \frac{1}{2} (c_1/4 + c_2 + c_3) u_{0,y}^2 - (c_2/2 + c_3) u_{0,y} \psi + \frac{1}{2} c_3 \psi^2 \\
 &\quad + \frac{1}{2} (c_4 - 2c_5 + c_6) \psi_{,y}^2 + (c_5 - c_6) u_{0,yy} \psi_{,y} + \frac{1}{2} c_6 u_{0,yy}^2
 \end{aligned}
 \tag{3}$$

Equation (3) is similar in a number of respects to the strain energy function postulated by Mindlin [2]; Eq. (3), however, includes some higher-order terms not considered by Mindlin and also omits several terms included in Mindlin's strain energy function.

We now set

$$\begin{aligned} a_1 &= c_1/4 + c_2 + c_3 ; & a_2 &= -c_6 ; & a_3 &= c_2/2 + c_3 ; \\ a_4 &= c_5 - c_6 & ; & a_5 &= c_3 & ; & a_6 &= -c_4 + 2c_5 - c_6 \end{aligned} \quad (4)$$

and rewrite (3) as

$$W = \frac{1}{2} a_1 u_{0,y}^2 - \frac{1}{2} a_2 u_{0,yy}^2 - a_3 u_{0,y} \psi + a_4 u_{0,yy} \psi_{,y} + \frac{1}{2} a_5 \psi^2 - \frac{1}{2} a_6 \psi_{,y}^2 . \quad (5)$$

The kinetic energy density is assumed to be given by

$$T = \frac{1}{2} b_1 \dot{u}_0^2 + \frac{1}{2} b_2 \dot{\psi}^2 . \quad (6)$$

Hamilton's principle may be written in the form

$$\delta \int_{t_0}^{t_1} \int_V (T - W) dV dt + \delta \int_{t_0}^{t_1} W_e dt = 0 . \quad (7)$$

Here  $V$  is the volume of the solid and  $W_e$  represents the work done by external forces. Body forces are assumed to be absent. Following [2], we take  $\delta W_e$  in the form

$$\delta W_e = \int_A \left[ (P_1 \delta u_0 + Q_1 \frac{\partial}{\partial y} \delta u_0 + M_1 \delta \psi)_{y=y_1} - (P_0 \delta u_0 + Q_0 \frac{\partial}{\partial y} \delta u_0 + M_0 \delta \psi)_{y=y_0} \right] dA \quad (8)$$

where  $A$  is a reference area measured in the planes  $y = y_0, y_1$ .

Substitution of (5), (6) and (8) into (7), followed by integration by parts, yields the equations of motion in the form

$$\begin{aligned} b_1 \ddot{u}_0 - a_1 u_{0,yy} - a_2 u_{0,yyyy} + a_3 \psi_{,y} + a_4 \psi_{,yyy} &= 0 \\ b_2 \ddot{\psi} - a_3 u_{0,y} - a_4 u_{0,yyy} + a_5 \psi + a_6 \psi_{,yy} &= 0 \end{aligned} \quad (9)$$

and the accompanying natural boundary conditions at  $y = y_0$  as

$$\begin{aligned} (-a_1 u_{0,y} + a_3 \psi - a_2 u_{0,yyy} + a_4 \psi_{,yy} + P_0) \delta u_0 &= 0, \\ (a_2 u_{0,yy} - a_4 \psi_{,y} + Q_0) \frac{\partial}{\partial y} \delta u_0 &= 0, \\ (-a_4 u_{0,yy} + a_6 \psi_{,y} + M_0) \delta \psi &= 0. \end{aligned} \quad (10)$$

A similar set of boundary conditions applies at  $y = y_1$ .

Equations (9) are identical in form to equations of motion for an elastic body with microstructure derived by Kunin [3] on the basis of an analysis of a generalized continuum model. These equations are considered by Kunin to represent the most general second-order approximation to the equations of motion of an elastic body with microstructure.

We now wish to consider the case of wave propagation in an unbounded

body. We thus assume harmonic solutions of the form

$$u_0 = Ae^{i(ky-\omega t)} ; \quad \psi = Be^{i(ky-\omega t)} . \quad (11)$$

Substitution into (9) leads to

$$\begin{aligned} (k^2 a_1 - k^4 a_2 - \omega^2 b_1) A + ik(a_3 - a_4 k^2) B &= 0 \\ - ik(a_3 - a_4 k^2) A + (a_5 - a_6 k^2 - \omega^2 b_2) B &= 0 . \end{aligned} \quad (12)$$

The requirement that the determinant of the system of Eqs. (12) must vanish then yields the dispersion equation in the form

$$\alpha \omega^4 + (\beta k^4 + \gamma k^2 + \delta) \omega^2 + \xi k^2 + \theta k^4 + k^6 = 0 , \quad (13)$$

where

$$\begin{aligned} \alpha &= \frac{b_1 b_2}{a_2 a_6 - a_4^2} ; \quad \beta = \frac{a_2 b_2}{a_2 a_6 - a_4^2} ; \quad \gamma = \frac{a_6 b_1 - a_1 b_2}{a_2 a_6 - a_4^2} \\ \delta &= \frac{-a_5 b_1}{a_2 a_6 - a_4^2} ; \quad \xi = \frac{a_1 a_5 - a_3^2}{a_2 a_6 - a_4^2} ; \quad \theta = \frac{2a_3 a_4 - a_1 a_6 - a_2 a_5}{a_2 a_6 - a_4^2} . \end{aligned} \quad (14)$$

In both the microstructural theories of Mindlin and Kunin, no prescription is given for determining the coefficients  $a_1, \dots, a_6, b_1, b_2$  in the equations of motion. It is to this question that we address ourselves in the succeeding sections.

### 3. DISPERSION SPECTRUM MATCHING

In the absence of analytical error estimates, the validity of an approximate solution in the theory of elasticity is often judged by applying the approximate theory to a problem for which an exact solution is known. The degree of agreement between exact and approximate solutions is then taken to give a reasonable estimate of the error inherent in the approximate theory.

This idea of error estimation by comparison between exact and approximate solutions supplies the rationale for the most important step in the construction of the effective dispersion theory. We will seek to minimize the error in the approximate solution by requiring the approximate dispersion spectrum to conform as closely as possible to the exact spectrum for wave propagation normal to the layering in an unbounded body. This requirement may be imposed in several different ways. One way, for example, would be to minimize the mean square difference between the two solutions. Here, however, we will make use of the simpler collocation method, where the approximate spectrum will be matched to the exact spectrum in ordinate and/or slope at a number of appropriate points. Specifically, we will require that

$$\left. \frac{d\omega}{dk} \right|_{\substack{\omega=0 \\ k=0}} = c_g ; \quad \omega \Big|_{k=k_B} = \omega_B ; \quad \omega \Big|_{k=k_B} = \omega_D$$

$$\left. \frac{d\omega}{dk} \right|_{\substack{\omega=\omega_B \\ k=k_B}} = 0 ; \quad \left. \frac{d\omega}{dk} \right|_{\substack{\omega=\omega_D \\ k=k_B}} = 0 . \quad (15)$$

Here  $c_g$ ,  $k_B$ ,  $\omega_B$  and  $\omega_D$  are defined in Fig. 2 and are parameters of the exact dispersion spectrum for propagation normal to the layering in an unbounded body. The equation defining the exact spectrum may be found in [4].

Upon introducing (13) into (15), we obtain five linear equations for the six parameters  $\alpha$ ,  $\beta$ ,  $\gamma$ ,  $\delta$ ,  $\xi$ , and  $\theta$ . The five equations serve to determine five of the parameters in terms of  $c_g$ ,  $\omega_B$ ,  $\omega_D$ , and  $k_B$ , and the remaining parameter, which we will take to be  $\theta$ . We obtain

$$\alpha = - \frac{k_B^4}{\omega_B^2 \omega_D^2} (\theta + 2k_B^2)$$

$$\beta = \frac{1}{k_B^2} \left[ \left( \frac{2}{c_g} + Rk_B^2 \right) \theta + \frac{3k_B^2}{c_g} + 2Rk_B^4 \right]$$

$$\delta = \frac{k_B^2}{c_g} (2\theta + 3k_B^2) \quad (16)$$

$$\xi = - k_B^2 (2\theta + 3k_B^2)$$

$$\gamma = - 2 \left[ \left( \frac{2}{c_g} + Rk_B^2 \right) \theta + \frac{3k_B^2}{c_g} + 2Rk_B^4 \right]$$

where

$$R = - \frac{(\omega_B^2 + \omega_D^2)}{\omega_B^2 \omega_D^2}$$

4. DETERMINATION OF  $\theta$ 

In order to completely determine the approximate dispersion spectrum (13), we must specify a value of  $\theta$ . To this end, we will first require that the approximate spectrum have real-valued frequencies for all values of wave number. This requirement insures the stability of the displacements (1), in that exponential growth of the displacements with time is not allowed. From (13),

$$\omega^2 = - \frac{(\beta k^4 + \gamma k^2 + \delta) \pm \sqrt{(\beta k^4 + \gamma k^2 + \delta)^2 - 4\alpha k^2 (\xi + \theta k^2 + k^4)}}{2\alpha} \quad (17)$$

From (17), necessary and sufficient conditions that  $\omega$  be real-valued are

$$(\beta k^4 + \gamma k^2 + \delta)^2 - 4\alpha k^2 (\xi + \theta k^2 + k^4) \geq 0 \quad (18)$$

and

$$\alpha (\xi + \theta k^2 + k^4) \geq 0 ; \quad - \frac{(\beta k^4 + \gamma k^2 + \delta)}{2\alpha} \geq 0 . \quad (19)$$

Examining the first of (19), substitution from (16) results in

$$(\theta + 2k_B^2) [k^4 + \theta k^2 - k_B^2 (2\theta + 3k_B^2)] \leq 0 . \quad (20)$$

Thus the two factors in (20) must be of opposite sign or vanish for all values of  $k$ . If we denote the second factor by

$$g(k) = k^4 + \theta k^2 - k_B^2 (2\theta + 3k_B^2) , \quad (21)$$

then the roots of  $g(k)$  are given by

$$k^2 = -\frac{\theta}{2} \pm \frac{1}{2} \sqrt{(\theta + 2k_B^2)(\theta + 6k_B^2)} . \quad (22)$$

Now  $g(k)$  will maintain the same sign for all values of  $k$ , or at most vanish at an isolated value of  $k$ , if it has only complex roots, or at most a double real root. From (22), this will be the case if

$$-6k_B^2 \leq \theta \leq -2k_B^2 . \quad (23)$$

However, from (16),  $\theta = -2k_B^2$  implies  $\alpha = 0$ , which results in a degenerate dispersion equation. Thus we reject this value and rewrite (23) as

$$-6k_B^2 \leq \theta < -2k_B^2 . \quad (24)$$

Then for values of  $\theta$  satisfying (24),  $g(k)$  can be seen to be positive, or zero for all real values of  $k$ , while the first factor in (20) is negative, thus satisfying the inequality.

We now consider the second of (19). Since  $\alpha > 0$  for  $\theta$  in the range (24), the second of (19) implies that

$$\beta k^4 + \gamma k^2 + \delta \leq 0 . \quad (25)$$

Now  $\delta < 0$  if (24) is satisfied, so the inequality (25) will be satisfied for all values of  $k$  if and only if the biquadratic expression  $\beta k^4 + \gamma k^2 + \delta = 0$  has no real roots, or at most a double real root. This requirement implies that the discriminant must satisfy the inequality

$$\gamma^2 - 4\beta\delta \leq 0 . \quad (26)$$

If we set  $\theta = -ck_B^2$ , where

$$2 < c \leq 6 \quad (27)$$

from (24) and substitute from (16), (26) becomes

$$f(c, Rk_B^2 c_g^2) \equiv (2 - c) Rk_B^2 c_g^2 + (3 - 2c) \leq 0 \quad (28)$$

where we note that  $Rk_B^2 c_g^2 < 0$ . The region of common validity of the inequalities (28) and (27) is shown as the hatched area in Fig. 3. It is apparent from the figure that we can always pick a value of  $c$  so as to satisfy both (27) and (28). We note in addition that for  $Rc_g^2 k_B^2 < -\frac{9}{4}$ , (28) represents a more severe restriction on the upper limit of  $c$  than does (27).

We now examine Eq. (18), which may be written as

$$\begin{aligned} h(k) \equiv & \beta^2 k^8 + (28\gamma - 4\alpha) k^6 + (\gamma^2 + 2\beta\delta - 4\alpha\theta) k^4 \\ & + (2\gamma\delta - 4\alpha\xi) k^2 + \delta^2 \geq 0 \end{aligned} \quad (29)$$

$h(k)$  is a fourth-order polynomial in  $k^2$ , whose coefficients are functions of the parameter  $\theta$  through (16). Since  $h(0) = \delta^2 \geq 0$ , it is apparent that a necessary and sufficient condition that (29) hold for all values of  $k$  is that  $h(k)$  have no real roots, or at most double real roots.

Due to the complexity of  $h(k)$ , numerical analysis is required to determine whether or not there exist values of  $\theta$  such that  $h(k)$  has no real roots, or double real roots, and such that (24) and (28) are satisfied. If this is the case, then for these values of  $\theta$ , the dispersion equation (13) will yield only real frequencies and thus guarantee stable displacements.

To complete the determination of the parameter  $\theta$ , we now consider the question of inverting equations (14) to determine the coefficients of the equations of motion in terms of the six parameters  $\alpha$ ,  $\beta$ ,  $\gamma$ ,  $\delta$ ,  $\xi$ , and  $\theta$ . Since the equations of motion are homogeneous, one of the coefficients may be fixed arbitrarily. We will take this coefficient to be  $a_6$  and normalize the remaining seven coefficients with respect to  $a_6$ . The inversion procedure then yields

$$\frac{a_1}{a_6} = - \left( \frac{a_2}{a_6} \right) \left( \frac{\delta}{\beta} \frac{a_6}{a_5} + \frac{\gamma}{\beta} \right)$$

$$\frac{a_3}{a_6} = \pm \left( \frac{a_2}{a_6} \right)^{\frac{1}{2}} \left[ \left( \frac{\alpha\xi}{\beta\delta} - \frac{\gamma}{\beta} \right) \frac{a_5}{a_6} - \frac{\delta}{\beta} \right]^{\frac{1}{2}}$$

$$\frac{a_4}{a_6} = \pm \left( \frac{a_2}{a_6} \right)^{\frac{1}{2}} \left( 1 + \frac{\alpha}{3\delta} \frac{a_5}{a_6} \right)^{\frac{1}{2}} \quad (30)$$

$$\frac{b_1}{a_6} = \frac{a_2}{a_6} \frac{\alpha}{\beta}$$

$$\frac{b_2}{a_6} = - \frac{\alpha}{\delta} \frac{a_5}{a_6}$$

where the ratio  $a_5/a_6$  is a root of

$$\left(\frac{\alpha\theta}{\beta\delta} - 1\right)\left(\frac{a_5}{a_6}\right)^2 + \frac{\gamma}{\beta}\left(\frac{a_5}{a_6}\right) + \frac{\delta}{\beta} \pm 2\left(\frac{a_5}{a_6}\right)\left(1 + \frac{\alpha}{\beta\delta}\frac{a_5}{a_6}\right)^{\frac{1}{2}} \\ \times \left[\left(\frac{\alpha\xi}{\beta\delta} - \frac{\gamma}{\beta}\right)\frac{a_5}{a_6} - \frac{\delta}{\beta}\right]^{\frac{1}{2}} = 0 \quad (31)$$

The positive sign in the last term in (31) is to be taken when  $a_3$  and  $a_4$  are of the same sign, and the negative sign when they are of the opposite sign. The ratio  $a_2/a_6$  is left as yet undetermined.

Since  $\theta$  is not completely determined by the requirement that the frequencies in the approximate spectrum be real, we now seek to obtain a value of  $\theta$  which, besides yielding real frequencies, also gives real roots for  $a_5/a_6$  in (31). Although there seems to be no *a priori* requirement that  $a_5/a_6$ , or any of the other coefficients in the equations of motion, be real, the imposition of this requirement will simplify the resulting theory. Also, it will permit the determination of a unique value of  $\theta$ , as will shortly be demonstrated.

Squaring (31), we obtain the following fourth-order polynomial in  $a_5/a_6$

$$\left[\left(\frac{\alpha\theta}{\beta\delta} - 1\right)^2 - 4\frac{\alpha}{\beta\delta}\left(\frac{\alpha\xi}{\beta\delta} - \frac{\gamma}{\beta}\right)\right]\left(\frac{a_5}{a_6}\right)^4 + \left[2\frac{\gamma}{\beta}\left(\frac{\alpha\theta}{\beta\delta} - 1\right) - 4\left(\frac{\alpha\xi}{\beta\delta} - \frac{\gamma}{\beta}\right) + 4\frac{\alpha}{\beta^2}\right] \\ \times \left(\frac{a_5}{a_6}\right)^3 + \left[\frac{\gamma^2}{\beta^2} + 2\frac{\delta}{\beta}\left(\frac{\alpha\theta}{\beta\delta} - 1\right) + 4\frac{\delta}{\beta}\right]\left(\frac{a_5}{a_6}\right)^2 + 2\frac{\gamma\delta}{\beta^2}\left(\frac{a_5}{a_6}\right) + \frac{\delta^2}{\beta^2} = 0 \quad (32)$$

where the coefficients are functions of the parameter  $\theta$ . Due to its complexity, the roots of (32) must be analyzed numerically. When this is done,

a rather surprising fact emerges, namely, that (32) and  $h(k)$  as defined by (29) both exhibit a double real root for the same value of  $\theta$ . Furthermore, for values of  $\theta$  greater than this value, (32) and  $h(k)$  both have distinct real roots, while for values less than this value, they have no real roots.

The condition on the coefficients of a polynomial such that the polynomial has double real roots may be determined from the theory of eliminants [6]. For a fourth-order polynomial of the form  $a_0x^4 + a_1x^3 + a_2x^2 + a_3x + a_4 = 0$ , the criterion for double roots may be expressed as

$$\begin{vmatrix} (3a_1^2 - 8a_0a_2) & (2a_1a_2 - 12a_0a_3) & (a_1a_3 - 16a_0a_4) \\ (2a_1a_2 - 12a_0a_3) & (4a_2^2 - 8a_1a_3 - 16a_0a_4) & (2a_2a_3 - 12a_1a_4) \\ (a_1a_3 - 16a_0a_4) & (2a_2a_3 - 12a_1a_4) & (3a_3^2 - 8a_2a_4) \end{vmatrix} = 0 \quad (33)$$

Equation (33), when applied to (32) and  $h(k)$ , becomes too complex to be treated analytically, and must be evaluated numerically. This was done for several different sets of values of  $\omega_B$ ,  $\omega_D$ ,  $c_g$ , and  $k_B$ . In every case the same value of  $\theta$  produced a double real root for both  $h(k)$  and (32). It is thus concluded that this behavior is not coincidental.

We now see that  $\theta$  may be determined uniquely as that value which yields double real roots for  $h(k)$  and (32), thus satisfying simultaneously the inequality (29) and the condition that  $a_5/a_6$  be real. Furthermore, the quantity  $a_5/a_6$  will be determined uniquely as well. The ambiguity in the signs of  $a_3$  and  $a_4$  may be resolved by numerically determining whether the positive or negative sign must be taken in the last term of (31) in order that the double real root  $a_5/a_6$  satisfy (31). Of course, the remaining two roots of  $h(k)$  must be complex to insure real frequencies. Numerical analysis is required to test the satisfaction of this requirement.

Once  $\theta$  is determined, the approximate dispersion spectrum is completely specified. As a numerical example, we take  $\mu/\mu' = 0.02$ ,  $\mu\rho'/\mu'\rho = 0.06$  and  $h'/h = 4$ , and introduce a nondimensional frequency and wave number defined by  $\Omega = 2h\omega/(\pi\sqrt{\mu/\rho})$  and  $\eta = (2h/\pi)k$ . For these values, the exact solution [4] yields  $\Omega_B \equiv 2h\omega_B/(\pi\sqrt{\mu/\rho}) = 0.179005$ ,  $\Omega_D = 0.831029$ ,  $c_g \equiv (d\Omega/d\eta)|_{\eta=0} = 1.334401$ , and  $\eta_B \equiv (2h/\pi)k_B = 0.20$ . We now apply the matching procedure with these nondimensional parameters. The value of  $\theta$  which yields double real roots for  $h(k)$  and (32) is found to be  $\theta = -0.156317 = -3.90793\eta_B^2$ , which satisfies (24). The remaining pair of roots of  $h(k)$  is found to be a complex conjugate pair. Also,  $Re c_g^2 \eta_B^2 = -2.32594$ , satisfying (28).

The resulting spectrum is compared to the exact spectrum for shear waves propagating normal to the layering in Figs. 4 and 5. Figure 4 shows the exact and approximate spectra over the first two Brillouin zones for real values of the wave number  $\eta$ , plotted on the periodic zone scheme. Since only waves with non-negative group velocity are to be considered, only the acoustic branch in the first Brillouin zone and the optical branch in the second Brillouin zone are of interest. It can be seen that the approximate spectrum agrees extremely well with the exact solution. The spectrum of a typical existing approximate theory, the effective stiffness theory [5], is shown for comparison. It is seen that the effective dispersion theory yields a substantial improvement in accuracy. Figure 5 shows the exact and approximate complex branches connecting the acoustic and optical branches. Here again the agreement between the two solutions is quite good.

In passing, it should be noted that the requirement that  $h(k)$  have a double real root implies that the optical and acoustic branches of the approximate spectrum will touch at a point. For the parameters used in the numerical example, this point lies in the third Brillouin zone.

### 5. MATCHING OF MODE SHAPES

We now seek to determine the quantity  $a_2/a_6$  by imposing the requirement that the approximate mode shape match the exact mode shape as closely as possible at the right-hand end of the first Brillouin zone.

In order to compute the approximate mode shapes, we arbitrarily assume the global coordinate system to have its origin at the midplane of the layer with primed constants in the zeroth unit cell. Using this scheme, the midplane of the layer with primed constants within the N-th unit cell is located at

$$y = 2N(h + h') \quad (34a)$$

while the midplane of the layer with unprimed constants is located at

$$y = (1 + 2N)(h + h') \quad (34b)$$

Thus, introducing (11) into (1) and making use of the nondimensional variables defined in the previous section, the approximate displacement mode shapes (1) take the form

$$\frac{u}{A} = \left[ 1 + \left( \frac{Bh}{A} \right) \frac{Y_N}{h} \right] e^{i(2N+1)(1+\epsilon)\pi\eta/2}$$

$$\frac{u'}{A} = e^{iN(1+\epsilon)\pi\eta} \quad (35)$$

Since we are using complex notation, it is implicitly understood that only the real part of (35) will be of significance. Here the time variation has

been omitted, and  $N = 0, \pm 1, \pm 2, \dots$ . It may be seen immediately that the displacements defined by (35) have the same periodicity as the exact solution at the end of the first Brillouin zone where  $\eta_B = \frac{2hk_B}{\pi} = \frac{1}{1+\epsilon}$ , i.e., periodic with a period of two unit cells.

The ratio  $(Bh/A)$  may be determined from the first of (12), which gives

$$\frac{Bh}{A} = i \left( \frac{\eta^2 a_1 - \eta^4 a_2 - \Omega^2 b_1}{\eta a_3 - \eta^3 a_4} \right) \quad (36)$$

where the constants involved in the nondimensionalization procedure are assumed to have been absorbed into the parameters  $a_1, \dots, b_1$ . We now write  $(Bh/A) = iC$ , and evaluate the displacements (35) at  $\eta = \eta_B$ .

We obtain

$$\operatorname{Re} \left( \frac{u}{A} \right) \Big|_{\eta=\eta_B} = -(-1)^N C \frac{y_N}{h}$$

$$\operatorname{Re} \left( \frac{u'}{A} \right) \Big|_{\eta=\eta_B} = (-1)^N. \quad (37)$$

For the parameters used in the numerical example in the previous section, the displacement corresponding to the exact solution is symmetric about the layer midplanes in the layers with primed constants and antisymmetric in the layers with unprimed constants. This pattern of symmetry can be seen to be realized in the approximate displacements (37). If we now require continuity of displacement at the interface of the  $N$ -th unit cell, where  $y_N/h = -1$ , we obtain

$$C = 1 .$$

(38)

Using (36), (38), and (30), we may solve for the required value of  $a_2/a_6$ , which is

$$\frac{a_2}{a_6} = \left\{ \frac{\eta_B \left[ \left( \frac{\alpha\xi}{\beta\delta} - \frac{\gamma}{\beta} \right) \frac{a_5}{a_6} - \frac{\delta}{\beta} \right]^{\frac{1}{2}} \pm \eta_B^3 \left( 1 + \frac{\alpha}{\beta\delta} \frac{a_5}{a_6} \right)^{\frac{1}{2}}}{\eta_B^2 \left( \frac{\delta}{\beta} \frac{a_6}{a_5} + \frac{\gamma}{\beta} \right) + \eta_B^4 + \Omega_B^2 \frac{\alpha}{\beta}} \right\}^2 \quad (39)$$

The quantity  $a_5/a_6$  is determined in the previous section. The positive sign is taken in the second term of the numerator of (40) if  $a_3$  and  $a_4$  are taken to be of opposite sign, while the negative sign is taken if  $a_3$  and  $a_4$  are of the same sign.

The exact and approximate displacement mode shapes at the right-hand end of the first Brillouin zone are sketched in Fig. 6 for  $a_2/a_6$  defined by (39). The exact mode shapes are taken from [7]. Here  $l$  and  $l'$  are local coordinates having their origins at the midplanes of the layers with unprimed and primed constants, respectively, and being normalized by the layer thickness. The agreement between exact and approximate mode shapes in Fig. 6 can be seen to be excellent. Figure 7 shows the exact and approximate mode shapes at two points in the interior of the first Brillouin zone. Here the agreement is not as good as at the zone end. This is not surprising in view of the fact that the exact displacements are in general quasi-periodic, as discussed in [7], while the approximate displacements given by (1) and (11) are strictly periodic. Also, continuity of displacement at the layer interfaces in the effective dispersion theory is only approximate, as may be noted from the figure.

## 6. DISCUSSION AND CONCLUSIONS

As mentioned earlier, there exist in the literature a number of approximate theories for wave propagation in a layered composite of the type considered in this work. For the case of wave propagation normal to the layering, these theories are generally limited in validity to regions in the interior of the first Brillouin zone. The ability to model this region of the spectrum accurately is certainly the most important consideration for stress analysis ; however, it seems likely that the stopping band between the first and second Brillouin zones may also play a significant role in some practical problems. The effective dispersion theory outlined in this paper is the only existing approximate theory which has been shown to contain this stopping band. In addition, the effective dispersion theory is more accurate than most other approximate theories over the first Brillouin zone. It is quite accurate as well over the second Brillouin zone, a region which other approximate theories have not attempted to model. For these reasons, the effective dispersion theory is thought to represent a significant advance in the construction of approximate theories for wave propagation in layered solids.

The effective dispersion theory is subject to one limitation, however, in that there seems to be no guarantee that a value of  $\theta$  can be found so that inequalities (24), (28), and (29) are simultaneously satisfied. It appears that these inequalities must be individually tested for each set of material and geometric parameters under consideration, and that no definite general statement can be made as to the range of applicability of the effective dispersion theory.

On the other hand, the numerical example presented in this paper

was chosen to represent a typical composite material, and here it was shown that it was possible to satisfy all the relevant inequalities. It therefore seems likely that the effective dispersion theory will be applicable to the analysis of a number of classes of composite materials of practical interest.

In closing, we will briefly discuss two areas where further effort is required to refine the effective dispersion theory. The first of these is the question of uniqueness of solution. It has been shown in [5] that uniqueness of solution follows from the positive definiteness of the strain and kinetic energy densities. More recently, Edelman [8] has proved uniqueness of solution for microstructural theories of the Mindlin type if the strain energy density is homogeneous of order two and if the coefficients in the kinetic energy density expression,  $b_1$  and  $b_2$ , are of the same sign. Unfortunately, because the effective dispersion theory places primary emphasis upon matching procedures, it is not possible to satisfy these conditions. Thus, the question of uniqueness of solution remains an open one.

One rather general criterion for uniqueness may be stated immediately however. It has been shown [9] that stability in the sense of Liapunov represents a necessary and sufficient condition for uniqueness of solution in dynamic systems. Thus, if a Liapunov-stable solution can be found to equations (9), subject to the boundary conditions (10) and an appropriate set of initial conditions, the uniqueness of the solution is insured.

The second area requiring further effort concerns the boundary conditions (10). At the present time we are unable to give a prescription for calculating the boundary forces  $P$ ,  $Q$ , and  $M$  for a pure

traction boundary value problem. This difficulty seems to be common to theories of the microstructural type and represents an impediment to the solution of realistic boundary-initial value problems. The most obvious method for treating a traction boundary value problem, setting  $P$  equal to the applied traction and  $Q = M = 0$ , appears to be somewhat questionable here, since setting  $Q = M = 0$  in equations (10) leads to  $u_{0,yy} = \psi_{,y} = 0$  at the bounding surface. These conditions seem to be unnecessarily restrictive. It is, of course, possible to formulate and solve boundary value problems of the mixed variety, but these are seldom of practical interest. The resolution of this question must at the present time await further study.

#### ACKNOWLEDGMENT

The authors gratefully acknowledge many helpful discussions with Professor Raj K. Kaul of the State University of New York at Buffalo.

This research was supported in part by the Office of Naval Research Contract N00014-76-C-0054 to Stanford University.

REFERENCES

1. Herrmann, G., Kaul, R.K. and Delph, T.J., "On Continuum Modeling of the Dynamic Behavior of Layered Composites", *Archives of Mechanics (Archiwum Mechaniki Stosowanej)* 28, 3, pp. 405-421, Warszawa (1976).
2. Mindlin, R.D., "Microstructure in Linear Elasticity", *Arch. Rat. Mech. Anal.* 16, 51-78 (1964).
3. Kunin, I.A., "Theory of Elasticity with Spatial Dispersion: One-Dimensional Complex Structure", *PMM* 30, 866-874 (1966)
4. Lee, E.H. and Yang, W.H., "On Waves in Composite Materials with Periodic Structure", *SIAM Journal of Applied Mathematics*, 25, 492-499 (1973).
5. Achenbach, J.D., Sun, C.-T. and Herrmann, G. "On the Vibrations of a Laminated Body", *J. Appl. Mech.* 35, 689-696 (1968).
6. Littlewood, D.E., *A University Algebra*, Dover Publications, New York (1970).
7. Delph, T.J., Herrmann, G., and Kaul, R.K. "Harmonic Wave Propagation in a Periodically Layered, Infinite Elastic Body: Antiplane Strain", *J. Appl. Mech.* 45, 343-349 (1978).
3. Edelman, W.S., "A Uniqueness Theorem in the Linear Theory of Elasticity with Microstructure", *Acta Mechanica* 8, 183-187 (1969).
9. Gilbert, J.E. and Knops, R.J., "Stability of General Systems", *Arch. Rat. Mech. Anal.* 25, 271-284 (1967).

FIGURE CAPTIONS

- Fig. 1 Geometry of layered elastic solid
- Fig. 2 Parameters of exact dispersion spectrum used in effective dispersion theory.
- Fig. 3 Region of common validity of inequalities (27) and (28).
- Fig. 4 Spectrum of effective dispersion theory over the first two Brillouin zones (real branches).
- Fig. 5 Complex branch between the first two Brillouin zones.
- Fig. 6 Effective dispersion mode shapes and exact mode shapes at the right-hand end of the first Brillouin zone.
- Fig. 7 Effective dispersion mode shapes and exact mode shapes at two points in the interior of the first Brillouin zone.

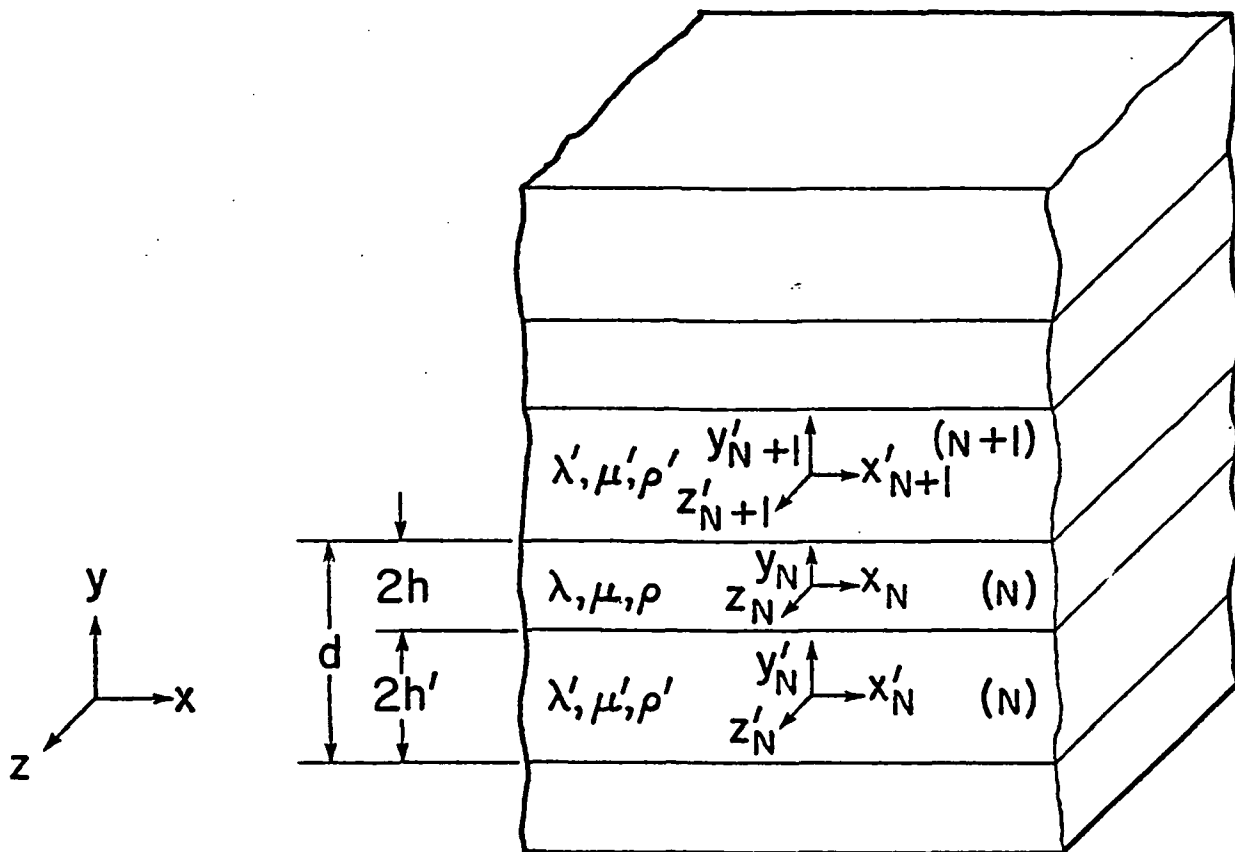

Figure 1

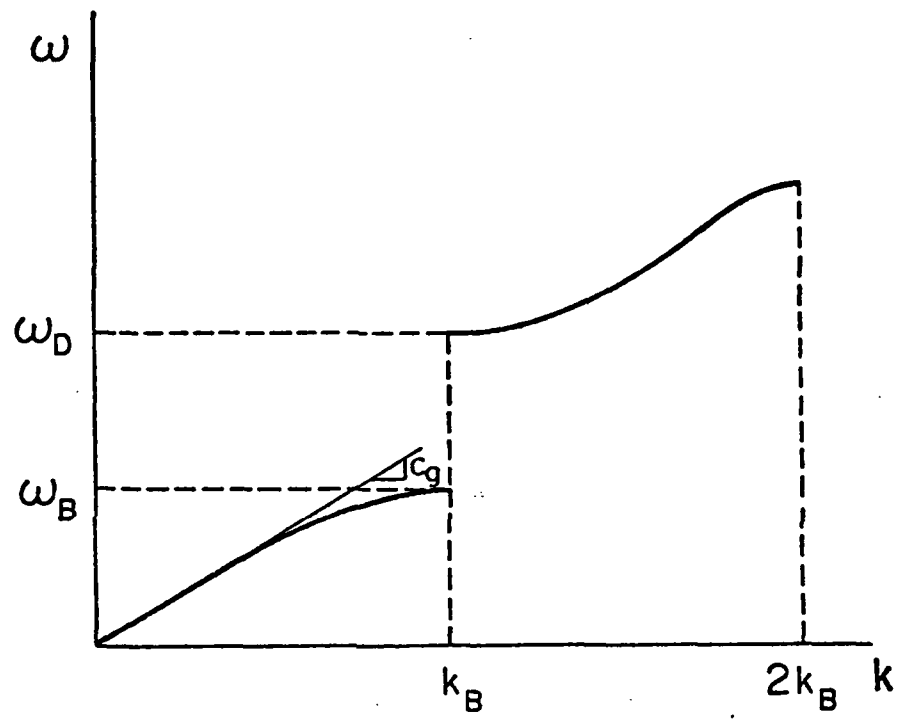

Figure 2

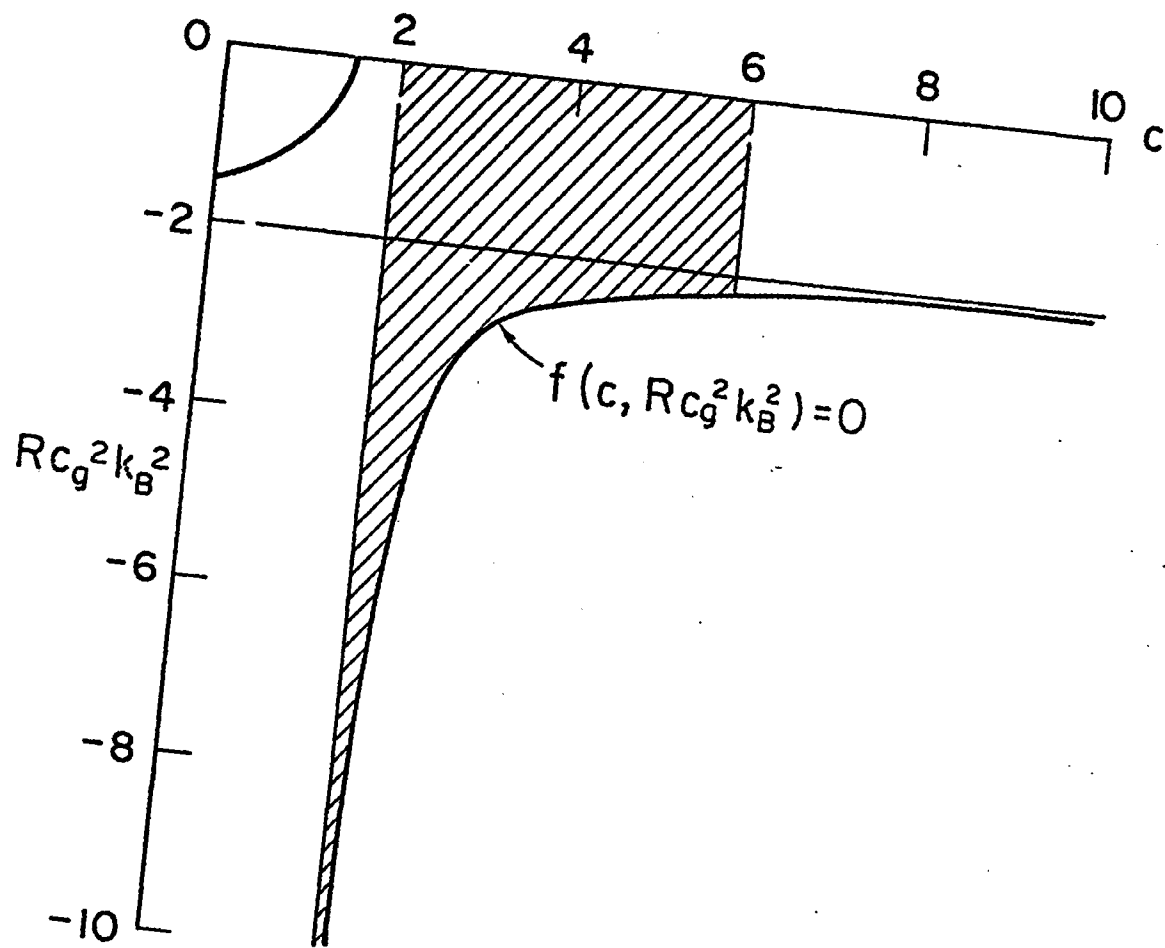

Figure 3

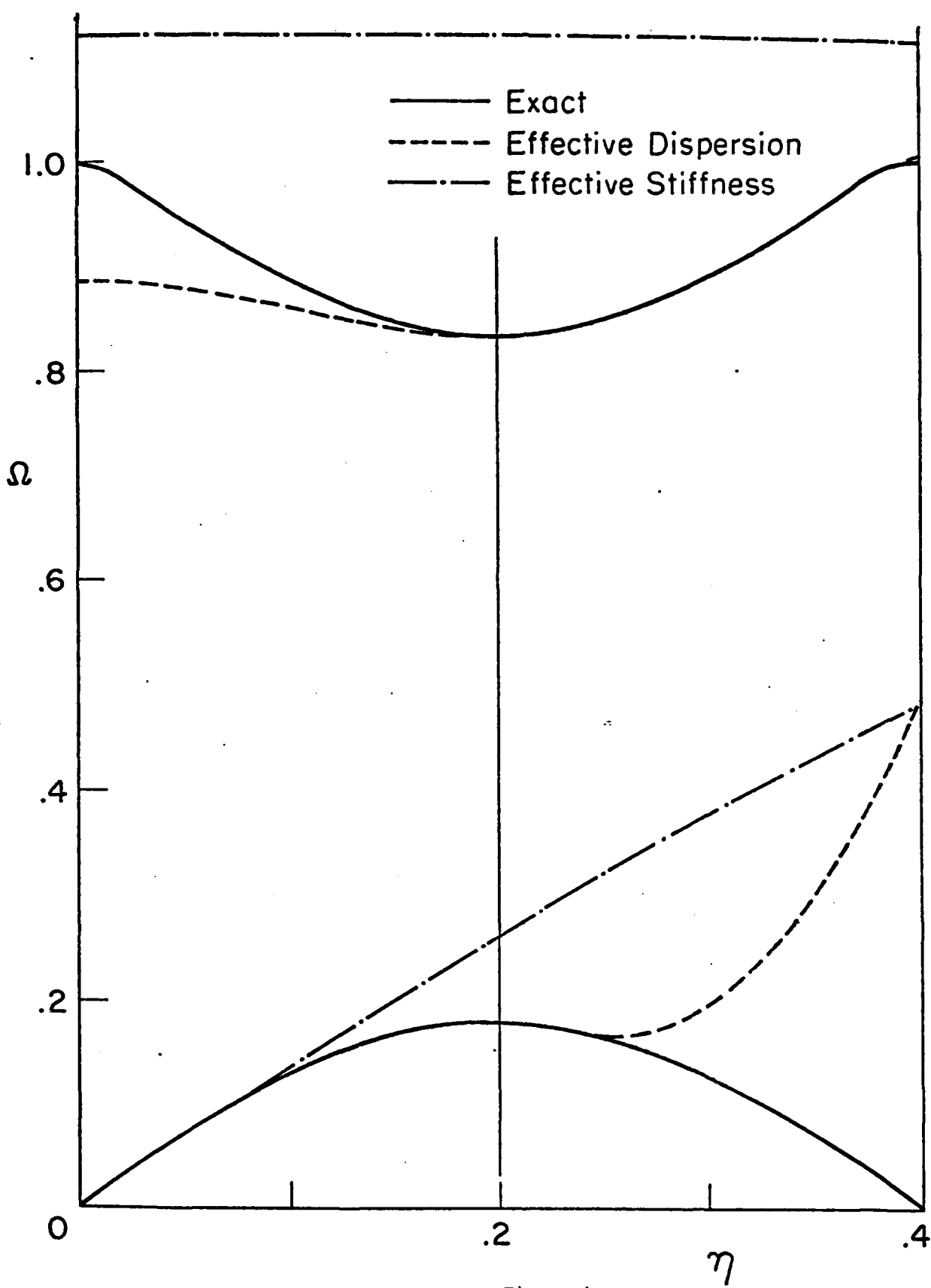

Figure 4

— Exact  
- - - Approx

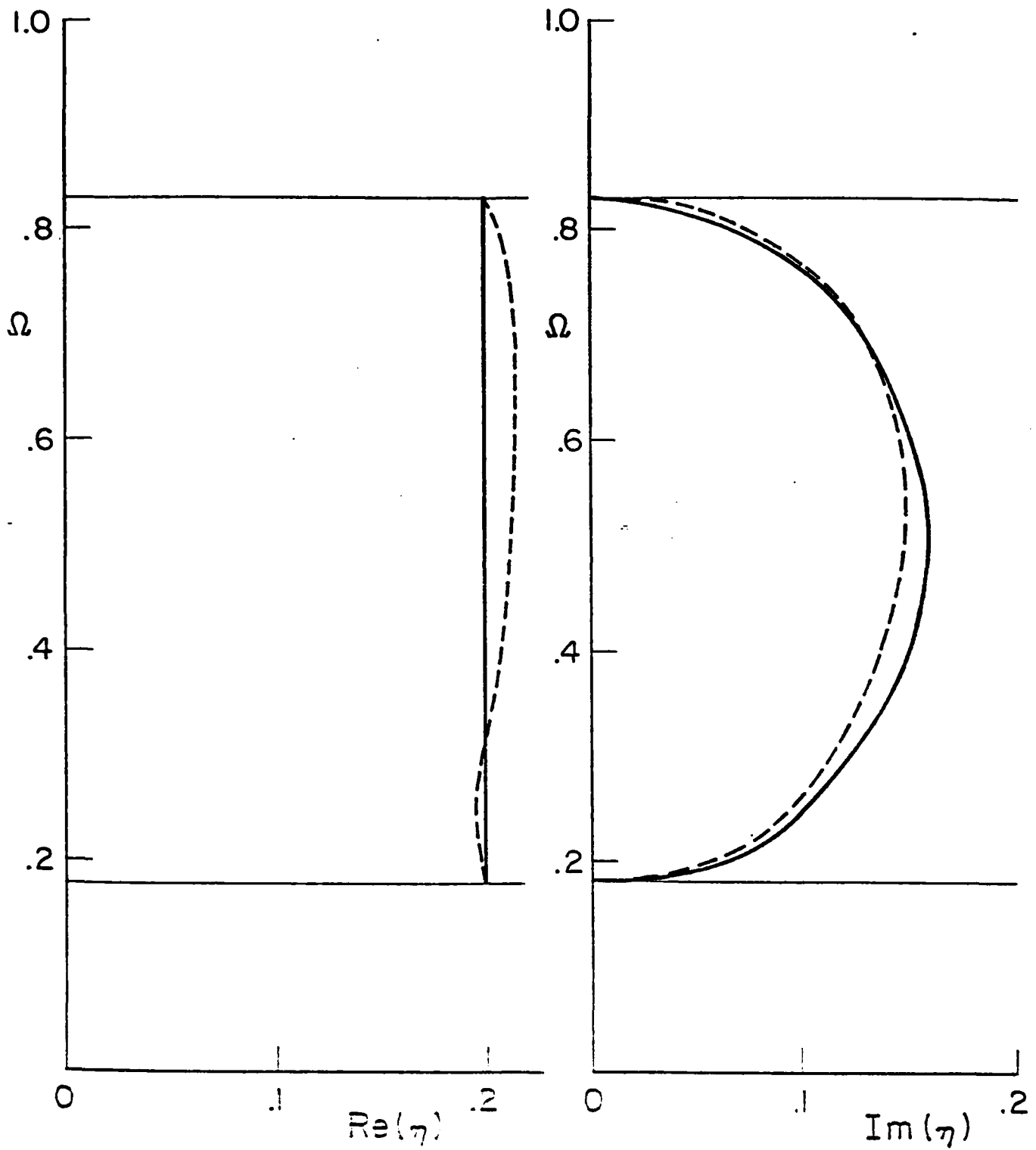

Figure 5

———— EXACT      - - - - - APPROX.

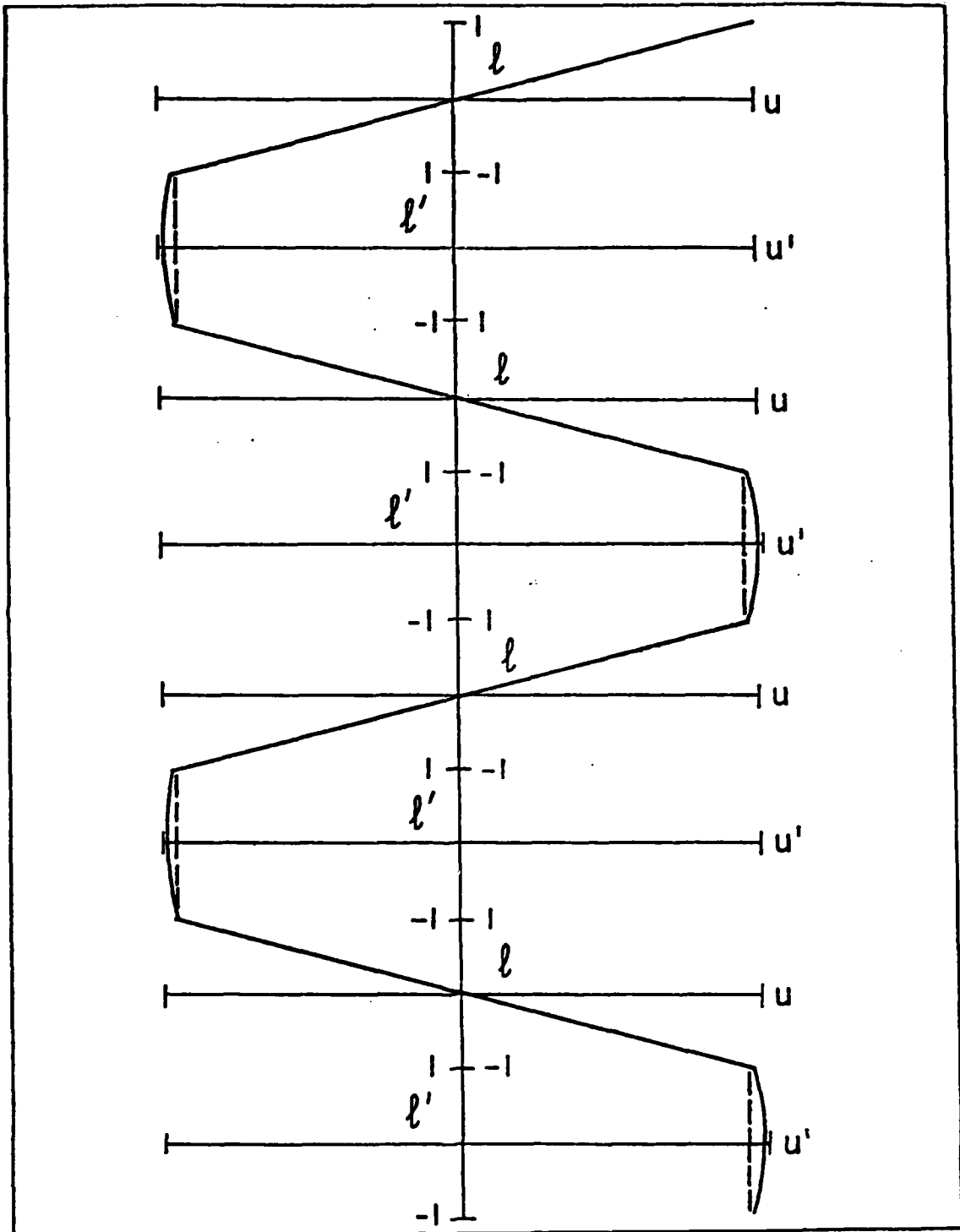

Figure 6

— Exact  
 - - - - - Approx.

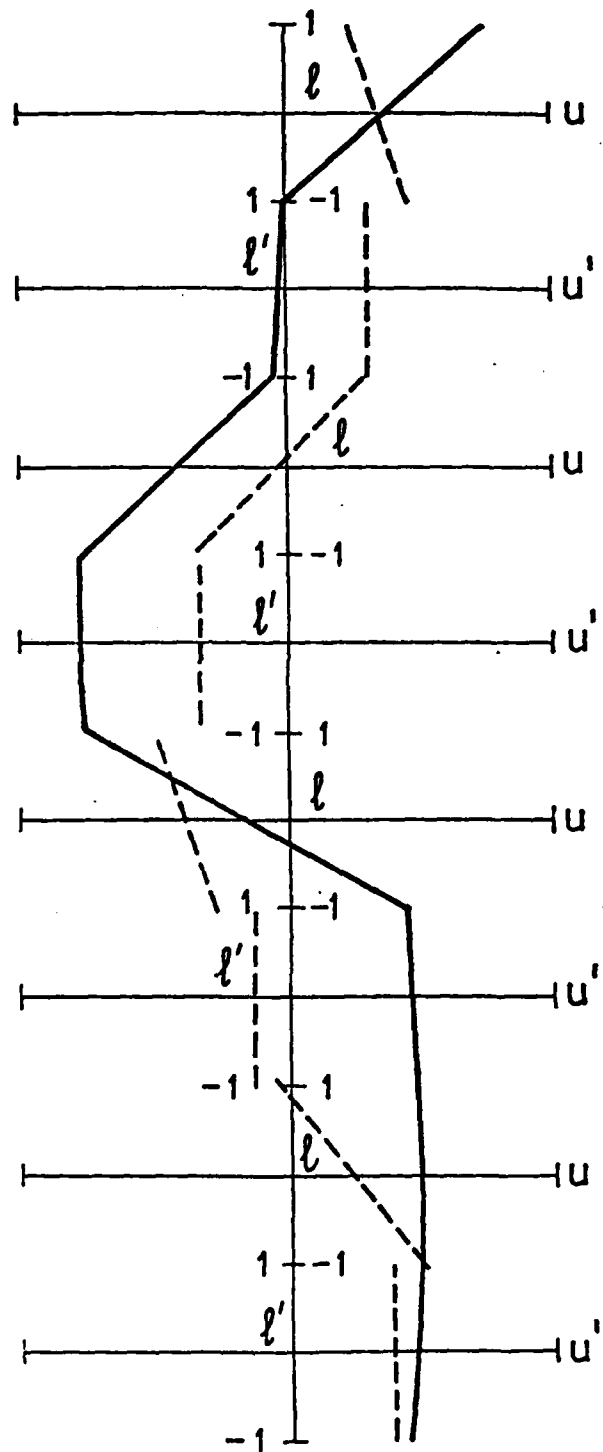
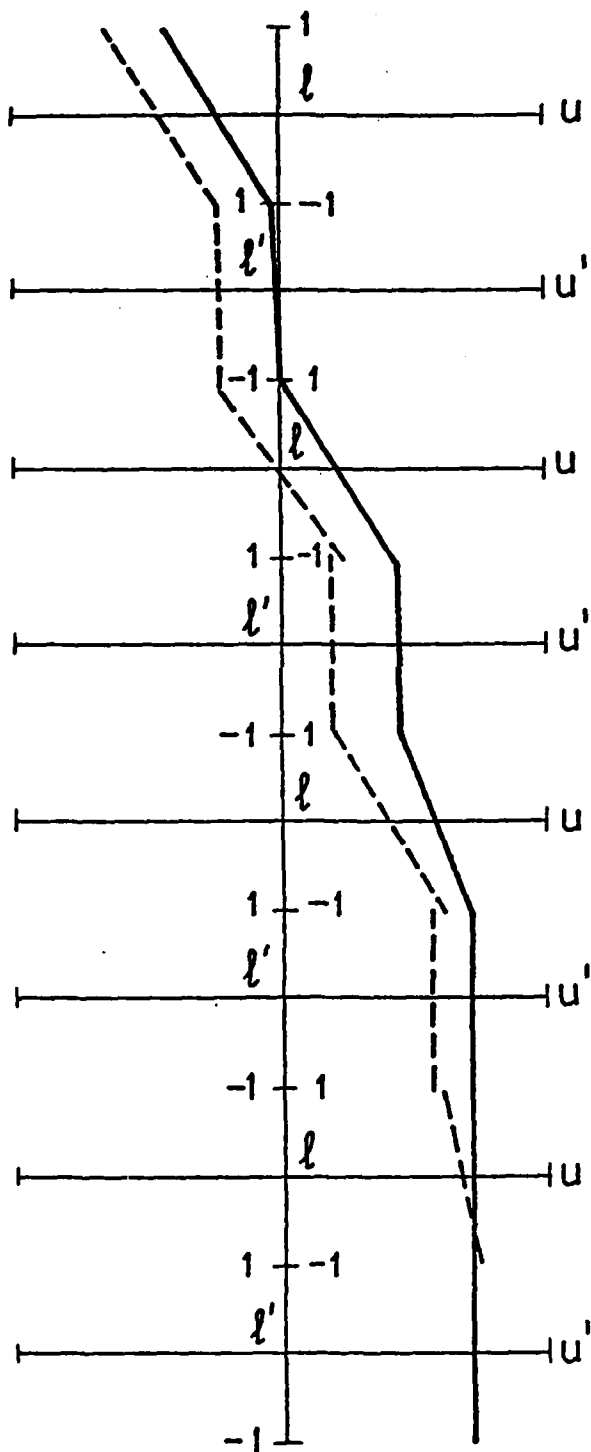

Figure 7

