

AD-A095 291

FOREIGN TECHNOLOGY DIV WRIGHT-PATTERSON AFB OH  
TRANSIT TELEPHONE EXCHANGE METACONTA 10C.(U)

F/G 17/2

UNCLASSIFIED

DEC 80 M UNK  
FTO-ID(RS)T-1214-80

NL

1 of 1  
AC-  
ADVISORY

11

END  
DATE  
FILMED  
3 81  
DTIC

②  
10.5

AD A09529 I

# FOREIGN TECHNOLOGY DIVISION



TRANSIT TELEPHONE EXCHANGE METACONTA 10C

by

Miha Unk

DTIC  
ELECTE  
FEB 20 1981  
E

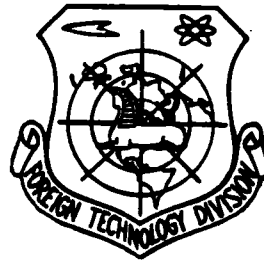

Approved for public release;  
distribution unlimited.

BBC FILE COPY



012 18 083

12-18

# EDITED TRANSLATION

11/ FTD-ID(RS)T-1214-80 // 10 Dec 1980

MICROFICHE NR: FTD-80-C-001224

TRANSIT TELEPHONE EXCHANGE METACONTA 10C,

By: Miha/Unk

English pages: 16

Source: Elektrotehniski Vestnik, Vol. 41, Nr. 3-4,  
1974, pp. ~~27-32~~

Country of origin: Yugoslavia

Translated by: LINGUISTIC SYSTEMS, INC.

F33657-78-D-0618

Nenad Popovic

Requester: FTD/TQCS

Approved for public release; distribution  
unlimited.

THIS TRANSLATION IS A RENDITION OF THE ORIGINAL FOREIGN TEXT WITHOUT ANY ANALYTICAL OR EDITORIAL COMMENT. STATEMENTS OR THEORIES ADVOCATED OR IMPLIED ARE THOSE OF THE SOURCE AND DO NOT NECESSARILY REFLECT THE POSITION OR OPINION OF THE FOREIGN TECHNOLOGY DIVISION.

PREPARED BY:

TRANSLATION DIVISION  
FOREIGN TECHNOLOGY DIVISION  
WP.AFB, OHIO.

Iskra Technical Reports  
Year XVI-1974-2

TRANSIT TELEPHONE EXCHANGE METACONTA 10C  
(Tranzitna centrala sistema metaconta 10 C)

by

Miha Unk, Kranj

UDK 621.395.2

(Received March 20, 1974)

Transit telephone exchange of the type Metaconta 10 C is a stored program controlled telephone exchange with reed relays in switching network. The exchange is controlled by ITT 3200 processor, developed especially for application in telephone exchanges, The Exchange is very flexible due to teh SPC concept. Reed relays enable fast switching and high quality mechanical contact which is not influenced by the atmosphere. The exchange can be extended easily not interfering with normal operation of the exchange.

Accession For		
NTIS GRA&I	<input checked="" type="checkbox"/>	
DTIC TAB	<input type="checkbox"/>	
Unannounced	<input type="checkbox"/>	
Justification		
By _____		
Distribution/ _____		
Availability Codes		
Dist and/or		
Dist	Special	
A		

## 1. Introduction

The system of the Metaconta 10 C telephone exchange represents a new generation of telephone exchanges which are based on contemporary technology and which use fast programmed computers. The system has two types of computers, the ITT 1600 and the ITT 3200 at its disposition. The former is appropriate for exchanges of smaller capacities, while the latter can, if necessary, be used in multi-computer configurations, and is capable of controlling the largest local, transit and international telephone exchanges. In this, as well as in a number of other reports, it is our intention to describe a transit telephone exchange. This introductory report is going to emphasize the main characteristics of transit exchanges and how it is built. Other forthcoming reports will concentrate in greater detail on particular areas. They will also offer information on building telephone exchanges, their computers, and software engineering.

## 2. The Main Characteristic of a Transit Telephone Exchange.

The typical characteristics of transit telephone exchanges, as well as other exchanges of the Metaconta 10 C type, are the following:

- Centralized control with computers and stored programs.
- Reed relays and also electronic elements, such as transistors, diodes, resistors, integrated circuits, ferrite materials, etc., are utilized in the switching multiplex.

This is the basis of the exchange's adaptability and flexibility, which is very important since the adaptability is the most fundamental requirement for the development of modern switching systems. The adaptability is due to the program control concept which enables the simple execution of changes and modifications of the entire programming package. It is also convenient for the introduction of new functions and capabilities. All of these features, in their turn, greatly contribute to the further quick development of this technology. Because a majority of logical decisions are based on the stored programs, the operation of the transmitters is much simplified. The same is true for receivers and senders, whose role anyway is to transform signals into a form convenient for further computer processing. Great possibilities are being opened for setting a traffic strategy, all in order to achieve maximal exploitation of large and small sheaves. Various strategies are indicated for alternate traffic directions. New roads for the adoption of improved signalization principles (as for example the signalization no. 6, etc.) are being opened by means of programs and of high speed operations.

The switching multiplex is made of hermetically sealed reed relays. These relays are made of two miniature metallic slices, which are welded into small glass tubing filled with gas. The relay establishes the contact under the influence of a magnetic field, which we create with the corresponding electrical flows through the coil, within which the relays are located. We thus have a connection and a high quality contact, which is uninfluenced by the outside atmosphere. Relays can be controlled relatively fast, which results in establishing the connection in a very short time. In addition, in the switching multiplex, contacts could be set to "on" or "off", without overloading electrical flows. This feature gives to relays a very long and useful life.

Since they are of extremely small size, they take up little space. They are usually mounted on plates with printed circuits. We thus achieve significant savings in space. It further contributes to the small size of the basic matrices, enabling the executions of optimal adaptations within the multiplex in order to meet requirements determined by the traffic. All other elements are mounted on the plates, of the same size, with printed circuits. Thus we obtain a uniform mechanic construction which is standardized for all telephone exchanges of the M-10-C system.

Before they are built into telephone exchanges, all electronic elements are selected and tested very carefully. Each single connection is calibrated for the worst possible situation (the so-called "worst case design"). In addition to these arrangements, reliable operation is also assured on other levels. In telephone exchanges there are always at least two computers. Each of them has the capability to carry the entire load of the exchange. Thus, if one of the computers fails, the other insures the continuation of the normal operations. The doubling of computers is performed in such manner that each computer is connected with all other centralized units, as well as with particular units, so that the failure of one computer could not involve a great number of the respective channels and connections. Assuming a good quality of manufacturing it is also easy to check all programs which constantly control the proper functioning of equipment in the telephone exchange. The operations of the central controlling unit move along according to the load-function sharing. Thanks to this principle it is possible to properly divide the actual work load and avoid losses. Namely, the computers receive their share of work both by function and by load. This means that some functions which cover the entire telephone exchange, are performed by one computer, while other functions are fully attended to by the other computer. The load is divided between the computers so that one of them takes over one group of channels, while

another has other groups of channels, etc. Of course, this principle ensures the reliable functioning of the entire telephone exchange operations. Even in case a computer fully fails, it is easy to execute the transfer of the load to other respective computer of computers, depending on how many additional computers are available in that telephone exchange.

### 3. The Construction of the System.

A system is easily divided into two basic units, as shown in picture 1 (represented as a block scheme). The heart of the telephone exchange is the central controlling unit, by which the exchange is being controlled. The central controlling unit consists of at least two computers together with memory units with a capacity which corresponds to that of the incoming-outgoing units. The program and data which exert the control over the telephone exchange are stored in the memory bank.

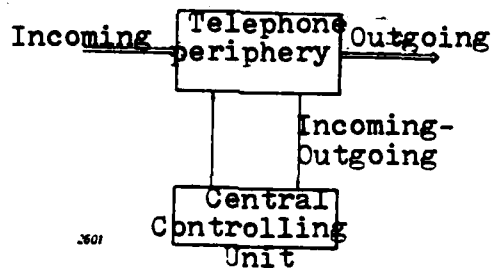

Picture 1. Block scheme of a telephone exchange.

By means of the incoming-outgoing alternate channel, the central controlling unit is connected to the telephone periphery. The periphery itself represents a system of circuits which makes possible the transfer of information in both directions. Thus, on the one hand, it supplies the telephone periphery with instructions, while on the other it brings those data, which are available to the telephone periphery, to the central controlling unit. Circuits are set up in such

a manner that they can perform transfer of information to sufficiently long distances yet protected from the external influences.

The term telephone periphery includes voice and signalling multiplexes, as well as the respective connecting and periphery circuits. The latter perform the switching of connections and gather various informations which arrive from other telephone exchanges.

### 3.1. Telephone Periphery.

The incoming traffic arrives to the incoming carriers (ITC). These carriers are connected to the receiving signalling multiplex (RSN), and also simultaneously to the incoming voice multiplex (IVN), as shown in picture 2. The connection to the receivers (REC), is established through the RSN. Receivers prepare information which is necessary for the establishment of the connection through the telephone exchange. This connection is established through the incoming multiplex (IVN), as well as through the outgoing voice multiplex (OVN) up to the outgoing carrier (OTC). The sending of signals to a distant telephone exchange is established from the OTC across the sending signalling multiplex (SSN) to the senders (SEND).

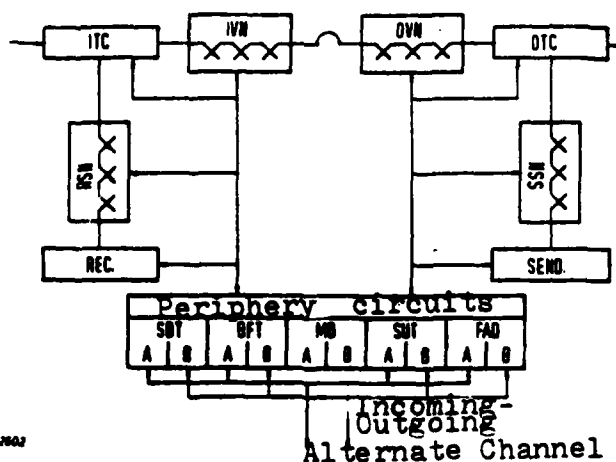

Picture 2. Telephone periphery.

The voice multiplex contains, consequently, two three-stage units. The IVN multiplex has the expanding and the mixed stage, the OVN multiplex has the mixed and the concentrating stages. Each stage-level consists of matrices of various sizes including their respective connections. Each connection has five reed (hermetically sealed) relays. Of these, four are used for the switching of the voice flows (quadruple), while the fifth relay is used to maintain the connection. The contact is supplied with a diode, which differentiates flow circuits, and a resistor, which serves as a stiffling element and which is connected across the coil with which the relays are actuated.

The voice multiplex is constructed so as to enable reaching all the outgoing points from any incoming point. It can be, optimally, adapted to traffic requirements. The voice multiplex is extended simply by adding new modules or matrices to places which had been marked in advance. The signalling multiplex is constructed similarly to the voice multiplex. The signalling multiplex is made in such a manner that it can have the direct access to receivers and senders, independently from the voice multiplex.

The peripheral circuits are instruments for the collection of information which is being prepared by the exchange carriers of the respective signalling units. The task of the peripheral circuits is also to intermediate the information flow in the direction of the telephone exchange's own central controlling unit. It serves, namely, both for signalling and for the control of the voice and signalling multiplexes. In picture 2, the individual units are shown. We collect data relating to the circuit situation by means of a SDT tester (situation data tester). The data are collected on the basis of an instruction issued by the SDT computer (SDT). Until a set time limit has expired, the information is at the disposition of the computer, which reads it easily.

One SDT tester can check 2048 carriers. The BFT tester functions similarly. By means of BFT we prepare a situation report concerning the "free-occupied" status of carriers, as well as connections with the voice and signalling multiplexes. The tester of signalling units (SUT) intermediates that information which the telephone exchange prepares through its signalling units; simultaneously, it checks the "free-occupied" situation of these units. The fast computer (FAD) applies quick control of certain carriers, specifically of the signalling units. The purpose of the marker control (MD) is to check on the relays for marking and connection establishment along the voice and signalling multiplexes. Units are divided in such way that one group is available for the incoming voice multiplex as well as for the incoming carrier of the respective receiver; in another group, units are set in such a manner that they are available for the outgoing voice multiplex and for the respective outgoing carrier. All units are doubled to prevent that the occurrence of a snag in one unit would cause failure. In this case the unit easily functions in advance along the doubled part and controlled by the second computer. The connection with the computer system has been executed along the incoming-outgoing alternate channel. The latter is calibrated in such manner that it concludes the respective transfer of information, and also informs on the appearance of any trouble.

### 3.2. The Central Controlling Unit.

The central controlling unit contains usually 2 to 6 central computers, and from 0 to 2 DMA data channels for direct access to the memory bank. The number of computers depends on the size of the telephone exchange, on the traffic, and on the kind of signallization. By experience, we calculate that one computer with direct memory access (DMA) to the data channel, processes approximately 220,000 connections per hour. On the basis of the reliability considerations,

it is required that there ought to be at least two computers. The block scheme of the processors with the DMA data channel is shown in the picture 3. The processor consists roughly of an arithmetical controlling unit, of memory and of incoming-outgoing unit. The connection between the computers and the telephone periphery is executed along the incoming-outgoing alternate channel.

The memory consists of separate blocks each of which has a capacity of 16 K ( 1 K = 1024 words). The maximal capacity of the memory is 512 K. Access to the memory is shown (schematically only) in picture 3. Other computers and the DMA data channels have, in this way, access to this memory. The system is made so that each processor has one part of the memory unit which is reserved for it, while the balance of the memory serving all processors. The access is regulated according to the priority principle. The incoming-outgoing devices serve for communicating with the system in terms of supervision and control of the system. By means of these devices it is easy to insert new data relating directions and carriers. Such devices serve for the diffusion of infor-

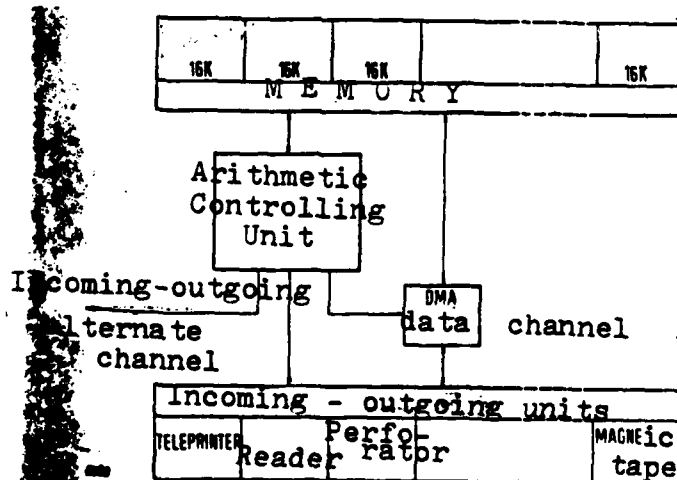

Picture 3. The central computer with DMA data channel for direct access to memory.

mation, alarms, the localization of failures, the registration of billing impulses, the measurement of traffic, etc. Inadvertent and chance snags may cause the outing of computers. In this case the computers have to be restituted into their normal operative status. Otherwise, it is easy - by means of other respective controlling units - to add the necessary or desired incoming-outgoing devices, such as, for instance, the teleprinter, the reading tape, the perforator, the units for magnetic tapes and discs, etc.

ITT 3200, a third generation computer, is extremely handy, and it is especially adapted for controlling units in electronic switching systems with stored programs. Words of 32 bits are used in it. The computer has more than one hundred instructions in its vocabulary. There can be found bits, syllables, abbreviations, half-words, words and double words. The computer has 2x16 registers which are accessible to the program. Since the computer has to operate in its real time, it is important that it executes the set operations within the given time spans available to it, since the operations cannot be delayed on account of shut-offs which are built-in into the computer. This system (ITT 3200) has 16 levels which are categorized according to their respective priorities.

We give here a few other features of the ITT 3200:

- The capacity of the memory can be extended from 8 K up to 512 K, all in blocks of 8 K and 16 K respectively.
- Memory cycle of 0.85 ms:
- Protection of memory from unforeseen and unauthorized insertions.
- Direct addressing of 128 K memory locations.
- Indirect addressing with pre- and post-indexing.
- Operational instructions.
- A system in which it is possible to leap ahead through the program in case of specific difficulties, etc.

#### 4. The Telephone Exchange Program Engineering.

We are now acquainted with the telephone periphery, namely with those units by means of which connections are being switched. By the way of such connections we receive and send signals and information necessary for the successful realization of a telephone call. All of these units are connected with the central controlling system, which is so constructed that it is able to issue correct instructions at the proper time. This is achieved by units within the central controlling system and by means of the program equipment in the telephone exchange. The programming software of the telephone exchange, which contains programs, can be visualized being of such kind which performs an instruction which was received and, then, issues the next instruction. The instructions make possible the execution of all telephone functions, which appear from the moment of initiating a telephone call through to the establishment of the connection up to its termination. The task of a program is similar to the task of a telephone operator with manual handling. The operator must, first, discover the new incoming call; he must find that the caller wants to have a connection. The programs have to perform the same task. An operator finds that somebody has requested a new connection by noticing the flashing of a small signal light. He sees that someone signals the request. In our system we must also discover the new incoming call, but this is done and acted upon not by an operator, but by a respective touch-actuated program. These programs appear and are executed periodically in set sequences by means of instructions which are generated and sent into the telephone periphery. The last touch changes the situation. If information regarding the state of the circuits is available in the memory, it is simple to ascertain whether any change in the circuits has taken place. We see now that the signal light, which was formerly used, has been substituted by an electronic

connection which shows, in its terminals, this information in binary form. A zero digit means that there is no signal in the circuit; conversely, digit 1 means that there is a change in the circuit. By comparing the preceding and the actual state, the program has concluded that there has taken place a change in the circuit. This, of course, activates other programs which have to ascertain the existence of the new call, which is the consequence of a specific new action performed by the calling customer. The relevant programs, now, do instruct the beginning and the execution of the verification procedure relating to data about the state of the connections, namely that a given change in the circuits indeed has resulted from a new action, and that it does belong to an already existing action. On the basis of all the data existing now, we decide what steps need to be undertaken. For instance, in the case of the MFC signallization we must connect the outgoing carrier to the receiver for MFC signallization. The realization of this action is assured by a programmed marker-driver (MD). In software we use various memory cells, which we call buffers and hoppers, in order to prepare the executions of an action. In our example, programs which discover a new call and request the establishment of a connection between the incoming carrier to the free, unoccupied, MFC receiver, are impressed in memory cells. Thus, so far as this call is concerned, the work of the program which has discovered the new call, is finished.

In addition, a program may be set in such way that we deposit a group of carriers simultaneously into the program, and then handle the whole group. In this case the entire group can be processed in an identical<sup>manner</sup> as the preceding group had been processed. This, of course, is true providing that a relevant change, which has triggered off the repeating of the whole sequence, has been established. Such a program can be repeated as many times as there are groups of carriers.

The entire operation flows according to the same program. The only difference is that we change in each flow the address of the group of carriers in question. Thus, really, during each subsequent new call, the same program which had been set into the respective MD buffer memory cells, is used.

The question is why do we promptly record the request for the marking of the connection into the MD buffer cell, when it would be simpler to recall the respective MD program and to mark the new discovered call, etc. The reason is found in the flow of telephone traffic in real computer time. We mention this to emphasize that we must not allow missing new calls because the occupied signal takes a certain time. If we do not discover such new calls, which have been made in that "occupied" time, then later we will not be able to do it at all and the calls are lost.

This is why the exchange's software is divided into different priority levels. Thus, typed programs discover that new calls exist, and that they have a higher priority than the programs which perform, for instance, the marking. This priority is realized in the central processing unit by means of a system of programmed interruptions. The elementary level belongs to the lowest priority. At this level programs which are not dependent on the clock, and which are easy to perform (sometimes only 10 ms later) are processed. The above mentioned typed programs have a higher priority than those programs at the elementary level, since they are at the clock level. The latter function at that level, which is actuated by the clock impulse, which in each 10 ms interrupts the processing at the elementary level. In such way we succeed in assuring that the priority functions are not delayed but are executed on time. We have mentioned elementary and clock levels. They are only two out of sixteen possible levels of programmed interruptions. The programmed inter-

ruption is performed as follows: at the moment of transferring the operation from one level to another, all data which are necessary for the continuation of operation at the interrupted level, are being deposited. In fact, the operation interruption at one level, can come only from the resident program of the higher level.

The operation at a given level is being defined by the so-called monitoring program. Thus, the monitoring program at the clock level determines which programs at the clock level will be processed at a certain time. In this way we prepare to regulate the convenience of activating the onset of specified fixed programs, providing that it is in accordance with the needs of the telephone traffic.

Since with each new call we use a determined quantity of information relating to that call, each call is allocated its own memory. The latter already contains the memory word within which it is easy to insert the information into the in advance foreseen places, as for instance:

- the address of the incoming carrier channel,
- the address of the outgoing carrier channel,
- the levels of the incoming, outgoing carriers, etc.,
- the numbers of the calling and called subscribers.

We have learned about some principles of the organization of software engineering in the Metaconta 10 C telephone exchange. We have demonstrated them in a few programs which are integral parts of the "call processing programs". These are the programs which take care of the proper service of telephone traffic. Yet, with all of these software engineering is not yet finished. The program scheme of telephone exchanges which have stored program control, enable us not only to process the telephone traffic, but also to supervise the telephone exchange, to communicate with the

supervising and maintenance personnel of the telephone exchange, to test the equipment which is being newly installed, and to test the units which failed, etc.

We have the other kinds of programs available in the telephone exchanges for such purposes, among them the following:

- programs to communicate with the telephone exchange (man - machine communications),
- on-line tests, programs,
- start up and recovery programs,
- traffic observation programs,
- automatic central processing unit (CPU tests programs),
- maintenance programs,
- installation test programs,
- telephone exchange extension test programs,
- programs executed when the processor is off line.
- utility programs, etc.

All of these programs are taking place in the telephone exchange in the manner which was described above. Some programs (such as, for instance, on-demand program), are not permanently deposited in the memory bank, but are, according to need, requested, namely imprinted into the memory by means of the incoming-outgoing units. These programs are developed according to the request and under conditions which are postulated.

#### 5. Conclusion.

The Metaconta 10 C is a modern electronic telephone system. It consists of units whose mutual functional interaction is simple and direct. This concept of its construction has contributed to the building of its high capability, to the maintenance simultaneous to operation, and to the great reliability of the exchange's operations.

Fast and reliable performance of the telephone operations is due to the third generation processors. The latter is able to possess instructions adapted to the requirements of the telephone traffic processing.

Author's name: Mag.Miha Unk,Dipl.Eng.  
Iskra - Electromehanika, Kranj.

DATE  
FILMED  
— 8