

AD-A095 643

NAVAL RESEARCH LAB WASHINGTON DC
COMPARATIVE TESTS BETWEEN TIESPAD AND SPA-66 RADAR DISPLAY. (U)
DEC 80 P M THIEBAUD
NRL-MR-4392

F/6 17/9

UNCLASSIFIED

NL

1 of 1
20/02/87

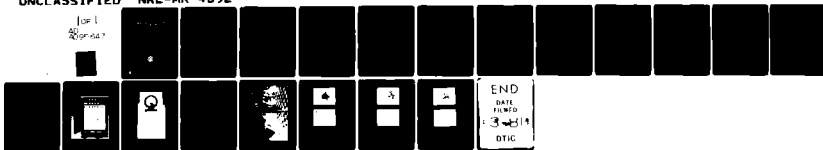

AD A 0930643

December 2, 1964

DBG FILE COPY

DTIC

REPORT DOCUMENTATION PAGE		READ INSTRUCTIONS BEFORE COMPLETING FORM
1. REPORT NUMBER NRL Memorandum Report 4392	2. GOVT ACCESSION NO. AD-A093643	3. RECIPIENT'S CATALOG NUMBER
4. TITLE (and Subtitle) <u>COMPARATIVE TESTS BETWEEN TIESPAD AND SPA-66 RADAR DISPLAY</u>		5. TYPE OF REPORT & PERIOD COVERED Final report on one phase of NRL Problem 53-0641-0-0.
		6. PERFORMING ORG. REPORT NUMBER
7. AUTHOR(s) P.M. Thiebaud		8. CONTRACT OR GRANT NUMBER(s)
9. PERFORMING ORGANIZATION NAME AND ADDRESS Naval Research Laboratory Washington, D.C. 20375		10. PROGRAM ELEMENT, PROJECT, TASK AREA & WORK UNIT NUMBERS 63516N; S0189AA9 53-0641-0-0
11. CONTROLLING OFFICE NAME AND ADDRESS Department of the Navy Naval Sea Systems Command Washington, D.C. 20362		12. REPORT DATE December 8, 1980
		13. NUMBER OF PAGES 19
14. MONITORING AGENCY NAME & ADDRESS (if different from Controlling Office) (14) NRL-MR-4392		15. SECURITY CLASS. (of this report) UNCLASSIFIED
		15a. DECLASSIFICATION/DOWNGRADING SCHEDULE
16. DISTRIBUTION STATEMENT (of this Report) Approved for public release; distribution unlimited.		
17. DISTRIBUTION STATEMENT (of the abstract entered in Block 20, if different from Report)		
18. SUPPLEMENTARY NOTES		
19. KEY WORDS (Continue on reverse side if necessary and identify by block number) Radar display Time compression Scan converter		
20. ABSTRACT (Continue on reverse side if necessary and identify by block number) Comparative tests between a time-compressed display (TIESPAD) and a conventional PPI (SPA-66) are described. TIESPAD is a 512 X 512 resolution scan converter with additional processing and memory to accomplish the time compression task using solid-state memory. The tests were made on the basis of a radar operator's ability to: (1) detect targets in random noise, (2) track a single target through heavy clutter, and (3) track multiple targets.		

CONTENTS

SUMMARY iv
INTRODUCTION 1
DESCRIPTION OF TIESPAD 1
DESCRIPTION OF TEST FACILITY 1
DESCRIPTION OF TESTS AND PRESENTATION OF RESULTS 2
DISCUSSION AND RECOMMENDATIONS 6
CONCLUSIONS 7
BIBLIOGRAPHY 9

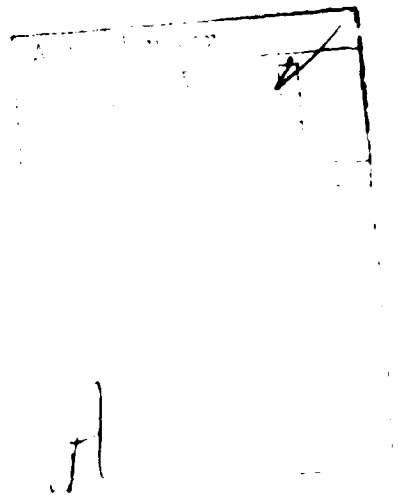

SUMMARY

Comparative tests were run between TIESPAD and the SPA-66, a product-line shipboard PPI display. The Time Encoded Spatial Display (TIESPAD) is a radar video processing unit designed and built by Naval Ocean Systems Center. (NOSC) It is a 512 x 512 resolution scan converter with additional processing and memory to accomplish the time compression task using solid-state memory; the output is displayed on a TV monitor. The tests were run using a combination of recorded live radar video and target simulator video. The tests were made to compare a radar operator's ability to detect targets in random noise, track a single target through heavy clutter, and track multiple targets. The following conclusions were reached:

- 1) Tracking in clutter is more efficient on TIESPAD than on SPA-66.
- 2) Detection efficiency is approximately equal on each.
- 3) Perceived signal-to-noise ratio is degraded on TIESPAD.
- 4) Higher resolution scan converter is desirable.
5. Operator controls need improvements.

COMPARATIVE TESTS BETWEEN TIESPAD AND SPA-66

RADAR DISPLAY

1. INTRODUCTION

The Time-Encoded Spatial Display (TIESPAD) is a radar video processing unit conceived, designed and built by the Naval Ocean Systems Center (NOSC). [1] The effectiveness of a time-compression display in enhancing detection and tracking of moving targets in a noisy or cluttered environment has been reported previously. [2,3] This memorandum will describe comparative tests between a TIESPAD unit furnished by NOSC and a conventional radar plan-position-indicator (PPI) (AN/SPA-66). The work was performed under the Radar Reliability/Performance Improvement (RR/PI) Program, sponsored by NAVSEA 62X.

2. DESCRIPTION OF TIESPAD

The function of the Time-Encoded Spatial Display (TIESPAD) unit (Fig. 1) is to record and display radar target history and to generate a time-compressed display for enhancing target detection and tracking. This is accomplished by the use of a solid-state scan converter with expanded memory and processing functions for recording the time of last hit and the duration of the events at each display cell. The design adopted contains a matrix of 512 x 512 display cells. The TIESPAD memory accommodates video, frame tag, and history bits for each cell. The video word (4 bits) represents the greatest value of video during the last sixteen scans or frames, the frame word (4 bits) provides the time referenced for the last time of entry, and the history word (4 bits) records the number of consecutive scans in which an event occurred. In decoding these bits, the start time for the event is taken as frame minus history (F-H) and the end time is frame (F). The decode circuit simply unblanks the video in each display cell when the read frame count falls between these time limits.

The display unit used in these tests (Fig. 2) is a commercial, fourteen inch, 512 line, TV monitor, mounted in a sloping front rack. It was masked with a circular ten inch cutout on which was mounted a reflection plotter from a SPA-66 display. The height and slope of the TV display were matched as closely as possible to that of the actual SPA-66 display.

3. DESCRIPTION OF TEST FACILITY

These tests were conducted at the Chesapeake Bay Detachment (CBD), the Naval Research Laboratory facility near Chesapeake Beach, MD. The display test bed at CBD is equipped to generate real or simulated radar targets, to record these signals, and to play them back and display them in a controlled environment. Figure 3 is a block diagram of the equipment contained in the

test bed. The display test bed, excluding the actual radar equipment, is housed in a room which is divided into three portions (Fig. 4). Two portions of the room are screened off to allow complete or partial darkening. These two portions house the TIESPAD display and the SPA-66 display.

The signal generation and recording equipment are housed in a third portion of the room. This includes a T-3 target simulator and the tape recording equipment. The T-3 target simulator is a unit used by the Fleet to train radar operators. It is capable of generating the following signals: (1) up to six simultaneous maneuvering targets, which can be calibrated in amplitude as a function of range, (2) simulated receiver noise which can be set and calibrated in amplitude, (3) simulated sea return, (4) simulated jamming strobes, (5) facilities to accept signals from an external source and combine them with the internally generated signals. The recording equipment consists of two commercial rotating head TV recorders. The radar signals are conditioned by external circuits both on the input and output sides to make them compatible with the recorders. It is possible to play a tape back on one recorder, supplement the signals with the signals from the T-3 simulator, and re-record it on the second recorder. It thus becomes possible to have more than the basic six target signals which the T-3 simulator is capable of generating on a given test tape.

4. DESCRIPTION OF TESTS AND PRESENTATION OF RESULTS

The tests consisted of three types of comparative tests between the TIESPAD and the SPA-66: The first test compared the signal-to-noise ratio (S/N) for initial detection, the second test compared the effectiveness of tracking in a very heavy clutter background, the third test compared the effectiveness of tracking with many targets on the screen at the same time. The tests were divided into runs of approximately ten minutes duration, to minimize fatigue as a factor.

To calibrate the T-3 target generator, a tape was made in which one target was varied in range in ten mile increments from 10 to 130 miles. This tape was then played back and the playback amplitudes were recorded for each range, giving a range profile for the target amplitudes. These amplitudes were plotted on a logarithmic (dB) scale, referenced to the maximum range, as a function of range.

A series of ten minute tapes were made, with targets starting at spaced intervals in time, and appearing at approximately 130 miles in range, running with decreasing range. A time exposure photograph of one such run for the entire ten minutes is shown in Fig. 5. At 130 miles, the target was well below noise. A total of six such tapes were made, two with five targets, two with three targets, and an additional two with five targets.

In running the tests, the test operator started with the TIESPAD display for one ten minute run. After a short rest, he used the SPA-66 for a similar ten minute run. On both the TIESPAD display and the SPA-66, the test operator indicated with a grease pencil the point at which initial detection was made. He then plotted sufficient points of the track to be sure that it was a valid track.

The test observers measured the range for initial detection for each target and marked it on the reflection plotter near the point of initial detection. An identifying label was printed on the reflection plotter and it was photographed. An example of one of these photographs is seen in Fig. 6. Three runs on each of the displays were made by seven operators with a total of thirteen targets on each display. This gives a total of 91 detections on each display. The range from each of these detections was converted to a signal level through the use of the range profile plot. The signal level for initial detections was averaged for each operator for each display. In addition, an overall average for each display was calculated. Differences were taken showing the relative performance of each operator on the displays and the overall efficiency of the displays. The results of these calculations are shown in Table 1.

Operator	MS	SJW	JLW	LG	EP	AM
	-1.82 dB	0.83 dB	-1.56 dB	0.33 dB	-1.00 dB	-2.4 dB

TABLE 1 - Detection Efficiency of TIESPAD Relative to SPA-66

Table 1 shows the relative detection efficiency of the operators on the two displays. Negative numbers indicate a higher average signal level was required for the TIESPAD display. It will be noted that the detection efficiency of the two displays was very close, the greatest difference was for operator AM, being 2.4 dB greater signal level required for detection on the TIESPAD display. The overall average was 0.66 dB higher signal required for detection on the TIESPAD display. These differences do not appear to be significant. The number of operators is too small, and the precision of calibration is not sufficient to warrant any conclusion other than that the displays are approximately equal in detection efficiency.

The operators' motivation was very high and the run times were quite short, so that fatigue was not a factor. Comments were made by several operators to the effect that higher levels of concentration were required on the SPA-66 display for efficient detection. Two subjective conclusions may be drawn: (1) The signal-to-noise ratio observed on the TIESPAD unit at any given time was lower than that observed on the SPA-66 for a given signal level, possibly due to collapsing loss* from the non-coherent scan-scan integration of noise which occurs on the TIESPAD display; (2) the noise advantage for the SPA-66 appears to be overcome by the time compression effect which enhances a moving target on the TIESPAD display.

The second test series compared the efficiency of the TIESPAD unit with that of the SPA-66 in tracking a target in a high clutter background. The

* There are other forms of scan-history display which have no collapsing loss, such as ITCD (Interleaved Trace Correlating Display).

test consisted of tracking a single target in a high clutter background. Six ten minute test tapes were made for this series. An SPS-10 radar, illuminating the area in the immediate vicinity of the CBD site was used to provide the clutter background. The sensitivity of the radar was reduced slightly to minimize the number of naturally occurring, moving targets. The signals from the SPS-10 were combined with one simulated target from the T-3 trainer. The simulated target was maneuvered with respect to the clutter to make tracking difficult for the operator. A ten-minute time exposure of one such run is shown in Fig. 7. The dotted line going through the clutter is the track of the target as seen on successive radar sweeps. The range displayed is 32 miles.

In running the clutter tests, the operator sitting at the console (either SPA-66 or TIESPAD) was told at what azimuth the target would appear near the edge of the screen. (In the illustrated example, this was at approximately the southeast edge of the screen.) In all cases the operator had at least several sweeps with the target in a clear environment, i.e., not in clutter. He marked the successive positions of the target to the best of his ability on the reflection plotter. If, in the operator's and test observer's opinion, the target was hopelessly lost, he was shown the then current position of the target and allowed to continue tracking. This condition was indicated on the reflection plotter by printing "LOST" next to the appropriate position and printing the word "COACHED" next to the position where the current position was indicated to the operator. If he had lost the target and was able to re-acquire it without help this was indicated on the reflection plotter by printing the letters "ACQ" next to the position where he re-acquired the target. In some cases it was impossible to track through patches of saturated clutter. This was also marked on the reflection plotter. Data photographs of each tracking run were made; an example of one such run is shown in Fig. 8.

A total of three tracking runs on each display were made by each operator, making a total of 21 tracking runs on each display or 42 total tracking runs. The 42 data photographs of the tracking runs were submitted to each of six judges for a determination of tracking quality on a scale of one to five. The criteria for this track quality is shown in the following table.

Numerical Rating	Description	Criteria
1	Very Poor	Almost no tracking
2	Poor	Some tracking, requires coaching when lost
3	Fair	More tracking, may require occasional coaching when lost
4	Good	Good tracking, is able to re-acquire when lost
5	Excellent	Almost perfect tracking

TABLE 2 - Track Quality Criteria

Each grade for each run for each operator on each display was then averaged. The results of these computations are shown in Table 3.

Operator	MS	SJW	DRJ	JLW	LG	EP	AM
TIESPAD	4.22	3.83	4.05	4.44	4.17	4.22	3.61
SPA-66	3.22	2.05	2.67	2.83	2.78	2.94	2.72

TABLE 3 - Track Quality Results

The effectiveness of the TIESPAD vs. the SPA-66 in the tracking function for each operator is given a numerical value in this table. The difference in tracking capability for the operator using the TIESPAD, contrasted with those using the SPA-66, is apparent. Despite the variability from operator to operator using a given display, the improvement of each operator using TIESPAD is consistent. All 21 runs from each display were averaged and again the improvement is consistent with the improvement shown by the individual operators. Table 4 shows a tabulation of the same results in the descriptive terms used in the Track-Quality-Criteria table.

Operator	MS	SJW	DRJ	JLW	LG	EP	AM
TIESPAD	Good	Good	Good	Good	Good	Good	Good
SPA-66	Fair	Poor	Fair	Fair	Fair	Fair	Fair

TABLE 4 - Track Quality Results

The results are consistent: the overall track quality improved from a low "fair" to a solid "good", when using TIESPAD. Comments were made by several operators to the effect that, when tracking with the SPA-66, if one's attention were diverted even momentarily the track was lost and there was little hope of re-acquiring the target. It was appreciably easier to re-acquire the target on the TIESPAD after diversion. The apparent motion of the target on the TIESPAD display spanned the gap in the track which was missed during the diversion. Another way of saying the same thing is that much higher levels of concentration were required on the SPA-66 to perform the task of tracking a target through clutter. There seemed to be some negative correlation between the tracking ability of the operator while tracking on a conventional display and the amount of improvement which showed when using the TIESPAD; however, the data taken was not sufficient to warrant any firm conclusions on this aspect of the subject.

The third test compared the ability of an operator to track many targets at the same time, using either the SPA-66 or the TIESPAD display. Three test tapes were made for each display unit. One was with five targets appearing on the screen, a second with ten targets appearing on the screen, and the third with fifteen targets appearing on the screen. Figure 9 shows a ten minute time exposure of a fifteen target tape run.

The operators were asked to detect and track as many targets as they could during the course of a ten-minute run. They sat at one of the consoles and a five-target, ten-minute run was used. They rested briefly, and then a second ten-minute run of a ten-target tape was used. They rested briefly again and then ran the third test tape with fifteen targets on the same display. This completed one series. Completely different tapes were used when the next series was run on the other display. A photograph of the reflection plotter from one fifteen target run is shown in Fig. 10.

The data photographs taken of the reflection plotters for all runs by each of seven operators on both displays showed very little difference in quality between the SPA-66 and the TIESPAD. However, operators did comment that less concentration was required when tracking on the TIESPAD display. A surprising result of this test was the ability of all of the operators to show tracks of as many as fifteen targets simultaneously. They did not mark the plotter for each sweep of the display, but skipped sweeps and only updated tracks occasionally. In at least some cases, the average time required for an operator to put a mark on the reflection plotter was appreciably shorter for the TIESPAD than with the SPA-66. This appeared to be due to the fact that the targets were always present on the TIESPAD and the operator had to wait for the sweep to appear on the SPA-66. Tracking of this many targets required extremely high levels of concentration.

5. DISCUSSION AND RECOMMENDATIONS

The TIESPAD is very effective in presenting a time compressed history of the events occurring in the displayed area. The elimination of redundant information through the use of an expanded scan-converter makes the unit much more attractive than massive bulk memory or the use of mechanical moving devices (tape recorder and disc memory). There are, however, a few areas of improvement which could be made. They can be divided roughly into two categories, performance and controls.

The integration of sixteen scans of history and the presentation of these in a time compressed manner is perceived on the screen as an increased noise level. This effect seems to occur with receiver noise, jammer noise, non-random noise such as sea return, and land clutter. Land clutter appears more dense on the TIESPAD display than on a conventional display. These effects occur only in the TIESPAD mode; when the unit is used as a scan-converter only, there is no perceived increase in the noise level. Pre-storage video processing should markedly improve the noise performance. Two types might conceivably be used. They are: (1) constant false alarm rate (CFAR) processing, with large cell averaging and (2) sweep-to-sweep integration over the beam width of the radar used.

The second area of potential performance improvement is in the resolution of the overall system. The use of a 512 x 512 cell matrix in the scan converter, and the use of 525 line TV monitors limits the resolution of the diagonal (45 degree) range sweeps to something less than ninety resolvable dark and light elements. In the presentation of narrow-angle targets, only one or two dots were present on the TV display whereas a complete arc was present on the SPA-66. The use of a 1000 x 1000 cell matrix would give resolution approximately equal to that available in the current displays. The use of such a matrix would obviously result in four times the memory size in the scan-converter. The decrease of solid state memory prices in the near future may make this approach economically feasible.

The control knobs and switches on the TIESPAD were at times difficult to use. The unit was built for experimental use in a laboratory environment, so compromise on controls was necessary. The controls should be available to an operator seated at a display console. The following changes would probably result in a more operationally useful display:

- (a) single button erase for the entire memory (when changing range scales on the display, it sometimes took two or three sweeps to clear the screen);.
- (b) mode switching available on buttons (when switching from one mode to another, transients were sometimes introduced into the display which might not disappear for lengthy periods);
- (c) decimal increments between range rings instead of binary increments;
- (d) dedication of a one-bit memory plane to range rings and graphics (the presence of range rings written into the video was, at times, distracting and they could not be easily removed when operating in the TIESPAD mode);
- (e) smooth decrementing of the variable persistence;
- (f) the use of a track ball, light pen, or stiff stick control to move the cursor.

6. CONCLUSIONS

a. TIESPAD performs the time compression and display function dependably and well, without the need for the massive bulk memory which was necessary in previous electronic time compression systems [3].

b. Tracking in heavy clutter is greatly improved by using TIESPAD over a conventional PPI (SPA-66).

c. Detection in moderate, random noise, is approximately equal between TIESPAD and SPA-66.

d. Perceived (on screen) signal-to-noise ratio (S/N) is seriously degraded in noise or jamming in the TIESPAD mode*, but not in normal scan converter mode.

e. A higher resolution scan converter and display system are highly desirable.

f. TIESPAD operator controls need improvement in several areas.

* ITCD may be better (Ref. 4).

BIBLIOGRAPHY

1. B. Directo, R. Morin, "Time-Encoded Spatial Display," NOSC TD 258, 25 Apr 79.
2. "Preliminary Design for a Modularized Image Processor with Optional Time Compressed Display Capability," NELC TN 3173, 11 Jun 76.
3. G. Linde, W. Waters, "Scan-to-Scan Integration by Means of an Interleaved Trace Correlating Display (ITCD)," NRL Report 8319, 13 Aug 79.

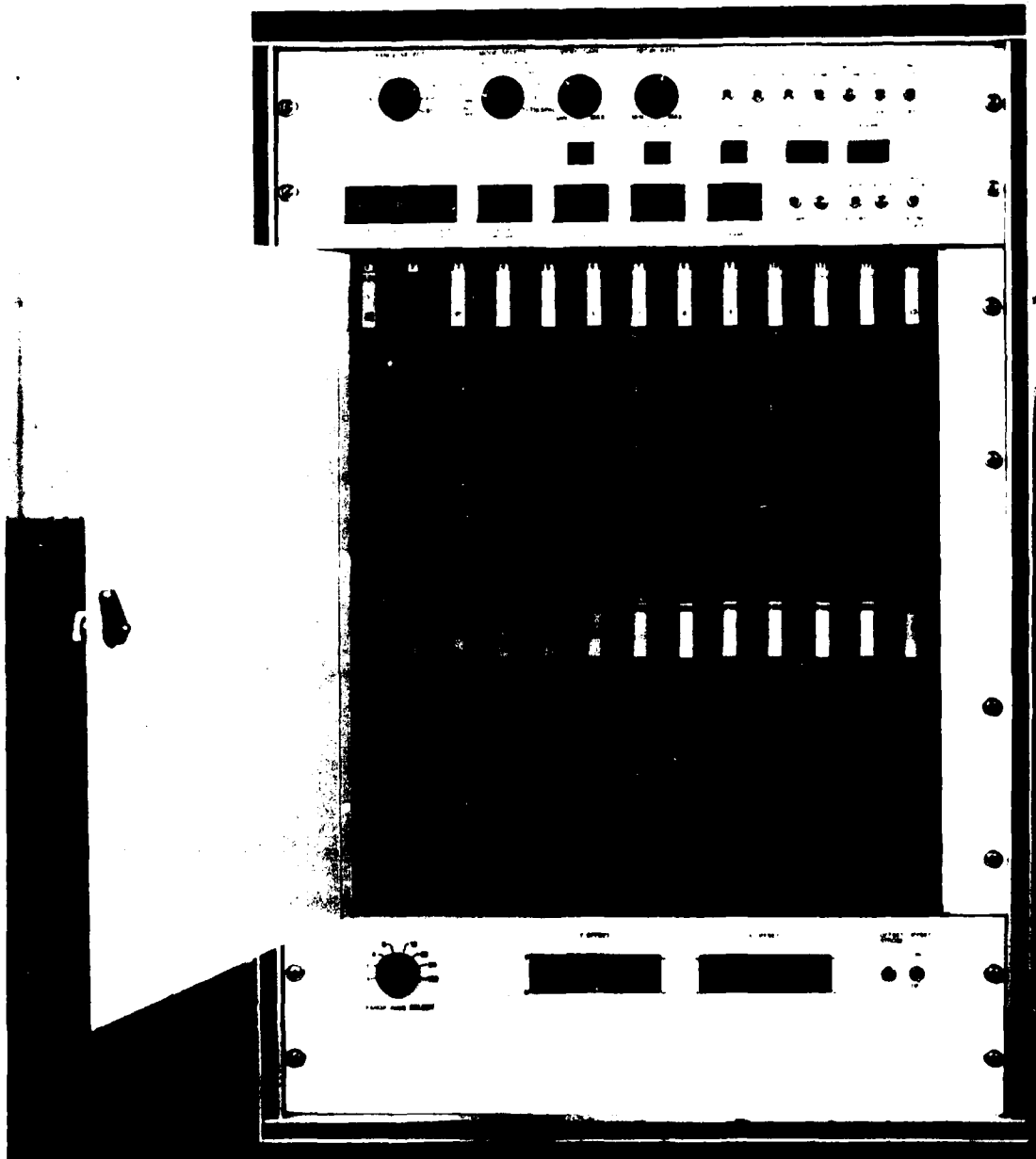

Fig. 1 — TIESPAD radar video processing and scan converter unit

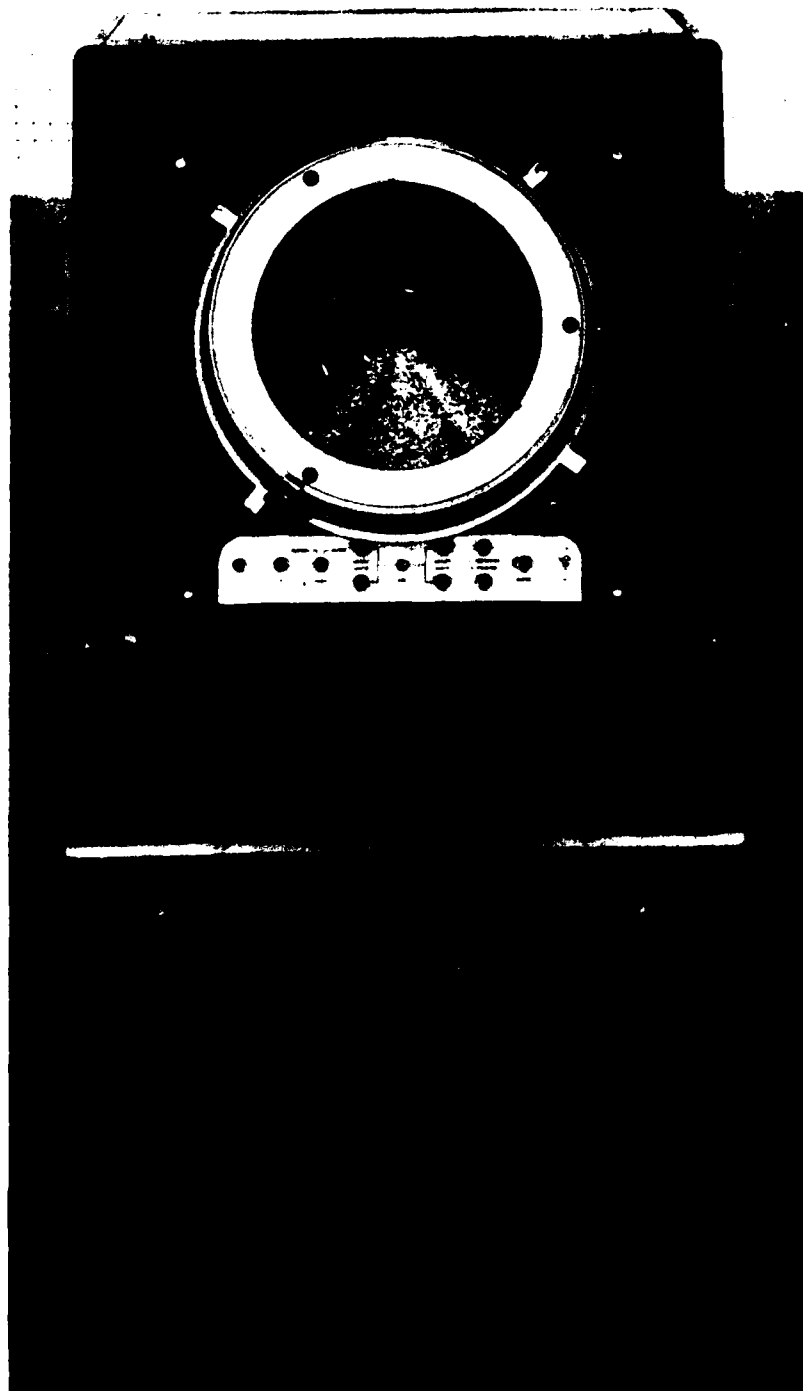

Fig. 2 - TIESPAD display unit

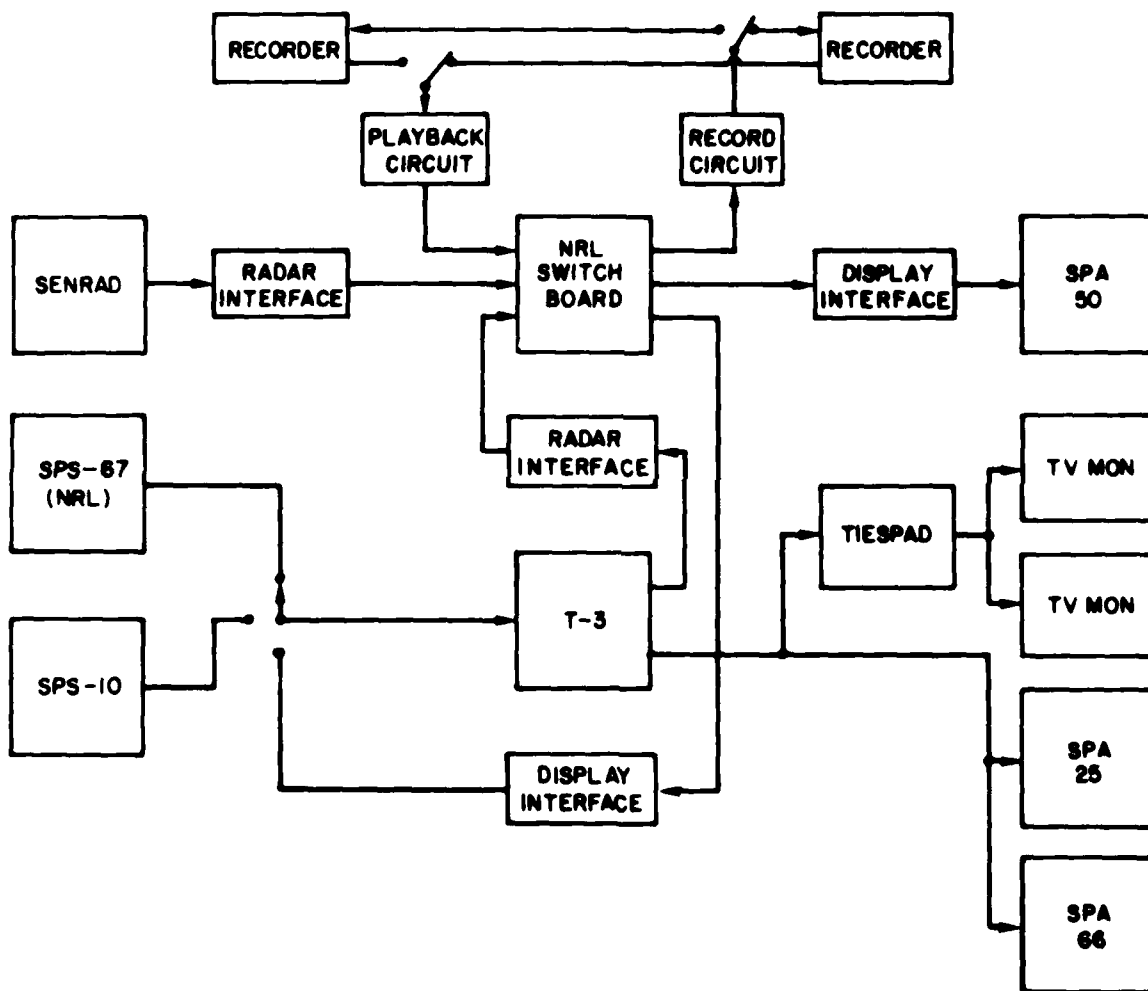

Fig. 3 - NRL display test bed block diagram

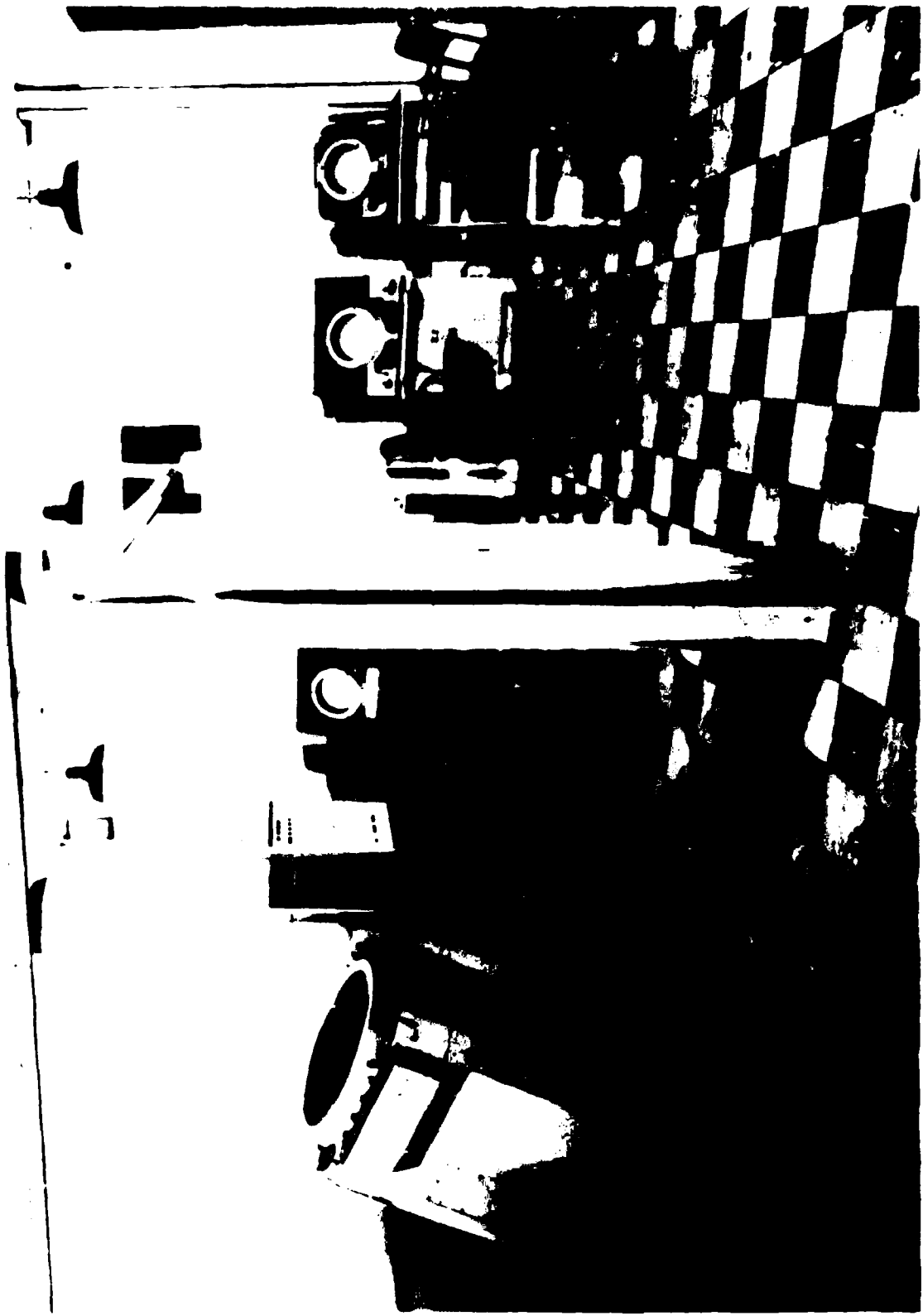

Fig. 1. NPL Laboratory.

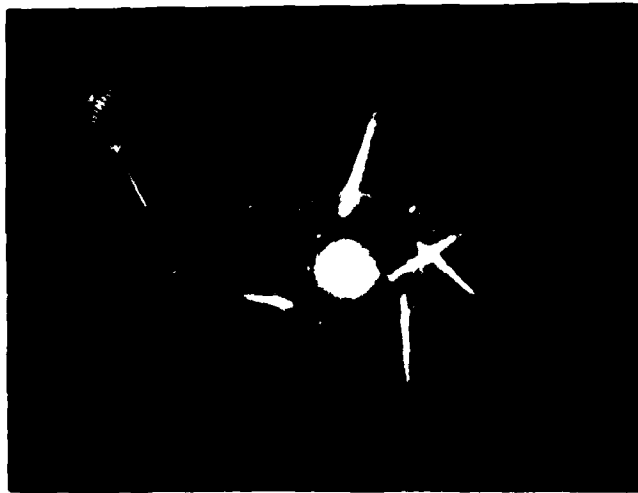

Fig. 5 - Ten minute time exposure of detection run



Fig. 6 Reflection plotter used for detection run (Fig. 5)



Fig. 7 -- Ten-minute time exposure of tracking run



Fig. 8 -- Reflection plotter used for tracking run (Fig. 7)

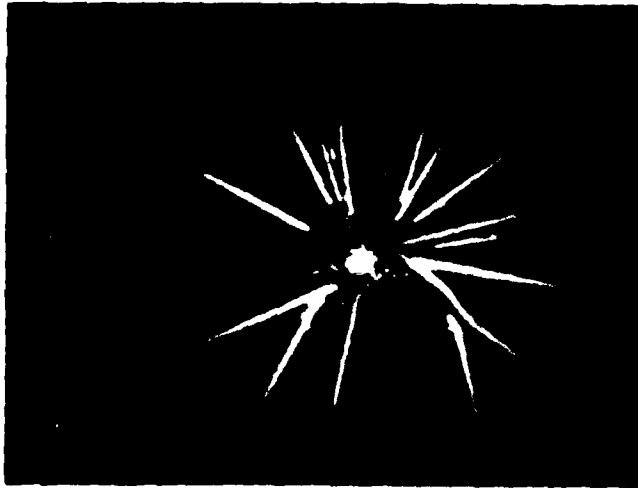

Fig. 9 — Ten-minute time exposure of multiple target run (15 targets)

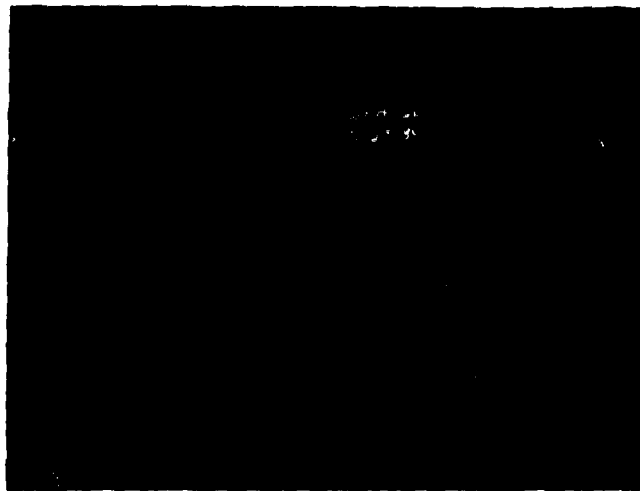

Fig. 10 — Reflection plotter used for multiple target run (Fig. 9)

