

AD-A095 736

NAVAL POSTGRADUATE SCHOOL MONTEREY CA F/G 19/4
A-10/GAU-8 LOW ANGLE FIRINGS VERSUS SIMULATED SOVIET TANK BATTAL--ETC(U)
AUG 80 R H STOLFI, R R MCEACHIN

UNCLASSIFIED

NL

for 2
pages

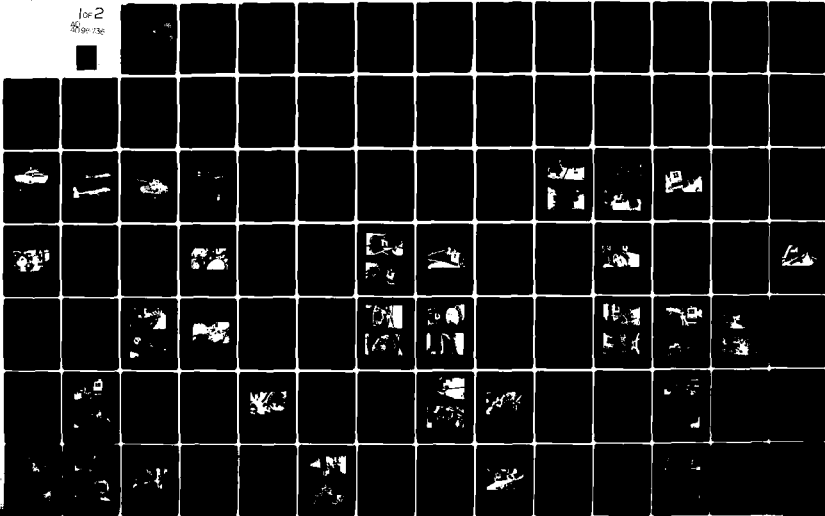

①

AD A 095736

NAVAL POSTGRADUATE SCHOOL

Monterey, California



LEVEL II

DTIC ELECTE
S D
MAR 0 2 1981
E

A-10/GAU-8 LOW ANGLE FIRINGS VERSUS
SIMULATED SOVIET TANK BATTALION
(HONEYWELL LOT NUMBER 0L78D043-016)
(ARRAY 3)
2 FEBRUARY 1979.
R.H.S. STOLFI
R.R. MCEACHIN
AUGUST 1980

Approved for public release; distribution unlimited.

Prepared for: A-10 System Program Office
Wright Patterson Air Force Base
Ohio 45433

81 3 2 023

NAVAL POSTGRADUATE SCHOOL
Monterey, California

Rear Admiral John J. Ekelund
Superintendent

David A. Schradly
Acting Provost

The work reported herein was supported by the A-10 System Program Office, Wright-Patterson Air Force Base, Ohio. The reproduction of all or part of this report is authorized.



Russel H.S. Stolff
Associate Professor of History

Reviewed by:

Released by:



Sherman W. Blandin
Acting Chairman
Department of National
Security Affairs

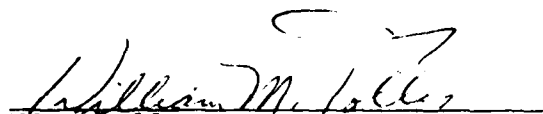

W.M. Tolles
Dean of Research

Unclassified

SECURITY CLASSIFICATION OF THIS PAGE (When Data Entered)

REPORT DOCUMENTATION PAGE		READ INSTRUCTIONS BEFORE COMPLETING FORM
1. REPORT NUMBER NPS-56-81-001	2. GOVT ACCESSION NO. AD-A095736	3. RECIPIENT'S CATALOG NUMBER
4. TITLE (and Subtitle) A-10/GAU-8 Low Angle Firings Against Simulated Soviet Tank Company (Array 3) (LAVP Lot # OL78D043-016, Honeywell)		5. TYPE OF REPORT & PERIOD COVERED Special Report on Tank Array Firings of 2 Feb 1979
		6. PERFORMING ORG. REPORT NUMBER
7. AUTHOR(s) R.H.S. Stolfi R.R. McEachin		8. CONTRACT OR GRANT NUMBER(s)
9. PERFORMING ORGANIZATION NAME AND ADDRESS Naval Postgraduate School Monterey, California 93940		10. PROGRAM ELEMENT, PROJECT, TASK AREA & WORK UNIT NUMBERS
11. CONTROLLING OFFICE NAME AND ADDRESS A-10 System Program Office Wright-Patterson Air Force Base Ohio 45433		12. REPORT DATE August 1980
		13. NUMBER OF PAGES 134
14. MONITORING AGENCY NAME & ADDRESS (if different from Controlling Office)		15. SECURITY CLASS. (of this report) Unclassified
		15a. DECLASSIFICATION/DOWNGRADING SCHEDULE
16. DISTRIBUTION STATEMENT (of this Report)		
17. DISTRIBUTION STATEMENT (of the abstract entered in Block 20, if different from Report)		
18. SUPPLEMENTARY NOTES		
19. KEY WORDS (Continue on reverse side if necessary and identify by block number) 1. Automatic cannon ammunition 6. Combat stowed targets 2. GAU-8 cannon 7. Gun ammunition lethality 3. A-10 aircraft 8. MBT vulnerability & survivability 4. Main Battle Tank (MBT) 9. Lot Acceptance Verification Program (LAVP) 5. Empirical firing tests		
20. ABSTRACT (Continue on reverse side if necessary and identify by block number) This report describes LAVP firings of the 30mm GAU-8 ammunition manufactured by Honeywell. The firings were conducted on 2 February 1979 utilizing the A-10/GAU-8 weapon system and ammunition from LAVP Lot Number OL78D-43-016. Targets for the firings were 31 US M-47 tanks arranged in a static formation to simulate a Soviet MBT Battalion of three ten (10) tank companies and a battalion commander tank. Also included in the target array were four plywood mock-ups, simulating the tank battalion's ZSU-23/4		

DD FORM 1 JAN 73 1473

EDITION OF 1 NOV 68 IS OBSOLETE
S N 0102-014-6601

Unclassified

SECURITY CLASSIFICATION OF THIS PAGE (When Data Entered)

Unclassified

SECURITY CLASSIFICATION OF THIS PAGE(When Data Entered)

(Block 20 continued)

anti-aircraft defense. Five A-10 pilots conducted firing passes at the formation of M-47 target tanks and ZSU-23/4 mock-ups. Normal A-10 operational tactics for low altitude, low dive angle attacks were followed. This publication contains a description of the firing conditions, A-10 attack parameters, weapons effects derived from the firings, and individual damage assessments for each target tank in the array. The data collected from this test verify the acceptability of the ammunition lot tested, and the effectiveness of the A-10/GAU-8 weapon system as one capable of inflicting catastrophic (K), mobility (M), and firepower (F) kills against modern main battle tanks.

Accession For	
NTIS GRA&I	<input checked="" type="checkbox"/>
DTIC TAB	<input type="checkbox"/>
Unannounced	<input type="checkbox"/>
Justification	
By _____	
Distribution/	
Availability Codes	
Dist	Avail and/or Special
A	

TABLE OF CONTENTS

	Page
Executive Summary	1
Attack Parameters	1
Weapon Effects	2
Results	2
Test Conditions	3
Background	3
Test Philosophy	6
Simulated Ground Combat Situation	6
Target Tanks	8
Test Results	8
Damage Assessment	16
Tank Number 2	17
Tank Number 4	22
Tank Number 7	25
Tank Number 17	28
Tank Number 19	32
Tank Number 20	35
Tank Number 21	38
Tank Number 22	42
Tank Number 23	46
Tank Number 26	51
Tank Number 27	54
Tank Number 28	57
Tank Number 29	61
Tank Number 30	64
Tank Number 31	69
Tank Number 32	72
Tank Number 33	75
Tank Number 34	79
Tank Number 35	82
Tank Number 36	86
Tank Number 37	90
Tank Number 38	94
Tank Number 39	97

TABLE OF CONTENTS (Concluded)

	Page
Tank Number 40	100
Tank Number 41	109
Tank Number 42	112
Tank Number 43	115
Tank Number 44	120
Tank Number 45	123
Summary and Conclusions	127
Appendix A, Graphic and Summary Data.	129
Appendix B, Definitions	133

LIST OF FIGURES

Figure	Page
1. Russian T62 Medium Tank	10
2. U.S.A.F./Fairchild Republic A-10 Close Air Support Aircraft	11
3. United States M-47 Combat Tank	12
4. Mock-Up Target of Soviet ZSU-23/4 AAA Unit	13
5. Crossection of a 30mm Armor Piercing Incendiary (API) Projectile	14
6. Mission A-3, Target Layout of Simulated Soviet Tank Battalion	15
7. Impact Diagram, Target 2	18
8. Impact Six, Target 2, Perforation of Rear Bottom Hull Armor into Transmission Compartment	19
9. Impact Seven, Target 2, Perforation of Rear Hull Armor and Penetration into Transmission Case	19
10. Impact Eight, Target 2, Perforation of Rear Hull Armor and Penetration into Transmission Case	20
11. Impact Nine, Target 2, Perforation of Rear Hull Armor and Penetration into Transmission Case	20
12. Impact Eleven, Target 2, Perforation of Rear Hull Armor (Transmission Oil Cooler Line was Penetrated Causing Oil Leak)	21
13. Impact Diagram, Target 4	23
14. Impact Five, Target 4, Showing Destroyed Adjusting Idler Hub in the Left Track	24
15. Impact Diagram, Target 7	26
16. Impact Nine, Target 7, Showing Destroyed End Connector, Damaged Track Shoe Pins, and Broken Right Drive Sprocket	27

LIST OF FIGURES (Continued)

Figure	Page
17. Impact Diagram, Target 17	29
18. Impact Five, Target 17, Perforation of Right Side of Turret	30
19. Impact Six, Target 17, Perforation of Right Side of Turret	30
20. Impact Seven, Target 17, Perforation of Right Side of Turret	31
21. Impact Diagram, Target 19	33
22. Impact Eight, Target 19, Perforation of Center Access Door into Transmission Compartment, and Penetration into the Transmission Case	34
23. Impact Diagram, Target 20	36
24. Impact Nine, Target 20, Perforation of the Hull Armor and Penetration into the Right Fuel Tank	37
25. Impact Diagram, Target 21	39
26. Impact Six, Target 21, Perforation into Fighting Compartment Through Vision Block in Commander's Cupola	40
27. Impact Nine, Target 21, Showing Destroyed Periscope Head at Commander's Station	40
28. Impact Seven, Target 21, Showing Location of Strike Which Jammed the Turret	41
29. Impact Diagram, Target 22	43
30. Impact Ten, Target 22, Which Damaged the Right Number 5 Roadwheel, Destroyed the Right Number 4 Roadwheel Bearing Spacer, and Damaged the Spindle	44
31. Impact Twelve, Target 22, Which Destroyed the Right Number 4 Roadwheel Hub and Outer Bearing	44

LIST OF FIGURES (Continued)

Figure	Page
32. Impact Six, Target 22, Showing Damage to Right Drive Sprocket	45
33. Impact Twenty-Five, Target 22, Showing Damage to Right Drive Sprocket	45
34. Impact Diagram, Target 23	47
35. Impact Sixteen, Target 23, Perforation of Rear Hull Armor into the Transmission Compartment, Which Penetrated the Transmission Thermostat and Cross-Over Line	48
36. Impact Eighteen, Target 23, Perforation of Rear Hull Armor and Penetration into the Transmission Case	48
37. Impact Twenty-One, Target 23, Perforation of Rear Hull Armor and Penetration into the Transmission Case	49
38. Impact Ten, Target 23, Penetration into the Left Final Drive	49
39. Impact Eleven, Target 23, Penetration into the Left Final Drive	50
40. Impact Twenty-Five, Target 23, Penetration into the Right Final Drive	50
41. Impact Diagram, Target 26	52
42. Impact Twelve, Target 26, Perforation of Rear Hull Armor and Penetration into the Transmission Case .	53
43. Impact Thirteen, Target 26, Perforation of Rear Hull Armor and Penetration into the Transmission Case	53
44. Impact Diagram, Target 27	55
45. Impact Six, Target 27, Showing Damage to Left Number 2 Track Support Roller	56

LIST OF FIGURES (Continued)

Figure	Page
46. Impact Diagram, Target 28	58
47. Impact Thirty-Eight, Target 28, Perforation of Hull Armor and Penetration into Left Fuel Tank	59
48. Impact Thirty-Four, Target 28, Which Destroyed the Left Number 5 Roadwheel Hub	59
49. Impact Forty-Four, Target 28, Which Destroyed the Left Number Six Roadwheel Hub	60
50. Impact Diagram, Target 29	62
51. Impact Thirty-Four, Target 29, Perforation of Left Hull Armor Which Severed the Steering Control Rod	63
52. Impact Thirty-Six, Target 29, Perforation of Rear Hull Armor and Penetration into the Transmission Case	63
53. Impact Diagram, Target 30	65
54. Impact Thirty, Target 30, Perforation of Bottom Hull Armor and Penetration into Left Fuel Tank (Initial Impact was on Left Track Tension Idler Wheel and Left Number 6 Roadwheel)	66
55. Impact Thirty-Four, Target 30, Perforation of Left Hull into Transmission Compartment	66
56. Impact Thirty-Four, Target 30, Caused Penetration of Transmission Oil Cooler Line Behind Armor	67
57. Impact Thirty-Six, Target 30, Penetration of Left Hull Armor and Penetration into the Transmission Case	67
58. Impact Forty-Seven, Target 30, Penetration into the Right Final Drive	68
59. Impact Diagram, Target 31	70

LIST OF FIGURES (Continued)

Figure	Page
60. Impact Twenty-One, Target 31, Perforation of Hull and Penetration into Left Fuel Tank	71
61. Impacts Thirty and Thirty-Three, Target 31. Impact 30 Perforated the Hull Armor and Penetrated the Left Fuel Tank. Impact 33 Perforated the Hull Armor into the Engine Compartment	71
62. Impact Diagram, Target 32	73
63. Impact Seventeen, Target 32, Perforation of the Hull Armor and Penetration into the Left Fuel Tank	74
64. Impact Diagram, Target 33	76
65. Impact Twenty-Six, Target 33, Perforation of Brake Adjust Access Door into Transmission Compartment .	77
66. Impact Twenty-Six, Target 33, Penetration of Transmission Case (Brake Adjust Access Door Removed . .	77
67. Commander Manikin, Target 33, Showing Damage from Impacts 6 and/or 8, Which Perforated the Left Side of the Turret	78
68. Gunner Manikin, Target 33, Showing Damage from Impacts 6 and/or 8, which Perforated the Left Side of the Turret	78
69. Impact Diagram, Target 34	80
70. Impact Two, Target 34, Penetration of Turret Ring between Hull and Turret, Armor Bulged, Turret Jammed	81
71. Impact Seven, Target 34, Perforation of the Left Hull Armor into the Bulkhead Stowage Area	81
72. Impact Diagram, Target 35	83
73. Commander Manikin, Target 35, Showing Damage from Perforations into the Fighting Compartment	84

LIST OF FIGURES (Continued)

Figure	Page
74. Gunner Manikin, Target 5, Showing Damage from Perforations into the Fighting Compartment	84
75. Loader Manikin, Target 35, Showing Damage from Perforations into the Fighting Compartment	85
76. Impact Nine, Target 35, Showing Perforation of Top Hull Armor Which Jammed the Turret	85
77. Impact Diagram, Target 36	87
78. Impact Thirty, Target 36, which Destroyed the Left #2 Roadwheel Hub	88
79. Impact Thirty-One, Target 36, which Damaged the Rim and Destroyed the Hub of the Left #1 Track Support Roller	88
80. Impact Forty-Seven, Target 36, which Destroyed the Left #5 Roadwheel Hub Bearings	89
81. Impact Diagram, Target 37	91
82. Impact Eight, Target 37, Perforations of Turret Ring which Jammed Turret	92
83. Impact Nine, Target 37, Perforations of Turret Ring Which Jammed Turret	92
84. Gunner Manikin, Target 37, Showing Damage from Impact 9, Loader Fragment Casualty	93
85. Loader Manikin, Target 37, Showing Damage from Impacts 9 and 19	93
86. Impact Diagram, Target 38	95
87. Impact Ten, Target 38, Showing Initial Impact on the Left #3 Track Support Roller	96
88. Impact Ten, Target 38, Showing Penetration of the Left Final Drive	96

LIST OF FIGURES (Continued)

Figure	Page
89. Impact Diagram, Target 39	98
90. Impact Twenty-Four, Target 39, which Destroyed the Left #1 Roadwheel Hub	99
91. Impact Seventeen, Target 39, which Shattered a Vision Block in the Commander Cupola and Wounded the Commander	99
92. Impact Diagram, Front and Side, Target 40	101
93. Impact Diagram, Top, Target 40	102
94. Impact Two, Target 40, Perforation of Left Hull into Driver's Compartment	103
95. Driver Manikin, Target 40, Showing Damage from Impact 2	103
96. Impact Thirty-Three, Target 40, which Destroyed the Left #1 Roadwheel Hub	104
97. Impacts Forty-Two and Forty-Five, Target 40, which Destroyed the Left #2 Roadwheel Hub	104
98. Impact Fifty-Seven, Target 40, which Destroyed the Left #3 Roadwheel Hub	105
99. Impact Sixty-One, Target 40, which Destroyed the Left #4 Roadwheel Hub	105
100. Impact Sixty-Eight, Target 40, which Perforated the Left Final Drive	106
101. Impact Thirty-Nine, Target 40, which Destroyed the Left #3 Track Support Roller	106
102. Impact Forty, Target 40, Contributor to Left #3 Track Support Roller Damage	107
103. Impact Fifteen, Target 40, which Perforated the Left Side of the Commander's Cupola	107

LIST OF FIGURES (Continued)

Figure	Page
104. Commander Manikin, Target 40, Showing Damage from Impact 15	108
105. Impact Three, Target 40, which Jammed the Turret so that it would not Traverse	108
106. Impact Diagram, Target 41	110
107. Impact Eighteen, Target 41, Perforation of Commander's Cupola, causing Casualties to Commander and Gunner	111
108. Impact Diagram, Target 42	113
109. Impact Seventeen, Target 42, Showing Destroyed End Connector	114
110. Impact Eighteen, Target 42, Showing Destroyed End Connector	114
111. Impact Diagram, Target 43	116
112. Impact Twenty-Five, Target 43, Showing Penetration of the Left Final Drive	117
113. Impact Twenty-Eight, Target 43, Showing Damage to Left Inside Drive Sprocket and Penetration of Left Final Drive	117
114. Impact Twenty-Two, Target 43, which Destroyed the Left #6 Roadwheel Hub	118
115. Impact Three, Target 43, which Perforated the Left Front Turret into the Fighting Compartment	118
116. Commander Manikin, Target 43, Showing Damage from Impact 3	119
117. Gunner Manikin, Target 43, Showing Damage from Impact 3	119
118. Impact Diagram, Target 44	121

LIST OF FIGURES (Concluded)

Figure		Page
119.	Impact Eleven, Target 44, which Perforated the Left Hull Armor into the Engine Compartment	122
120.	Impact One, Target 44, which Perforated the Left Top of the Turret and caused Commander and Gunner Casualties	122
121.	Impact Diagram, Target 45	124
122.	Impact Forty, Target 45, Severe Damage to Left #4 Roadwheel Hub, 100% Loss of Wheel	125
123.	Impact Thirty-Seven, Target 45, 100% Loss of Function of #2 Track Support Roller	125
124.	Impact Thirty-Eight, Target 45, Damage to #2 Track Support Roller, and 100% Loss of #5 Roadwheel Shock Absorber	126
125.	Impact One, Target 45, Top of Gun Tube Wall Perforated, Maximum Hole Dimension 37mm	126
A-1.	Array 3 Attack Aspect Summary	132

LIST OF TABLES

Table	Page
1. Array 3 Summary of A-10 Aircraft in Low Angle Gun Attack against Simulated Soviet Tank Company	4
2. Comparison of Ideal & Practical Test Conditions . . .	7
A-1. Array 13 Aircraft Attack Parameters	130

EXECUTIVE SUMMARY

Under the technical direction of the Combat Damage Assessment Committee (CDAC), the Combat Damage Assessment Team (CDAT) conducted test firings of the A-10/GAU-8 weapons system on 2 February 1979. The purpose of the test was to evaluate the effects of the GAU-8 30mm API anti-tank ammunition (LAVP lot number OL78D043-016, Honeywell) against realistically simulated Soviet Main Battle Tanks (MBTs). The tests were conducted against an array of 31 MBTs and four simulated ZSU-23/4 targets, deployed for an attack. The array simulated a three-company Soviet Tank Battalion with Anti-Aircraft Artillery (AAA) support. M-47 tanks loaded with 90mm TP ammunition, diesel fuel, lubricating oil, and crew manikins were used to simulate Soviet MBTs. Plywood mock-ups were used to simulate ZSU-23/4s. The pilots of the five A-10 aircraft used in the firings conducted their attacks at low altitudes and low dive angles thus simulating approach and attack below the altitude of effective engagement by the opposing air defense (AD) network and its fire control radar. The exercise included seven initial firing passes at relatively long range (approximately 6000 feet) against four simulated ZSU-23/4 targets in the Soviet tank formation, followed by shorter range firings on the tank targets.

The CDAC assessed the results of the firings against the tanks as follows:

Attack Parameters

The pilots of the attacking aircraft fired against the tank array at low dive angles from 10 frontal and 20 rear aspects. The attacks resulted in high obliquity impacts averaging 55 degrees from normal on the side surfaces of the hulls and turrets of the tanks. See Figure 6 for the layout of the tanks on the simulated battlefield, including the locations of companies A, B, and C in the Soviet tank battalion and a graphic view of the high obliquities offered by the side surfaces of the tanks.

Five A-10 aircraft attacked Company A from a left to right aspect averaging 321 degrees (0 degrees taken as front of tank with angles measured clockwise). The attack aspect chosen by the pilots was the most desirable from the viewpoint of inflicting catastrophic damage on the target tanks. Catastrophic damage results almost entirely from the internal effects of perforating projectiles. The projectiles fired at the frontal aspects, however, were presented with (1) the heavily armored frontal surfaces of the hulls and turrets, and (2) the less heavily armored side surfaces at high obliquities averaging approximately 51 degrees from the normal. The combination of heavy frontal armor and high side obliquities resulted in a low average of 0.04 penetrations per impact and the absence of any F-kills in Company A. The pilots of the attacking aircraft, however, compensated for the unfavorable attack aspect by accurate shooting at effective open fire ranges and

impacted the 10 tanks of the company with 366 projectiles. The pilots accomplished the results under realistic conditions of battlefield obscurity and destroyed the simulated Soviet tank company by cumulative external effects resulting in the assessment of eight 100% mobility kills.

Two A-10 aircraft attacked Company B from a right rear attack aspect averaging 154 degrees. The attack aspect chosen by the pilots was desirable from the viewpoint of inflicting catastrophic and mobility damage on Soviet T-62 tanks and probably later model tanks, e.g., T-72, T-80. The attack aspect was less desirable from the viewpoint of inflicting catastrophic damage on the M-47 tanks used in the test because of the uniquely exaggerated overhang at the rear of the turret and the large stowage box attached in turn on the overhang. Unlike the present M60A1 105mm gun tanks which have a large but relatively less pronounced overhang, unenclosed stowage bins, and carry 23 rounds of 105mm ammunition in the overhang, the M-47 overhang configuration includes no ammunition and serves as a protective spaced array of inert material. The projectiles fired at the right rear aspect thus were presented with (1) the spaced array at the rear of the turret shielding crew and ammunition in the fighting compartment, and (2) the side surfaces of the turrets and hulls at high obliquities averaging 54 degrees from the normal. The combination of the spaced array and exceptionally high side obliquities contributed to a moderately effective average of 0.11 perforations per impact and the fact that only one tank was catastrophically destroyed in the company. The pilots of the attacking aircraft, however, compensated for the unique toughness of the rear of the M-47 turret and the high side obliquities by placing an average of 26 projectiles on each of the eight tanks which were impacted in Company B (one tank was missed and one tank was not attacked). The large average number of impacts from the right rear aspect included perforations into the engine compartment and cumulative damage to the external suspension system which resulted in six 100 percent mobility kills in addition to the catastrophic kill.

Two A-10 aircraft attacked Company C from a left rear attack aspect averaging 225 degrees. As in the case of Company B, the pilots chose an attack aspect which was moderately desirable from the viewpoint of inflicting catastrophic damage on Soviet T-62 tanks but less desirable for causing catastrophic damage to M-47 tanks. The pilots compensated for the moderately desirable attack aspect from the viewpoint of catastrophic damage by relatively short accurate bursts at close range impacting all ten tanks, placing 336 projectiles on target, and causing six 100 percent mobility kills, two 100 percent firepower kills, and one catastrophic kill.

Weapon Effects

The pilots of the A-10 aircraft fired an estimated 2592 rounds

in approximately 6 minutes while making 30 passes against 30 different tanks. They achieved a total of 921 impacts consisting of 85 perforations through the armored envelopes and 832 hits on various exterior surfaces and components. The ratio of impacts to total rounds fired (921/2592) was 0.36, and the ratio of perforations to impacts (85/921) was 0.092. The pilots also made seven firing passes at the four simulated ZSU-23/4 self propelled guns of the Soviet tank battalion at ranges of engagement beyond those effective for the air defense cannons. Every simulated ZSU-23/4 was impacted by projectiles from the attacking aircraft, and the single target which did not burn was observed to have nine impacts on it.

Damage Assessment

The pilots of the A-10 aircraft attacked the simulated Soviet tank battalion for approximately six minutes and caused the following damage:

(1) From the overall viewpoint of the battalion. Within six minutes of the time of the opening of the air attack against the tanks proper, the Soviet tank battalion, simulated by combat loaded M-47 tanks, was destroyed as an effective combat unit. The CDAT based its assessment of the destruction of the battalion on the following physically observed results:

(a) Seventy-one percent of the tank strength of the battalion was totally immobilized due to various combinations of internal fires and explosions, crew casualties, transmission, engine, and fuel tank damage, and cumulative damage to exterior suspension components. Every totally immobilized tank also suffered either total or significant firepower damage.

(b) An additional 13 percent of the tank strength of the battalion suffered damage resulting in the total loss of firepower.

(2) From the viewpoint of the individual tanks. The most noteworthy positive damage effects were those leading to the assessment of 20 100% M-Kills. Such damage comprised crew casualties and destruction of interior and exterior mobility components, e.g., engines, transmission, final drives, road wheels, road wheel hubs, track connectors, etc. The most noteworthy negative damage effects were those associated with K-Kills. Many of the tanks were impacted by projectiles which perforated the internal diesel fuel tanks but failed to cause fires which in turn would have catastrophically damaged the tanks. The CDAT takes the position that the number of K-Kills was unrealistically low due to the following challenges in test realism:

(a) The diesel fuel and lubricating oil in the target tanks could not be maintained at realistic temperatures and pressures for tanks with engines running. The actual temperature of the material was at the unrealistically low value of approximately 28°F during the

winter firing test. The temperature of the diesel fuel next to hot engine components would have been considerably greater as would the temperature of the oil. The higher temperatures would have increased significantly the susceptibility of the fuel and oil to ignition by increasing the vapor pressure in any area exposed to air.

(b) The diesel fuel could not be simulated as realistically in movement, i.e., sloshing around, during the firing test thus also reducing the vapor pressure within the fuel tanks at the surface of the fuel.

Test Conditions:

The target tanks were positioned in open, flat desert terrain with no cover and little concealment. Aerial weather conditions were excellent, with unlimited ceiling and visibility. Shortly after the initial firing, clouds of white dust from projectile impacts were evident. Such conditions effectively simulated the actual target obscuration which would have been encountered by pilots in combat.

Overall Comments on Results

The CDAT assessed an average probability of tank neutralization (total loss of mobility or firepower) per pass of 87%. This was based on 26 tanks neutralized after 30 passes. Individual assessments, contained in Table I, show that after A-10 attacks, the bulk of the simulated tank battalion was immobilized, and its combat power reduced by 87%. The distribution of these losses (9 tanks in Company A, 8 tanks in Company B, and 9 tanks in Company C indicates that considerable delay for the reorganization of battle-effective tanks and crews would be involved before the battalion could continue its mission at greatly reduced strength.

The kills which were achieved can be attributed to fires and explosions caused by perforated fuel tanks or cartridge cases, damage to tracks, suspension, and drive trains, jammed turrets, and crew casualties.

Table 1. Array 3 Summary of A-10 Aircraft in Low Angle Gun Attack versus Simulated Soviet Tank Company (Page 1 of 2)
(2 FEBRUARY 1980)

TANK NO.	A-10 PRIMARY PASS*	A-10 APPROACH		A-10 ATTACK		G/P EFFECTS		DAMAGE			TANK IMMOB	TANK ASPECT (DEGREES)	
		SPEED (FPS)	ALT (FT)	OPEN FIRE RANGE	DIVE ANGLE	ROUNDS (EACH)	IMPACTS (EACH)	PERFS (EACH)	M %	F %			K %
36	5/2	586	463	2699	4.0	97	50	---	100	---	---	Yes	333
37	5/1	601	463	2354	4.0	72	43	4	80	100	---	No	325
38	4/3	621	513	3294	6.0	89	10	---	100	---	---	Yes	324
39	3/4	557	438	2334	3.0	100	30	---	100	50	---	Yes	327
40	2/4	583	363	2487	4.0	100	71	2	100	100	---	Yes	320
41	1/4	591	463	3677	3.0	107	41	1	65	95	---	No	318
42	4/2	638	363	3501	2.0	101	23	---	100	---	---	Yes	303
43	3/3	637	363	2155	3.0	70	30	5	100	100	---	Yes	313
44	2/3	633	338	2589	3.0	60	13	2	100	95	---	Yes	322
45	1/3	635	373	2803	2.0	85	55	---	100	10	---	Yes	322
17	2/9	519	333	2526	2.0	88	47	6	---	---	100	Yes	133
19	1/9	552	363	3766	2.0	105	18	1	100	---	---	Yes	143
20	2/8	532	263	2315	2.0	59	19	1	100	---	---	Yes	128
21	1/8	557	363	3160	0.0	108	24	1	75	100	---	No	146
22	2/7	544	363	2536	2.0	66	25	---	100	---	---	Yes	156
2	1/5	583	363	3186	0.0	107	18	5	100	---	---	Yes	188
23	1/7	571	353	2967	1.0	107	36	4	100	---	---	Yes	164
24	2/6	544	263	2607	2.0	40	---	---	***MISSED***	---	---	No	---
25	2/2	---	---	---	---	---	---	---	NOT ATTACKED	---	---	---	---
26	1/6	559	353	3173	0.0	107	16	3	100	---	---	Yes	166

COMPANY A

COMPANY B

Table 1. (Concluded)

TANK NO.	A-10 PRIMARY PASS*	A-10 APPROACH		A-10 ATTACK		GUN EFFECTS		DAMAGE			TANK IMMOB	TANK ASPECT (DEGREES)
		SPEED (FPS)	ALT (FT)	OPEN FIRE RANGE	DIVE ANGLE	ROUNDS IMPACTS (EACH)	PERFS (EACH)	M %	F %	K %		
27	4/8	564	463	2758	7.0	85	14	10	---	---	No	198
28	3/9	523	463	2102	8.0	79	53	90	100	---	No	237
29	4/7	587	363	2558	4.0	73	39	100	---	---	Yes	215
30	3/8	537	413	2173	4.0	83	50	100	100	---	Yes	228
31	3/7	540	363	2111	3.0	82	50	100	100	---	Yes	228
32	4/5	584	263	4776	4.0	129	18	---	---	100	Yes	237
33	3/6	557	463	2263	5.0	82	33	100	95	---	Yes	232
34	4/4	601	363	3061	3.0	92	16	---	100	---	No	246
35	3/5	584	563	2129	8.0	75	51	100	100	---	Yes	232
4	4/6	587	463	2630	6.0	78	12	100	---	---	Yes	193
BN CO	7	564	263	2897	0.0	66	14	20	---	---	No	167

Applicable

Totals:

Averages:

2592 919 83
86.4 30.6 2.8

22

- 2 tanks catastrophically damaged
- 5 tanks immobilized and silenced
- 4 tanks immobilized firepower degraded
- 11 tanks immobilized only
- 3 tanks silenced, mobility seriously degraded
- 1 tank silenced only
- 3 tanks degraded mobility and/or firepower
- 1 tank attacked but not damaged
- 1 tank not attacked

26 tanks neutralized

*1/1 means pilot 1, pass 1; 2/2 means pilot 2, pass 2; etc.

TEST PHILOSOPHY

To generate realistic data, the CDAC/CDAT teams employed an empirical technique of destructive testing of actual target tanks. Accordingly, the experimental setup of 2 February, 1979 involved an attack by the A-10/GAU-8 systems upon a multi-target, tactically arrayed tank formation simulating a three-company Soviet tank battalion. Except for following an established tactical doctrine, no constraints were placed upon the attacking pilots in order to ensure maximum realism possible. Table 2 lists factors that would have been ideal in that test, and the practical set up that was achieved.

SIMULATED GROUND COMBAT SITUATION

The firing test of 2 February, 1979 simulated the attack by five A-10 aircraft against a Soviet tank battalion. The CDAC hypothesized the Soviet tank battalion to be composed of three ten-tank companies, and a battalion commander's tank. Upon meeting heavy resistance, the battalion deployed into an appropriate combat formation to reduce resistance, and to form an optimum base for offensive action.

A Soviet tank battalion, which is simulated in the firing test, would probably have other units attached to it for support. Such units might include any or all of the following elements: (1) motorized rifle company (2) engineer detachment (3) chemical defense specialists (4) 122mm howitzer battery (5) and air defense support elements simulated in this test by four plywood ZSU-23/4 mockups. The tank formation was arranged with one company in front and two in the rear, simulating an initial assault posture. The targets used in the firing test were US M-47 tanks, largely intact, containing crew manikins, and stowed with ammunition, fuel, and oil. The tanks were not maneuvered during the firing test; the formation remained essentially a stationary snapshot of the battalion.

TABLE 2. Comparison of Ideal & Practical Test Conditions

<u>Ideal Test Parameters</u>	<u>Practical Test Parameter</u>
<p>1. <u>Air Attack Realism</u></p> <ul style="list-style-type: none"> a. Actual A-10/GAU-8 configuration b. 30mm APIT ammunition c. European weather & terrain d. Optimum open-fire ranges (2000 ft) e. Low altitude attack angle (<-6 degrees) 	<p>1. <u>Air Attack Realism</u></p> <ul style="list-style-type: none"> a. Actual A-10/GAU-8 configuration b. 30mm APIT ammunition c. Nevada weather & desert terrain d. Open-fire ranges (2820 feet average) e. Low altitude attack angle (-3.23 degrees average)
<p>2. <u>Air Defense Realism</u></p> <ul style="list-style-type: none"> a. Automatic cannon firing at aircraft b. Missile systems firing at aircraft c. Small arms firing at aircraft d. AD suppression by aircraft 	<p>2. <u>Air Defense Realism</u></p> <ul style="list-style-type: none"> a. Low altitude, low angle, minimum exposure attacks against assumed AD system b. Low altitude, low angle, minimum exposure attacks against assumed AD system c. Low altitude, low angle, minimum exposure attacks against assumed AD system d. Suppression of four (4) simulated ZSU-23/4 targets at an average 6,000 feet open-fire range.
<p>3. <u>Threat Targets and Doctrine</u></p> <ul style="list-style-type: none"> a. Soviet T62/T64/T72 high fidelity tank targets b. Combat loads, stowed in Soviet T62/T64/T72 tanks c. Realistic crew station postures d. Dynamic combat formation e. Maneuvering, evasive targets 	<p>3. <u>Threat Targets and Doctrine</u></p> <ul style="list-style-type: none"> a. Soviet tanks, simulated by US M-47 tanks b. Combat loads, stowed in US M-47 tanks c. Wooden crew manikins d. Static combat formation e. Stationary targets

TARGET TANKS

The most effective targets, available in sufficient numbers to simulate Soviet T-55 and T-62 (Figure 1) tanks were the US M-47 tanks. Both Soviet tank models are similar in armor protection to the M-47. With appropriate purging of the gasoline fuel system of the US tanks, the CDAT managed to field a target similar in survivability to the T-55 and T-62 tanks in terms of their ignitable internal material. Few data are available on the armor protection, and the arrangement of internal components in the Soviet T-64 and later model tanks. The decision was made, accordingly, to simulate the earlier model Soviet tanks with the readily available US tanks.

The M-47 tanks, used as targets, were in excellent condition for damage assessment. The exterior components were complete, and the tanks have proven to be effective targets for assessment of exterior mobility damage. Interior components were less complete. All of the most essential items were present, e.g., main gun, engine, transmission, fuel tanks, ammunition racks, etc., but other items such as oil coolers, range finders, vision devices, and radios, were not uniformly installed in all tanks.

The following sensitive internal items which contributed to catastrophic kills, and to high percentage M- and F-kills were placed in test tanks:

<u>Generic Sensitive Item</u>	<u>Test Item</u>
1. Ammunition -----	US Cartridge, 90-mm TP-T
2. Fuel -----	Number 2 Diesel
3. Oil -----	Oil in Engine, Transmission and Drive Components.
4. Personnel -----	Articulated Plywood Manikins

TEST RESULTS

Tests consisted of exposing the ammunition, gun, aircraft, pilots, and combat-arrayed and loaded tanks to several minutes of combat simulation. The key elements in the scenario were:

1. 30mm API ammunition, Honeywell lot number OL78D043-016.
2. General Electric GAU-8 Gatling gun.
3. Fairchild Republic A-10 ground support aircraft.
4. USAF combat pilots
5. US M-47 main battle tanks, combat-loaded.

The combat simulation itself comprised the aerial fire and appropriate maneuvers of the attacking A-10 aircraft.

Aerojet Ordnance and Manufacturing Company personnel provided the industrial support required to repair, refurbish, and field the tank targets. The CDAT applied research techniques required to describe weapon effects and combat damage. The basic materiel used in tests, i.e., aircraft, target tanks, ZSU-23/4 mockups, and projectiles are illustrated in Figures 2, 3, 4 and 5. The targets were arrayed in the tactical formation of a Soviet tank battalion, shown in Figure 6.

The A-10 pilots simulated target acquisition with the help of a forward air controller. They attacked the tanks at low angles and below the minimum altitude required by the opposing air defense missiles and gun systems for effective acquisition of threats.

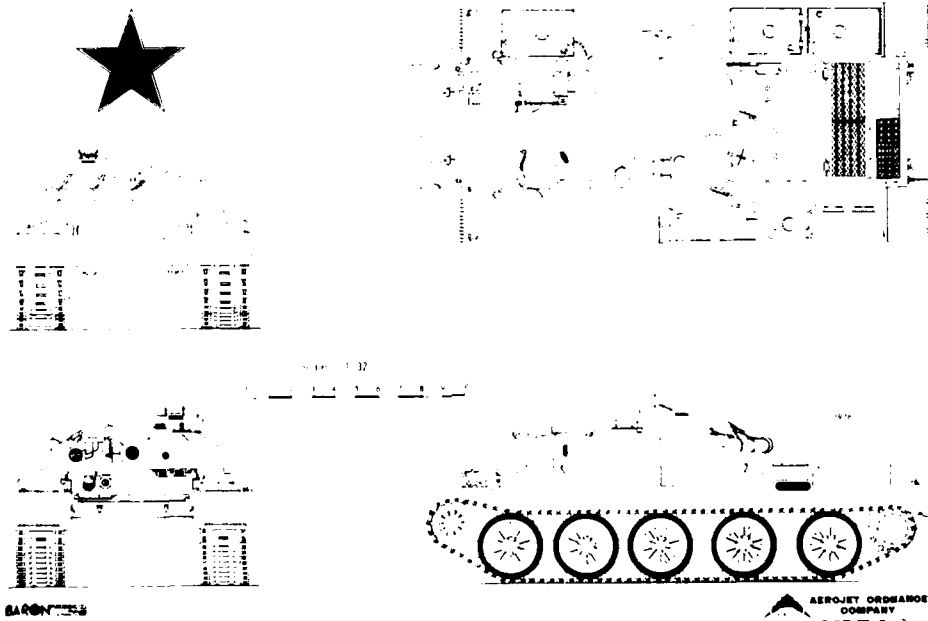

FIGURE 1. Russian T62 Medium Tank



FIGURE 2. U.S.A.F. Fairchild Republic A-10 Close Air Support Aircraft.



FIGURE 3. United States M-47 Combat Tank.

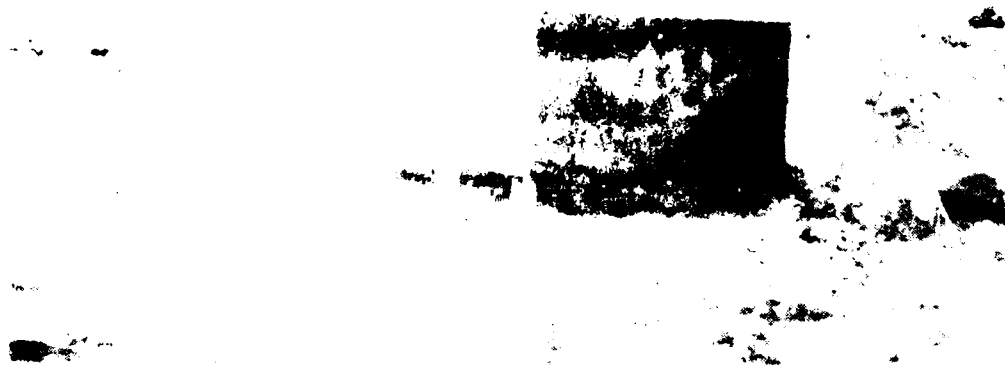
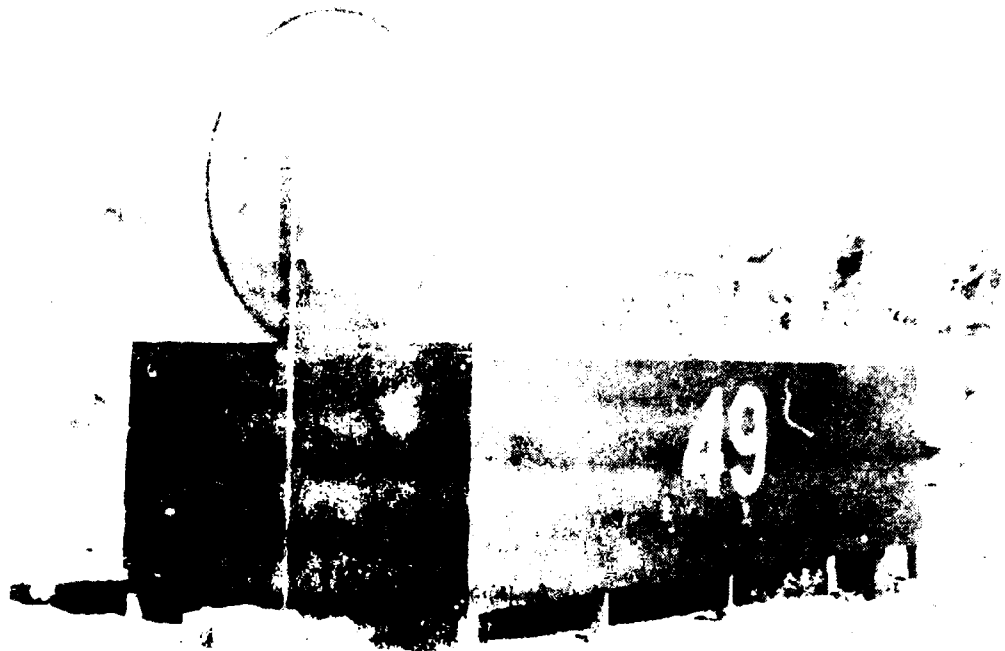

FILE NO. 100-2374 AWA (11).

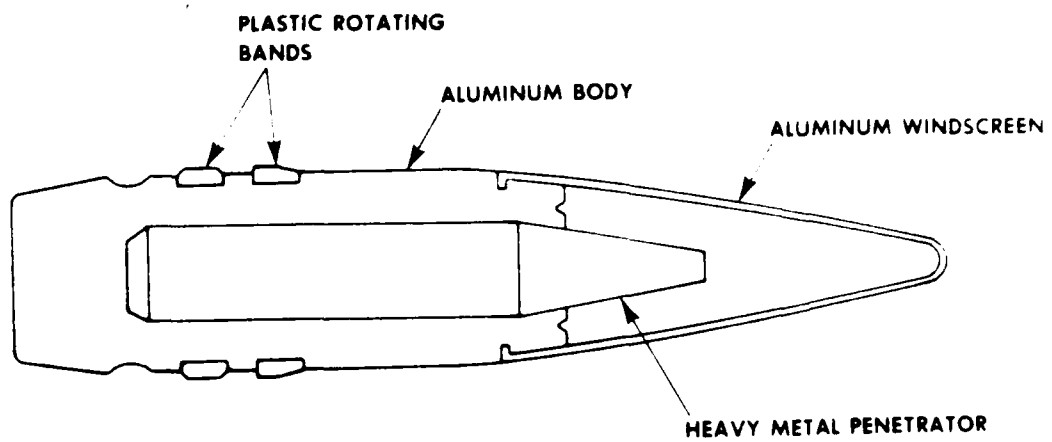

FIGURE 5. Cross-section of a 30mm Armor Piercing Incendiary (API) Projectile.

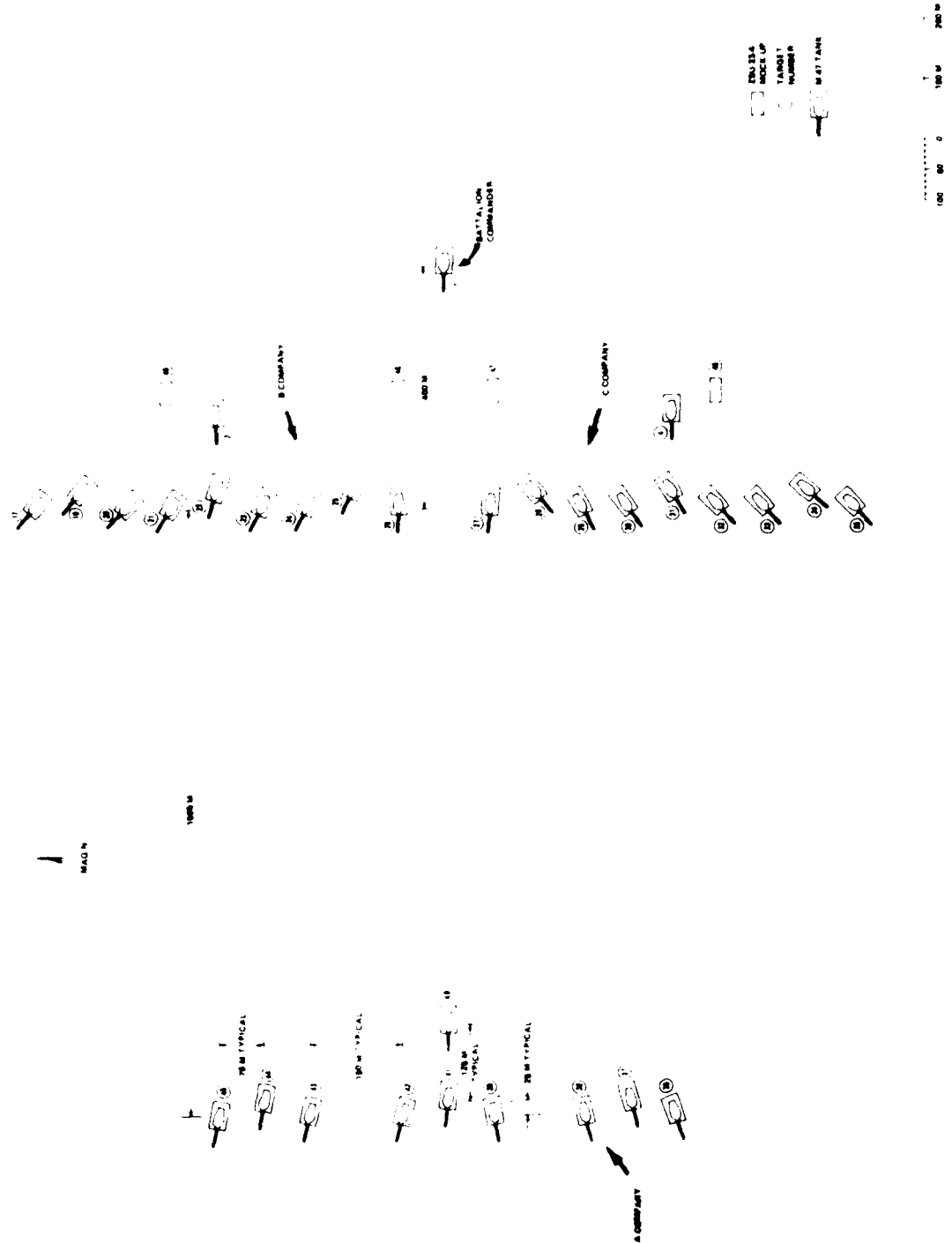

FIGURE 6. Mission A-3, Simulated Target Layout of Soviet Tank Battalion.

DAMAGE ASSESSMENT

The damage assessed on each tank is presented in the following section. The tanks are arranged in order of the identification numbers on the turrets. Data presented include the following:

Damage Assessment

Location and breakdown of Impacts Diagrammed as follows:

- Hits
- △ Perforations

Supportive Photography of Damage Assessment

No consideration was given to tanks 24 and 25, which were not hit, and therefore are not included in the Damage Assessment section.

Terms used in the damage assessment summaries are defined in Appendix B.

Impacts on targets were numbered arbitrarily and sequentially for identification purposes, first at the turret level, then at the hull level. If additional impacts were discovered during the combat damage assessment, as was sometimes the case, they were given the next sequential number without an attempt to correct the sequence. THE READER IS CAUTIONED THAT THIS NUMBERING SYSTEM HAS NO RELATIONSHIP WHATSOEVER TO THE SEQUENCE OF PROJECTILE ARRIVALS ON THE TANK, OR TO ANY PORTION OF THE BURST IMPACTING THE TANK.

TARGET TANK NUMBER 2 DAMAGE SUMMARY

1. Description:

The attacking A-10 aircraft impacted target tank number 2 with 18 projectiles, fired from an aspect angle of 188 degrees (rear) during one pass at low altitude and low dive angle, while expending 107 rounds.

2. Kill Assessment:

100% M-Kill, resulting from the following projectile impacts, shown in Figure 7:

a. Perforations	:	5
b. Significant Impacts *	:	4
c. Insignificant Impacts*	:	<u>9</u>

Total Impacts : 18

3. Rationale for Kill Assessment:

Five of the impacts (numbers 6, 7, 8, 9, and 11) shown in Figures 8, 9, 10, 11, and 12, respectively, achieved perforations of the armored envelope. Behind-the-plate effects of Impact 6, shown in Figure 8, could not be determined because of the location of the strike. The remaining perforations could have resulted in a mobility kill through penetrations into the transmission case, or rupture of transmission oil cooler lines. Impacts 2, 3, 4, and 18 made contributions to the kill through minor damage to the track and suspension system.

* For qualification of these terms, see Appendix B, "DEFINITIONS".

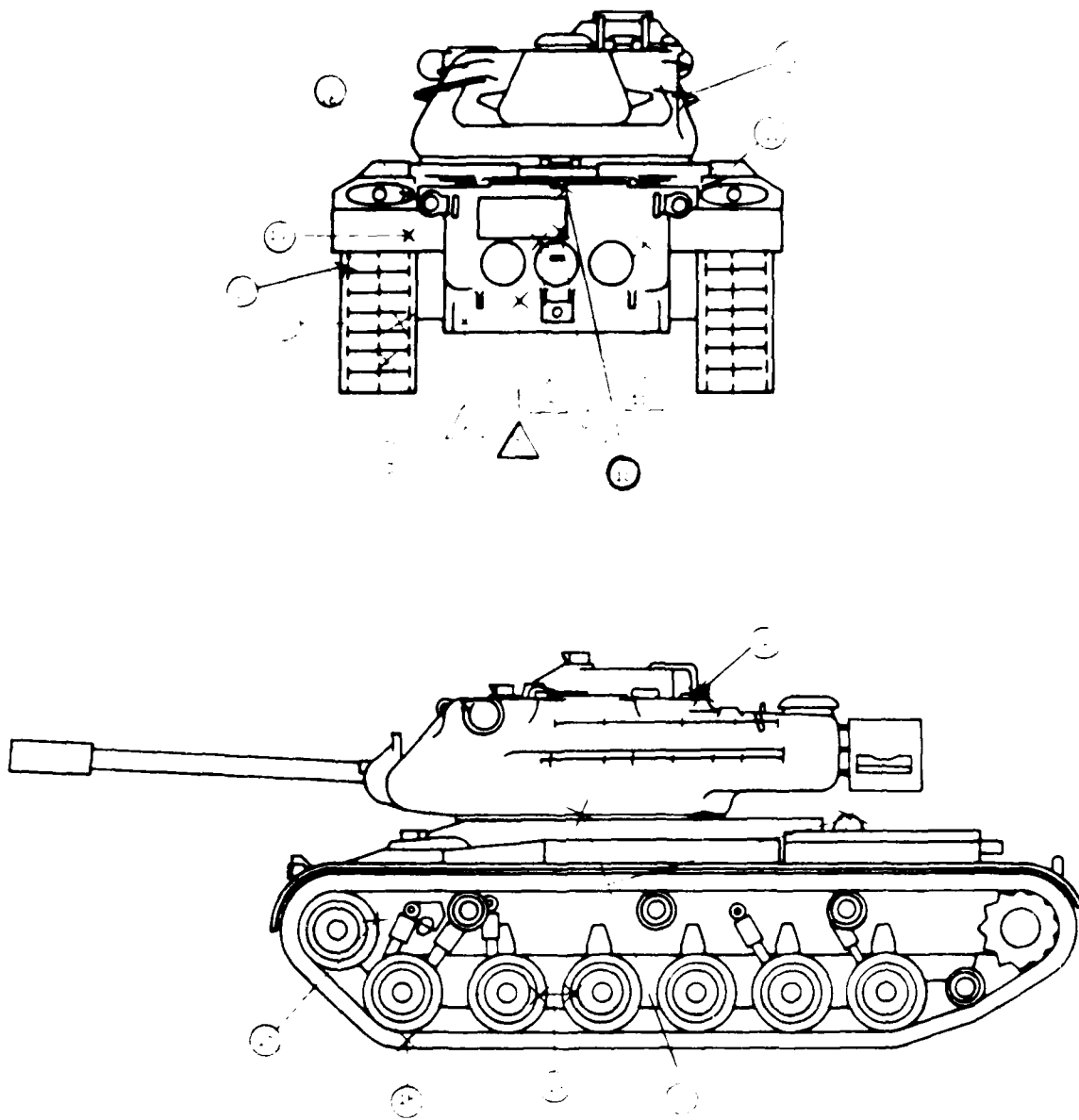
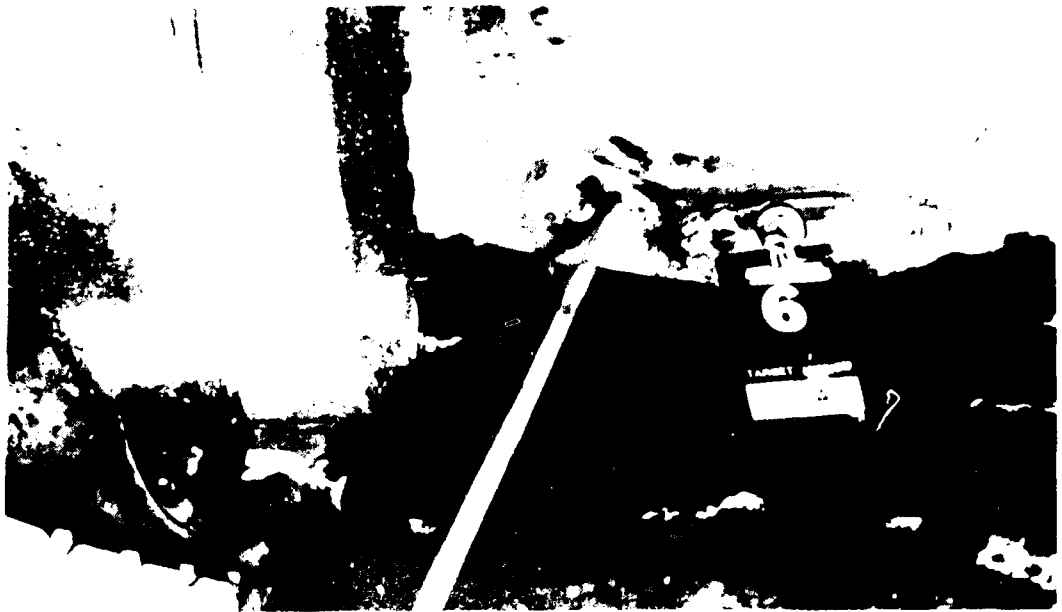
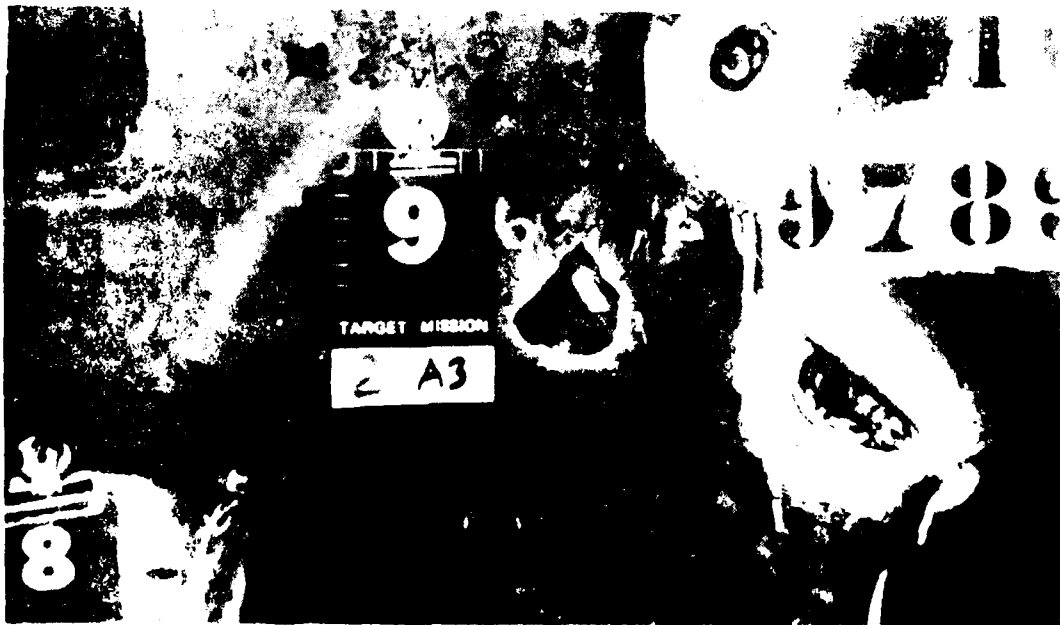

FIGURE 7. Impact Diagram, Target 2.





Target Mission 2 A3



Target Mission 2 A3



FIGURE 12. Impact Eleven, Target 2, Perforation of Rear Hull Armor (Transmission Oil Cooler Line was penetrated, causing oil leak).

TARGET TANK NUMBER 4 DAMAGE SUMMARY

1. Description:

The attacking A-10 aircraft impacted target tank number 4 with 12 projectiles, fired from an aspect angle of 193 degrees (rear) during one pass at low altitude and low dive angle, while expending 78 rounds.

2. Kill Assessment:

100% M-Kill, resulting from the following projectile impacts, shown in Figure 13:

a. Perforations	:	0
b. Significant Impacts	:	3
c. Insignificant Impacts:		<u>9</u>

Total Impacts	:	12
---------------	---	----

3. Rationale for Kill Assessment:

Impact 5, shown in Figure 14, destroyed the adjusting idler hub in the left track. Two other impacts contributed to the kill through minor damage to the track.

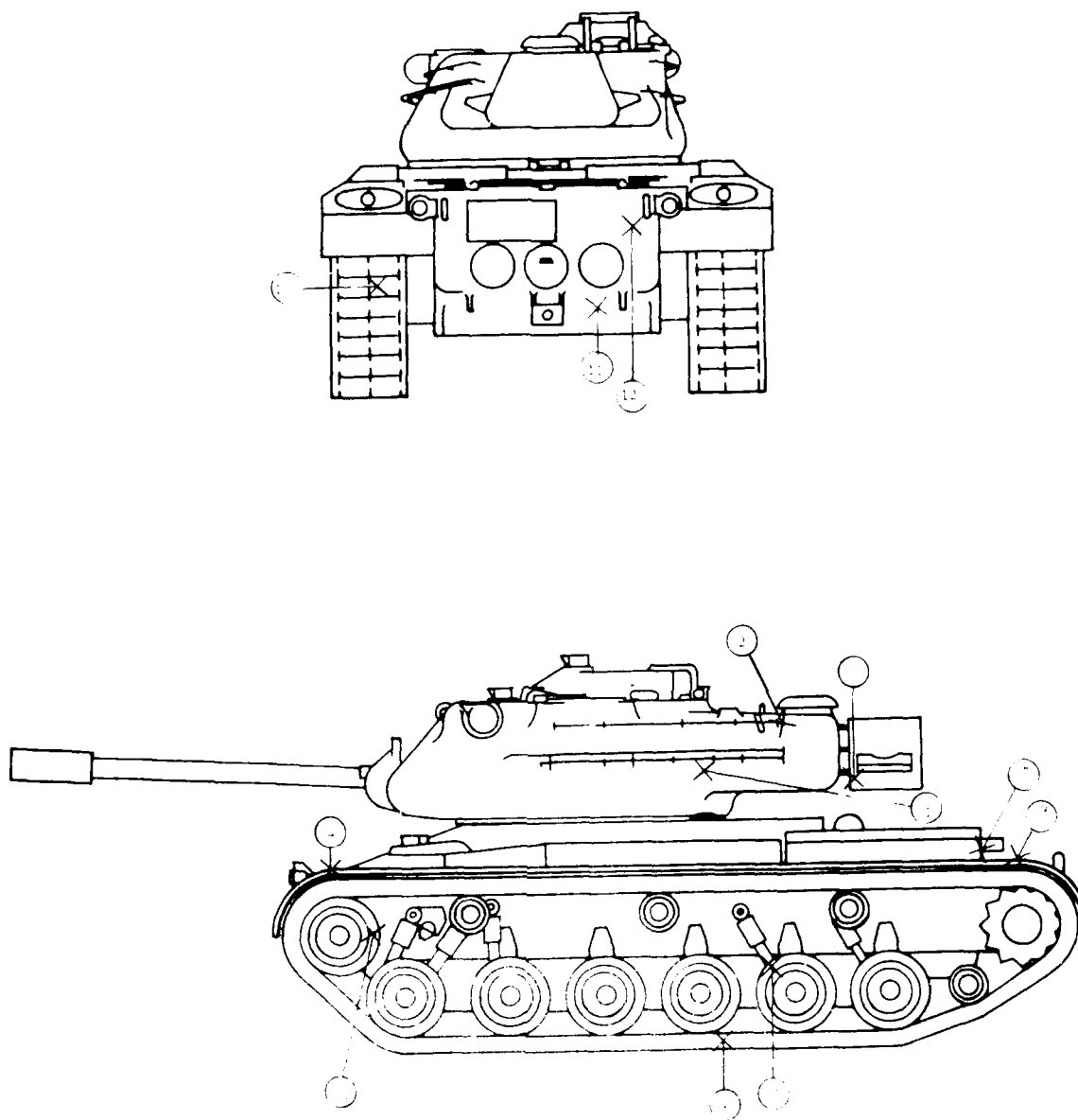

FIGURE 13. Impact Diagram, Target 4.

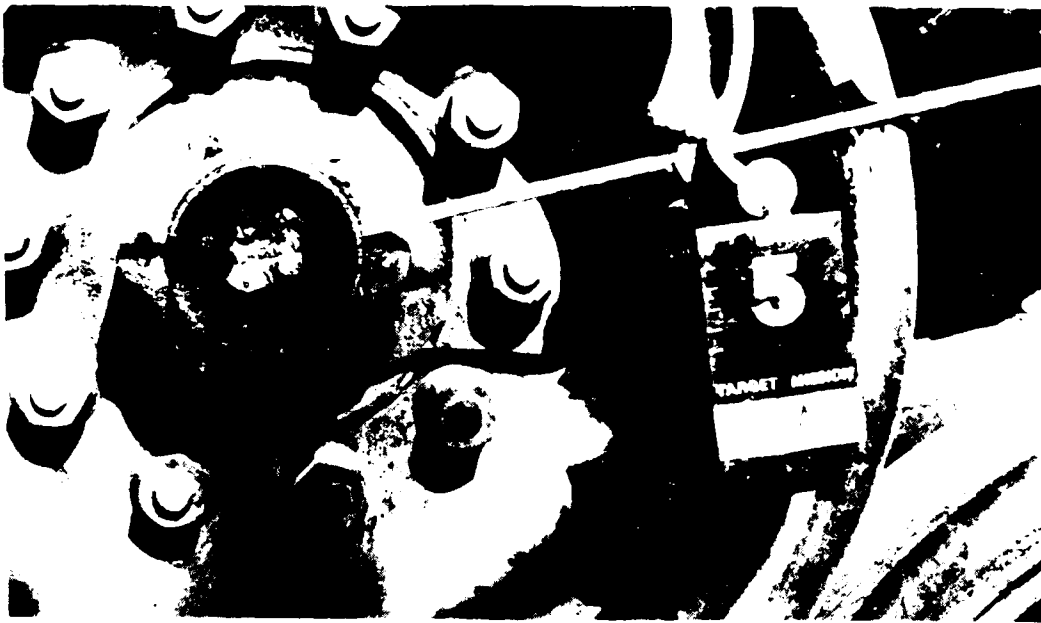

FIGURE 14. Impact Five, Target 4, Showing restricted Adjusting Idler hub in the Left Track.

TARGET TANK NUMBER 7 DAMAGE SUMMARY

1. Description:

The attacking A-10 aircraft impacted target tank number 7 with 14 projectiles, fired from an aspect angle of 167 degrees (rear) during one pass at low altitude and low dive angle, while expending 66 rounds.

2. Kill Assessment:

20% M-Kill, resulting from the following projectile impacts, shown in Figure 15:

a. Perforations	:	0
b. Significant Impacts	:	7
c. Insignificant Impacts:		<u>7</u>

Total Impacts	:	14
---------------	---	----

3. Rationale for Kill Assessment:

Mobility was estimated to have been degraded by 20%, due to cumulative damage to the track and suspension system resulting from seven hits. Impact 9, shown in Figure 16, is representative of the most severe damage inflicted during this attack pass.

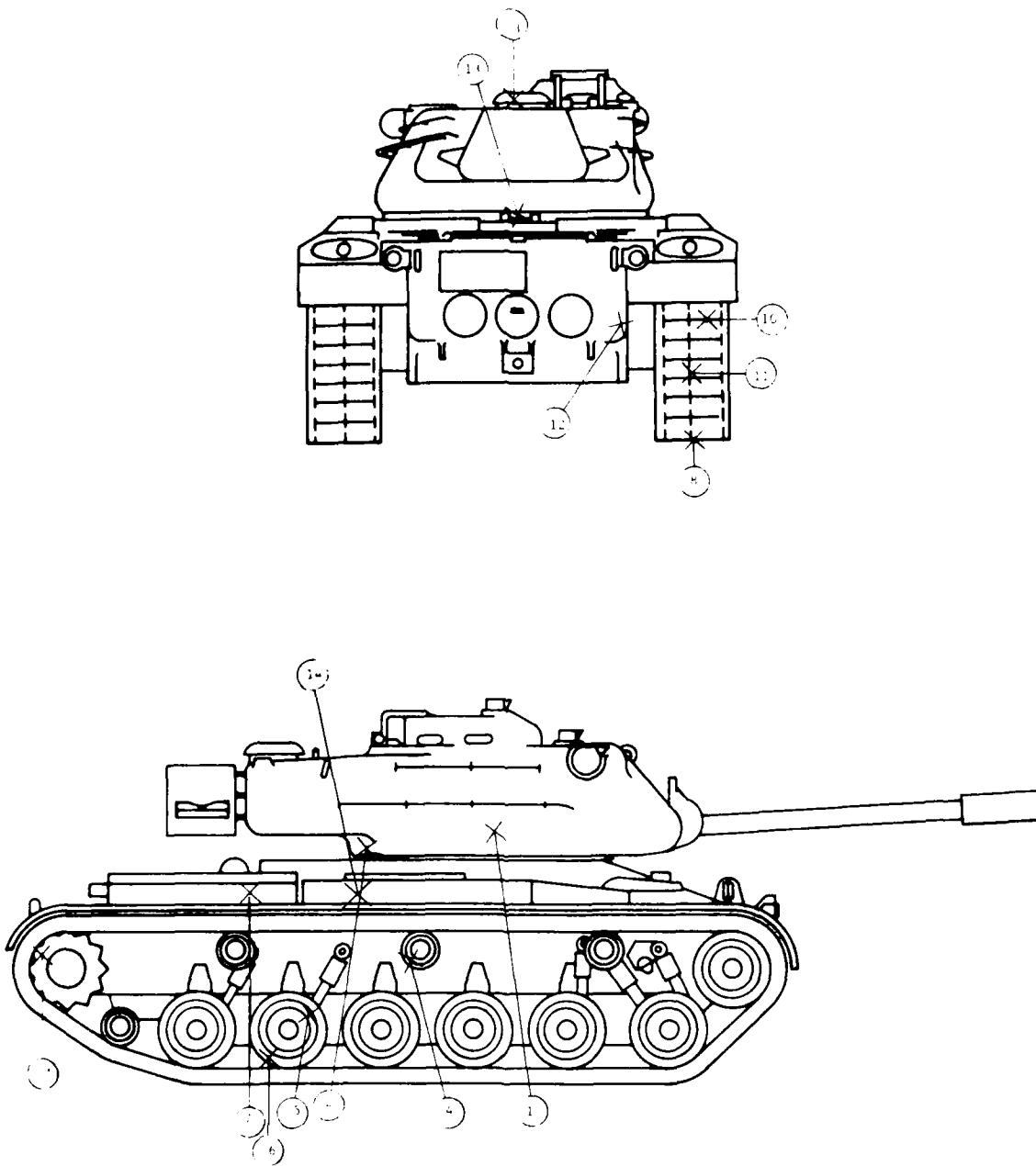

FIGURE 15. Impact Diagram, Target 7.



FIGURE 16. Impact Nine, Target 7, Showing Leastrail and Connector, Damaged Track Shoe Pins, and Broken Right Drive Sprocket.

TARGET TANK NUMBER 17 DAMAGE SUMMARY

1. Description:

The attacking A-10 aircraft impacted target tank number 17 with 47 projectiles, fired from an aspect angle of 133 degrees (right rear) during one pass at low altitude and low dive angle, while expending 88 rounds.

2. Kill Assessment:

100% K-Kill, resulting from the following projectile impacts shown in Figure 17:

a. Perforations	:	6
b. Significant Impacts	:	**
c. Insignificant Impacts:		<u>**</u>

Total Impacts : 47

**Omitted - Catastrophic fire and explosion overrode other damage.

3. Rationale for Kill Assessment:

This target did not immediately burst into flame after the attack pass, but was observed to be burning approximately six minutes later.

The right side of the turret was perforated by impacts 5, 6, and 7, shown in Figures 18, 19, and 20, respectively. Any of these impacts was capable of wounding or killing all personnel in the fighting compartment and, possibly, of igniting propellant of rounds stowed in the ready racks. Impact 4, which perforated the top of the turret at the loaders station, contributed to damage in the fighting compartment.

The rear hull was perforated by Impacts 41 and 42, which perforated the transmission case and severed an oil cooler line. Either of these impacts could have ignited oil in the transmission compartment.

A small fire, which could not be extinguished by the crew due to casualties, provides the best scenario for assessment of a K-Kill. The most likely place of origin of the fire is the transmission/engine compartment.

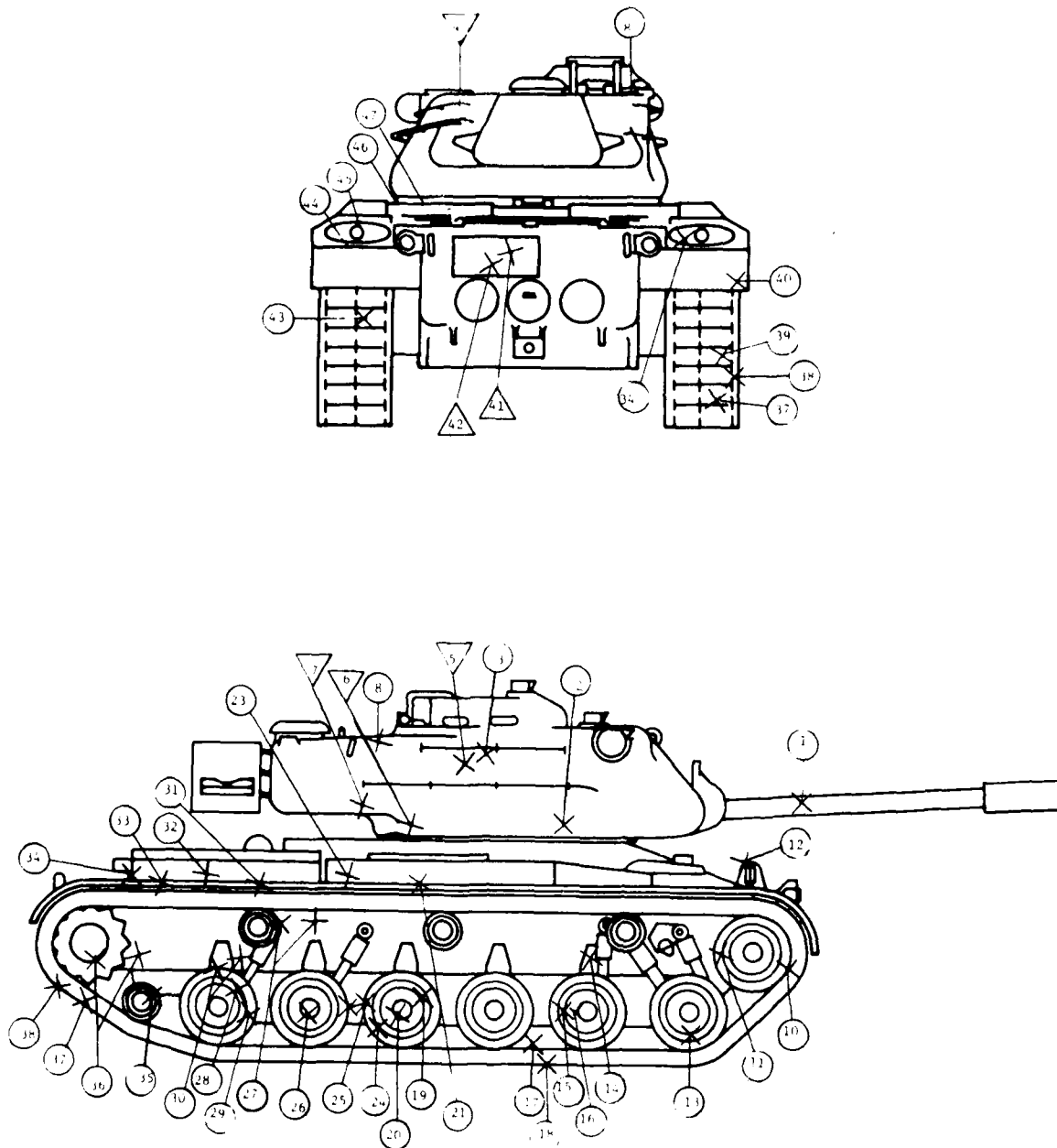

FIGURE 17. Impact Diagram, Target 17.



FIGURE 12. Impact of Target 17, Perforation of Right Side of Target.



FIGURE 13. Impact of Target 17, Perforation of Right Side of Target.



FIGURE 20. Impact Seven, Target 17, Perforation of right Side of Turret.

TARGET TANK NUMBER 19 DAMAGE SUMMARY

1. Description:

The attacking A-10 aircraft impacted target tank number 19 with 18 projectiles, fired from an aspect angle of 143 degrees (right rear) during one pass at low altitude and low dive angle, while expending 105 rounds.

2. Kill Assessment:

100% M-Kill, resulting from the following projectile impacts, shown in Figure 21:

a. Perforations : 1
b. Significant Impacts : 2
c. Insignificant Impacts: 15

Total Impacts : 18

3. Rationale for Kill Assessment:

Impact 8 (Figure 22) perforated the center access door at the rear of the hull, and penetrated the transmission case. (NOTE: The armored center access door had been replaced with one of lesser steel thickness. CDAT judgement was that this substitution made little difference in the results).

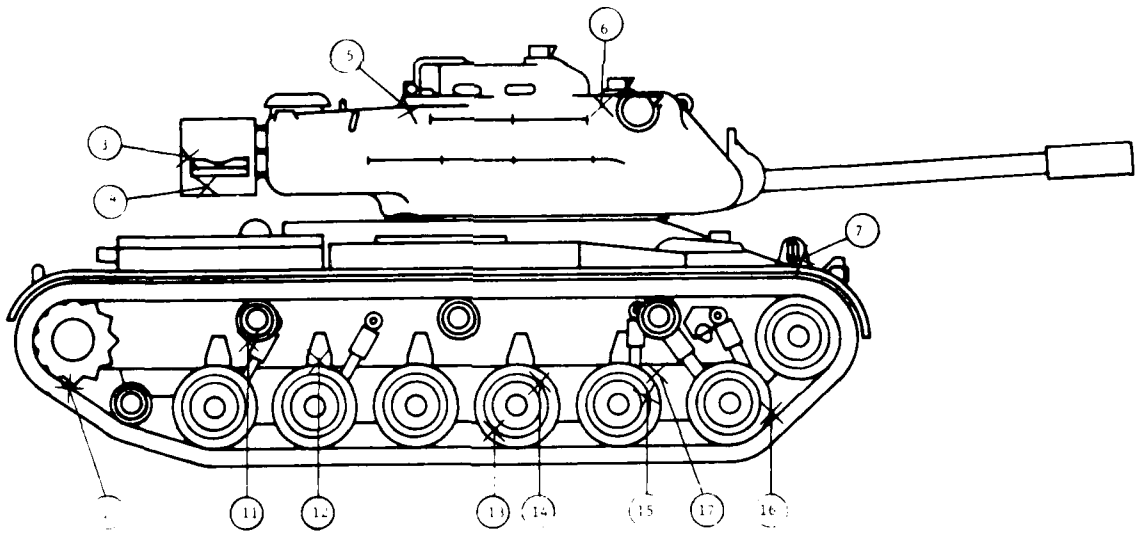
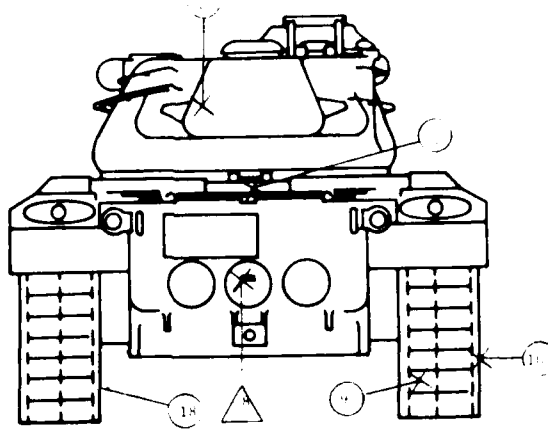

FIGURE 21. Impact Diagram, Target 19.



FIGURE 22. Impact Eight, Target 19, Perforation of Center Access Door into Transmission Compartment, and Penetration into the Transmission Case.

TARGET TANK NUMBER 20 DAMAGE SUMMARY

1. Description:

The attacking A-10 Aircraft impacted target tank number 20 with 19 projectiles, fired from an aspect angle of 128 degrees (right side) during one pass at low altitude and low dive angle, while expending 59 rounds.

2. Kill Assessment:

100% M-Kill, resulting from the following projectile impacts, shown in Figure 23:

a. Perforations	:	1
b. Significant Impacts	:	6
c. Insignificant Impacts:		<u>12</u>

Total Impacts	:	19
---------------	---	----

3. Rationale for Kill Assessment:

Impact 9 (Figure 24) perforated the right hull and penetrated the right fuel tank, causing a leak. Impacts 7, 8, 13, 14, 15, and 17 contributed to the kill through minor damage to the track and suspension system. In the judgement of the Combat Damage Assessment Team, the hole through the fuel tank, which was located only inches from the bottom would have filled the space under both the engine and fighting compartments with fuel and forced the evacuation of the tank.

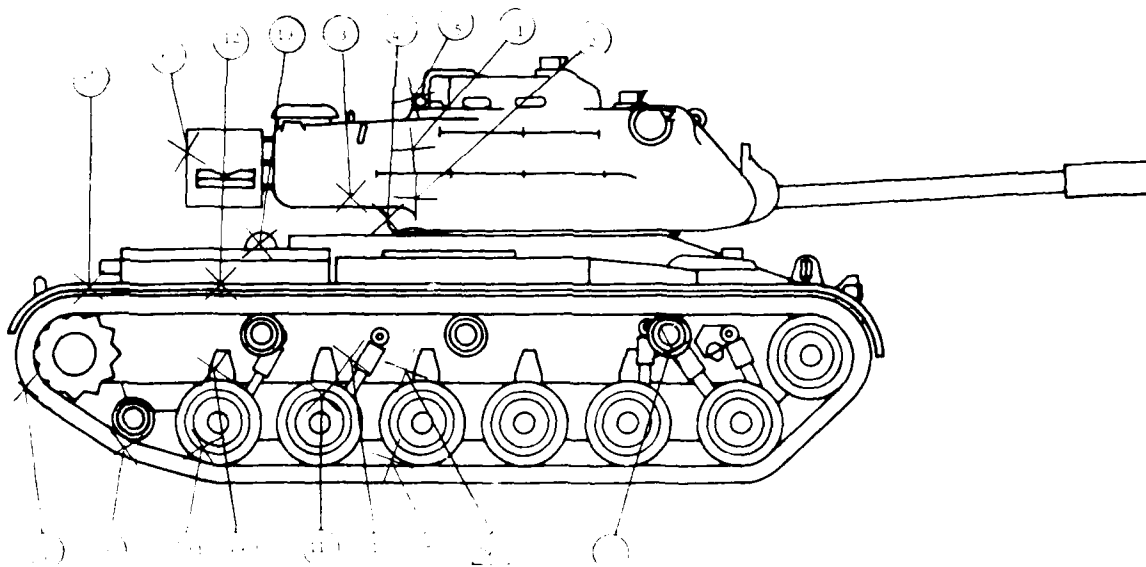
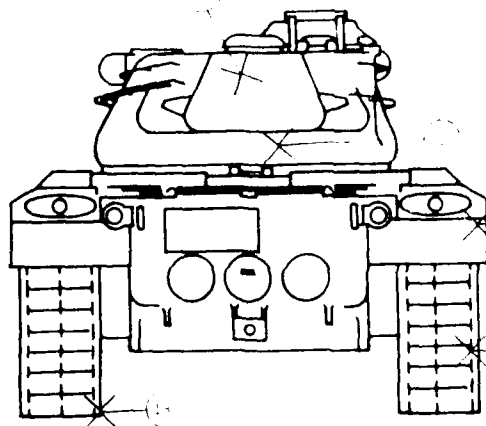

FIGURE 23. Impact Diagram, Target 20.



FIGURE 24. Impact Nine, Target 20, Perforation of the Hull Armor and Penetration into the Right Fuel Tank.

TARGET TANK NUMBER 21 DAMAGE SUMMARY

1. Description:

The attacking A-10 aircraft impacted target tank number 21 with 24 projectiles, fired from an aspect of 146 degrees (right rear) during one pass at low altitude and low dive angle, while expending 108 rounds.

2. Kill Assessment:

75% M-Kill and 100% F-Kill resulting from the following projectile impacts, shown in Figure 25:

a. Perforations	:	1
b. Significant Impacts	:	5
c. Insignificant Impacts:		<u>18</u>

Total Impacts	:	24
---------------	---	----

3. Rationale for Kill Assessment:

- a. M-Kill: An overall 75% M-Kill was assessed, based primarily (65%) on crew casualties (tank commander and gunner) caused by impacts 6 and 9, shown in Figures 26 and 27, respectively, and secondarily (10%) on cumulative damage to the track and suspension system caused by three other impacts.
- b. F-Kill: 100% F-Kill was due to crew casualties from impacts 6 and 9, and to impact 7 (Figure 28) which jammed the turret, preventing it from traversing.

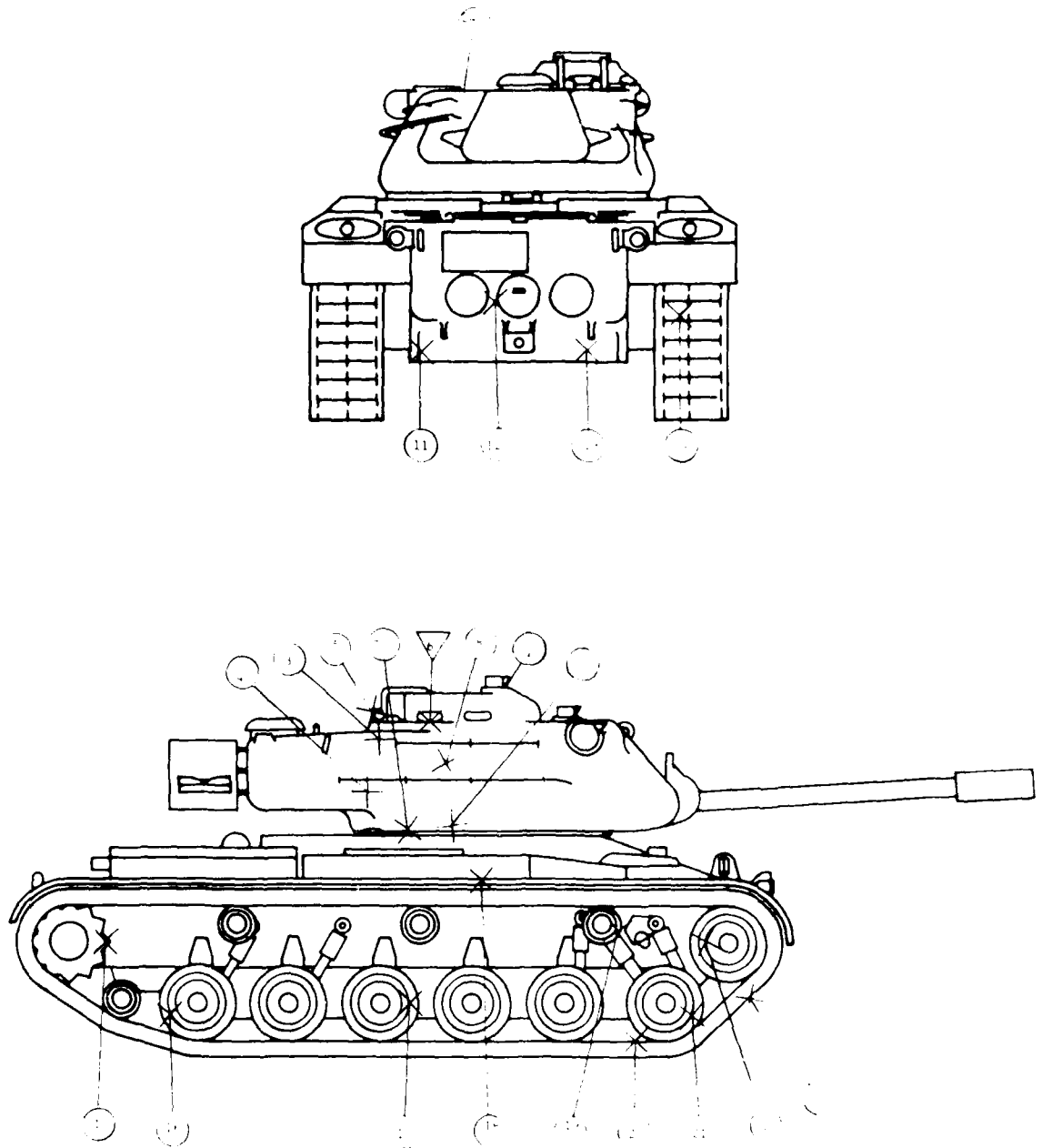

FIGURE 25. Impact Diagram, Target 21.



FIGURE 28. Target 6, target 21, penetration into Fighting Squadron through Vision Block in Commander's cupola.



FIGURE 29. Target 9, target 21, penetration into Fighting Squadron through Vision Block in Commander's cupola.



FIGURE 26. Impact Seven, Target 21, Showing Location of Strike which Jammed the Turret.

TARGET TANK NUMBER 22 DAMAGE SUMMARY

1. Description:

The attacking A-10 aircraft impacted target tank number 22 with 25 projectiles, fired from an aspect angle of 156 degrees (right rear) during one pass at low altitude and low dive angle, while expending 66 rounds.

2. Kill Assessment:

100% M-Kill, resulting from the following projectile impacts, shown in Figure 29:

a. Perforations : 0
b. Significant Impacts : 8
c. Insignificant Impacts: 17

Total Impacts : 25

3. Rationale for Kill Assessment:

The primary contributors to the kill were impacts 10 and 12, shown in Figures 30 and 31, respectively, which destroyed the right #4 roadwheel bearing spacer and hub, damaging the spindle; and impacts 6 and 25, shown in Figures 32 and 33, respectively, which severely damaged the right drive sprocket. Cumulative damage from four other impacts contributed to the kill.

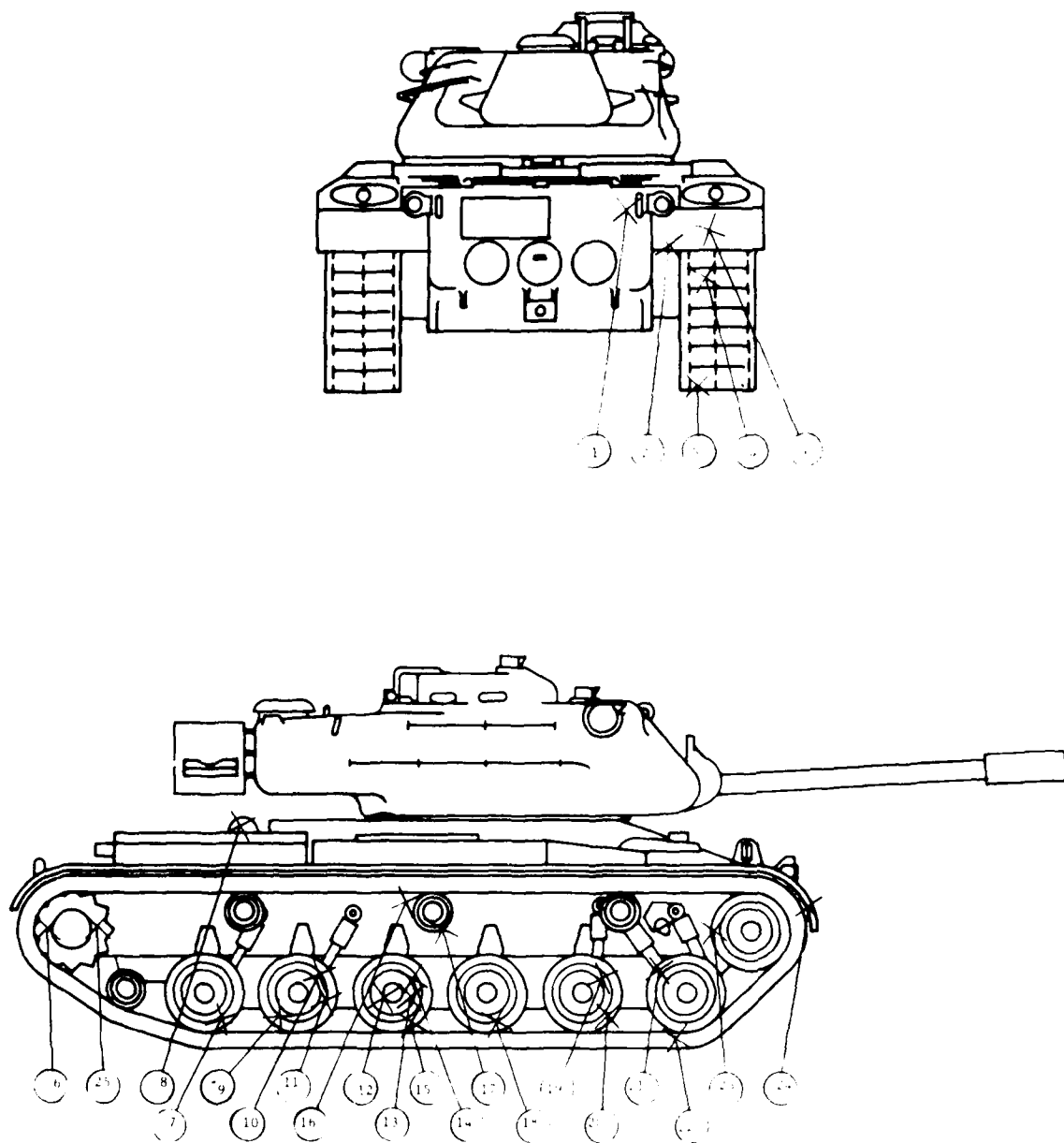

FIGURE 29. Impact Diagram, Target 22.



FIGURE 30. Impact Test, Target 22, which damaged the Right Number 14 roller, bent the Right Number 4 shaft and bearing spacer, and damaged the S. roller.

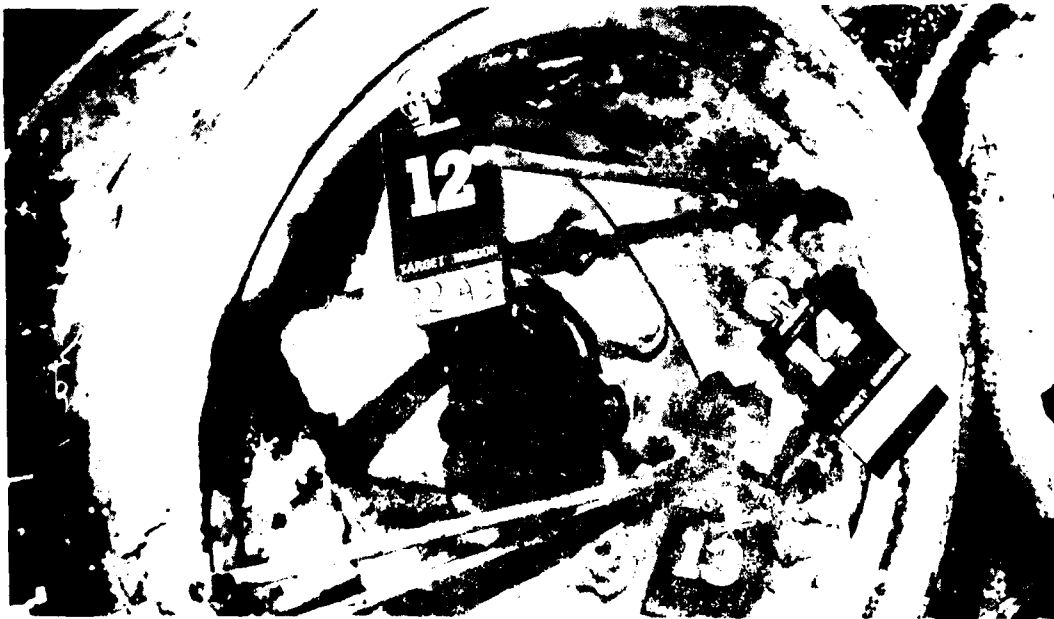

FIGURE 31. Impact Test, Target 22, which damaged the Right Number 14 roller, bent the Right Number 4 shaft and bearing spacer, and damaged the S. roller.

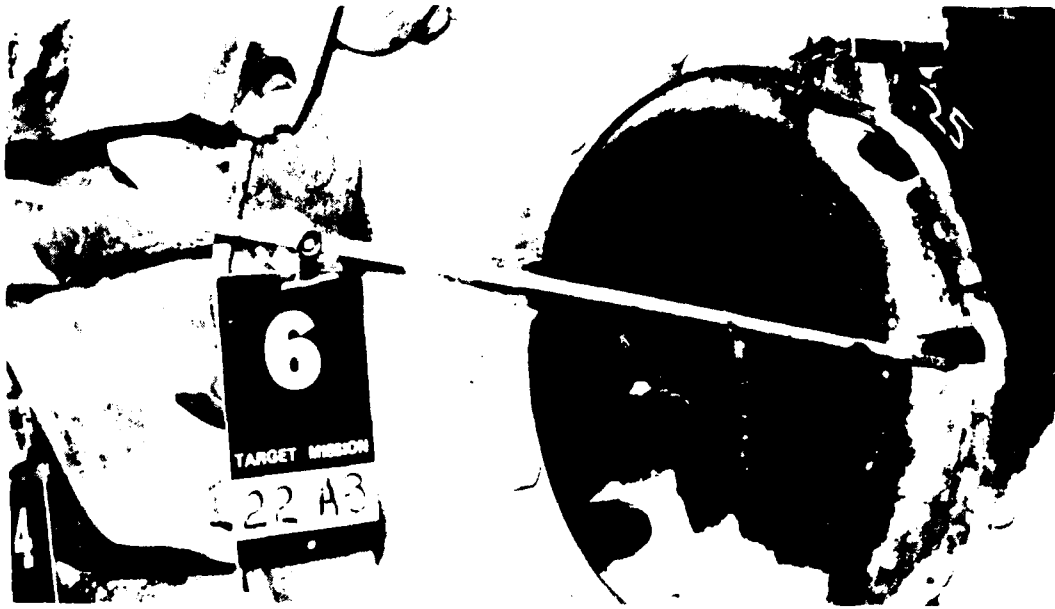

FIGURE 32. Target 218, target day, showing damage to front of target.



FIGURE 33. Target 218, target day, showing damage to front of target.

TARGET TANK NUMBER 23 DAMAGE SUMMARY

1. Description:

The attacking A-10 aircraft impacted target tank number 23 with 36 projectiles, fired from an aspect angle of 164 degrees (rear) during one pass at low altitude and low dive angle, while expending 107 rounds.

2. Kill Assessment:

100% M-Kill, resulting from the following projectile impacts, shown in Figure 34:

a. Perforations : 4
b. Significant Impacts : 14
c. Insignificant Impacts: 18

Total Impacts : 36

3. Rationale for Kill Assessment:

The target suffered four perforations. Three of the four perforations were capable of causing a 100% M-Kill.

Impact 16 (Figure 35) perforated the rear hull armor and penetrated the transmission thermostat and cross-over line. Impacts 18 and 21, shown in Figures 36 and 37, respectively, perforated the rear hull armor and penetrated the transmission case. One other perforation (Impact 13) had no behind-the-plate effects.

Both final drives were damaged sufficiently to cause an M-Kill. Impacts 10 and 11, shown in Figures 38 and 39, respectively, penetrated the left final drive. Impact 25 (Figure 40) penetrated the right final drive.

Cumulative damage to the track and suspension system from 11 other impacts (numbers 7, 8, 9, 28, 29, 30, 31, 32, 34, 35, and 36 contributed to the kill).

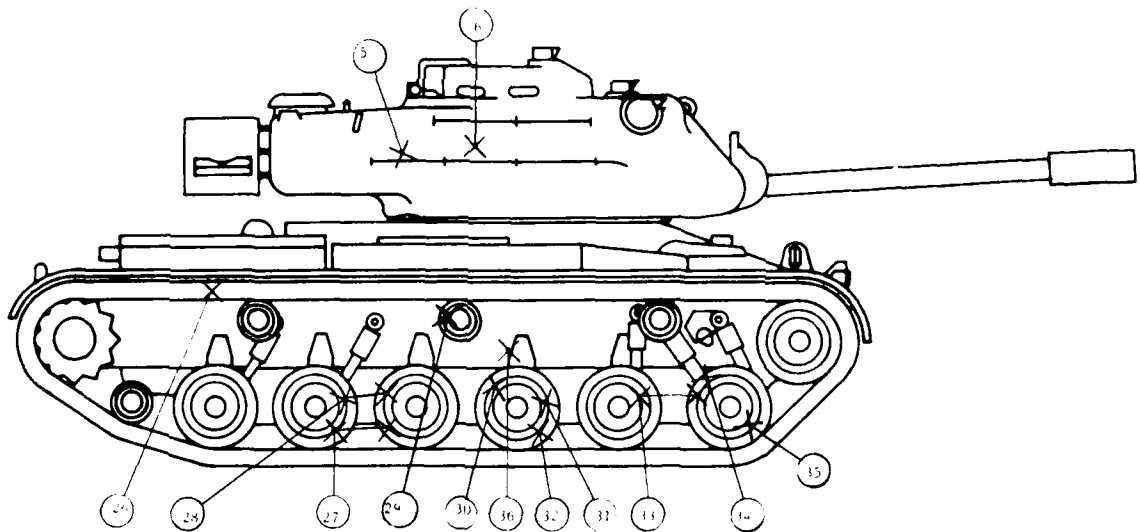
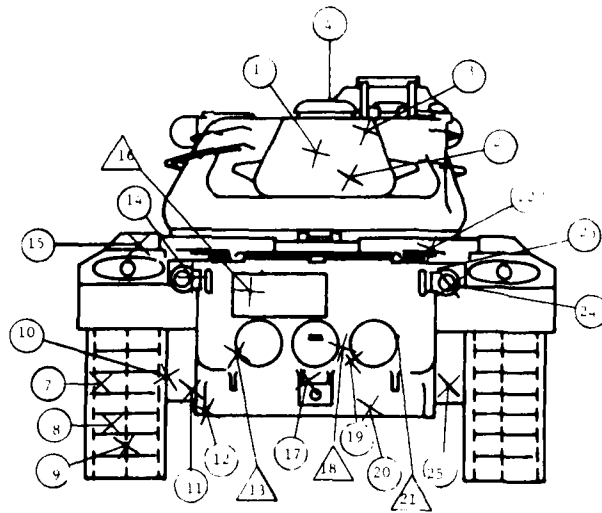

FIGURE 34. Impact Diagram, Target 23.

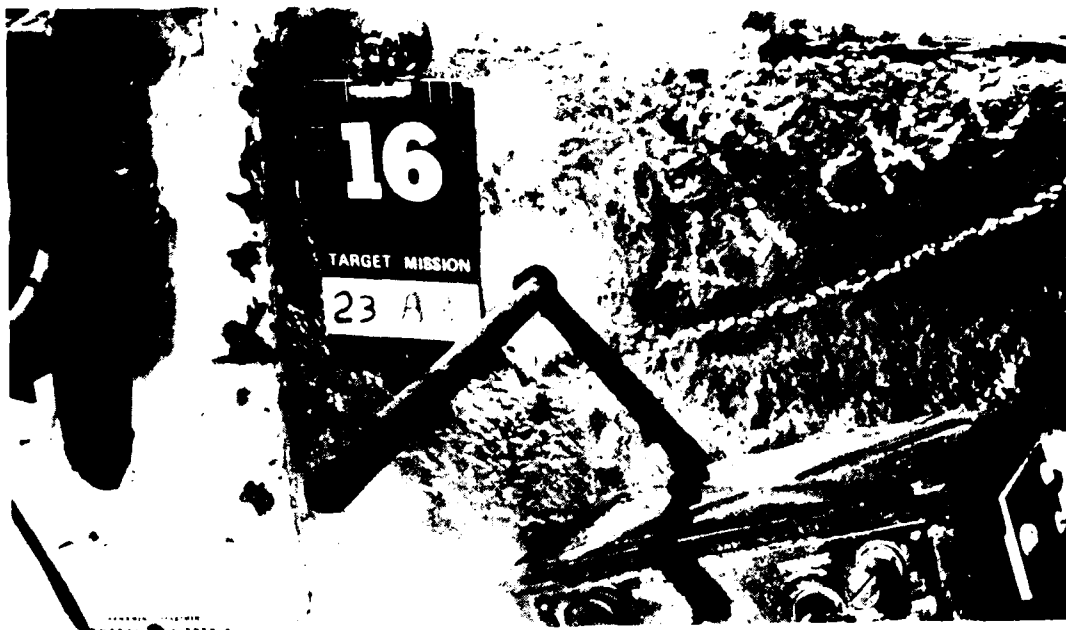

FIGURE 16. Close-up of target sign, identification of seat
 and other details of the transportation capability,
 and the location of the target sign in the target
 area.



FIGURE 18. Close-up of target sign, identification of seat
 and other details of the transportation capability,
 and the location of the target sign in the target
 area.



FIGURE 30. Target Twenty-One, Target 23, Perforation of rear window and Penetration into the Trans-



FIGURE 31. Target Twenty-One, Target 23, Penetration into the Left



1st Lt. Robert L. ...
... 1st Lt. ...



1st Lt. Robert L. ...
... 1st Lt. ...

TARGET TANK NUMBER 26 DAMAGE SUMMARY

1. Description:

The attacking A-10 aircraft impacted target tank number 26 with 16 projectiles, fired from an aspect angle of 166 degrees (rear) during one pass at low altitude and low dive angle, while expending 107 rounds.

2. Kill Assessment:

100% M-Kill, resulting from the following projectile impacts, shown in Figure 41:

a. Perforations	:	3
b. Significant Impacts	:	2
c. Insignificant Impacts:		<u>11</u>

Total Impacts	:	16
---------------	---	----

3. Rationale for Kill Assessment:

A 100% M-Kill was assessed because of Impacts 12 and 13, shown in Figures 42 and 43, respectively, which perforated the rear hull armor and penetrated the transmission case. Two other impacts (4 and 6), which caused slight damage to the track, made a minor contribution to the kill. One other hit (Impact 9) perforated the rear hull into the transmission compartment, but the extent of the damage could not be determined.

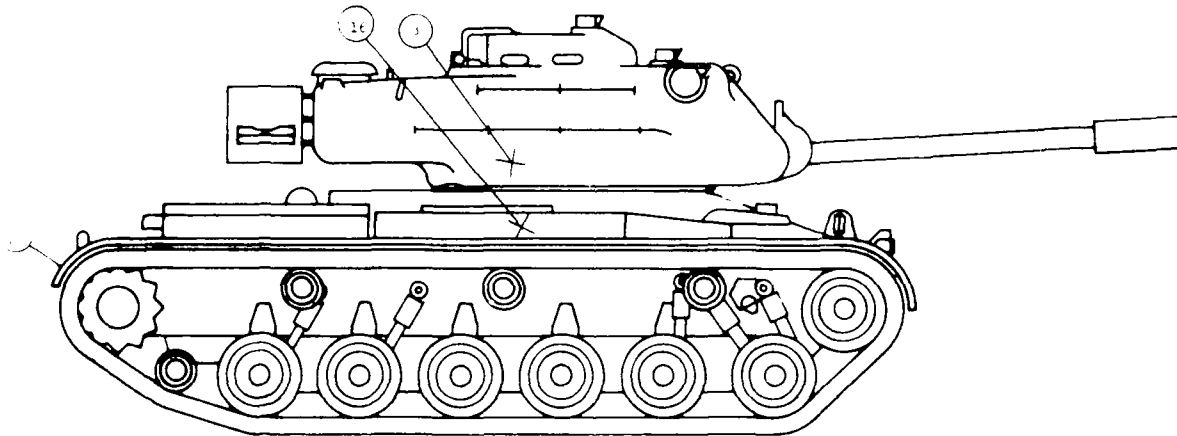
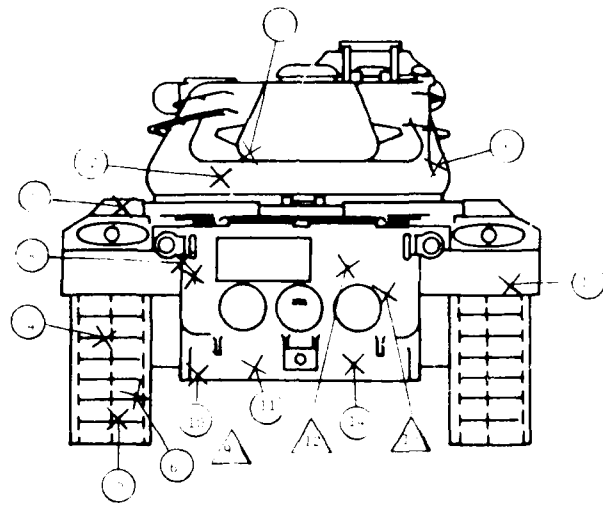

FIGURE 41. Impact Diagram, Target 26.



FIGURE 42. Impact location, target 12, Perforation of Rear Axle Housing and penetration into the Transmission Case.



FIGURE 43. Impact location, target 13, Perforation of Rear Axle Housing and penetration into the Transmission Case.

TARGET TANK NUMBER 27 DAMAGE SUMMARY

1. Description:

The attacking A-10 aircraft impacted target tank number 27 with 14 projectiles, fired from an aspect angle of 198 degrees (rear) during one pass at low altitude and low dive angle, while expending 85 rounds.

2. Kill Assessment:

10% M-Kill, resulting from the following projectile impacts, shown in Figure 44:

a. Perforations	:	0
b. Significant Impacts	:	5
c. Insignificant Impacts:		<u>9</u>
Total Impacts	:	14

3. Rationale for Kill Assessment:

A 10% M-Kill was assessed due to the impacts on the track and suspension system. Impact 6, shown in Figure 45, is representative of the most severe damage inflicted during this attack.

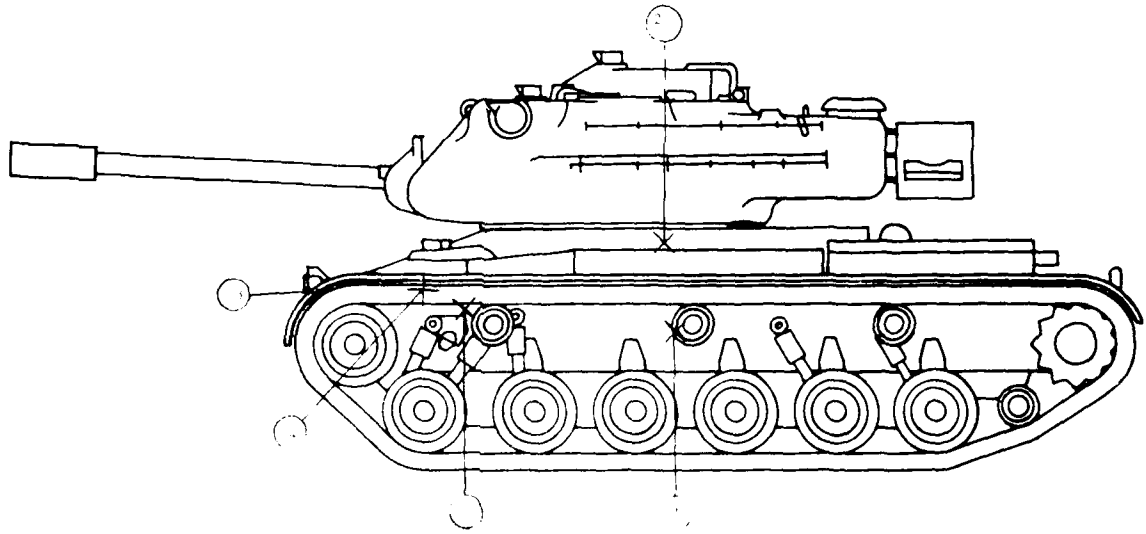
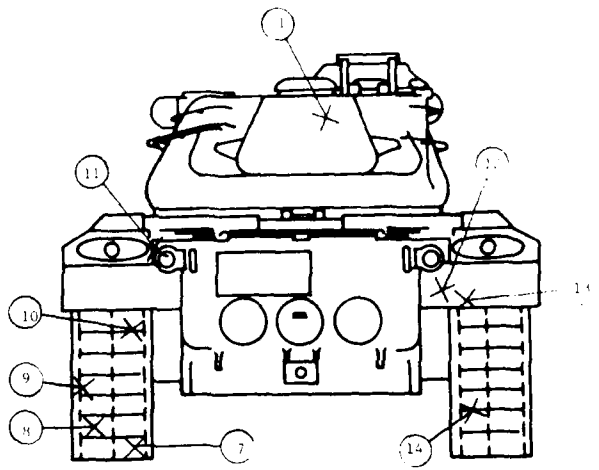

FIGURE 44. Impact Diagram, Target 27.

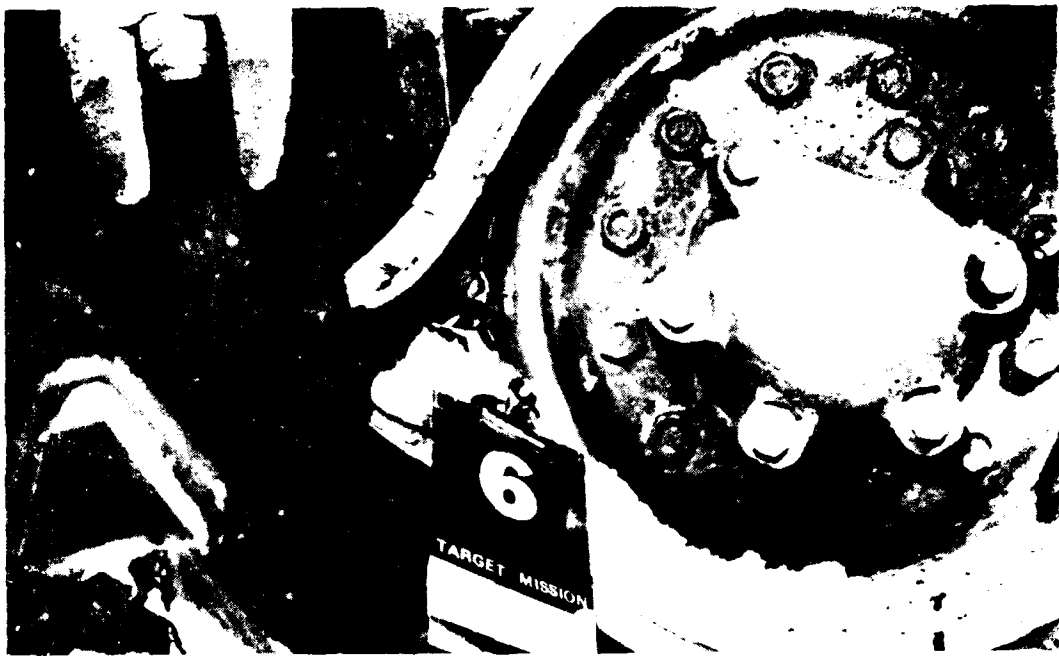

FIGURE 45. Impact Six, Target 27, Showing Damage to Left Number 2 Track Support Roller.

TARGET TANK NUMBER 28 DAMAGE SUMMARY

1. Description:

The attacking A-10 aircraft impacted target tank number 28 with 53 projectiles, fired from an aspect angle of 237 degrees (rear) during one pass at low altitude and low dive angle, while expending 79 rounds.

2. Kill Assessment:

100% M-Kill and 95% F-Kill, resulting from the following projectile impacts, shown in Figure 46:

a. Perforations	:	9
b. Significant Impacts	:	12
c. Insignificant Impacts:		<u>32</u>

Total Impacts	:	53
---------------	---	----

3. Rationale for Kill Assessment:

- a. M-Kill: A 100% M-Kill was assessed because of Impact 38 (Figure 47) which perforated the left hull and penetrated the left fuel tank, and to Impacts 34 and 44, shown in Figures 48 and 49, respectively, which destroyed the left #5 and #6 roadwheel hubs. Cumulative damage to the track and suspension system from 10 other impacts contributed to the M-Kill.
- b. F-Kill: A 95% F-Kill was assessed because of casualties caused to all crewmen in the fighting compartment by eight perforations of the hull and turret armor. One additional perforation had no behind-the-plate effects.

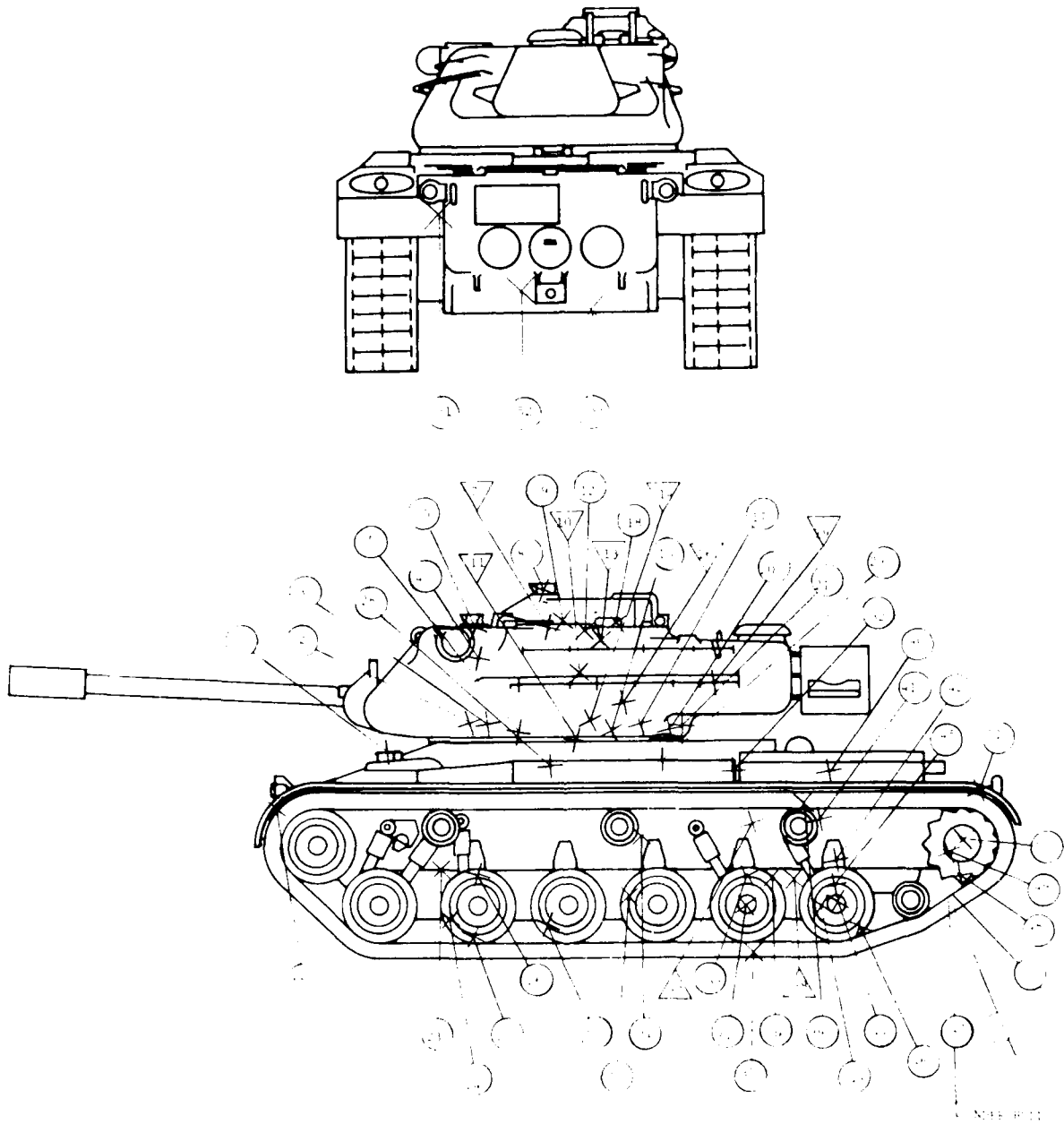

FIGURE 46. Impact Diagram, Target 28.



FIGURE 47. Impact Thirty-Eight, Target 28, Perforation of Hull Armor and Penetration into Left Fuel Tank.



FIGURE 48. Impact Thirty-Eight, Target 28, Penetration of the Left Fuel Tank, which Destroyed the Fuel Tank.



FIGURE 49. Impact Forty-Four, Target 28, which Destroyed the Left Number Six Roadwheel Hub.

TARGET TANK NUMBER 29 DAMAGE SUMMARY

1. Description:

The attacking A-10 aircraft impacted target tank number 29 with 39 projectiles, fired from an aspect angle of 215 degrees (left rear) during one firing pass at low altitude and low dive angle, while expending 73 rounds.

2. Kill Assessment:

100% M-Kill, resulting from the following projectile impacts, shown in Figure 50:

a. Perforations : 3
b. Significant Impacts : 14
c. Insignificant Impacts: 22

Total Impacts : 39

3. Rationale for Kill Assessment:

There were three perforations into the transmission compartment, one of which (Impact 37) had no behind-the-plate effects. Either of the other two perforations was capable of causing an M-Kill. Impact 34 (Figure 51) perforated the left hull armor and severed the steering control rod. Impact 36 (Figure 52) perforated the rear hull armor and penetrated the transmission case. Cumulative damage to the track and suspension system from 14 other impacts contributed to the kill.

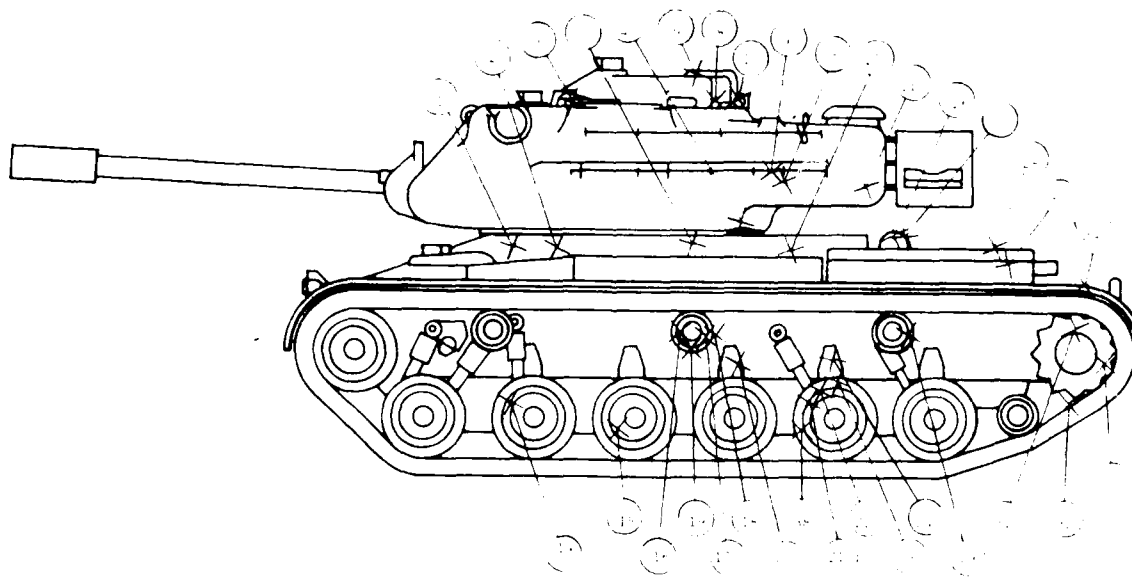
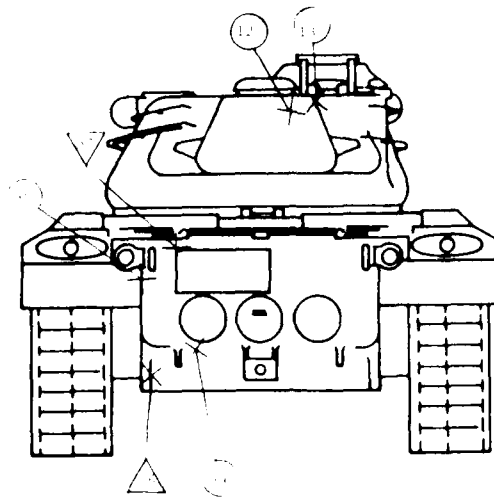

FIGURE 50. Impact Diagram, Target 29.



FIG. 1. (a) ... (b) ... Perforation of ... which covered the steering



FIG. 2. (a) ... (b) ...

TARGET TANK NUMBER 30 DAMAGE SUMMARY

1. Description:

The attacking A-10 aircraft impacted target tank number 30 with 50 projectiles, fired from an aspect angle of 228 degrees (left rear) during one pass at low altitude and low dive angle, while expending 83 rounds.

2. Kill Assessment:

100% M-Kill and 100% F-Kill, resulting from the following projectile impacts, shown in Figure 53:

- a. Perforations : 7
- b. Significant Impacts : 10
- c. Insignificant Impacts: 33

Total Impacts : 50

3. Rationale for Kill Assessment:

- a. M-Kill: This target suffered three perforations of the hull and one other impact which were capable of causing an M-Kill. Impact 30 (Figure 54) perforated the left hull armor and penetrated the left fuel tank. Impact 34, shown in Figures 55 and 56, respectively, perforated the left hull armor and penetrated an oil cooler line. Impact 36 (Figure 58) perforated the rear hull armor and penetrated the transmission case. Impact 47 (Figure 58) penetrated the right final drive. Two other perforations (Impacts 35 and 39) into the engine compartment had no behind-the-plate effects. Cumulative damage to the track and suspension system from seven other impacts contributed to the kill (these included a possible perforation of the left hull armor and penetration into the left fuel tank).
- b. F-Kill: Impact 3 jammed the turret so that it could not be traversed. Impact 8 perforated the tank commander cupola and caused casualties to the tank commander and gunner. Two other impacts contributed to the kill by penetrating one wall of the gun tube, possibly jamming the turret.

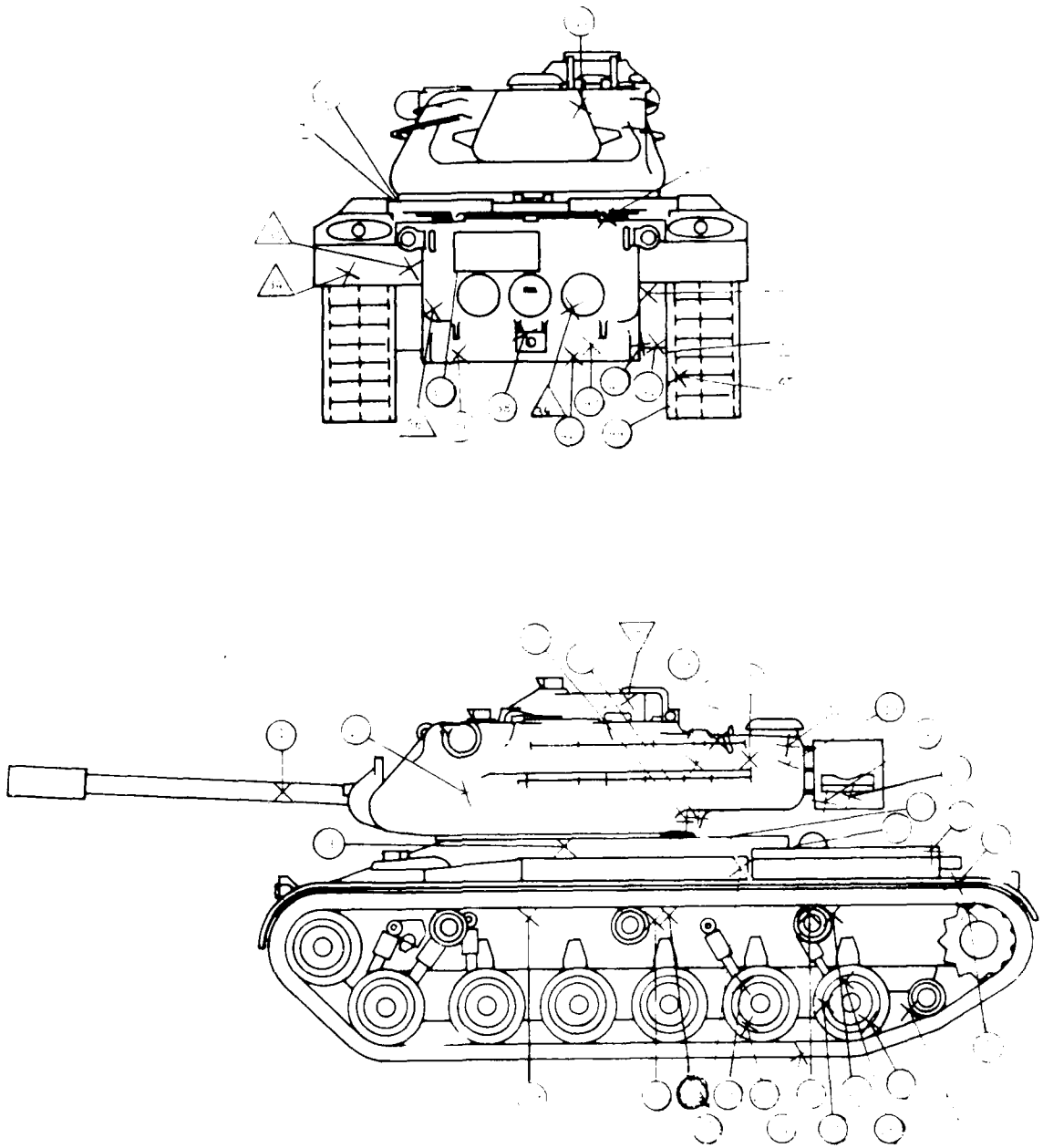

FIGURE 53. Impact Diagram, Target 30.



FIGURE 54. Impact Entry, Target 30, Perforation of Bottom Hull Air Seal and Penetration into Left Fuel Tank. (Initial Impact was on Left Track Tension Idler Wheel and Left Wheel (6) (Forward))



FIGURE 55. Impact Entry, Target 30, Perforation of Bottom Hull Air Seal and Penetration into Left Fuel Tank.



FIGURE 56. Impact Thirty-Four, Target 30, Caused Penetration of Transmission Oil Cooler Line Behind Armor.



FIGURE 57. Impact Thirty-Five, Target 30, Perforation of Tank and Penetration into the Tank.



FIGURE 58. Impact Forty-Seven, Target 30, Penetration into the Right Final Drive.

TARGET TANK NUMBER 31 DAMAGE SUMMARY

1. Description:

The attacking A-10 aircraft impacted target tank number 31 with 50 projectiles, fired from an aspect angle of 228 degrees (left rear) during one pass at low altitude and low dive angle, while expending 82 rounds.

2. Kill Assessment:

100% M-Kill and 100% F-Kill resulting from the following projectile impacts, shown in Figure 59:

a. Perforations	:	12
b. Significant Impacts	:	11
c. Insignificant Impacts:		<u>27</u>
Total Impacts		: 50

3. Rationale for Kill Assessment:

- a. M-Kill: This target suffered three perforations which alone or together were capable of causing an M-Kill. Impacts 21 and 30, shown in Figures 60 and 61, respectively, perforated the left hull and penetrated the left fuel tank. Impact 33 (Figure 61) perforated the left hull into the engine compartment and penetrated the oil cooler space; if the cooler had been in place it would have been damaged or destroyed. One other perforation into the engine compartment had no behind-the-plate effects. Cumulative damage to the track and suspension system from 10 other impacts contributed to the kill.
- b. F-Kill: The F-Kill resulted from crew casualties attributed to eight perforations (Impacts 3, 5, 6, 7, 8, 10, 11, and 13) through the fighting compartment and from impact 14, which jammed the turret, preventing it from traversing. Two rounds of ammunition in the ready rack were impacted by projectile, spall or a large debris fragment from one or more of the perforations (most likely Impacts 3, 6, or 7). The damage to the warhead of round 7 in the ready rack was probably severe enough to detonate it causing a K-Kill if the projectile had been filled with high explosive. (A mix of kinetic and chemical energy rounds is normally carried in the ready rack. The warhead of the round impacted was inert and reacted as an AP warhead. With a hit on the warhead of an AP rounds there would not have been a K-Kill).

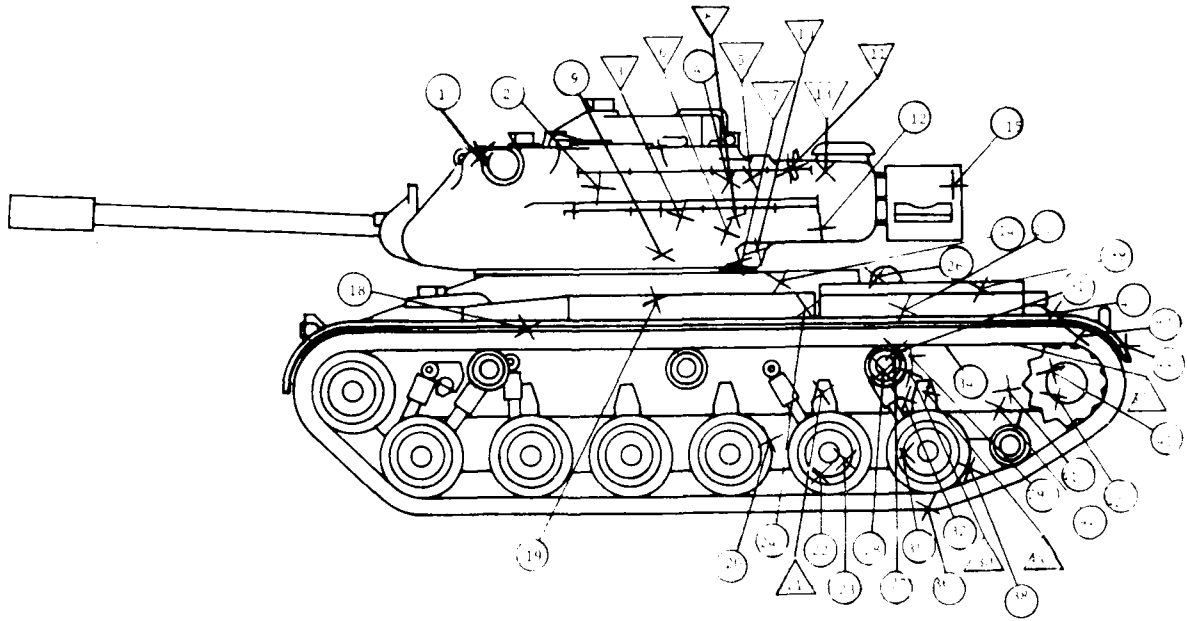
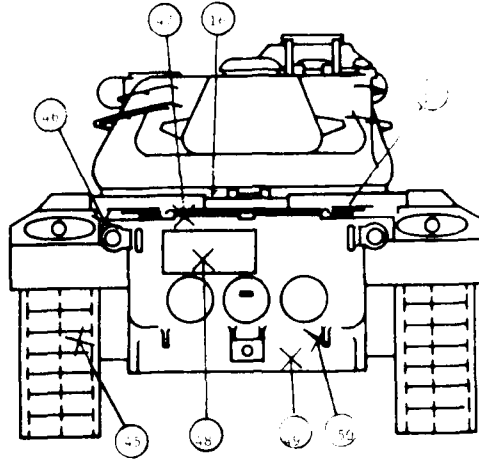

FIGURE 59. Impact Diagram, Target 31.



Figure 1. A person in a dark, confined space, possibly a tunnel or cave, wearing a light-colored, rectangular object on their back. The person is looking towards the camera.



Figure 2. A person in a dark, confined space, possibly a tunnel or cave, wearing a light-colored, rectangular object on their back. The person is looking towards the camera. The number '30' is visible on the left side of the image, and the number '33' is visible on the right side of the image.

TARGET TANK NUMBER 32 DAMAGE SUMMARY

1. Description:

The attacking A-10 aircraft impacted target tank number 32 with 18 projectiles, fired from an aspect angle of 237 degrees (left rear) during one pass at low altitude and low dive angle, while expending 129 rounds.

2. Kill Assessment:

100% K-Kill, resulting from the following projectile impacts, shown in Figure 62:

a. Perforations	:	5
b. Significant Impacts	:	**
c. Insignificant Impacts:		<u>**</u>

Total Impacts : 18

**Omitted - Catastrophic fire and explosion overrode other damages.

3. Rationale for the fire Kill Assessment

Tank 32 was observed to be burning immediately after the attack; the fire probably was caused by Impact 17 (Figure 63) which perforated the left hull and penetrated the left fuel tank. The tank suffered three other perforations (Impacts 4, 5, and 10), which probably caused casualties to the tank commander, gunner, loader and driver. One other perforation (Impact 18) perforated the rear hull armor and penetrated the transmission case, but made no apparent contribution to the catastrophic kill. In the judgement of the Combat Damage Assessment Team, the simultaneous outbreak of a major fire and occurrence of four casualties would have prevented the crew from effectively controlling the fire.

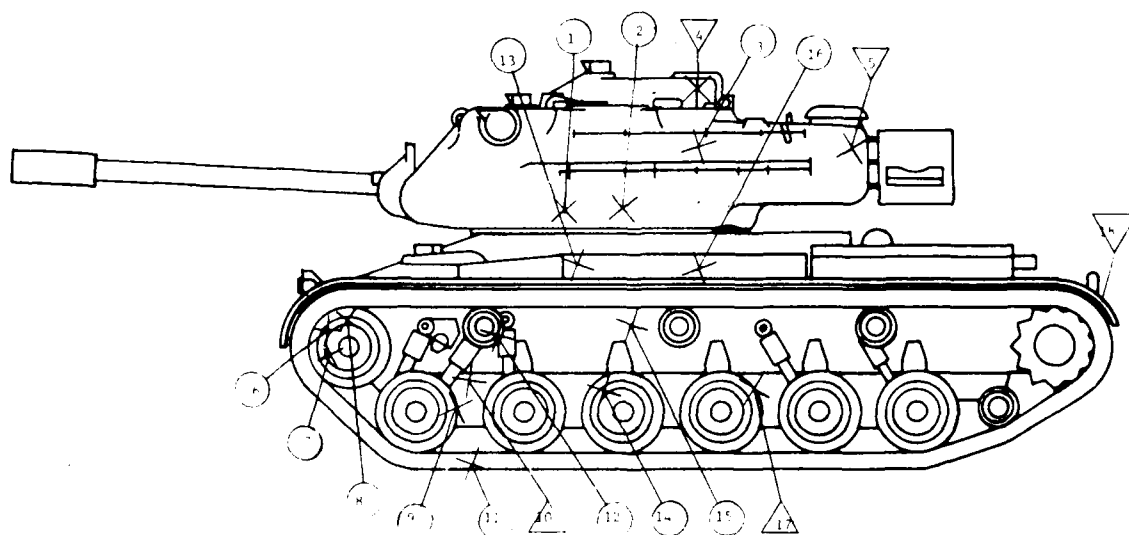

FIGURE 62. Impact Diagram, Target 32.



FIGURE 63. Impact Seventeen, Target 32, Perforation of the hull Armor and Penetration into the Left Fuel Tank.

TARGET TANK NUMBER 33 DAMAGE SUMMARY

1. Description:

The attacking A-10 aircraft impacted target tank number 33 with 33 projectiles, fired from an aspect angle of 232 degrees (left rear) during one pass at low altitude and low dive angle, while expending 82 rounds.

2. Kill Assessment:

100% M-Kill and 95% F-Kill resulting from the following projectile impacts, shown in Figure 64:

a. Perforations	:	4
b. Significant Impacts	:	5
c. Insignificant Impacts:		<u>24</u>
Total Impacts	:	33

3. Rationale for Kill Assessment:

- a. M-Kill: This target suffered 4 perforations, two of which were independently capable of causing an M-Kill. Impact 24 perforated the left hull and severed an oil cooler line. Impact 26, shown in Figure 65 and 66, respectively, perforated the rear brake adjust access door and penetrated the transmission case. Cumulative damage to the track and suspension system from 5 other impacts contributed to the kill.
- b. F-Kill: A 95% F-Kill was assessed based solely on crew casualties (tank commander and gunner - Figures 67 and 68) resulting from Impacts 6 and 8 which perforated the left side of the turret.

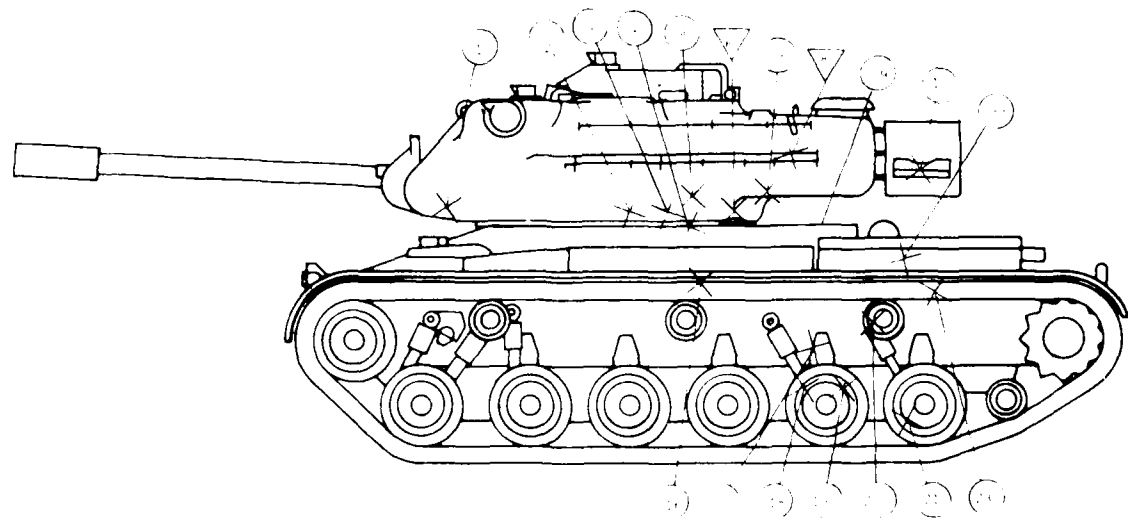
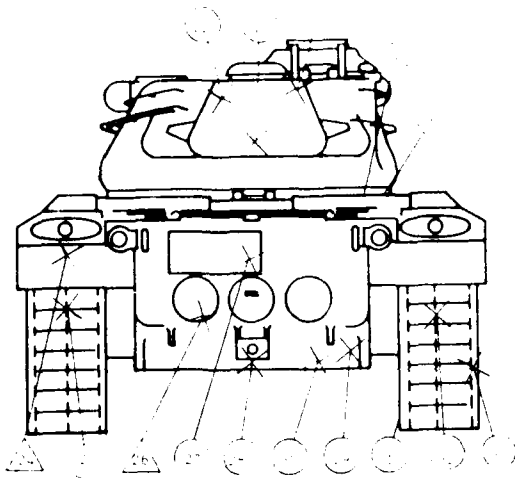

FIGURE 64. Impact Diagram, Target 33.



FIGURE 1. (a) Photograph of the lens of the microscope used in the experiment.



FIGURE 2. (b) Photograph of the lens of the microscope used in the experiment.



Figure 1. Shell casing showing impact marks and the text '33 A3' on the casing.

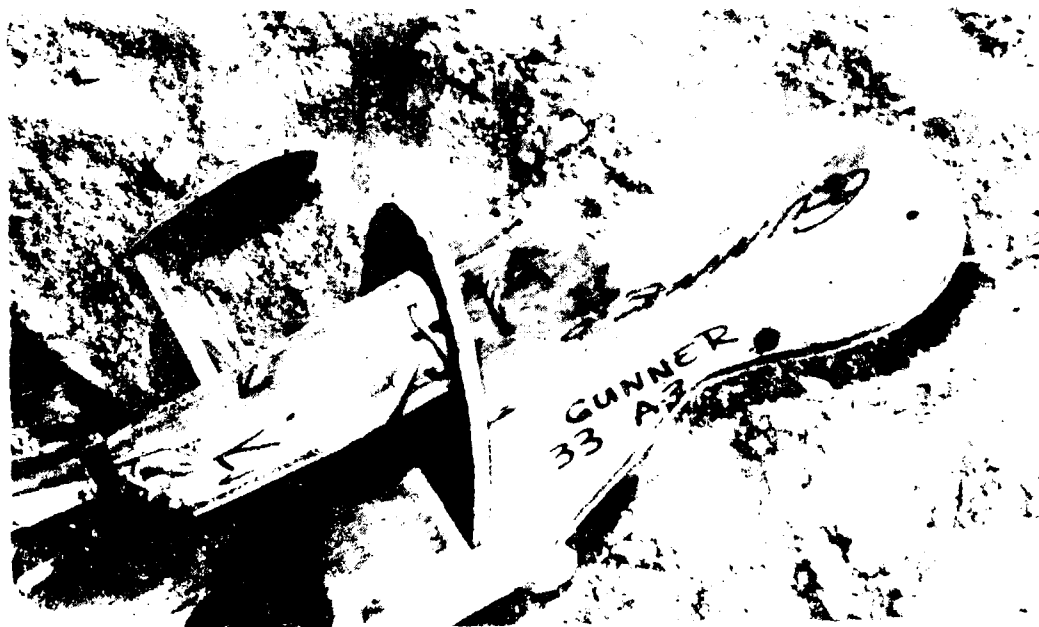

TARGET TANK NUMBER 34 DAMAGE SUMMARY

1. Description:

The attacking A-10 aircraft impacted target tank number 4 with 16 projectiles, fired from an aspect angle of 246 degrees (left side) during one pass at low altitude and low dive angle, while expending 92 rounds.

2. Kill Assessment:

100% F-Kill, resulting from the following projectile impacts, shown in Figure 69:

a. Perforations	:	1
b. Significant Impacts	:	1
c. Insignificant Impacts:		<u>14</u>

Total Impacts	:	16
---------------	---	----

3. Rationale for Kill Assessment:

Impact 2 (Figure 70) hit between the turret and hull, bulging the armor on the inside, and jammed the turret so that it would not traverse. The perforation, shown in Figure 71, Impact 7, penetrated into the bulkhead ammunition stowage rack and into the adjacent stowage box, but did not impact any of the stowed ammunition.

AD-A095 736

NAVAL POSTGRADUATE SCHOOL MONTEREY CA F/G 19/4
A-10/GAU-8 LOW ANGLE FIRINGS VERSUS SIMULATED SOVIET TANK BATTAL--ETC(U)
AUG 80 R H STOLFI, R R MCEACHIN
NPS-56-81-001

UNCLASSIFIED

NL

2 of 2

AD-A095 736

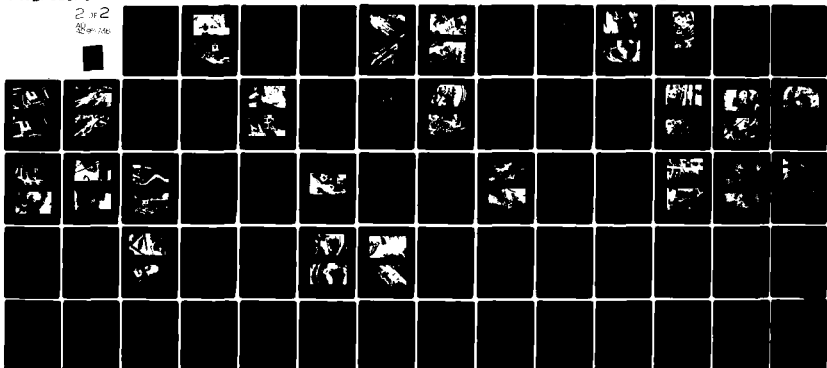

END
DATE
FILMED
3-81
DTIC

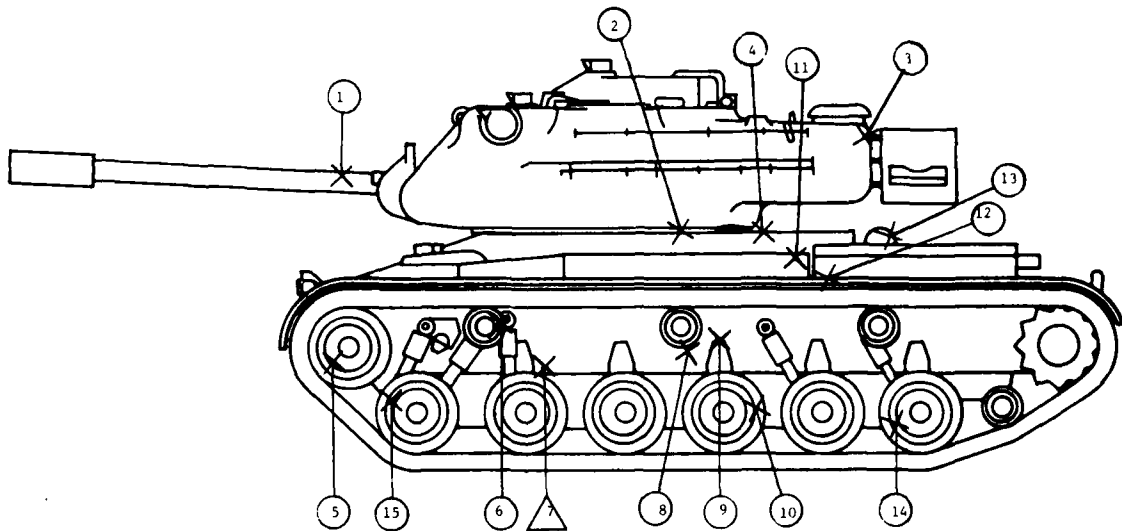

NOTE: Roadwheels number 4 and 5 were hit on the right hand side of the tank (Impact number 16), and are not shown in this view.

FIGURE 69. Impact Diagram, Target 34.



FIGURE 70. Impact Two, Target 34, Penetration of Turret Ring between Hull and Turret, Armor Bulged, Turret Jammed.

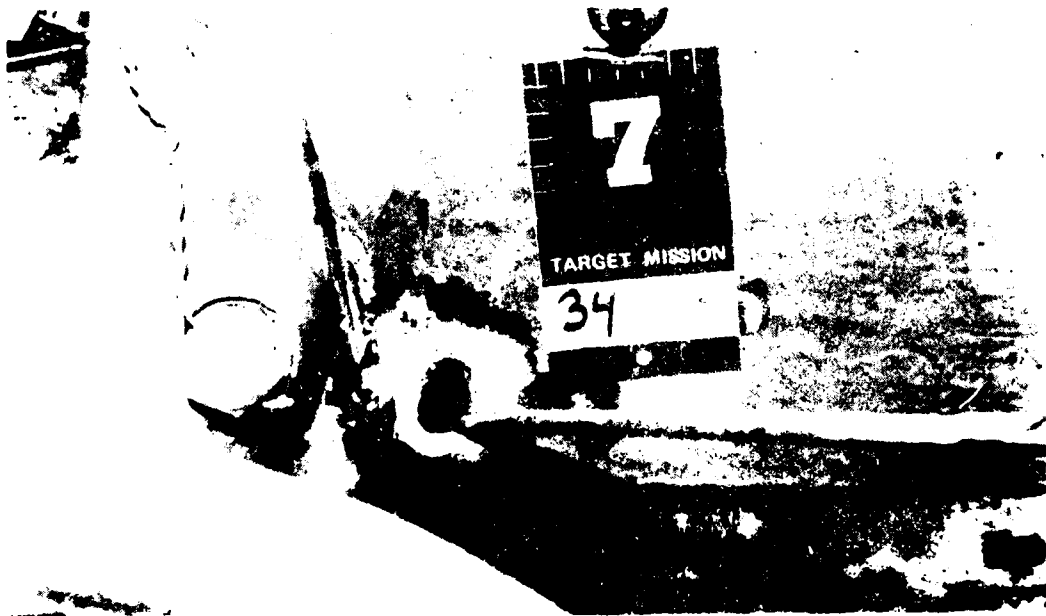

FIGURE 71. Impact Seven, Target 34, Penetration of the Left Hull Armor in the Stowage Area.

1

TARGET TANK NUMBER 35 DAMAGE SUMMARY

1. Description:

The attacking A-10 aircraft impacted target tank number 35 with 51 projectiles, fired from an aspect angle of 232 degrees (left side) during one pass at low altitude and low dive angle, while expending 75 rounds.

2. Kill Assessment:

100% M-Kill and 100% F-Kill, resulting from the following projectile impacts, shown in Figure 72:

a. Perforations : 8
b. Significant Impacts : 12
c. Insignificant Impacts: 31

Total Impacts : 51

3. Rationale for Kill Assessment:

a. M-Kill: 100% M-Kill was due to crew casualties, shown in Figures 73, 74, and 75. It was caused by perforations into the fighting compartment from Impacts 2, 3, 6, 7, 8, and 10, and by cumulative damage to the track and suspension system from twelve other impacts. One other perforation (Impact 37) into the transmission compartment had no behind-the-plate effects.

b. F-Kill: 100% F-Kill was due to crew casualties, and to Impact 9 (Figure 76) which perforated the top hull and jammed the turret so that it would not traverse.

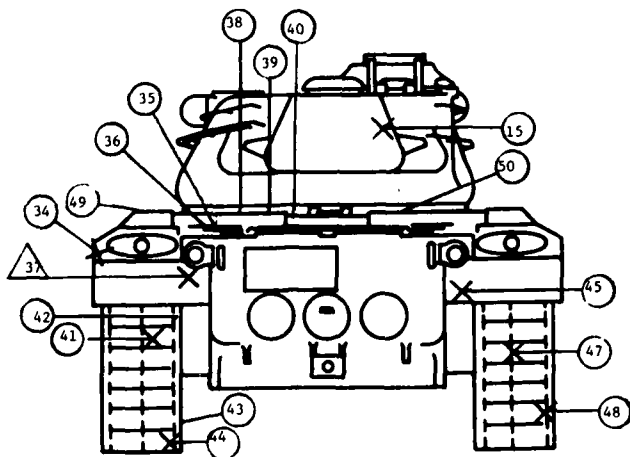

IMPACTS 38, 39 and 40 ON EXTENDED FUEL TANK BRACKET

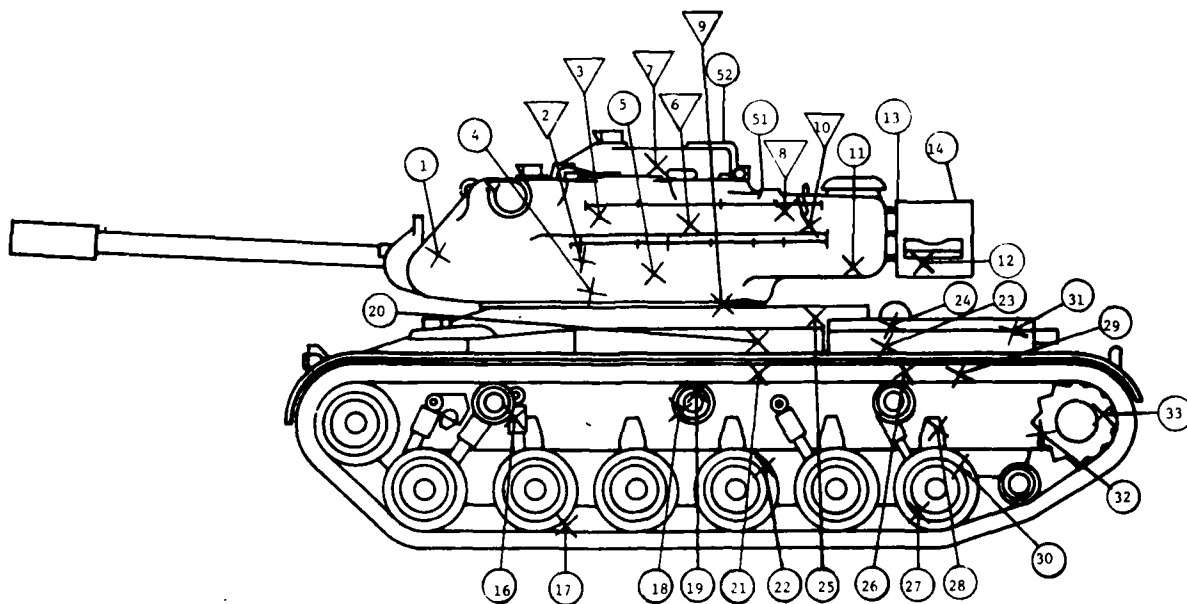

NOTE: The number 46 was not used in identifying hits.

FIGURE 72. Impact Diagram, Target 35.



FIGURE 73. Commander Manikin, Target 35, Showing Damage from Perforations into the Fighting Compartment.



FIGURE 74. Gunner Manikin, Target 35 Showing Damage from Perforations into the Fighting Compartment.

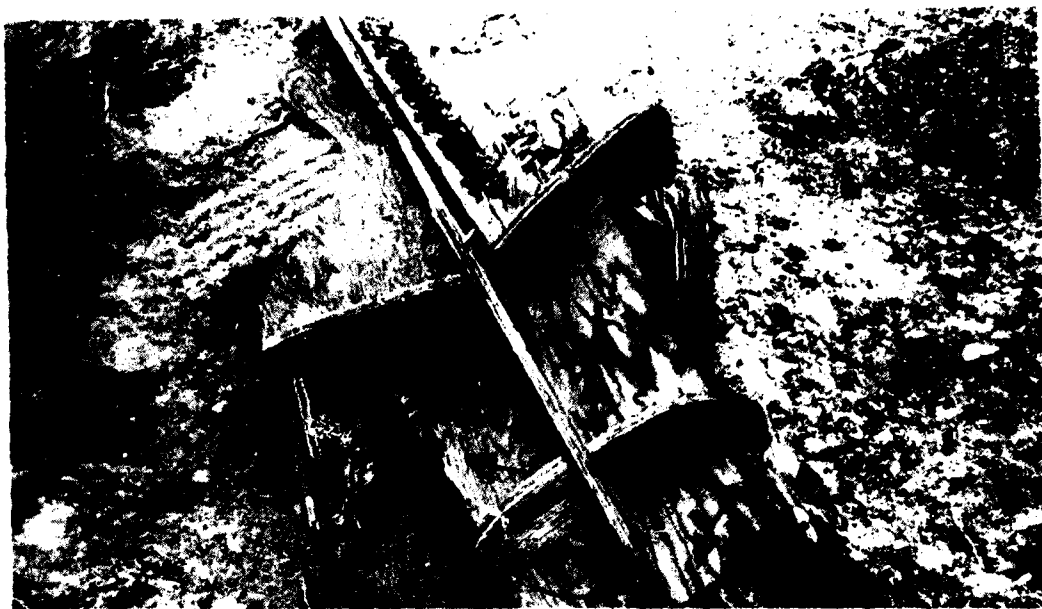

FIGURE 75. Loader Manikin, Target 35, Showing Damage from Perforations into the Fighting Compartment.



FIGURE 76. Impact Area, Target 35, with Perforation of Top of Loader which did not penetrate.

TARGET TANK NUMBER 36 DAMAGE SUMMARY

1. Description:

The attacking A-10 aircraft impacted target tank number 36 with 50 projectiles, fired from an aspect angle of 333 degrees (left front) during one pass at low altitude and low dive angle, while expending 97 rounds.

2. Kill Assessment:

100% M-Kill, resulting from the following projectile impacts, shown in Figure 77:

a. Perforations	:	0
b. Significant Impacts	:	25
c. Insignificant Impacts:		<u>25</u>

Total Impacts : 50

3. Rationale for Kill Assessment:

Major damage to the track and suspension system was caused by Impact 30 (Figure 78), which destroyed the left #2 roadwheel hub and bearings; Impact 31 (Figure 79), which destroyed the left #1 track support roller hub; and Impact 47 (Figure 80), which destroyed the left #5 roadwheel hub and bearings; and by twenty-two other impacts, which inflicted a high level of cumulative damage to the track and suspension system.

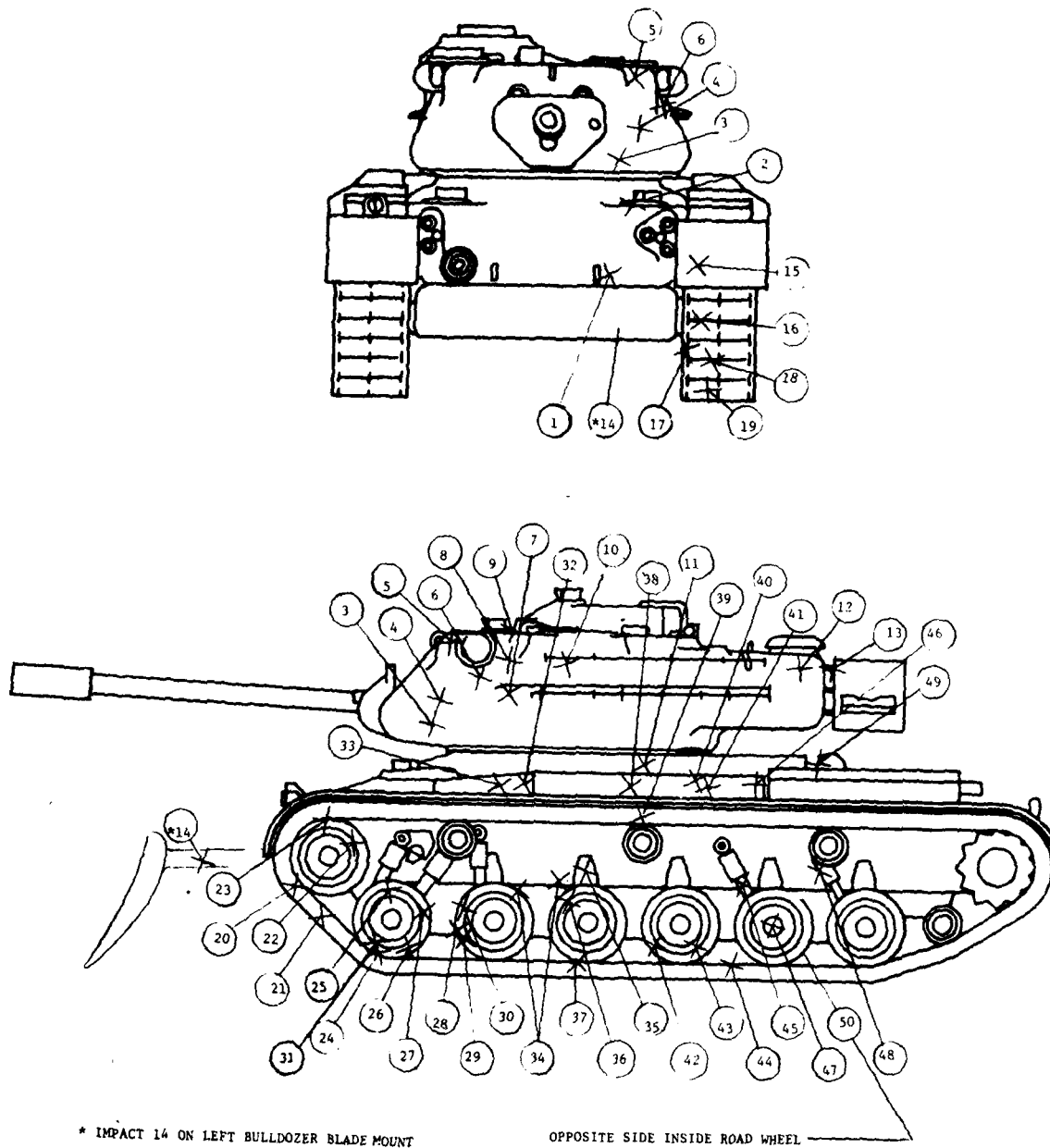

* IMPACT 14 ON LEFT BULLDOZER BLADE MOUNT

OPPOSITE SIDE INSIDE ROAD WHEEL

FIGURE 77. Impact Diagram, Target 36.



FIGURE 78. Impact Thirty, Target 36, which Destroyed the Left #2 Roadwheel Hub.

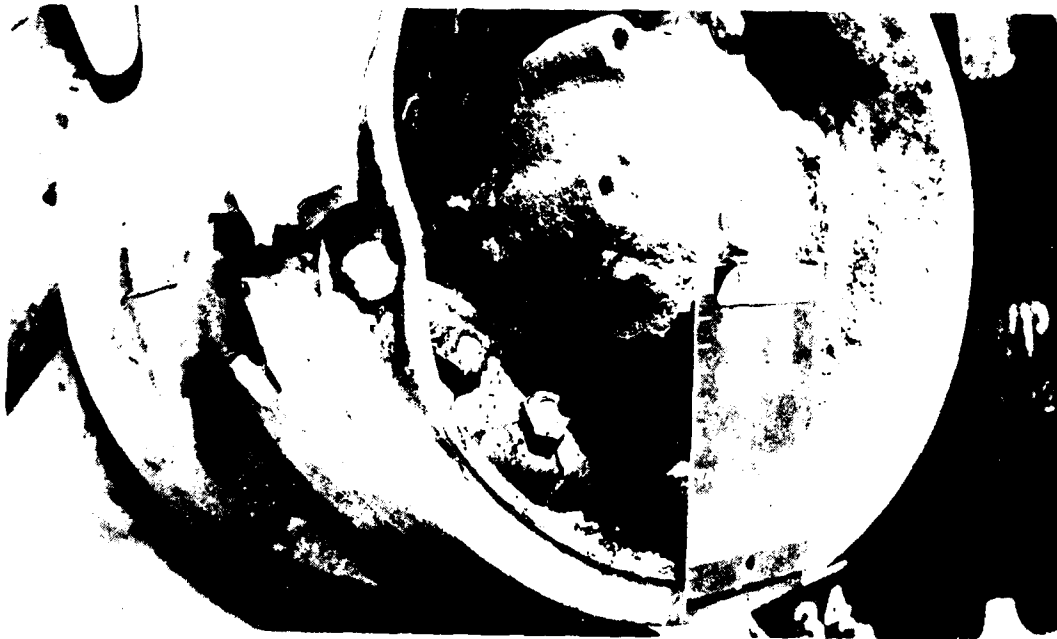

FIGURE 79. Impact Thirty-One, Target 36, which Damaged the Rim and Destroyed the Hub of the Left #1 Track Support Roller.



FIGURE 80. Impact Forty-seven, Target 36, which Destroyed the Left #5 Roadwheel Hub Bearings.

TARGET TANK NUMBER 37 DAMAGE SUMMARY

1. Description:

The attacking A-10 aircraft impacted target tank number 37 with 43 projectiles, fired from an aspect angle of 325 degrees (left front) during one pass at low altitude and low dive angle, while expending 72 rounds.

2. Kill Assessment:

80% M-Kill and 100% F-Kill resulting from the following projectile impacts, shown in Figure 81:

a. Perforations	:	4
b. Significant Impacts	:	15
c. Insignificant Impacts:		<u>24</u>
Total Impacts	:	43

3. Rationale for Kill Assessment:

- a. M-Kill: Mobility was estimated to have been degraded 80% by crew casualties and cumulative damage to the track and suspension system. The crew casualties resulted from impacts 9 and 19, and the cumulative track and suspension damage from 13 other impacts including 27, 29, 20, 31, 32, 33, 34, 35, 36, 37, 38, 39, and 40.
- b. F-Kill: A 100% F-Kill was assessed because of Impact 8, (Figure 82), which perforated the turret ring and jammed the turret; Impact 9 (Figure 83), which perforated the turret ring, jammed the turret, ignited propellant in an ammunition round in the ready rack, and wounded two crewmen (gunner and loader - Figures 84 and 85) and Impact 19, which perforated the lip of the loaders hatch, contributing to the loader casualty. One other perforation (Impact 23) of the antenna base aperture made no contribution to the kill. Two additional hits (Impacts 5 and 12) in the turret ring may have contributed to the jammed turret.

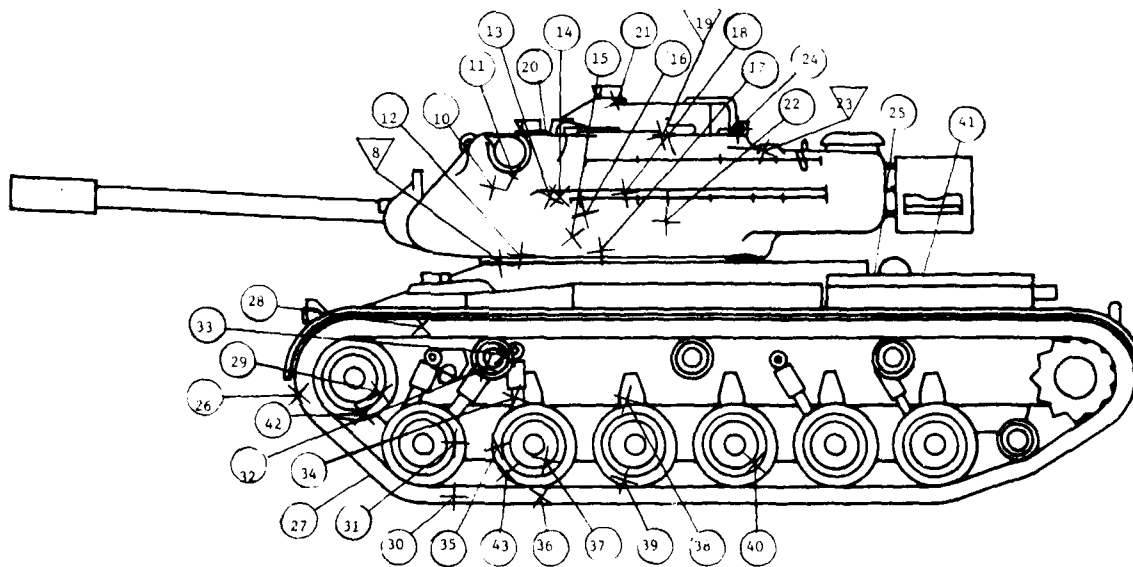
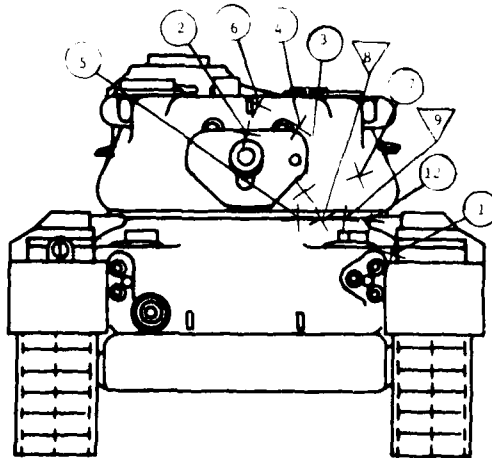

FIGURE 81. Impact Diagram, Target 37.



FIGURE 82. Impact Eight, Target 37, Perforations of Turret Ring which Jammed Turret.



FIGURE 83. Impact Nine, Target 37, Perforations of Turret Ring which Jammed Turret.

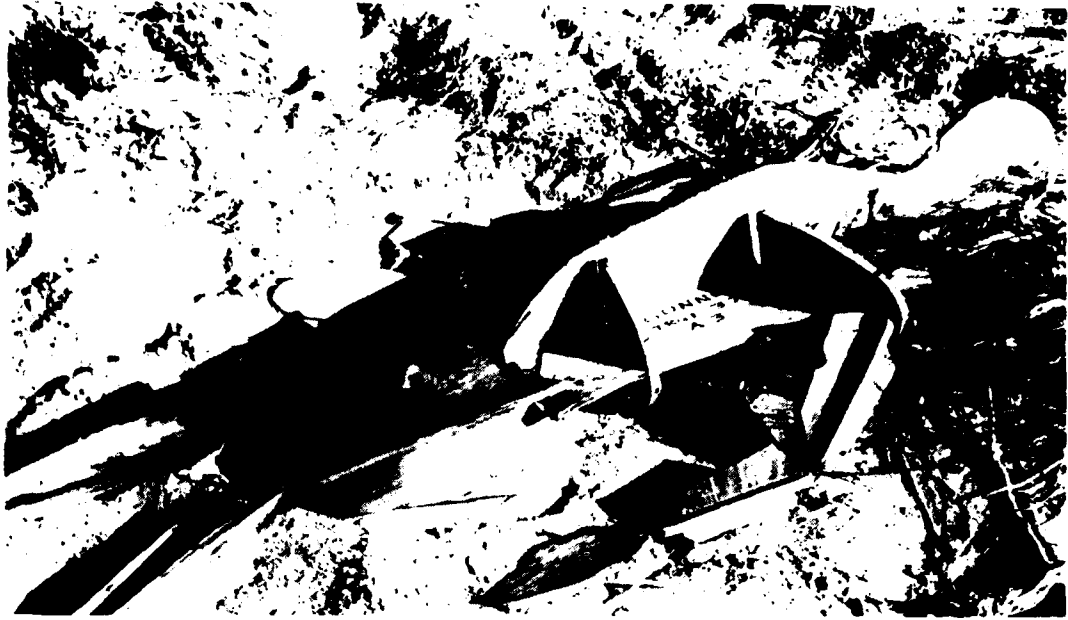

FIGURE 84. Gunner Manikin, Target 37, Showing Damage from Impact 9, Loader Fragment and burn Casualty.



FIGURE 85. Loader Manikin, Target 37, Showing Damage from Impact 9, Loader Fragment.

TARGET TANK NUMBER 38 DAMAGE SUMMARY

1. Description:

The attacking A-10 aircraft impacted target tank number 38 with 10 projectiles, fired from an aspect of 324 degrees (left front) during one pass at low altitude and low dive angle, while expending 89 rounds.

2. Kill Assessment:

100% interdiction M-Kill, resulting from the following projectile impacts, shown in Figure 86:

a. Perforations	:	0
b. Significant Impacts	:	5
c. Insignificant Impacts:		<u>5</u>

Total Impacts	:	10
---------------	---	----

3. Rationale for Kill Assessment:

A 100% interdiction type M-Kill after 5km travel was assessed due to impact 10 (Figure 87), which penetrated the left final drive, causing an oil leak (Figure 88) and possibly projectile and/or fragment damage to the gears. Minor track and suspension damage from 4 other impacts contributed to the kill.

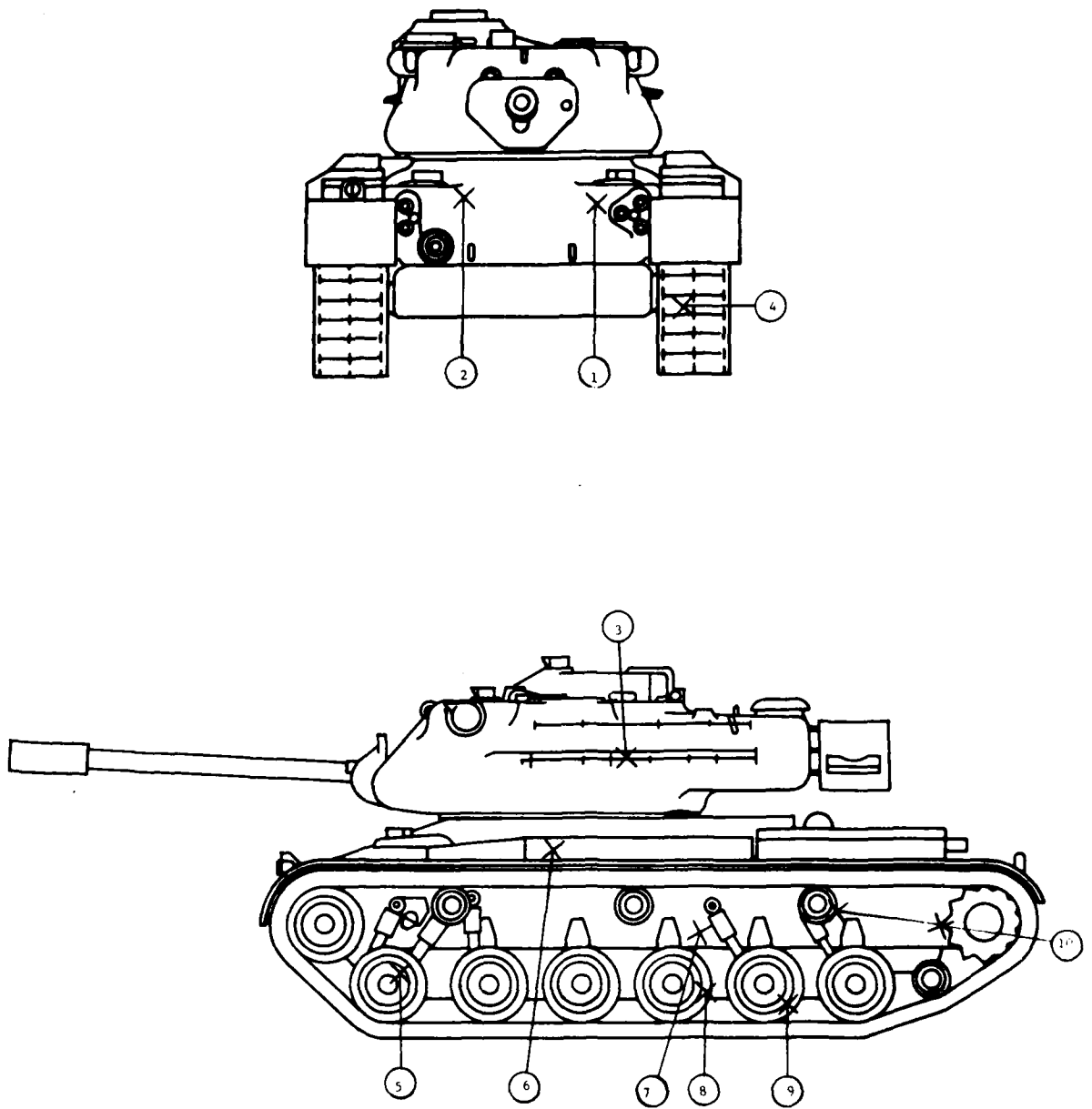

FIGURE 86. Impact Diagram, Target 38.

TARGET TANK NUMBER 39 DAMAGE SUMMARY

1. Description:

The attacking A-10 aircraft impacted target tank number 39 with 30 projectiles, fired from an aspect angle of 327 degrees (left front) during one pass at low altitude and low dive angle, while expending 100 rounds.

2. Kill Assessment:

100% interdiction M-Kill and 50% F-Kill, resulting from the following projectile impacts, shown in Figure 89:

a. Perforations	:	0
b. Significant Impacts	:	7
c. Insignificant Impacts:		<u>23</u>
Total Impacts	:	30

3. Rationale for Kill Assessment:

- a. M-Kill: A 100% interdiction type M-Kill after 5km travel was assessed because of Impact 24 (Figure 90), which destroyed the left #1 roadwheel hub, and because of cumulative damage to the track and suspension system resulting from 5 other impacts.
- b. F-Kill: The F-Kill was attributed solely to crew casualties. The tank commander was assessed a casualty from glass fragments because of Impact 17, shown in Figure 91, which shattered a vision block in his cupola.

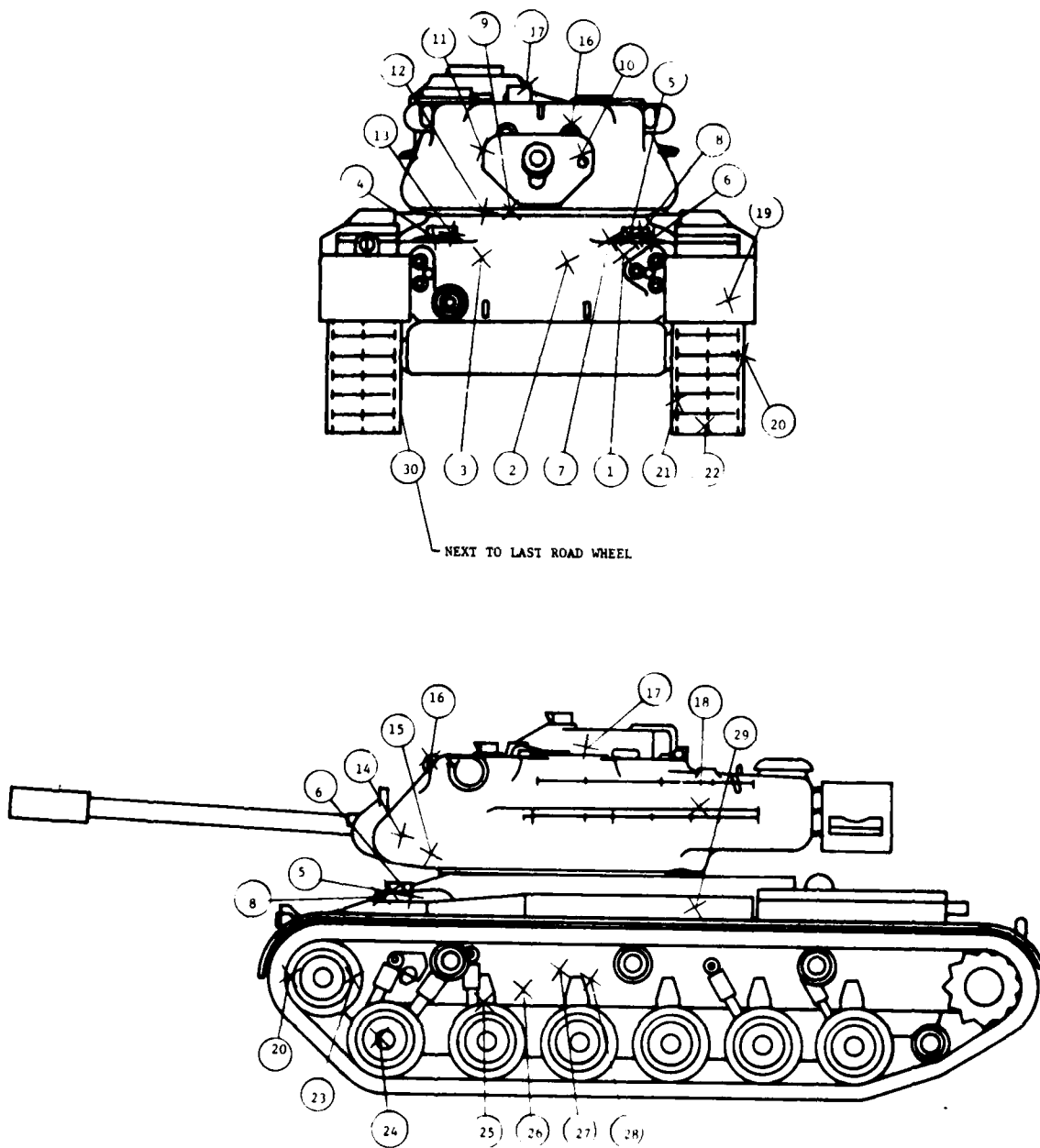

FIGURE 89. Impact Diagram, Target 39.



FIGURE 90. Impact Twenty-Four, Target 39, which Destroyed the Left #1 Roadwheel Hub.

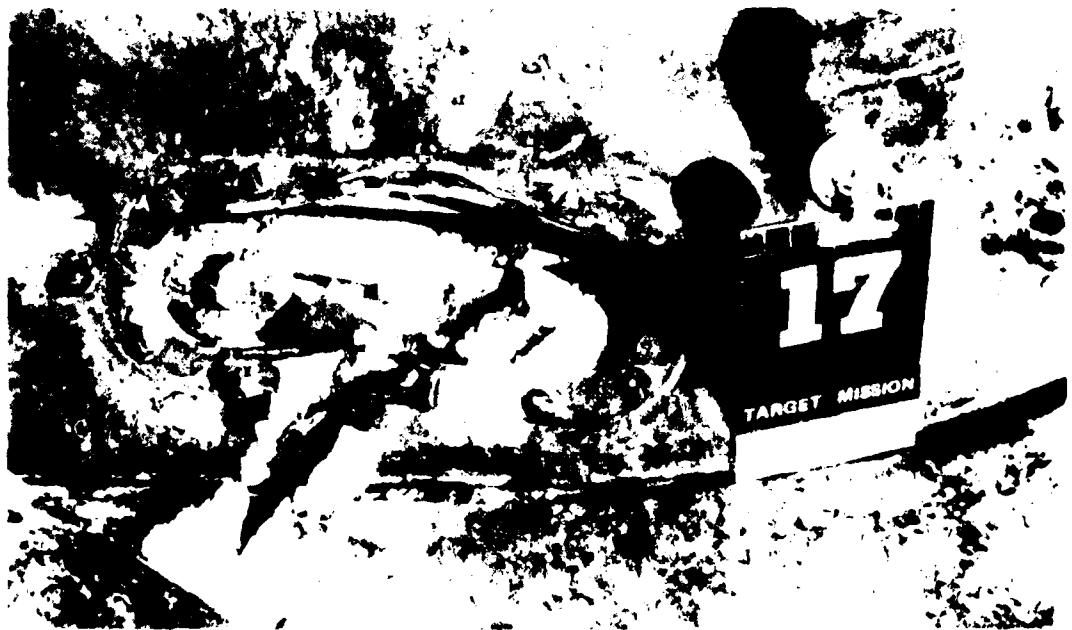

FIGURE 91. Impact 17, Target 37, which Destroyed a Vision Aid for the Commander and Destroyed the Main Drive Shaft.

TARGET TANK NUMBER 40 DAMAGE SUMMARY

1. Description:

The attacking A-10 aircraft impacted target tank number 40 with 71 projectiles, fired from an aspect angle of 320 degrees (left front) during one pass at low altitude and low dive angle, while expending 100 rounds.

2. Kill Assessment:

100% M-Kill, and 100% F-Kill, resulting from the following projectile impacts, shown in Figures 92 and 93:

a. Perforations	:	3
b. Significant Impacts	:	29
c. Insignificant Impacts:		<u>39</u>
Total Impacts	:	71

3. Rationale for Kill Assessment:

- a. M-Kill: Impact 2, shown in Figure 94, perforated the driver's hatch cover, causing the driver to become a casualty (Figure 95). Impact 33 destroyed the left #1 roadwheel hub, shown in Figure 96. Impacts 42 and 45 destroyed the left #2 roadwheel hub, shown in Figure 97. Impact 57 destroyed the left #3 roadwheel hub, shown in Figure 98. Impact 61 destroyed the left #4 roadwheel hub, shown in Figure 99. Impact 68 penetrated the left final drive, shown in Figure 100. Impacts 39 and 40 destroyed the left #1 track support roller, shown in Figures 101 and 102. Cumulative damage to the track and suspension system from 19 other impacts contributed to the kill.
- b. F-Kill: Impact 15, shown in Figure 103, perforated the left side of the commander's cupola and made him a casualty (Figure 104). Impact 3, shown in Figure 105, jammed the turret so that it could not be traversed. Impacts 12 and 13, which destroyed the gunner's periscope head, contributed to the kill.

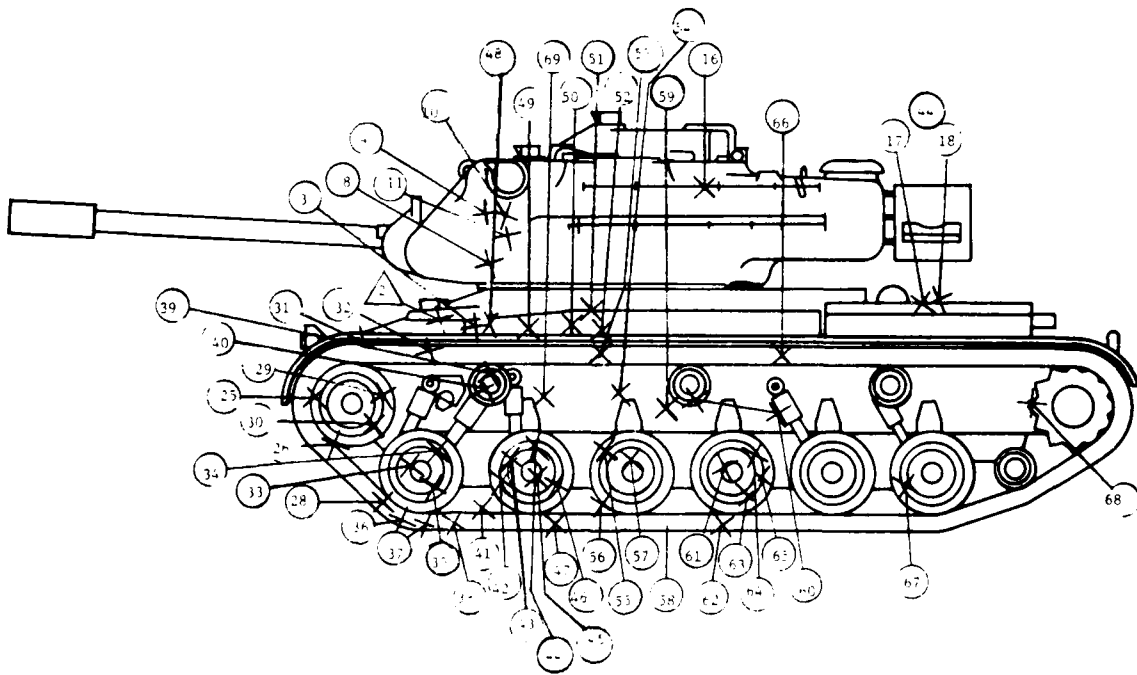
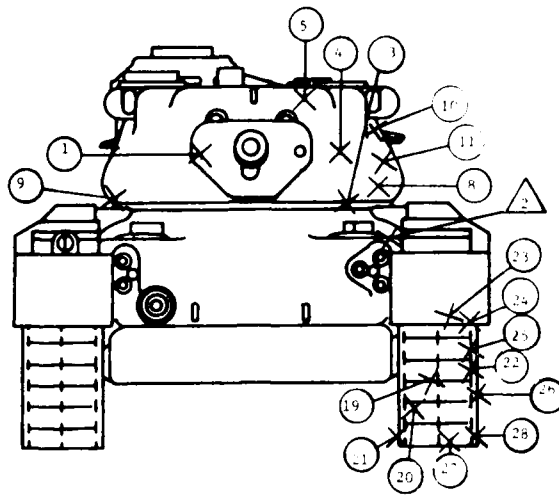

NOTE: Impacts 69, 70 and 71 not shown.

FIGURE 92. Impact Diagram, Front and Side, Target 40.

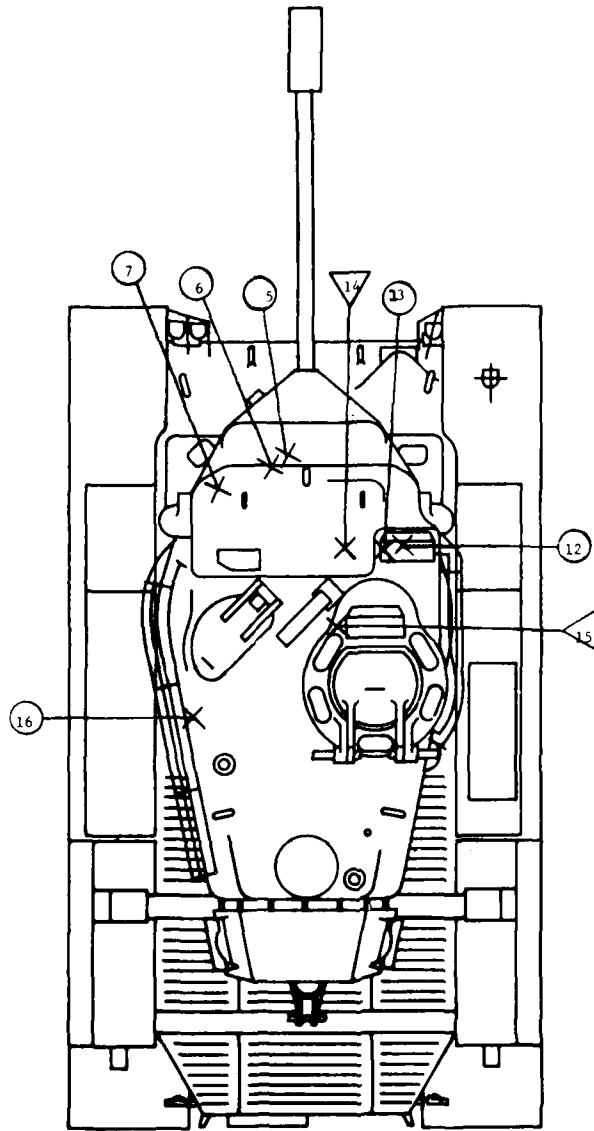

FIGURE 93. Impact Diagram, Top, Target 40.



FIGURE 94. Impact Two, Target 40, Perforation of Left Hull into Driver's Compartment.



FIGURE 95. Driver's Compartment, Target 40, Showing Damage from Impact Two.

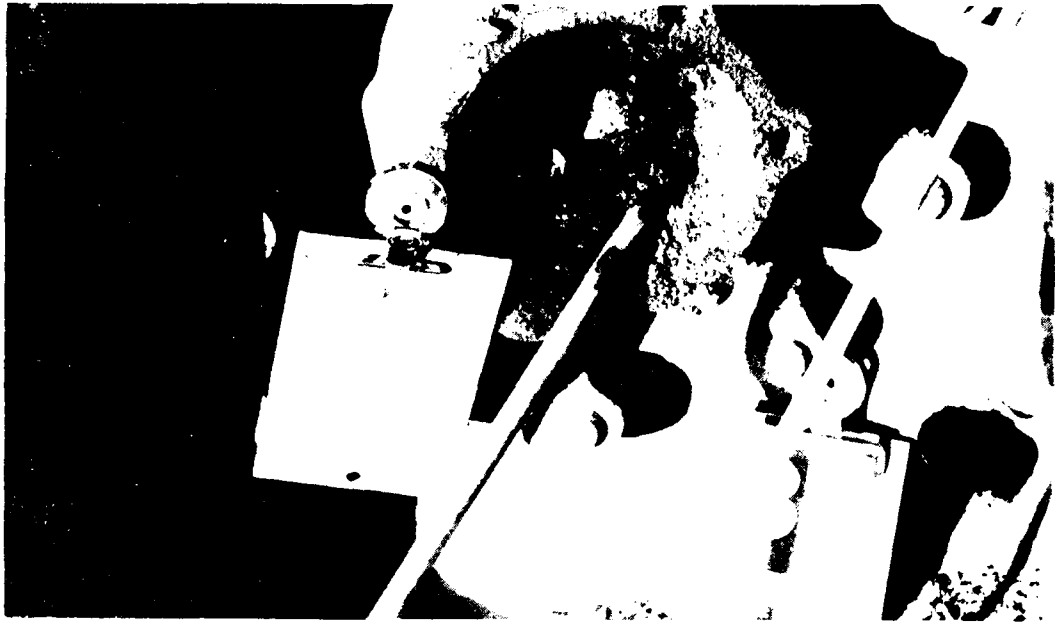

Figure 36. Impact Thirty-Three, Target 40, which Destroyed the Left #1 Roadwheel Hub.

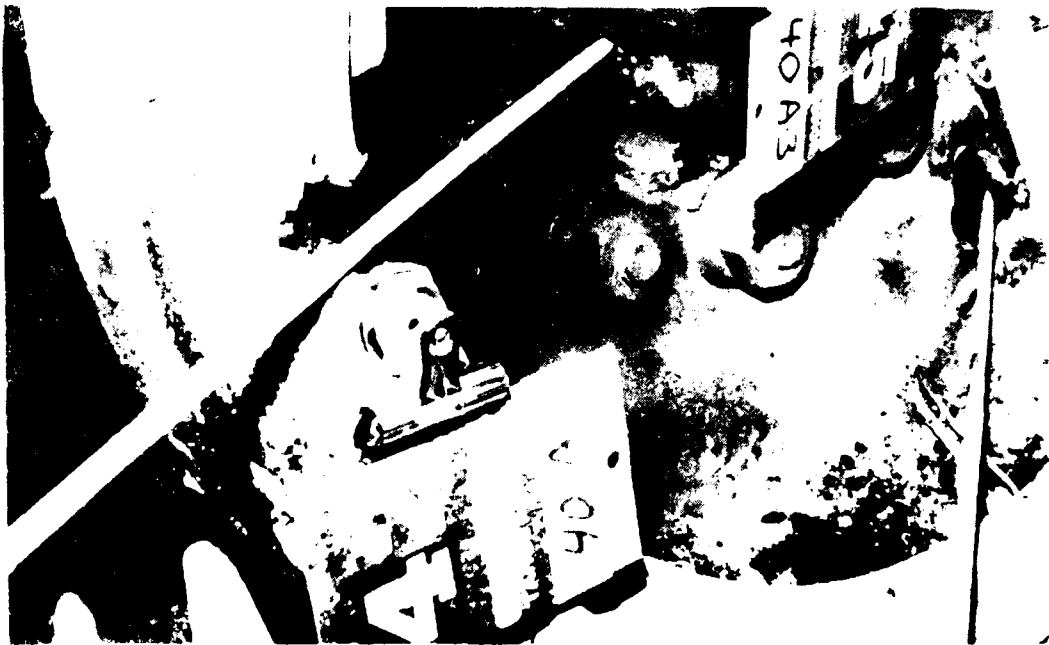

Figure 37. Impacts Forty-Two and Forty-Five, Target 40, which Destroyed the Left #2 Roadwheel Hub.



FIGURE 98. Remains of Ship-Seven, Target 4-3, which destroyed
the ship on 10/10/44.



FIGURE 99. Impact crater on the hull of the ship, the
remains of which are shown in Figure 98.



FIGURE 100. Impact Sixty-Eight, Target 40, which perforated the Left Final Drive.



FIGURE 101. Impact Thirty-Nine, Target 40, which perforated the Left #3 Track Support Roller.



FIGURE 10. (a) Target forty, Target 40, Contributor to Left Support Roller damage.



FIGURE 10. (b) Target forty, Target 40, which Perforated the Right Support Roller of the Company of Cobala.



FIGURE 104. Commander Manikin, Target 40, Showing Damage from Impact 15.



FIGURE 105. Impact Three, Target 40, which Jammed the Turret so that it would not Traverse.

TARGET TANK NUMBER 41 DAMAGE SUMMARY

1. Description:

The attacking A-10 aircraft impacted target tank number 41 with 41 projectiles, fired from an aspect angle of 318 degrees (left front) during one pass at low altitude and low dive angle, while expending 107 rounds.

2. Kill Assessment:

65% M-Kill, and 95% F-Kill, resulting from the following projectile impacts, shown in Figure 106:

a. Perforations	:	1
b. Significant Impacts	:	4
c. Insignificant Impacts:	:	<u>36</u>

Total Impacts	:	41
---------------	---	----

3. Rationale for Kill Assessment:

- a. M-Kill: Mobility was estimated to have been degraded by 65% due to crew casualties caused by Impact 18. Minor damage to the track and suspension system, caused by Impacts 27, 30, and 32, also made a contribution to the kill.
- b. F-Kill: A 95% F-Kill was assessed for Impact 18, shown in Figure 107, which perforated the commander's cupola into the fighting compartment and caused commander and gunner casualties. Impact 11, which destroyed the range finder blister, also made a significant contribution to the kill.

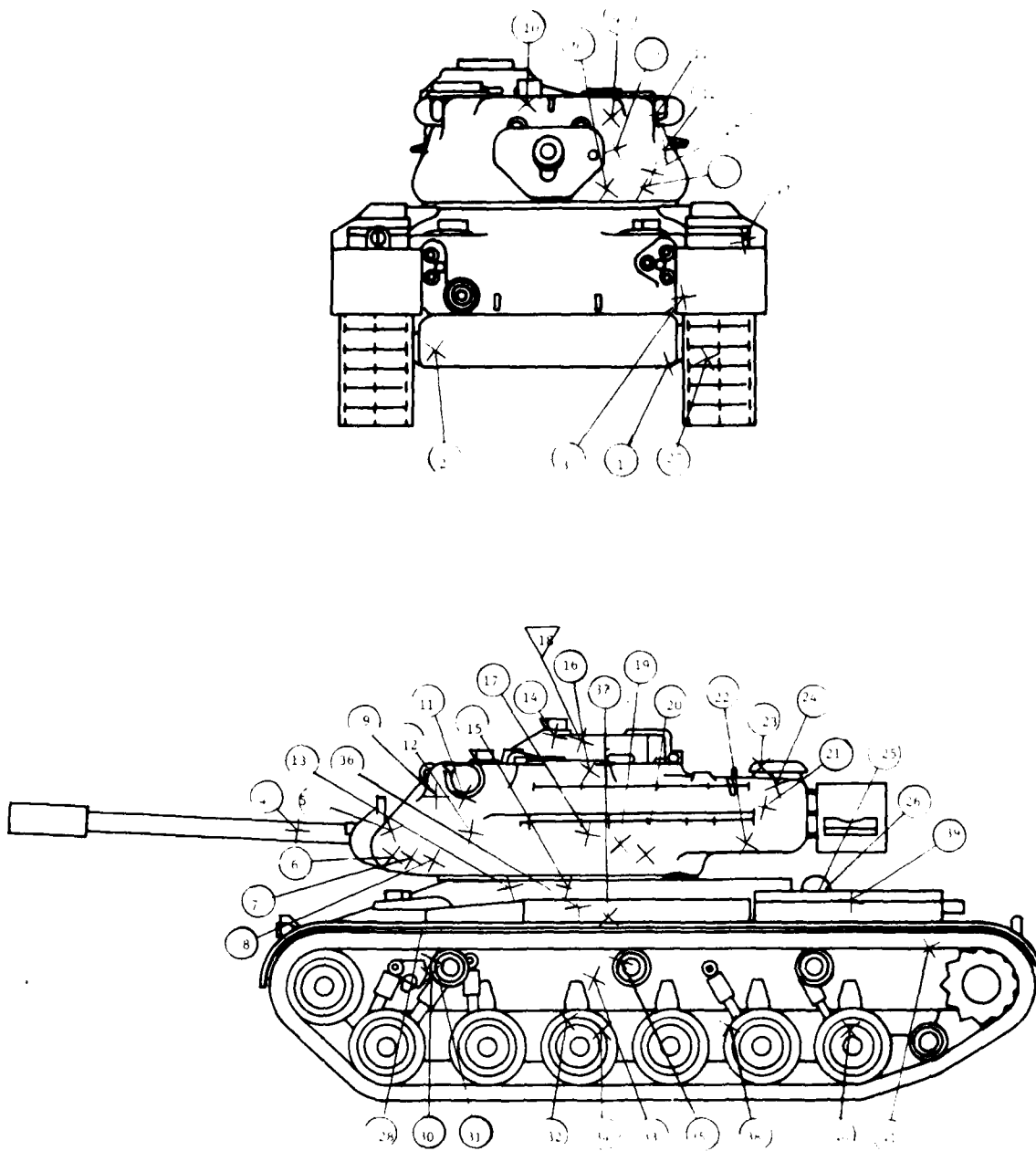

FIGURE 106. Impact Diagram, Target 41.



FIGURE 107. Impact Eighteen, Target 41, Perforation of
Commander's Copola, causing Casualties to
Commander and Gunner.

TARGET TANK NUMBER 42 DAMAGE SUMMARY

1. Description:

The attacking A-10 aircraft impacted target tank number 42 with 23 projectiles, fired from an aspect angle of 303 degrees (left front) during one pass at low altitude and low dive angle, while expending 101 rounds.

2. Kill Assessment:

100% interdiction M-Kill, resulting from the following projectile impacts, shown in Figure 108:

a. Perforations	:	0
b. Significant Impacts	:	7
c. Insignificant Impacts:		<u>16</u>

Total Impacts	:	23
---------------	---	----

3. Rationale for Kill Assessment:

A 100% interdiction type M-Kill, after an estimated 2000 meters travel, was assessed for Impacts 17 and 18, shown in Figures 109 and 110, respectively, which destroyed two (2) end connectors on opposite ends of the same track pins, leaving only the track center guide to hold the track together. Cumulative damage to the track and suspension system by 5 other impacts contributed to the kill.

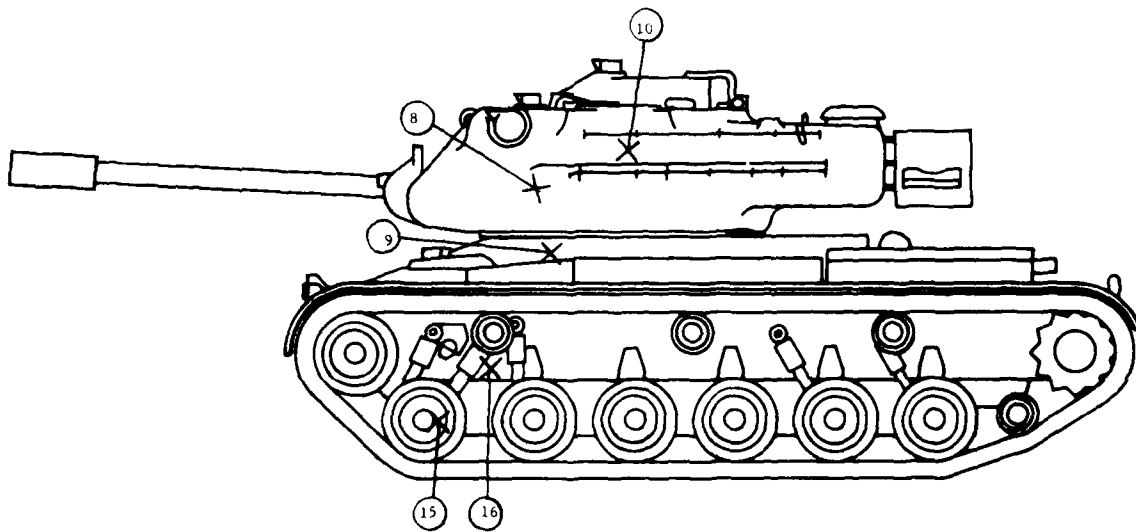
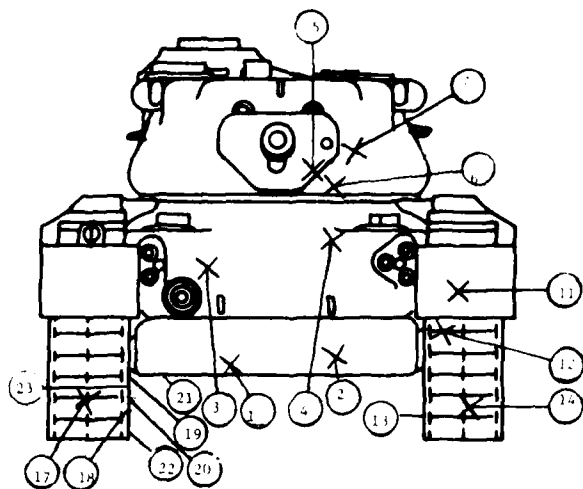

FIGURE 108. Impact Diagram, Target 42.



Figure 17. Skull of a large animal, possibly a bison, with a target mission tag.

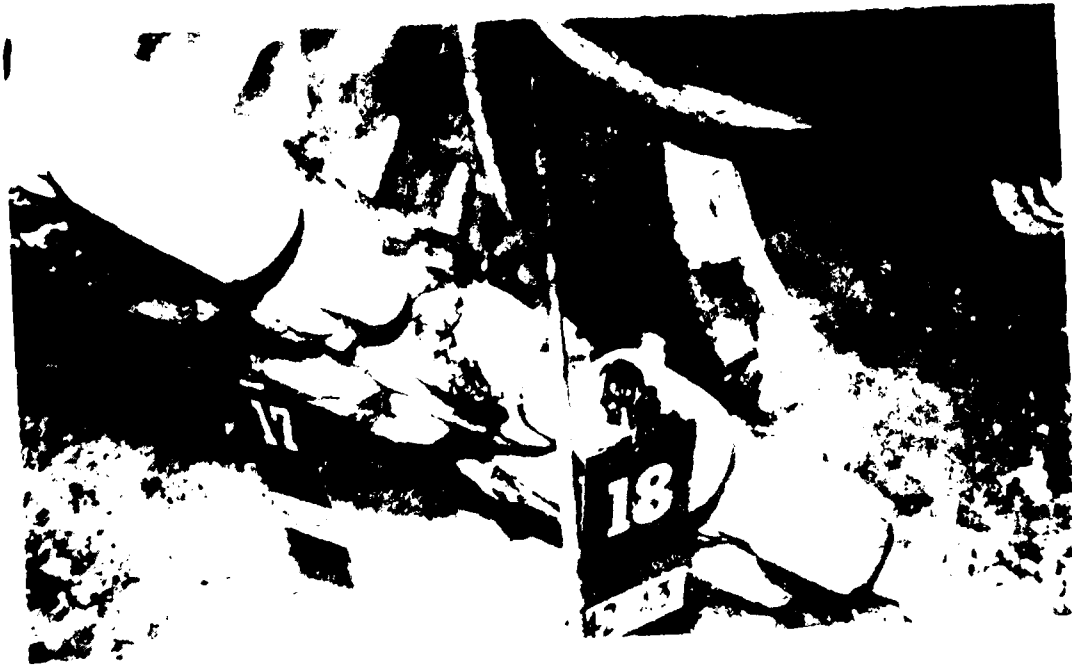

Figure 18. Skull of a large animal, possibly a bison, with a target mission tag.

TARGET TANK NUMBER 43 DAMAGE SUMMARY

1. Description:

The attacking A-10 aircraft impacted target tank number 43 with 30 projectiles, fired from an aspect angle of 313 degrees (left front) during one pass at low altitude and low dive angle, while expending 70 rounds.

2. Kill Assessment:

100% M-Kill and 100% F-Kill, resulting from the following projectile impacts, shown in Figure 111:

a. Perforations	:	5
b. Significant Impacts	:	13
c. Insignificant Impacts:		<u>12</u>

Total Impacts : 30

3. Rationale for Kill Assessment:

- a. M-Kill: Impacts 25 and 28 penetrated the left final drive, shown in Figures 112 and 113, respectively. Impact 22 destroyed the left #6 roadwheel hub (Figure 114). Cumulative damage to the track and suspension system, resulting from 10 other impacts, contributed to the kill.
- b. F-Kill: Impact 3 (Figure 115) perforated the left front turret, severed the recoil cylinder/replenisher flexible hose, and wounded the tank commander and gunner (figures 116 and 117). Four (4) other perforations of the hull had little or no behind-the-plate effects.

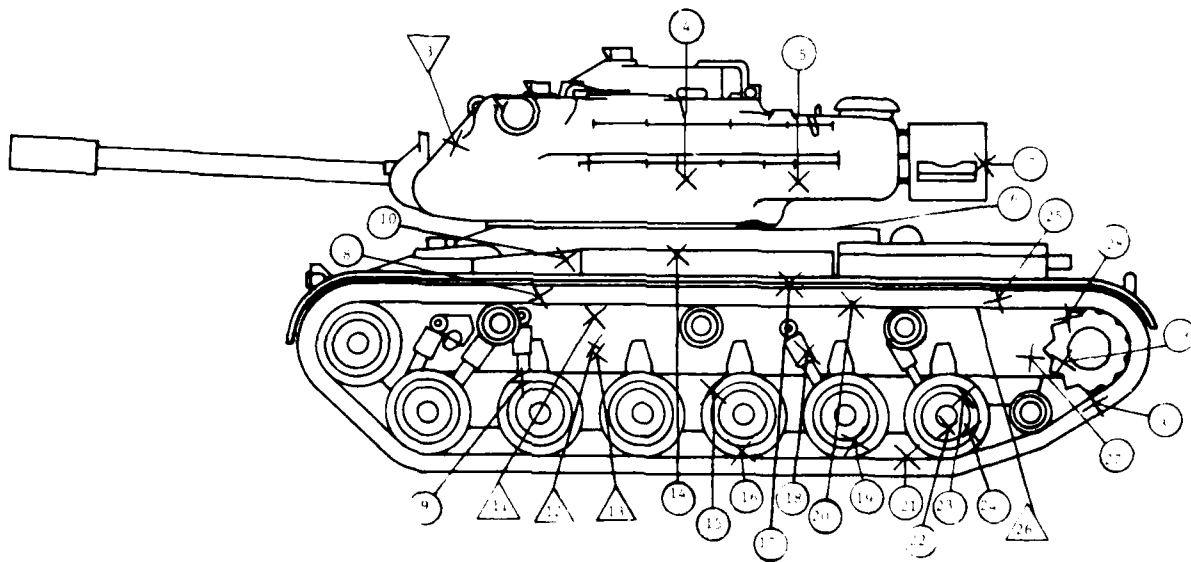
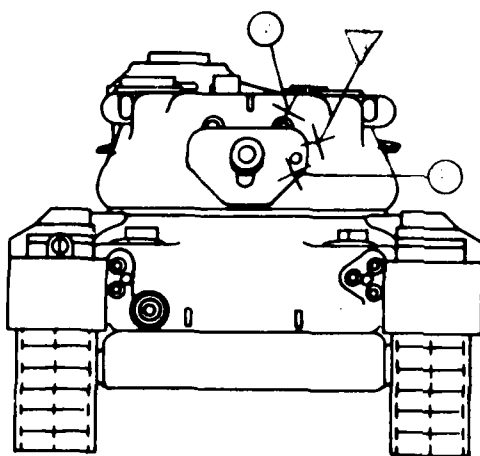

FIGURE 111. Impact Diagram, Target 43.

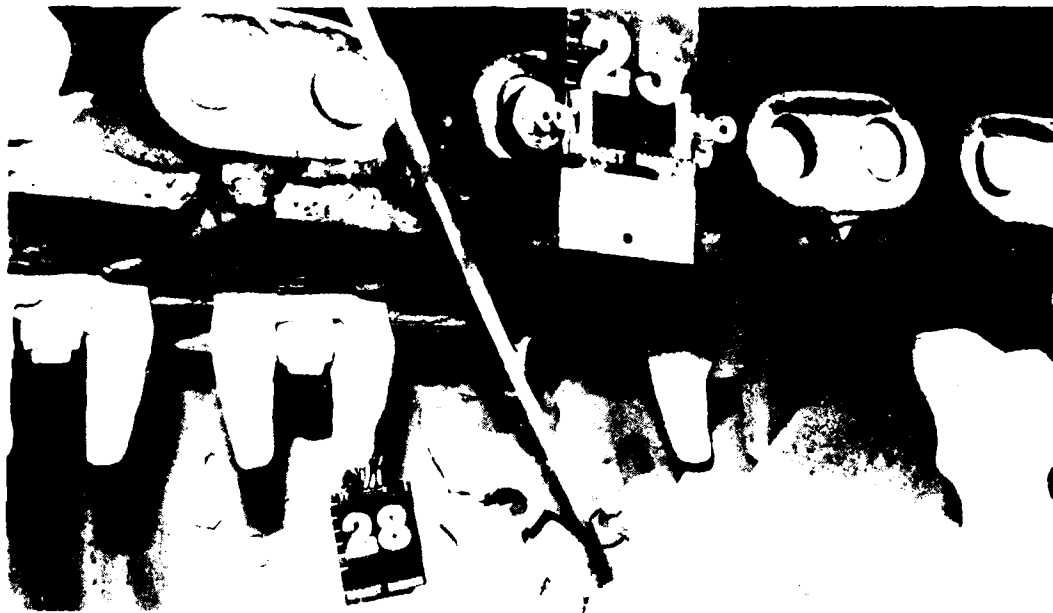

FIGURE 112. Impact Twenty-Five, Target 43, Showing Penetration of the Left Final Drive.



FIGURE 113. Impact Twenty-Eight, Target 43, Showing Damage to Left Inside Drive Sprocket and Penetration of Left Final Drive.



Figure 11. Impact Twenty-Two, Target 11. The photograph shows the bolt on roadwheel 11.

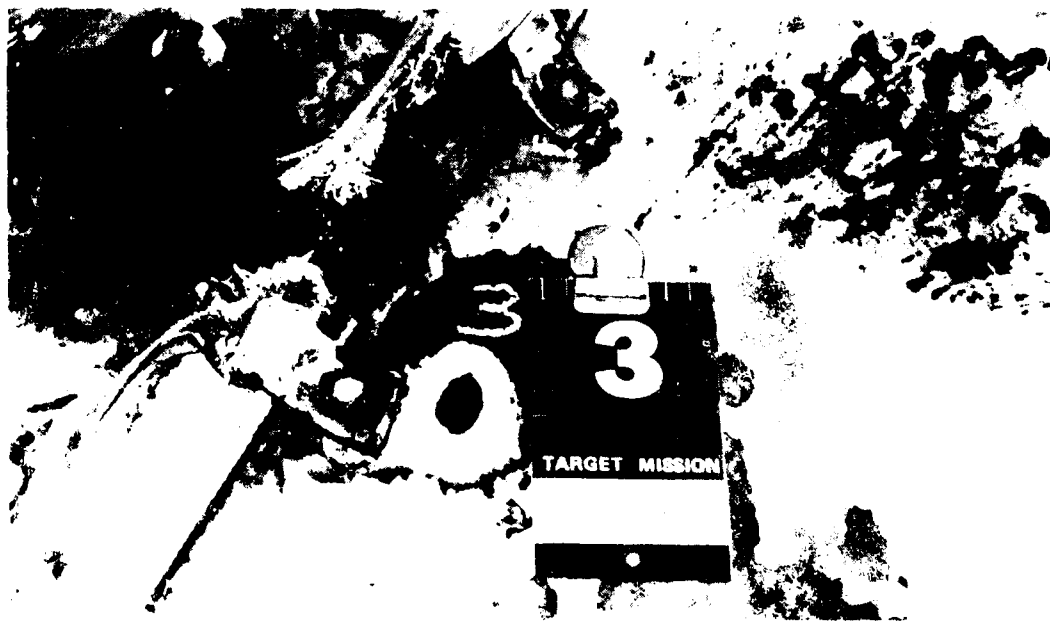

Figure 12. Impact Three, Target 11. The photograph shows the bolt on roadwheel 11.



FIGURE 11. [Illegible] [Illegible], Target 43, Showing Damage from [Illegible]

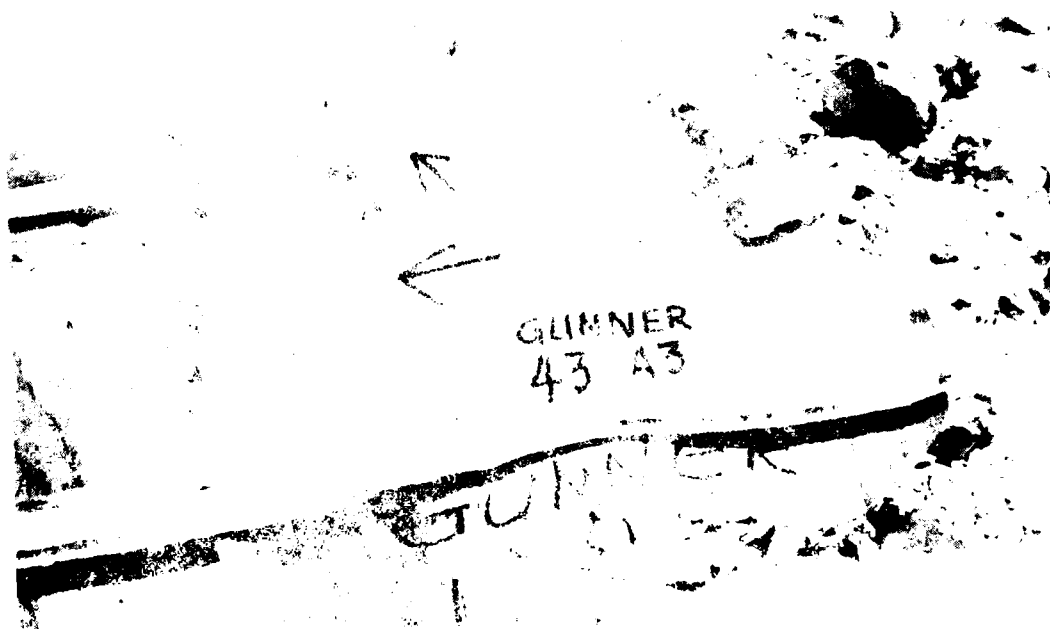

FIGURE 12. [Illegible] [Illegible], Target 43, Showing Damage from [Illegible]

TARGET TANK NUMBER 44 DAMAGE SUMMARY

1. Description:

The attacking A-10 aircraft impacted target tank number 44 with 13 projectiles, fired from an aspect angle of 322 degrees (left front) during one pass at low altitude and low dive angle, while expending 60 rounds.

2. Kill Assessment:

100% M-Kill, and 95% F-Kill, resulting from the following projectile impacts, shown in Figure 118:

a. Perforations	:	2
b. Significant	:	2
c. Insignificant Impacts:		<u>9</u>

Total Impacts	:	13
---------------	---	----

3. Rationale for Kill Assessment:

- a. M-Kill: Impact 11 (Figure 119) perforated the left hull and penetrated the oil cooler area; if the oil cooler had been in place, it would have been damaged or destroyed. Impact 12 ruptured the left final drive causing an oil leak. One other impact on the track destroyed one track center guide, making a minor contribution to the kill.
- b. F-Kill: Impact 1 (Figure 120) perforated the left top of the turret and caused casualties to two (2) crewmen (tank commander and gunner). No mechanical damage that would contribute to an F-Kill was observed.

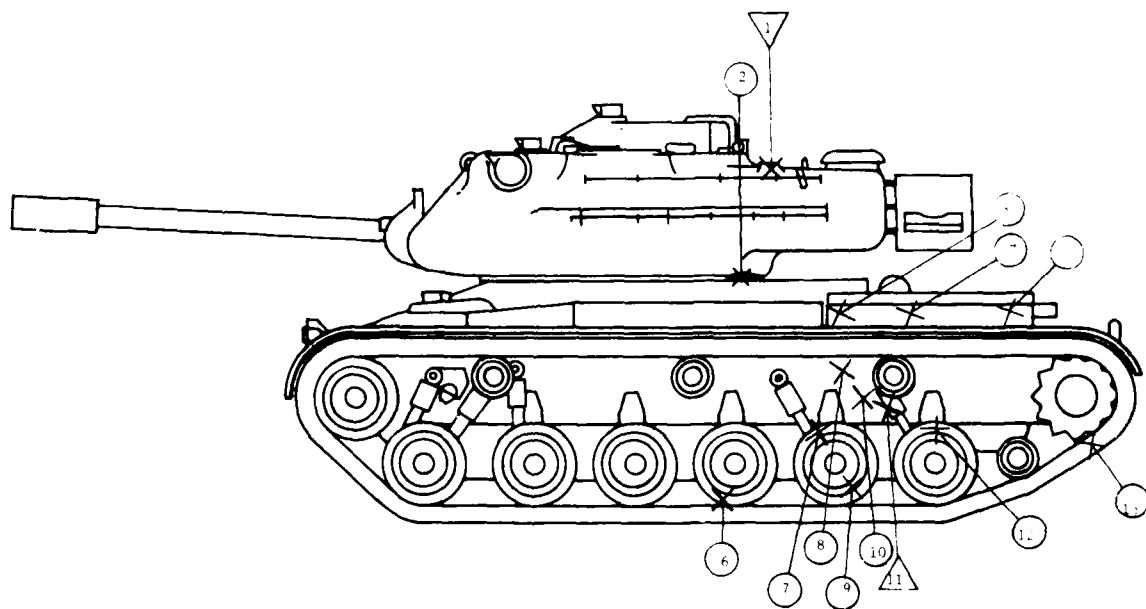

FIGURE 118. Impact Diagram, Target 44.



FIGURE 119. Impact Eleven, Target 44, which Perforated the Left Hull Armor into the Engine Compartment.



FIGURE 120. Impact Eleven, Target 44, which Perforated the Left Hull Armor into the Engine Compartment and Destroyed the Main Propeller.

TARGET TANK NUMBER 45 DAMAGE SUMMARY

1. Description:

The attacking A-10 aircraft impacted target tank number 45 with 55 projectiles, fired from an aspect angle of 322 degrees (left front) during one pass at low altitude and low dive angle, while expending 85 rounds.

2. Kill Assessment:

100% M-Kill and 10% F-Kill, resulting from the following projectile impacts, shown in Figure 121:

a. Perforations	:	0
b. Significant Impacts	:	20
c. Insignificant Impacts:		<u>35</u>
Total Impacts	:	55

3. Rationale for Kill Assessment:

- a. M-Kill: Impact 28 damaged the hub of the left #2 road-wheel, causing a breach of the seal assembly. Impact 40 (Figure 122) destroyed the left #4 roadwheel hub. Impacts 37 and 38, shown in Figures 123 and 124, respectively, destroyed the left #2 track support roller. Cumulative damage to the track and suspension system from 15 other impacts contributed to the kill.
- b. F-Kill: Impact 1 (Figure 125) penetrated one wall of the gun tube, degrading firepower by an estimated 10%.

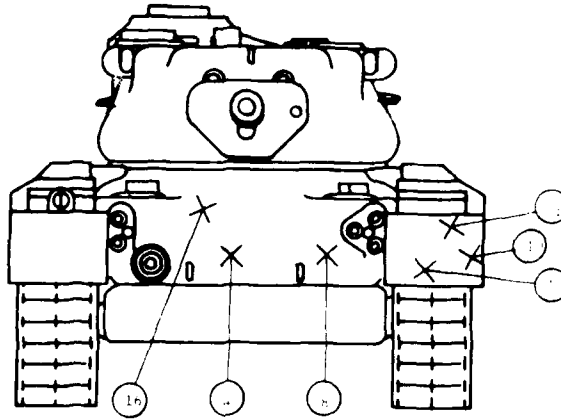

IMPACTS 3, 4, 5, 6, 7, and 14 ON BULLDOZER BLADE BRACKETS

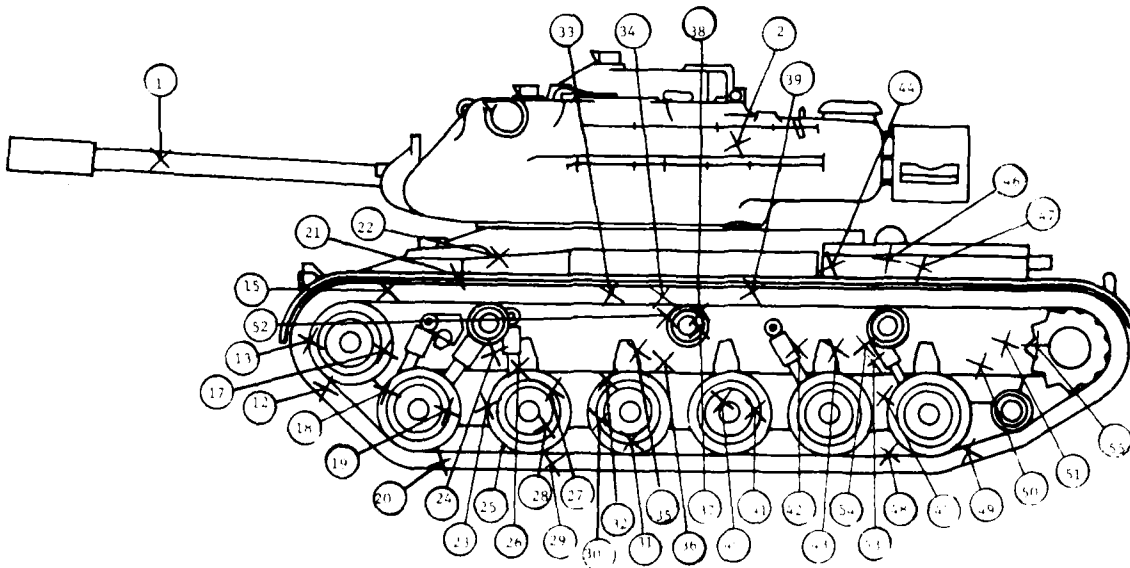

NOTE: Not shown in the impact distribution drawing above, but recorded in firing results are hits number 3, 5, 6, 7 and 14 on bulldozer blade, and its mounting bracketry and actuating hydraulic cylinder.

FIGURE 121. Impact Diagram, Target 45.



FIGURE 122. Face of forty, Target 45, 30/06/68, 100% head, 100% body, 44% wheel hub, 100% horn of 100%.



FIGURE 123. Face of forty, Target 45, 30/06/68, 100% head, 100% body, 44% wheel hub, 100% horn of 100%.



FIGURE 124. Impact Thirty-Eight, Target 45, Damage to #2 Track Support Roller, and 100% Loss of #5 Roadwheel Shock Absorber.

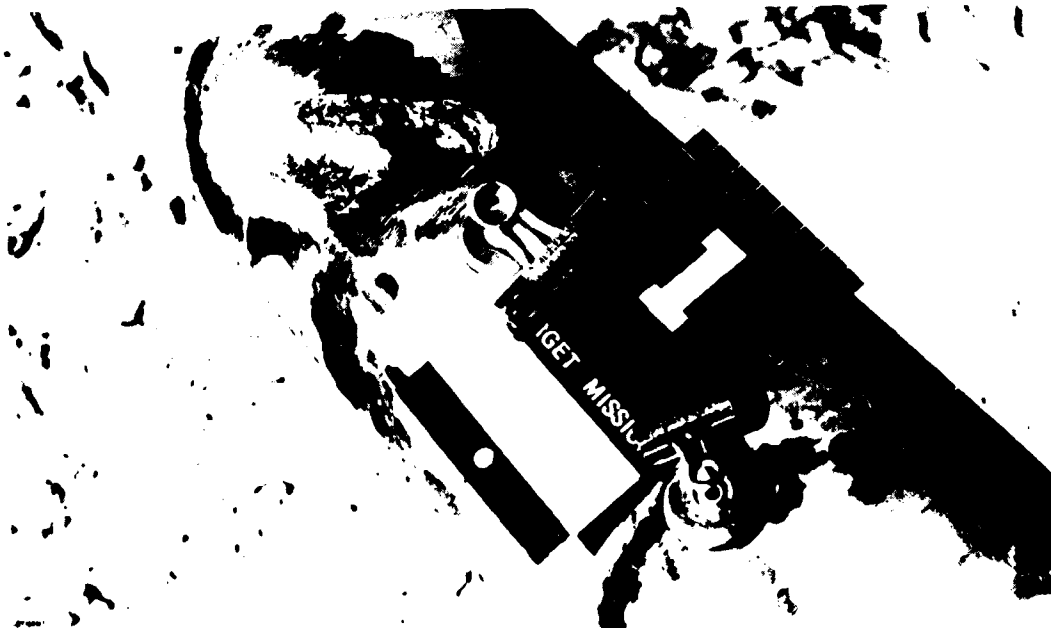

FIGURE 125. Impact One, Target 45, Top of Gun Tube Wall Perforated, Maximum Hole Dimension 37mm.

SUMMARY AND CONCLUSIONS

On 2 February 1979, at Nellis AFB, Nevada, the Combat Damage Assessment Team (CDAT) conducted firings of the A-10/GAU-8 weapon system against an array of 31 tanks, simulating a Soviet tank battalion deployed for an attack. The purpose of the firing test was to evaluate the effects of the 30mm API anti-tank ammunition fired out of the GAU-8 gun, under challenging conditions of engagement for the A-10/GAU-8 system, against Soviet tank formations realistically simulated by M-47 tanks stowed with main gun ammunition, diesel fuel, lubricating oil, and crew manikins. The pilots of the A-10 aircraft used in the firings conducted their attacks at low altitudes and low dive angles thus simulating attack below the minimum altitude for effective engagement by the opposing air defense systems using acquisition and fire control radar.

The firing test can be summarized in terms of the following data, collected and/or extracted from the firings:

Aircraft Parameters

- 1. Open-fire Speed (average) - - - - - 576 ft/sec
- 2. Altitude (average) - - - - - 387 feet
- 3. Dive Angle (average) - - - - - 3.23 degrees
- 4. Open-fire Slant Range (average) - - - 2820
- 5. Burst Length/Rounds fired (average) - 1.31 sec/86.4 rds
- 6. Number of Passes (primary) - - - - - 30
- 7. Target attack Aspects (average):

"A" Company,	"B" Company,	"C" Company,
Left front	Right rear	Left rear
(321 degrees)	(153 degrees)	(225 degrees)

Weapons Effects

Target Damage

- | | |
|-----------------------------------|--|
| 1. Rounds Fired - - - - - 2592 | 1. K-Kills - - - - - 2 |
| 2. Impacts - - - - - 919 | 2. M+F-Kills - - - - - 5 |
| 3. Direct Hits - - - - - 601 | 3. M-Kills - - - - - 11 |
| 4. Ricochets Off Ground - - - 235 | 4. F-Kills - - - - - 1 |
| 5. Perforations - - - - - 83 | 5. 100% M-Kills,
degraded F- - - - - 4 |
| | 6. 100% F-Kills,
degraded M- - - - - 3 |
| | 7. Degraded mobility
or firepower - - - - - 3 |
| | 8. Fired on but
missed - - - - - 1 |
| | 9. Not attacked - - - - - 1 |

These data and the more detailed base from which they were extracted can be arranged into measures of effectiveness for the A-10/GAU-8 system under conditions similar to those in the firing test, i.e., empirical combat simulation. The following values of

effectiveness are based on the firing test of 2 February 1979:

Measures of Effectiveness

Accuracy Related Ratio	Lethality Related Ratio:
$\frac{\text{Total Impacts (919)}}{\text{Rounds Fired (2592)}} = 0.355$	$\frac{\text{Perforations (83)}}{\text{Total Impacts (919)}} = 0.092$
$\frac{\text{Direct Impacts (684)}}{\text{Rounds Fired (2592)}} = 0.264$	$\frac{\text{Perforations (83)}}{\text{Direct Impacts (684)}} = 0.121$

Weapon System Effectiveness Ratio:

$\frac{\text{Tanks Neutralized (26)}}{\text{Passes (30)}} = 0.87$	$\frac{\text{Tanks K-Killed (2)}}{\text{Passes (30)}} = 0.07$
---	---

The 30 target tanks were attacked from the left front, left rear and right rear, and suffered the damage shown in Table I and Table A-1.

The data and measures summarized above, and the other data contained in this report, support the following inferences or conclusions:

1. The A-10/GAU-8 weapon system is capable, in realistic simulation of combat, of inflicting catastrophic, M-, and F-Kills on M-47 and similarly protected Soviet T-55 and T-62 main battle tanks.

2. The A-10/GAU-8 weapon system can effectively perforate the side and rear armor of the hulls and turrets of the M-47 and the similarly protected Soviet T-55 and T-62 main battle tanks when firing medium to long burst* of 30mm API ammunition at low-level** and medium range. Perforations, to the virtual exclusion of all other types of impacts by kinetic energy and shape charge projectiles, are those which cause catastrophic damage to main battle tanks by the ignition or detonation of internal fuel and ammunition. Given the substantial capability of the A-10/GAU-8 weapon system to perforate the side and rear armor of the more commonly fielded main battle tanks, the system allows the aviation commander to develop doctrine and operational tactics to catastrophically destroy main battle tanks.

3. The following test conditions resulted in extremely conservative results for the firings from the viewpoint of catastrophic kills:

- a. Diesel fuel at ambient temperature and motionless.
- b. Ammunition at ambient temperature.
- c. Lubricating Oils at ambient temperature.
- d. Ten out of 30 undesirable attack aspects from viewpoint of both catastrophic and mobility kills (left front).
- e. Twenty out of 30 undesirable attack aspects from viewpoint of catastrophic kills (right and left rear).

* (0.65 to 1.92 seconds, containing 40 to 129 rounds)

** Below the Soviet radar acquisition thresholds.

Uniqueness and Credibility of the Airborne Firing Tests

The test of 2 February 1979 had the purpose to verify the acceptability of manufactureres' lots of GAU-80 30mm API ammunition when fired under operational conditions against the most invulnerable and mobile Soviet ground weapon - the main battle tank. Acceptance testing normally consists of firings of randomly selected ammunition under carefully structured and instrumented range conditions to verify muzzle velocity, chamber pressure, etc. For armor piercing ammunition, tests would verify under range conditions the penetration/perforation capabilities of projectiles fired against armor plate and other target materials. Such tests would be conducted with scientific rigor (reproducibility), would establish the technical characteristics of the ammunition-and-gun system but have little credibility from the viewpoint of the effectiveness of the system as a damage agent against main battle tanks.

The sophisticated, painfully established models of tank vulnerability were not satisfactory to estimate damage from a light automatic cannon like the GAU-8 for the following reasons. The Army models estimate damage based on single impacts by large projectiles fired from ground weapons. The synergistic effects of numerous projectiles impacting almost simultaneously cannot be estimated with such models nor can the effects of the small sub-caliber depeleted Uranuim penetrators of the GAU-8 projectiles. No credible mechanism exists in the present computer models to estimate the number of impacts on target during one pass and the locations of those impacts. Existing models estimate damage also based on fragment impacts on inert internal components and liquids leaving the effects on actual ammunition, fuel, oil, etc. open to question.

In the test of 2 February 1979, the CDAT laid out the unprecedented number of 31 main battle tanks loaded with fuel, oil, live propellant, and crew manikins and arranged in a U.S. Army-approved attack formation simulating a Soviet tank battalion in a meeting engagement with NATO forces in Central Europe. To simulate a credible and challenging operational situation from the air, Tactical Air Command and Systems Command representatives for the firing agreed upon low altitude attack from over friendly territory and initial passes at four simulated ZSU-23/4 air defense cannon systems accompanying the simulated Soviet tank battalion in its attack. The attacks would be made by five pilots of the 57th Tactical Fighter using operational tactics involving low level ingress to the target area and initial long range, low level gunfire attack against the ZSU-23/4 air defense cannon followed by medium to short range gunfire attacks against the tanks. The pilots were limited to one pass against each target and an overall time of approximately ten minutes over the entire tank battalion. The time constraint was agreed upon to limit the exposure of the aircraft to air defense fire by the tank air defense machine guns, small arms, and a small number of SA-7 shoulder-fired missiles associated with a reinforced Soviet tank battalion, and the possibility of attack by an overlapping missile system positioned farther to the rear.

The resulting test was unique insofar as it represented an effective approximation of combat and therefore universal statistical results particularly from the viewpoint of the accuracy and lethality of the GAU-8 API ammunition. The test was also unique from the viewpoint of the scale of effort. The CDAT knows of no testing conducted to date in the Free World in which 31 combat loaded main battle tanks have been tactically arrayed and subjected to significantly free simulation of combat. The test team had to accept certain shortcomings in realism, for example, air attack within an arc of 180 degrees around the tanks and cease fire ranges of approximately 2,000 feet for peacetime safety reasons. The team additionally had to agree upon a scenario or single suboptimization of combat factors surrounding the placement of the Soviet tank battalion on the simulated battlefield. Observed from a slightly different perspective, the team was forced to attempt to achieve universal statistical results within a set of simulated combat factors which applied to ten minutes of aerial combat over the leading battalion of a soviet tank regiment in a meeting engagement in Central Europe. Yet, one is constrained to believe that the results observed would repeat themselves in (1) similar test scenarios, and (2) combat situations similar to the test scenarios.

APPENDIX A

Graphic and Summary Data

Table A-1 contains a summary of aircraft attack parameters against target tank array 3 of 2 February 1979. Figure A-1 depicts the aircraft attack aspect for each pilot and attack pass.

Table A-I. Array 3 Aircraft Attack Parameters
(2 February 1980)

Acft Tank Pass No.*	Open Fire Slant Rng (feet)	Dive Angle Open/Cease (degrees)	Altitude (feet)	Velocity Open/Cease (ft/sec)	Burst Length (Seconds)	Source
5/2	2699	4.0	463	586/589	1.46	HUD
5/1	2354	4.0	463	601/596	1.10	HUD
4/3	3294	6.0	513	622/638	1.35	HUD
3/4	2334	3.0	438	537/562	1.50	HUD
2/4	2487	4.0	363	583/584	1.50	PILOT
1/4	3677	3.0	463	591/591	1.60	HUD
4/2	3501	2.0	363	638/635	1.52	HUD
3/3	2155	3.0	363	637/637	1.08	HUD
2/3	2589	3.0	338	633/628	0.94	HUD
1/3	2803	2.0	373	635/630	1.29	HUD
2/9	2526	2.0	333	519/530	1.33	HUD
1/9	3766	2.0	363	552/552	1.58	HUD
2/8	2315	2.0	263	532/532	0.92	HUD
1/8	3160	0.0	363	557/556	1.63	HUD
2/7	2536	2.0	363	544/544	1.02	HUD
1/5	3186	0.0	363	583/583	1.60	HUD
1/7	2967	1.0	353	571/573	1.60	HUD
2/6	2607	2.0	263	544/544	0.65	HUD
2/2			TARGET NOT ATTACKED			
1/6	3173	0.0	353	539/539	1.60	HUD

Table A-1. (Concluded)

Acft Tank Pass No. *	Open Fire Slant Rng (feet)	Dive Angle Open/Cease (degrees)	Altitude (feet)	Velocity Open/Cease (ft./sec)	Burst Length (Seconds)	Source
4/8 27	2758	7.0	463	564/567	1.29	HUD
3/9 28	2102	8.0	463	524/535	1.21	HUD
4/7 29	2558	4.0	363	588/593	1.13	HUD
3/8 30	2173	4.0	413	537/537	1.27	HUD
3/7 31	2111	3.0	363	540/540	1.25	HUD
4/5 32	4776	4.0	263	584/588	1.92	HUD
3/6 33	2263	5.0	463	557/566	1.25	HUD
4/4 34	3061	3.0	363	601/601	1.40	HUD
3/5 35	2129	8.0	563	584/593	1.15	HUD
4/6 4	2630	6.0	463	588/593	1.19	HUD
2/5 7	2897	0.0	263	564/566	1.02	HUD
AVERAGES:	2820	3.23	387	576	1.31	

Nominal HUD Film Tolerances:

- Slant Ranges: Plus zero, Minus 150 Feet
- Dive Angles: Plus 0.5, Minus 0.5 Degrees
- Velocities: Plus 8.44, Minus 8.44 Feet Per Second
- Burst Times: Plus 0.0, Minus 0.021 Seconds

*1/3 means pilot 1, pass 3; 5/2 means pilot 5, pass 2; etc.

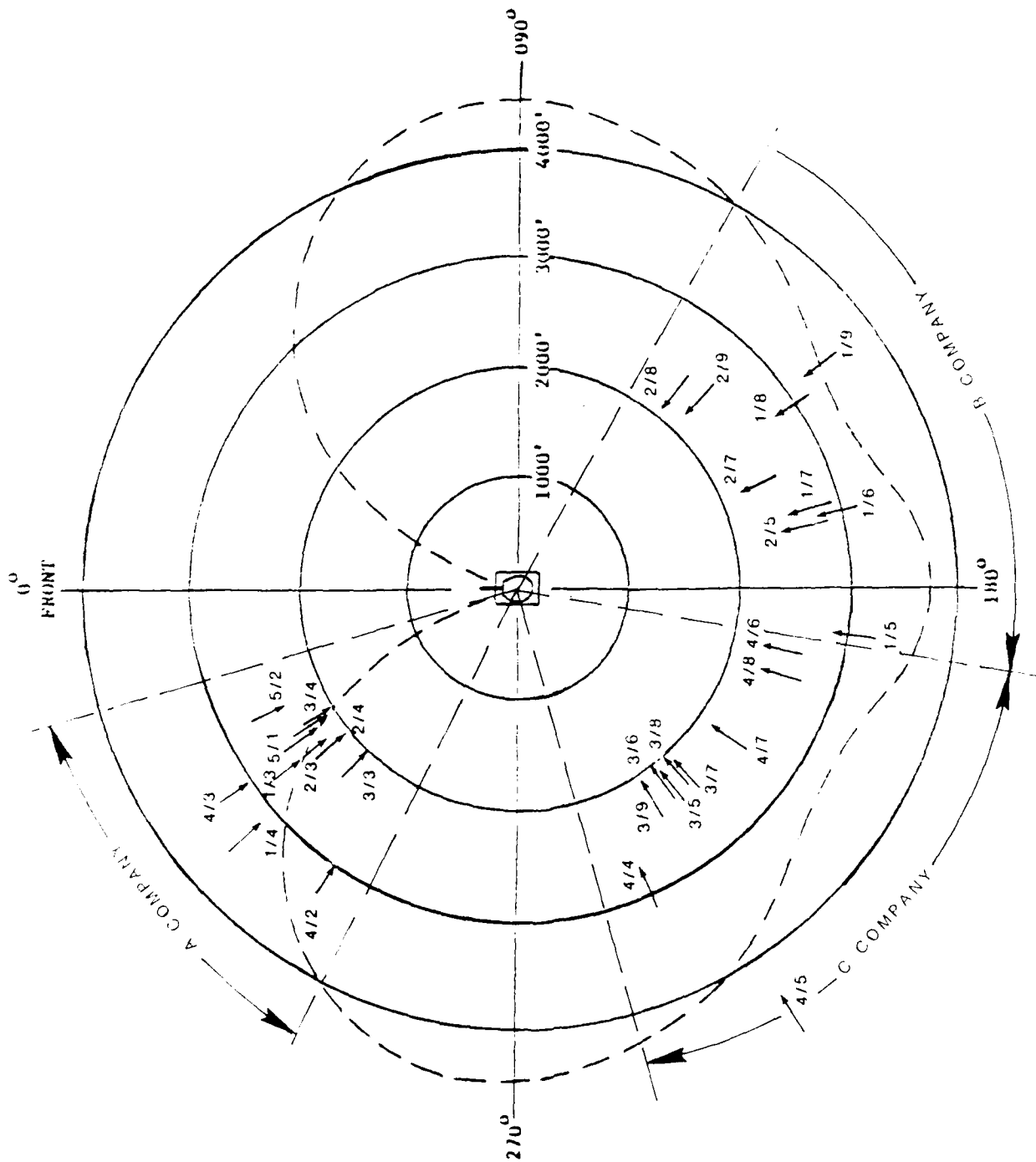

FIGURE A-1. Array 3 Attack Aspect Summary

APPENDIX B

DEFINITIONS

The terms used in this report are defined below:

IMPACT -- Any evidence of a projectile strike against any portion of the target. Ground ricochets striking the target were classified as "impacts".

PERFORATION -- Any rupture of the armored envelope caused by an impacting projectile which results in a complete rupture of an armored surface by the projectile or spall fragments. A perforation can occur only when the armor is impacted, except in cases of turret armor discontinuities around weapons, or vision and ranging devices. The word "perforation" was deliberately selected to avoid the ambiguities which may occur through use of the word "penetration". Behind-the-plate effects may or may not result from a perforation.

HIT -- Any impact not classified as a perforation.

MOBILITY KILL (M-KILL) -- Loss of tactical mobility, resulting from damage which cannot be repaired by the crew on the battlefield. A tank is considered to have sustained a 100% M-kill when it is no longer capable of executing controlled movement on the battlefield. Mobility is DEGRADED when a tank can no longer maintain position in its formation.

FIREPOWER KILL (F-KILL) -- Loss of tactical firepower, resulting from damage which cannot be repaired by the crew on the battlefield. A tank is considered to have sustained a 100% F-Kill when it is incapable of delivering controlled fire from its main armament. Firepower is DEGRADED when a tank can no longer maintain its "normal" rate-of-fire, velocity, accuracy, time to shift targets, etc.

CATASTROPHIC KILL (K-KILL) -- A tank is considered to have sustained a K-Kill when both an M-Kill and a F-Kill have occurred as the result of killing fires and explosions from ignited fuel and/or ammunition. A tank which has suffered a K-Kill is considered not to be economically repairable and, by U.S. standards, would be abandoned on the battlefield.

ATTACK ASPECT -- The angle of approach of the aircraft with respect to the orientation of the tank with zero degrees representing the front of the tank (gun forward) and 180 degrees representing the rear of the tank.

SIGNIFICANT IMPACTS -- Impacts which damage systems, components or sub-systems resulting in their destruction or partial loss of function. This type of damage contributes to the assessed kill.

INSIGNIFICANT IMPACTS -- Impacts which damage non-critical structural, convenience, or accessory components and which may result in their destruction or partial loss of function, but with no impact on mobility or firepower considerations. Good maintenance practices contemplate repair or replacement of such items at the earliest opportunity consistent with accomplishment of the mission.

DISTRIBUTION LIST FOR LAVP RESULTS

	No. Copies
1. Mr. R.L. Saley Aerojet 1025 Connecticut Avenue, N.W. 12th Floor Washington, DC 20036	1
2. Mr. Marshall Hoyler, Analyst Congressional Budget Office 2nd & D Streets, S.W. Washington, DC 20024	1
3. Dr. John Barmby U.S. General Account Office 441 C Street N.W. Washington, DC 20548	1
4. Lt. Col. Neal Edward Tash USAF/XOOTR Pentagon Washington, DC 20330	1
5. Col. John R. Boyd (rtd.) OASD/PA&E, Rom 2C 281 Pentagon Washington, DC 20301	1
6. Dept. of the Air Force The Albert F. Simpson Historical Research Center/HOH Arthur W. McCants, Jr., Lt. Col. Chief, Oral History Branch Maxwell Air Force Base, Albama 36112	1
7. 354 TFW/DOW Myrtle Beach AFB, SC 29577	3
8. 81 TFW/CC RAF Bentwaters APO NY 09755	1
9. 81 TFW/DO RAF Bentwaters APO NY 09755	10
10. 23 TFW/DO England AFB, LA 71301	2

11. USAF/TFWC/TE 5
Nellis AFB, NV 89191
12. Mr. Jerome H. Stolarow 1
U.S. General Accounting Office
441 C Street, N.W.
Washington, DC 20548
13. MGEN Bernard E. Trainor, USMC 1
Education Center
MCDEC
Quantico, VA 22134
14. Mr. William Lind 1
Office of Senator Gary Hart
254 Russel Building
Washington, DC 20510
15. Deputy Chief of Staff for Intelligence 5
Headquarters
Tactical Air Command
Colonel Herrmann
Langley AFB, VA 23665
16. Mr. James O. Carson 1
Central Intelligence Agency/OSR
Washington, DC 20505
17. Mr. Robert Korn 1
Central Intelligence Agency
Washington, DC 20505
18. Mr. Richard R. Hallock 3
Intrac, Inc.
606 Wilshire Boulevard - Suite 400
Santa Monica, CA 90401
19. Library 1
(Attention: Reports Section)
Naval Postgraduate School
Monterey, CA 93940
20. Mr. C.M. Gordon 1
GE
777 14th, N.W.
Washington, DC 20005
21. Maj. M.R. Janay, USMC 1
HQ DARCOM - Code DRCGS-F
5001 Eisenhower Avenue
Alexandria, VA 22304

22.	Mr. Raymond R. McEachin P.O. Box 273 Hazlehurst, GA 31539	5
23.	K.R. Town, USMC Headquarters, U.S. Marine Corps Washington, DC 20380	1
24.	Mr. E. Elko AOMC 9236 East Hall Road Downey, CA 90241	1
25.	Mr. K.H. Wolvington GE Lakeside Avenue Burlington, VT 05401	2
26.	Mr. Kwai Chan U.S. General Accounting Office 441 C Street, N.W. Washington, DC 20548	1
27.	HQ TAC/DOOO Langley AFB, VA 23665	2
28.	USAF Academy Library USAF Academy, CO 80840	2
29.	Albert F. Simpson Historical Research Center Attention: Mr. Fletcher Maxwell AFB, AL 36112	2
30.	CMDR Naval Air Systems Command Attention: PMA 235 B Washington, DC 20361	1
31.	DASD/ISA/ED Room 4D800 The Pentagon Washington, DC 20301	1
32.	Lt. Col. Howard J. Pierson 139 Booker Street Little Rock, AR 72204	5

33.	USAF DCS, Plans & Operations Tactical Division BF 939B The Pentagon Washington, DC 20301	2
34.	USAF DCS/Programs & Resources Director of Programs Tactical Branch 4C152 The Pentagon Washington, DC 20301	2
35.	USAF DCS/Research & Development Directorate of Operational Requirements & Development Plans Tactical Division 5E381 The Pentagon Washington, DC 20301	2
36.	HQ TAC/DO O Langley AFB, VA 23665	3
37.	Mr. Andrew W. Marshall Director Net Assessment Room 3A930 Pentagon Washington, DC 20301	3
38.	Dr. James A. Ross Institute for Defense Analyses 400 Army Navy Drive Arlington, VA 22202	1
39.	Lt. Col. Lanny T. Lancaster HDQ TAC/CCS Langley AFB, VA 23665	2
40.	Mr. Thomas E. Gaines P.O. Box 225907 Flight Corporation Dallas, TX 75265	1
41.	Mr. Emil H. Seaman Aerojet Ordnance Company 9236 East Hall Road Downey, CA 90241	1

42.	Mr. Charles E. Myers 2000 S. Eads #113 Arlington, VA 22202	1
43.	Mr. David G. Opheim Honeywell, Inc. 600 Second Street, N.E. Hopkins, MN 55343	1
44.	Mr. John D. Fafenberg HQ USAF/ING - Pentagon, Room 4A882 Washington, DC 20330	1
45.	HQ TAC/XP Langley AFB, VA 23665	1
46.	USAF TFWC/SA Nellis AFB, NV 89191	1
47.	57 FWW/DO Nellis AFB, NV 89191	1
48.	12 AF/DO Bergstrom AFB, TX 78743	2
49.	9 AF/DO Shaw AFB, SC 29152	2
50.	CINCUSAFE/DO Ramstein AFB APO 09012	4
51.	Major General Kelly, USAF TFWC/CC Nellis AFB, NV 89191	2
52.	66 FWC/CC Nellis AFB, NV 89191	10
53.	Thomas P. Christie DASD (Tactical Air Program) iA&E Room 2E330 Pentagon Washington, DC 20301	10
54.	Maj. Davies (ASD/YXA) USAF/Aeronautical Systems Division A-10 System Program Office Directorate of Armament Wright-Patterson AFB, OH 45433	10

55. Battelle 5
Columbus Laboratories
Tactical Technology Center
Room 13-4127
Attention: Mr. J. Tuck Brown
505 King Avenue
Columbus, OH 43201
56. HQ USAF 2
DSC/RDF
Pentagon - 4D283
Washington, DC 20330
57. Maj. Robert. K. Redlin 1
Commandant of the Marine Corps
Code R&P
Headquarters, U.S. Marine Corps
Washington, DC 20380
58. Lt. Gen. P.X. Kelly, USMC 2
Commander
Rapid Deployment Joint Task Force
MacDill AFB, FL 33608
59. Lt. Col. G. W. Keiser (Code RP) 1
U.S. Marine Corps
Requirements & Programs
Washington, DC 20380
60. Mr. Richard Eppard 1
Central Intelligence Agency
Office of Logistics
Washington, DC 20505
61. Mr. Rudolf A. Endors 1
10101 Colebrook Avenue
Potomac, MD 20854
62. Maj. Gen. Thomas P. Lynch 1
Commanding General
U.S. Army Armor Center
Fort Knox, KY 40121
63. Maj. Barry D. Watts 1
OSD/Office of Net Assessment
Pentagon - 3A930
Washington, DC 20301
64. HQ TAC/CC 2
Langley AFB, VA 23665

65.	Library, Code 0212 Naval Postgraduate School Monterey, CA 93940	2
66.	Department Chairman Dept. of National Security Affairs Naval Postgraduate School Monterey, CA 93940	2
67.	Professor Russel H.S. Stolfi Dept. of National Security Affairs Naval Postgraduate School Monterey, CA 93940	20
68.	AFIT/CIP (Library) Wright-Patterson AFB, OH 45433	2
69.	Col. Wayne E. Davis 1411 Gemini Circle Moody AFB Valdosta, GA 31601	1
70.	Brig. Gen. W.S. Harpe 14 TFW Columbus, MS 39701	5
71.	354 TFW/DCM Myrtle Beach AFB, SC 29577	1
72.	TAC/DR Langley AFB, VA 23665	1
73.	CIA/HQ Washington, DC 20505	2
74.	Mr. P.M. Sprey Box 264, R.D. 1 Glenn Dale, MD 20769	5
75.	Mr. Mike Mecca Fairchild Industries Germantown, MD 20767	2
76.	Industrial College of the Armed Forces Library Ft. Lesley J. McNair Washington, DC 20319	1

77.	Maj. Gerald H. Felix, USAF 112 TFG Greater Pittsburgh Airport Pennsylvania Air Guard Pittsburgh, PA 15180	3
78.	USMCDEC Firepower Division Air Branch/Code D092 Attention: Ms. Kearns Quantico, VA 22134	5
79.	USAF TAWC Eglin AFB, FL 32542	1
80.	Headquarters U.S. Marine Corps Chief of Staff Arlington Annex Room 2010 Columbia Pike & Arlington Ridge Road Arlington, VA 20370	2
81.	USAF Air University Library Maxwell AFB, AL 36112	2
82.	CMDR, Naval Weapons Center Attention: Mr. Bates China Lake, CA 93555	2
83.	Deputy Director/Commanding Officer Ballistic Research Laboratory Building 328 Aberdeen Proving Ground, MD 21005	1
84.	GE, Armament Systems Dept. Director Lakeside Ave. Burlington, VT 05401	1
85.	HQ TAC/DO Langley AFB, VA 23665	3
86.	354 TFW/CC Myrtle Beach AFB, SC 29577	5
87.	23 TFW/CC England AFB, LA 71301	1

88.	356 TFS/DO Attention: Maj. Jenny Myrtle Beach AFB, SC 29577	2
89.	355 TFW/DO (A-10) Davis Monthan AFB, AZ 85707	5
90.	Herrn Dr. Stahl Bundesarchiv-Militararchiv <u>78 Freiburg im Breisgau</u> Weisenstr 10 West Germany	1
91.	Mr. Richard E. Tuck U.S. General Accounting Office 441 C Street, N.W. Washington, DC 20548	1
92.	Col. Paul N. Chase HQ USAF AF SAGP Pentagon - 1D373 Washington, DC 20330	1
93.	Mr. Peter McDavitt Honeywell 600 Second Street, N.E. Hopkins, MN 55343	1
94.	Col. Carl Case Fighter Division Air Force Studies & Analysis Pentagon - 1D380B Washington, DC 20330	1
95.	Dr. Dieter H. Schwebs U.S. General Accounting Office 441 C Street, N.W. Room 6478 Washington, DC 20548	1
96.	Col. Michael L. Wardinski HQ Department of the Army DAMI-RT Pentagon - BF722 Washington, DC 20310	1

97.	Mr. John Sloan HQ Department of the Army DAMI-RT Pentagon - BF722 Washington, DC 20310	1
98.	Mr. W.R. Beuch HQ Department of the Army DAMI-RT Pentagon - BF722 Washington, DC 20310	1
99.	FMC Corporation 1105 Coleman Avenue Box 1201 Attention: Mr. Don Loughlin, MC510 San Jose, CA 95108	1
100.	Lt. Col. J.W. Lent HQ MC (Code RFR-7) Washington, DC 20380	1
101.	Mr. Arthur G. Hanley Central Intelligence Agency Procurement Management Staff Washington, DC 20505	1
102.	50 TFW/CC APO NY 09109	1
103.	50 TFW/DO AOI BT 09109	3
104.	50 TFW/DO Attention: Maj. Ratley APO NY 09109	5
105.	Col. Faybanic AWC/DAUM Maxwell AFB, AL 36112	1
106.	Mr. Cobleigh Hughes Aircraft Canoga Park, CA 91304	1
107.	Boeing Attention: Mr. Bud Nelson P.O. Box 3999, M/S 40-30 Seattle, WA 98124	1

108. IDA
Attention: Dr. Whittemore
400 Army Navy Drive
Arlington, VA 22202
109. HQ USAF
Attention: Lt. Gen. John Pustay
Office of Chief of Staff
Pentagon
Washington, DC 20330
110. Studiengruppe Luftwaffe
Sicherung Akademie der Bundeswehr
2000 Hamburg 55
Manteuffelstr. 20
Federal Republic of Germany
111. Herrn Brigadegeneral a.D. Paul-Werner Hozzel
Salierstr. 4
D7500 Karlsruhe
Federal Republic of Germany
112. 91 TFS/CC/Dow
APO 09405
New York, New York 09012
113. 78 TFS/CC/DOW
APO 09405
New York, New York 09012
114. 92 TFS/CC/DOW
APO 09755
New York, New York 09012
115. Military Attache
U.S. Embassy (Rome, Italy)
APO 90794
New York, New York 09012
116. Military Attache
U.S. Embassy (Bonn, Federal Republic of Germany)
APO 09080
New York, New York 09012
117. Military Attache
U.S. Embassy (Saudi, Arabia)
APO 09697
New York, New York 09012

118. Military Attache 1
U.S. Embassy
Attention: Air Attache
New Delhi, India

119. USAFE/DOOW 1
Attention: Maj. Lindsey
APO New York, New York 09012

120. Mr. James Simon 1
Central Intelligence Agency
Washington, DC 20505

121. Mr. Aris Pappas 1
Central Intelligence Agency
Washington, DC 20505

122. Mr. Andrew Hamilton 1
Congressional Budget Office/NSIA
4th Floor HOB, Annex #2
U.S. Congress
Washington, DC 20515

123. Mr. Pat Hillier 1
Congressional Budget Office/NSIA
4th Floor HOB, Annex #2
U.S. Congress
Washington, DC 20515

124. Dr. Dov Zakheim 1
Congressional Budget Office/NSIA
4th Floor HOB, Annex #2
Washington, DC 20515

125. Mr. John Hamre 1
Congressional Budget Office/NSIA
4th Floor HOB, Annex #2
U.S. Congress
Washington, DC 20515

126. Mr. C. Curtiss Johnson 1
T.N. Dupuy Associates, Inc.
P.O. Box 157
Dunn Loring, VA 22027

127. Col. A.J. Kettering 1
OSD/OUSDR&E
Pentagon
Washington, DC 20301

128. Mr. Steven Canby 1
10871 Springknoll Drive
Potomac, MD 20854
129. Director 1
U.S. Army Aberdeen Research & Development Center
Army Materiel Systems Analysis Agency/DRXSY
Aberdeen Proving Ground, MD 21005
130. Mr. Michael W. Iten/DRXSY-C 1
U.S. Army Materiel Systems Analysis Agency/DRXSY
Aberdeen Proving Ground, MD 21005
131. Mr. G.A. Zoller 1
U.S. Army Materiel Systems Analysis Agency/DRXSY
Aberdeen Proving Ground, MD 21005
132. Maj. J.F. Balda 1
U.S. Army Materiel Systems Analysis Agency/DRXSY
Aberdeen Proving Ground, MD 21005
133. Mr Arif R. Zaky 1
U.S. Army Materiel Systems Analysis Agency/DRXSY
Aberdeen Proving Ground, MD 21005
134. Mr. Arthur W. Garrett 1
U.S. Army Materiel Systems Analysis Agency/DRXSY
Aberdeen Proving Ground, MD 21005
135. Mr. T.A. Romanko 1
U.S. Army Material Systems Analysis Agency/DRXSY
Aberdeen Proving Ground, MD 21005
136. Mr. Stanley Eibertz 1
U.S. General Accounting Office
441 C Street, N.W.
Washington, DC 20548
137. Mr. Robert S. Dotson 1
Senate Armed Services Committee
212 Russell Senate Office Building
Washington, DC 20510
138. Mr. Dan Costello 1
OMB
New Executive Office Building
R10026
Washington, DC 20503

139. Mr. Gerald Mayefskie 1
Quest Research Corporation
6845 Elm Street
McLean, VA 22101

140. Mr. David A. Brinkman 1
U.S. General Accounting Office
441 C Street, N.W. - Room 6478
Washington, DC 20548

141. Mr. Wayne H. Coloney 1
P.O. Box 5258
Tallahassee, FL 32301

142. Lt. Gen. M.P. Casey, USAF (ret.) 5
Wayne H. Coloney Company
P.O. Box 5258
Tallahassee, FL 32301

143. Brig. General W.H. Fitch 1
Deputy Chief of Staff, R&D and Studies
USMC
Arlington Annex
Washington, DC 20380

144. Mr. Jim Erickson 1
Grumman Aerospace
BOS-05
Bethpage, NY 11714

145. Professor Andrew Cyorgy 1
Sino-Soviet Institute
George Washington University
2029 G Street, N.W.
Washington, DC 20052

146. Mr. Charles Bernard 1
Director, Land Warfare
OSD/OUSDRE
Pentagon
Washington, DC 20301

147. 162 TFG/FWS (Attention: Lt. Col. O'Connell) 5
P.O. Box 11037
Tucson, AZ 85734

148. Mr. P. Nichols 1
Ayres Corp.
P.O. Box 3090
Albany, GA 31706

- | | |
|---|---|
| 149. Defense Technical Information Center (DTIC)
Cameron Station
Alexandria, VA 22314 | 1 |
| 150. Armament Systems, Inc.
712-F N. Valley St.
Anaheim, CA 92801 | 1 |
| 151. Dean of Research, Code 012
Naval Postgraduate School
Monterey, CA 93940 | 1 |

