

AD-A095 952

AEROSPACE CORP EL SEGUNDO CA AEROPHYSICS LAB

F/S 7/4

DETECTION OF HYDRAZINE IN AIR USING ELECTRON TRANSFER IONIZATION--ETC(U)

FEB 81 P BREISACHER, P MAHADEVAN, W A HICKS

F04701-80-C-0081

UNCLASSIFIED

TR-0081(6940-01)-6

SD-TR-81-6

NL

1 of 1
AD-A095 952



END
DATE
FILMED
4-81
DTIC

LEVEL II

12

SC

AD A 095952

**Detection of Hydrazine in Air
Using Electron Transfer Ionization
Mass Spectrometry**

P. BREISACHER, P. MAHADEVAN, and W. A. HICKS
Aerophysics Laboratory ✓
Laboratory Operations
The Aerospace Corporation
El Segundo, Calif. 90245

SD TIC
ELECTE
MAR 0 5 1981
D
E

15 February 1981

Interim Report

APPROVED FOR PUBLIC RELEASE;
DISTRIBUTION UNLIMITED

Prepared for
SPACE DIVISION
AIR FORCE SYSTEMS COMMAND
Los Angeles Air Force Station
P.O. Box 92960, Worldway Postal Center
Los Angeles, California 90009

DDC FILE COPY

81 3 05 020

This interim report was submitted by The Aerospace Corporation, El Segundo, Calif. 90245, under Contract No. F04701-80-C-0081 with the Air Force Space Division, Contracts Management Office, P.O. Box 92960, Worldway Postal Center, Los Angeles, Calif. 90009. It was reviewed and approved for The Aerospace Corporation by W. R. Warren, Jr., Director, Aerophysics Laboratory. Gerhard E. Aichinger was the project officer for Mission-Oriented Investigation and Experimentation (MOIE) Programs.

This report has been reviewed by the Public Affairs Office (PAS) and is releasable to the National Technical Information Service (NTIS). At NTIS, it will be available to the general public, including foreign nations.

This technical report has been reviewed and is approved for publication. Publication of this report does not constitute Air Force approval of the report's findings or conclusions. It is published only for the exchange and stimulation of ideas.

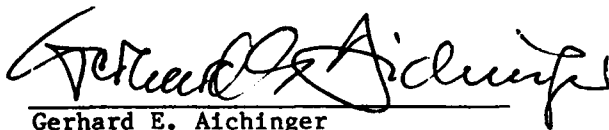

Gerhard E. Aichinger
Project Officer

FOR THE COMMANDER

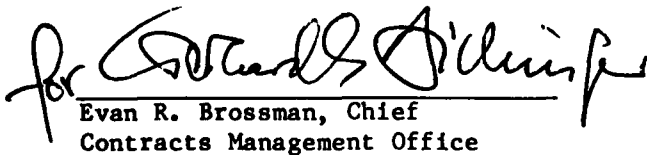

for Evan R. Brossman, Chief
Contracts Management Office

UNCLASSIFIED

SECURITY CLASSIFICATION OF THIS PAGE (When Data Entered)

19 REPORT DOCUMENTATION PAGE		READ INSTRUCTIONS BEFORE COMPLETING FORM
1. REPORT NUMBER 18 SD-TR-81-6	2. GOVT ACCESSION NO. AD A095952	3. RECIPIENT'S CATALOG NUMBER
4. TITLE (and Subtitle) 6 DETECTION OF HYDRAZINE IN AIR USING ELECTRON TRANSFER IONIZATION MASS SPECTROMETRY.	5. TYPE OF REPORT & PERIOD COVERED 19 Interim rept.	
7. AUTHOR(s) 10 P. Breisacher, P. Mahadevan, W. A. Hicks	14 PERFORMING ORG. REPORT NUMBER TR-0061(6940-01)-6	15 CONTRACT OR GRANT NUMBER(s) 15 E04701-80-C-0081
9. PERFORMING ORGANIZATION NAME AND ADDRESS The Aerospace Corporation El Segundo, Calif. 90245	10. PROGRAM ELEMENT, PROJECT, TASK AREA & WORK UNIT NUMBERS	
11. CONTROLLING OFFICE NAME AND ADDRESS Space Division Air Force Systems Command Los Angeles Air Force Station Los Angeles, Calif. 90009	12. REPORT DATE 11 15 Feb 1981	13. NUMBER OF PAGES 20
14. MONITORING AGENCY NAME & ADDRESS (if different from Controlling Office) 12 24	15. SECURITY CLASS. (of this report) Unclassified	15a. DECLASSIFICATION/DOWNGRADING SCHEDULE
16. DISTRIBUTION STATEMENT (of this Report) Approved for public release; distribution unlimited.		
17. DISTRIBUTION STATEMENT (of the abstract entered in Block 20, if different from Report)		
18. SUPPLEMENTARY NOTES		
19. KEY WORDS (Continue on reverse side if necessary and identify by block number) Analysis in Air Electron Transfer Ionization Mass Spectrometry Hydrazine (H(+))		
20. ABSTRACT (Continue on reverse side if necessary and identify by block number) A simple direct analytical method for the detection of hydrazine (N ₂ H ₄) in air is described. The N ₂ H ₄ is ionized in electron transfer collisions with a low kinetic energy projectile ion (H ⁺) under well-controlled conditions in a collision chamber. A single product ion is formed. Interference by background air is not observed. The product ion is detected using a quadrupole mass spectrometer. Preliminary estimates of the detection sensitivity of the present instrument configuration for N ₂ H ₄ are discussed.		

00 FORM 1473 (FACSIMILE)

409367

UNCLASSIFIED SECURITY CLASSIFICATION OF THIS PAGE (When Data Entered)

CONTENTS

I. INTRODUCTION..... 5

II. BACKGROUND..... 7

III. TECHNICAL APPROACH..... 9

IV. APPARATUS..... 11

V. PROCEDURE..... 13

VI. RESULTS AND DISCUSSION..... 15

VII. CONCLUSIONS AND RECOMMENDATIONS FOR FUTURE WORK..... 21

REFERENCES..... 23

Accession For	
NTIS GRA&I	<input checked="" type="checkbox"/>
DTIC TAB	<input type="checkbox"/>
Unannounced	<input type="checkbox"/>
Justification	
Distribution/	
Availability Codes	
Dist	Avail and/or Special
A	

FIGURES

1.	Electron Transfer Ionization Mass Spectrometer System.....	12
2.	Electron Impact Positive Ion Mass Spectrum of Hydrazine.....	16
3.	Electron Transfer Ionization Positive Ion Mass Spectrum of Hydrazine.....	18
4.	Apparatus for the Preparation of Hydrazine Mixtures in Air.....	19

I. INTRODUCTION

The increased use of hydrazine (N_2H_4) in both space and military applications has resulted in a requirement for more careful monitoring of work areas to prevent exposures of individuals to what is now suspected to be a potentially carcinogenic or tumorigenic agent. Threshold limit values for N_2H_4 have recently been established at 0.1 ppm by the Office of Safety and Health Administration (OSHA). Reliable, continuous monitoring of storage areas is required to detect the presence of N_2H_4 and monomethyl hydrazine (MMH) fuel leaks as well as very low level concentrations of hydrazine in the environment. Many instrumental techniques have been evaluated¹ in the past for low level N_2H_4 detection. Some are only semicontinuous (e.g., gas chromatography), whereas others are continuous but involve the chemical conversion of N_2H_4 to another compound that is detectable by the particular analytical scheme being used (e.g., chemiluminescence).

The ever-increasing need for the unambiguous detection of N_2H_4 in such environments as launch facilities and work areas for the Titan and Space Shuttle, military aircraft hangars, and service facilities demands the deployment of large numbers of monitoring instruments. The individual cost of each unit must, therefore, be considered when evaluating each technique for possible field application. A further criterion is portability, since in many applications the locale requires self-containment of the instrumentation.

Electron transfer ionization mass spectrometry (ETIMS) is suggested as a potentially useful analytical approach for leak detection and low concentration monitoring of N_2H_4 in the environment.

¹R. A. Saunders and J. T. Larkins, Detection and Monitoring of Hydrazine, Monomethylhydrazine and Their Decomposition Products, NRL Report No. 3313, Naval Research Laboratory, Washington, D.C. (June 1976).

II. BACKGROUND

A brief review of current monitoring techniques for N_2H_4 would be quite useful for a proper assessment of the simplicity and merits of the electron transfer ionization analytical approach outlined in this report.

Currently, three analytical techniques are considered as strong candidates for the analysis of N_2H_4 at the threshold limit value (TLV). Chemiluminescence is based upon the analysis of NO produced by the catalytic oxidation of N_2H_4 . The sequential reactions are:



where the asterisk represents an excited NO_2 molecule that decays with the emission of a photon



The NO is detected by monitoring the level of excited NO_2 present after NO has been reacted completely with O_3 , Eq. (2). The catalyst chosen is specific only to the formation of NO from N_2H_4 . No other oxides of nitrogen are produced. The sensitivity of such equipment is adequate, but the technique fails to distinguish NO present in the atmosphere from that produced by N_2H_4 oxidation. Correction can be made for this failing by bypassing the catalytic converter. The atmospheric contribution of NO is then subtracted from the total NO detected from oxidized N_2H_4 and ambient air. If NO_2 is also present, no correction can be made, however, for this oxide. This results in an erroneously high value for N_2H_4 concentration.

Another prime candidate for N_2H_4 detection is a technique that utilizes the electrochemical oxidation and reduction of NO and NO_2 .² Again, the N_2H_4 must first be catalytically converted to NO. The NO_2 is also converted to NO but can be independently measured without conversion in a separate electrochemical cell. The ambient NO can be measured directly by bypassing the N_2H_4 catalytic converter. If N_2H_4 is to be measured in the presence of N_2O_4 oxidizer, some problems might arise in situations where very low concentrations of N_2H_4 are to be detected. The difference between the total signal ($NO + NO_2 + N_2H_4$) and N_2H_4 may be too small to be measured with confidence. Ordinarily, this problem does not exist and, therefore, this technique is easily the most sensitive and accurate method presently available for N_2H_4 detection. Cost, portability, and reliability appear reasonable, although proper maintenance and careful calibration of this delicate equipment is necessary during periods of nonuse in order to qualify it as a ready standby detection system.

A third candidate for the continuous analysis of N_2H_4 in air is a colorimetric method based on phosphomolybdic acid. The latter is impregnated onto a paper strip mounted on a cassette reel. The strip is moved past an aperture that exposes half of the tape to ambient air. When the color is developed, the tape is passed through a second aperture for measurement with the use of a spectrophotometric detector. Continuous operation for up to 1 week can be achieved. Presently, this method is being actively evaluated with respect to sensitivity and problems associated with possible lack of sensitivity.

²R. A. Saunders et al., Evaluation of an Electrochemical Detector for Trace Concentrations of Hydrazine Compounds in Air, NRL Report No. 8199, Naval Research Laboratory, Washington, D.C. (April 1978).

Another prime candidate for N_2H_4 detection is a technique that utilizes the electrochemical oxidation and reduction of NO and NO_2 .² Again, the N_2H_4 must first be catalytically converted to NO. The NO_2 is also converted to NO but can be independently measured without conversion in a separate electrochemical cell. The ambient NO can be measured directly by bypassing the N_2H_4 catalytic converter. If N_2H_4 is to be measured in the presence of N_2O_4 oxidizer, some problems might arise in situations where very low concentrations of N_2H_4 are to be detected. The difference between the total signal ($NO + NO_2 + N_2H_4$) and N_2H_4 may be too small to be measured with confidence. Ordinarily, this problem does not exist and, therefore, this technique is easily the most sensitive and accurate method presently available for N_2H_4 detection. Cost, portability, and reliability appear reasonable, although proper maintenance and careful calibration of this delicate equipment is necessary during periods of nonuse in order to qualify it as a ready standby detection system.

A third candidate for the continuous analysis of N_2H_4 in air is a colorimetric method based on phosphomolybdic acid. The latter is impregnated onto a paper strip mounted on a cassette reel. The strip is moved past an aperture that exposes half of the tape to ambient air. When the color is developed, the tape is passed through a second aperture for measurement with the use of a spectrophotometric detector. Continuous operation for up to 1 week can be achieved. Presently, this method is being actively evaluated with respect to sensitivity and problems associated with possible lack of sensitivity.

²R. A. Saunders et al., Evaluation of an Electrochemical Detector for Trace Concentrations of Hydrazine Compounds in Air, NRL Report No. 8199, Naval Research Laboratory, Washington, D.C. (April 1978).

III. TECHNICAL APPROACH

The method under investigation in this program is potentially simpler, less ambiguous, and less costly to operate than any of the above three candidates. With this technique, N_2H_4 is analyzed mass spectrometrically without conversion to an oxide or other derivative. Interferences from NO , NO_2 , and O_2 are absent. Previous attempts to use conventional mass spectrometry have been rejected primarily because of high cost, nonportability, and interferences of background species or fragments at the mass peaks where the primary ions of N_2H_4 are produced under normal electron impact. These interference problems are usually solved by the ETIMS technique of selectively producing only a single ion for each species present. Charge exchange collisions between a primary ion (protons from H_2O or H_2) and N_2H_4 occur in a collision chamber under controlled conditions. The signal-to-noise ratio is considerably greater than that obtained with chemical ionization (CI) or electron impact (EI). The kinetic energy of the projectile ion can be adjusted to yield the simplest single ion spectrum of the target species. Maximum sensitivities of detection are achieved by optimization of the specific orientation of the collision chamber with respect to the signal extraction orifice of the product mass spectrometer. In the following sections the specific experimental layout, procedural steps, and preliminary results obtained in the existing ETIMS laboratory system are described.

IV. APPARATUS

A detailed description of the ETIMS apparatus is given elsewhere.³ Some of the relevant details are summarized below.

The apparatus (Fig. 1) consists of an ion source from which positive or negative ions can be extracted, a projectile ion magnetic sector mass spectrometer, conventional ion beam focusing devices and a collision region where the projectile ions interact with the sample species, an electrode assembly for ion extraction from the collision volume, and a quadrupole mass spectrometer for product analysis. Since the product ions are extracted at right angles to the projectile ion beam axis, the latter ions are not superposed on the product mass spectrum. This feature contrasts sharply with the CI approach. With the present apparatus, the primary ion mass and kinetic energy ranges extend to 200 amu and 1 keV, respectively. A variety of projectile ions can be extracted from moist air. In this particular study, H^+ is obtained from H_2O in the air. This feature eliminates the need to carry bottled source gases for a portable field detector being designed for N_2H_4 detection. In this positive ion mode, the ion kinetic energy can be reduced to a few electron volts only with adequate ion beam intensity in the collision region. The ion kinetic energy is typically under 50 eV. The projectile ion current, monitored continuously using a Faraday cup electrode in the collision chamber, varies from a maximum of 1×10^{-7} A to about 5×10^{-9} A. The ion beam path from the source to the collision region is about 50 cm. The collision chamber is maintained at a pressure of approximately 5×10^{-5} Torr.

The ratio of sample to background pressure in the ETIMS chamber is about 8 compared with 10^{-3} for the CI system.⁴ The ETIMS approach thus improves the signal-to-noise ratio by a factor well in excess of 1000.

³P. Mahadevan and P. Breisacher, Electron Transfer Ionization Mass Spectrometry of Selected Molecular Species, ATR-78(8112)-1, The Aerospace Corp., El Segundo, Calif. (June 1978).

⁴A. L. Burlingame, Topics in Organic Mass Spectrometry, Vol. 8, Wiley Interscience, New York (1970), p. 75.

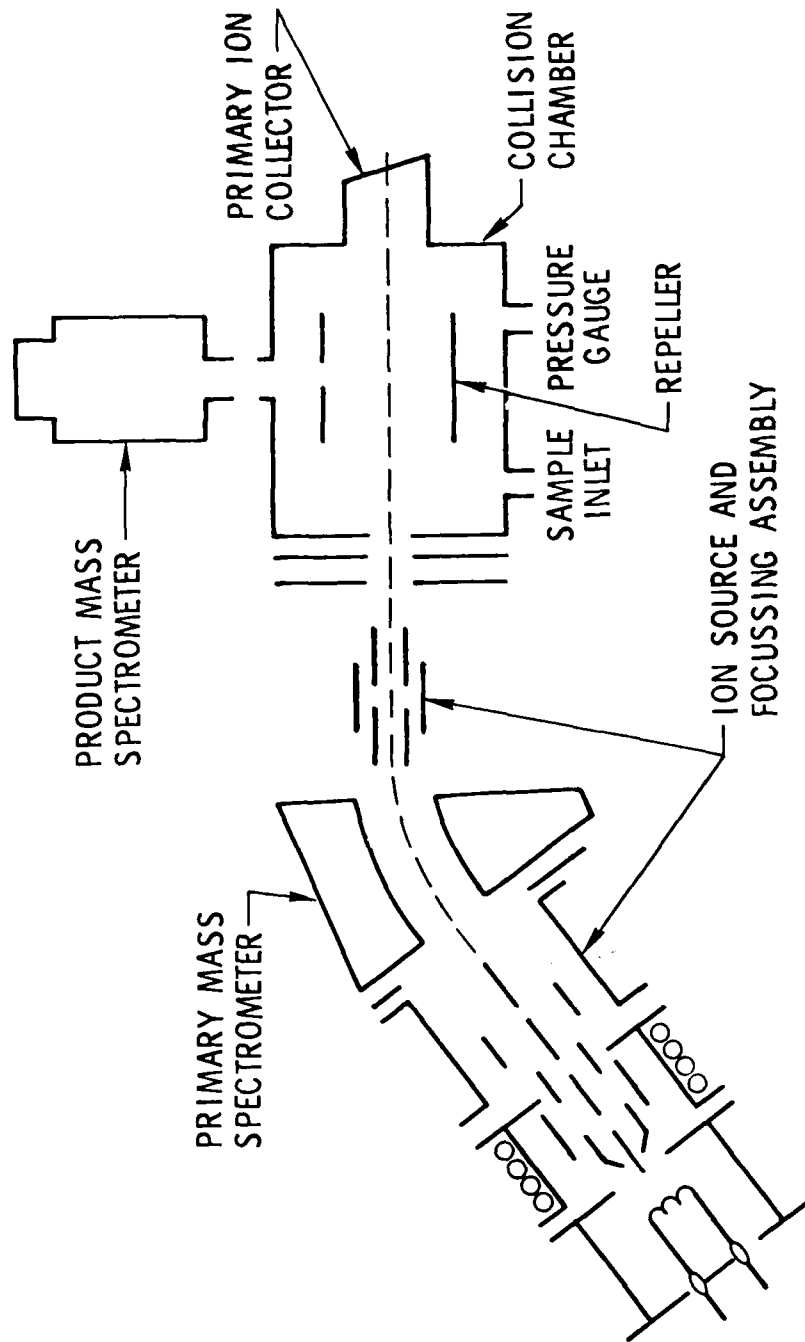

Fig. 1. Electron Transfer Ionization Mass Spectrometer System

V. PROCEDURE

Reagent grade anhydrous N_2H_4 is transferred to a stainless steel sample vessel, evacuated for a short time, and cooled to -78°C with the use of a cryogenic bath before sustained pumping. Moist room air is leaked into the projectile ion source until the background pressure rises to about 1×10^{-5} Torr. The distilled N_2H_4 is then introduced into the collision chamber to a pressure of $\sim 4 \times 10^{-5}$ Torr at room temperature. Adjustments are made to optimize the intensity of the N_2H_4 signal at the detector (quadrupole mass spectrometer).

Passivation of the gas handling system and the collision chamber with N_2H_4 appears to ensure stable reproducible operation of the system. The effect of surface passivation on the response time of the instrument for low concentrations of N_2H_4 in air is discussed later in this report.

VI. RESULTS AND DISCUSSION

The principal mass peak of N_2H_4 is either 32 or 31 depending upon the source of H^+ projectile ions.⁵ When H_2 is used as the H^+ source, amu 32 is the main peak. When H_2O in air is used (as is planned in future development), amu 31 is the principal peak (Fig. 2b). It is also noted that the secondary smaller peaks (amu 31 in Fig. 2a and amu 32 in Fig. 2b) decrease disproportionately faster than the respective principal peaks as the pressure is lowered. Source pressure can, therefore, be controlled in an analyzer to yield only single ion peak spectra.

A possible explanation for the differences noted using H_2 and H_2O as H^+ sources is the nature of the form of N_2H_4 that is actually subjected to charge transfer. With the use of H_2 as the source of H^+ , the reactions occurring are

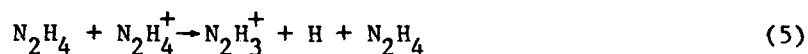

As the pressure is lowered, the reaction shown by Eq. (5) becomes minimal. With the use of H_2O as the H^+ source, the N_2H_4 can form the monohydrate at the background H_2O concentrations. The principal molecule actually subjected to charge transfer is, therefore, $N_2H_4 \cdot H_2O$

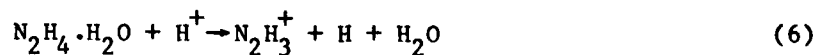

⁵P. Breisacher, P. Mahadevan, and W. A. Hicks, Paper presented 27th Annual Meeting, American Society for Mass Spectrometry, Seattle, Washington, June 1979.

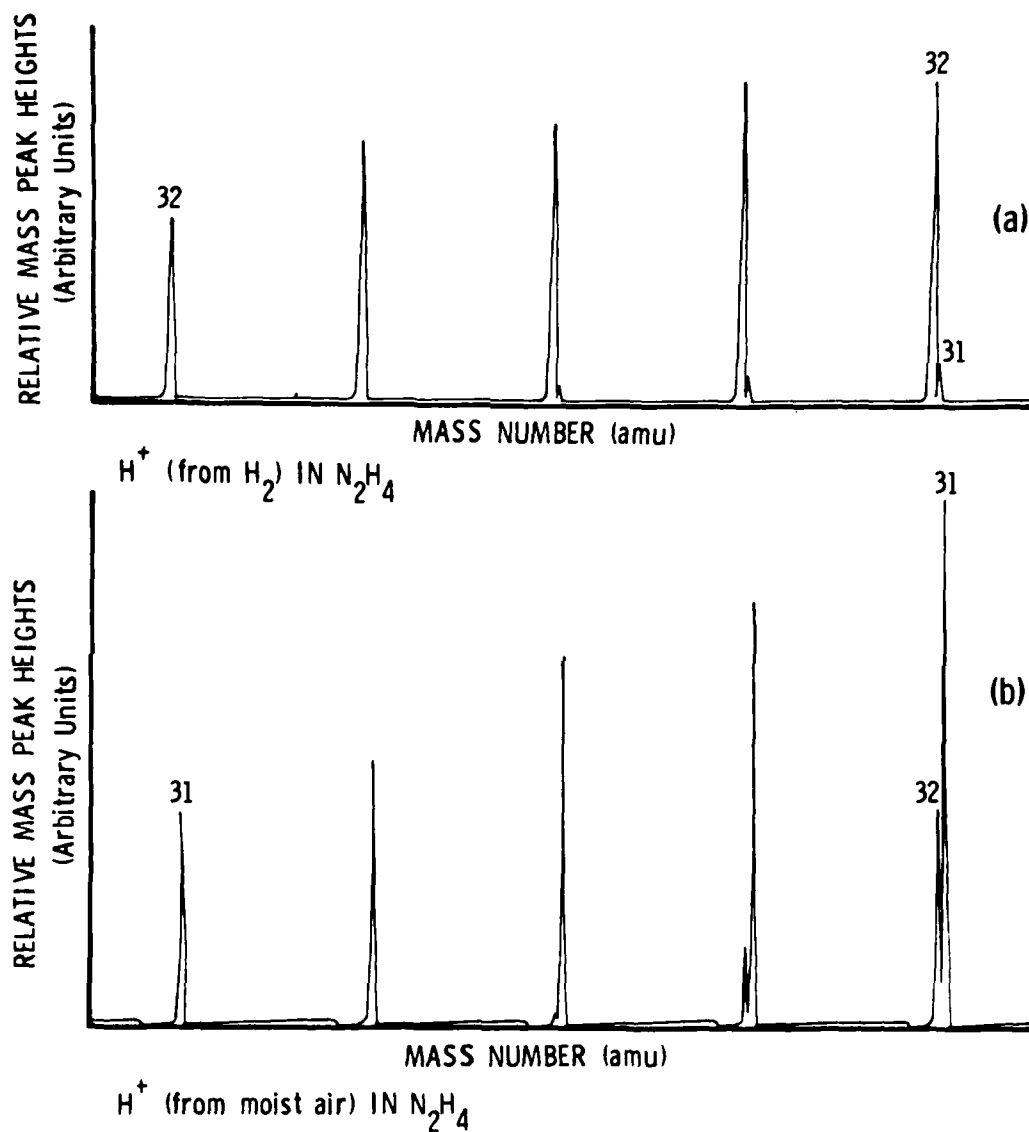

Fig. 2. Electron Transfer Ionization Positive Ion Mass Spectrum of Hydrazine. (a) ETI mass spectrum of N_2H_4 using H^+ from H_2 as projectile ions, as a function of increasing N_2H_4 pressure. (b) ETI mass spectrum of N_2H_4 using H^+ from moist air as projectile ions, as a function of increasing N_2H_4 pressure

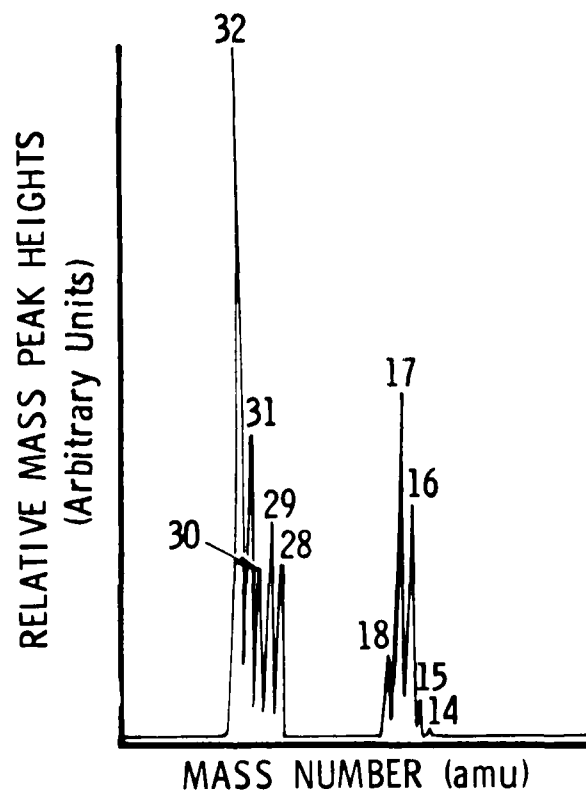

Fig. 3. Electron Impact Positive Ion Mass Spectrum of Hydrazine

The conventional EI spectrum of N_2H_4 is shown in Fig. 3. This is in qualitative agreement with American Petroleum Institute (API)⁶ data.

Unequivocal identification and monitoring of N_2H_4 fuels at the launch facilities and work areas of the Titan and Space Shuttle are quite feasible with the ETMS system in its present form.

The obvious environmental interference for the mass spectrometrical detection of N_2H_4 is molecular oxygen from the atmosphere. We have shown in the preceding section (Fig. 2b) that the 32 amu mass peak from N_2H_4 is a secondary ion peak, much smaller in magnitude than the principal ion $N_2H_3^+$, provided the gas mixture being analyzed contains residual water vapor. This is invariably the case for environmental monitoring. Interferences from atmosphere oxygen, thus, would be of apparently no consequence for the ETMS approach outlined here.

The detection limit for N_2H_4 in air is specified by the presence of a measurable signal at $m/e = 31$. This criterion is based on the current configuration of the ETMS apparatus. Mass fragment 31 ($N_2H_3^+$) is produced in the reaction shown by Eq. (6) as discussed earlier. The experimental detection limit is probably too high because of N_2H_4 loss to the walls of the gas handling system and collision chamber. Surface interaction can involve absorption or decomposition.

Mixtures of N_2H_4 in air were made by successively diluting pure N_2H_4 vapor in a small stainless steel cylinder. The latter is coupled closely to the gas inlet valve of the ETMS apparatus. The bottle is approximately 24 in. from the collision chamber. The apparatus for the preparation of these mixtures is shown in Fig. 4. Output of the mass spectrometer signal is continuously recorded on a strip chart recorder.

An instrument response delay time of several minutes occurs with mixtures of less than 0.5% N_2H_4 in air. At even lower concentrations, the delay time

⁶Index of Mass Spectral Data, American Petroleum Institute, Research Project 44, NBS, Washington, D.C., 1944.

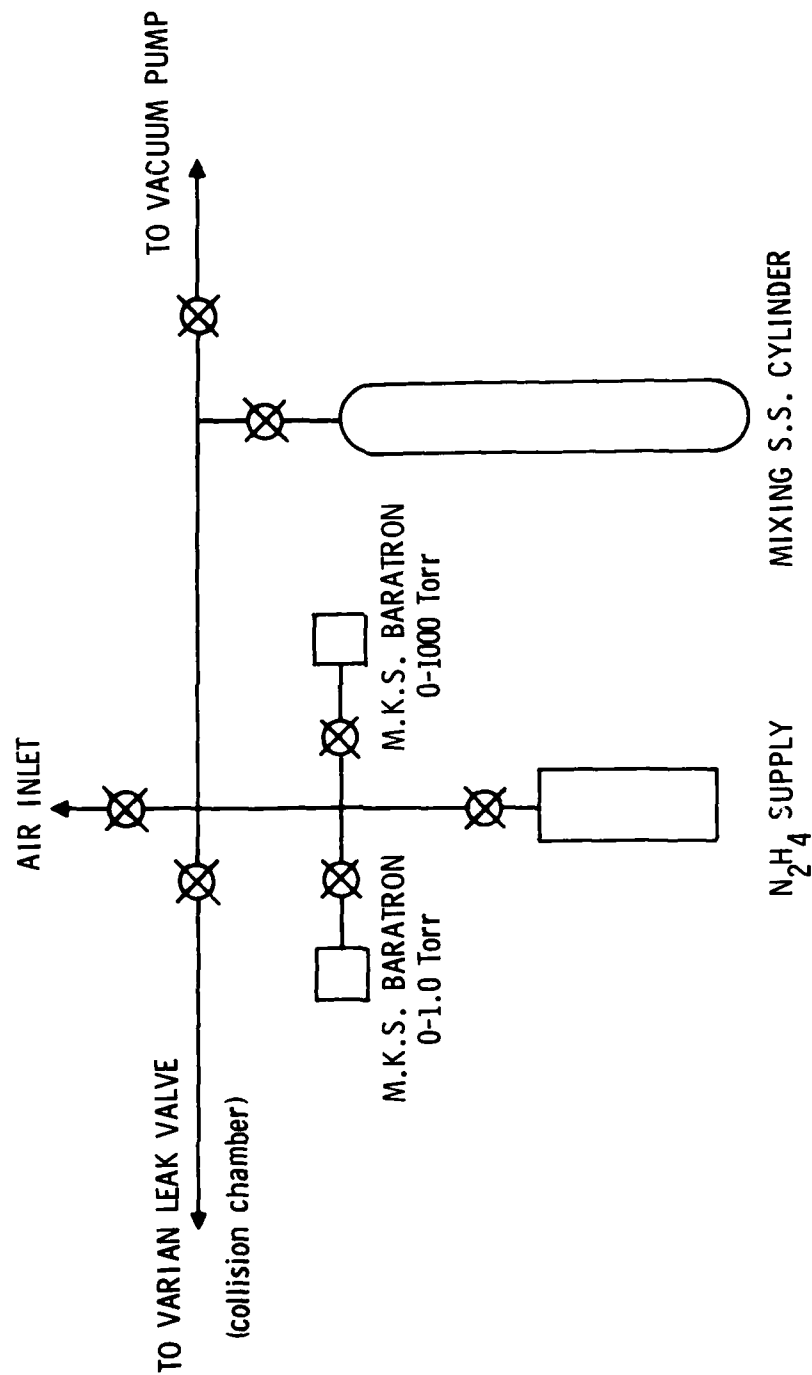

Fig. 4. Apparatus for the Preparation of Hydrazine Mixtures in Air

increases further. This is apparently due to the initial loss of N_2H_4 to the walls. The presence of the adsorbed gas on the walls results in long-term retention of signal after pumpout. This can be rapidly eliminated by the heating of the affected surfaces. Pressurization with N_2 also accelerates the desorption process.

The lowest concentration of N_2H_4 detected to date is 5 ppm. The response time is about 20 min. Equilibrium conditions are achieved in this period to justify the claim of this detection limit for the gas phase concentration of N_2H_4 in the mixture. The sensitivity of the instrument with electron multiplication calculated from the available signal at this concentration level is roughly equal to 10^{-11} A/Torr.

Preliminary measurements with the alkylated derivatives of N_2H_4 , MMH, and unsymmetrical dimethyl hydrazine (UDMH), respectively, with the use of the ETMS approach indicate a useful monitoring role for the system for these molecules as well. By optimization of the projectile ion kinetic energy and target gas pressure, single peak mass spectra corresponding to MMH and UDMH, respectively, have been recorded.

VII. CONCLUSIONS AND RECOMMENDATIONS FOR FUTURE WORK

Using the ETIMS apparatus in its present configuration, we have monitored the concentrations of N_2H_4 in air down to 5 ppm. By the use of moist air as the source gas in the ion source from which the projectile ions (H^+) are extracted, the need is eliminated for a bottled gas for this purpose in a portable field instrument. This approach is unique since the N_2H_4 is analyzed without conversion to an oxide or other derivative.

The ETIMS technique can also be used for the detection of the alkylated derivatives MMH and UDMH as well as the oxidation products NO and NH_3 .

Prior to the design of a more compact, self-contained portable ETIMS system for N_2H_4 detection, several important and useful minor modifications should be made to the existing apparatus for the improvement of its operating characteristics such as stability and sensitivity. The following recommendations are in this category.

1. Design a physically compact collision cell in place of the large one currently in use (3 in. diameter, 6 in. length). Considerable improvement in response time at low concentrations should result from this change since the total surface area exposed to the sample is appreciably reduced.
2. Investigate the effect of unanalyzed composite ion beams from H_2 or moist air in the ion source. If interference from ions other than H^+ is minimal, ion beam intensity at low energy can be increased appreciably under the same operating conditions for the ion source, thus improving the lower detection limit of the instrument.
3. Operate the electron multiplier detector of the mass spectrometer in the pulse counting mode for concentrations of N_2H_4 in air of a few parts per million and lower.

LABORATORY OPERATIONS

The Laboratory Operations of The Aerospace Corporation is conducting experimental and theoretical investigations necessary for the evaluation and application of scientific advances to new military concepts and systems. Versatility and flexibility have been developed to a high degree by the laboratory personnel in dealing with the many problems encountered in the Nation's rapidly developing space systems. Expertise in the latest scientific developments is vital to the accomplishment of tasks related to these problems. The laboratories that contribute to this research are:

Aerophysics Laboratory: Aerodynamics; fluid dynamics; plasmadynamics; chemical kinetics; engineering mechanics; flight dynamics; heat transfer; high-power gas lasers, continuous and pulsed, IR, visible, UV; laser physics; laser resonator optics; laser effects and countermeasures.

Chemistry and Physics Laboratory: Atmospheric reactions and optical backgrounds; radiative transfer and atmospheric transmission; thermal and state-specific reaction rates in rocket plumes; chemical thermodynamics and propulsion chemistry; laser isotope separation; chemistry and physics of particles; space environmental and contamination effects on spacecraft materials; lubrication; surface chemistry of insulators and conductors; cathode materials; sensor materials and sensor optics; applied laser spectroscopy; atomic frequency standards; pollution and toxic materials monitoring.

Electronics Research Laboratory: Electromagnetic theory and propagation phenomena; microwave and semiconductor devices and integrated circuits; quantum electronics, lasers, and electro-optics; communication sciences, applied electronics, superconducting and electronic device physics; millimeter-wave and far-infrared technology.

Materials Sciences Laboratory: Development of new materials; composite materials; graphite and ceramics; polymeric materials; weapons effects and hardened materials; materials for electronic devices; dimensionally stable materials; chemical and structural analyses; stress corrosion; fatigue of metals.

Space Sciences Laboratory: Atmospheric and ionospheric physics, radiation from the atmosphere, density and composition of the atmosphere, aurorae and airglow; magnetospheric physics, cosmic rays, generation and propagation of plasma waves in the magnetosphere; solar physics, x-ray astronomy; the effects of nuclear explosions, magnetic storms, and solar activity on the earth's atmosphere, ionosphere, and magnetosphere; the effects of optical, electromagnetic, and particulate radiations in space on space systems.

DATE
ILME