

AD-A095 980

MITRE CORP BEDFORD MA
TWELVE-CHANNEL FIBER OPTIC VOICE MULTIPLEXER.(U)
JAN 81 A P PEARDON

F/G 17/2

F19628-80-C-0001

UNCLASSIFIED

WP-22582

RADC-TR-80-392

NL

1 of 1
2045 11

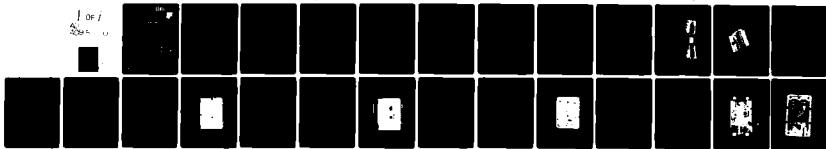

END
DATE
FILMED
4 2 79
DTIC

12

LEVEL

II

AD A 095930

RADC-TR-80-392

Interim Report

January 1981



TWELVE-CHANNEL FIBER OPTIC VOICE MULTIPLEXER

The MITRE Corporation

A. P. Peardon

APPROVED FOR PUBLIC RELEASE; DISTRIBUTION UNLIMITED

DTIC
ELECTE
S MAR 4 1981 D
B

ROME AIR DEVELOPMENT CENTER
Air Force Systems Command
Griffiss Air Force Base, New York 13441

DBG FILE COPY

81 3 3 058

This report has been reviewed by the RADC Public Affairs Office (PA) and is releasable to the National Technical Information Service (NTIS). At NTIS it will be releasable to the general public, including foreign nations.

RADC-TR-80-392 has been reviewed and is approved for publication.

APPROVED:

Thomas A. Ross

THOMAS A. ROSS
Project Engineer

APPROVED:

Fred I. Diamond

FRED I. DIAMOND, Technical Director
Communications and Control Division

FOR THE COMMANDER:

John P. Huss

JOHN P. HUSS
Acting Chief, Plans Office

If your address has changed or if you wish to be removed from the RADC mailing list, or if the addressee is no longer employed by your organization, please notify RADC (DCCT) Griffiss AFB NY 13441. This will assist us in maintaining a current mailing list.

Do not return this copy. Retain or destroy.

UNCLASSIFIED

SECURITY CLASSIFICATION OF THIS PAGE (When Data Entered)

REPORT DOCUMENTATION PAGE		READ INSTRUCTIONS BEFORE COMPLETING FORM
1. REPORT NUMBER RADC-TR-80-392	2. GOVT ACCESSION NO. AD-A095480	3. RECIPIENT'S CATALOG NUMBER 9
4. TITLE (and Subtitle) TWELVE-CHANNEL FIBER OPTIC VOICE MULTIPLEXER	5. TYPE OF REPORT & PERIOD COVERED Interim Report	
7. AUTHOR(s) A. P. Peardon	6. PERFORMING ORG. REPORT NUMBER WP-22582	8. CONTRACT OR GRANT NUMBER(s) F19628-80-C-0001
9. PERFORMING ORGANIZATION NAME AND ADDRESS The MITRE Corporation Bedford MA 01730	10. PROGRAM ELEMENT, PROJECT, TASK AREA & WORK UNIT NUMBERS 62702F 45192141	
11. CONTROLLING OFFICE NAME AND ADDRESS Rome Air Development Center (DCCT) Griffiss AFB NY 13441	12. REPORT DATE January 1981	13. NUMBER OF PAGES 28
14. MONITORING AGENCY NAME & ADDRESS (if different from Controlling Office) Same	15. SECURITY CLASS. (of this report) UNCLASSIFIED	
16. DISTRIBUTION STATEMENT (of this Report) Approved for public release; distribution unlimited.		
17. DISTRIBUTION STATEMENT (of the abstract entered in Block 20, if different from Report) Same		
18. SUPPLEMENTARY NOTES RADC Project Engineer: Thomas A. Ross (RADC/DCCT)		
19. KEY WORDS (Continue on reverse side if necessary and identify by block number) Fiber Optic Multiplexer Radio Remoting		
20. ABSTRACT (Continue on reverse side if necessary and identify by block number) This paper describes a 12-channel fiber optic remoting system used to remote TACS radios such as the MRC 107/108 Jeep Radio, AN/TSC-60 HF Radio, AN/TRC-87 UHF Radio and AN/TRC-97 Tropo Radio. This system employs two 12-channel FM analog multiplexers (with push to talk capability), a fiber optic laser transmitter, a PIN photodetector receiver and a two fiber cable.		

DD FORM 1473 1 JAN 73 EDITION OF 1 NOV 65 IS OBSOLETE

UNCLASSIFIED

SECURITY CLASSIFICATION OF THIS PAGE (When Data Entered)

235151

JTC

UNCLASSIFIED

SECURITY CLASSIFICATION OF THIS PAGE (When Data Entered)

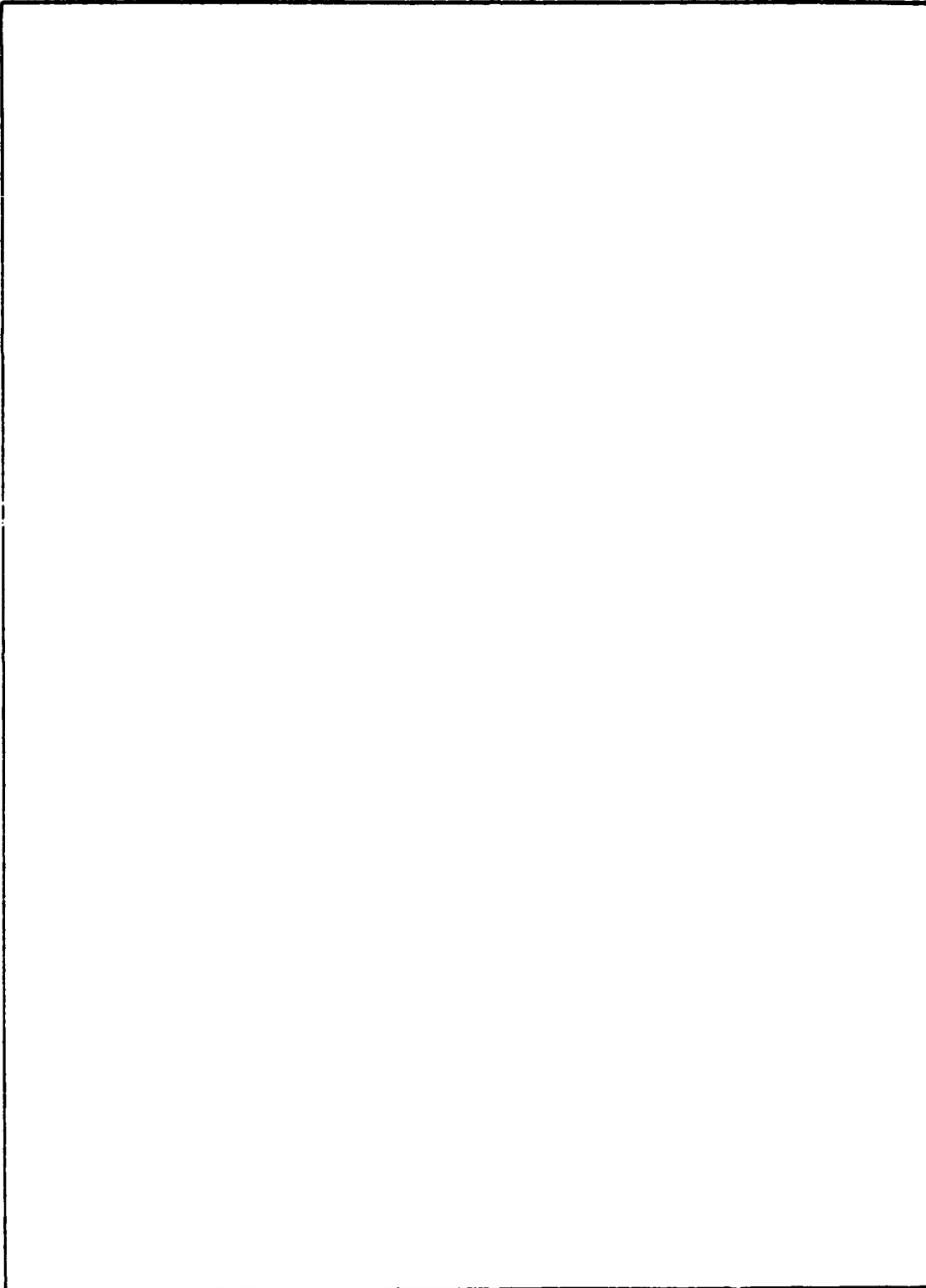

UNCLASSIFIED

SECURITY CLASSIFICATION OF THIS PAGE (When Data Entered)

PREFACE

The information presented herein has been checked and is believed to be accurate and reliable. However, The MITRE Corporation reserves the right to make changes, additions, and revisions, as need be, to ensure the accuracy and consistency of the material. In addition, no material contained herein may be duplicated, reproduced, or transcribed without the express permission of The MITRE Corporation and its sponsors, the U.S. Air Force, RADC (Rome Air Development Center). Further, no licenses are granted for the express use of the material for purposes that otherwise infringe upon or violate the patent rights of MITRE and the U.S. Air Force.

Availability Codes	
	<input checked="" type="checkbox"/>
	<input type="checkbox"/>
	<input type="checkbox"/>
Dist	
Availability Codes	
Dist	Avail and/or Special
A	

TABLE OF CONTENTS

<u>Section</u>		<u>Page</u>
	LIST OF ILLUSTRATIONS	vi
	LIST OF TABLES	vi
1	INTRODUCTION	1
2	PHYSICAL DESCRIPTION	2
3	ELECTRICAL CHARACTERISTICS	5
4	ELECTRICAL DESCRIPTION	7
	4.1 Transmit Channels	7
	4.2 Summing Amplifier	10
	4.3 FM Receiver Modules	13
	4.4 Patch Panel	16
	4.5 Channel RF Carrier Assignments	16
	4.6 Optical Transmitters and Receivers	17
	GLOSSARY	21
	DISTRIBUTION LIST	23

LIST OF ILLUSTRATIONS

<u>Figure</u>		<u>Page</u>
1	12-Channel Fiber Optic Voice Multiplexer	3
2	12-Channel Multiplexer - Case Removed	4
3	Schematic of Transmitter Circuits	8
4	Transmitter Printed Circuit Board	9
5	Schematic of Summing Amplifier Circuits	11
6	Summing Amplifier Printed Circuit Board	12
7	Schematic of Receiver Circuits	14
8	Receiver Printed Circuit Board	15
9	Optical Transmitter Module	18
10	Optical Receiver Module	19

LIST OF TABLES

<u>Table</u>		<u>Page</u>
1	Electrical Characteristics	6

SECTION 1

INTRODUCTION

Recently there has been a growing concern in TACS (tactical air control system) regarding the vulnerability of active emitters such as radars, G/A (ground-to-air) radios, and microwave systems to electromagnetic seeking missiles, particularly when these devices are collocated with operation centers such as the CRP/CRC (control and reporting post/center) and FACP (forward air control post). In consequence, the current trend is to remote the emitting devices to increase the survivability of personnel and equipment.

This paper describes a full-duplex 12-channel analog FM voice multiplexer/demultiplexer, including selectable push-to-talk capability on each of the 12 channels. Each multiplexer/demultiplexer includes an optical transmitter/receiver, which is interconnected via several kilometers of ruggedized, lightweight, dual-fiber optical cable. In the current TACS, radios such as the AN/TSC-60, AN/TRC-87, MRC-107/108, and AN/TRC-97 are interconnected via several standard 26-pair cables which are heavy, bulky, and limit the distance of remoting. The 12-channel fiber optic remoting system described herein permits several of these radios to be remoted simultaneously at distances of several kilometers tremendous reduction in cable weight and bulk.

It is planned to field test the system at the 102nd Tactical Squadron, North Smithfield, Rhode Island, during October - November, 1979.

SECTION 2

PHYSICAL DESCRIPTION (See Figures 1 and 2)

Each terminal of the system is housed in a splashproof case measuring 10 inches high, 19 inches wide, and 18 inches deep and weighing approximately 35 pounds. Front and rear captive covers protect the equipment during transport and storage. Drawer slides are provided so that the equipment chassis can be withdrawn from the case for servicing. All printed circuit cards are accessible from the front of the unit by merely dropping the hinged front panel. A standard 26-pair cable is used to interconnect the units to existing TACS shelters or junction boxes.

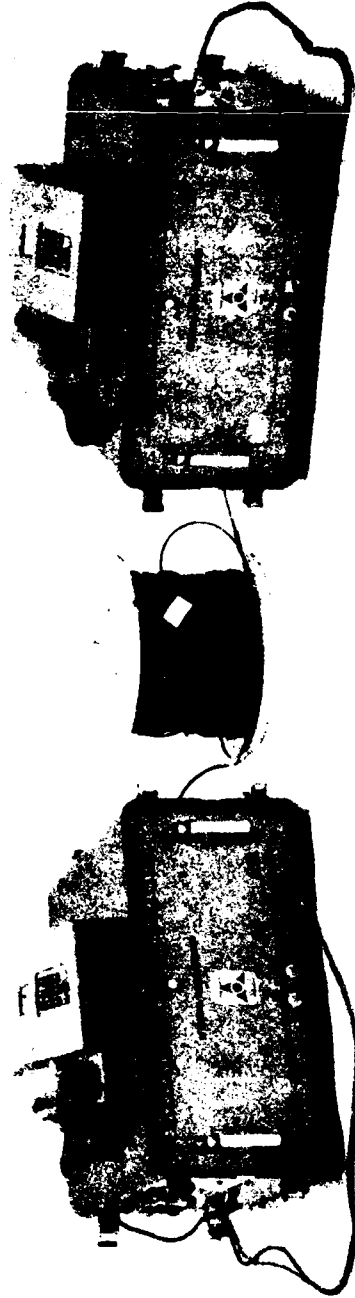

Figure 1. 12-Channel Fiber Optic Voice Multiplexer

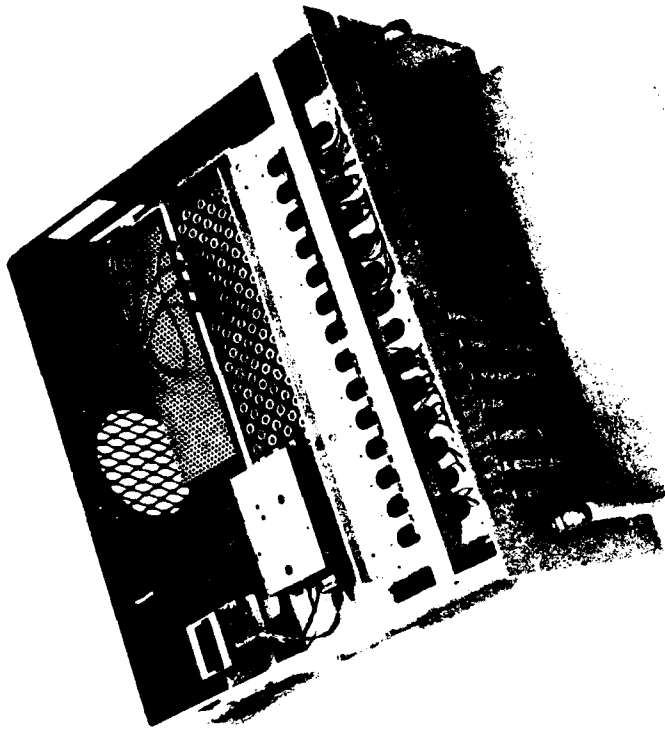

Figure 2. 12-Channel Multiplexer - Case Removed

SECTION 3

ELECTRICAL CHARACTERISTICS

The electrical characteristics of the 12-channel fiber optic voice multiplexer/demultiplexer are summarized in table 1.

TABLE 1
ELECTRICAL CHARACTERISTICS

Multiplexer

Number of channels	12
Number of push-to-talk channels	12 (selectable)
Type of modulation	Analog FM
Deviation	20 to 50 kHz
Input/output impedance	600 ohms balanced
Input levels	-30 to +5 dBm
Output levels (adjustable)	-30 to +5 dBm
Idle channel noise	-48 to 60 dBm
Channel bandwidth	300 Hz to 10 kHz
Crosstalk (adjacent channel)	>45 dB
Power consumption	10 W max

Optics

Transmitter

Optical power	800 microwatts
Optical & thermal feedback	Incorporated in design
Bandwidth	500 MHz
Operating temperature	-50° to +70°C
Lifetime	100,000 hours
Harmonic distortion	-40 dB
Drive voltage	7 Vd.c. at 1.2 A
Analog input signal	0.75 V P-P at 75 ohms

Receiver (pin photodiode)

Gain	20 dB (variable)
Bandwidth	20 MHz
Output impedance	75 ohms

Fiber optic cable

Number of fibers	2
Loss per kilometer	5 dB
Type	Graded index Manufacturer ITT

SECTION 4

ELECTRICAL DESCRIPTION

The multiplexer design is unique with respect to conventional FDM voice multiplexers employing highly selective narrowband channel filters to conserve bandwidth. Since the optical bandwidth available is on the order of 200 MHz, a simple, inexpensive design approach was taken, whereby the channel RF carriers were spaced between 500 kHz and 1 MHz depending upon the channel number (higher RF channels having the larger spacing). This approach permits the use of simple inexpensive RF channel filters. All 12 FM channel carriers are contained between 1.5 and 9.5 MHz. This baseband spectrum is easily handled by the optical transmitters and receivers.

The circuitry is also unique in that the selectable press-to-talk function for each channel is derived from the RF channel carriers, precluding the need for a separate push-to-talk multiplexer. Each of the 12 channels can be operated as a "hot" channel or press-to-talk channel (as used for keying radios). Also, since FM modulation is used, the channel outputs are unaffected by reasonable changes in the baseband amplitude (± 10 dB) caused by a variance in the optical light power transmitted over the fiber cable.

Details of the multiplex/demultiplex and optical components are given in the following paragraphs.

4.1 TRANSMIT CHANNELS

Since all 12 transmit channels are identical, only one channel is described herein. Figures 3 and 4 show the schematic and PCB (printed circuit board) layout respectively. Two transmit channels are included on one PCB; thus, there is a total of 6 PCB's for 12 channels. The outputs of the 12 channels are summed in a summing amplifier described later in the text.

The input signal is fed to a low gain amplifier via a one-to-one 600-ohm transformer. A Type 747 Operational Amplifier is used which actually contains two 741 Type Amplifiers in one 14-pin dip package. One amplifier is used for channel 1 and the other for channel 2. The amplifier output is used to FM a Type MC 4024A Voltage Controlled Oscillator whose center frequency is set by potentiometer

IB-57,034

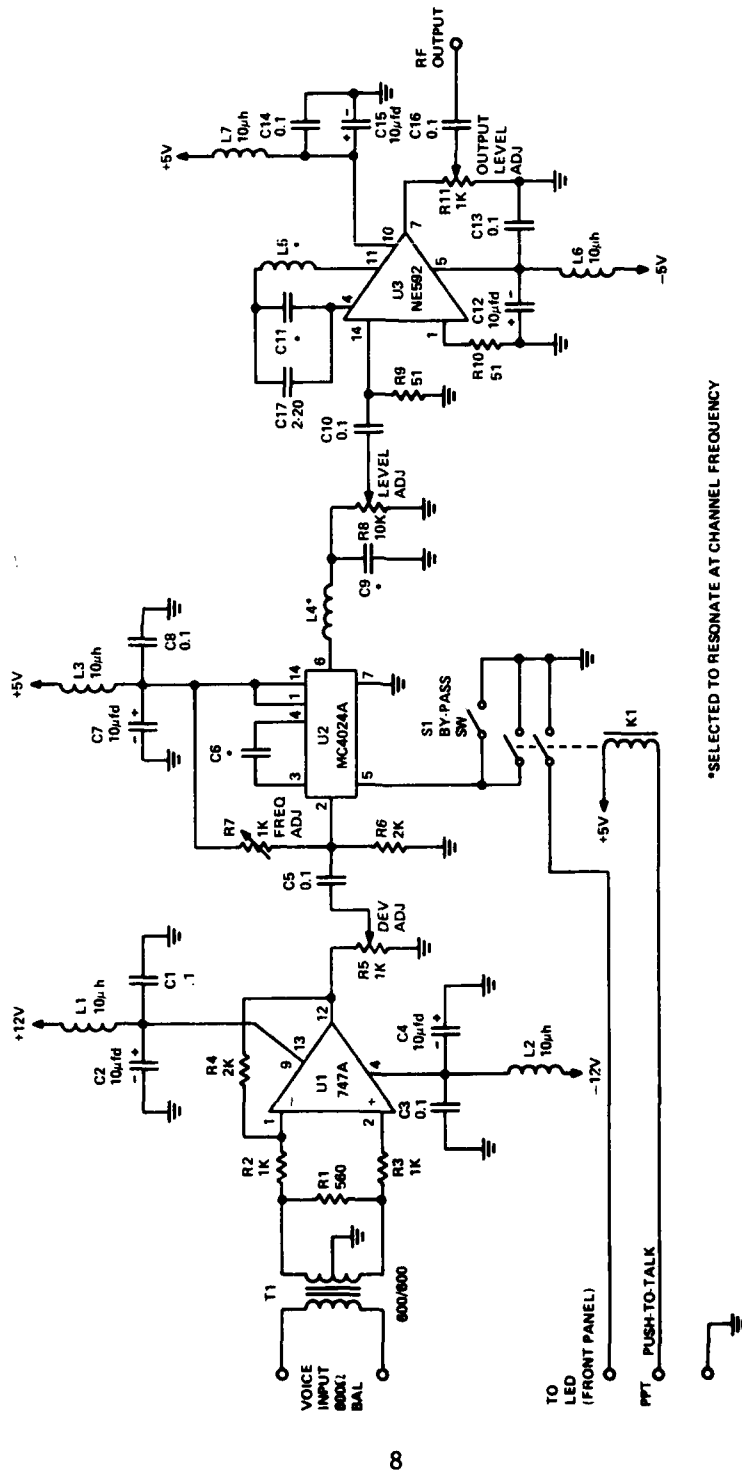

*SELECTED TO RESONATE AT CHANNEL FREQUENCY

Figure 3. Schematic of Transmitter Circuits

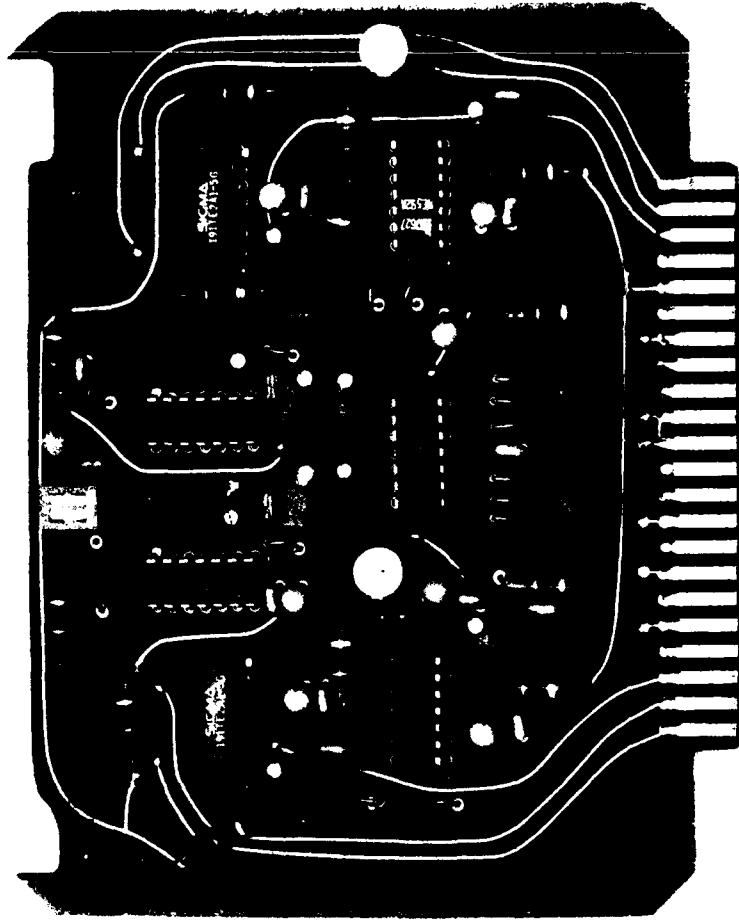

Figure 4. Transmitter Printed Circuit Board

R7. Capacitor C6 is chosen so that the desired operating frequency is within the midrange of R7. Although the MC 4024A VCO (voltage controlled oscillator) chip actually contains two VCO's, only one is used per channel. It was found that if both VCO's were used (one for channel 1 and the other for channel 2), the interaction between oscillators when being FM modulated was intolerable; thus, only one VCO within the package is used per channel. The square-wave output from the VCO is converted to a sine wave via inductance L4 and capacitor C9, which are chosen for each VCO operating frequency.

The output from the VCO is bandpass filtered by active filter U3 (NE 592). Inductor-capacitors C11 and L5 comprise the circuit which is tuned to the VCO frequency. The FM modulated RF carrier output level is adjusted by potentiometer R11.

When the channel is used as a push-to-talk channel, bypass switch S1 is set to the open position. Relay K1 is energized by the remote microphone push-to-talk switch and turns the VCO (U2) on by grounding pin 5. The second set of contacts of K1 is used to light an LED located on the front panel.

R5, the deviation control, is adjusted such that the end-to-end channel gain is unity; that is, a -10 dBm test tone input will produce a -10 dBm test tone output at the receiver when terminated in 600 ohms. Level control R8 is adjusted so that the bandpass filter U3 is not overdriven and the harmonics appearing at the output (pin 7) are down greater than 40 dB from the fundamental VCO frequency.

The 12 transmit channels occupy an RF spectrum of approximately 1.5 to 9.5 MHz with channel spacing of 500 kHz to 1 MHz (the lower channels have the smallest spacing). The actual spacing depends upon the selectivity of the transmit/receive bandpass filters.

Frequency deviations of approximately ± 10 to ± 5 kHz are used with the lower channels using the smaller deviations. The exact deviation per channel depends upon the receiver discriminator sensitivity which decreases with an increase in the RF carrier frequency.

4.2 SUMMING AMPLIFIER

Figures 5 and 6 are the schematic and PCB layout of the summing amplifier, which is used to sum and amplify the individual RF carriers from the transmit channels described in paragraph 4.1. The summing amplifier consists of a Type LH00032 Wideband Amplifier and Type LH 00033 Emitter Follower (U1 and U2). The circuit has an

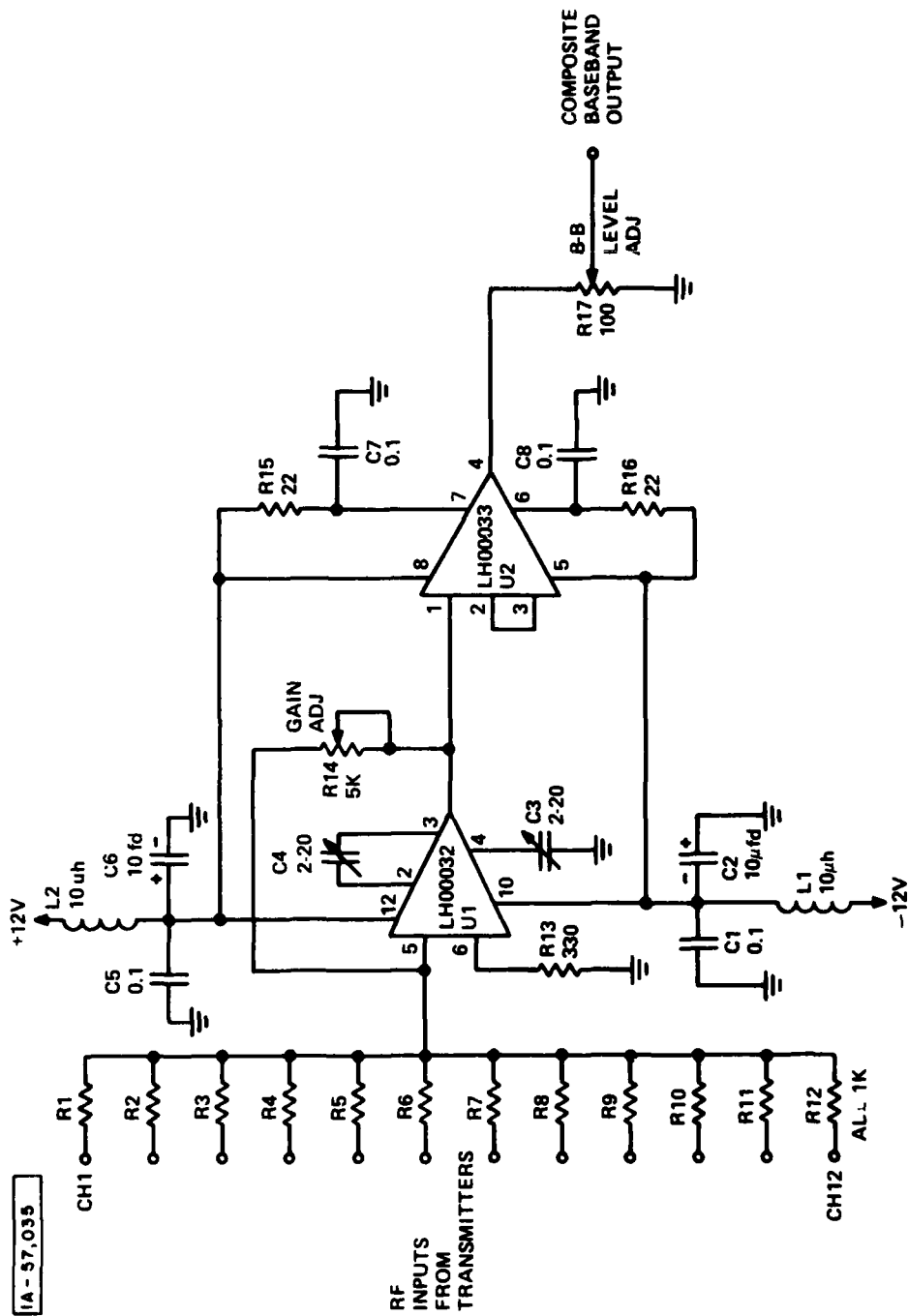

Figure 5. Schematic of Summing Amplifier Circuits

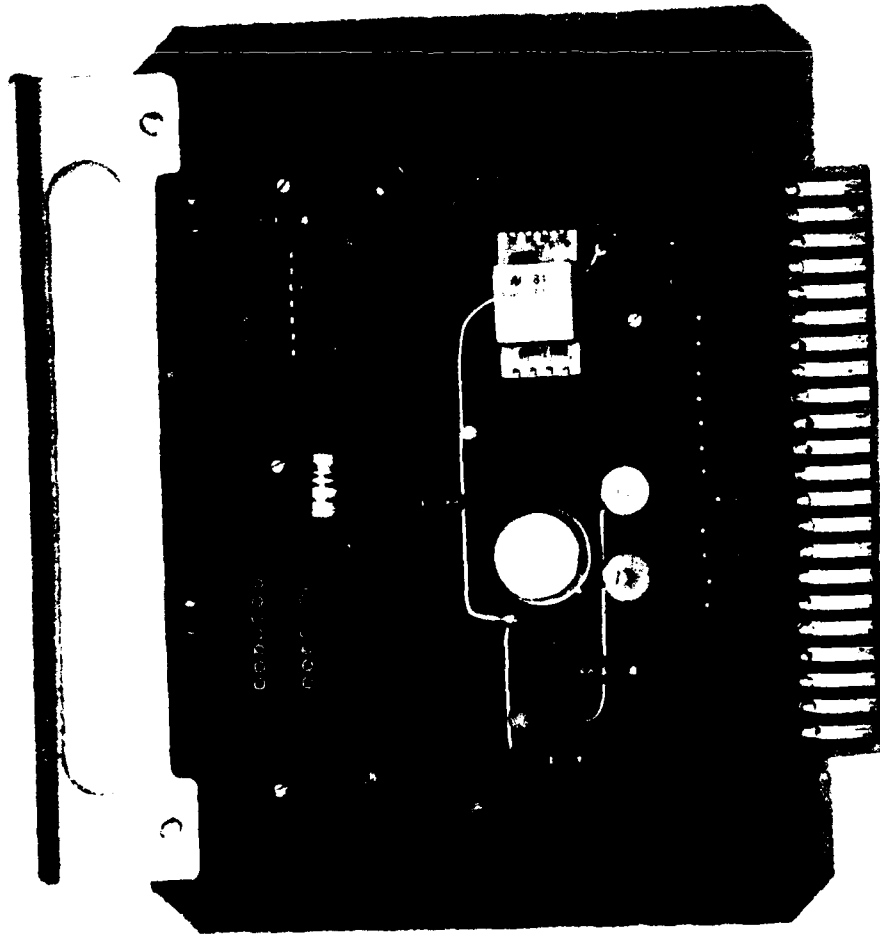

Figure 6. Summing Amplifier Printed Circuit Board

overall gain of five (maximum) and can be adjusted by R14. Resistor R17 is used to adjust the output level of the composite baseband signal. The composite output signal is normally set for approximately 0.75 volts peak-to-peak to be compatible with the fiber optic laser transmitter which drives the fiber optic cable.

4.3 FM RECEIVER MODULES

Figures 7 and 8 show the schematic and PCB layout of the FM receiver module. The circuit consists of an emitter follower input stage, an active bandpass filter, an FM detector, and a relay driver. Since all 12 receiver modules are fed from a common baseband, the emitter follower is used as an isolation stage and prevents excessive loading of the baseband signal due to its high input impedance. The active bandpass filter stage (U2) uses a Type NE592 Wideband Amplifier and is identical to the filter used in the transmit channels. The series L and C are chosen to resonate at the particular channel frequency. The FM detector (Type MC 1357) includes a limiter, discriminator, and output amplifier in a single chip and requires only a single tuned circuit. The value of L and C in the resonant circuit is chosen for the particular channel frequency. Padder capacitors are used in both the bandpass filter and discriminator resonant circuits for fine tuning to the particular channel frequency. A one-to-one 600-ohm output transformer is used to provide the 600-ohm balanced output.

The channel audio bandwidth is approximately 350 Hz to 8 kHz at the 3-dB points. The idle noise runs approximately -48 to -55 dBm depending upon the channel number. The higher channels exhibit the lowest idle noise performance.

Relay K1 is a double-pole, single-throw type. One set of contacts is used to provide a push-to-talk closure to a radio when the sender's microphone push-to-talk switch is closed. The other set of contacts opens the output of the discriminator (U3) when the push-to-talk switch is released. This is necessary to prevent the channel output from going to full noise in the absence of the channel carrier signal (no quieting).

Relay K1 is energized by rectifying some of the RF carrier signal taken from the output of U2. U5 is an emitter follower whose output is rectified and filtered by the network consisting of diode CR1 and capacitor C20. U6 is driven into full conduction by the rectified carrier signal and drives relay K1.

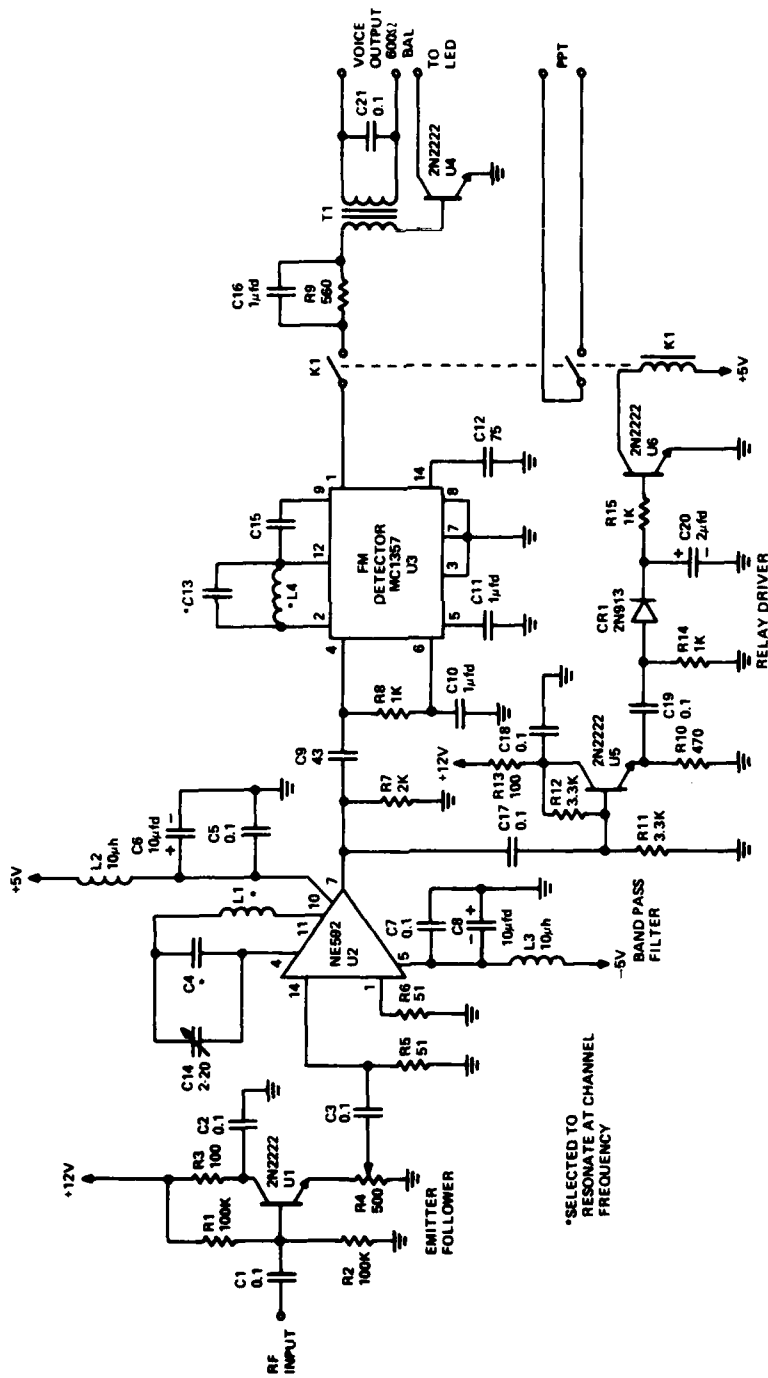

Figure 7. Schematic of Receiver Circuits

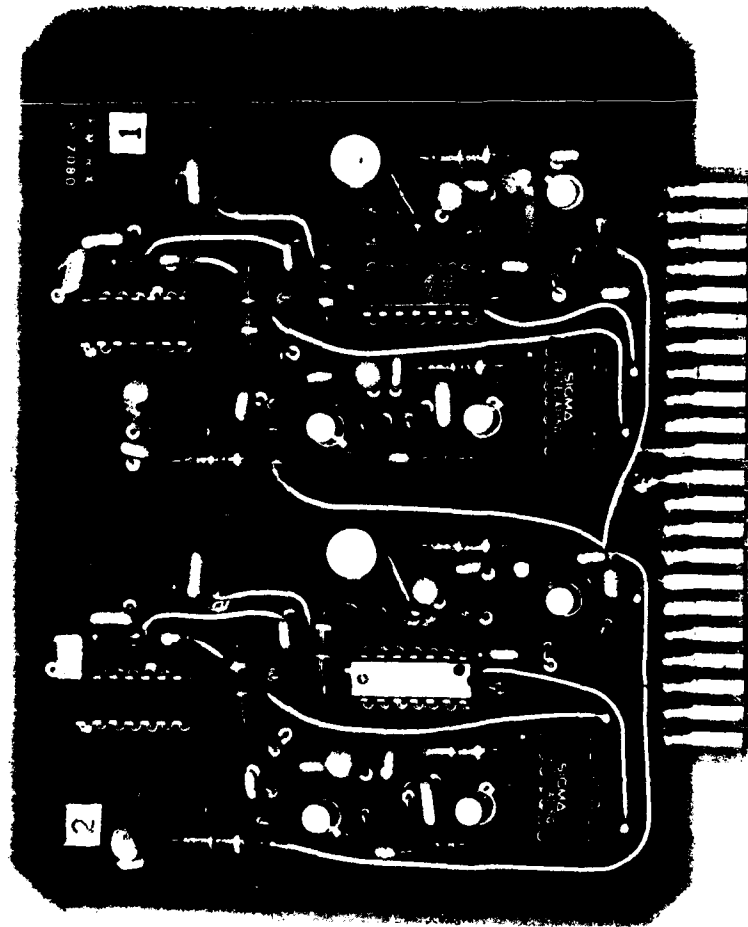

Figure 8. Receiver Printed Circuit Board

U4 is driven into conduction when K1 is energized and completes the circuit of an LED mounted on the front panel (green). This LED indicates the presence of the channel RF carrier. There are 12 such green LED's mounted on the front panel.

4.4 PATCH PANEL

A patch panel is included in the multiplexer unit which provides complete flexibility in patching of the input/output channels to any pair in the 26-pair cables. Short-length patch cables are provided for this purpose.

4.5 CHANNEL RF CARRIER ASSIGNMENTS

The approximate RF channel frequencies are tabulated below.

<u>Channel No.</u>	<u>Frequency (kHz)</u>
1	1560
2	2355
3	2750
4	3325
5	3775
6	4365
7	4820
8	5455
9	6325
10	7335
11	8225
12	9525

In the design, the resonant circuits of the FM discriminators are fixed-tuned to the frequencies shown above using +10% components. The transmitter VCO and transmit/receive bandpass filters were made adjustable and are tuned to the particular discriminator frequency; thus, the frequencies listed above are only approximate (+10%). During channel alignment, the VCO frequency is adjusted for a symmetrical discriminator output, and then the bandpass transmit/receive filters are peaked to that particular frequency.

4.6 OPTICAL TRANSMITTERS AND RECEIVERS

Figure 9 shows the injection laser diode transmitters used. These units were manufactured by General Optronics Corporation and have the performance given in table 1.

These units are equipped with a photodetector on the back side of the laser pellet which measures the average optical power output. A feedback control circuit regulates the drive current so that the maximum optical power output is not exceeded. This overcomes the low temperature problem where the optical power rises drastically as the temperature decreases. In addition, a thermoelectric cooler keeps the injection laser pellet at an operating temperature of less than 35° C and allows the whole unit to operate at ambient temperatures of up to 70° C.

With this compensation, the laser operates in a single mode, and the optical power output is very linear and free from multimode kinks. Thus, it can be used for analog amplitude modulated systems requiring good linearity. The harmonic distortion is approximately -40 dB which will meet most requirements. In this application, between 700 and 800 microwatts optical power was achieved at the laser output pigtail. This, of course, is well in excess of that required for a 1-km link.

Figure 10 shows the optical/electrical receiver units used. The receiver converts the low light level signal from the fiber optic cable to an electrical signal, which is then amplified and buffered before being passed on to the multiplexer circuits.

The fiber optic receiver consists of an input pin photodiode which converts the light energy to an electrical current. This is followed by a transimpedance amplifier which provides an output voltage linearly proportional to the input current. This stage is followed by a variable gain, wideband, power IC (integrated circuit) exhibiting low output impedance to drive a 75-ohm coaxial cable.

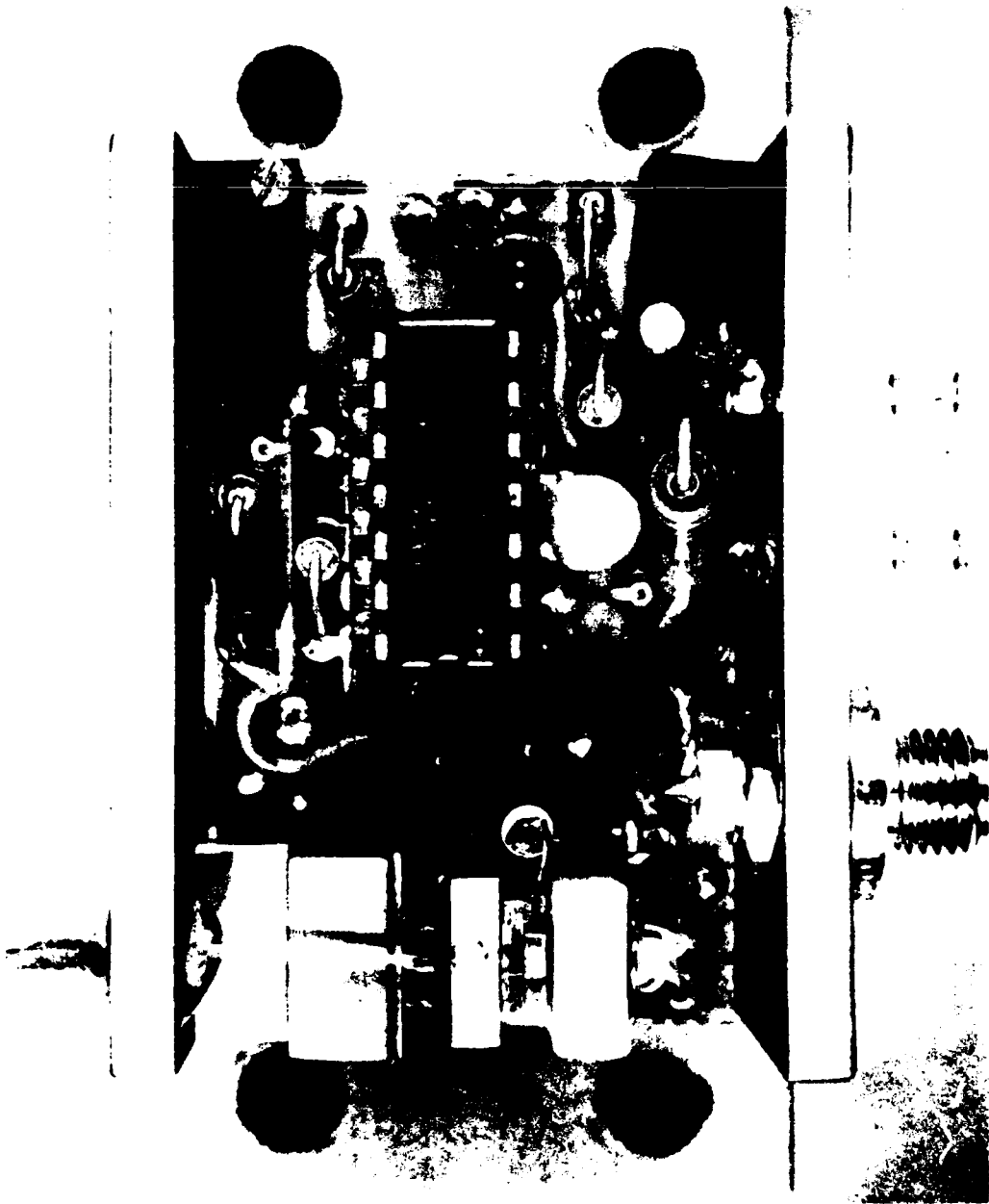

Figure 9. Optical Transmitter Module

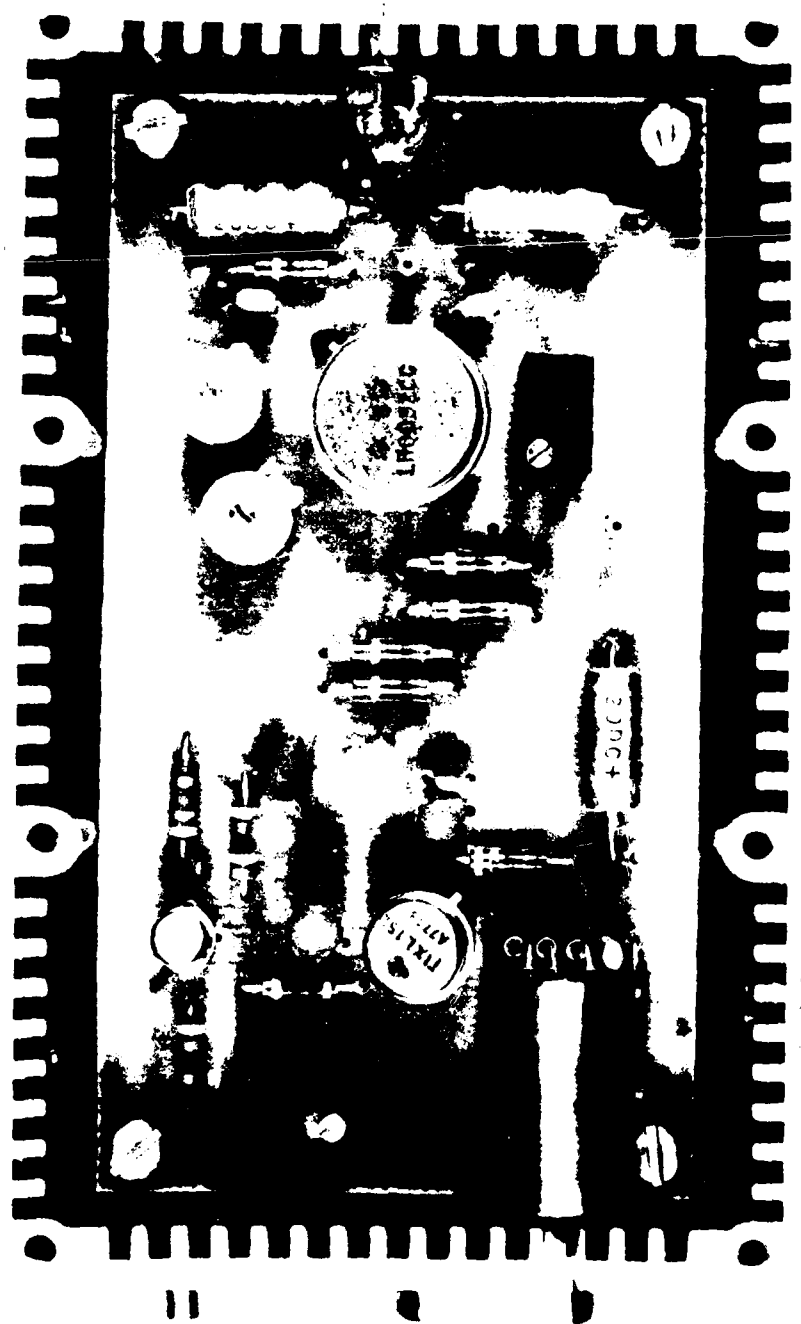

Figure 10. Optical Receiver Module

GLOSSARY

Acronyms

CRC	Control and Reporting Center
CRP	Control and Reporting Post
FACP	Forward Air Control Post
FM	Frequency Modulation
G/A	Ground to Air
HF	High Frequency
IC	Integrated Circuit
LED	Light Emitting Diode
PCB	Printed Circuit Board
RF	Radio Frequency
TACS	Tactical Air Control System
VCO	Voltage Controlled Oscillator



MISSION
of
Rome Air Development Center

RADC plans and executes research, development, test and selected acquisition programs in support of Command, Control Communications and Intelligence (C³I) activities. Technical and engineering support within areas of technical competence is provided to ESD Program Offices (POs) and other ESD elements. The principal technical mission areas are communications, electromagnetic guidance and control, surveillance of ground and aerospace objects, intelligence data collection and handling, information system technology, ionospheric propagation, solid state sciences, microwave physics and electronic reliability, maintainability and compatibility.

