

MICROCOPY RESOLUTION TEST CHART
NATIONAL BUREAU OF STANDARDS-1963-A

BY THE COMPTROLLER GENERAL

Report To The Congress

OF THE UNITED STATES

②

AD A 0 96236
⑥

DOD Participation In The Space Transportation System. Status And Issues.

LEVEL II

The Space Transportation System has been delayed 3-1/2 years and the cost of Defense participation in the program has increased \$1.6 billion—from about \$1.2 billion in fiscal year 1978 to about \$2.8 billion in fiscal year 1982.

⑫ 56

DTIC
ELECTE
MAR 12 1981

To date, the delays have not resulted in any known operational degradation in Defense space capabilities. Continuing uncertainties, however, may further delay Defense's use of the full capabilities offered by the System, increase costs, or degrade future Defense operational capabilities in space.

⑪ 28 Feb 82

The Secretary of Defense and the Administrator of the National Aeronautics and Space Administration should inform the Congress of the options being considered for maintaining an assured launch capability for defense and civil missions and the key assumptions, costs, and risks associated with each option. The Secretary of Defense should also provide the Congress information on the total cost of Defense participation in the Space Transportation System program.

DBG FILE COPY



⑭ GAO/MASAD-81-6
FEBRUARY 28, 1981

472287 81 3 11 015

Request for copies of GAO reports should be sent to:

**U.S. General Accounting Office
Document Handling and Information
Services Facility
P.O. Box 6015
Gaithersburg, Md. 20760**

Telephone (202) 275-6241

The first five copies of individual reports are free of charge. Additional copies of bound audit reports are \$3.25 each. Additional copies of unbound report (i.e., letter reports) and most other publications are \$1.00 each. There will be a 25% discount on all orders for 100 or more copies mailed to a single address. Sales orders must be prepaid on a cash, check, or money order basis. Check should be made out to the "Superintendent of Documents".



COMPTROLLER GENERAL OF THE UNITED STATES
WASHINGTON, D.C. 20548

B-201272

To the President of the Senate and the
Speaker of the House of Representatives

This report presents our views on the major issues concerning the Department of Defense's participation in the Space Transportation System.

For the past several years, we have reported annually to the Congress on the status of selected major acquisition programs. This report is one in a series that is being furnished to the Congress for its use in reviewing fiscal year 1982 requests for funds.

We are sending copies of this report to the Director, Office of Management and Budget; the Secretary of Defense; the Secretary of the Air Force; and the Administrator, National Aeronautics and Space Administration.

James B. Staats
Comptroller General
of the United States

Accession For	
NTIS GRA&I	<input checked="" type="checkbox"/>
DTIC TAB	<input type="checkbox"/>
Unannounced	<input type="checkbox"/>
Justification	
By _____	
Distribution/	
Availability Codes	
Dist	Avail and/or Special
A	

D I G E S T

The operational availability of the Space Transportation System has been delayed 3-1/2 years. Delays have resulted from identification of new requirements, funding constraints, and development difficulties with the system.

While the delays have had several effects on Department of Defense (DOD) participation in the program, to date there has been no known operational degradation in DOD space capabilities. However, the cost of DOD's participation in the program has grown from about \$1.2 billion to about \$2.8 billion--an increase of \$1.6 billion (133 percent)--between fiscal years 1978 and 1982. This increase does not reflect the total growth in the cost of DOD's participation in the program. (See pp. 29 to 33.)

Continuing uncertainties may further delay DOD's use of the full capabilities offered by the system, increase costs, or degrade future DOD operational capabilities in space. (See ch. 2.)

The system consists of the Space Shuttle (four orbiters each with a large external propellant tank and two solid rocket motors); upper stages to transfer payloads from the Shuttle's low Earth orbits to higher orbits; Spacelab for conducting experiments in space; launch and landing facilities and associated ground support equipment; and simulation, training, and mission control facilities necessary for operation. The aircraft-like orbiters and the solid rocket motors are reusable components; the external tank is expendable.

The National Aeronautics and Space Administration (NASA)/DOD program to develop the Space

Transportation System is closely intertwined, and problems in meeting performance goals or milestones by one agency will affect the other. For example, NASA delays in meeting operational dates caused DOD to procure more expendable vehicles than originally planned and delay transitioning of military payloads from expendable launch vehicles--such as the TITAN III--to the Space Transportation System. (See pp. 6 to 9.)

Because of difficulties in obtaining information from the Air Force and a tight reporting deadline, GAO is not sure it has the most current and complete cost data on the program.

DELAYS AT VANDENBERG LAUNCH AND LANDING SITE

The operational date of launch and landing facilities being built at Vandenberg Air Force Base has been delayed 1-1/2 years from December 1982 to June 1984. System program office officials said the June 1984 date was high risk and virtually impossible to meet. They believe a more achievable date is October 1984. (See pp. 10 and 11.)

SECURE COMMUNICATION NEEDS

For classified missions, DOD needs secure communication lines between Vandenberg Air Force Base and Kennedy and Johnson Space Centers and secure lines between Johnson and NASA's Telemetry and Tracking Center at Goddard Space Flight Center, Maryland. Further, full use of the Space Shuttle's capabilities is dependent upon availability of the NASA Tracking and Data Relay Satellite System, which has slipped from December 1980 to April 1983. If this system is not available by April 1983, then alternate secure command, control, and communications routes must be developed to support the first classified operational launch. Program officials are studying "work-around" solutions and the need for additional secure communications lines. Accordingly, the potential effects on operational dates and costs are not yet known. (See pp. 13 to 15.)

UNCERTAIN AVAILABILITY OF
INERTIAL UPPER STAGE

The Inertial Upper Stage development program has experienced difficulties in achieving its required capabilities. As a result, the initial operating capability has slipped 1 year from July 1980 to July 1981 and program costs have increased from \$284.5 million to \$386.6 million in 1978 dollars. (See p. 19.)

Major factors in the delays and cost growths were the main contractor's underestimating the technical complexity of the Inertial Upper Stage and inadequate management attention by the contractor and the Air Force. These problems led the Air Force to renegotiate the contract for development and production of nine Inertial Upper Stages and place a ceiling of \$462.4 million on the contract. This is not a maximum ceiling since it is subject to increase with changes in the scope of work. As of September 1980, additional modifications increased the contract amount to \$471.8 million. (See pp. 19 and 20.)

In September 1980 the Air Force reported to the House and Senate Military Construction Subcommittees that Inertial Upper Stage development was on schedule and would support operational requirements. In GAO's opinion, however, areas of major uncertainty exist. Motor development efforts still are experiencing difficulties, software will not be completely checked out until early 1982, and there is a possibility the airborne support equipment may have to be redesigned. The first two areas of concern could delay the first TITAN/Inertial Upper Stage launch scheduled for November 1981. The third area could delay the first Space Shuttle/Inertial Upper Stage launch scheduled for September 1982. (See pp. 20 and 21.)

POTENTIAL NEED FOR CONTINUED USE OF
EXPENDABLE VEHICLES AND/OR MORE ORBITERS

Recent comments by the Secretary of the Air Force and top NASA officials, as well as studies conducted by NASA and an Air Force contractor, indicate continued use of expendable

launch vehicles and/or more orbiters may be required. GAO was advised that funds for a fifth orbiter are expected to be included in the NASA fiscal year 1982 budget. (See pp. 26 to 28.)

In view of past problems with the Space Transportation System, continuing uncertainties, and the lack of operational experience with the system, it is essential that the Congress have a comprehensive understanding of the options available for meeting launch requirements--particularly critical DOD requirements.

RECOMMENDATIONS

The Secretary of Defense should provide the Congress information on the total cost of DOD participation in the program, including those costs funded by individual satellite and other programs.

Further, the Secretary of Defense and the NASA Administrator also should provide the Congress with comprehensive information on the options being considered for maintaining an assured launch capability for defense and civil missions and the key assumptions, costs, and risks associated with each option. The study should identify all known and projected critical and noncritical missions and the advantages and disadvantages of continuing use of expendable launch vehicles and/or increasing the number of orbiters. Information should also be provided on probable effects of delaying or canceling some noncritical flights until operational experience with the Space Transportation System is obtained.

AGENCY COMMENTS

GAO did not request official comments on this report because of the tight reporting deadline. Instead, a draft of the report was discussed with high level DOD and NASA officials associated with management of the program to assure that the report is accurate and complete.

Though not solicited, NASA provided GAO with written comments. (See app. II.) NASA

disagreed with the draft report in general and with the conclusions and recommendations, particularly because NASA officials believed the report implied that DOD's difficulties were due solely to NASA's delays. GAO clarified the report to point out that NASA contributed but was not the sole cause of problems with the program. (See pp. 35 and 36.)

C o n t e n t s

		<u>Page</u>
DIGEST		i
CHAPTER		
1	INTRODUCTION	1
	Background	1
	NASA/DOD responsibilities	2
	Objectives, scope, and methodology	2
2	DELAYS IN DOD'S STS EFFORTS	6
	Additional ELVs needed as backups to the Shuttle	6
	Effects on other DOD space programs	8
	Delays at Vandenberg launch and landing site	10
	Secure communication needs	13
	Conclusions	15
3	RISKS AND UNCERTAINTIES AFFECTING DOD SPACE EFFORTS	16
	Uncertain availability of IUS	16
	Delays in developing CSOC	21
	Survivability of STS	22
	Potential need for continued use of ELVs and/or more orbiters	26
	Conclusions	28
4	COST OF DOD PARTICIPATION IN STS IS INCREASING	29
	Cost increases in DOD's STS acquisition program	29
	Visibility needed into total DOD costs for STS efforts	31
	Conclusions	33
5	CONCLUSIONS AND RECOMMENDATIONS	34
	Conclusions	34
	Recommendations	35
	Agency comments	35

APPENDIX

Page

I	Our previous STS reports	37
II	December 31, 1980, letter to GAO from the Acting Associate Director, NASA	38
III	Key milestone dates	46

ABBREVIATIONS

CSOC	Consolidated Space Operations Center
DOD	Department of Defense
ELV	expendable launch vehicle
FYDP	Five Year Defense Program
GAO	General Accounting Office
IOC	initial operating capability
IUS	Inertial Upper Stage
NASA	National Aeronautics and Space Administration
OMB	Office of Management and Budget
STS	Space Transportation System

CHAPTER 1

INTRODUCTION

This is our 11th study 1/ of the Space Transportation System (STS). This report discusses the status and issues surrounding Department of Defense (DOD) participation in the program. Past reports have discussed technical problems, schedule delays, and cost increases encountered by the National Aeronautics and Space Administration (NASA) in developing STS.

NASA's problems with the Space Shuttle's main engine, thermal protection system, schedule delays, and cost increases are known and have been scrutinized by the Congress. Not as well known, however, is that DOD, one of the principal users of STS, also has had technical problems, schedule delays, and cost increases in developing and acquiring its portion of STS.

STS is a high technology program pushing the state of the art in many areas, such as a reusable spacecraft, main engines, and thermal protection systems. Accordingly, it is worthwhile to note that technical problems, schedule delays, and cost increases encountered in developing STS are problems common to other high technology programs.

The joint NASA/DOD program to develop STS is closely intertwined, and a problem in meeting performance goals or milestones by one agency will affect the other. For example, NASA delays in meeting operational dates caused DOD to delay transition of military payloads from expendable launch vehicles (ELVs)--such as the TITAN III--to the Shuttle. (See ch. 2.) The delays also required DOD to procure more ELVs than originally planned. Also, there are indications the availability of STS for use by DOD may be further delayed as a result of technical problems and budgetary constraints encountered by both NASA and DOD. (See ch. 3.) Chapter 4 discusses the ramifications these delays, risks, and uncertainties have had on the cost of the STS defense program.

BACKGROUND

In January 1972 the President authorized NASA to develop a partially reusable STS as a national means of

1/Appendix I lists our 10 prior reports on STS.

transporting payloads to and from space to meet civil and defense needs.

STS consists of the Space Shuttle (four orbiters, each with a large external propellant tank and two solid rocket motors); upper stages to transfer payloads from the Shuttle's low Earth orbits to higher orbits; Spacelab for conducting experiments in space; launch and landing facilities and associated ground support equipment; and simulation, training, and mission control facilities necessary for operation of the system. The aircraft-like orbiters and the solid rocket motors are reusable components; the external tank is expendable. The flight elements of the Shuttle are depicted on page 3 and a size comparison of the Shuttle to a TITAN/CENTAUR launch vehicle and to commercial jet liners is on page 4.

NASA/DOD RESPONSIBILITIES

NASA has overall management responsibility for STS, including development and acquisition of the Shuttle flight hardware (orbiters, solid rocket motors, and external tank); launch and landing facilities at Kennedy Space Center in Florida; and the flight planning and control facilities at Johnson Space Center, Texas. The Air Force, DOD's executive agent for the Shuttle, is responsible for (1) developing an Inertial Upper Stage (IUS) for use by both NASA and DOD to deploy payloads from the Shuttle orbit into higher orbits (see p. 16) and (2) developing and operating Shuttle launch and landing facilities at Vandenberg Air Force Base, California, and DOD-peculiar facilities at Vandenberg; Cape Canaveral Air Force Station, Florida; and Kennedy and Johnson Space Centers. DOD has also identified a need for a Consolidated Space Operations Center (CSOC) to be located near Colorado Springs, Colorado.

OBJECTIVES, SCOPE, AND METHODOLOGY

The objective of the review was to provide the Congress with information on the status and significant issues pertaining to DOD efforts to acquire STS facilities and equipment.

Our review work was performed at the Office of the Secretary of Defense; Headquarters, United States Air Force; Headquarters, NASA; the Air Force Systems Command's Space Division in El Segundo, California; Kennedy Space Center, Florida; and Johnson Space Center, Texas. We reviewed project plans, studies, status reports, and other documents. We also spoke with DOD and NASA officials at the above locations.

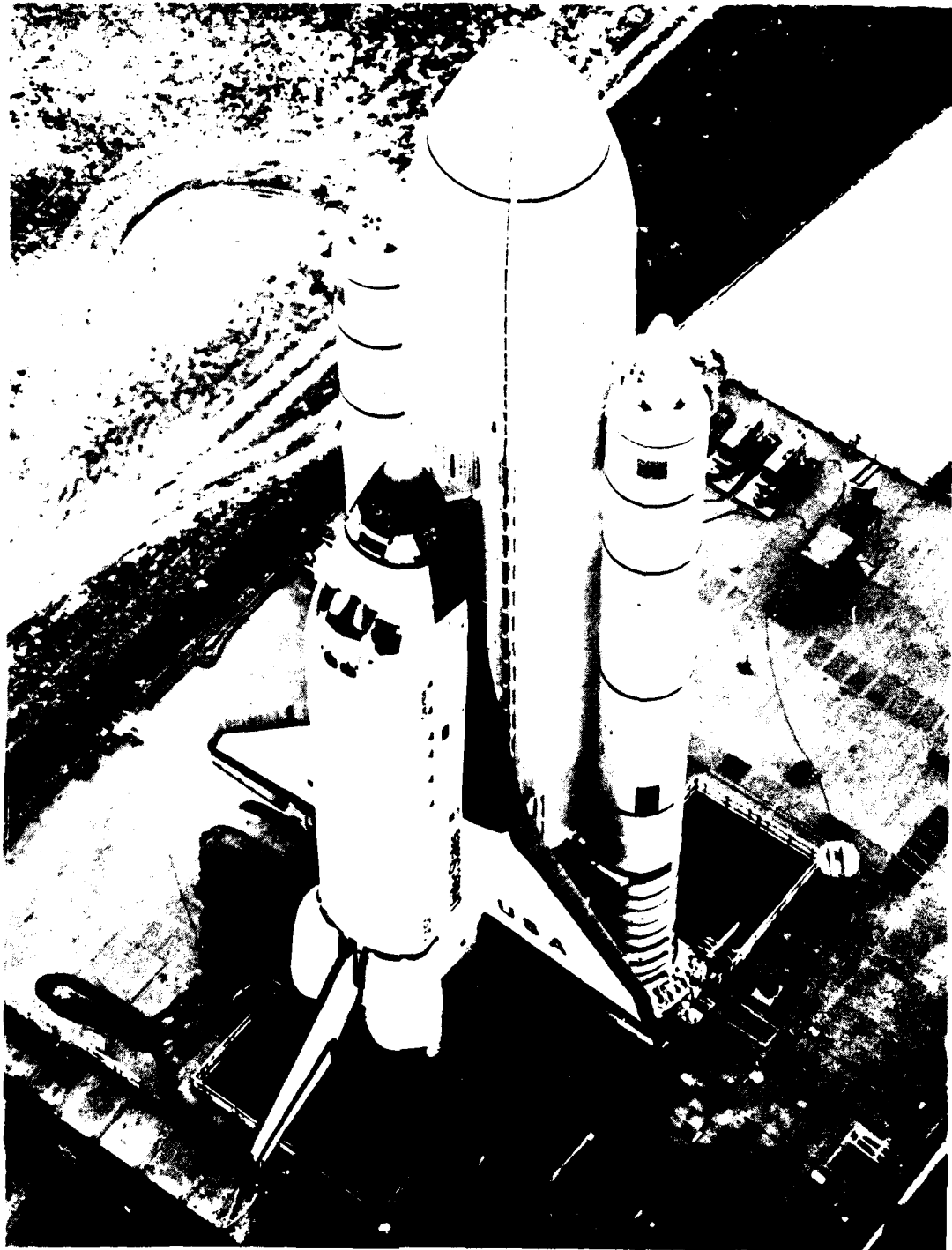

Courtesy of NASA

"SPACE SHUTTLE SYSTEM"

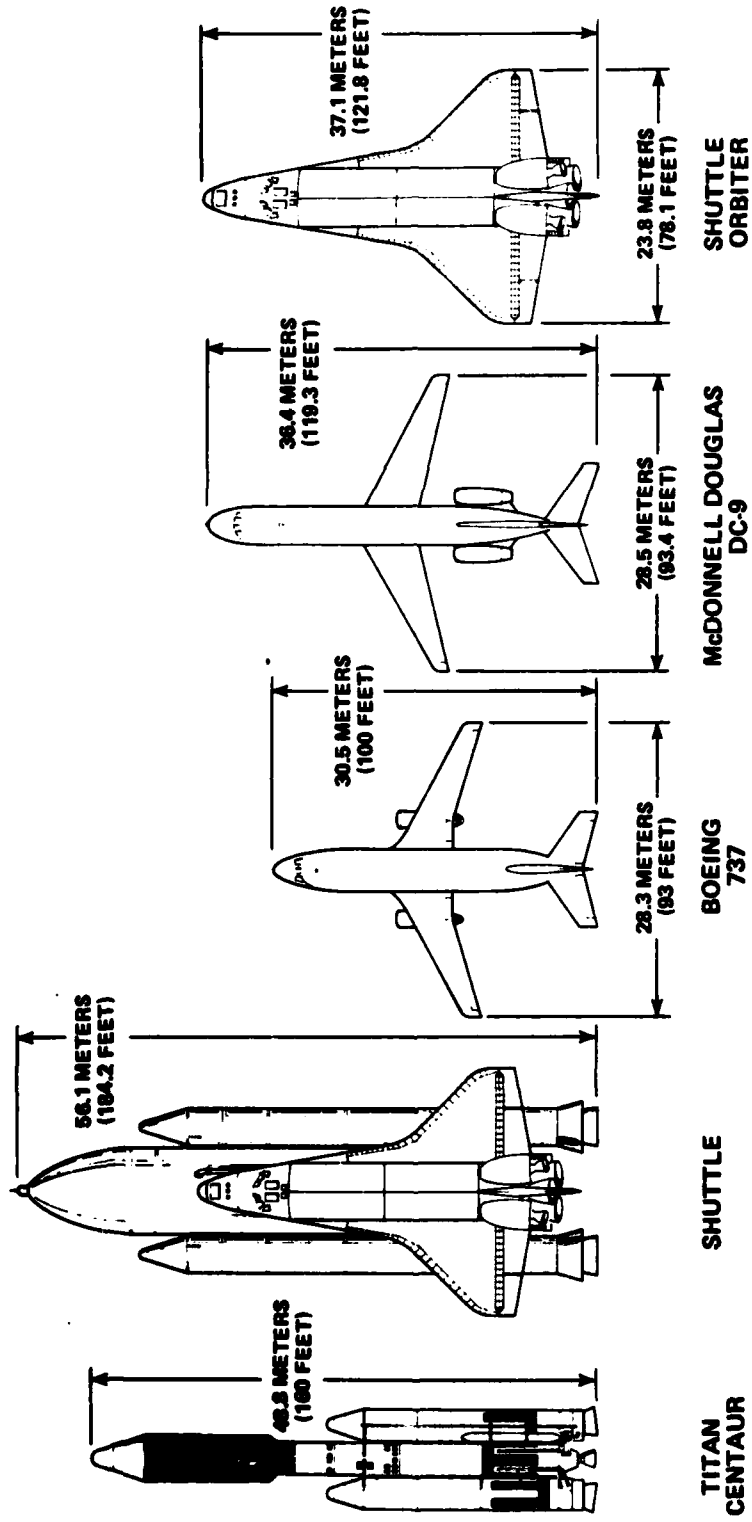

SHUTTLE/ORBITER SIZE COMPARISON

SOURCE: NASA

The results of our interviews and review of documentation were combined in what we believe to be an accurate description of the status and issues surrounding DOD's participation in the STS program.

This report does not identify specific space programs because of the classified nature of some programs. We did not evaluate the need for STS, validity of need dates, reasonableness of the national mission model, or the need for CSOC.

Because of tight reporting deadlines, we did not request official comments on this report. NASA, however, did provide us with written comments. (See app. II.) Also, a draft of the report was discussed with high level DOD officials associated with management of the program to assure that the report is accurate and complete. Because of difficulties in obtaining information from the Air Force and our tight reporting deadline, we are not sure we have the most complete and current cost data on the program. (See p. 29.)

CHAPTER 2

DELAYS IN DOD'S STS EFFORTS

The operational availability of STS has been delayed 3-1/2 years from March 1979 to September 1982. 1/ This delay, attributed to technical problems and budgetary constraints encountered by NASA, caused DOD to

--acquire additional backup launch ELVs and

--delay the transition--from ELVs to STS--of some DOD space programs.

Further, the STS delay, in part, caused DOD to delay the operational availability of STS launch and landing facilities at Vandenberg.

DOD officials stated that the STS delays have not resulted in any known operational degradations, and if current schedules are met, there should be no adverse mission effects to DOD space programs. In our opinion, however, continuing uncertainties may further delay DOD's use of the full capabilities of STS, increase costs, or degrade future DOD operational capabilities in space.

ADDITIONAL ELVs NEEDED AS BACKUPS TO THE SHUTTLE

Delays in achieving an operational STS have caused the Air Force to increase its requirements for TITAN III (34)D ELVs. These ELVs are to maintain an assured launch capability for critical DOD satellites in the event of problems or delays with the Shuttle.

ELV backup strategy

The Air Force strategy for backups is to maintain an assured capability to launch critical missions during the first 2 years of operations at Kennedy and first year of operations at Vandenberg. Another part of this strategy is to maintain critical TITAN production capability until STS is operational.

Based on this strategy and with the first DOD operational launch from Kennedy planned for July 1980, the Air

1/ STS milestone dates are shown in appendix III.

Force planned to procure five backup ELVs. Subsequently, as the Shuttle was delayed to September 1981, the quantity of backup ELVs was increased to five complete vehicles and two sets of long-lead materials. This increase in backup launch vehicles served to extend the critical TITAN production capability to September 1981. However, since then, NASA delayed the Shuttle initial operating capability (IOC) to September 1982. This latest delay reopened a production capability gap.

Status of ELV procurements

As a result of the IOC delay to September 1982, the fiscal year 1981 budget contained \$66 million to fully fund the assembly of two sets of long-lead materials. These materials were purchased with \$44 million in reprogramed fiscal year 1980 funds. This action resulted in a total acquisition of seven ELVs as backups. However, two missions planned for Shuttle launches have--as a result of the uncertainty over the availability of the Shuttle--been rescheduled to be launched on ELVs. This rescheduling reduced the number of backup ELVs to five.

Air Force and program office officials said the Office of the Secretary of Defense has tentatively included in the fiscal year 1982 budget funds for two additional TITAN III (34)Ds to maintain the production capability. Also, \$5 million in fiscal year 1981 funds is being reprogramed for long-lead materials for these TITANs. However, a firm decision has not been made on the total number of backups to be procured.

As part of the current assessment of the number of backup boosters needed, the program office identified two options which it considers viable. These options will maintain the critical production capabilities and extend the ability to launch critical satellites to at least 1986. One option considers the acquisition of three TITAN III (34)Ds at a cost of \$237 million. The other option considers the acquisition of three TITAN III (34)Ds per year over several years. The cost of this latter option was estimated at \$559 million through 1984.

Backup ELVs may also be needed for noncritical satellites

The present planning for backup ELVs does not provide backups for satellite programs not designated as critical. For example, during fiscal years 1983 to 1985, there are

13 noncritical satellites scheduled for launch on the Shuttle which are not backed up with ELVs.

To the degree scheduled launch dates of these satellites remain firm and the satellites are capable of being launched on ELVs, we believe the failure to provide backup launch capabilities for these satellites could lead to degradation in mission capabilities and/or delays in the operational availability of new systems. Air Force officials said that if backups were required for these satellites, DOD could probably use some of the ATLAS and DELTA launch vehicles used by NASA.

The present backup strategy also does not consider an extended Shuttle grounding or loss of a Shuttle. Probable effects of the latter two events are discussed on page 27.

EFFECTS ON OTHER DOD SPACE PROGRAMS

The uncertain availability of the Shuttle has caused two DOD space programs to delay transitioning from ELVs to the Shuttle. These two satellites were converted from planned Shuttle launches to launches on ELVs. Also, two other satellite programs may be affected if the Shuttle is delayed further.

The uncertainty and changes have increased the costs of some space programs and may degrade operational capabilities by delaying planned launches and/or delaying introduction of more capable and survivable satellites. Cost effects resulting from the above are not reflected in STS program costs but rather are included in the costs of the individual satellite programs. (See p. 31.)

Transitioning delays

Two satellite programs have delayed transition from ELVs to the Shuttle from 1 to 2 years. Both programs were scheduled to be transitioned in fiscal year 1983; one is now scheduled for transitioning in fiscal year 1984 and the other in fiscal year 1985.

Reasons for delaying the transition date and deciding to launch the first satellite on an ELV included (1) the need for an assured launch in 1983 to preclude a gap in operational capabilities during the 1983-85 time frame, (2) the need for better defined Shuttle environment data such as noise and shock levels, and (3) lower costs that would result by not designing the satellite for launch on

both the Shuttle and an ELV. In August 1980 the Secretary of the Air Force directed this satellite be launched on an ELV.

Relative to the second satellite program, the decision to delay transitioning will require (1) procurement of an old model satellite and (2) conversion of a backup TITAN III (34)D to a TITAN III B. An official of the satellite program said costs of procuring the old model satellite were estimated at about \$70 million plus an additional \$3 to \$5 million to convert the TITAN III (34)D. Also, an AGENA upper stage would be required. The cost of the upper stage was unknown, but the official estimated it would cost about \$3 million to complete the upper stage for use with this satellite. An official of the STS program office said that there would be about a \$9 million reduction in the cost of the ELVs since solid rocket motor strap-ons would not be needed for the TITAN III B.

The official of the satellite program said that additional funds were not requested. Rather, they reprogrammed procurement funds from a new model satellite to procure the old model satellite. These actions will result in a deferral in the introduction of the new model satellite.

Use of an old model satellite was required because the new model satellites were optimized for launch on the Shuttle. Consequently, the new models could not be made compatible for launch on ELVs without incurring significant costs.

Potential future effects

In addition to the above satellites, two other satellites may also be affected if the Shuttle is delayed further. These programs are scheduled for launch in fiscal years 1983 and 1984. Both of these satellites are Shuttle-optimized, and consequently, a Shuttle delay would delay the satellite launch dates. However, if delays are not viewed as viable alternatives, then significant costs would have to be incurred to make the satellites capable of being launched on ELVs.

These two satellites are not compatible with launch on a standard TITAN III (34)D backup vehicle. A decision to launch these satellites on ELVs would require for one satellite, development of a TITAN/CENTAUR launch capability, and for the other satellite, development of a new fairing for use on the TITAN III (34)D.

The costs of such developments are being studied, and firm costs are not known. Program officials estimated it could cost about \$250 million to reactivate the TITAN/CENTAUR launch pad, acquire a CENTAUR upper stage, and integrate the satellite to the launch vehicle. The cost of developing the fairing for the second satellite was estimated to cost about \$60 million.

Program officials also estimated it would take about 36 months to accomplish the tasks necessary to launch these two satellites on ELVs. Consequently, if these satellites were to be launched on ELVs, decisions would have been needed in the October-November 1980 time frame to protect the presently scheduled launch dates. In one instance, even if a decision had been made in October or November, the launch of the satellite would still be delayed approximately 6 months because of the long leadtime required to build a CENTAUR. As of January 21, 1981, a final decision had not been made.

DELAYS AT VANDENBERG LAUNCH AND LANDING SITE

The IOC date at the Vandenberg launch and landing site has been delayed 18 months from December 1982 to June 1984. ^{1/} In 1977 the December 1982 date was changed to June 1983 because of Air Force budget problems and a NASA delay in the delivery date of Orbiter 103, which is planned to be used on the first DOD operational launch from Vandenberg.

In commenting on a draft of our report, NASA officials said STS delays were not responsible for delays in activation of Vandenberg. We noted, however, that in March 1978 hearings before subcommittees of the House Committee on Appropriations, an Air Force official said the 6-month delay in Vandenberg activation (from December 1982 to June 1983) was to rephase the program to make it compatible with the revised NASA delivery schedule of the orbiters. Vandenberg activation was keyed to delivery of Orbiter 103 in September 1982 to support a mid-1983 IOC.

In January 1979 the IOC date at Vandenberg was postponed to December 1982 as a result of several factors, including (1) a delay in DOD satellite launch requirements and (2) the need to modify the Vandenberg launch pad design to incorporate the ability to launch a Shuttle with greater thrust than originally planned. This increase in thrust is required

^{1/}STS milestone dates are shown in appendix III.

because of an expected shortfall in the Shuttle's payload carrying capabilities.

In May 1980 the Air Force announced another delay, to June 1984, before Vandenberg will be operational. This 6-month postponement was caused by a significant increase (about \$82 million) over the Government estimate for construction in contractor bids received in January 1980.

DOD and Air Force officials stated the delays would not affect national security launches out of Vandenberg, provided current orbiter delivery schedules are met. The first civil and defense STS launches out of Vandenberg are presently planned for mid- to late-1984.

However, as early as March 1980, program office officials expressed concern the June 1984 date was high risk. In August 1980 the Secretary of the Air Force was told by program officials that the June 1984 date was virtually impossible to meet and that an October 1984 date was more likely. Nevertheless, the Air Force did not change the IOC of June 1984. This date does not provide for contingencies, such as labor strikes or shortages of materials, and will require installation of support equipment while construction is ongoing.

Thrust augmentation

Because of an expected shortfall in Shuttle payload carrying capability for west coast launches, NASA identified a need to increase the thrust of the Shuttle. This increase required the Air Force to incorporate into its Vandenberg launch pad design the ability to handle greater thrusts than originally contemplated. The redesign efforts contributed to a 6-month delay (from June 1983 to December 1983) in achieving IOC at Vandenberg and increased costs by about \$51 million.

The Shuttle was originally projected to have a 32,000-pound payload capability for west coast launches. However, as a result of weight increases, it was estimated that at maximum, without thrust augmentation, the Shuttle would only be able to lift about 24,000 pounds. To make up for this shortfall in performance, NASA decided in November 1979 to use a liquid boost motor concept to increase the Shuttle's thrust. This thrust augmentation was expected to increase the Shuttle's payload capabilities to about 41,000 pounds.

In August 1980 NASA informed the Air Force that it was studying other performance augmentation options. These studies are to see if greater thrust can be achieved at a lower cost than that of the liquid boost motors. According to NASA officials, the reason for evaluating other options was that the need date for thrust augmentation had slipped to June 1986.

The 1-year delay in the need for thrust augmentation at Vandenberg is not expected to have any effect on the design or construction of the launch pad. Before the delay, the program office was concerned that design of support facilities at Vandenberg would precede thrust augmentation design since NASA's schedule showed no full-scale design effort until fiscal year 1982.

Additional delay possible at Vandenberg

Because of increasing concern on the part of the Congress as to NASA's ability to meet milestone dates, the fiscal year 1981 Military Construction Appropriations bill prohibits obligation of funds for construction of Vandenberg STS facilities until after the successful rollout of the Shuttle from the Orbiter Processing Facility at Kennedy Space Center. This event was scheduled by NASA for November 23, 1980, and occurred on November 24, 1980.

The limitation will mean a 30- to 45-day delay in the advertising and contract award for construction of the runway, the solid rocket motor, and the external tank processing and storage facilities. These facilities were scheduled for advertising in November 1980 and contract award in January 1981. 1/ After rollout, when the construction packages are advertised, the program office is planning to retain the original completion dates to determine if the contractors can meet them. If the contractors indicate they cannot, the effects will be assessed at that time.

The appropriations bill also deleted \$18 million in STS construction funds primarily for a solid rocket motor dis-assembly facility at Port Hueneme, California. The Air Force was planning to defer construction of this facility until 1982 and reprogram the funds to complete the launch pad at Vandenberg. The Air Force advised the Congress in April

1/In January 1981 program officials said the request for bids for two critical facilities were issued on January 9, 1981, and contract award is planned for March 10, 1981.

1980 that this reprogramming was planned because of the technical complexities and cost overruns experienced with the launch pad. In December 1980 the House and Senate Appropriations Committees approved reprogramming of \$13.7 million. The Air Force plans to include the remainder in the fiscal year 1982 budget.

Vandenberg cost increases

We were not able to specifically identify the cost effects of schedule delays, but data we did obtain shows that between fiscal year 1978 and fiscal year 1981 the cost estimates for Vandenberg have increased a total of \$594 million. The 1978-82 Five Year Defense Program (FYDP) shows an estimated cost of \$789 million with a planned IOC in December 1982. The 1981-85 FYDP shows an estimated cost of \$1,383 million with a planned IOC in December 1983. These estimates do not consider the cost increases resulting from (1) underestimating the construction costs or (2) postponing the IOC from December 1983 to June 1984.

An October 1980 Air Force preliminary estimate of total costs to achieve a June 1984 IOC shows the cost of Vandenberg facilities could increase to \$1,841 million. This is an additional increase of \$458 million in the 1 year since the 1981-85 FYDP estimate of \$1,383 million. The October 1980 estimate covers the 1982-86 FYDP time frame.

SECURE COMMUNICATION NEEDS

STS missions will require communications among various ground facilities to monitor the status of the payload and orbiter and to assure necessary facilities and equipment are able to support the mission. For example, a malfunction in a payload would have to be made known to the launch control center at Kennedy as well as to the Controlled Mode 1/ at Johnson Space Center before launch. DOD has a need for secure communication links between the Controlled Mode; the launch control centers at Kennedy and Vandenberg; the Air Force Satellite Control Facility at Sunnyvale, California; and NASA's telemetry and tracking facilities at Goddard Space Flight Center in Greenbelt, Maryland.

To date, the Air Force has estimated \$123 million is required for secure communications--\$66 million for the

1/The Controlled Mode will be used for secure DOD command, control, and communications of classified space missions.

Controlled Mode at Johnson, \$38 million for modifications at Kennedy, and \$18.6 million for modifications at Sunnyvale. 1/

The need for additional secure communication links and the "work-around" solutions are being studied. Accordingly, the potential effects on operations and costs are not yet known. Nevertheless, Air Force officials identified a need for about \$14 million for a computer and associated facilities to have secure communications at Goddard Space Flight Center. They said this amount will be included in the 1982 budget. Further, the need for a new computer to process classified payload data at Kennedy is being studied. This computer, if required, is planned to be located in the launch control center and may cost between \$7 and \$15 million.

Additional risks in achieving secure communications

Another potential problem in achieving a fully capable Controlled Mode is the availability of the NASA Tracking and Data Relay Satellite System. The planned flow of STS communications between the orbiter/payload and ground facilities is through this satellite system. The NASA flight manifest shows the first of these satellites is scheduled for launch in September 1982 and the second is scheduled for launch in December 1982. Program officials estimate it could take an additional 60 to 90 days for the contractor to check out the satellite system. DOD has an operational mission scheduled for launch in April 1983.

The availability of the Tracking and Data Relay Satellite System has already been delayed from December 1980 to April 1983 as a result of development problems with the satellite and the Shuttle delays. Accordingly, program officials are concerned the NASA satellite system could encounter further delays. If a delay were to occur, work-around solutions will have to be developed which could make mission operations more difficult.

For example, an operational Tracking and Data Relay Satellite System would provide 85 to 90 percent of mission

1/The cost of modifications for the satellite control facility at Sunnyvale are in a program element other than DOD's STS program.

coverage whereas a work-around solution, such as using DOD's remote tracking sites, would only provide 15 to 20 percent of mission coverage. The limited coverage of the remote tracking sites may restrict DOD's ability to fully utilize the Shuttle capabilities during the April 1983 mission. The program office is working under the assumption the NASA satellite will be available as scheduled. However, in the event the STS first manned orbital flight is delayed or encounters problems, they will then have to begin studying work-around solutions.

CONCLUSIONS

Delays in the operational availability of STS have caused DOD to acquire additional backup ELVs and delay transitioning of two satellite programs. The acquisition of STS facilities at Vandenberg have been delayed and costs have increased substantially.

While the delays have not resulted in any known operational degradations to date, continuing uncertainties may further delay DOD's use of the full capabilities of the STS, increase costs, or degrade future planned operational capabilities.

CHAPTER 3

RISKS AND UNCERTAINTIES

AFFECTING DOD SPACE EFFORTS

Areas of risk and uncertainty exist which may delay, degrade, or limit the full use of the capabilities promised by STS and further increase costs. These areas include:

- DOD developmental problems with IUS.
- DOD delay in acquiring CSOC.
- Implementation of physical security at Kennedy Space Center and Vandenberg Air Force Base.
- Potential need for continued use of ELVs.

Details are discussed in the following sections.

UNCERTAIN AVAILABILITY OF IUS

IUS is a solid propellant rocket vehicle. It will be carried in the Shuttle payload bay and used to deploy civil and DOD satellites from the Shuttle's low Earth orbit to higher orbits. DOD is developing IUS for use by both DOD and NASA in a basic "two-stage" configuration. NASA also plans to use a "twin-stage" and a "three-stage" configuration. Also, DOD plans to use IUS on the TITAN III ELVs to improve the probability of mission success and to reduce launch costs during the early Shuttle transition period. An illustration of the various IUS configurations is on page 17 and an illustration of IUS within the Shuttle is on page 18 .

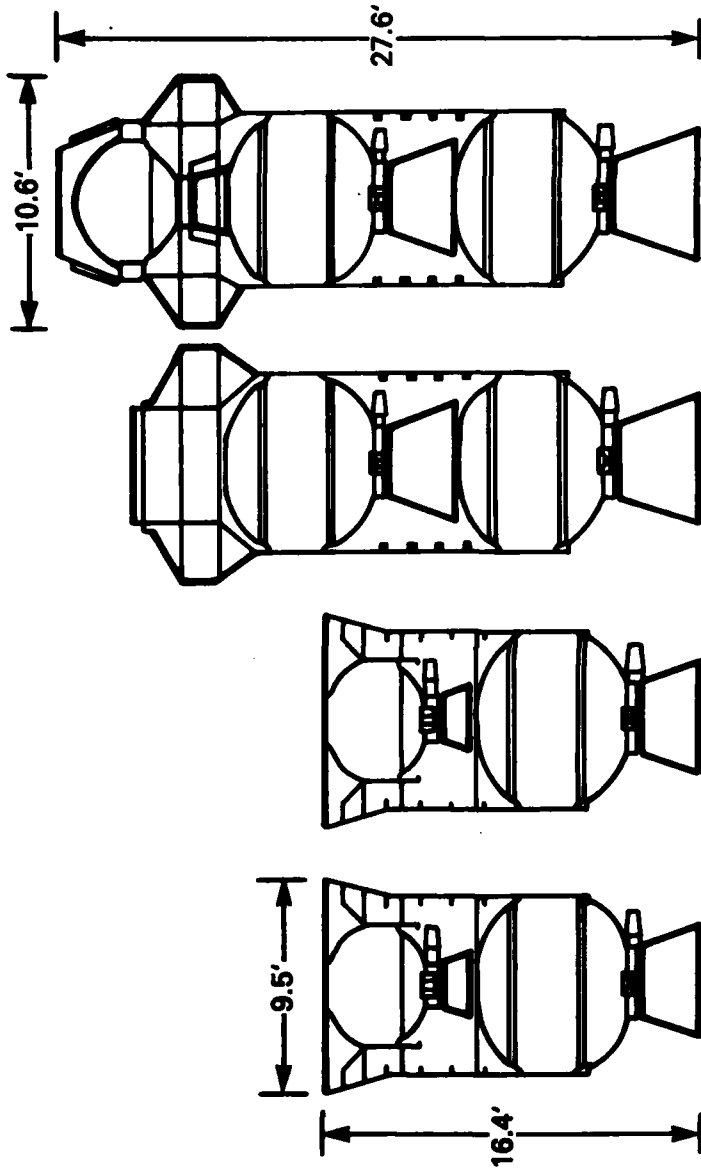

CONFIGURATION	TITAN TWO STAGE	SHUTTLE TWO STAGE	NASA TWIN STAGE	NASA THREE STAGE
PAYLOAD REQUIREMENT	4,000 LB TO GSO	5,000 LB TO GSO ^{2/}	11,464 LB TO VENUS	5,864 LB TO JUPITER
INITIAL FLIGHT CAPABILITY	1981	1981	1985	INT. SOLAR POLAR 1985 GALILEO - 1984

INERTIAL UPPER STAGE CONFIGURATIONS

^{2/} Geosynchronous orbits.

Courtesy of
BOEING AEROSPACE COMPANY

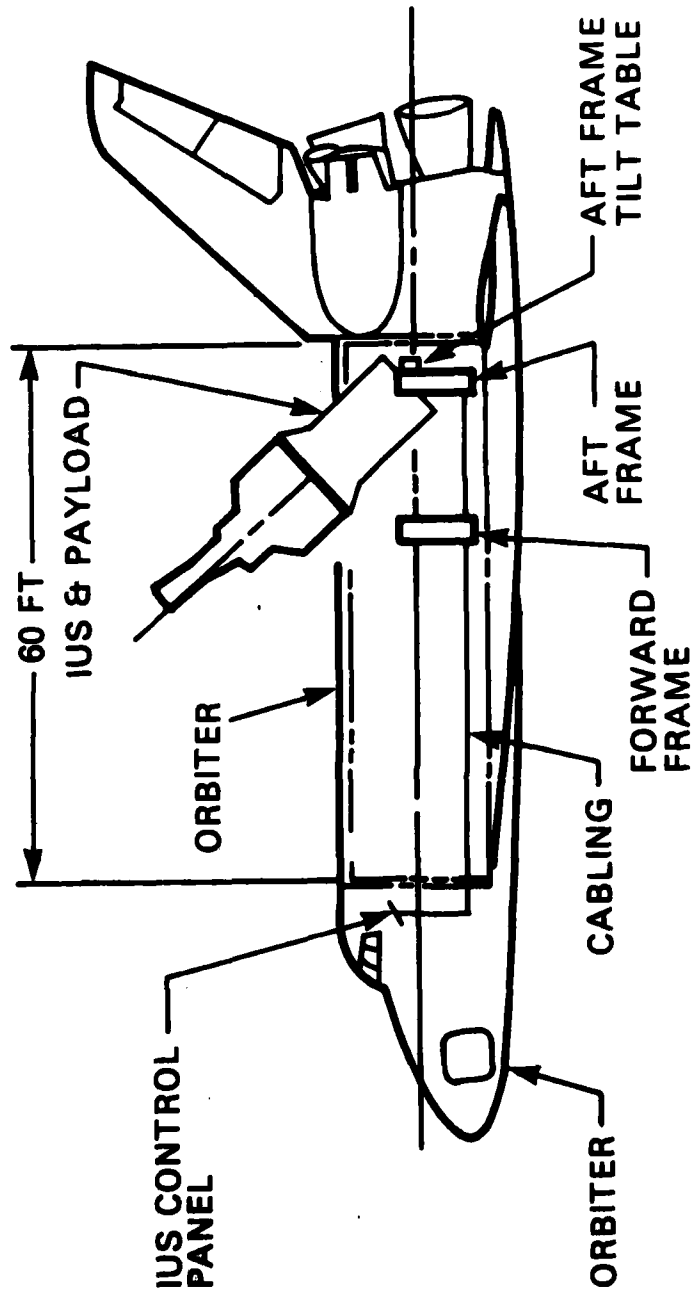

AIRBORNE SUPPORT EQUIPMENT

Courtesy of DOD

Delays in IUS availability
and cost increases

The IOC of IUS was delayed 1 year from July 1980 to July 1981. 1/ In a statement before the House Committee on Appropriations, the Air Force stated the delay was a result of underestimating the technical complexity of development efforts and inadequate management attention by the contractor and the Air Force.

These problems caused estimated costs for development of IUS to increase \$102.1 million in constant 1978 dollars. In March 1978, when IUS was approved for full-scale development, the estimated costs were \$284.5 million. In May 1980 a program office preliminary estimate indicated the costs had increased to \$386.6 million. 2/

The above estimates do not represent all costs expected to be incurred in developing IUS. Some costs are funded by the Air Force's Space Boosters Engineering Development program and some costs are funded by NASA. The lack of visibility on total DOD costs for participation in the STS program is discussed in chapter 4.

The Air Force discussed the technical, schedule, and cost problems with the House Committee on Appropriations during a request for fiscal year 1980 reprogramming authority. The problems resulted in renegotiation of the contract for development and production of nine IUSs. 3/ In April 1980, the renegotiation was completed and the contract price was increased to \$438.9 million. 4/ The renegotiation also (1) extended the delivery dates of IUSs, (2) redefined cost sharing provisions, and (3) placed a ceiling of \$462.4 million on the amount of the Government's participation in the costs of developing IUS. Notwithstanding Air Force comments to the Congress about limiting the Government's liability, the cost ceiling is not a maximum ceiling. It can increase due to modifications--to the scope of work--negotiated

1/Milestone dates for IUS are shown in appendix III.

2/In October 1980 the Air Force estimated then-year costs were \$457.6 million.

3/Five IUSs are to be used and funded by NASA.

4/Original contract was approved in April 1978 for \$248.8 million.

subsequent to the date of renegotiation. As of September 24, 1980, additional modifications had increased the contract price by about \$33 million to \$471.8 million and the contract ceiling to \$475.4 million.

Potential for future delays

In early September 1980, the Air Force reported to the House and Senate Military Construction Subcommittees that development of IUS was on schedule and would support operational launch requirements. The report was as of July 30, 1980, and stated that although IUS development would not be completed before late 1981, there was confidence the cost and schedule projections would be achieved.

In our opinion, however, IUS still has major areas of uncertainty which could delay the IOC and further increase costs. For example, the motor development efforts still are experiencing difficulties, the software will not be completely checked out until early 1982, and there is a possibility the airborne support equipment for IUS may have to be redesigned. The first two areas of concern could affect the first TITAN/IUS launch scheduled for November 1981. The third area of concern could affect the first Shuttle/IUS launch scheduled for September 1982.

Program officials said although these potential problems exist, the necessary corrective solutions have been identified. Nevertheless, program officials believe the risks are such that spring 1982 is a more realistic date for the first TITAN/IUS launch rather than the scheduled November 1981 launch.

The present design and/or location of the airborne support equipment is such that, in the event of a Shuttle/IUS mission being aborted, there is concern whether the Shuttle can return safely with an IUS and a satellite still onboard. The problem is being studied, and program officials believe relocating the airborne support equipment will be sufficient to overcome this area of concern.

If the corrective measures are not adequate, the airborne support equipment may have to be redesigned. This design effort could take about a year and would delay the first Shuttle/IUS launch scheduled for September 1982. NASA officials advised us, however, it is likely this problem can be overcome without significant effect to the current schedule.

This potential delay would also affect DOD's space programs. The first Shuttle/IUS launch is planned to carry NASA's Tracking and Data Relay Satellite System. As discussed on pages 14 and 15, the delayed availability of this satellite system would make accomplishment of DOD's space mission more difficult.

DELAYS IN DEVELOPING CSOC

In February 1980, in testimony before the House Subcommittee on Space Science and Applications, the Secretary of the Air Force said a CSOC was being developed. CSOC is planned to be located near Colorado Springs, Colorado, and will consolidate satellite operations and Shuttle planning and operations into a single center. Operational availability of CSOC, originally planned for mid-1985, has been delayed to July 1986.

Documentation at the program office indicates CSOC is needed to (1) protect national resources from natural disasters and other threats, (2) improve security of intelligence information, (3) increase operational flexibility, (4) save costs by combining functions, and (5) provide autonomous Air Force control of DOD space missions. CSOC will be the prime mission control center for DOD Shuttle and satellite operations. Facilities such as the Controlled Mode at Johnson Space Center and the Air Force Satellite Control Facility at Sunnyvale, California, will be backups to CSOC. Preliminary Air Force estimates indicate costs to achieve an operational CSOC by July 1985 will be \$538 million. Development and acquisition costs are estimated at \$403 million, while operations and maintenance costs for fiscal years 1983 through 1985 are estimated at \$135 million.

Air Force and program officials said that although they were directed to develop plans to have CSOC available by mid-1985, the efforts were inadequately funded during 1980, and accordingly, little planning work has been done. The latest program direction shows the operational availability of CSOC is now planned for July 1986 and the fiscal year 1981 budget submission contains \$13.7 million for research, development, test, and evaluation.

It should be noted that costs of acquiring CSOC are being funded under a program element separate from DOD's STS program element. DOD officials said CSOC is not considered a part of the STS program and it should not be categorized as a near-term Shuttle investment such as the Vandenberg facilities or IUS development. Since CSOC will be

developed, in part, to serve as the primary mission control center for DOD Shuttle operations, we believe that portion applicable to the Shuttle should be reflected in DOD's costs of participation in the STS program. This will improve congressional visibility into DOD's involvement in the STS program, regardless of whether the investment is near or far term. Chapter 4 provides additional information on the total costs of DOD participation in the STS program, including the cost for CSOC.

Development of CSOC is related, in part, to a decision to reduce DOD's Controlled Mode capability at Johnson from conducting two classified missions simultaneously to being able to only conduct one classified mission. ^{1/} The postponement in CSOC availability from mid-1985 to mid-1986 coupled with the reduction in Controlled Mode capabilities at Johnson have created a potential for delays or degradations in conducting two or more DOD classified missions simultaneously. This could occur in the event of (1) unforeseen launch requirements resulting from a deterioration of international affairs or a malfunction of a satellite or (2) further delays in the availability of CSOC or the Controlled Mode at Johnson. NASA, however, believes two simultaneous DOD top priority missions can be supported through the use of work-around measures such as temporarily securing the entire Mission Control Center at Johnson.

SURVIVABILITY OF STS

STS has been designated a national asset to serve both civil and defense users. It is planned to become the sole means for U.S. access to space after ELVs have been phased out in the mid- to late-1980s. Therefore, security of operational facilities, flight hardware, and support activities is essential for national security missions. STS survivability encompasses threats against the Shuttle while in orbit and against electronic, communications, and ground disruptions.

In 1978 Presidential Directive Number 37 on National Space Policy, made security of STS the responsibility of the agency in possession of the facilities and equipment. In late 1979 the Air Force developed a conceptual plan for STS ground security. Air Force officials said the

^{1/}DOD officials said this reduction in capability was in response to a congressional request to reduce the cost of the Controlled Mode.

security provided will be approximately equivalent to that presently provided at Kennedy and Vandenberg for DOD launches on ELVs. In March 1980 DOD and NASA in a revised Memorandum of Understanding on management and operations of ST' agreed to identify and implement the necessary survivability measures.

The conceptual plan was developed primarily for STS security at Vandenberg; however, program officials believe the concepts are also applicable to the Cape Canaveral Air Force Station, Florida, and the Kennedy Space Center. The plan has not yet been approved by the Air Force or NASA, but program officials believe the plan will be accepted. DOD officials stated that some time will pass before final decisions are made on the level of increased protection needed during the Shuttle operational era.

The concepts provide for the use--at various distances from the launch site--of sensors, barriers, patrolled areas, lighting, and helicopter surveillance. The security concept is depicted on pages 24 and 25.

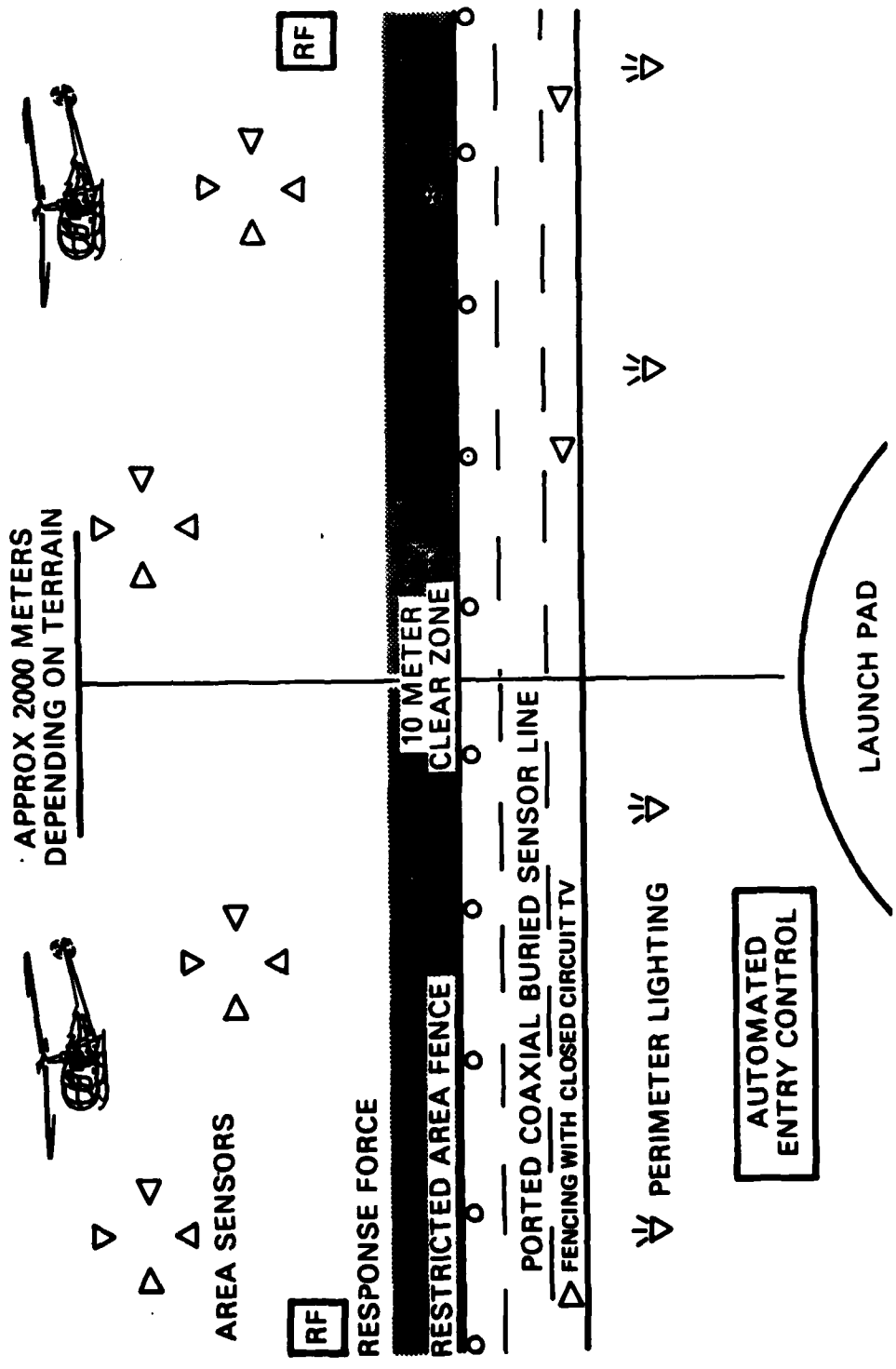

SECURITY CONCEPT

Courtesy of U.S. AIR FORCE

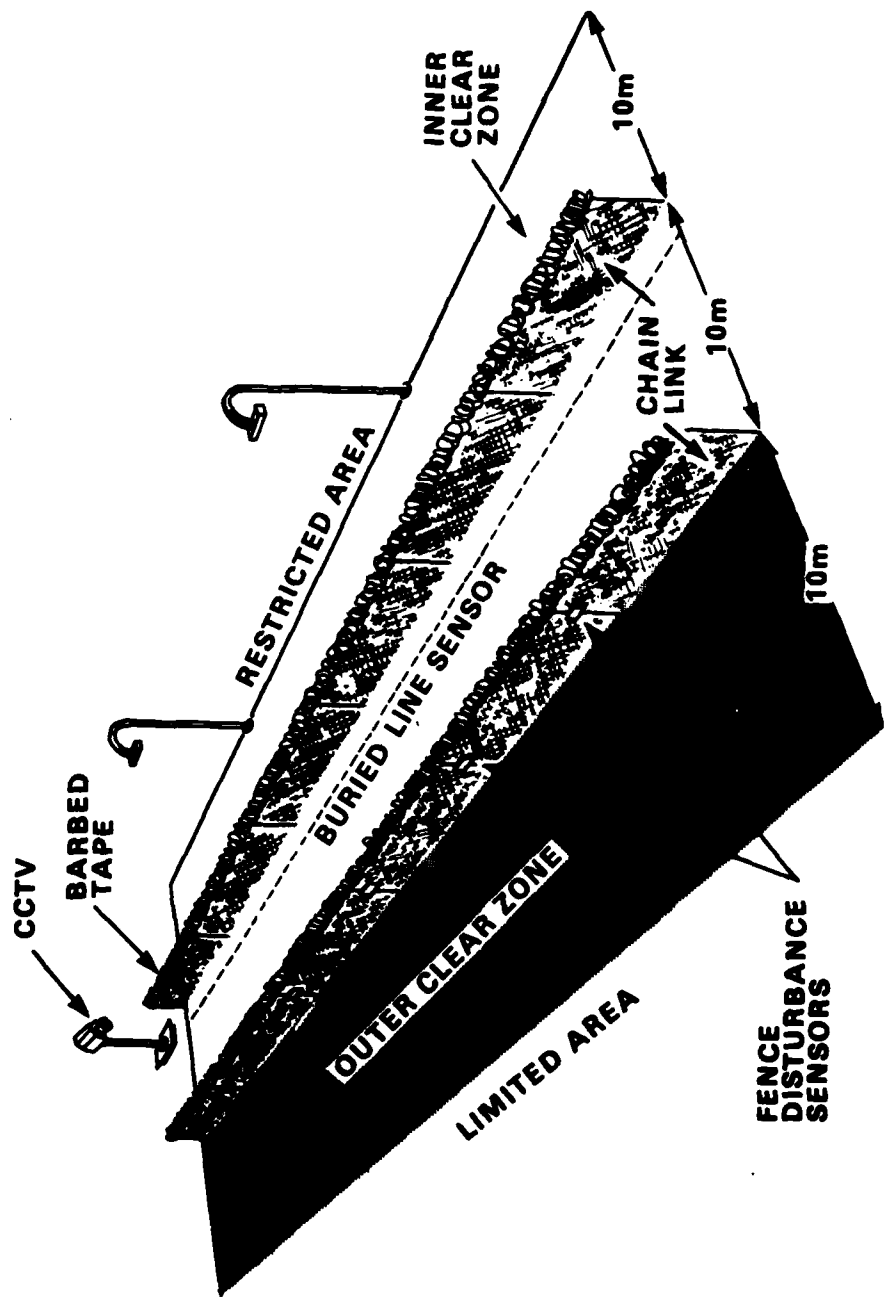

ENFORCED BARRIER SYSTEM

Courtesy of U.S. AIR FORCE

Costs to implement the security measures contemplated in the conceptual plan for Vandenberg and Cape Canaveral are estimated by Air Force and program officials to range between \$10 and \$30 million, and when defined, are planned to be included in the fiscal year 1983 budget. Program officials do not anticipate any delays in implementing STS physical security measures since the earliest need date would be September 1983 when the first orbiter is scheduled to arrive at Vandenberg.

Physical security at Kennedy was needed in December 1980 when the first orbiter was rolled out from the Vehicle Assembly Building. Program officials said that due to lack of time to implement security measures at Kennedy and NASA's budgetary constraints, the full level of physical security would not be available by that date. However, NASA is developing work-around plans until full security is in place in December 1982. These plans include limiting access to the orbiter and launch pad areas and providing extra security personnel. The costs of implementing physical security at Kennedy and the necessary work-arounds are being studied by NASA, and accordingly, were not known by Air Force program officials.

The need for STS physical security is predicated on the premise STS will be the sole means for U.S. access to space. Accordingly, if ELVs were to continue to be used as launch vehicles after the operational availability of STS, the level of STS physical security would decrease.

POTENTIAL NEED FOR CONTINUED USE
OF ELVs AND/OR MORE ORBITERS

Recent comments by the Secretary of the Air Force and top NASA officials, as well as studies by NASA and the Aerospace Corporation in El Segundo, California, indicate there may be a need for continued use of ELVs beyond the date of operational availability of the Shuttle.

A July 1980 study which was briefed to us by NASA officials stated a four-orbiter Shuttle fleet was inadequate to provide assured services beyond 1986. The study also stated there was a continued role for ELVs until adequate STS capacity was available. This study essentially evaluated STS capacity to accommodate known and projected launches and concluded a six orbiter fleet might be required. NASA officials emphasized that the study was not complete and that any finding be considered as tentative. The study was subsequently completed in November 1980, and while we have

not reviewed it, NASA officials said the conclusions have not changed substantially.

The Aerospace Corporation study was completed in April 1990 and stated the four orbiter fleet does not support the national mission model of 487 Shuttle launches. It further stated the four orbiter fleet should be adequate to fulfill all DOD launches provided DOD has priority over other users and provided the Shuttle does not have a catastrophic occurrence or the Shuttle fleet is not grounded. The study also indicated that in the event DOD has priority, NASA will not be able to meet its projected launch requirements unless at least two additional orbiters are acquired at an estimated cost of \$2 billion plus additional facilities at an undetermined cost. In the event of a catastrophic occurrence or grounding of the Shuttle fleet, DOD may have to acquire additional ELVs. Program and Aerospace Corporation officials cautioned us this study was an internal Aerospace Corporation study and does not represent the position of DOD or the Air Force.

In the fiscal year 1979 hearings before a subcommittee of the House Committee on Appropriations, NASA and DOD stated a four orbiter fleet could launch 53 missions yearly based on a 7-day workweek with two shifts per day and certain assumptions, such as length of mission duration and turnaround time. With a 5-day, two-shift workweek, the launch capability was reduced to 38 missions yearly. This information was based on the 1977 fleet size capability study done for the Office of Management and Budget (OMB) by NASA and DOD.

The Aerospace Corporation study, which was an update of the 1977 OMB study, considered the effects of contingencies, such as catastrophic loss of a Shuttle, grounding of the Shuttle fleet, an increase in turnaround time, and a 1-day increase in average mission duration. The study results show a 4 orbiter fleet capable of only 39 launches with a 7-day, two-shift workweek or 28 launches with a 5-day, two-shift workweek--71 percent and 51 percent, respectively, of the 55 annual launches currently projected for steady state operations.

Key reasons for the decrease in estimated launch capability are the increase in turnaround time at both Kennedy and Vandenberg and the increase in mission duration. Turnaround time is the length of time required to service and prepare a Shuttle and install a payload from the time it lands to the time it is ready for the next launch. In the 1977 OMB study, turnaround time was 200 and 240 hours, respectively, at Kennedy and Vandenberg. The Aerospace

Corporation study used the most current estimates of turnaround time--278 and 318 hours, respectively, for Kennedy and Vandenberg. The increase in turnaround time is the result of NASA's identification of new requirements, such as preparation of flight kits and periodic scheduled maintenance. Average planned mission duration increased from 6 days in the OMB study to 7 days in the Aerospace Corporation study.

Also, the possibility exists for further increases in turnaround time, thus increasing the probability additional ELVs will be needed. These increases in turnaround time could occur as a result of identification of new or additional requirements, such as the length of time it will take to repair 400 to 600 thermal protection system tiles after each flight. The turnaround time provides 109.5 hours for this activity, while one recent NASA analysis indicates it might take as long as 336 hours. It should be noted, however, that turnaround time projections and activities included therein are only estimates. How long it will take to perform an activity connected with servicing and preparing the Shuttle for launch will not be known until the Shuttle is flown. In commenting on our draft report, NASA officials said that since DOD uses approximately 30 percent of planned flights and has high priority, an increase in turnaround time should have a minimal effect on DOD missions.

Based on NASA and Air Force comments and studies, there is concern as to the adequacy of the four orbiter fleet to meet the launch requirements of the 487 national mission model. In fact, DOD and NASA officials said funds for long-lead items for a fifth orbiter are expected to be included in the NASA fiscal year 1982 budget. This concern focuses on the means of maintaining an assured launch capability during steady state operations--more orbiters or continued use of ELVs. The realism of the mission model as well as who should fund the additional launch capability also needs to be addressed.

CONCLUSIONS

There are areas of risk and uncertainties which have the potential to delay, degrade, or limit the full use of STS capabilities and increase costs. Further, the possibility of disruption of STS activities by overt or covert threats or a catastrophic loss of a Shuttle indicates a need to maintain an assured launch capability for both civil and defense users after the Shuttle becomes operational. The nature of this capability and how it can best be achieved is an issue for early consideration by NASA, DOD, and the Congress.

CHAPTER 4

COST OF DOD PARTICIPATION IN STS

IS INCREASING

DOD's share in the STS program cost has increased about \$1.6 billion, or about 133 percent, between fiscal year 1978 and fiscal year 1982--an average yearly increase of about \$406 million. In fiscal year 1978, the 5-year program cost estimate was \$1.2 billion. Currently, a preliminary 5-year program estimate indicates costs will increase to over \$2.8 billion by fiscal year 1982. The increase was the result of factors such as schedule delays, technical problems, cost underestimating, and inflation.

The Air Force reports costs in its program titled "DOD Space Transportation System Acquisition Activities (program elements 63411F, 64411F, and 12449F)." These activities include development and acquisition efforts for Vandenberg STS facilities, IUS, Controlled Mode at Johnson, other STS facilities at Cape Canaveral Air Force Station and Kennedy Space Center, and other efforts such as payload and program integration.

These costs do not include all costs of DOD's participation in the STS program. Other DOD-related costs appear in several programs which are reported under separate accounts. This type of reporting limits total cost and program visibility to top DOD management as well as the Congress. If all STS-related costs were considered, we estimate total costs would be about \$4 billion.

COST INCREASES IN DOD'S STS ACQUISITION PROGRAM

For the fiscal year 1981 budget hearings, the Air Force submitted a program estimate of \$2.339 billion; by October 1980, this estimate had increased by \$515 million to \$2.854 billion. Because of difficulties in obtaining information and our tight reporting deadline, we were not able to (1) assure ourselves we obtained the most current cost estimates, (2) identify specific causes for cost increases, or (3) evaluate the reasonableness of the estimates.

Presented on the following page are two tables depicting the cost growth. The first table depicts program growth since fiscal year 1978 and the second table shows major cost components of the program estimates for fiscal years 1981 and 1982.

Air Force Program Cost Estimates

<u>Budget year</u>	<u>Applicable years (note a)</u>	<u>Program estimates</u>	<u>Increase over prior years</u>
		----- (billions) -----	
1982	1982-86	<u>b/\$2.854</u>	\$.515
1981	1981-85	2.339	.360
1980	1980-84	1.979	.436
1979	1979-83	1.543	.314
1978	1978-82	1.229	-
	Total program growth--1978 to 1982		<u>\$1.625</u>
	Average yearly growth		<u>\$.406</u>

a/Includes costs of prior years' efforts.

b/Preliminary Air Force estimate as of October 1980.

Comparison of Air Force Program Estimates 1981-82

<u>Activity</u>	<u>1981</u>	<u>1982 (note a)</u>	<u>Increase</u>
		----- (billions) -----	
Vandenberg Air Force Base	\$1.383	\$1.841	\$.458
IUS	.455	.458	.003
Operations capability development:			
Payload integration	.151	.167	.016
Program integration	.131	.139	.008
Common mission operations	.074		
Johnson Space Center	.057		
Kennedy Space Center	.038	<u>b/.250</u>	.031
Cape Canaveral Air Force Station	.033	-	-
Miscellaneous	.017	-	-
Total	<u>\$2.339</u>	<u>c/\$2.854</u>	<u>c/\$.515</u>

a/Preliminary Air Force estimate as of October 1980.

b/Details not provided by Air Force in comparable format.

c/Will not foot due to rounding.

VISIBILITY NEEDED INTO
TOTAL DOD COSTS FOR STS EFFORTS

We estimate total costs of DOD's participation in developing and acquiring a STS operational capability to be about \$1 billion greater than the \$2.9 billion shown under the Air Force program titled "DOD Space Transportation System Acquisition Activities." The difference is because some development and acquisition efforts necessary for DOD to have an operational STS capability are funded under other DOD programs. For example, development and acquisition of backup ELVs are funded under the Space Boosters Engineering Development Program and some IUS acquisition and transition efforts are funded by satellite programs such as the Defense Satellite Communications System.

Following are two tables showing these additional costs. The first table identifies the programs under which various STS activities are funded. The second table breaks out these costs by functional activity.

Summary of DOD
STS Costs by Program

<u>Program title</u>	<u>Program element number</u>	<u>Amount</u> (millions)
Navy Navigation Satellite System	11221N	\$ 35.0
Defense Support Program	12431F	102.0
Defense Satellite Communications System	33110F	74.2
Special Activities	34111F	Not available
Space Boosters Engineering Development	35119F	300.3
Consolidated Space Operations Center	35130F	<u>a/538.0</u>
Air Force Satellite Control Facility Improvements and Modernization	35110F	<u>18.6</u>
Total--STS costs funded by other DOD programs		<u>1,068.1</u>
DOD Space Transportation System Acquisition Activities	12449F 63411F 64411F	<u>2,854.4</u>
Total DOD STS costs		<u>\$3,922.5</u>

a/The Air Force does not consider these costs to be part of the STS program. (See pp. 21 and 22.)

Total DOD Costs
of STS Efforts

<u>Functional activity</u>	<u>Program element</u>	<u>Amount</u>	<u>Date of estimate</u>
		(millions)	
T34D/IUS development, initial production, and operations:			
Defense Satellite Communications System	33110F	\$ 34.6	5/80
Special Activities	34111F	Not available	
Space Boosters Engineering Development	35119F	60.2	5/80
Shuttle backup boosters and production phaseout:			
Space Boosters Engineering Development	35119F	240.1	1/80
ELV to T34D/IUS transition:			
Defense Support Program	12431F	13.9	1/79
Defense Satellite Communications System	33110F	25.3	1/79
Satellite to STS transition:			
Navy Navigation Satellite System	11221N	35.0	1/79
Defense Support Program	12431F	88.1	1/79
Defense Satellite Communications System	33110F	14.3	1/79
Consolidated Space Operations Center development and acquisition:			
Consolidated Space Operations Center	35130F	a/538.0	1/80
Air Force Satellite Control Facility support of STS:			
Air Force Satellite Control Facility Improvements and Modernization	35110F	<u>18.6</u>	7/80
Total--STS costs funded by other DOD programs		<u>1,068.1</u>	
STS development and acquisition:			
DOD Space Transportation	12449F		
System Acquisition	63411F		
Activities	64411F	<u>2,854.4</u>	10/80
Total DOD STS costs		<u>\$3,922.5</u>	

a/The Air Force does not consider these costs to be part of the STS program. (See pp. 21 and 22.)

Also, as previously discussed (see pp. 7, 10, 14, and 26), matters currently under study could increase DOD costs as much as \$578 million, as shown below.

Potential Cost Increases

	<u>Amount</u> (millions)
Develop TITAN/CENTAUR capability	\$250
Additional backup ELVs	237
Develop new fairing	60
Secure communications computer--Goddard	14
STS physical security	10
Classified payload computer--Kennedy	<u>7</u>
Total	<u>\$578</u>

CONCLUSIONS

DOD costs for developing and acquiring its portion of the STS program have increased significantly since 1978, and due to program uncertainties, the potential exists for further significant increases. Further, visibility over total costs of DOD's participation in the STS program is limited. Nowhere are all costs reported in one place.

CHAPTER 5

CONCLUSIONS AND RECOMMENDATIONS

CONCLUSIONS

Identification of new requirements, funding constraints, DOD difficulties in developing IUS, and NASA delays in developing STS have had the following effects on DOD participation in the STS program:

- Costs have increased substantially--\$1.6 billion, or about 133 percent--between fiscal years 1978 and 1982.
- More ELVs have been required.
- Transitioning of satellite programs from ELVs to the STS has been delayed, which in one case delayed the introduction of a more capable satellite.

To date, the operational availability of STS has been delayed 3-1/2 years. DOD officials stated that the STS delays have not resulted in any known operational degradations, and if current schedules are met, there should be no adverse mission effects to DOD space programs. Continuing uncertainties, however, may further delay DOD's use of the full capabilities offered by STS, increase costs, or degrade future DOD operational capabilities in space.

Recent Air Force and NASA studies indicate additional ELVs and/or orbiters may be required. In fact, we were advised that funds for long-lead items for a fifth orbiter are expected to be included in the NASA fiscal year 1982 budget.

Visibility into DOD costs of STS activities is limited because the DOD Space Transportation System Acquisition Activities Program does not reflect total costs to achieve an operational STS capability. Some significant costs are funded by individual satellite and other programs.

In view of past problems with STS, continuing uncertainties, and the lack of operational experience with the system, it is essential that the Congress have a comprehensive understanding of the options available for meeting launch requirements--particularly critical DOD requirements.

RECOMMENDATIONS

We recommend that the Secretary of Defense and the NASA Administrator provide the Congress with comprehensive information on the options being considered for maintaining an assured launch capability for defense and civil missions and the key assumptions, costs, and risks associated with each option. In addition to an analysis of the advantages and disadvantages of the continuing use of ELVs and/or increasing the number of orbiters, the information should include an identification of all known and projected critical and noncritical missions. Information should also be provided on the probable effects of canceling or delaying some noncritical flights until operational experience with STS is obtained.

We also recommend that the Secretary of Defense provide the Congress information on the total probable DOD funding requirements to achieve an operational STS capability, including STS-related costs funded by individual satellite and other programs.

AGENCY COMMENTS

Because of tight reporting deadlines, we did not request official comments on this report. Instead, a draft of the report was discussed with high level DOD and NASA officials associated with management of the program and changes were made to the report, where appropriate, to reflect specific comments.

Though not solicited, NASA provided written comments on the draft report. (See app. II.)

While NASA agreed STS has been delayed, NASA believed the report title and conclusions were misleading because a reader could infer the delays were directly responsible for (1) DOD delays in activating STS facilities at Vandenberg, (2) degradation of DOD mission capabilities, and (3) growth in the cost of DOD's participation in the STS program. We did not intend to imply that DOD difficulties were due solely to NASA delays. Accordingly, the report title and conclusions were revised to clarify our view that NASA delays contributed to DOD difficulties with the program.

The draft report pointed out that there have been delays in the availability of the Controlled Mode at Johnson Space Center and discussed the potential impact of these delays on DOD's ability to provide secure communications for a mission scheduled for April 1982. NASA and DOD advised us that subsequent to completion of our fieldwork, the Congress canceled

this mission. Therefore, according to NASA there is no longer a need for this capability in April 1982. The first DOD secure mission is now scheduled for April 1983, and NASA stated the current schedule will meet this requirement. Accordingly, we deleted this matter from our final report.

NASA agreed with our recommendation that the Congress should be comprehensively informed of the options and underlying assumptions and factors being considered to maintain an assured launch capability. NASA stated that this recommendation implies that the Congress has not been informed of these issues in the past--which in NASA's opinion is not correct. NASA suggested our recommendation would be more appropriate if it were to state that NASA should continue to inform the Congress of the STS program status as it relates to assured launch capability. We did not change the recommendation because we do not believe that NASA and DOD have presented in a comprehensive manner how an assured launch capability will be maintained.

Other NASA comments related to new information or matters of clarity have been included in appropriate sections of the report.

OUR PREVIOUS STS REPORTS

<u>Report title</u>	<u>Report number</u>	<u>Report date</u>
Cost Benefit Analysis Used in Support of the Space Shuttle Program	B-173677	6/2/72
Analysis of Cost Estimates for the Shuttle and Two Alternate Programs	B-173677	6/1/73
Space Transportation System Staff Study	Staff study	6/74
Space Transportation System Staff Study	Staff study	2/75
Status and Issues Relating to the Space Transportation System	PSAD-76-73	4/21/76
Space Shuttle Facility Program: More Definitive Cost Information Needed	PSAD-77-17	5/9/77
Space Transportation System: Past, Present, Future	PSAD-77-113	5/27/77
Letter report on DOD Construction Program for Facilities to Support the Space Transportation System at Vandenberg Air Force Base	PSAD-77-109	6/2/77
A Second Launch Site for the Shuttle? An Analysis of Needs for the Nation's Space Program	PSAD-78-57	8/4/78
Letter report on NASA's Supplemental Request of \$185 million for the Space Shuttle Program	PSAD-79-59	3/16/79



National Aeronautics and
Space Administration

Washington, D.C.
20546

Reply to Attn of L

DEC 31 1987

Mr. W.H. Sheley, Jr.
Acting Director
Procurement and Systems
Acquisition Division
U.S. General Accounting Office
441 G Street, N.W.
Washington, DC 20548

Dear Mr. Sheley:

As requested, we have reviewed GAO's draft report entitled, "STS Delays Have Adversely Affected DOD's Space Programs" and our major comments are attached. In addition to these specific comments, however, I would like to emphasize that several of the conclusions relative to adverse impacts of STS delays on DOD programs are in error, that a number of the other conclusions are overstated, and that even the title is misleading in inference and not descriptive of the scope of the study.

While it is true that the STS has been delayed two and a half years from its schedule established in 1974, it is not at all evident, nor does the draft report substantiate, that this delay is also directly responsible for DOD cost growths, degradation of defense mission capability, or hold-up in the activation of the Vandenberg IOC as inferred in the report's digest and conclusions. Most of the Shuttle delays were accounted for in the DOD planning, and we have been on schedule to support the DOD operational missions requested and are not aware of any slip in the Shuttle that has adversely impacted DOD operational space systems. Specifically, Vandenberg IOC delays, although made possible by Shuttle delays, were not caused by them, but resulted from budgetary decisions based on the deferred need for a west coast launch site.

Although our comments cite particular areas that are either factually in error or misleading, we strongly recommend that an overall rewriting of the report be undertaken which accurately couples facts with conclusions so that an objective, useful report can result.

Sincerely,

Gerald D. Griffin
Acting Associate Administrator
for External Relations

Attachment

APPENDIX II

APPENDIX II

cc:
Mr. Howard Barfield
Staff Specialist, Advanced &
Space Systems
OUSDRE (O&SS)
Pentagon
Washington, DC 20301

HQ USAF/RDSL
Attn: Lt Col Jacoby
Washington, DC 20330

December 23, 1980

NASA COMMENTS ON THE COMPTROLLER GENERAL
DRAFT REPORT TO THE CONGRESS TITLED
"STS DELAYS HAVE ADVERSELY AFFECTED DOD SPACE PROGRAMS"

GENERAL COMMENTS

- a. The report's conclusion that NASA's shuttle delays in Initial Operational Capability (IOC) have been a major cause for Vandenberg Air Force Base (VAFB) facilities to slip and DOD costs to increase is not substantiated. The NASA and DOD positions are that the VAFB IOC was based on DOD payload requirements and not on Shuttle IOC. Further, because the report does not give any specifics regarding the impact of Shuttle delays as they relate to the magnitude of DOD cost increases, NASA takes exception to the causality implied in the report tying Shuttle schedule slip to some \$1.7 billion DOD cost growth.
- b. The title of this draft GAO report is misleading in that it infers that the DOD space capabilities have been degraded as a result of NASA delays. We are not aware of any degradation in DOD operational space capabilities. In fact, the conclusion stated in the report title is inconsistent with the conclusion reached in Chapter 5, page 60, of the report that "...delay in operational availability of the STS has not caused any serious degradation in United States space capabilities". Based on the data presented in the report it is suggested that the title be changed to reflect the general topic of discussion rather than a subjective and misleading conclusion.
- c. The scope of the audit is different than that implied in the title. The major portion of the report does not pertain to the impact of NASA-related SIs delays on overall DOD space programs, but rather primarily involves the status and cost of these STS elements for which DOD has responsibility, DOD plans for transitioning from expendable launch vehicles to STS and concern for an assured launch capability after STS becomes operational.

EXCEPTIONS TO GAO CONCLUSIONS (CHAPTER 5)

The lead in paragraph to the GAO conclusions is extremely misleading in that it does not identify the causes of the adverse effects identified. It is strongly recommended that the report be reviewed and rewritten to clarify and document each area in which cause and effect relationships are implied. Many factors impact cost and schedule during complex "state of the art" development projects, particularly when the unique joint requirements, schedules and budgetary constraints of two different agencies have to be managed.

- a. GAO Conclusion - STS delays have resulted in delays in the operational availability of STS facilities such as the Launch and Landing site at VAFB and the controlled mode at Johnson Space Center (JSC).

NASA Comment - The schedule at VAFB and at JSC meet all known and requested DOD mission requirements.
- b. GAO Conclusion - STS delays have resulted in the need for more backup expendable launch vehicles than originally planned.

NASA Comment - Additional expendables have been procured in order to maintain production capabilities during the period of transition to the STS.
- c. GAO Conclusion - STS delays have resulted in delays and possible degradation of certain DOD functions and missions, such as delays in the transitioning of satellite programs to the STS.

NASA Comment - There have been delays in transitioning of some missions to the Shuttle but NASA is not aware of any degradation in DOD mission capability.
- d. GAO Conclusion - STS delays have resulted in potential developmental difficulties with the Inertial Upper Stage (IUS) and may cause a further delay in its availability.

NASA Comment - There have been difficulties with the IUS, but these were not the result of delays in the NASA STS. IUS schedules support all current mission requirements.
- e. GAO Conclusion - STS delays have resulted in the need for a Consolidated Space Operations Center (CSOC).

NASA Comment - Since CSOC is not an STS requirement, it is not appropriate to include it in discussions of "adverse effects".
- f. GAO Conclusion - STS delays have resulted in the need for survivability of STS assets on the ground and in space.

NASA Comment - STS delays have no impact on STS survivability requirements.

EXCEPTIONS TO GAO RECOMMENDATIONS (CHAPTER 5)

- a. GAO Recommendation - Congress requires the Secretary of Defense and the NASA Administrator to inform it as to how an assured launch capability can be maintained.

NASA Comment - Assured launch capability is a concern shared by NASA and DOD. We are continuing to assess launch vehicle requirements to insure launch requirements can be met. The inference of this GAO recommendation is that Congress has not been informed of these issues. This is not true. Specifically, there have been discussions with the Executive Branch and with Congress on the potential need for additional orbiters in the national fleet. In NASA's FY 1982 budget, funds are requested to procure long lead items required to maintain the capability to build a fifth orbiter. The GAO recommendation would be more appropriate if it were to continue to inform Congress of STS program status as it relates to assured launch capability.

SPECIFIC COMMENTS

Cover

Summary Line 6 - Delete period after word "growth" and add words "in STS projects for which DOD has primary responsibility."

Rationale - Clarifies specific area of cost growth.

Cover

Summary Last Paragraph - Delete the current paragraph and insert recommendations as stated on page viii of the Digest or page 62 of the draft report.

Rationale - The recommendations in the cover summary are not consistent with recommendations listed on page viii or on page 62, either in number or to whom they are directed.

Page i

First Paragraph - Since the relationship between delays in Shuttle IOC and DOD cost growth, as stated in subject to conjecture, it is recommended that only those causal effects that can be substantiated by GAO be cited.

Last Paragraph - NASA does not believe that delays in Shuttle IOC have caused DOD to delay activation of VAFB. The VAFB IOC schedule is related to DOD mission requirements, not to STS IOC schedules.

- Page iii Last Paragraph - The allegation that the delay in IOC for Controlled Mode will adversely affect DOD's ability to support classified missions, and that this delay was caused by NASA delays in Mission Operations Center construction, is incorrect. The first secure DOD mission was originally scheduled for April 1982 and is now scheduled for April 1983. The NASA Mission Operations Center and DOD Controlled Mode schedules safely support both of these requirements.
- Page iv First Paragraph - The statement "the Controlled Mode is dependent upon availability of the NASA Tracking and Data Relay Satellite System" (TDRSS) is incorrect. While a delay in operational availability of TDRSS could potentially limit utilizing full capability of the Shuttle, effective work arounds will allow the remote tracking stations to safely support either the April 1982 or the April 1983 secured mission.
- Last Paragraph - The CSOC is not considered to be part of the STS system.
- Last Paragraph - Current manifest planning is based on a 280 hour turnaround at KSC and 306 hours at VAFB. Since DOD uses approximately 30 percent of planned flights and has high priority, increased turnaround times should have a minimal impact on DOD missions.
- Page vii Conclusions - See comments to GAO Conclusions.
- Page viii Recommendations - See comments to GAO Recommendations.
- Page 1 Last Paragraph - Solid Rocket Motors are not pushing the "state of the art". They are almost identical to the Titan III of which more than 100 have flown without a failure.
- Page 10 First Paragraph - NASA IOC delay was not responsible for the changes in VAFB IOC or the secure mode of operations at JSC and other locations. DOD schedules are based on their mission requirements.
- Second Paragraph - The implication left to the reader is that a \$1.7 billion cost increase is attributable to a 3 1/2 year Shuttle schedule delay. This is extremely misleading. This report and other studies do not document how delays in STS IOC have caused increased cost to DOD space programs. Both DOD and NASA agree that the STS IOC delay has not adversely affected their operational mission.

- Page 11 Last Paragraph - As previously stated, the delays in VAFB IOC are only partly related to delays in STS IOC. VAFB IOC was not delayed recently as a result of delays in delivery of Orbiter 103. The delivery of 103 supports DOD mission requirements.
- Page 12 First Paragraph - VAFB IOC was not slipped due to delays in Orbiter 103 delivery. The requirement for performance augmentation was identified during the VAFB design phase. We are not aware this was cause of major delay in VAFB IOC.
- Page 13 Second Paragraph - Same as the performance augmentation comment on page 12.
- Last Paragraph - Alternative performance augmentation concepts are currently being studied. The current plan is that performance augmentation is not required before 1986. The increase in Shuttle payload capability will depend on the performance augmentation concept chosen.
- Page 14 First Paragraph - The statement, "the need for a thrust augmented Shuttle was for the first VAFB launch of Spacelab," is incorrect. The requirement to increase the Western Test Range (WTR) payload capability by 8,000 pounds is to satisfy the Performance Reference Mission 4 requirement of 32,000 pounds deployed and 25,000 pounds retrieved at 150 NM circular and 98 degree inclination on a 4 man, 7 day mission. This requirement encompasses all known, projected civil and military needs during the current mission model period.
- Page 15 First Line - This sentence should be changed to read: This event was scheduled by NASA for November 23, 1980 and did occur on November 24, 1980.
- Page 17 Second Paragraph - This is not correct. The first DOD secure mission is scheduled for April 1983 and NASA will support this. The IOC of the Controlled Mode was not delayed due to the delay by NASA of completion of the Mission Operations Center.
- Last Paragraph - The April 1982 mission has been deleted.
- Page 18 Second Paragraph - The JSC controlled mode capabilities were reduced as a direct response to a reduction in the DOD's requirements. The entire DOD payload traffic model projection for all future years shown in the current flight assignment baseline can be accommodated within the planned controlled mode capability and does not require more than one classified mission to be conducted at a time from the JSC MCC. An unforeseen top priority DOD requirement for two simultaneous missions could be accommodated by temporary securing of the entire MCC complex, if necessary, or by judicious scheduling of real-time support.

- Page 19 Top of Page - "Malfunction in the Controlled Mode" is not a meaningful term. The Controlled Mode is a combination of equipment built to satisfy secure requirements, procedures for operations, and trained personnel. The equipment malfunctions are unlikely because of the built-in redundancy, but the procedures and training will be designed to prevent a breach of security in any event. Having satisfied the DOD requirements, the Controlled Mode can ensure mission security for all payloads in the DOD model.
- Page 21 Second Paragraph - See comments regarding page iv.
- Page 30 Last Paragraph - NASA does not believe that this report properly quantifies the way in which NASA delays have adversely affected DOD space programs. If such conclusions are included, it should be acknowledged that they are subjective rather than based on the data in the report.
- Page 33 The payload requirement for the Jupiter mission under NASA's three stages should read 5,864 pounds.
- Page 38 Second Paragraph - It is likely that solutions to the Shuttle/IUS abort problem can be achieved without significant impact to the current schedule.
- Page 40 Last Paragraph - The DOD's development of a CSOC is based on the justification given on page 39 of the report and was not driven by a reduction in JSC MCC Controlled Mode capability from two simultaneous missions to one classified mission. The reduction in DOD requirements on the JSC MCC was discussed previously and it has been pointed out that the JSC MCC Controlled Mode can handle the entire DOD payload model.
- Page 49 Last Paragraph - See comments to page vi on turnaround times. The thermal protection tile replacement planning is approximately correct. Even if this requirement should increase, it can be accomplished in parallel with other activity and would not necessarily impact total turnaround time.
- Page 50 Second Paragraph - Funds are being requested in the FY 1982 budget to begin procuring long lead items in order to maintain the capability to build a fifth orbiter.
- GAO note: Page references in this appendix refer to the draft report and do not necessarily agree with the page numbers in the final report.

KEY MILESTONE DATES

<u>Milestone</u>	<u>Original schedule</u>	<u>Current estimate</u>	<u>Delay (months)</u>
Kennedy Space Center:			
First manned orbital flight	3/78	3/81	36
IOC	3/79	9/82	42
First DOD operational launch	7/80	4/83	34
Full operating capability	Not available	3/85	-
Johnson Space Center:			
Controlled Mode IOC	12/81	3/82	3
Controlled Mode full operating capability	12/82	12/82	-
Vandenberg Air Force Base:			
First delivery of orbiter	3/82	9/83	18
IOC	12/82	6/84	18
First DOD operational launch	FY 83	10/84	13-24
Full operating capability	12/82	7/86	43
First thrust augmented launch	6/85	8/86	14
IUS:			
IOC--TITAN	7/80	7/81	12
IOC--Shuttle	7/80	9/81	14
First operational launch on TITAN	7/80	11/81	16
First operational launch on Shuttle	7/80	9/82	26
CSOC:			
IOC	7/85	7/86	12