

AD-A096 315

ROYAL AIRCRAFT ESTABLISHMENT FARNBOROUGH (ENGLAND)
HUMAN REACTION TO LOW FREQUENCY MOTION - PRELIMINARY STUDIES. (U)

F/6 6/19

NOV 80 S H DU ROSS

UNCLASSIFIED

RAE-TM-FS-365

DRIC-BR-77320

NL

1 of 1
FOIA
b7E



END
DATE
FILMED
A-81
DTIC

UNLIMITED

BR77320

TECH MEMO ✓
FS 365

TECH MEMO
FS 365

LEVEL



AD A 096315

ROYAL AIRCRAFT ESTABLISHMENT

HUMAN REACTION TO LOW FREQUENCY MOTION - PRELIMINARY STUDIES

by

S. H. du Ross

November 1980

ERIC
ELECTE
MAR 16 1981
S D

FILE COPY

(11) PAL-1. A-13-365

(12) D. I.

(19) LR-77324

ROYAL AIRCRAFT ESTABLISHMENT

(7) Technical Memorandum FS 365

Received for printing 10 November 1980

(6) HUMAN REACTION TO LOW FREQUENCY MOTION - PRELIMINARY STUDIES.

by

(1) S. H. du Ross

(12) 4

SUMMARY

A preliminary experiment using the Warren Spring Laboratory ship motion simulator to ascertain the effects of low frequency ship and sinusoidal motion on man and his performance is described. The ship motion signals were based on those recorded from HMS Avenger at 25 kn into a force 4 wind. Sinusoidal motion was in heave, pitch and roll for frequencies from 0.1-0.4 Hz.

A tracing task involving unsupported arm movements was seriously affected by the motion; a tracking task showed a small decrement in performance and a digit keying task was unaffected. There was no evidence that adverse effects were caused by motion sickness. Accelerations were measured at the head and hand of each subject and compared to the input accelerations. The resulting transmissibilities showed that relatively large rotational motions could be induced.

The simulator required extensive modifications to its mechanical hydraulic and electronic systems in order that it could safely be used for human subjects. Notwithstanding these modifications the simulator exhibited undesirable cross-axis movements which may have a bearing on the results. The experiment also showed that more sophisticated measurements were necessary to accurately describe resulting biodynamic behaviour.

Copyright ©

Controller HMSO London
1980

Handwritten signatures and marks at the bottom of the page.

LIST OF CONTENTS

	<u>Page</u>
1 INTRODUCTION AND OBJECTIVES	3
1.1 Introduction	3
1.2 Objectives	3
2 APPARATUS	4
2.1 Simulator	4
2.2 Measuring equipment	4
3 EXPERIMENTAL DESIGN - INTRODUCTION	7
3.1 Tracking task	8
3.2 Head transmissibility measurements	9
3.3 Hand transmissibility	9
3.4 Keyboard task	10
3.5 Track tracing task	10
3.6 Subjective ratings	10
4 RESULTS	10
4.1 Rotational acceleration measurements	10
4.2 Keyboard operation under ship motion	12
4.3 Tracking task	13
4.4 Track tracing task	13
4.5 Questionnaire	14
5 DISCUSSION AND CONCLUSIONS	14
5.1 Simulator response	14
5.2 Rotary acceleration measurements	14
5.3 Head transmissibility	15
5.4 Hand transmissibility	15
5.5 Keyboard task	15
5.6 Tracking task	15
5.7 Track tracing task	16
5.8 Recommendations	16
Acknowledgments	16
Appendix A Description of the Warren Springs simulator and the modifications required for this experiment	17
Illustration - Figure A1	19
Appendix B Analysis of heave motion	20
Appendix C Errors in the use of linear accelerometers when rotated	22
Illustrations - Figures C1&C2	23
References	24
Illustrations	Figures 1-19
Report documentation page	inside back cover

1 INTRODUCTION AND OBJECTIVES

1.1 Introduction

This is a report of a joint experiment between the Human Engineering Division (FS4) of the RAE and the Applied Psychology Unit (APU) of the MRC and funded by SP(N) MOD. It was required to determine the effects of low frequency ship and sinusoidal motion on subject performance using previously acquired skills including a simulated weapon aiming task, manual dexterity tasks, together with measurements of transmissibility to the head and hand. The transmissibility was required as the response of the head and hand at frequencies below 1 Hz was unknown.

This was the first trial of its kind in the UK and probably in Europe and as such was of a preliminary nature. It was considered important to conduct such experiments because more and more sophisticated psychomotor tasks are being employed in RN ships. In addition the results could apply in principle to aircrew performance under similar low frequency motion which occurs in turbulence and in high speed low level flight. Fig 1 shows the acceleration waveform and the derived velocity and displacement waveforms for a Canberra travelling at 400 kn at 150 ft.

The RN, RAF and MOD(PE) considered it important to get an assessment of the problems of experimentation in this unexplained area and also of the problems of rig operation and design. (A new low frequency simulator has been under consideration by the RAE for some time.)

The author's contribution concerned the acquisition and development of equipment and of ship motion recordings, assistance in man rating the rig, the determination of effects of ship and sinusoidal motion upon transmissibility and the effects of ship motion on a simple keyboard task. Details of the APU experiments on tracking (simulated weapon aiming) and tracing tasks (manual dexterity) are given elsewhere¹ but for completeness, are summarised in this Memorandum.

A literature search, made by SP(N) showed that very little objective research had been done into effects of ship motion upon performance although the field of motion sickness had been well covered². In this experiment it was proposed only to measure performance and transmissibility under low frequency motion, without encroaching into the area of nausea and vomiting and for this purpose the ten subjects were chosen to be either not susceptible to motion sickness or of mild susceptibility, easily allayed by small amounts of Hyoscine.

1.2 Objectives

The primary objectives of the experiment were:

- (i) To study the effects of ship motion on a simulated weapon aiming task (APU).
- (ii) To measure the transmissibility of acceleration from the platform to the subject's head and hand during ship motion (3 axis) and during discrete sinusoidal motion (RAE).
- (iii) To determine whether ship motion affected a simple keyboard task (RAE).

(iv) To determine whether ship motion affected a simple task of tracing shapes pinned to the cabin wall (APU).

(v) Application of a short questionnaire on nausea (APU).

Secondary objectives were:

(i) To analyse the motion of the simulator to highlight problems that could be prevented in the design of a simulator for the RAE (RAE).

(ii) To obtain operational experience and experimental design guidelines relating to the use of this type of simulator (RAE).

(iii) To determine the 'sensitivity' of the performance measures to this sort of motion (RAE).

(iv) To improve instrument design for low frequency work (RAE).

This Memorandum describes the uprating of the rig, the basic experiments, subsequent analysis and instrumentation problems highlighted by the experiment.

2 APPARATUS

2.1 Simulator

The basic equipment used was the ship motion simulator at the Department of Industry's Warren Spring Laboratory (WSL) at Stevenage. This device is probably the most sophisticated in Europe, capable of providing multi-axes simulation of ship motion. The basic parameters of the simulator are:

(i) Heave ± 1.85 m.

(ii) Roll $\pm 8^\circ$.

(iii) Pitch $\pm 8^\circ$.

(iv) Payload 1 tonne.

(v) Frequency range 0.05-0.5 Hz (dependent on acceleration required).

The equipment was primarily designed³ to determine the effects of ship motion on semi-solid cargoes and for this experiment had to be extensively modified to strengthen certain parts and to make it suitable for safe operation with human subjects (Appendix A).

A cabin measuring 1.8m x 2.4m x 2.1m high was designed and built by WSL and a console, seating, instrumentation etc were installed by RAE (Figs 2 to 4).

2.2 Measuring equipment

2.2.1 A diagram of the equipment used to measure transmissibility, assess rig performance, drive the simulator, present tasks to the subject and measure his response is shown in Fig 5.

2.2.2 Accelerometer measurements

Accelerations at the hand were obtained by three miniature linear accelerometers (Entran Type EGAL 125-10) taped to the forefinger knuckle of the subject's right hand. Each accelerometer measured 4 mm x 4 mm x 8 mm and the total weight of the accelerometers

mounted in a block was only 3 g. These are the smallest accelerometers known to the author and their mass was considered to have minimal effect on transmissibility.

Accelerations transmitted to the head were measured using another three miniature linear accelerometers (as above) mounted on to a bite bar containing three rotary accelerometers (Schaevitz ASMP-50) to produce a 6-axis system. The rotary accelerometers were the smallest known but even so the total mass of the bite bar came to approximately 400 g. This mass is fairly high and although it was considered to possibly affect head motion a lighter system was not available.

Accelerations of the platform were measured using one linear and two rotary accelerometers of the type mentioned above. These were mounted on the floor of the cabin in line with the rotary axis but displaced 300 mm above it. True vertical acceleration could be derived using the rotary accelerations and angular position but as the angles and rotary accelerations were relatively small (\sin^2 and $\cos^2 < 1\%$; $\pm 0.2 \text{ rad/s}^2$) their effect on the heave acceleration was considered low enough to be ignored in this preliminary experiment. The overall transmissibilities were computed by comparing the input accelerations to the man with the accelerations at the hand and head. This was done by taking the fast Fourier transforms of the input and output and computing their ratio within the frequency band of interest.

2.2.3 Control sticks

To perform the simulated weapon aiming tasks two control sticks were used. Five subjects used a position stick which was simply a lever connected to two potentiometers which when suitably amplified gave X and Y co-ordinates of $\pm 5 \text{ V}$ full scale. These signals were connected to a 14-track recorder and to a tracking task computer described in sections 2.2.7 and 2.2.12 respectively.

Another five subjects used a force stick (often incorrectly called a pressure stick) which consisted of a lever, identical in shape to the position stick, which had been fitted with strain gauges to produce X and Y voltages proportional to the forces exerted on the lever. These signals were fed to the recorder and computer. The console was provided with arm rests which could be adjusted to restrain the subjects forearm from moving forwards, sideways and to some extent vertically. These arm rests were identical to those used on the control station for the Seawolf missile.

2.2.4 Keyboard

The keyboard used was a commercial hexo-decimal one with the letters blanked out. It resembled the type now being used in the aviation field. It was connected to circuits which produced contact closures to record the numbers on a digital tape recorder and an analogue voltage proportional to the digits (0-9 were represented by a voltage 0-0.9 V in 0.1V steps) which was connected to the 14-track FM recorder. The latter was necessary as a safeguard since experience had shown that the digital tape recorder available was not completely reliable.

2.2.5 LED display

This consisted of a 4-digit display each digit being 4mm high, made up of seven segments each consisting of two LEDs with a refresh rate of 1 kHz. The brightness of the display was set to be comfortable and without glare in the lighting conditions available. The display was mounted approximately 0.7 m in front of the subject and 20° below his horizontal line of sight.

2.2.6 TV camera

This was a standard video camera fitted with a wide angle (90°) lens used only to monitor the condition and activities of the subject.

2.2.7 Recorders and communications equipment

A commercial portable video recorder using $\frac{1}{2}$ in tape and connected to two monitors for experimenters and rig driver via a video distribution amplifier. A standard 14-track FM recorder conforming to IRIG intermediate and wide band group 1 specifications was used for the main acceleration recordings. A 2-way intercom was used to connect the subject to the simulator driver and the experimenters. The earpieces in the subject's headset could be disconnected by the experimenter to prevent communications between the rig driver and experimenters disturbing the subject whilst he was performing his various tasks. A digital tape recorder was provided by APU to record the signals from the keyboard for subsequent analysis on a computer at APU. Full details of the device are given in Ref 4.

2.2.8 Tracking task display

This display measured 10 x 8 cm and was a duplicate of the one incorporated in the computer. The target presented to the subject was a 5mm diameter circle and a 5mm cross was used as the weapon aiming indicator. Both the cross and circle were in green on a black background.

2.2.9 Ship motion tape recorder

This was a 4-track FM recorder used for the reproduction of ship motion. Heave, pitch and roll displacement and rotations were recorded on the first three tracks and a 5V spike pulse on the fourth. The spike was used to trigger the computer to present the weapon aiming task and to trigger the LED driver to present the numbers to the subject. Fifty spikes were used on a 21 min recording of ship motion. Each spike occurred 1 s before a particular type of heave motion namely: smooth or relatively little motion; top of a peak; bottom of a peak; zero crossing going upwards and zero crossing going downwards. There were ten spikes for each kind of motion which were randomly selected throughout the recording to produce spikes not less than 9 and not more than 54 s apart. Part of the ship motion and spike record is shown in Fig 5.

2.2.10 LED drive system

The drive system for the LED display consisted of an eight-hole paper tape reader (ASCII format) linked to circuits which when triggered from an internal clock or external signal (ie the spike would monitor above) would read four ASCII characters from paper tape and present them to the LED display. Each group of four was shown for 4 s after

being triggered and the display was then left blank until triggered again. The paper tape used was made up from 200 random numbers in groups of four and was made into a tape loop.

2.2.11 Analyser and monitor

The analyser used for on line monitoring was a 400 word device which could produce a Fourier analysis of any signal and compare it with a subsequent signal. It was used to give on line indications of spectra and to show up vibration artifacts of the simulator.

The monitor used was a standard two-channel CRO which was connected to appropriate recorder channels to confirm that sensible signals were being recorded for each part of the experiment.

2.2.12 Tracking task computer

The tracking task was controlled by a CED minicomputer with 32K store and twin 150K floppy discs. The computer presented a circle 5mm diameter which constituted the target and a cross (5 mm across) which was controlled by the subject on a 10 x 8cm screen. Details of the motion of the circle are given in section 3.1.

3 EXPERIMENTAL DESIGN - INTRODUCTION

Ten subjects were selected from staff at APU and their details are shown in Table 1. It was considered that as this was a preliminary experiment with many uncertainties regarding the rigs' availability and performance, it would be better to use subjects easily available rather than to have say Naval staff or the general public. In future work this matter would be reconsidered. The ten subjects consisted of eight males and two females in the age range of 22-60. Table 2 gives a list of tasks in chronological order for each subject. Fig 7 shows the experimental design schematically.

Table 1

Subject	Sex	Weight (kg)	Age (yrs)
1	m	82	54
2	f	67	45
3	m	75	40
4	m	75	48
5	m	70	30
6	m	99	51
7	m	68	60
8	f	67	24
9	m	74	45
10	m	72	23

Table 2
Experimental Procedure

1	<p>Before each $\frac{1}{2}$-day session</p> <p>(a) 0.6 mg Hyoscine given if necessary.</p> <p>(b) Cast made for bite bar.</p> <p>(c) Subject adjust seat for right distance and height.</p> <p>(d) Lap belt adjusted.</p> <p>(e) Arm rests adjusted.</p> <p>(f) Subject shown emergency stop button, fire extinguisher and vomit bags.</p> <p>(g) Headphones put on and adjusted.</p>
2	<p>Part I</p> <p>(a) 20 tracking runs - no motion.</p> <p>(b) 2-track tracing - no motion.</p> <p>(c) Subjective ratings (1).</p> <p>(d) 50 + 50 tracking runs - ship motion.</p> <p>(e) 2-track tracings - ship motion.</p> <p>(f) Subjective ratings (2).</p> <p>(g) 15 tracking runs - no motion.</p> <p>(h) 2-track tracings - no motion.</p> <p>(i) Subjective ratings (3).</p> <p>5-min break.</p>
3	<p>Part II</p> <p>(a) Position control stick subjects only; hand transmissibility under ship motion (3 min).</p> <p>(b) Head transmissibility under ship motion - 3 min back off and 3 min back on.</p> <p>(c) Subjective ratings (4).</p> <p>(d) Keyboard task - 21 min ship motion.</p> <p>(e) Subjective ratings (5).</p> <p>(f) Head transmissibility under sinusoidal motion - back off backrest for session 1 - back on backrest for session 2.</p> <p>(g) Subjective ratings (6).</p> <p>(h) Position control stick subjects only:</p> <p style="padding-left: 20px;">(i) Hand transmissibility under sinusoidal motion.</p> <p style="padding-left: 20px;">(ii) Hand transmissibility under ship motion - arm rests removed.</p>

3.1 Tracking task

In the pursuit tracking task subjects attempted to centre a cross in a randomly moving circle (target). Each trial lasted 7 s with an average of 25 s between trials. Half the subjects used a force control and half a spring centred free moving control. For both groups the control law governing the relationship between the position or force on

the control stick and the movement of the cross was 1:3:1 for position, velocity and acceleration of the cross. This control law was one accepted by many researchers as the optimum for accuracy¹.

The circle moved in a quasi-random motion around an area in the centre of the screen (50% of total area). The cross started each run at a random position outside the central area. The subjects task was to acquire the circle as quickly as possible and to remain as close to it as possible. Each run was preceded by a 1s presentation of the word 'ready' on the screen. The runs were triggered by the ship motion recorder (see section 2.2.9).

The computer recorded the distance (error) between the cross and the circle, together with the heave, pitch and roll accelerations at the floor of the cabin. Acquisition of the target was defined as keeping the cross within 5 mm of the centre of the circle continuously for 1 s. The performance measures taken were: time to acquire the target; average errors after acquisition together with the maximum accelerations in heave pitch and roll at frequencies below 1 Hz for 3 s before and 4 s after acquisition.

Each subject was trained in the task at the APU before the main experiment to such a degree that learning effects would be minimal. Each subject repeated the experiment twice on different days but at the same time of day. Before motion commenced the subjects would complete the tracking task with the same time intervals as those used with motion for the first 20 spikes of recording. This was followed by two consecutive sessions of the recorded motion driving the rig and another static tracking session for 15 spikes. The motion was derived from measurements on HMS Avenger (frigate) at 25 kn into a force 4 sea. The average heave rms was 0.026 g with much smaller figures for pitch and roll. See Appendix B for detailed analysis of the heave motion.

3.2 Head transmissibility measurements

Before the trials began a bite impression was made for each subject using dental moulding compound attached to an aluminium bar. The appropriate bar was attached to the transducer frame before a morning or afternoon session began.

Transmissibility was measured for both ship and sinusoidal motion. Ship motion was applied for approximately 3 min with the subject sitting forward, off the back rest, whilst fixating his eyes on a spot on the console and a further 3 min with his back resting on the back rest.

Nominally sinusoidal motion was applied for each axis in turn for frequencies of 0.1, 0.15, 0.2, 0.25, 0.3 and 0.4 Hz. For this purpose the rig was driven by an oscillator whose frequency was changed manually. Due to rig stress limitations the amplitude of the oscillator was restricted to give heave amplitudes of ± 1.1 m to ± 0.2 m, and to $\pm 5.5^\circ$ to $\pm 4^\circ$ for the pitch and roll axis for each of the above frequencies.

3.3 Hand transmissibility

Hand transmissibility was measured for those five subjects who used the position control stick. It was considered that there would be little or no relative motion induced in the hand when a force control stick was used as the stick itself cannot move more than

a minute amount. The miniature accelerometer block described in section 2.2.2 was taped to the right forefinger knuckle with the axis of measurements as near as possible to the vertical, fore and aft and lateral axes of the subject. Measurements were made under ship motion (3 min) and the same sinusoidal motions as described in section 3.2. In addition ship motion was also applied with the arm rests removed to see if the arm rests really did inhibit relative motion.

3.4 Keyboard task

As described in section 2.2.9, the spikes on the fourth channel of the ship motion tape recorder were used to drive both the tracking task and the LED display in turn. The subject was instructed to read out aloud the numbers as they appeared on the display and to type them on the keyboard after reading them. The reading out of the numbers was thought to be necessary to ensure that any error in typing was not caused by a visual error. The voice was recorded via the intercom onto the 14-track recorder.

3.5 Track tracing task

A copy of the track tracing task sheet is shown half scale in Fig 8. It was considered that even if all the other tasks showed no decrement in performance this task would. Each subject was instructed to stand facing the end wall of the cabin and to draw accurately on each sheet which was at shoulder height, following the lines. The subjects were not allowed to hold on with their non-writing hand. The subjects attempted this task six times during each session with the middle two attempts under ship motion. The subject was timed for each sheet and the sheets renewed after each pair of runs.

3.6 Subjective ratings

Each subject was instructed to complete a short questionnaire six times during each session. The criteria covered were: performance, wellbeing, dizziness, skin moisture, headache, stomach awareness, mouth moisture and vision. Each was represented on a 10cm line with extreme criteria at each end of the line. A copy is shown in Fig 9.

4 RESULTS

The simulator was only capable of being driven by displacement signal for the heave, pitch and roll and as described in Appendix B was limited in its reproducibility. Fig 5 shows part of the ship motion recording used to drive the simulator and Fig 10 its vertical acceleration response at the floor of the cabin. It can be seen that higher frequencies were present which might have affected the subject. For the case of sinusoidal motion Fig 11 shows the output acceleration and its spectra for the pure sine wave displacement input. Although the inputs were essentially at specific frequencies as the oscillator was manually changed there is some energy at the intermediate frequencies.

4.1 Rotational acceleration measurements

The rotational accelerometers used for measuring the rotation of the platform and the head were the Schaevitz Type AS. These types of transducers have been used by several researchers including Rance and Johnson⁵ and others in measurements of head acceleration and their specification was considered suitable for such measurements.

However subsequent evaluation of the experimental results and of the particular transducers used has revealed that because of an unsuspected defect (possibly due to mis-handling) they suffered from a very significant cross axis sensitivity which has produced signals greater than the signal being measured. For example the early testing of the simulator sine wave oscillations in pitch and roll at 0.1 Hz and $\pm 6^\circ$ produced measured accelerations of up to 2 rad/s^2 whereas calculations show that this motion should produce not more than 0.1 rad/s^2 .

The accelerometers were then tested by orientating them in the earth's gravitational field and the static outputs were found to change by 0.2 rad/s^2 for a change in orientation with respect to vertical of as little as 10° . It was subsequently found that these transducers had faulty bearings which produced erroneous signals.

In retrospect it is quite obvious that the inaccuracies in these accelerometers made them totally unsuitable for this work. This fact is very regrettable as all the rotational measurements made are unusable but it does highlight the need for better calibration facilities and testing procedures with more time being allowed for pre and post-experimental checks.

4.1.1 Head transmissibility for sinusoidal input

With reference to Fig 7 it can be seen that for ten subjects, three types of input, back on or back off and six-degrees-of-freedom of the head there is a possibility of 360 transmissibility curves. Eliminating the measurements of rotary motions of the rig and head this figure is reduced to 60. Fig 12a shows typical input and output relationships for one subject in the back on the back rest condition and Fig 12b the equivalent spectra. Transmissibility curves for heave, sway and shunt are shown in Figs 14, 15 and 18 for all subjects (intermediate frequencies deleted).

At first sight these graphs seem to indicate rather high transmissibilities at certain frequencies. With reference to the input spectra (as in Fig 12b) it can be seen that the main energy in the spectra is at 0.1, 0.15, 0.2, 0.25, 0.3 and 0.4 Hz with some energy in between as the input was manually swept from frequency to frequency. Careful scrutiny shows that, in general, the high transmissibilities do not occur at the specified frequencies except at and around the 0.1 Hz for *some* subjects.

Considering the intermediate frequencies above 0.1 Hz the most likely explanation for the apparent high values of transmissibility was that the input and output energy were relatively low, such that their division could lead to erroneous values being produced.

At and around the 0.1 Hz region some subjects produced what would appear to be very large ratios. For these measurements to be believed would mean that the head was moving around $\pm 1 \text{ m}$ relative to the body. Obviously this cannot be the case and after prolonged investigation it was discovered that the apparent high signal at the head was caused by head tilt. It was found that angular acceleration in itself was insufficient to cause the effect but the angular mean position of the bite bar was, for some subjects well below the horizontal. The head rotation was of the order of $\pm 6^\circ$ about the mean position, which if it had been vertical would have produced an error of not more than $\pm 8\%$ but as the *mean* position dropped, the apparent signal due to rotation within the earth's gravitational

field becomes significantly larger (see Appendix C). Other workers in the field using the bite bar technique have not detected this problem as their input accelerations and frequencies have been much higher but at these low levels the effect is sufficient to double the signal level for those people who seem to be more susceptible to head tilt. Video recordings had been taken for some of the subjects and these confirmed that the head was tilting in phase with the input motion. There was no correlation between head rocking and the subjective measures for motion sickness in any of the axes measured although a connection between the two cannot be ruled out.

In order to overcome the first problem (low energy at intermediate frequencies) the transmissibilities at each specific frequency were computed and Fig 16 shows the average and range of values obtained for each frequency and axis of measurement. Although the scatter was large the mean values for heave/heave indicate a small attenuation of the motion with slightly less attenuation in the back off situation. For the lateral measurements, discounting the 0.1 Hz value which again is probably due to head rocking, the transmissibility reduces as the frequency increases showing little cross coupling; however in the case of the fore/aft measurement nearly half the vertical input acceleration manifested itself in forward motion of the head. It is not known whether cross axis motion of the rig itself could have contributed to this motion.

4.1.2 Hand transmissibility for sinusoidal input

Figs 17 and 18 show the apparent transmissibilities of heave vibration to the hand for the same frequencies as in Fig 12a. The heave to heave transmissibilities were in general equal to one at the specific frequencies but some subjects had values as high as 1.34 and as low as 0.60. The sway/heave ratios showed some high values up to 7 which can be attributed to either insufficient energy in the input waveform or more probably rotation of the hand as explained in Appendix C. (See also Fig 4.) Similarly the high ratios for shunt/heave might be explained in this manner.

Fig 19 shows the mean and range of transmissibilities taken at the specific frequencies of induced motion. The values are not as high as in the previous two Figures but still exhibit values which are not explainable by biomechanical motions. As these values were obtained at maximum input energies, hand rotational errors might have produced such an effect.

4.2 Keyboard operation under ship motion

The subjects had been asked to read out aloud the numbers as they appeared on the console and to type them in as quickly as they could.

The subjects were first tested without motion for two runs and subsequently for one run on each of their two sessions under ship motion. The errors in typing the correct number were rare and accountable to slight deficiencies in the electronics driving the LED display. The mean time to type out the numbers is shown in Table 3 for each of the four runs. There was no significant difference ($P \leq 0.5$ Wilcoxon, 2 tail) between the static and motion sessions. Half the subjects were faster under motion.

Table 3
Mean typing times in seconds for 20 sets of 4-digit numbers

Subject	1	2	3	4	5	6	7	8	9	10
<u>Static</u>										
Mean run 1	0.97	1.02	1.31	0.89	0.64	1.12	1.20	0.97	1.65	1.31
Mean run 2	0.89	-	1.42	0.83	0.57	1.02	1.09	0.78	1.57	-
Mean (1 + 2)	0.93	-	1.37	0.86	0.60	1.07	1.15	0.88	1.61	-
Standard deviation (1 + 2)	0.19	-	0.36	0.11	0.07	0.28	0.18	0.22	0.30	-
<u>Motion</u>										
Mean run 3	0.99	0.91	1.40	0.96	0.71	1.05	1.24	1.28	1.49	1.04
Mean run 4	1.08	0.85	1.22	0.92	0.68	1.31	0.98	1.14	1.40	1.39
Mean (3 + 4)	1.04	0.88	1.31	0.94	0.69	1.18	1.11	1.21	1.45	1.21
Standard deviation (3 + 4)	0.22	0.10	0.34	0.19	0.15	0.40	0.29	0.25	0.31	0.38

4.3 Tracking task

The tracking tasks came solely under the auspices of APU and the results are quoted here for completeness.

"Two measures were taken on each trial: (i) time to acquire the target, (ii) mean modulus error after acquisition. 'Acquisition' was defined as putting the centre of the cross inside a circle radius 5 mm from the centre of the target circle and keeping it there for 1 s. The group mean data are shown below. The control data is the mean of the 20 pre-motion and the 15 post motion runs with the cabin stationary.

Tracking data

		Control stick	
		Pressure	Free moving
Acquisition time (s)	Control	2.8	3.0
	Motion	3.1	3.2
Mean modulus Error	Control	22	31
	Motion	31	37

Every subject shows a decrement going from control to motion in both acquisition time and error. There is no doubt that this degree of ship motion causes a drop in tracking performance even when there is no evidence of sea-sickness and when the subject is both strapped to the chair and has his fore-arms restrained."

4.4 Track tracing task

Again this experiment was conducted by APU and the results are now quoted:

"Two indices of tracing performance were taken - the time to complete the set of six outlines and the mean of the two largest errors. A comparison of the control tracings taken before and after motion with those obtained while the cabin was moving show (i) a large and reliable increase in error for every subject (mean error stationary = 2.7 mm,

mean error under motion = 8.6 mm); (ii) no reliable change in the speed at which the tracing was performed (average speed stationary = 46.8 s, average speed under motion = 48.5 s).

There are some clear qualitative differences between the tracing obtained under the two conditions. We are attempting to quantify these."

4.5 Questionnaire

These results were obtained from APU and are now quoted:

"None of the subjects actually vomited. However there was a small but reliable drop in the feeling of well-being. Comparing the estimate made immediately prior to motion with that made at the end of the first motion session gives a drop of 9% in the scale going from 'Fine' to 'Awful, about to vomit'. Pooling across days and subjects this is reliable, $p < 0.05$, Wilcoxon 2-tail. None of the individual indices (dizziness, sweating, headache, stomach awareness, salivation) showed a reliable change when pooled across subjects and days. At the end of the second motion session the position was very similar. Compared to the pre-motion ratings, 'well-being' pooled across subjects and days showed a reliable 7% decline ($p < 0.05$, Wilcoxon 2-tail). But none of the other individual indices showed a reliable change."

5 DISCUSSION AND CONCLUSIONS

5.1 Simulator response

The response of the simulator to both ship and sinusoidal motion was restricted and extra vibrations were induced through its structure by the loads imposed on the main frame. It is not known whether these vibrations had any effect on the subject's ability to perform his tasks but the roll and pitch motions induced by the heave motion were considered to have affected the horizontal measurements at the head. For sinusoidal inputs the resulting accelerations at the floor of the cabin had higher frequency components of magnitudes equal to the main inducing accelerations.

It was concluded therefore that although the simulator could produce the basic wave-forms required, structural resonances were far greater than desired and could be responsible for errors in transmissibility to the man, in addition they could have affected the man's performance. This is an area for further research to explore the range from 0.4-1 Hz *per se*. Improvements to this simulator to overcome these artifacts would be difficult and expensive and might impose other undesirable restrictions such as stroke limitations and reduced payloads. It is the author's opinion that a new facility is required geared particularly to human factor requirements.

5.2 Rotary acceleration measurements

The rotational accelerometers used in this experiment were found to have given erroneous readings because they could not withstand the linear accelerations imposed during handling and use. As other transducers available were many times heavier than those used it was considered that, for future work, greater control in the use of these accelerometers and more careful calibration and setting up would be necessary.

5.3 Head transmissibility

Essentially the head heave acceleration had a 1:1 relationship with the heave input. However head movement (particularly forward tilt) led to apparent high transmissibilities (due to errors it caused in accelerometer readings) for some subjects in the back off position. It might be that in the back *on* position some subjects held their head more firmly, restricting this motion.

The reason for this tilt is not known but boredom cannot be ruled out as the subjects had been asked to concentrate on a cross on the console for periods of over 3 min. In future transmissibility work consideration should be given to reducing this time and providing the subject with a concentration task involving small eye movements such that the subject's interest is retained without inducing head movements. If measurements of linear and rotational displacements were to be made it would be possible to cross check the acceleration results to avoid any 'g'/head angle effects or at least to compensate for them.

As the head tilting and rocking motion at frequencies known to be associated with motion sickness was more predominant with some subjects than others there could be some correlation with motion sickness which was not detectable in this experiment.

In the case of lateral motion of the head there appears to be little effect due to heave motion but for fore/aft motion roughly half the heave is translated into forward motion for all frequencies. It could be that this effect is a result of the head tilt/rocking motion. Again displacement measures would resolve this question.

5.4 Hand transmissibility

The vertical transmissibility of the hand showed an approximately 1:1 relationship at the frequencies measured. Theoretically one would have expected an exact correlation of 1.0 between the two as the hand did not leave the control stick and the variation observed can only be attributed to measurement artefacts probably caused by hand rotation. The lateral and fore/aft measures produced large transmissibilities which, in the author's opinion, can only be caused by hand rotations and in future work more consideration should be given to displacement measurement to find out how much the hand moves involuntarily under this sort of motion.

5.5 Keyboard task

The results showed no significant effect of ship motion on the subjects' ability to type numbers with half the subjects being faster under motion. There was no effect on accuracy of typing. As the motion had little significant effect on this task it could be retained for use as a secondary task in future experiments.

5.6 Tracking task

All subjects showed a small but reliable decrement in performance under ship motion for both force and free moving controls although only one ship and one (mild) sea-state were considered. It is considered that such tasks should be assessed under a variety of ship motions and sea states firstly to confirm these results and secondly to ascertain

whether some tracking tasks are more affected by motion than others. There could be scope for optimising a design around tasks which are relatively unaffected by motion.

5.7 Track tracing task

This task involving continuous whole arm movement was seriously affected by this relatively mild ship motion. The average error increased by a factor of 3 and many of the individual records were so bad that without the visible target tracing it would have been difficult to guess what the subjects intended drawing had been.

5.8 Recommendations

The experiment has confirmed that there is a clear need for investigation of human performance under a wide range of low frequency motions below 1 Hz. Such a need cannot be met using existing motion simulators in the UK as it is not possible to differentiate performance degradation between intended motions and those induced by impurities in rig response. A new simulator is required which can generate controlled motions with much better fidelity. There is also a need to improve the instrumentation to measure the bio-dynamic performance of subjects to create a better understanding of what factors cause involuntary movements of people under such motions.

Acknowledgments

The author would like to thank all those who took part in the experiment, particularly Harry Hughes and Wynn Lewis at the Warren Springs Laboratory whose persistence made the experiment possible. I would also like to thank the staff at APU who acted as volunteers and those who helped to run the experiments and to Hugh Stockbridge (SPN) who co-ordinated the funding of the experiment. Finally I would like to thank Geoff Allen and Dave Howarth of the RAE for their help in the analysis and execution of the experiment.

I would also like to thank Mike Griffin (ISVR) for the loan of the control sticks and John Wharf (RAE) for the loan of the LED display system.

Appendix ADESCRIPTION OF THE WARREN SPRINGS SIMULATOR AND
THE MODIFICATIONS REQUIRED FOR THIS EXPERIMENTA.1 Rig description

The ship motion simulator at Warren Springs was developed for use in assessing transportation problems of semi-solid cargoes, and as such was not man-rated. The rig had to be strengthened to accommodate the higher cantilever loads induced when the large cabin was placed on it.

The simulator was designed to have a stroke of ± 1.85 m and pitch and roll of $\pm 8^\circ$ with a payload of 1 ton operating in the range of 0.1-0.3 Hz dependent on stroke. Its cantilevered platform was driven by a chain coupled to a hydraulic vane motor via a reduction gearbox. Additional steel cables were included in case of chain breakage. The pitch and roll were driven by two hydraulic jacks mounted between the cantilever and the platform. The jacks and motor were controlled by built-in oscillators whose phase relationship could be set by the operator. Displacement feedback was used for each axis.

A.2 Cabin description

The cabin was constructed in corrugated aluminium on steel frames having a semi-circular top in cross section. Its overall dimensions were 2.34m x 1.83m x 1.96m high. It was provided with a sliding door and an outside catwalk, with safety rails. The cabin contained hand rails along its two longer sides, ventilators, extractor fan and usual electrical facilities together with a safety stop button and fire extinguisher. To accommodate the cabin and its movement the platform had to be repositioned on a longer cantilever structure which in turn created higher loads on the main running wheels. (During the experiment the rubber tyre on one of the wheels sheared from the wheel and had to be replaced.)

A.3 Additional safety requirements for man-rating

To man-rate the rig it was necessary to conform to BSI specification DD23 extended to cover the range down to 0.1 Hz. To do this the following changes were incorporated:

- (a) Emergency stop switches were located in the cabin, rig driving console and the experimenters monitoring room.
- (b) Limit switches for the vertical travel were installed. In the event of operation of these switches the rig was to halt in a controlled manner with accelerations of less than 1 g.
- (c) Fail-safe check valves in the servo-controlled valves were incorporated to maintain pressure and position in the event of electrical or hydraulic failure.
- (d) In the event of a hydraulic failure a 4-gallon hydropneumatic accumulator coupled to the downward drive side of the hydraulic heave motor was used as an emergency power supply to bring the platform down to the demounting position. This would function through a pilot operated five-port change-over valve.

(e) In the event of electrical supply failure the servo valves would return to zero and the platform would stop maintaining its position by the check valves. To bring it down to the demounting position an emergency mains supply, derived from a battery operated inverter would be applied manually to the solenoid valve which would operate the accumulator controlled descent. As a 'back-up' system the emergency supply could be switched to operate the manually controlled generator used for normal descents. The hydraulics layout is shown in Fig A1.

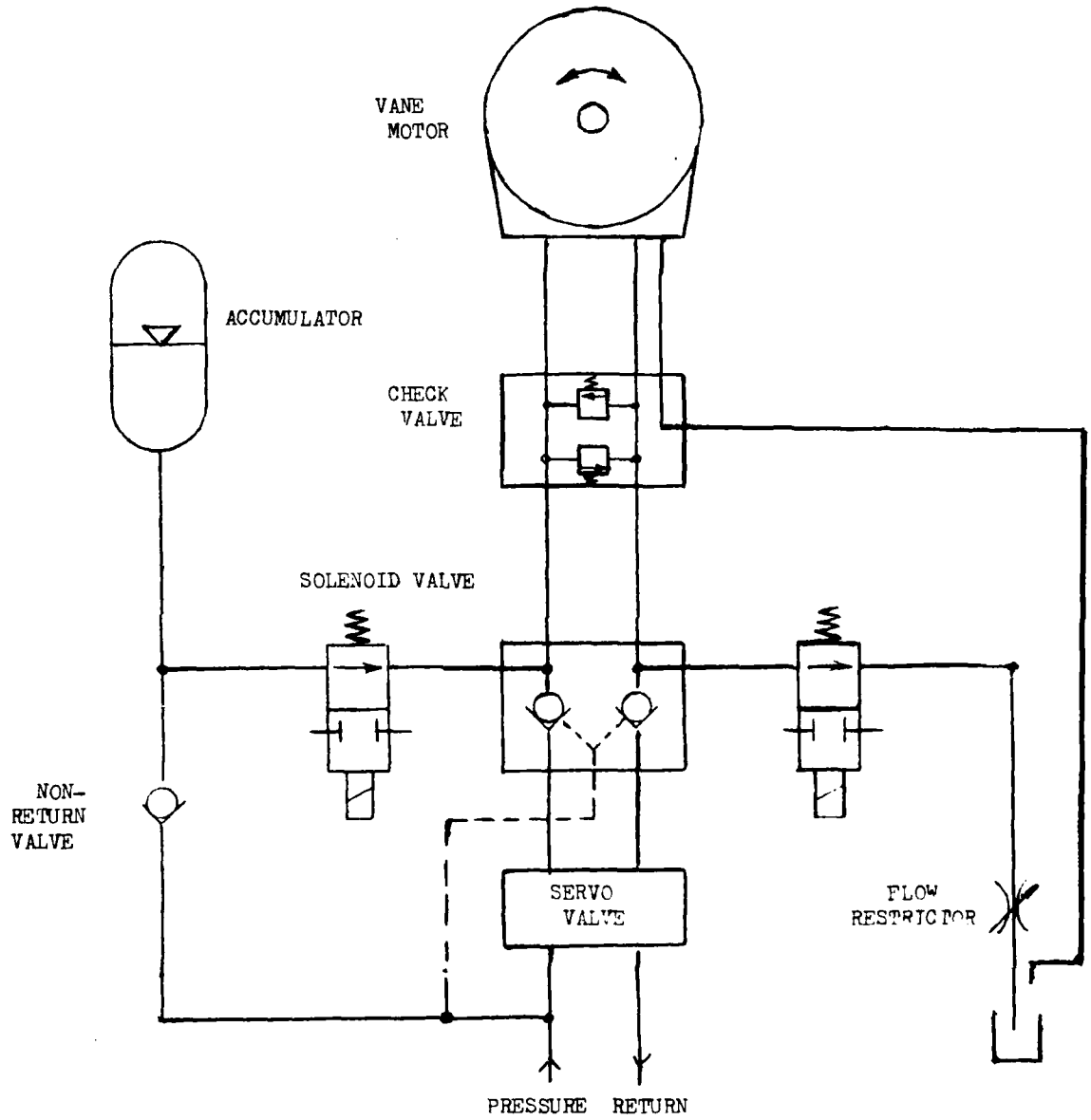

Fig A1 Hydraulic system with emergency failure check valves

Appendix B

ANALYSIS OF HEAVE MOTION

The displacement driving signals for the simulator are shown in Fig 6 and the heave response for ship and sinusoidal motion in Figs 10 and 11. It can be seen that the measured acceleration of the platform has a wider bandwidth than the input signal. The figures were derived from 1000 s of data which covers more than three-quarters of the total ship motion record used in the experiment. Computing limitation requires that these response curves limit at 2 Hz. Higher response can only be achieved by taking shorter periods.

The overall rms 'g' for this period was 0.024; however the tracking and keyboard tasks took place over periods of 7 s and were designed to cover differing ship motion conditions. As stated in section 2.2.9 the spikes for triggering the tasks were placed 1 s before the various types of heave motion *viz*: smooth motion; top of a peak; bottom of a peak; zero crossing going upwards and zero crossing going downwards. There were ten spikes for each type of motion placed such that there was a period of not less than 9 s and not more than 54 s between spikes. The actual accelerations immediately following each spike varied from 0.059-0.001 g rms taking 5 s of data starting 1 s after each spike.

Table B1 shows the wide variation in acceleration relating to each spike and to the period following each spike. Columns 4 and 5 give data on the mean of the modulus of the accelerations for the acquisition time (approximately 3 s) and holding time (approximately 45 s) and it can be seen that the acceleration level can change considerably between these periods. This is to be expected when the task time is of the same order as the basic period of oscillation. The letters in column 4 represent the types of heave motion derived from the original displacement curves *viz*:

- A = smooth motion
- B = top of large peak
- C = bottom of larger peak
- D = zero crossing going upwards
- E = zero crossing going downwards.

It was not possible to obtain precise correlations between tracking and the type of motion due to the variability of the accelerations. In future work consideration should be given to a better definition of the input acceleration signal to try to relate the motion to performance decrement. It might be that a pseudo-random waveform with more definable areas would be more suitable until a greater understanding is achieved of the relationship of the task to the motion. It might then be possible to relate the task to ship motion and to determine the worst case condition.

Table B1

RMS AND MEAN MODULUS HEAVE ACCELERATIONS FOR PERIODS
FOLLOWING THE TRIGGER SPIKES

(The letters in column 4 are described in the text)

Spike No.	Rms 'g' 5 s	Rms 'g' 10 s	Mean modulus 'g' 3 s	Mean modulus 'g' 4 s
1	0.019	0.0183	A 0.0081	0.0169
2	0.037	0.0360	C 0.0277	0.0258
3	0.033	0.0301	B 0.0268	0.0144
4	0.029	0.0275	D 0.0158	0.0182
5	0.014	0.0241	A 0.0126	0.0159
6	0.031	0.0343	B 0.0231	0.0254
7	0.040	0.0369	C 0.0304	0.0320
8	0.038	0.0329	E 0.0302	0.0293
9	0.037	0.0375	D 0.0200	0.0407
10	0.018	0.0275	B 0.0237	0.0236
11	0.031	0.0333	E 0.0300	0.0239
12	0.018	0.0288	A 0.0126	0.0195
13	0.036	0.0329	D 0.0230	0.0235
14	0.038	0.0303	C 0.0325	0.0183
15	0.038	0.0328	B 0.0373	0.0233
16	0.055	0.0478	E 0.0426	0.0351
17	0.014	0.0248	A 0.0098	0.0175
18	0.040	0.0322	C 0.0363	0.0209
19	0.028	0.0334	A 0.0147	0.0243
20	0.022	0.0254	A 0.0148	0.0219
21	0.038	0.0283	E 0.0286	0.0177
22	0.033	0.0318	D 0.0245	0.0224
23	0.036	0.0287	B 0.0281	0.0182
24	0.029	0.0273	B 0.0322	0.0165
25	0.045	0.0281	D 0.0353	0.0285
26	0.040	0.0307	E 0.0375	0.0154
27	0.045	0.0443	C 0.0399	0.0309
28	0.049	0.0407	B 0.0398	0.0253
29	0.032	0.0252	C 0.0297	0.0180
30	0.037	0.0308	D 0.0293	0.0185
31	0.001	0.0117	A 0.0046	0.0101
32	0.032	0.0349	E 0.0269	0.0318
33	0.029	0.0286	C 0.0217	0.0136
34	0.031	0.0243	D 0.0231	0.0119
35	0.029	0.0292	D 0.0138	0.0241
36	0.014	0.0115	A 0.0052	0.0109
37	0.027	0.0232	B 0.0172	0.0104
38	0.028	0.0249	E 0.0150	0.0208
39	0.032	0.0310	C 0.0276	0.0223
40	0.034	0.0349	E 0.0263	0.0275
41	0.037	0.0388	B 0.0236	0.0261
42	0.049	0.0413	C 0.0420	0.0204
43	0.059	0.0490	E 0.0449	0.0460
44	0.037	0.0286	D 0.0226	0.0228
45	0.043	0.0396	B 0.0392	0.0308
46	0.027	0.0308	A 0.0169	0.0188
47	0.024	0.0264	D 0.0144	0.0240
48	0.021	0.0196	B 0.0158	0.0112
49	0.037	0.0327	A 0.0321	0.0191
50	0.030	0.0244	C 0.0190	0.0190
Mean	0.032	0.0306	0.0250	0.0221

Appendix C

ERRORS IN THE USE OF LINEAR ACCELEROMETERS WHEN ROTATED

Rotary motion of linear accelerometers induces two types of error signal. Firstly there is a centripetal force acting normal to the direction of movement which is equal to $r\dot{\theta}^2$ where r is the radius of the rotation and $\dot{\theta}$ the angular velocity plus a tangential force equal to $r\ddot{\theta}$ (see Fig C1). However at the frequencies of interest (0.1-0.2 Hz) these forces are extremely small compared with the input signal. Secondly there is a signal due to the tilt of the transducer within the earth's gravitational field (see Fig C2). For transducer A, with no tilt, the force producing a signal is equal to the induced vertical acceleration plus 1 g due to gravity (which is balanced out electrically). When the transducer is tilted the gravitational effect is reduced to 'g' cos θ . For most purposes this effect is small (0.004 g for 5° tilt) compared to the driving signal and can be neglected. Thus if the accelerometer rotated $\pm 5^\circ$ in sympathy with a driving signal of ± 0.05 g (typical low frequency level) the error induced would be $\pm 8\%$ which although not insignificant could be tolerated. However, if a constant tilt was induced by the subject of say 20° and a sympathetic rotation of $\pm 5^\circ$ at and about that tilt then the measured signal would vary from 'g' cos 15° to 'g' cos 25° (0.029-0.094 g) representing an error of ± 0.032 g which is 64% of a driving signal of ± 0.05 g. Thus it can be seen that for those subjects whose neutral head position was tilted forward and whose head rocked in sympathy with the heave motion large errors would be induced which would create high transmissibilities. (These calculations have assumed that the accelerometer itself had zero cross-axis sensitivity which was not the case. However, the transducers used had a 2% per 'g' cross-axis sensitivity which could be neglected.)

In the case of a transducer intending to measure the horizontal acceleration (B in Fig C2) the situation is similar except that the gravitational effect induces 'g' sin θ on to the measured acceleration. For the fore/aft measurement of the head, if high tilt and rotation angles were present (say 20° and $\pm 5^\circ$ respectively) the apparent signal would change from 0.26-0.42 g, ie ± 0.08 g resulting in a transmissibility of 1.6 for a ± 0.05 g driving signal. For lateral induced motion it has been assumed that there is no constant tilt either to the left or right and that sympathetic rotation could only occur about a mean vertical line. However if the rotation was of the order of $\pm 5^\circ$ the signal induced would be ± 0.09 g leading to a transmissibility of 1.8.

In conclusion it has been shown that linear accelerometers can give very erroneous results if allowed to tilt and rock in sympathy with the input motion. The only way to overcome this problem is either to measure rotation of the hand or head and subtract the error from the signal or to compute transmissibility by measuring input and output displacements. Both require accurate relative positional measurement which is difficult to achieve without imposing severe restraints to the hand or head.

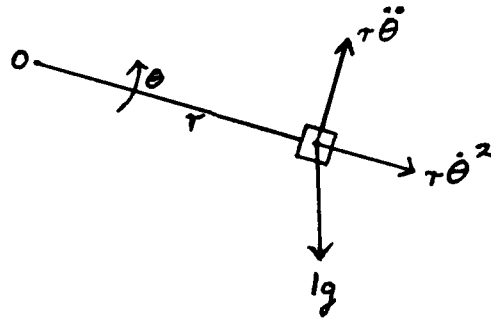
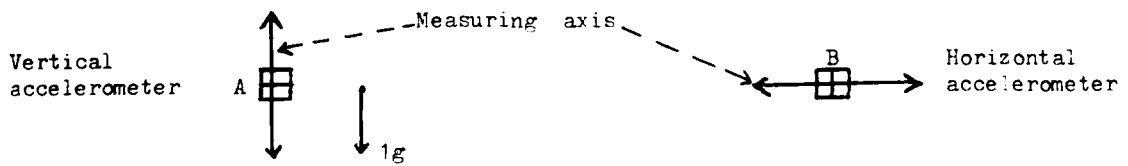
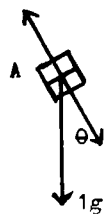

Fig C1 Accelerations acting on a transducer rotating in the earth's gravitational field about O in a vertical plane



NO TILT



θ° TILT

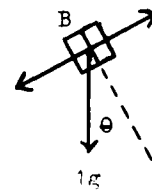

Fig C2 Gravitational field inducing accelerations on vertically and horizontally measuring accelerometers

REFERENCES

- | <u>No.</u> | <u>Author</u> | <u>Title, etc</u> |
|------------|--|---|
| 1 | F. McLeod
<i>et al</i> | The influence of ship motion on manual control skills.
SMWP3-80 MRC, March 1980 |
| 2 | J.T. Reason
J.J. Brand | Motion sickness.
Academic Press (1975) |
| 3 | T.H. Hughes | Effect of environment on processing and handling materials at sea.
Phil Trans R Soc, London A290 (1978) |
| 4 | R.C. Bloomfield | Event timing and recording in digital format for on-line
experiments.
Ergonomics, Vol 21 (1978) |
| 5 | M.E. Johnson
S.C. Bateman
B.H. Rance | Vibration transmission to the head of subjects seated in
experimental reclined seat.
RAE Technical Memorandum FS 182 (1978) |

TM FS 365

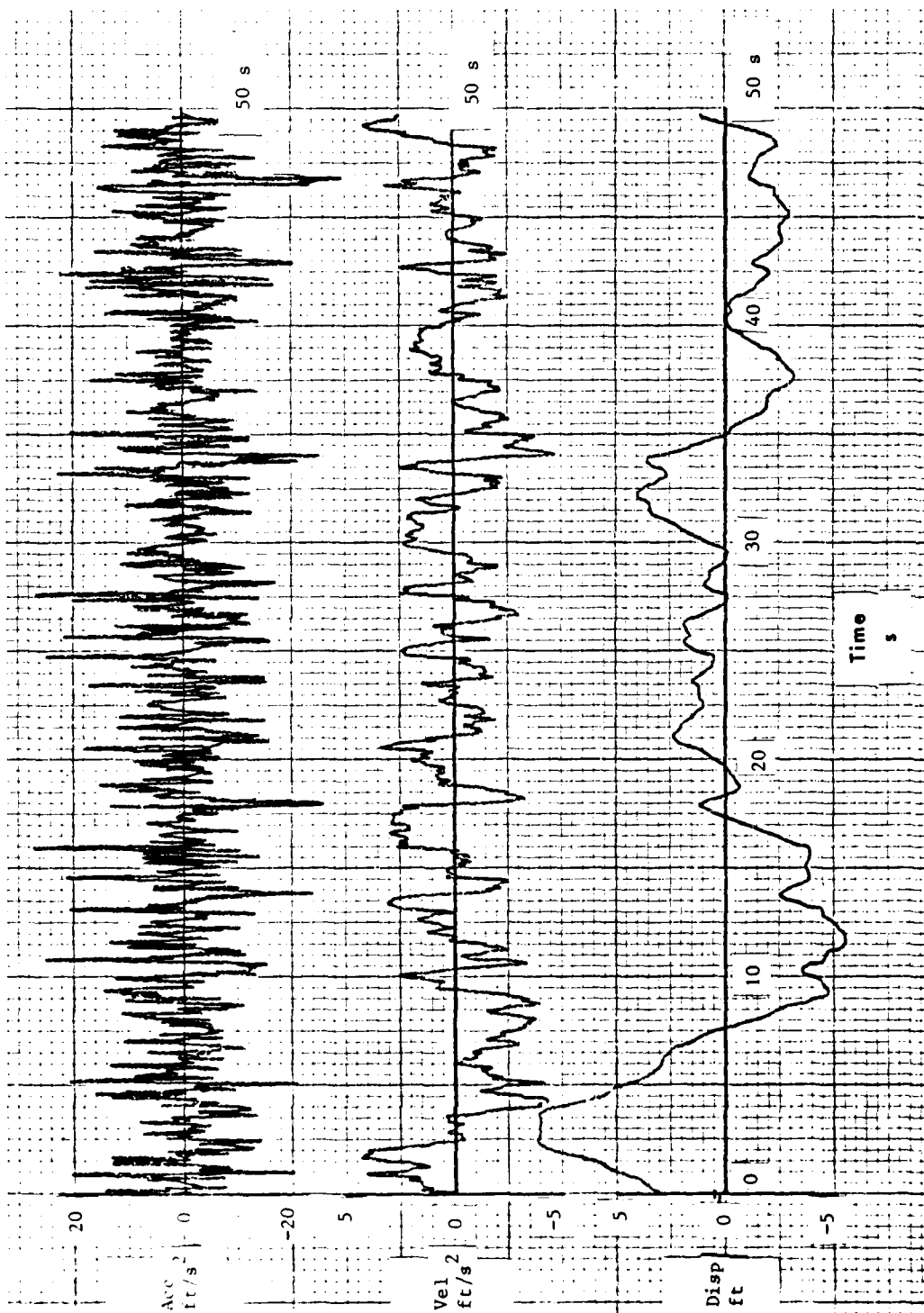

Fig 1 Vertical motion of Canberra

Fig 1

Fig 2

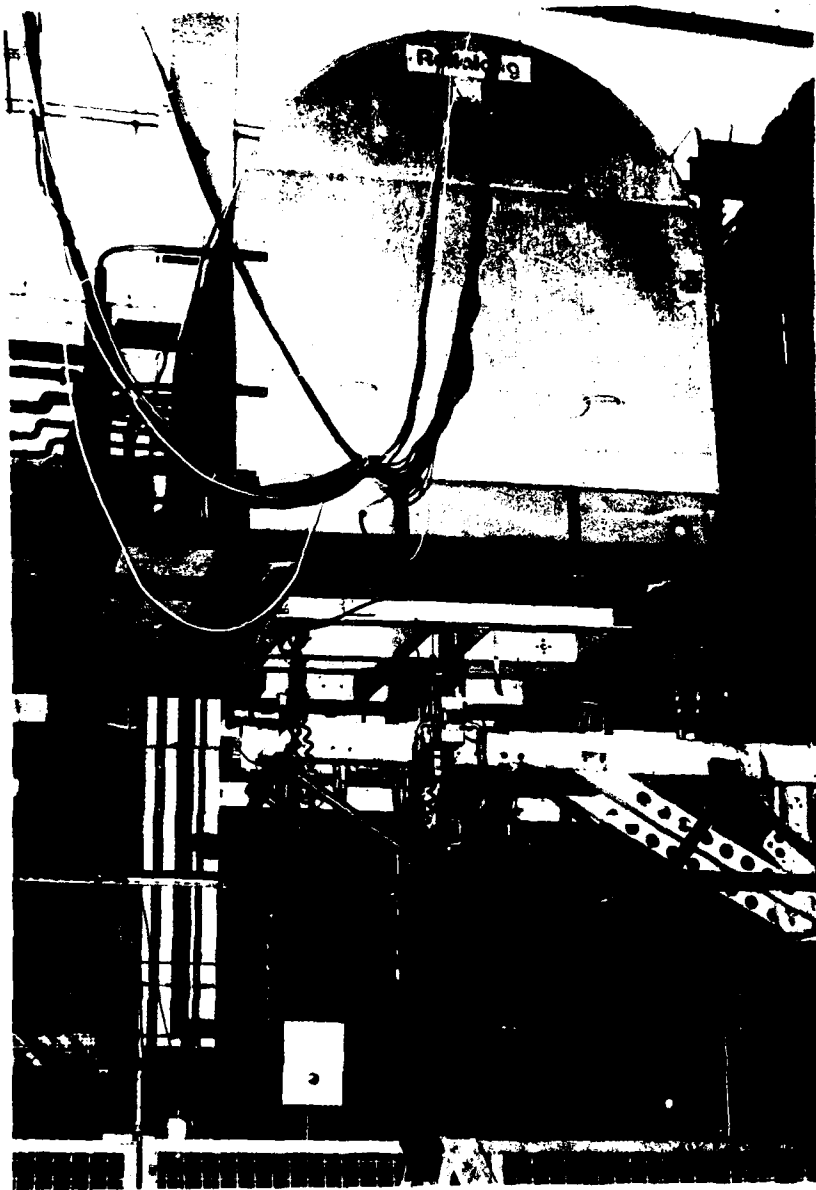
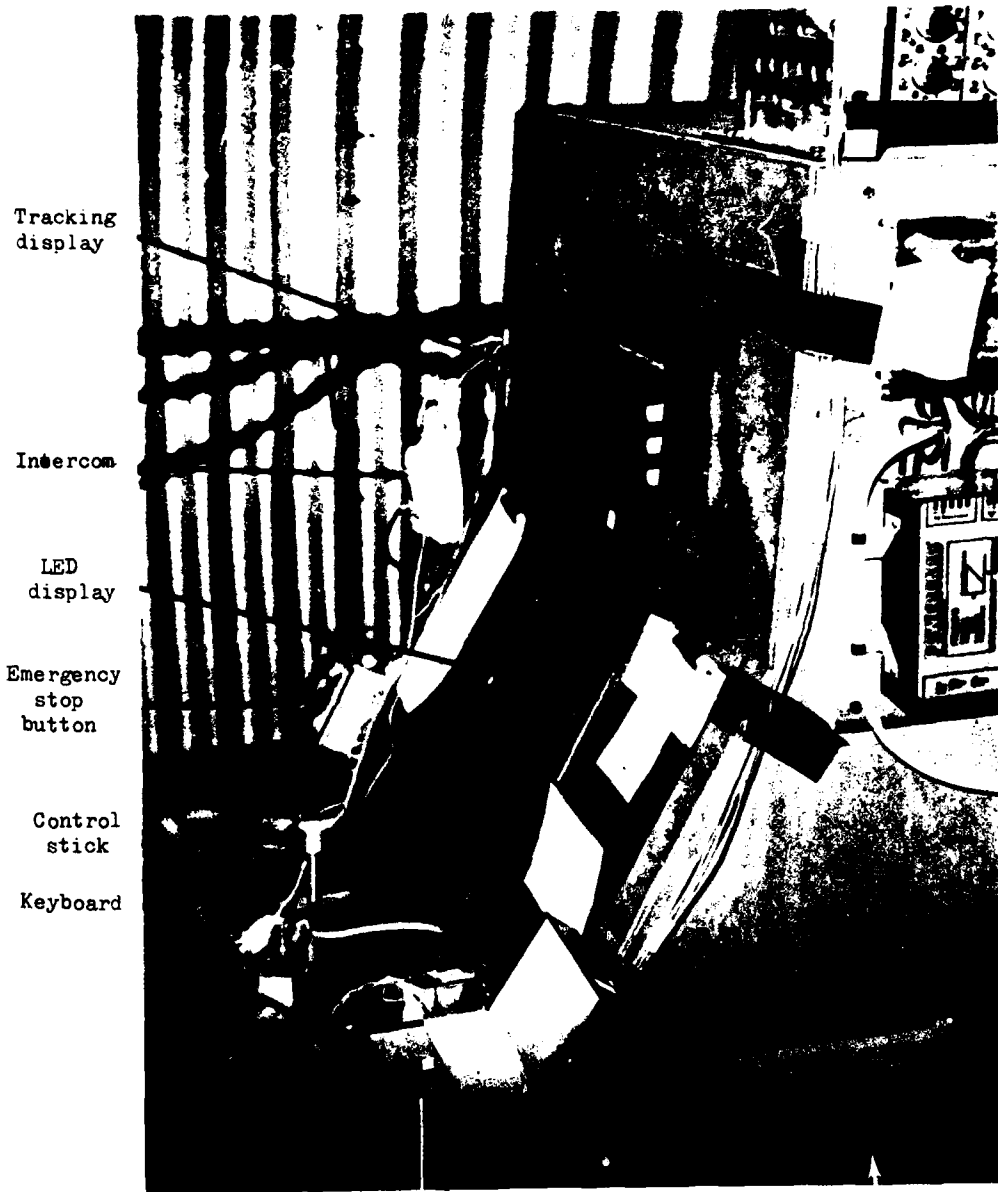

Fig 2 Cabin mounted on platform connected to cantilevered heave motion generator via roll and pitch jacks



Tracking display

Intercom

LED display

Emergency stop button

Control stick

Keyboard

Hand accelerometers

Bite bar

TM FS 365 C16543

Fig 3 Console layout

Fig 4

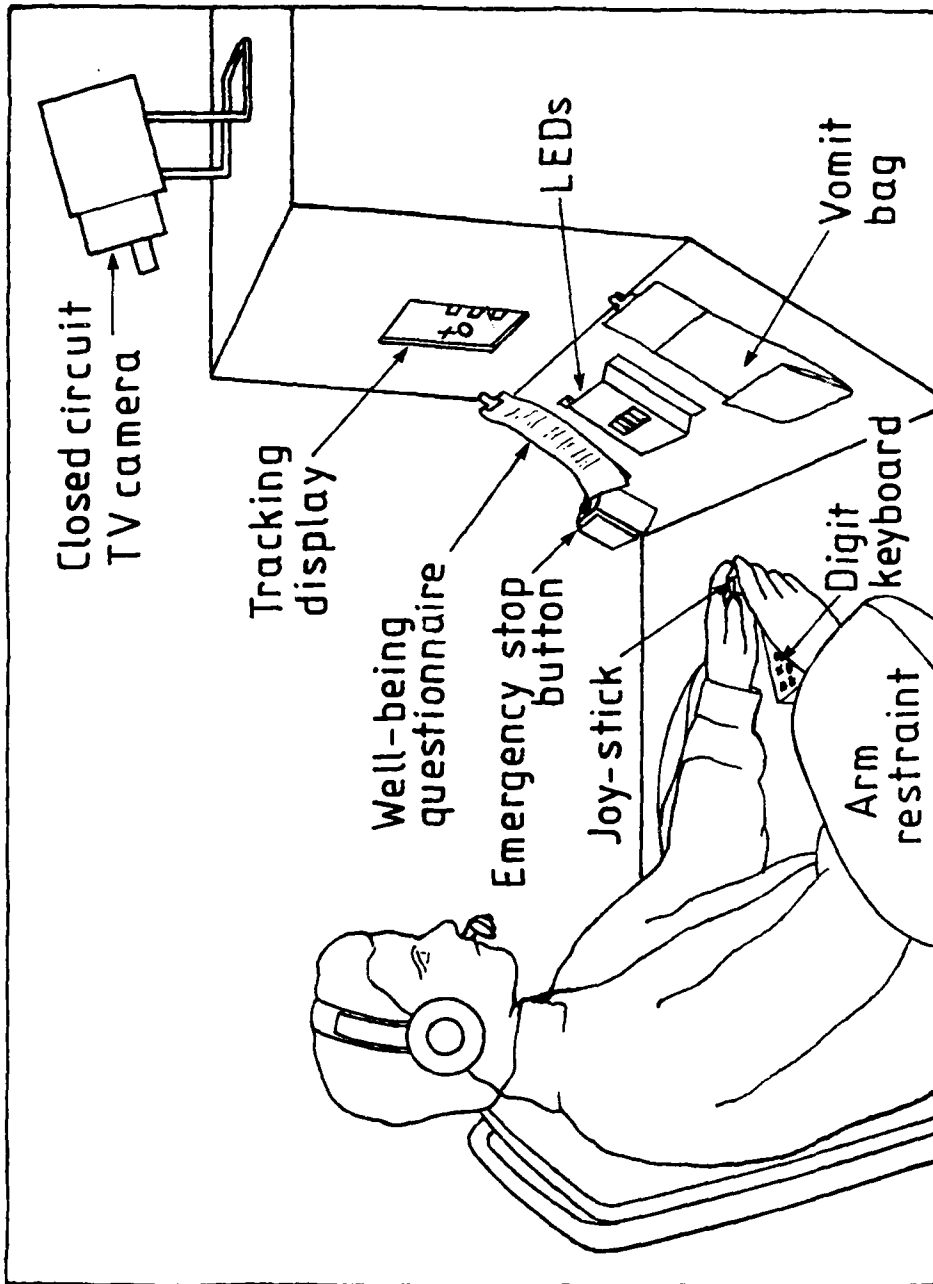
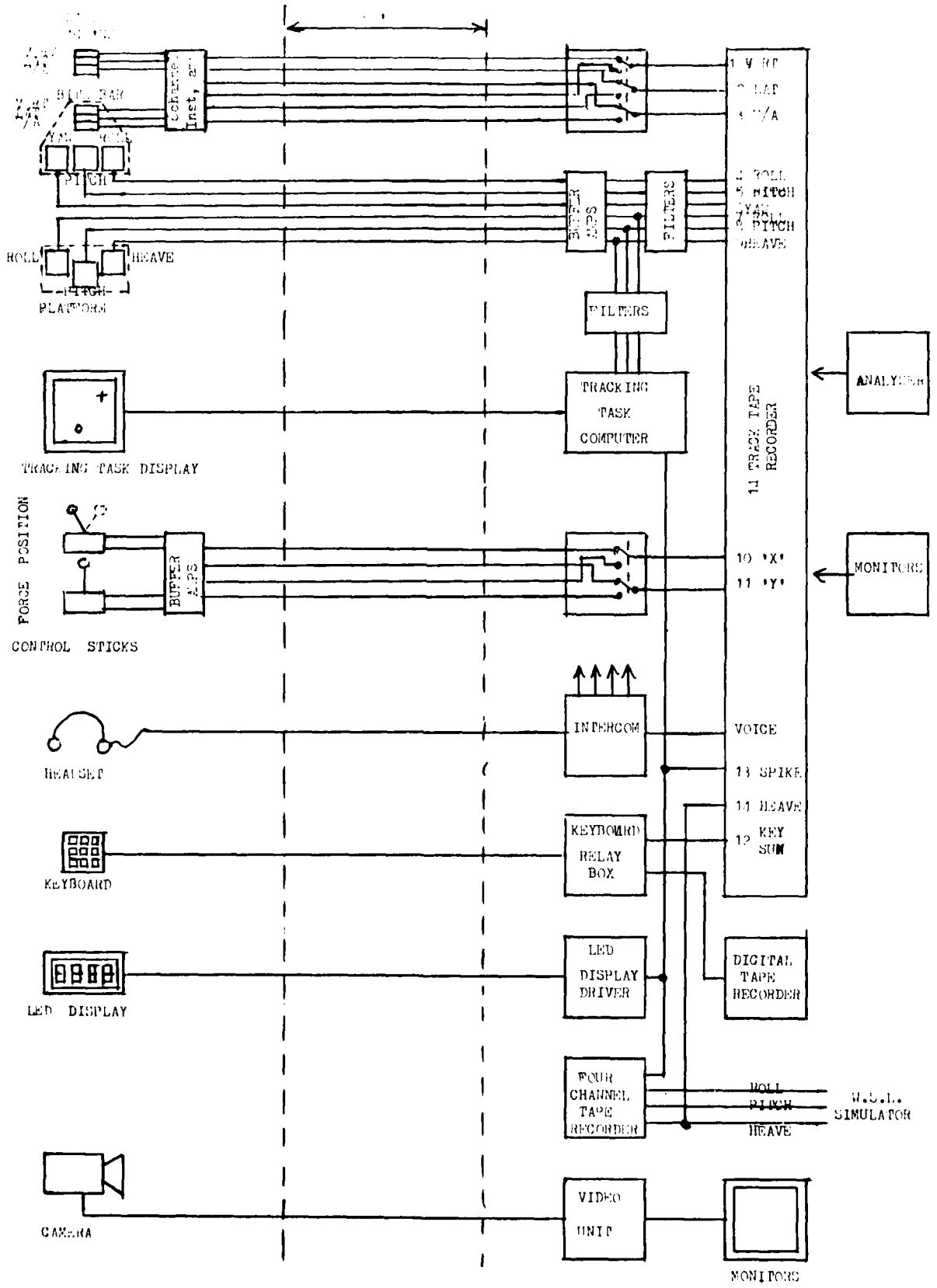

Fig 4 Outline of subject and console

Fig 5



TM FS 365

Fig 5 Equipment schematic layout

Fig 6

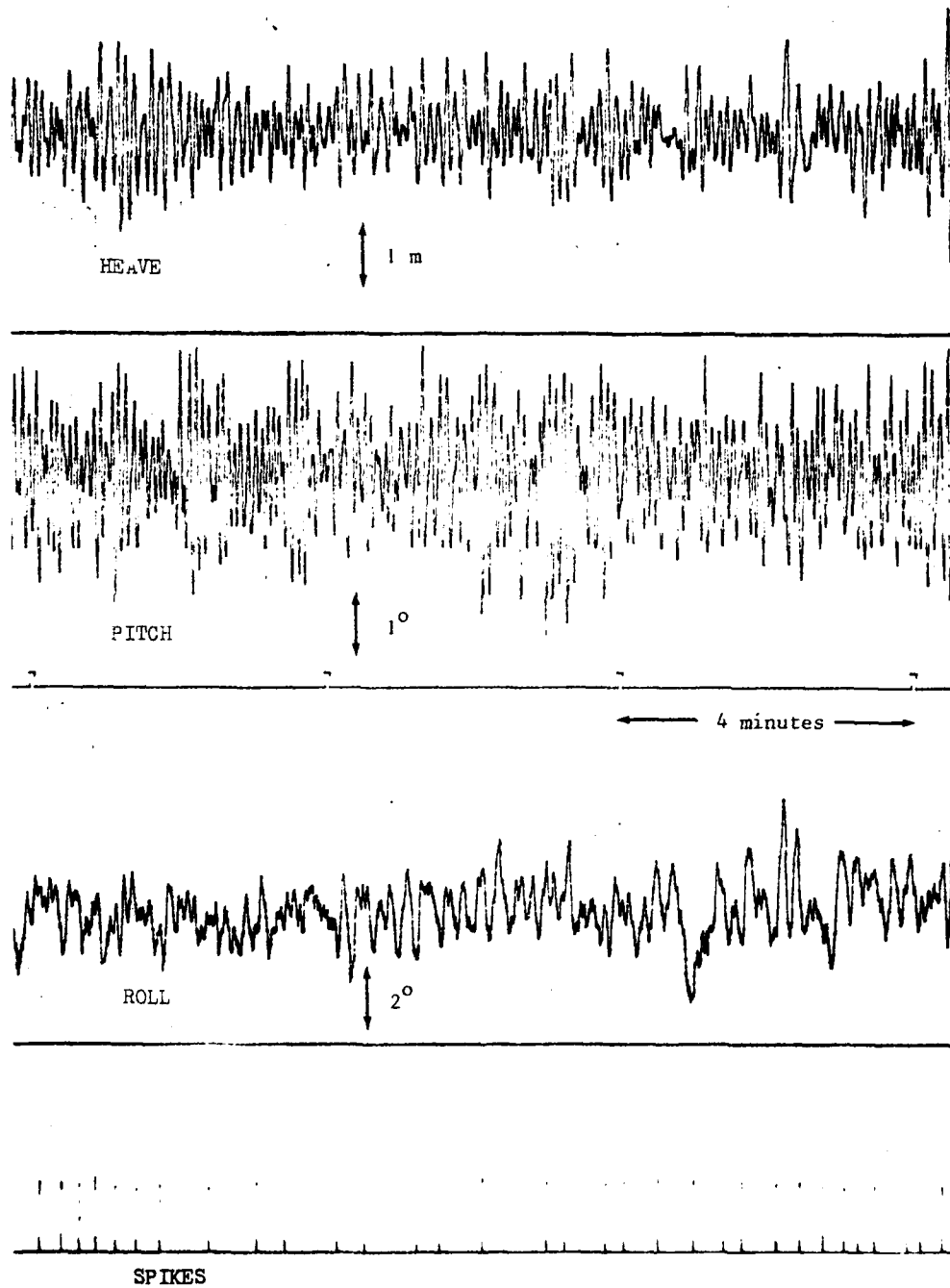

Fig 6 Part of the ship motion recording used to drive the rig and the voltage spikes to control task presentation

TM FS 365

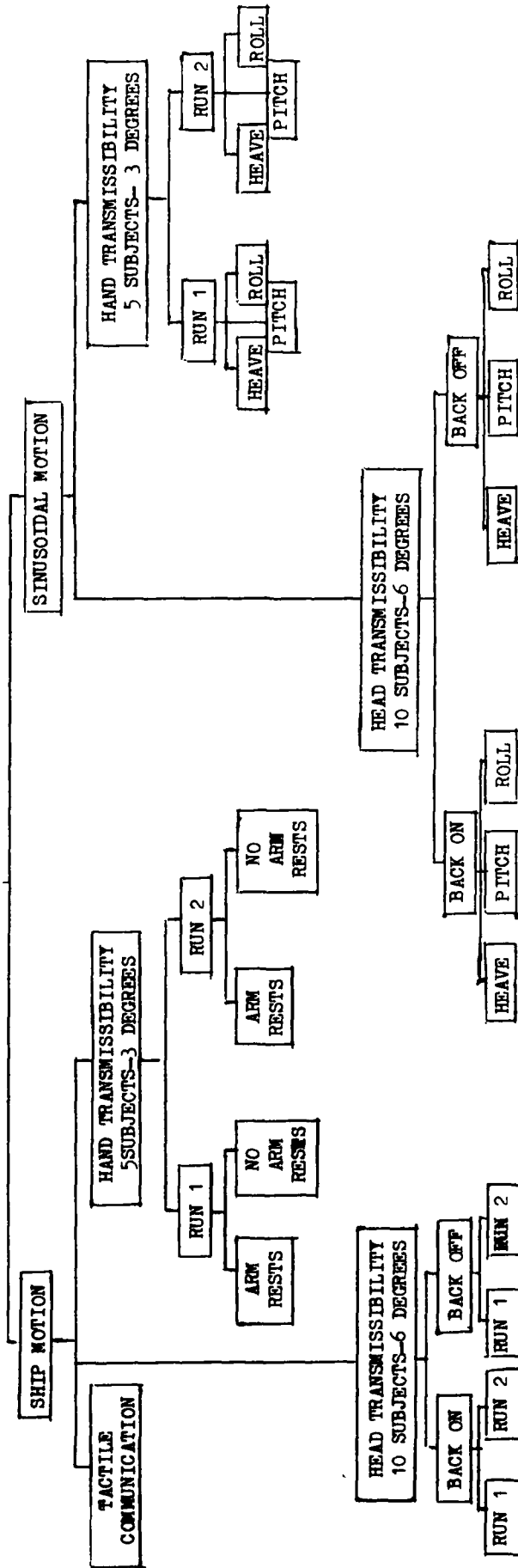

Fig 7 Experimental design schematic

Fig 8

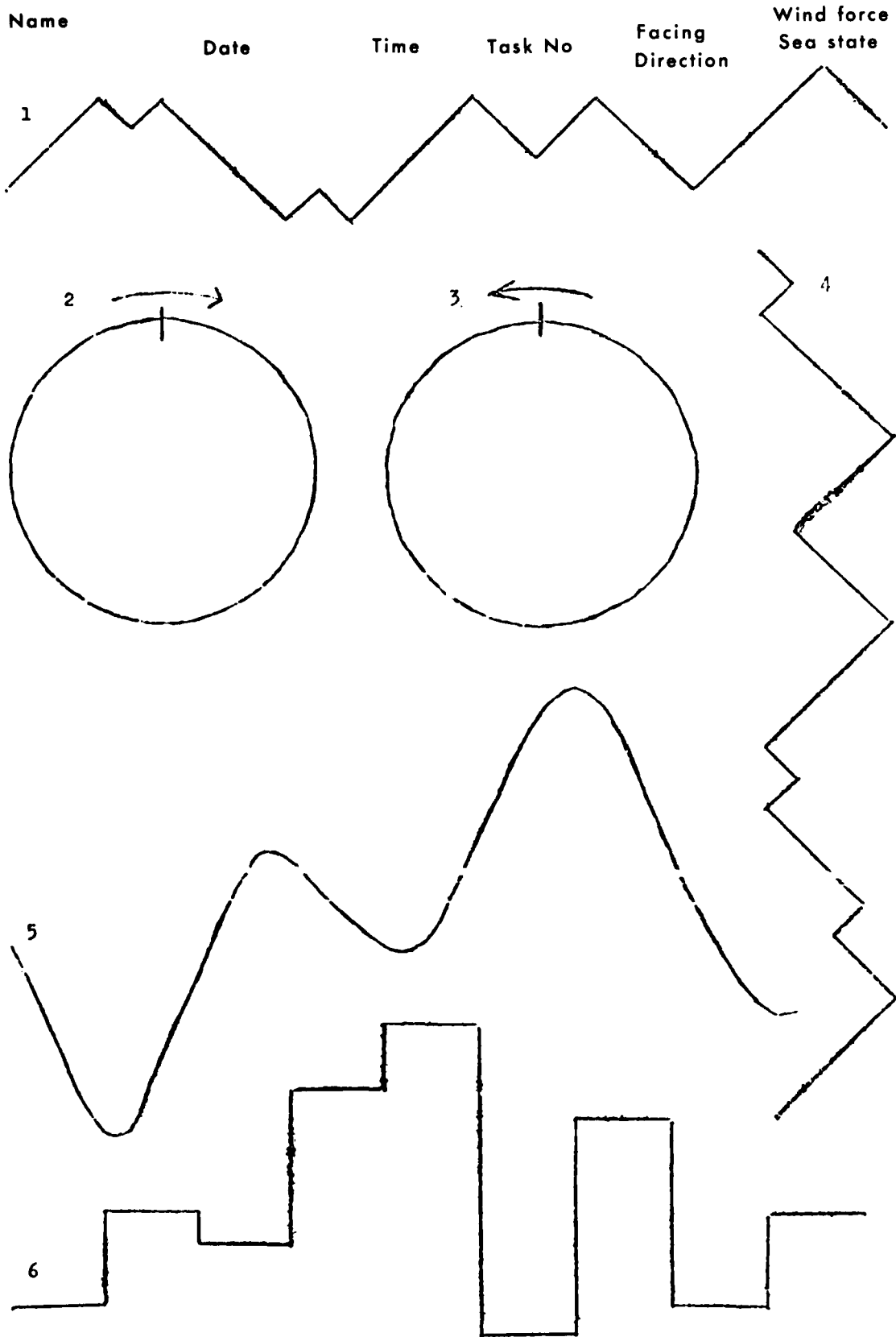

Fig 8 Track tracing chart

lx	Name	Date	Ratings No.
	Performance	_____	
	Much better than usual		Much worse than usual
	Wellbeing	_____	
	Awful about to vomit		Fine
	Dizziness	_____	
	None		Severe
	Skin	_____	
	Dry		Sweaty
	Headache	_____	
	Severe		None
	Stomach awareness	_____	
	None		Severe
	Mouth	_____	
	Watery		Dry
	Vision	_____	
	Blurred		Normal

TM FS 365

Fig 9 Questionnaire

Fig 10

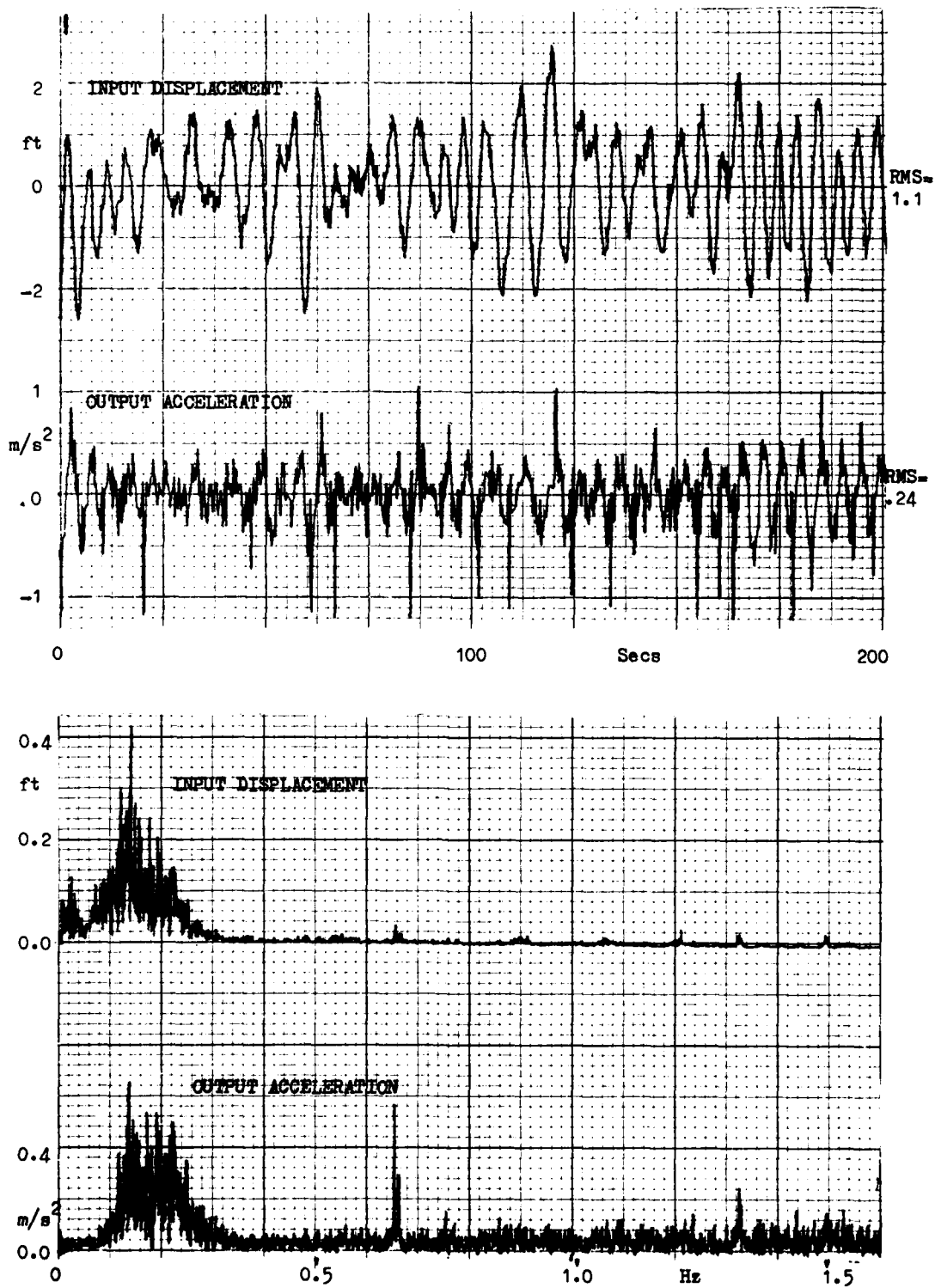

Fig 10 Rig heave input and output waveforms and their spectra (simulated ship motion)

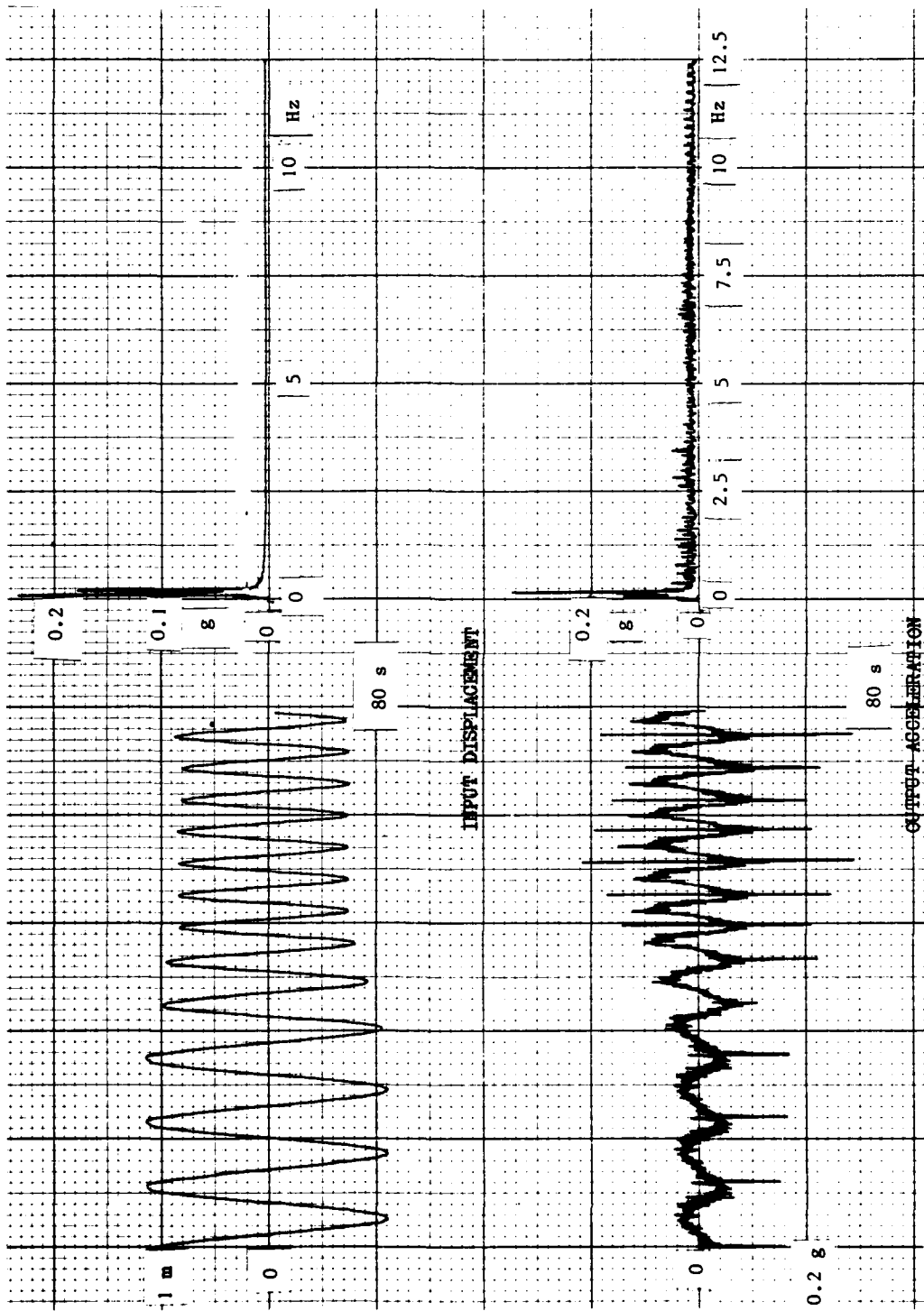

Fig 11 Rig heave input and output waveforms and spectra for simulator (sinusoidal input at 0.1 and 0.2 Hz)

Fig 12a

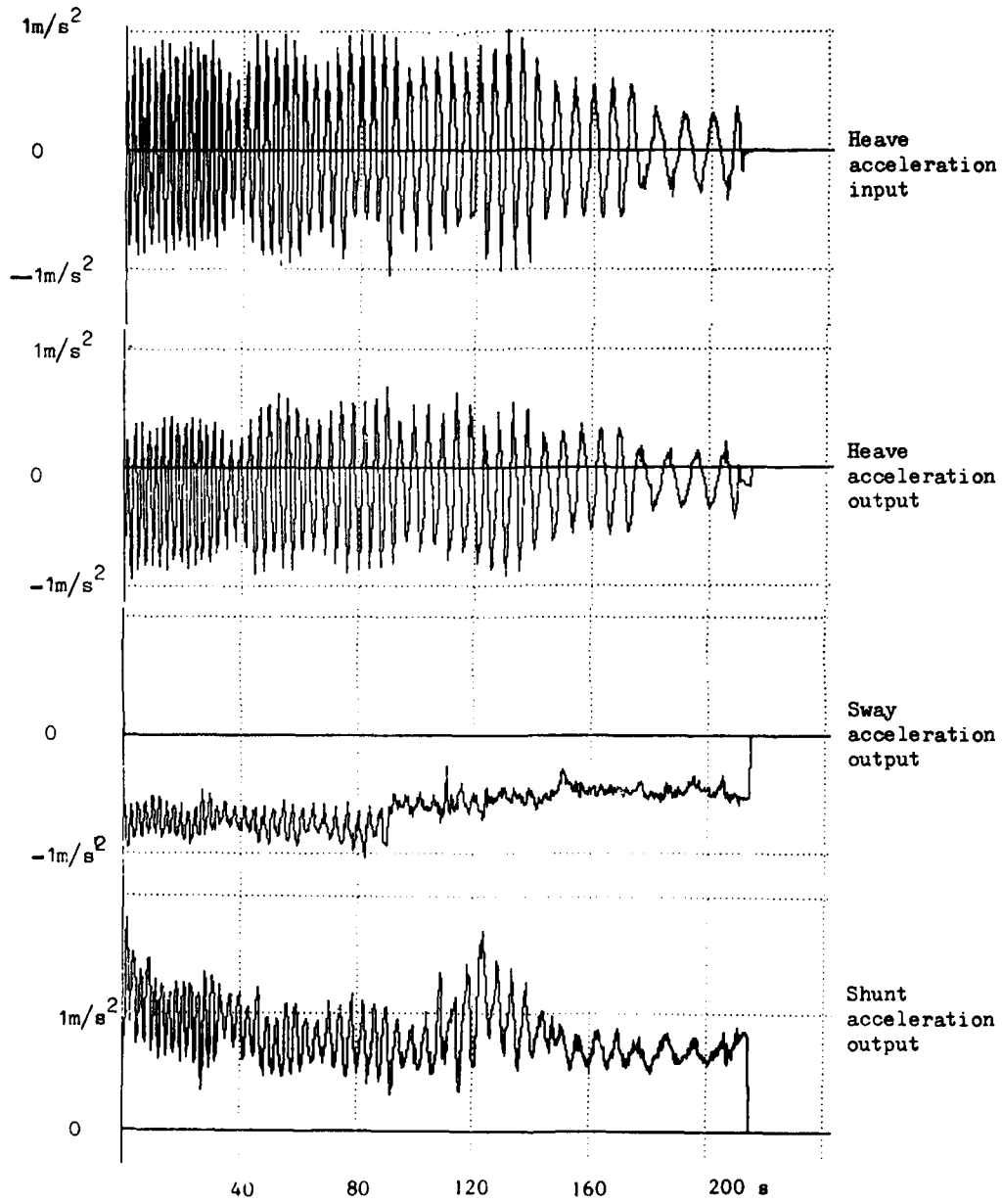

Fig 12a Input and output acceleration bite bar waveforms for typical subject

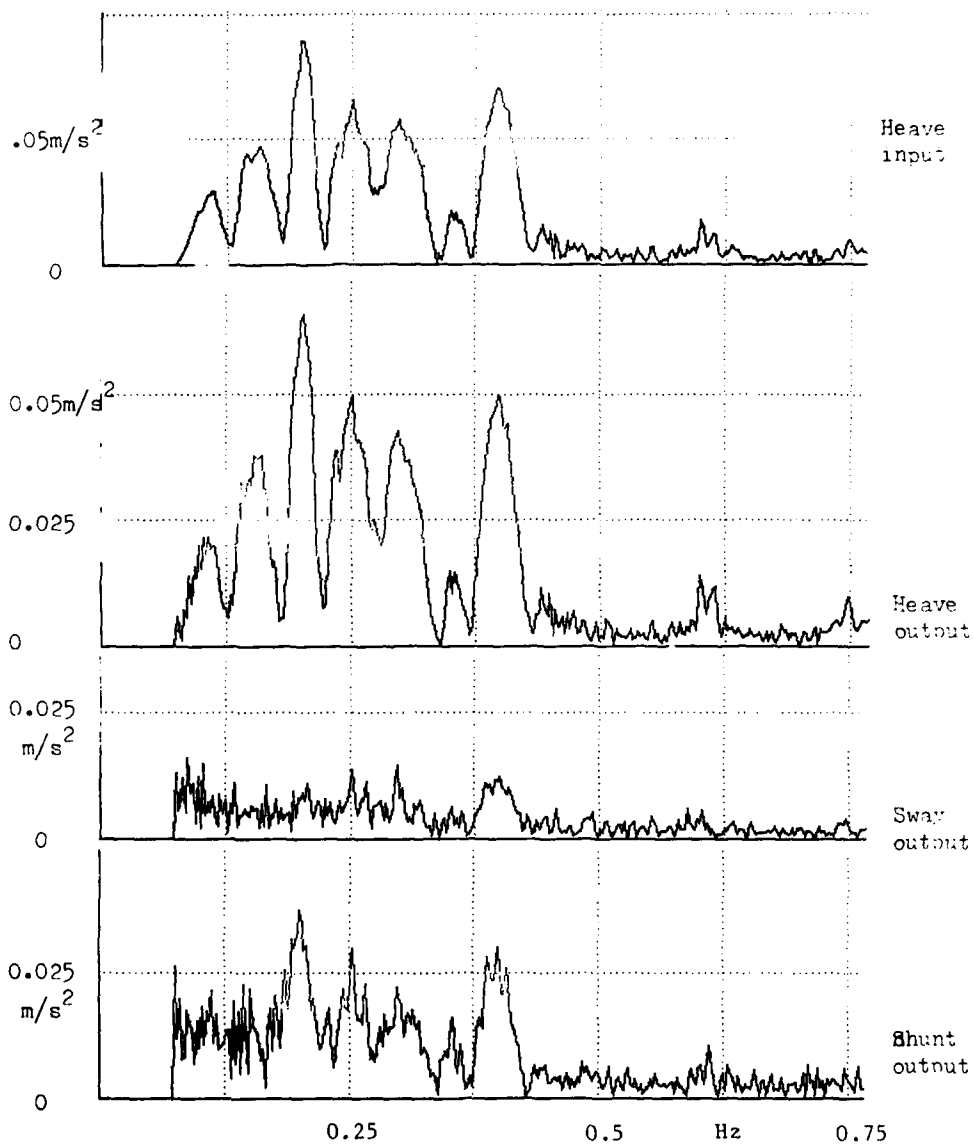

Fig 12b Input and output bite bar spectra for typical subject

Fig 13

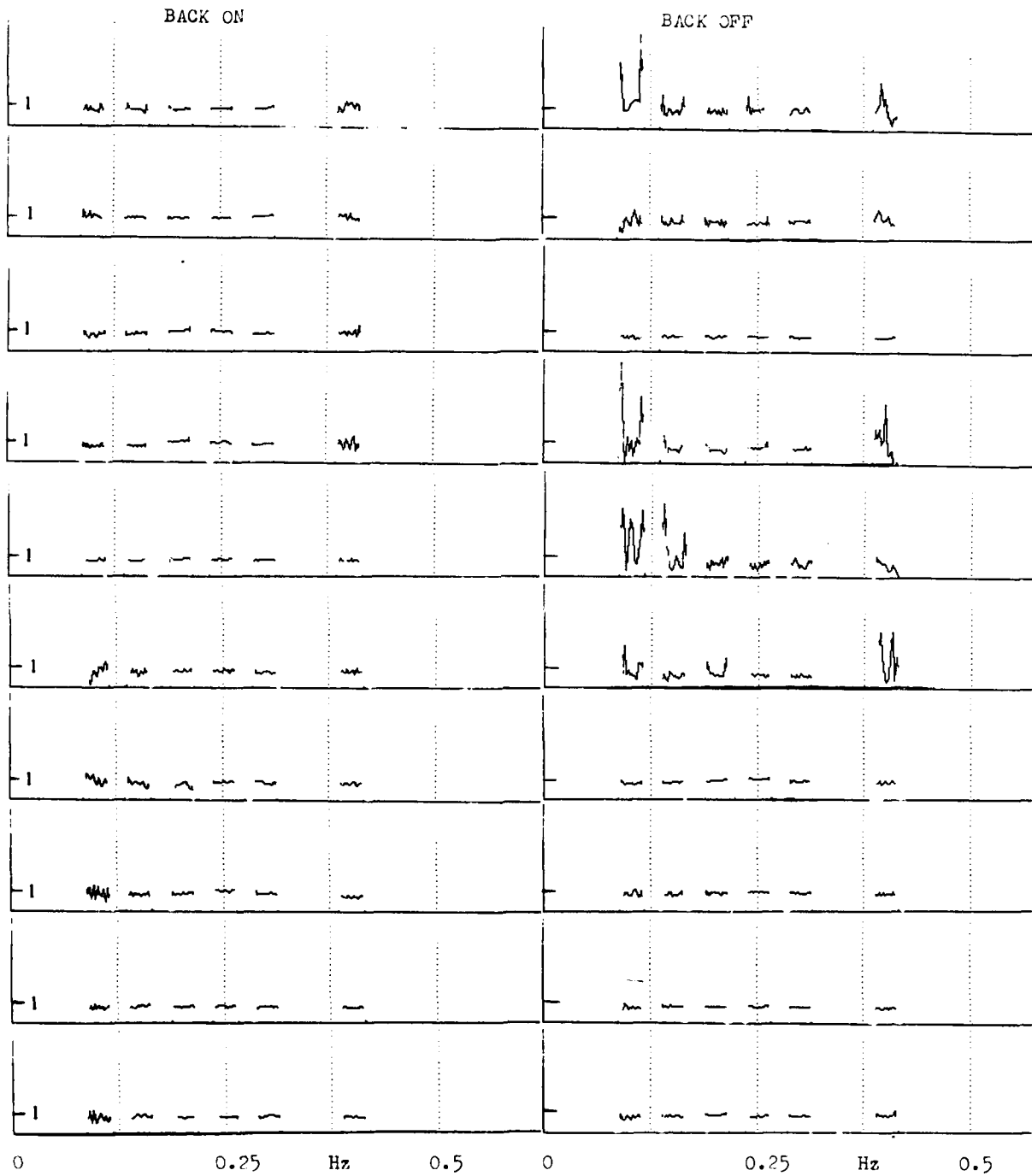

Fig 13 Apparent head transmissibility: heave/heave for back on and back off for ten subjects. (Intermediate frequencies deleted)

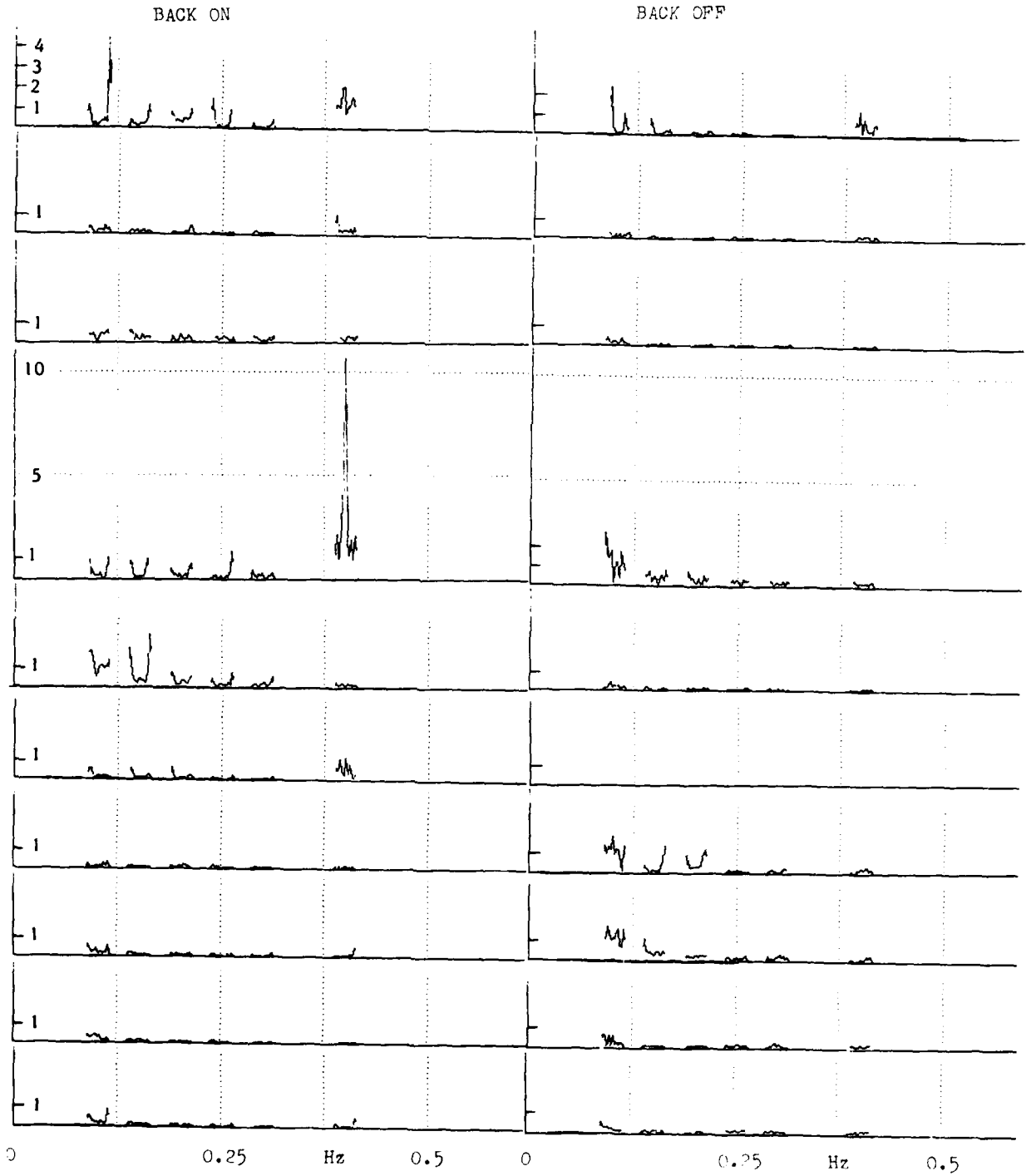

Fig 14 Apparent head transmissibility: sway/heave for back on and back off for ten subjects

Fig 15

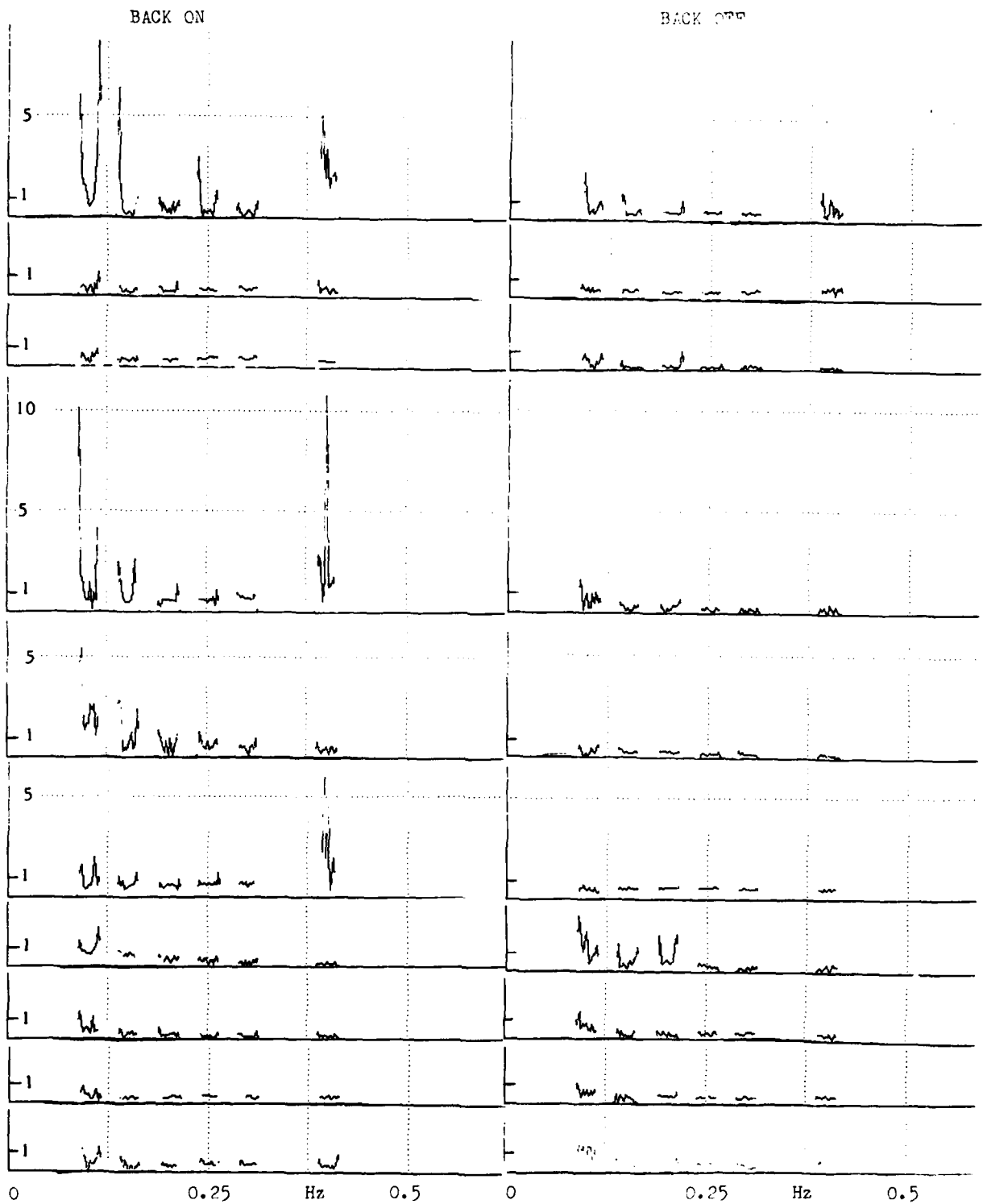

Fig 15 Apparent head transmissibility: shunt/heave for back on and back off for ten subjects

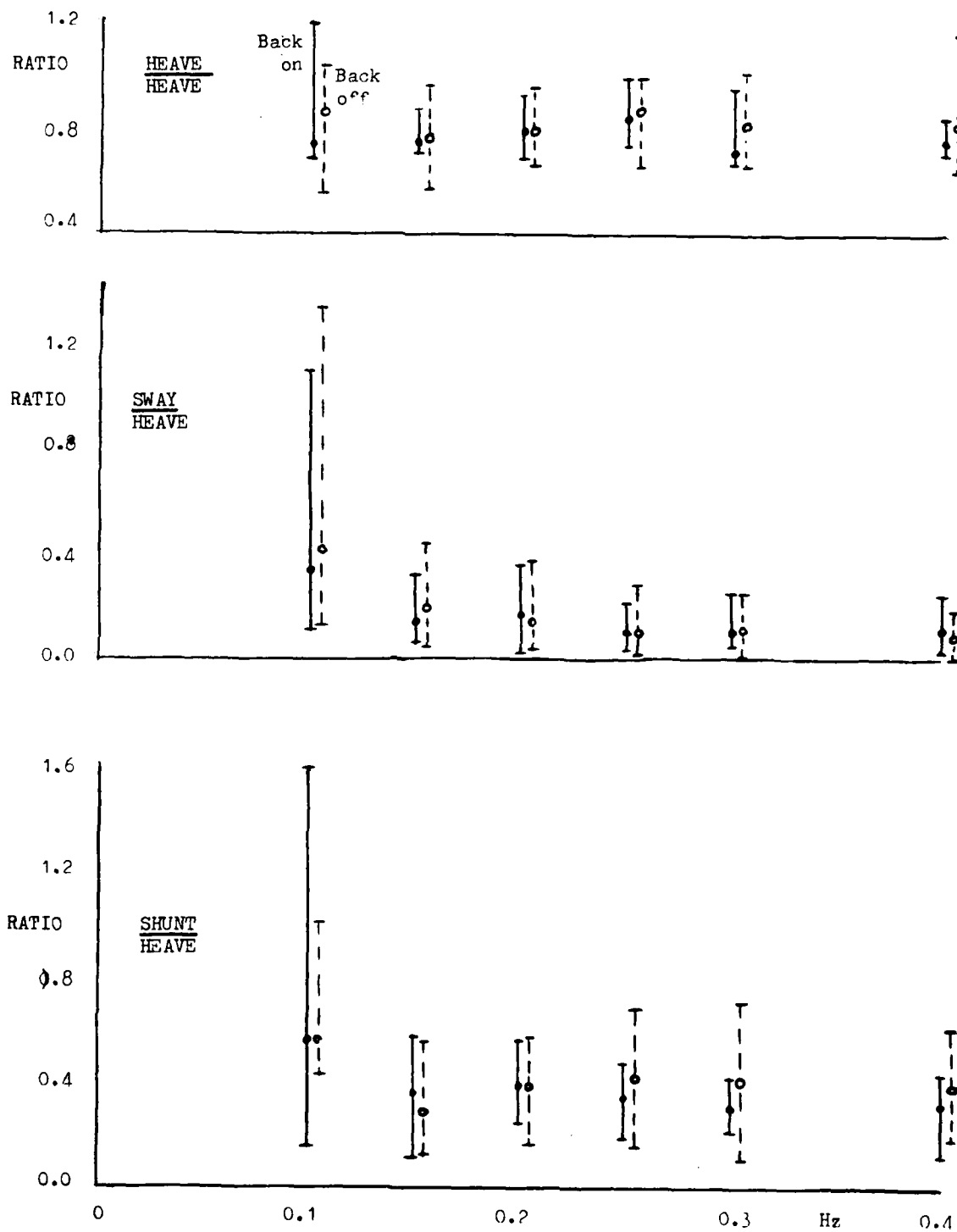

Fig 16 Head transmissibility: mean values and range for specific frequencies, back on and back off (10 subjects)

Fig 17

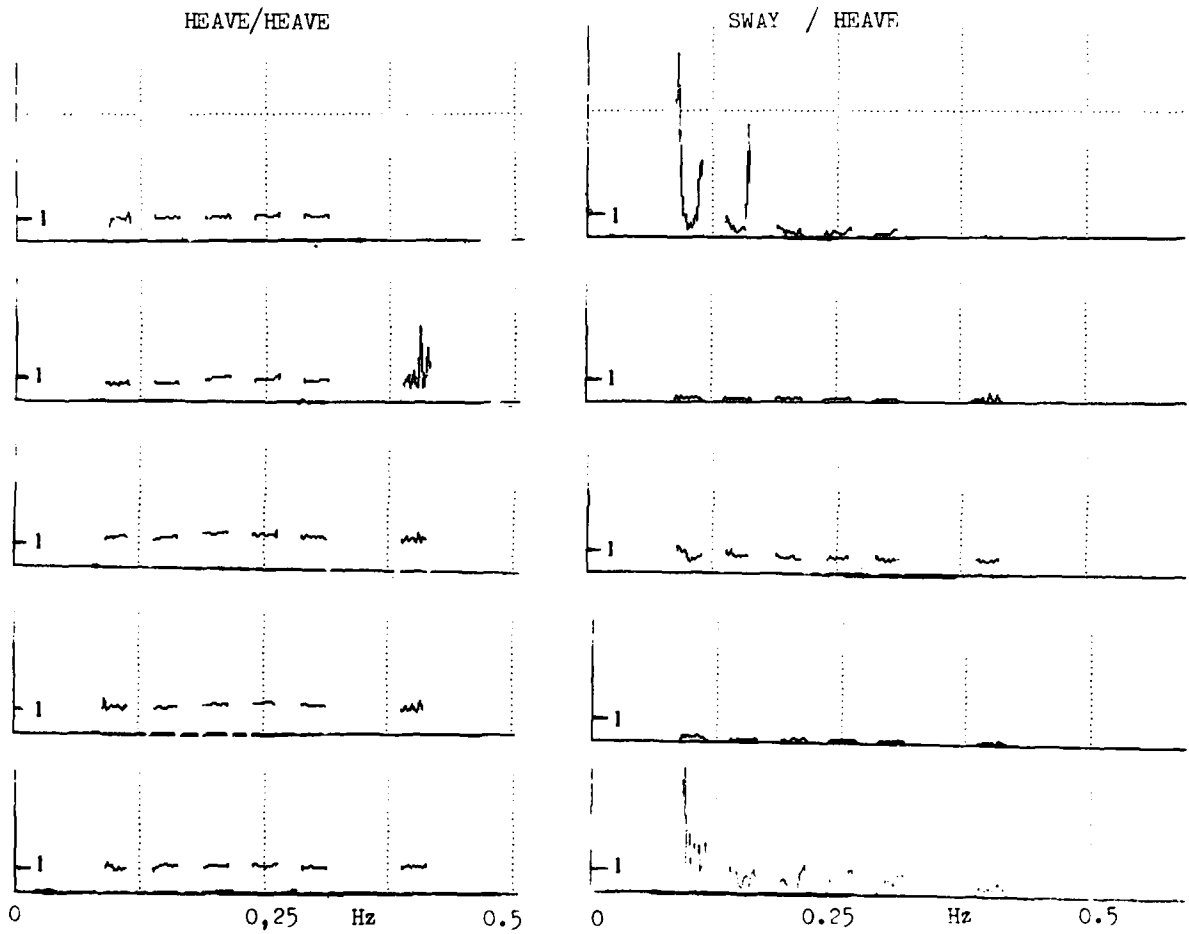

Fig 17 Apparent hand transmissibility: heave/heave and sway/heave for all five subjects. (Intermediate frequencies deleted)

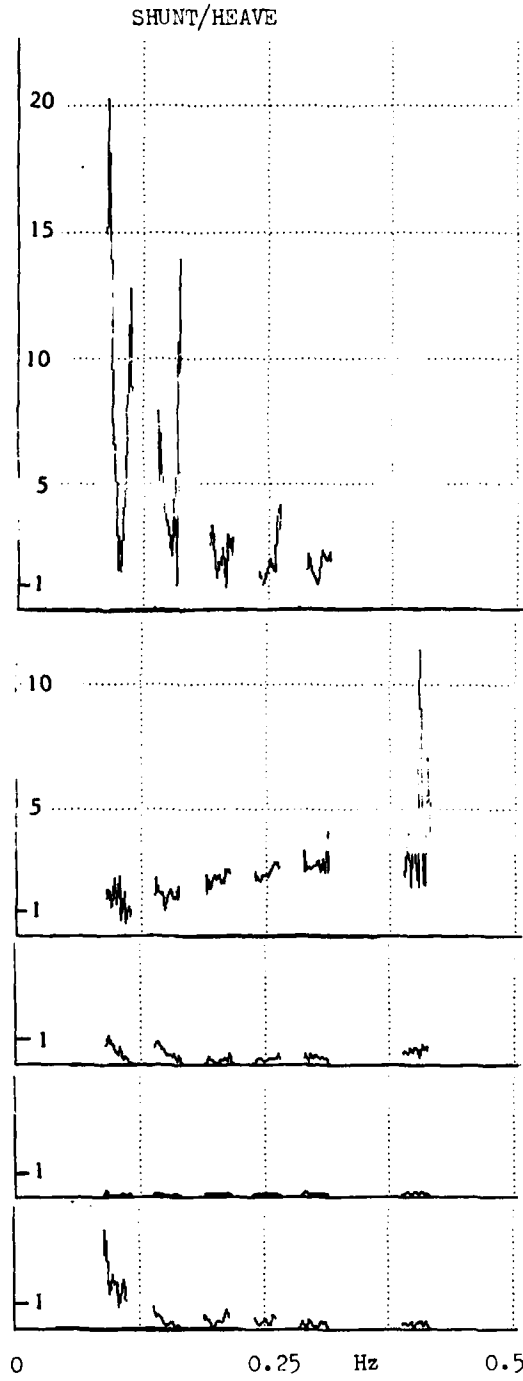

Fig 18 Apparent hand transmissibility: shunt/heave for all five subjects

Fig 19

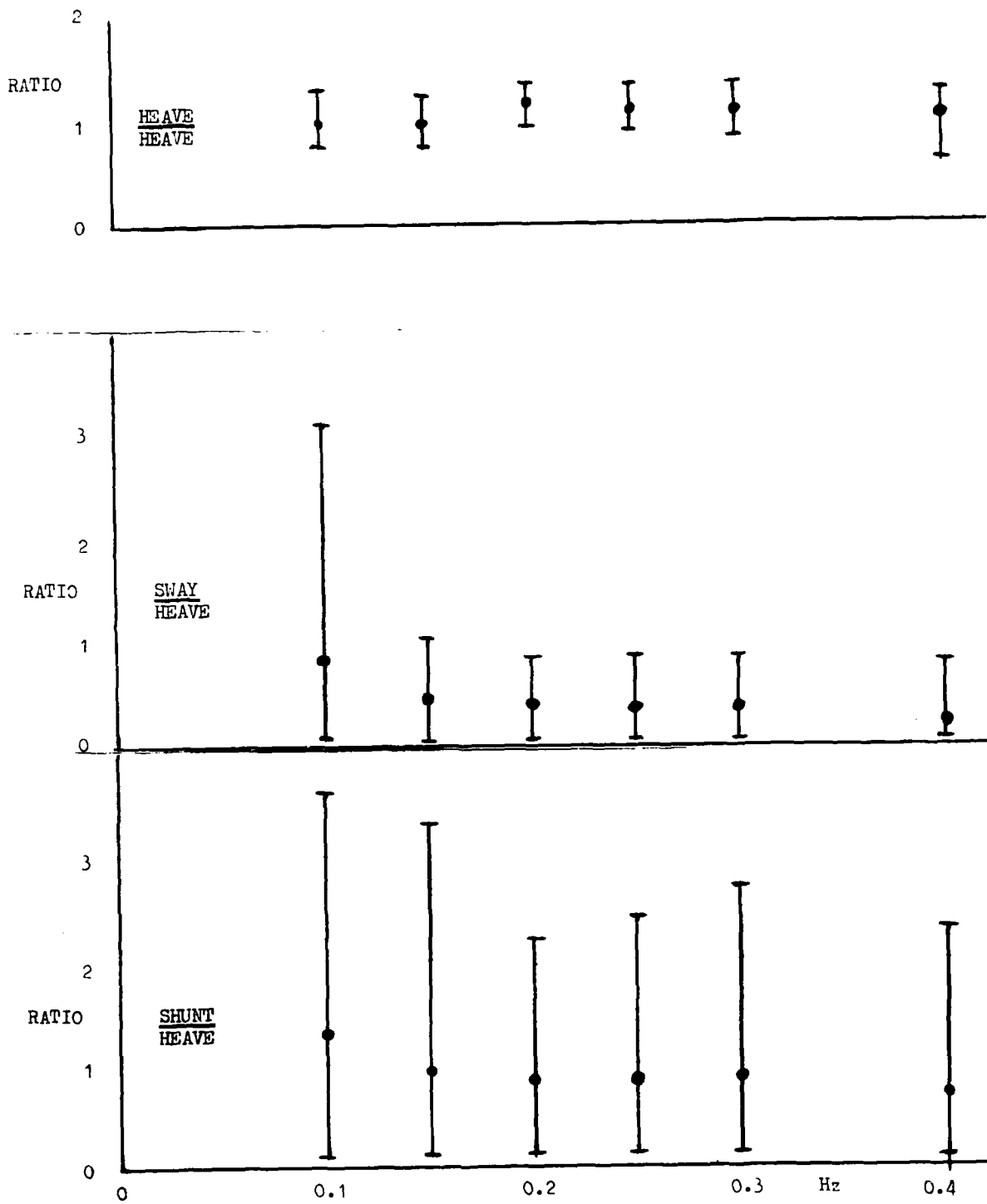

Fig 19 Apparent hand transmissibility: mean values and range at specific input frequencies

REPORT DOCUMENTATION PAGE

Overall security classification of this page

UNCLASSIFIED

As far as possible this page should contain only unclassified information. If it is necessary to enter classified information, the box above must be marked to indicate the classification, e.g. Restricted, Confidential or Secret.

1. DRIC Reference (to be added by DRIC)	2. Originator's Reference RAE TM FS 365	3. Agency Reference N/A	4. Report Security Classification/Marking UNCLASSIFIED
5. DRIC Code for Originator 7673000W	6. Originator (Corporate Author) Name and Location Royal Aircraft Establishment, Farnborough, Hants, UK		
5a. Sponsoring Agency's Code N/A	6a. Sponsoring Agency (Contract Authority) Name and Location N/A		
7. Title Human reaction to low frequency motion - preliminary studies			
7a. (For Translations) Title in Foreign Language			
7b. (For Conference Papers) Title, Place and Date of Conference			
8. Author 1. Surname, Initials du Ross, S.H.	9a. Author 2	9b. Authors 3, 4	10. Date November 1980
			Pages 44
			Refs. 5
11. Contract Number N/A	12. Period N/A	13. Project	14. Other Reference Nos.
15. Distribution statement (a) Controlled by - (b) Special limitations (if any) -			
16. Descriptors (Keywords) (Descriptors marked * are selected from TEST) Low frequency motion. Human performance. Ship motion.			
17. Abstract <p>A preliminary experiment using the Warren Spring Laboratory ship motion simulator to ascertain the effects of low frequency ship and sinusoidal motion on man and his performance is described. The ship motion signals were based on those recorded from HMS Avenger at 25 kn into a force 4 wind. Sinusoidal motion was in heave, pitch, and roll for frequencies from 0.1-0.4 Hz.</p> <p>A tracing task involving unsupported arm movements was seriously affected by the motion; a tracking task showed a small decrement in performance and a digit keying task was unaffected. There was no evidence that adverse effects were caused by motion sickness. Accelerations were measured at the head and hand of each subject and compared to the input accelerations. The resulting transmissibilities showed that relatively large rotational motions could be induced.</p> <p>The simulator required extensive modifications to its mechanical, hydraulic and electronic systems in order that it could safely be used for human subjects. Notwithstanding these modifications to the simulator exhibited undesirable cross-axis movements which may have a bearing on the results. The experiment also showed that more sophisticated measurements were necessary to accurately describe resulting biodynamic behaviour.</p>			