

AD-A096 393

NAVAL POSTGRADUATE SCHOOL MONTEREY CA
SENSITIVITY OF THE STEADY-STATE KALMAN FILTERS TO STABILITY DER--ETC(U)
SEP 80 J A MATALLANA R.

F/G 17/7

UNCLASSIFIED

NL

1 of 2
ADA
1988 SPA

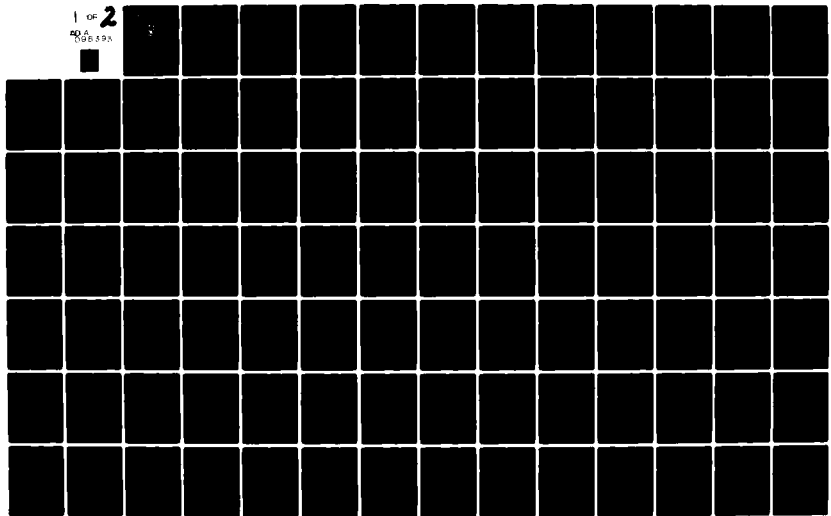

2

NAVAL POSTGRADUATE SCHOOL

Monterey, California

AD A 096393



THESIS

SENSITIVITY OF THE STEADY-STATE
KALMAN FILTERS TO STABILITY DERIVATIVES
VARIATIONS IN AN INERTIAL NAVIGATION SYSTEM

by

Jose Augusto Matallana R.

September 1980

Thesis Advisor:

Daniel J. Collins

SELECTED
MAR 16 1981

A

Approved for public release; distribution unlimited

USG FILE COPY

81 3 16 080

Unclassified

SECURITY CLASSIFICATION OF THIS PAGE (When Data Entered)

REPORT DOCUMENTATION PAGE		READ INSTRUCTIONS BEFORE COMPLETING FORM	
1. REPORT NUMBER	2. GOVT ACCESSION NO.	3. RECIPIENT'S CATALOG NUMBER	
	AD A096	393	
4. TITLE (and Subtitle)		5. TYPE OF REPORT & PERIOD COVERED	
Sensitivity of the Steady-State Kalman Filters to Stability Derivatives Variations in an Inertial Navigation System.		9) Master's Thesis September 1980	
7. AUTHOR(s)		8. CONTRACT OR GRANT NUMBER(s)	
10) Jose Augusto Matallana R.			
9. PERFORMING ORGANIZATION NAME AND ADDRESS		10. PROGRAM ELEMENT, PROJECT, TASK AREA & WORK UNIT NUMBERS	
Naval Postgraduate School Monterey, California 93940			
11. CONTROLLING OFFICE NAME AND ADDRESS		12. REPORT DATE	
Naval Postgraduate School Monterey, California 93940		(12) 103, (11) Sep 1980	
14. MONITORING AGENCY NAME & ADDRESS (if different from Controlling Office)		13. NUMBER OF PAGES	
Naval Postgraduate School Monterey, California 93940		102	
		15. SECURITY CLASS. (of this report)	
		Unclassified	
		15a. DECLASSIFICATION/DOWNGRADING SCHEDULE	
16. DISTRIBUTION STATEMENT (of this Report)			
Approved for public release; distribution unlimited			
17. DISTRIBUTION STATEMENT (of the abstract entered in Block 20, if different from Report)			
Approved for public release; distribution unlimited			
18. SUPPLEMENTARY NOTES			
19. KEY WORDS (Continue on reverse side if necessary and identify by block number)			
Inertial Navigation System (INS) Steady-State Kalman Filter (SKF) Stability Derivatives (SD)			
20. ABSTRACT (Continue on reverse side if necessary and identify by block number)			
In a tactical missile with mid-course guidance, an Inertial Navigation System (INS) is required. Strapdown INS using Steady-State Kalman Filters (SKF) as estimators has been suggested and this kind of INS is considered to be easier and cheaper to implement than the gimballed INS. This thesis investigates one aspect of the INS problem: The sensitivity of the SKF to inaccuracies in the filter parameters such			

Unclassified

SECURITY CLASSIFICATION OF THIS PAGE/When Data Entered

as the stability derivatives. The analysis has been performed by varying each of the flight parameters over a given range and noting the effect on the accuracy of the filter. The great advantage of the analysis in the sensitivity of rms estimate errors to inaccuracies in the stability derivatives is that it points out clearly which derivatives are worthy of detailed accurate determination and which are not.

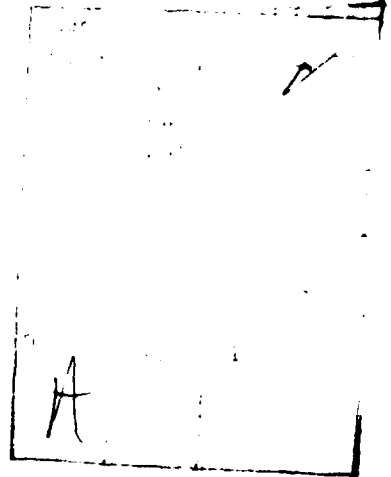

Unclassified

SECURITY CLASSIFICATION OF THIS PAGE/When Data Entered

Approved for public release; distribution unlimited

Sensitivity of the Steady-State
Kalman Filters to Stability Derivatives
Variations in an Inertial Navigation System

by

Jose Augusto Matallana R.
Lieutenant, Colombian Navy

Submitted in partial fulfillment of the
requirements for the degree of

MASTER OF SCIENCE IN ELECTRICAL ENGINEERING

from the

NAVAL POSTGRADUATE SCHOOL
September 1980

Author

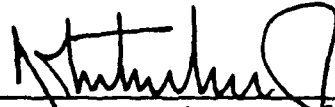

Approved by:

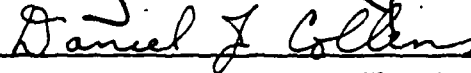

Thesis Advisor



Second Reader



Chairman, Department of Electrical Engineering



Dean of Science and Engineering

ABSTRACT

In a tactical missile with mid-course guidance, an Inertial Navigation System (INS) is required. Strapdown INS using Steady-State Kalman Filters (SKF) as estimators has been suggested and this kind of INS is considered to be easier and cheaper to implement than the gimbaled INS.

This thesis investigates one aspect of the INS problem: The sensitivity of the SKF to inaccuracies in the filter parameters such as the stability derivatives. The analysis has been performed by varying each of the flight parameters over a given range and noting the effect on the accuracy of the filter. The great advantage of the analysis in the sensitivity of rms estimate errors to inaccuracies in the stability derivatives is that it points out clearly which derivatives are worthy of detailed accurate determination and which are not.

TABLE OF CONTENTS

I.	INTRODUCTION -----	11
II.	STOCHASTIC MODELS AND ESTIMATION -----	13
A.	A. KALMAN FILTER -----	13
	1. Linear Dynamic System -----	13
	2. Continuous Time Kalman Filter -----	14
	B. STATE AUGMENTATION AND SHAPING FILTERS -----	16
	C. SENSITIVITY TO PARAMETER VARIATION -----	17
	1. Incorrect Implementation of Dynamics -----	18
	D. MODAL COORDINATES TRANSFORMATION -----	20
	E. SOLUTION OF THE KALMAN FILTER WITH A PRESCRIBED DEGREE OF STABILITY -----	21
III.	DYNAMIC AND MEASUREMENT SYSTEM MODELS -----	23
	A. REFERENCE AXIS SYSTEM -----	23
	B. MISSILE EQUATIONS OF MOTION -----	24
	1. Longitudinal Motion -----	24
	2. Lateral Motion -----	24
	C. MODEL -----	25
	1. Longitudinal Motion Estimation -----	25
	2. Lateral Motion Estimation -----	27
IV.	ANALYSIS -----	29
	A. THE SIMULATION -----	29
	B. THE RESULTS -----	29
	1. Longitudinal Motion Estimation Analysis ----	30
	2. Lateral Motion Estimation Analysis -----	34

V. CONCLUSIONS AND RECOMMENDATIONS -----	77
VI. SUMMARY -----	81
APPENDIX A: LIST OF SYMBOLS -----	83
APPENDIX B: AERODYNAMIC DATA AND PROBABILISTIC INFORMATION -----	85
COMPUTER OUTPUT -----	87
COMPUTER PROGRAM -----	95
LIST OF REFERENCES -----	101
INITIAL DISTRIBUTION LIST -----	102

LIST OF FIGURES

FIGURE 1:	System Model and Kalman Filter -----	14
FIGURE 2:	Shaping Filter Generating Driving Noise. Conformation of the Augmented System -----	17
FIGURE 3:	Block Diagram of the System and Kalman Filter with Incorrect Implementation of Dynamics -----	18
FIGURE 4:	Reference Axis System -----	23
FIGURES 5;6:	Sensitivity of \bar{u} and \bar{h} rms Estimate Errors vs Variation in X_u stability derivative --	41
FIGURES 7;8:	Sensitivity of \bar{u} and \bar{h} rms Estimate Errors vs Variation in X_w stability derivative --	42
FIGURES 9;10:	Sensitivity of \bar{u} and \bar{w} rms Estimate Errors vs Variation in Z_w Stability Derivative --	43
FIGURES 11;12:	Sensitivity of \bar{h} and $\bar{\theta}$ rms Estimate Errors vs Variation in Z_u Stability Derivative --	44
FIGURES 13;14:	Sensitivity of \bar{w}_g and \bar{u}_g rms Estimate Errors vs Variation of Z_u Stability Derivative -----	45
FIGURES 15;16:	Sensitivity of \bar{u} and \bar{w} rms Estimate Errors vs Variation in Z_w Stability Derivative --	46
FIGURES 17;18:	Sensitivity of \bar{q} and $\bar{\theta}$ rms Estimate Errors vs Variation in Z_w Stability Derivative --	47
FIGURES 19;20:	Sensitivity of \bar{h} and \bar{u}_g rms Estimate Errors vs Variation in Z_w Stability Derivative --	48
FIGURES 21;22:	Sensitivity of \bar{u} and \bar{w} rms Estimate Errors vs Variation in M_u Stability Derivative --	49
FIGURES 23;24:	Sensitivity of $\bar{\theta}$ and \bar{h} rms Estimate Errors vs Variation in M_u Stability Derivative --	50
FIGURES 25;26:	Sensitivity of \bar{w}_g and \bar{u}_g rms Estimate Errors vs Variation in M_u Stability Derivative -----	51

FIGURES 27;28:	Sensitivity of \bar{u} and \bar{w} rms Estimate Errors vs Variation in M_w Stability Derivative --	52
FIGURES 29;30:	Sensitivity of \bar{q} and $\bar{\theta}$ rms Estimate Errors vs Variation in M_w Stability Derivative --	53
FIGURES 31;32:	Sensitivity of \bar{h} and \bar{w}_g rms Estimate Errors vs Variation in M_w Stability Derivative --	54
FIGURES 33;34:	Sensitivity of \bar{u} and \bar{h} rms Estimate Errors vs Variation in M_q Stability Derivative --	55
FIGURES 35;36:	Sensitivity of u and w rms Estimate Errors vs Variation in M_w Stability Derivative --	56
FIGURES 37;38:	Sensitivity of \bar{q} and $\bar{\theta}$ rms Estimate Errors vs Variation in M_w Stability Derivative --	57
FIGURES 39;40:	Sensitivity of \bar{h} and \bar{w}_g rms Estimate Errors vs Variation of M_w Stability Derivative --	58
FIGURES 41;42:	Sensitivity of V_{β} and \bar{p} rms Estimate Errors vs Variation in Y_v Stability Derivative --	59
FIGURES 43;44:	Sensitivity of $\bar{\theta}$ and $V_{\beta g}$ rms Estimate Errors vs Variation in Y_v Stability Derivative --	60
FIGURES 45;46:	Sensitivity of V_{β} and \bar{r} rms Estimate Errors vs Variation in N_{β} Stability Derivative --	61
FIGURES 47;48:	Sensitivity of \bar{p} and $\bar{\theta}$ rms Estimate Errors vs Variation of N_{β} Stability Derivative --	62
FIGURES 49;50:	Sensitivity of $\bar{\psi}$ and $V_{\beta g}$ rms Estimate Errors vs Variation in N_{β} Stability Derivative --	63
FIGURES 51;52:	Sensitivity of V_{β} and \bar{r} rms Estimate Errors vs Variation in N_r Stability Derivative --	64
FIGURES 53;54:	Sensitivity of $\bar{\theta}$ and V_g rms Estimate Errors vs Variation in N_r Stability Derivative --	65
FIGURES 55;56:	Sensitivity of V_{β} and \bar{r} rms Estimate Errors vs Variation in N_p Stability Derivative --	66
FIGURES 57;58:	Sensitivity of \bar{p} and $\bar{\theta}$ rms Estimate Errors vs Variation of N_p Stability Derivative --	67
FIGURES 59;60:	Sensitivity of $\bar{\psi}$ and $V_{\beta g}$ rms Estimate Errors vs Variation in N_p Stability Derivative --	68

FIGURES 61;62:	Sensitivity of V_{β}^{-} and \bar{r} rms Estimate Errors vs Variation in L'_{β} Stability Derivative ---	69
FIGURES 63;64:	Sensitivity of \bar{p} and $\bar{\theta}$ rms Estimate Errors vs Variation in L'_{β} Stability Derivative ---	70
FIGURES 65;66:	Sensitivity of $\bar{\psi}$ and $V_{\beta g}$ rms Estimate Errors vs Variation in L'_{β} Stability Derivative ---	71
FIGURES 67;68:	Sensitivity of V_{β}^{-} and \bar{r} rms Estimate Errors vs Variation of L'_{r} Stability Derivative ---	72
FIGURES 69;70:	Sensitivity of \bar{p} and $\bar{\theta}$ rms Estimate Errors vs Variation of L'_{r} Stability Derivative ---	73
FIGURES 71;72:	Sensitivity of $\bar{\psi}$ and $V_{\beta g}$ rms Estimate Errors vs Variation of L'_{r} Stability Derivative ---	74
FIGURES 73;74:	Sensitivity of V_{β}^{-} and \bar{r} rms Estimate Errors vs Variation in L'_{p} Stability Derivative ---	75
FIGURES 75;76:	Sensitivity of $\bar{\theta}$ and $V_{\beta g}$ rms Estimate Errors vs Variation in L'_{p} Stability Derivative ---	76

ACKNOWLEDGEMENT

I would like to express my gratitude to Dr. D. J. Collins for his assistance, guidance and continuous encouragement which he provided during the pursuit of this study. To my wife I would like to offer my thanks and love for her patience, understanding and fortitude during a time which tested both of us.

JOSE A MATALLANA

I. INTRODUCTION

In a typical tactical missile trajectory, standoff (or mid-course) guidance is required when the missile is launched at such long ranges from the target that either the missile seeker cannot detect the target or, if it can, the information is of such poor quality that is unusable. The mid-course guidance law usually consists of some pre-programed strategy such as to maintain the launch heading, constant altitude and speed. Mid-course guidance is primarily an inertial instrumentation problem. Typical sensors onboard missiles consist of three rate gyros (pitch, yaw and roll), accelerometers, sometimes magnetic compass and some kind of altimeter. Additional state information can be provided by the seeker. A radar seeker could provide range and range rate.

Here is considered the problem of using steady-state Kalman Filters as part of a navigation system, where the two estimators together (longitudinal and lateral estimators), constitute a strapdown system that does not use accelerometers or gimbaled gyros. Strapdown Inertial Navigation Systems (INS) using Steady-State Kalman Filters (SKF) as estimators have been considered as cheaper and easier to implement than the gimbaled INS. The sensors used in this analysis are: pitch and roll rate gyros, altimeter and magnetic compass. Since constant gain estimators have been

suggested as easier and cheaper to implement, the analysis is confined to the SKF.

This work has been motivated by the idea given in Ref. [4], where the author discusses in detail the configuration of such a navigation system as described before, but the problem is presented as a particular application in the INS of the DC-8 airplane. For convenience the model used here essentially is the same as Ref. [4] in lieu of a missile. This was done in order to eliminate classification problems.

This thesis investigates only one aspect of the INS problem. That aspect is the sensitivity of the Kalman Filter to inaccuracies in the filter parameters or variation between the filter model and the plant model. These differences can be due to either inaccuracies as indicated or to a normal variation in the flight parameters due to different flight regimes. One result of this is the sensitivity of rms estimate errors to inaccuracies or differences in the stability derivatives.

The work was begun by reproducing the results given in Ref. [4] with the correct implementation of the dynamics in the filter parameters (i.e., X_u , Y_v , etc.) over a given range and noting the effect on the accuracy of the filter.

II. STOCHASTIC MODELS AND ESTIMATION

A. KALMAN FILTER

The Kalman Filter is widely documented and no attempt at a development of general theory has been made in this work. A brief description has been included in order to establish the particular formulation used. For a more complete development one is referred to Ref [1].

1. Linear Dynamic System

The formulation used employs state-space notation which offers the advantage of mathematical and notational convenience. Consider the linear time invariant system (system and measurement models) given by equation (1), where x represents the states of the system; z is the

$$\dot{x} = Fx + \Gamma w \quad (1-a)$$

$$z = Hx + v \quad (1-b)$$

measurement vector; F is the system matrix; Γ is the driving noise coefficient matrix; H describes the relationship between the states and the measurement; w and v are independent, zero-mean white gaussian noise process with covariance matrices Q and R respectively, that in mathematical terms are given by:

$$E(w(t)w^T(\tau)) = Q(t)\delta(t-\tau), \quad E(w(t)) = 0 \quad (2-a)$$

$$E(v(t)v^T(\tau)) = R(t)\delta(t-\tau), \quad E(v(t)) = 0 \quad (2-b)$$

2. Continuous Time Kalman Filter

A continuous time Kalman Filter is described by equation (3), where \hat{x} is the state estimate; K is a matrix of constant filter gains. The implementation of the System Model and the Kalman Filter is shown in block diagram in Figure 1.

$$\dot{\hat{x}} = F\hat{x} + K(z - H\hat{x}) \quad (3)$$

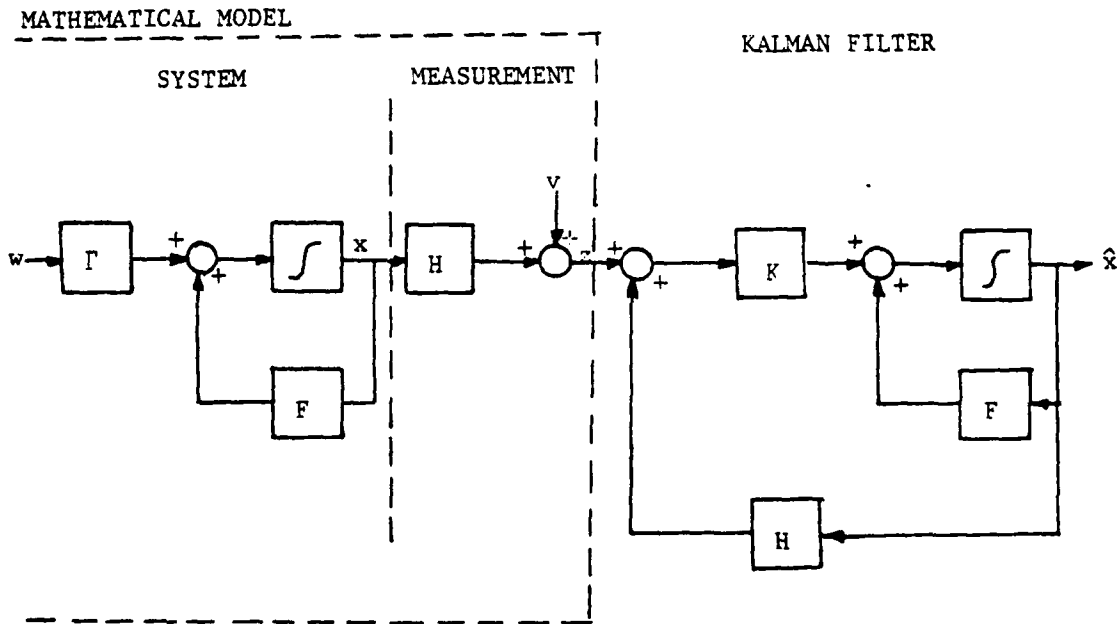

Figure 1
System Model and Kalman Filter

The estimate error is defined by equation (4) as,

$$\tilde{x} \triangleq \hat{x} - x \quad (4)$$

and the differential equation for \tilde{x} is given by

$$\dot{\tilde{x}} = (F-KH)\tilde{x} - \Gamma w + Kv \quad (5)$$

The differential equations for the state of a linear system driven by white noise can be expressed as

$$\begin{bmatrix} \dot{\tilde{x}} \\ \tilde{x} \\ \dot{\tilde{x}} \\ \tilde{x} \end{bmatrix} = \begin{bmatrix} F-KH & | & 0 \\ \hline 0 & | & F \end{bmatrix} \begin{bmatrix} \tilde{x} \\ x \end{bmatrix} + \begin{bmatrix} Kv-\Gamma w \\ \Gamma w \end{bmatrix} \quad (6)$$

The covariance of the estimate-error, designated P, is given by equation (7). It provides a statistical measure of the uncertainty in x.

$$P = E[\tilde{x}\tilde{x}^T] \quad (7)$$

The diagonal elements of the covariance matrix are the mean square errors in the knowledge of the state variables. Also, the trace of P is the mean square length of the vector \tilde{x} . The off diagonal terms of P are indicators of cross-correlation between the elements of \tilde{x} . The covariance matrix P is obtained by solving the linear Lyapunov equation given by

$$P = (F-KH)P + P(F-KH)^T + \Gamma Q \Gamma^T + K R K^T \quad (8)$$

The eigenvalues of the filter are the roots of equation (9).

$$|SI - F + KH| = 0 \quad (9)$$

B. STATE AUGMENTATION AND SHAPING FILTERS

When the system random disturbances are correlated in time, i.e., colored noise, it is necessary to use their power spectral density data in order to develop a mathematical model that produces an output which duplicates the noise characteristics [Ref. 2]. Correlated random noises are taken to be state variables of a fictitious linear time invariant system (generally called a shaping filter) which is itself excited by white gaussian noise. Such a model is given by equation (10), where the subscript f, denotes filter and n, is a nonwhite, i.e., time-correlated, gaussian noise. The filter output is used to drive the system as show in Fig. 2.

$$\dot{x}_f = F_f x_f + \Gamma_f w \quad (10-a)$$

$$n = H_f x_f \quad (10-b)$$

The dimension of the state vector (1) is increased by including the disturbances as well as a description of the system dynamics behavior in appropriate rows of an enlarged F matrix, this is called state vector augmentation.

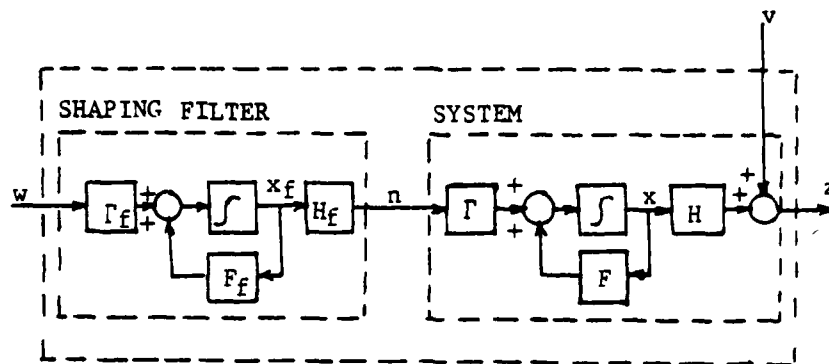

Figure 2
 Shaping filter generating driving noise.
 Conformation of the Augmented System.

The augmented state equation is given by

$$\begin{bmatrix} \dot{x} \\ \dot{x}_f \end{bmatrix} = \begin{bmatrix} F & \Gamma H_f \\ 0 & F_f \end{bmatrix} \begin{bmatrix} x \\ x_f \end{bmatrix} + \begin{bmatrix} 0 \\ \Gamma_f \end{bmatrix} w \quad (11)$$

The associated measurement equation given by equation (12)

$$z = \begin{bmatrix} H & 0 \end{bmatrix} \begin{bmatrix} x \\ x_f \end{bmatrix} + v \quad (12)$$

C. SENSITIVITY TO PARAMETER VARIATION

Observing the structure of the Kalman Filter illustrated in Figure 1; the filter contains an exact model of the system

dynamics. The filter gain matrix is calculated using the parameters of the exact model of the dynamics.

1. Incorrect Implementation of Dynamics

The analysis of how the error covariance behaves when the gain matrix is computed using wrong values of F matrix, i.e., varying parameters due to different flight conditions, is quite well explained in Reference [1]. Figure 3 shows the block diagram for the system model and the Kalman Filter, where the quantities K^* and F^* represent the gain matrix and the system dynamics implemented in the filter.

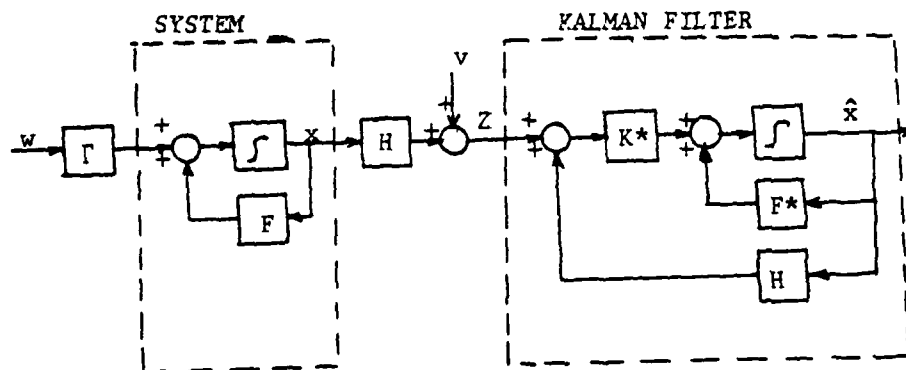

Figure 3

Block diagram of the System Model and Kalman Filter with incorrect implementation of dynamics.

The equation for the estimate is given by

$$\dot{\hat{x}} = F^* \hat{x} + K^*(z - H\hat{x}) \quad (13)$$

The error in the estimate given by (14)

$$\dot{\tilde{x}} = (F^* - K^*H)\tilde{x} + \Delta Fx - \Gamma w + K^*v \quad (14)$$

where

$$\Delta F = F^* - F$$

The differential equations for the states of a linear system driven by white gaussian noise given previously by equation (6) becomes now

$$\begin{bmatrix} \dot{\tilde{x}} \\ \dot{x} \end{bmatrix} = \begin{bmatrix} F^* - K^*H & \Delta F \\ 0 & F \end{bmatrix} \begin{bmatrix} \tilde{x} \\ x \end{bmatrix} + \begin{bmatrix} K^*v - \Gamma w \\ \Gamma w \end{bmatrix} \quad (15)$$

Letting x' be the augmented state vector, $x' = \begin{bmatrix} \tilde{x} \\ x \end{bmatrix}$, where the covariance matrix of x' is given by:

$$E(x'x'^T) = \begin{bmatrix} P & | & V^T \\ \hline V & | & U \end{bmatrix} \quad (16)$$

where

$$P \triangleq E(\tilde{x}\tilde{x}^T), \quad V \triangleq E(x\tilde{x}^T), \quad U \triangleq E(xx^T)$$

The quantity of interest is P , the covariance of x .

The error sensitivity equations are given by

$$\begin{aligned} \dot{P} = & (F^* - K^*H)P + P(F^* - K^*H)^T + \Delta FV \\ & + V^T\Delta F^T + \Gamma Q\Gamma^T + K^*RK^{*T} \end{aligned} \quad (17-a)$$

$$\dot{V} = FV + V(F^* - K^*H)^T + U\Delta F^T - \Gamma Q\Gamma^T \quad (17-b)$$

$$\dot{U} = FU + UF^T + \Gamma Q\Gamma^T \quad (17-c)$$

with initial conditions

$$P(0) = -V(0) = U(0) = E(x(0)x(0)^T)$$

when the actual system dynamics are faithfully reproduced in the filter, i.e., $F = F^*$, $\Delta F = 0$, the equation (17) reduces to the linear Lyapunov equation given by equation (8).

D. MODAL COORDINATES TRANSFORMATION

The representation of the system given by equation (1) is not unique. Considering an alternative linear transformation of the states given in references [3] and [4], let $x = T\xi$, where ξ represents the transformation of the states and T is the transformation matrix with the columns formed by the

eigenvectors of the system matrix F (for a complex eigenvalue, the first column is the real part and the second column is the imaginary part of the eigenvector). The similarity transformation of equation (1) is given by

$$\xi = A\xi + Bw \quad (18-a)$$

$$z = C\xi + v \quad (18-b)$$

where

$$A = T^{-1}FT, \quad B = T^{-1}\Gamma, \quad C = HT$$

A case of particular interest (canonical form) occurs when the resulting A matrix is diagonal (the eigenvalues of the F matrix form the diagonal). The design of the estimator in modal coordinates is analogous to using transfer functions in partial fraction form. The canonical form is more informative than the transfer function method, since observability and controllability can be obtained by inspection.

E. SOLUTION OF THE KALMAN FILTER WITH A PRESCRIBED DEGREE OF STABILITY

The Kalman Filter designed with constant gain (SKF) and used as an observer will diverge if there are undisturbed, neutrally stable (UNS) modes in the system model. In references [4] and [5] the authors presented the idea of

destabilization of the system model (1), the amount of destabilization can be varied until the resulting suboptimal observer has a specified degree of stability. The method presented in Ref. [4] refers only to destabilizing the UNS modes in the system model, that method is called "modal destabilization" (MDS). The gains of the filter are constrained so that

$$\text{Re}(S_i) \geq -\sigma, \quad i = 1, 2, \dots, n \quad (19)$$

where $\text{Re}(S_i)$ indicates "real part of (S_i) ," S_1, \dots, S_n are the eigenvalues of the filter, i.e., the roots of equation (9) and σ is a specified positive number.

The original system is destabilized in accordance with equation (20), where F' is the resultant destabilized matrix, E the destabilization matrix (diagonal) and T is the modal transformation matrix (eigenvector matrix). The matrix F' is used in order to calculate the modified gains of the filter (suboptimal gains).

$$F' = F + TET^{-1} \quad (20)$$

This method avoids the divergence of the steady-state Kalman Filter with a slight decrease in estimation accuracy.

III. DYNAMIC AND MEASUREMENT SYSTEM MODELS

A. REFERENCE AXIS SYSTEM

The Reference Axis System in a missile is centered on the c.g. and fixed on the body as follows:

X axis, called the roll axis, forwards, along the axis of symmetry.

Y axis, called the pitch axis, outwards and to the right if viewing the missile from behind.

Z axis, called the yaw axis, downwards in the plane of symmetry to form a right-handed orthogonal system with the other two.

The symbols from Appendix A define the forces and moments acting on the missile, the linear and angular velocities, and the moments of inertia; those quantities are shown in Figure 4.

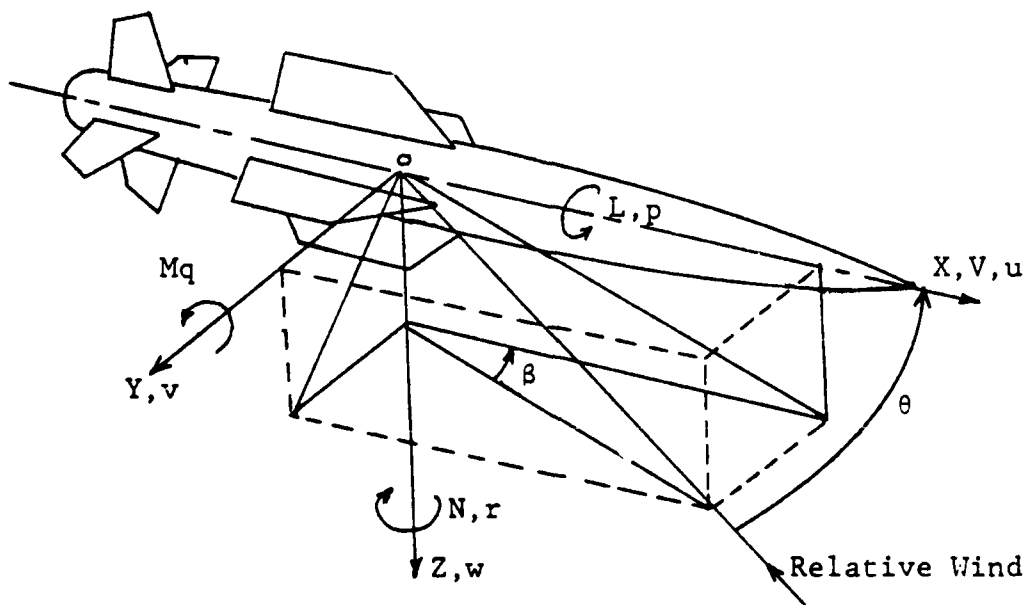

Figure 4
Reference Axis System

B. MISSILE EQUATIONS OF MOTION

The equations of motion used in the present study in order to represent the missile dynamics are quite well defined in Reference [7]. A linear dynamical model of the missile based on the rigid body approximation is appropriate.

1. Longitudinal Motion

The longitudinal motions of a missile are modeled by a fifth-order system given by equation (21), where the state variables are u , velocity along the X axis; w , velocity along the Z axis; q , pitch rate, θ , pitch angle and h , altitude.

$$\begin{bmatrix} \dot{u} \\ \dot{w} \\ \dot{q} \\ \dot{\theta} \\ \dot{h} \end{bmatrix} = \begin{bmatrix} X_w & X_w & 0 & -g & 0 \\ Z_w & Z_w & V & 0 & 0 \\ M_u + M\dot{w}Z_u & M_w + M\dot{w}Z_w & Mq + M_wV & 0 & 0 \\ 0 & 0 & 1 & 0 & 0 \\ 0 & -1 & 0 & V & 0 \end{bmatrix} \begin{bmatrix} u \\ w \\ q \\ \theta \\ h \end{bmatrix} \quad (21)$$

2. Lateral Motion

The lateral motions of a missile are modeled by a fifth-order system given by equation (22), where the state variables defined are; β sideslip angle; r yaw rate; p roll rate; ϕ roll angle; ψ heading angle.

$$\begin{bmatrix} \dot{\beta} \\ \dot{r} \\ \dot{p} \\ \dot{\phi} \\ \dot{\psi} \end{bmatrix} = \begin{bmatrix} Yv & -1 & 0 & g/V & 0 \\ N_{\beta}^1 & N_r^1 & N_p^1 & 0 & 0 \\ L_{\beta}^1 & L_r^1 & L_p^1 & 0 & 0 \\ 0 & 0 & 1 & 0 & 0 \\ 0 & 1 & 0 & 0 & 0 \end{bmatrix} \begin{bmatrix} \beta \\ r \\ p \\ \phi \\ \psi \end{bmatrix} \quad (22)$$

C. MODEL

The aerodynamic data used in the present study is given in Appendix B [Ref 9]. Essentially the models and noise dynamics are those of reference [4].

1. Longitudinal Motion Estimation

The main disturbance inputs are the two wind velocities u_g and w_g . Under the particular flight conditions, the turbulence represented by the fluctuating parts of u_g and w_g are color noise. They are modeled by first-order shaping filters with white gaussian noise inputs as given in equation (10). The resultant linear model is given by equation (23) [Ref 8].

$$\begin{bmatrix} \dot{u}_g \\ \dot{w}_g \end{bmatrix} = \begin{bmatrix} -0.413 & 0 \\ 0 & -0.853 \end{bmatrix} \begin{bmatrix} u_g \\ w_g \end{bmatrix} + \begin{bmatrix} 0.413 & 0 \\ 0 & 0.853 \end{bmatrix} \begin{bmatrix} u_u \\ u_w \end{bmatrix} \quad (23)$$

The numerical data for the longitudinal dimensional derivatives was used in equation (21), the resultant model is

given by equation (24), that corresponds to the state vector augmentation given by equation (11). Units are scaled with u , w , u_g and w_g in units of 10 ft/s, q in units of 0.01 rad/s.

$$\begin{bmatrix} \dot{u} \\ \dot{w} \\ \dot{q} \\ \dot{\theta} \\ \dot{h} \\ \dot{u}_g \\ \dot{w}_g \end{bmatrix} = \begin{bmatrix} -0.015 & 0.004 & 0 & -0.0322 & 0 & -0.015 & 0.004 \\ -0.074 & -0.806 & 0.824 & 0 & 0 & -0.074 & -0.806 \\ -0.749 & -10.7 & -1.344 & 0 & 0 & 0.749 & -10.7 \\ 0 & 0 & 1 & 0 & 0 & 0 & 0 \\ 0 & -0.1 & 0 & 0.0824 & 0 & 0 & 0 \\ 0 & 0 & 0 & 0 & 0 & -0.413 & 0 \\ 0 & 0 & 0 & 0 & 0 & 0 & -0.853 \end{bmatrix} \begin{bmatrix} u \\ w \\ q \\ \theta \\ h \\ u_g \\ w_g \end{bmatrix} + \begin{bmatrix} 0 & 0 \\ 0 & 0 \\ 0 & 0 \\ 0 & 0 \\ 0 & 0 \\ 0.413 & 0 \\ 0 & 0.853 \end{bmatrix} \begin{bmatrix} \mu_u \\ \mu_w \end{bmatrix} \quad (24)$$

θ in units of 0.01 rad., and h in units of 100 ft.

The measurement model given by equation (25) assumes a rate gyro in order to measure z_q and a barometric altimeter in order to measure z_h .

$$\begin{bmatrix} z_q \\ z_h \end{bmatrix} = \begin{bmatrix} 0 & 0 & 1 & 0 & 0 & 0 & 0 \\ 0 & 0 & 0 & 0 & 1 & 0 & 0 \end{bmatrix} \begin{bmatrix} u \\ w \\ q \\ \theta \\ h \\ u_g \\ w_g \end{bmatrix} + \begin{bmatrix} 1 & 0 \\ 0 & 1 \end{bmatrix} \begin{bmatrix} v_q \\ v_h \end{bmatrix} \quad (25)$$

2. Lateral Motion Estimation

The main disturbance input is lateral wind v_g . The turbulence represented by the fluctuating part of v_g is color noise, it is modeled as a first-order shaping filter with white gaussian noise input as given in equation (10). The resulting shaping filter is as given by equation (26) and taken from Reference [4].

$$\dot{\beta}_g = -0.853\beta_g + 0.853\mu \quad (26)$$

where

$$\beta_g = v_g/v$$

The numerical data for the lateral dimensional derivatives was used in equation (22) to obtain the equation (27). This corresponds to the state vector augmentation given by equation (11).

$$\begin{bmatrix} \dot{\beta} \\ \dot{r} \\ \dot{p} \\ \dot{\phi} \\ \dot{\downarrow} \\ \dot{\beta}_g \end{bmatrix} = \begin{bmatrix} -0.0868 & -1 & 0 & 0.03907 & 0 & -0.0868 \\ 2.14 & -0.228 & -0.0204 & 0 & 0 & 2.14 \\ -4.41 & 0.334 & -1.181 & 0 & 0 & -4.41 \\ 0 & 0 & 1 & 0 & 0 & 0 \\ 0 & 1 & 0 & 0 & 0 & 0 \\ 0 & 0 & 0 & 0 & 0 & -0.853 \end{bmatrix} \begin{bmatrix} \beta \\ r \\ p \\ \phi \\ \downarrow \\ \beta_g \end{bmatrix} + \begin{bmatrix} 0 \\ 0 \\ 0 \\ 0 \\ 0 \\ 0.853 \end{bmatrix} \mu \quad (27)$$

The measurement model given by equation (28), represents the situation where the measurement z_p is taking with a roll-rate gyro and the measurement z_ψ using a magnetic compass.

$$\begin{bmatrix} z_p \\ z_\psi \end{bmatrix} = \begin{bmatrix} 0 & 0 & 1 & 0 & 0 & 0 \\ 0 & 0 & 0 & 0 & 1 & 0 \end{bmatrix} \begin{bmatrix} \beta \\ r \\ p \\ \phi \\ \psi \\ \beta_g \end{bmatrix} + \begin{bmatrix} 1 & 0 \\ 0 & 1 \end{bmatrix} \begin{bmatrix} v_p \\ v_\psi \end{bmatrix} \quad (28)$$

IV. ANALYSIS

A. THE SIMULATION

A computer program was developed in order to solve the sensitivity equations given by equation (17). Basically, the program was used to handle a set of 105 linear differential equations in the longitudinal case and 78 in the lateral. The principle program output is the time history of the P matrix and the square root of its diagonal elements (the rms estimate errors).

The Kalman Filter computer program was the primary tool used in computing the gains. The program was developed at the Massachusetts Institute of Technology [Ref. 10] and adapted for use at the Naval Postgraduate School. A second computer program composed at Stanford University, OPTSYS 4 Computer Program [Ref. 11], which utilizes several options of the Kalman Filter, was also implemented in this analysis. In particular, the suboptimal filter using the modal destabilization (MDS) design option was required for the lateral case.

B. THE RESULTS

As the problem is described, the results are presented in two parts, the longitudinal and the lateral case.

Initially both models given by equations (24) and (27) were modified in order to include another state in each of them, the perturbed position. The resultant observers were

tested, but in both cases they were unstable.

1. Longitudinal Motion Estimation Analysis

A steady-state Kalman Filter was designed [Ref. 4] and used as a constant gain state estimator (equation (3)).

The first step in this analysis was to reproduce the results for the case of exact implementation of dynamics in the calculation of the Kalman gain matrix. That analysis was done using the M.I.T. Kalman Filter Computer Program [Ref. 10]. The results are shown below:

Filter gain matrix K.

0.059	0.060
0.264	-0.161
3.517	0.040
0.001	-0.080
0.013	0.136
-0.011	0.035
-1.288	0.128

Filter Eigenvalues

-0.310 + j0.411
-0.429
-0.178
-0.261
-0.063 + j0.0743

rms estimate errors

\bar{u} = 2.090 ft/s	$\bar{\theta}$ = 0.317 deg
\bar{w} = 5.102 ft/s	\bar{h} = 8.245 ft
\bar{q} = 0.416 deg/s	\bar{u}_g = 4.776 ft/s
	\bar{w}_g = 5.701 ft/s

These results are essentially identical to those of Ref. [4].

The next objective was to consider the incorrect implementation of dynamics in the Kalman Filter, in order to study the sensitivity of rms estimate errors to inaccuracies in the stability derivatives. The numerical variation of the parameters were considered individually in order to establish the F^* matrix to be used in equation (17) and also for finding the filter gain matrix K^* to be implemented in the same equation. For each variation of the parameter under observation it was necessary to run the M.I.T. Computer Program [Ref. 10] in order to find the matrix of gains K^* and then to run the sensitivity covariance program in order to study the propagation of the estimate errors.

The results are shown in Tables 1-8 and Figures 5-40. In the Tables, the true value of each parameter is marked with an asterisk. The description of the results are:

Xu. The dimensional variation of X force with forward speed (u) has a nominal value of -0.015. This quantity was changed in a range of $\pm 20\%$. The behavior of the rms estimate errors are presented in Table 1. From that it can be seen that any numerical variation of Xu derivative does not cause significant changes in the nominal values of the rms estimate errors of the states, \bar{w} , \bar{q} , $\bar{\theta}$, \bar{u}_g and \bar{w}_g . For the states \bar{u} and \bar{h} the results are shown in Figures 5-6 respectively, with some effect, but not significant for positive variation of Xu.

Xw. The dimensional variation of X force with downward speed (w) has a nominal value of 0.004. As before, the numerical variation was performed in a range of $\pm 20\%$. The behavior of the rms estimate errors were tabulated in Table 2. Checking the results there is no variation in the nominal values of rms estimate errors of the states, \bar{w} , \bar{q} , $\bar{\theta}$, \bar{u}_g and \bar{w}_g , for any of the changes made in Xw derivative. The variations in the estimate errors for \bar{u} and \bar{h} are indicated in Figures 7 and 8 respectively. Increasing the value of Xw the \bar{u} error decreases but \bar{h} increases, while taking smaller values of the parameter, the effect is contrary. Those changes in the rms errors are considered not important.

Zu. The dimensional variation of Z force caused by a change in forward speed (u) has a nominal value of -0.074. The effects of changing its design value was observed in a range of 20% and its result condensed in Table 3 as well as in Figures 9-14. All the rms errors show some degree of sensitivity except \bar{q} . The most important changes occur in \bar{u} , $\bar{\theta}$, and \bar{h} errors and the large variation in \bar{u} can begin to be important in terms of accuracy in radial position.

Zw. The dimensional variation of Z force with downward speed (w) has a nominal value of -0.806. The results for this case are presented in Table 4 and Figures 15-20. Again, the variation in the value of Zw was made in a range of $\pm 20\%$. All the rms estimate errors show a large degree of

sensitivity and it can be considered that any numerical variation of Z_w beyond $\pm 2\%$ is critical and unacceptable.

Mu. The dimensional variation of M moment caused by a change in forward speed (u) has a nominal value of -0.000786 . The value of M_u was changed in a range of 20% and the results are given in Table 5 as well as Figures 21-26. Any variation in M_u quantity does not cause important changes in the value of the rms estimate errors of the states, \bar{a} , \bar{u}_g and \bar{w}_g . For the states \bar{u} , \bar{w} , $\bar{\theta}$, and \bar{h} , the variation in the errors can be considered with some significant effect for large deviations of M_u value, i.e., more than $\pm 10\%$.

Mw. The dimensional variation of M moment with speed (w) has a nominal value of -0.0111 . Its numerical variation was taken in a range of $\pm 10\%$. From Table 6 and Figures 27-32, it can be seen that any alteration in the true value of M_w is reflected with a strong effect on all the rms estimate errors. This derivative can be considered the most critical in the longitudinal motion estimation case.

Mq. The dimensional variation of pitching moment with pitch rate (q) has a nominal value of -0.924 . The results are given in Table 7 and Figures 33 and 34 for a range of $\pm 20\%$ in the numerical variation of M_q . The sensitivity of the rms estimate errors due to changes in this parameter is minimum for all the states.

$\dot{M}\dot{w}$. The dimensional variation of pitching moment with rate of change of downward speed (\dot{w}) has a nominal value of -0.00051. Table 8 and Figures 35-40 presents the information about the changes of the rms estimate errors in a range of $\pm 20\%$ in the variation of $M\dot{w}$ derivative. All the errors show some degree of sensitivity and with more than $\pm 2\%$ in the alteration of the $M\dot{w}$ value, the variation in the errors begins to be significant.

2. Lateral Motion Estimation Analysis

The dynamic system (equation (27)) and measurement models (equation (28)) were transformed into modal coordinates in accordance with equation (18). This was done using the OPTSYS 4 Computer Program [Ref. 11]; the results are given below:

$$\begin{bmatrix} \dot{\xi}_{D1} \\ \dot{\xi}_{D2} \\ \dot{\xi}_R \\ \dot{\xi}_S \\ \dot{\xi}_H \\ \dot{\xi}_{vg} \end{bmatrix} = \begin{bmatrix} -0.119 & 1.490 & 0 & 0 & 0 & 0 \\ -1.490 & -0.119 & 0 & 0 & 0 & 0 \\ 0 & 0 & -1.254 & 0 & 0 & 0 \\ 0 & 0 & 0 & -0.0041 & 0 & 0 \\ 0 & 0 & 0 & 0 & 0 & 0 \\ 0 & 0 & 0 & 0 & 0 & -0.853 \end{bmatrix} \begin{bmatrix} \xi_{D1} \\ \xi_{D2} \\ \xi_R \\ \xi_S \\ \xi_H \\ \xi_{vg} \end{bmatrix} + \begin{bmatrix} -1.702 \\ -0.610 \\ -5.106 \\ -0.004 \\ 0 \\ 3.788 \end{bmatrix} \quad [\mu]$$

(29)

$$\begin{bmatrix} z_p \\ z_\psi \end{bmatrix} = \begin{bmatrix} 1 & 0 & -0.782 & 0 & 1 & -0.605 \\ 0.276 & 0.295 & -0.008 & 0.995 & 1 & 0.162 \end{bmatrix} \begin{bmatrix} \xi_{D1} \\ \xi_{D2} \\ \xi_R \\ \xi_S \\ \xi_H \\ \xi_{vg} \end{bmatrix} + \begin{bmatrix} 1 & 0 & v_p \\ 0 & 1 & v_\psi \end{bmatrix} \quad (30)$$

These results are identical to those given in Ref. [4]. In the same reference the author gives a complete analysis of controllability and observability using the results given in equations (29) and (30). From these can be seen that the spiral mode ξ_S has its eigenvalue close to the origin and it is almost undisturbed by the process noise; also it is unobservable with the measurement z_p . Using a steady-state Kalman Filter as an observer fail to estimate the heading mode ξ_H and its estimation of the spiral mode ξ_S is too slow. The next objective was to take the SKF and to consider the situation of parameter variations in the dynamic implemented in the filter. With the true values of the F matrix implemented in the filter the results are shown below:

<u>Filter Gain Matrix K</u>	
0.051	-0.967
-1.536	0.411
2.695	-0.004
0.386	-0.789
-0.005	0.906
-1.713	0.655

Filter Eigenvalues

-2.350 + j2.594
-0.624 + j0.492
-0.00125
0.0

rms Estimate Errors

$\bar{v}_B = 3.329$ ft/s
 $\bar{r} = 0.244$ deg/s
 $\bar{p} = 0.377$ deg/s
 $\bar{\phi} = 0.222$ deg
 $\bar{\psi} = 0.214$ deg
 $\bar{v}_{Bg} = 5.506$ ft/s

These results are essentially identical to those from Ref. [4]. The filter was found to be stable but with a narrow margin of stability. Any attempt to change parameters resulted in a failure of the estimator due to divergence with the most minimum variation (i.e., $\pm 1\%$) of any of the parameters. This result complements the analysis given previously [Ref. 4] and it shows definitely that it is impossible to use the SKF as an estimator for the lateral motion with the actual configuration of the model given by equations (27) and (28).

The alternative solution was to design a suboptimal observer (MDS) with the constrain (19) as given in Ref. [4], $\sigma = 0.029$ and using equation (20) in the MDS option the computer program OPTSYS 4 [Ref. 11]. The results are:

Filter Gain Matrix K

-0.073	-0.871
-1.560	0.430
2.731	-0.033
0.339	-0.753
-0.033	0.928
-1.622	0.585

Filter Eigenvalues

-2.350 + j2.589
-0.624 + j0.492
-0.0291 + j0.005

rms Estimate Errors

$\bar{v}_\beta = 3.799$ ft/s
 $\bar{r} = 0.245$ deg/s
 $\bar{p} = 0.379$ deg/s
 $\bar{\phi} = 0.226$ deg
 $\bar{\psi} = 0.216$ deg
 $\bar{v}_{\beta g} = 5.712$ ft/s

These results are essentially identical to those from Ref. [4].

The sensitivity of the lateral rms estimate errors due to inaccuracies in the stability derivatives was studied using the suboptimal filter (MDS) design and following the same procedure explained before for the longitudinal case. The results are shown in Tables 9-15 and Figures 41-76. The results are described in detail as follows:

Y_v. The dimensional variation of Y force with side velocity (v) has a nominal value of -.0868. This value was changed in a range of $\pm 20\%$ and the results appear in Table 9 and Figures 41-44. \bar{r} , \bar{p} , $\bar{\psi}$, and $V\bar{\beta}g$ show almost no sensitivity to the variation in Y_v parameter, $V\bar{\beta}$ changes but it can be considered of secondary importance. The most sensitivity change occurs in $\bar{\phi}$ and it begins to be important for a variation of $\pm 5\%$ in Y_v value.

N'_β. The dimensional variation of yawing moment about Z axis with sideslip angle (β) has a nominal value of 2.14. Table 10 and Figures 45-50 give the results for a variation of N'_β derivative in a range of $\pm 10\%$. All the rms estimate errors except $\bar{\psi}$ present strong sensitivity, especially $V\bar{\beta}$ and $\bar{\phi}$. With a variation of more than $\pm 1\%$ the estimation of these errors begin to show large values and the filter takes a long time to reach the steady state value (more than 150 s). For that reason, any variation in the true value of N'_β with the purpose of implementation in a Kalman Filter as an estimator must be considered unacceptable.

N'_r. The dimensional variation of yawing moment about Z axis with yaw rate (r) has a nominal value of -0.228. In a range of $\pm 20\%$ the variation of N'_r value was performed and the results tabulated in Table 11 as well as the important variations registered in Figures 51-54. The effects on sensitivity of all the rms estimate errors are secondary and

there is no important alteration in their values due to large variations in the N_r^i parameter.

N_p . The dimensional variation of yawing moment about Z' axis with roll rate (p) has a nominal value of -0.0204. This number was changed in a range of $\pm 20\%$ and the results observed are given in Table 12 and Figures 55-60. \bar{r} , \bar{p} , $\bar{\psi}$, and $\sqrt{\bar{\beta}}g$ rms errors do not present any important variation. The sensitivity in rms estimate error is observed in $\sqrt{\bar{\beta}}$ and $\bar{\phi}$, in particular. For the last one, the change is too large for a variation of 5% in the value of the parameter.

L_β . The dimensional variation of rolling moment about X axis with sideslip angle (β) has a nominal value of -4.41. Its variation was given just in a margin of $\pm 10\%$ because with larger changes the estimator starts to diverge. The results obtained are given in Table 13 and Figures 60-66. All the rms estimate errors show some degree of sensitivity due to the variation in L_β^i parameter and with 1% of change some of the errors like $Vg^{\bar{}}$ and $\bar{\phi}$ present very large variations. For that reason this derivative must be considered critical in the implementation of the Kalman Filter as an estimator.

L_r^i . The dimensional variation of rolling moment about X axis with yaw rate (r) has a nominal value of -0.334. The results presented in Table 14 and Figures 67-72 are the product of the observation for the variation of the parameter L_r^i in a range of $\pm 10\%$ and it can be considered as the most

important stability derivative for the lateral model, because the dynamics implemented in the filter does not allow any variation of its true value, otherwise, the estimation of the errors becomes to be too large and probably the filter can diverge. In other words, the sensitivity of the estimator to any variation in L'_r value is extremely critical.

$L_{\dot{\phi}}$. The dimensional variation of rolling moment about X axis with roll rate has a nominal value of -1.204. The behavior of the rms estimate errors were observed taking a variation of $\pm 10\%$ of the $L_{\dot{\phi}}$ parameter and they are given in Table 15 and Figures 73-76. \bar{V}_{β} and \bar{r} are the variables that present some degree of sensitivity in the increment of their rms estimate errors, respectively, and they begin to be important with a variation of more than $\pm 5\%$ of the $L_{\dot{\phi}}$ true value.

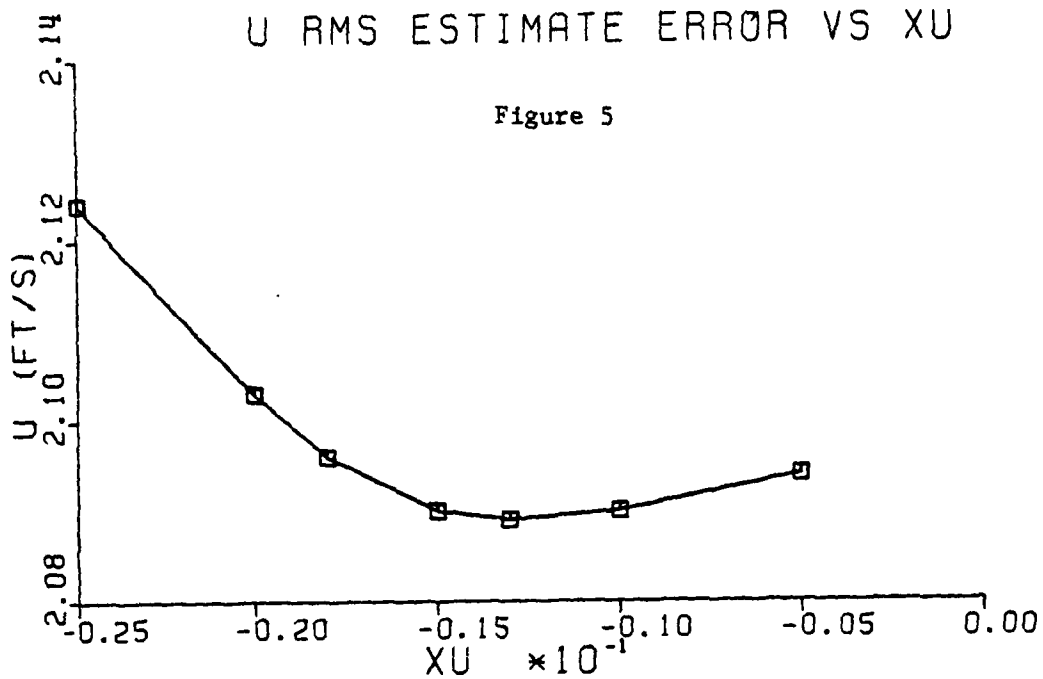

Figures 5 & 6. Sensitivity of \bar{u} and \bar{h} rms estimate errors vs variation in X_u stability derivative

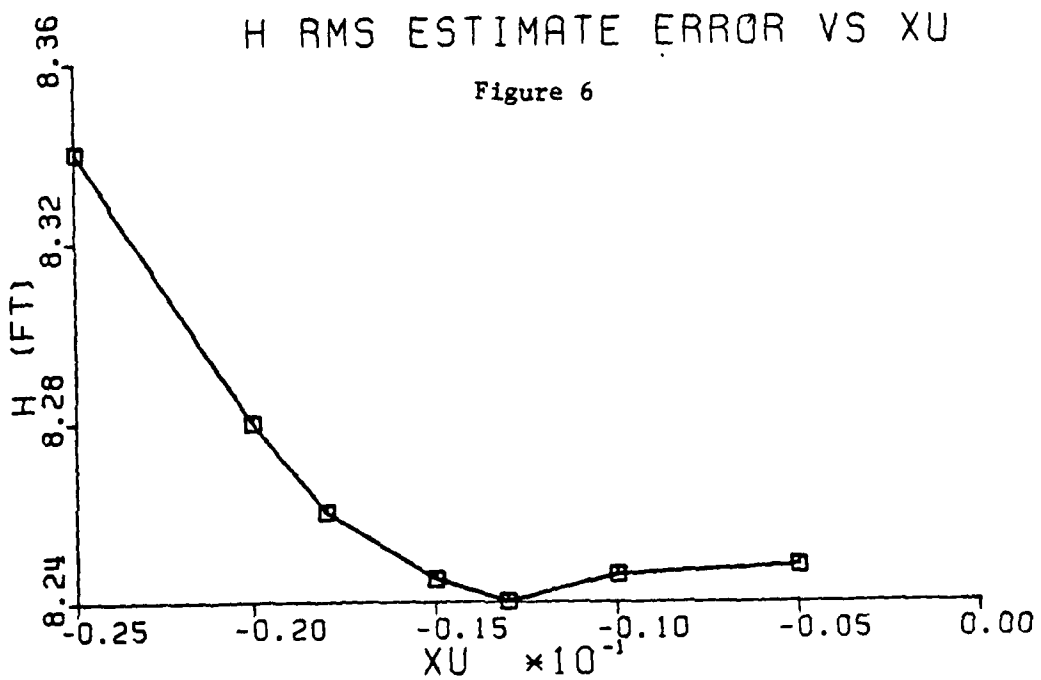

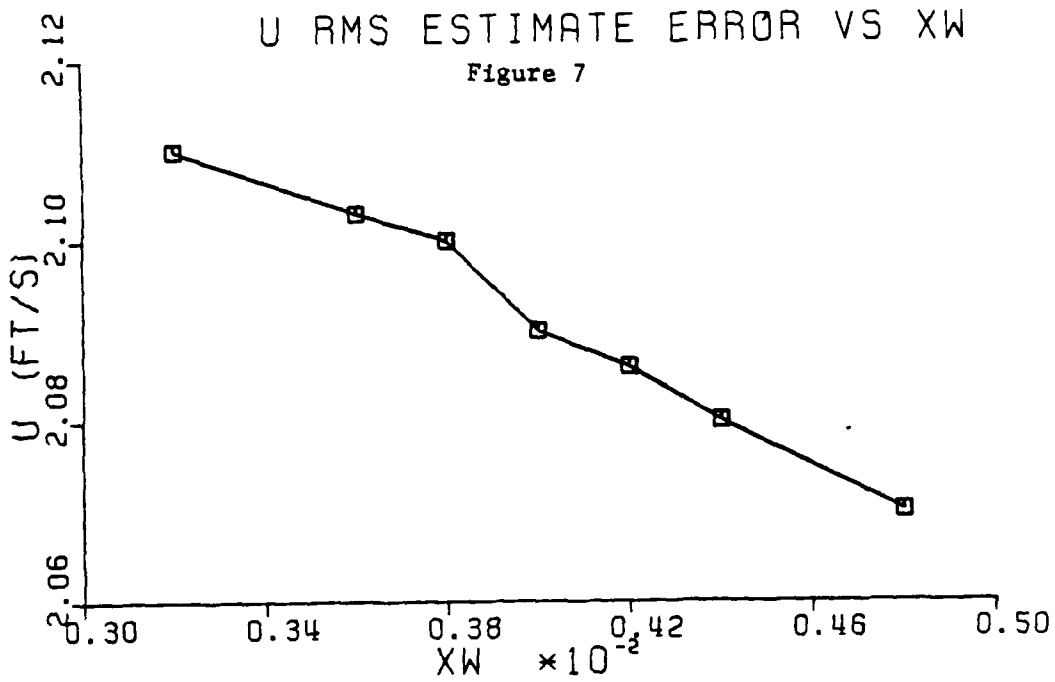

Figures 7 & 8. Sensitivity of \bar{u} and \bar{h} rms estimate errors vs variation in X_w stability derivative.

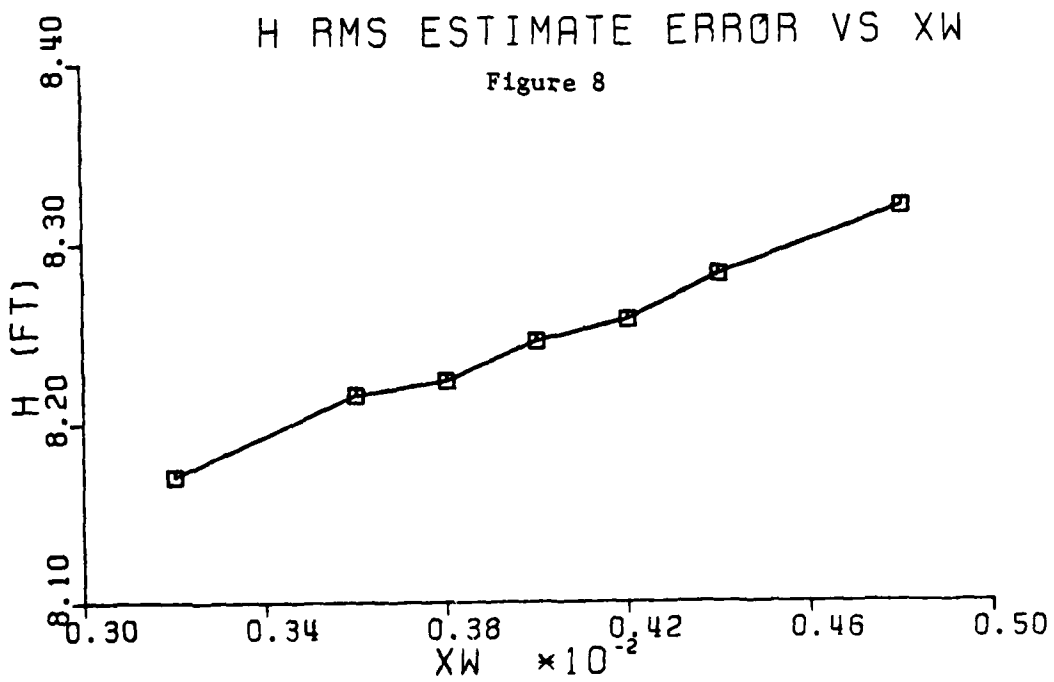

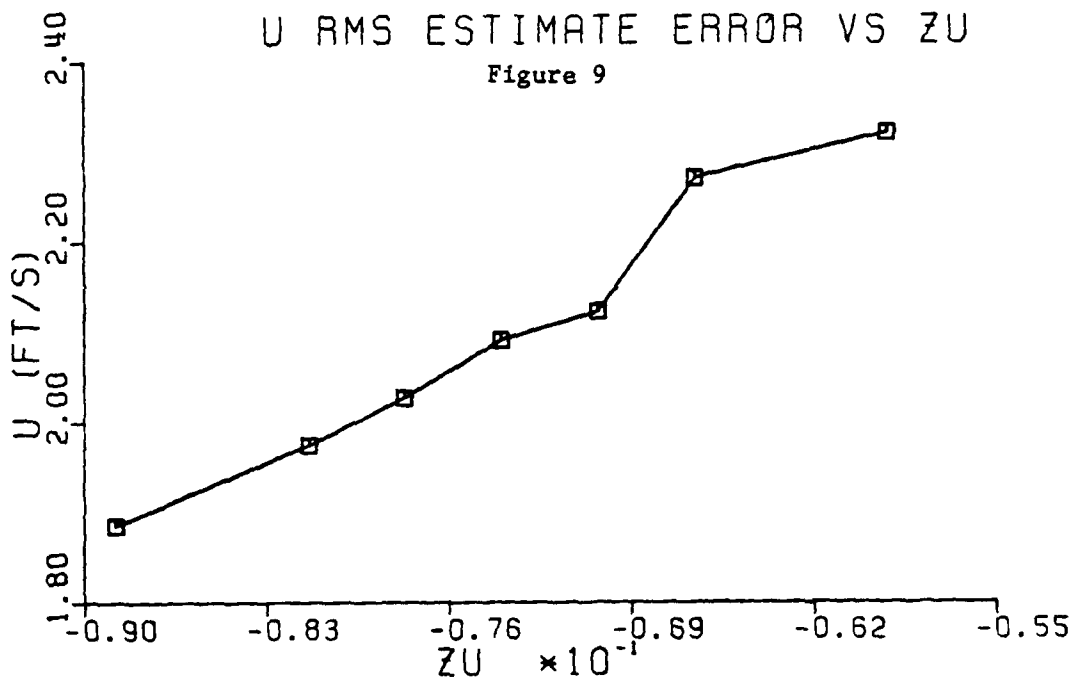

Figures 9 & 10. Sensitivity of \bar{u} and \bar{w} rms estimate errors vs variation in Zu stability derivative.

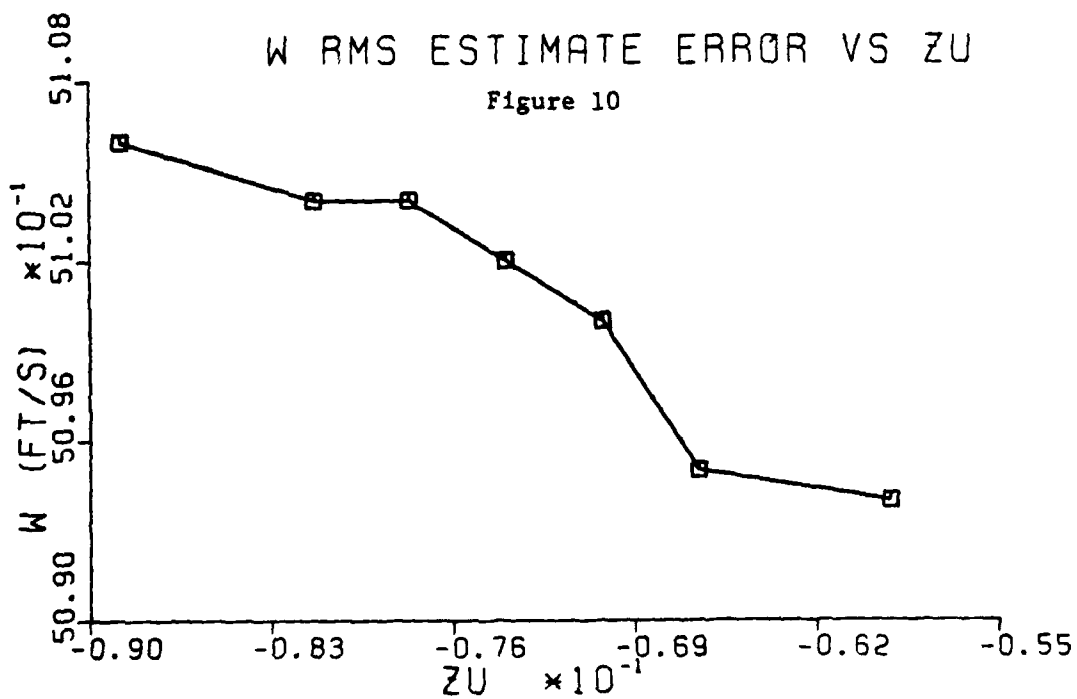

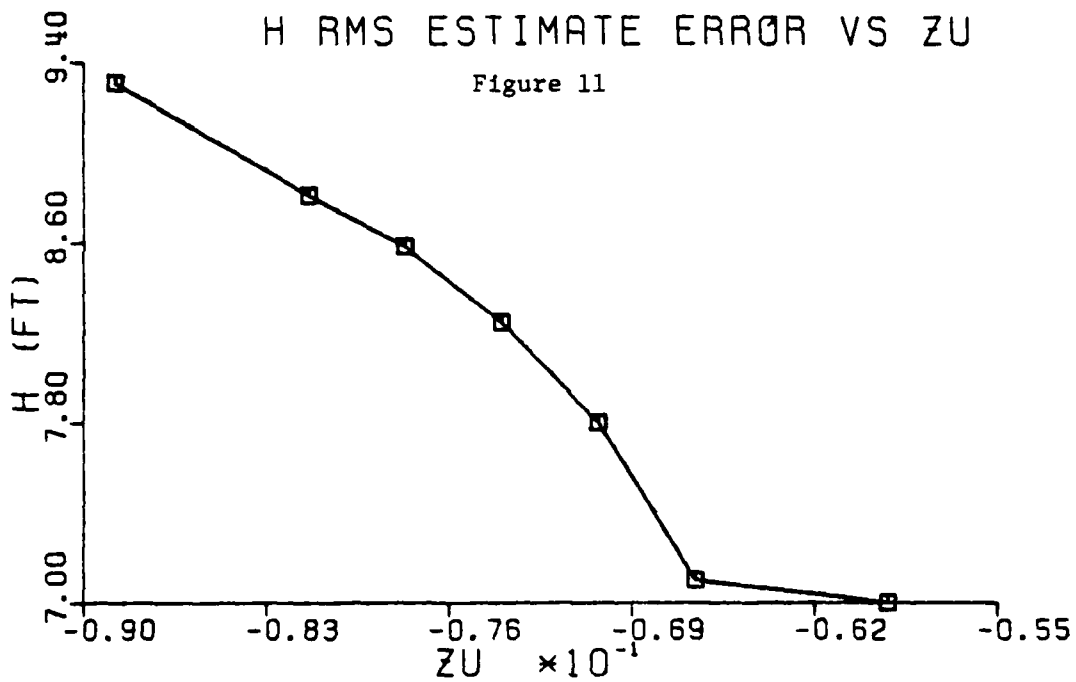

Figures 11 & 12. Sensitivity of \bar{h} and $\bar{\theta}$ rms estimate errors vs variation in Zu stability derivative.

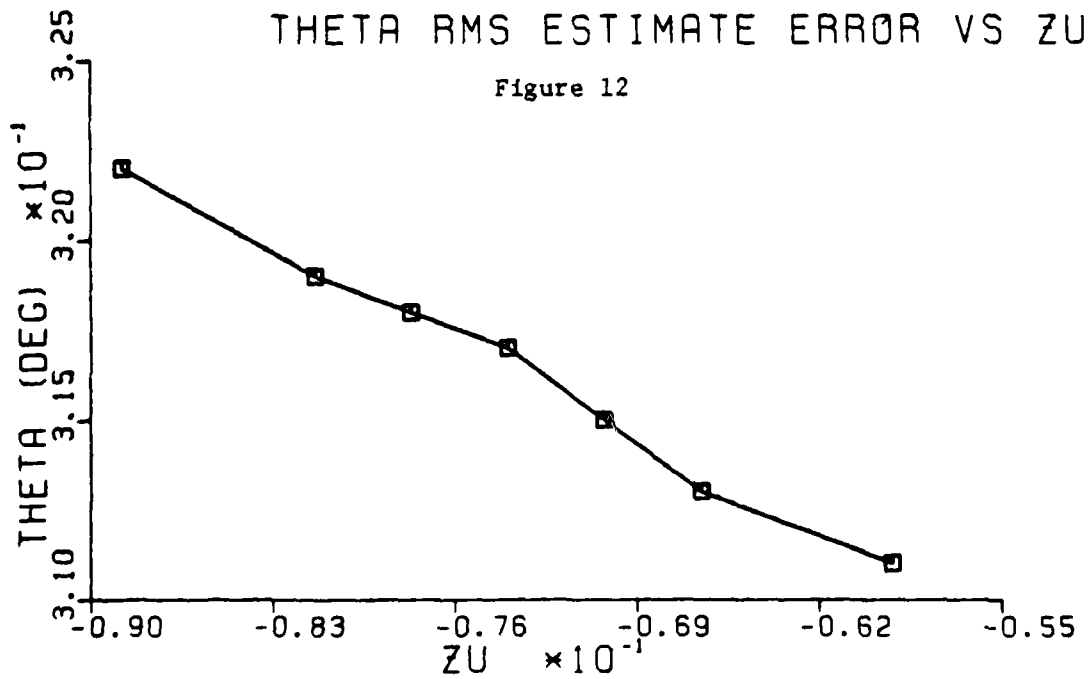

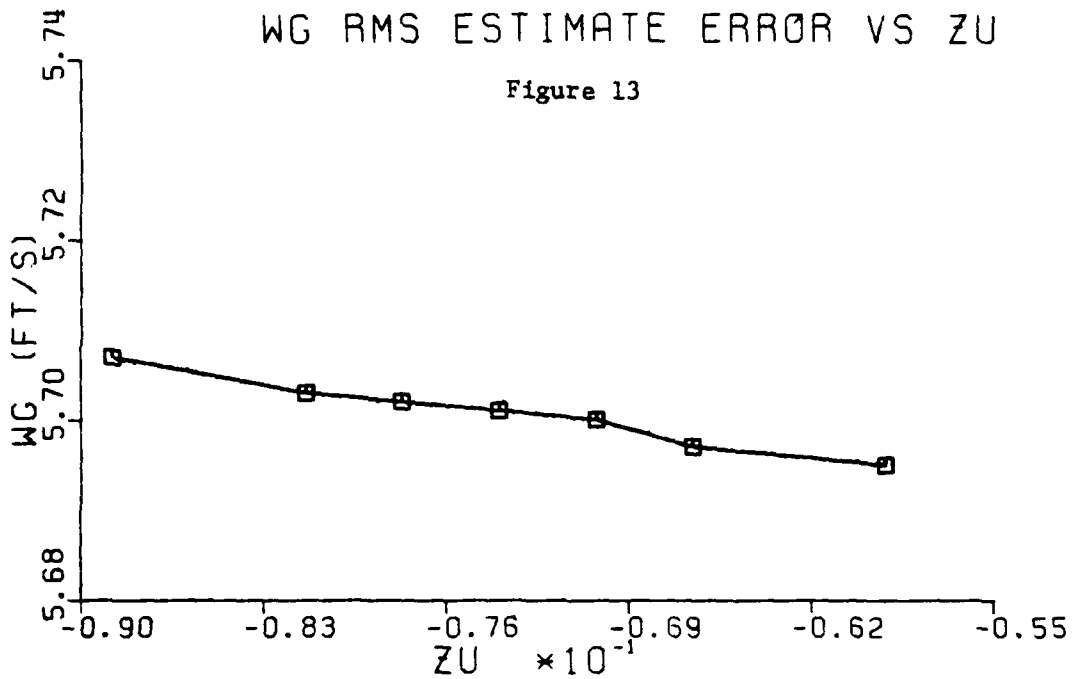

Figures 13 & 14. Sensitivity of \bar{w}_g and \bar{u}_g rms estimate errors vs variation of Zu stability derivative.

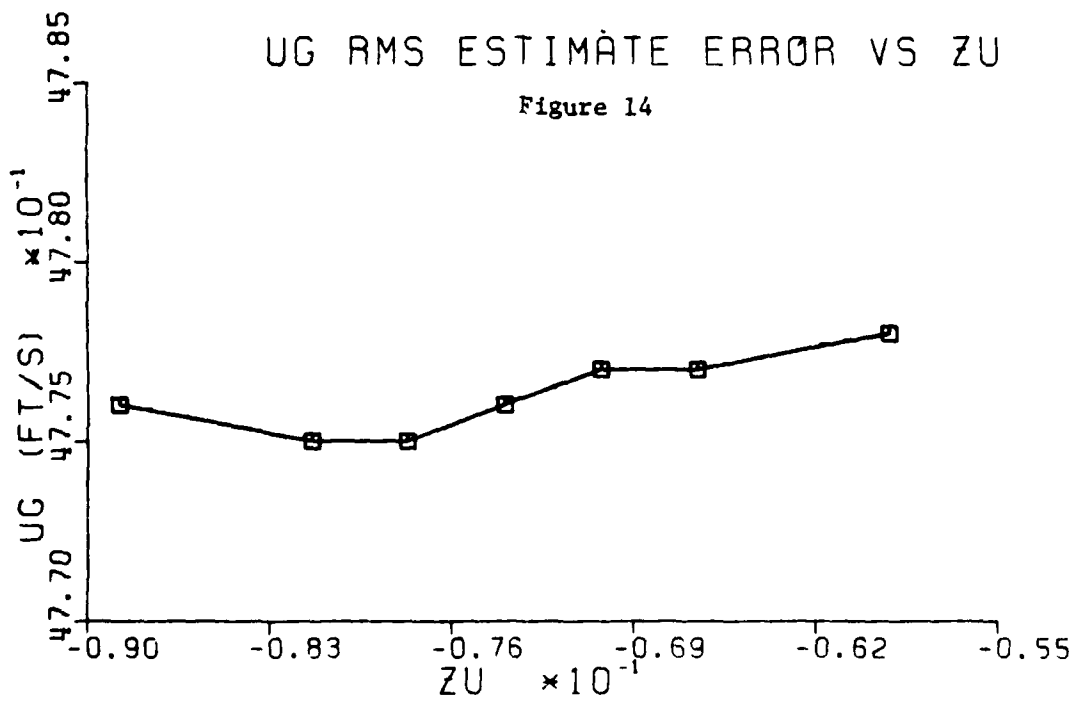

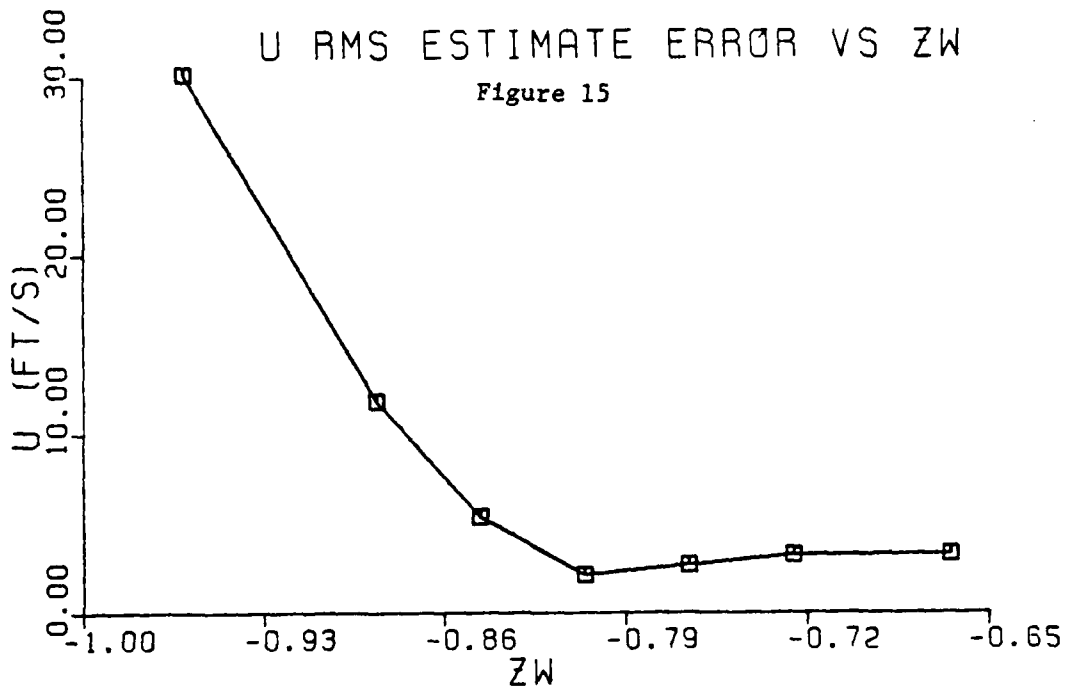

Figures 15 & 16. Sensitivity of \bar{u} and \bar{w} rms estimate errors vs variation in ZW stability derivative.

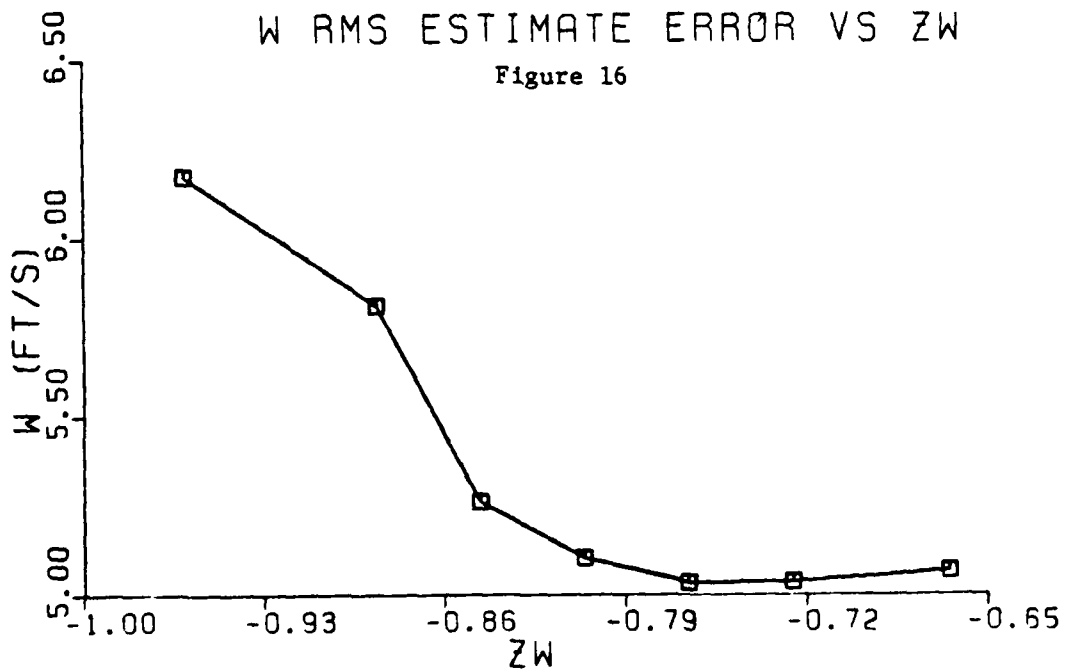

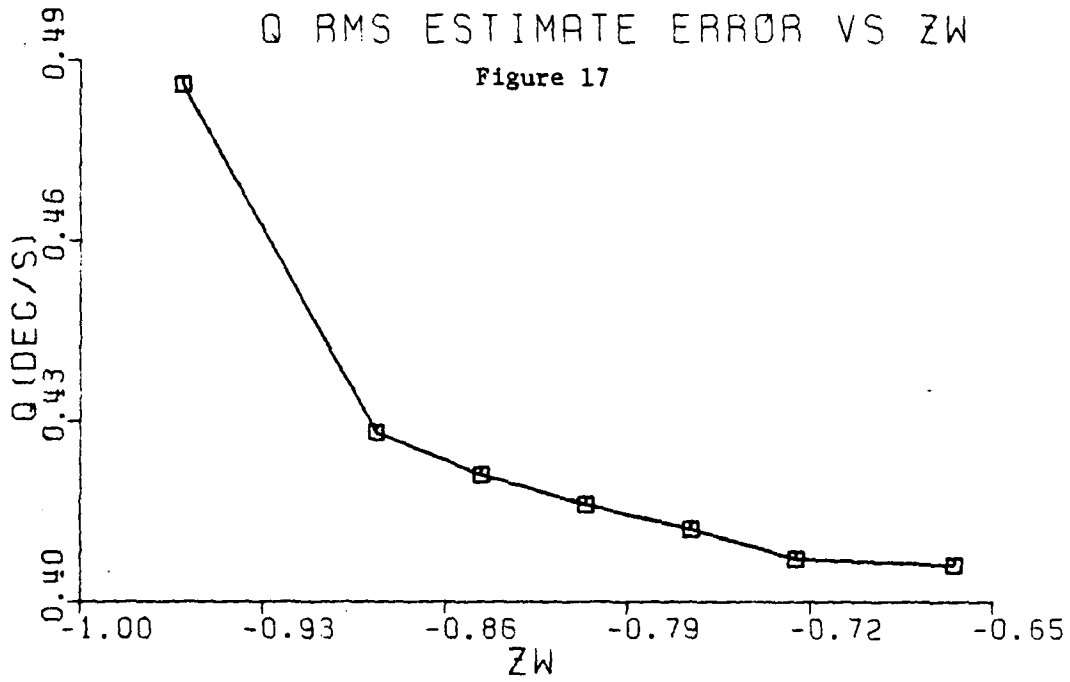

Figures 17 & 18. Sensitivity of \bar{q} and $\bar{\theta}$ rms estimate errors vs variation in ZW stability derivative.

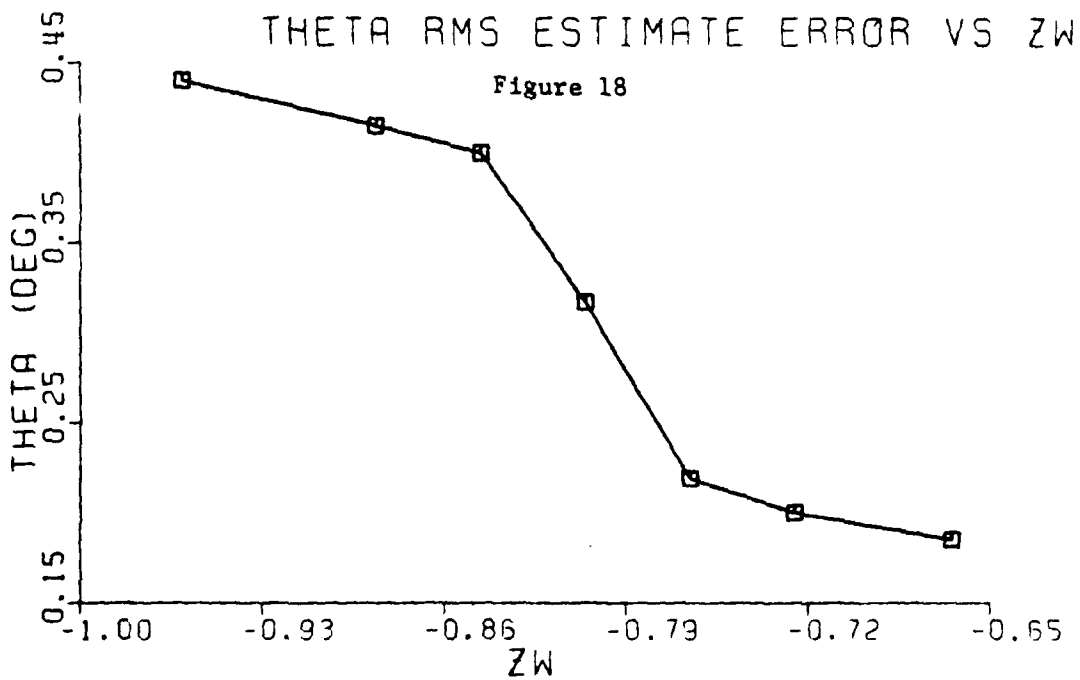

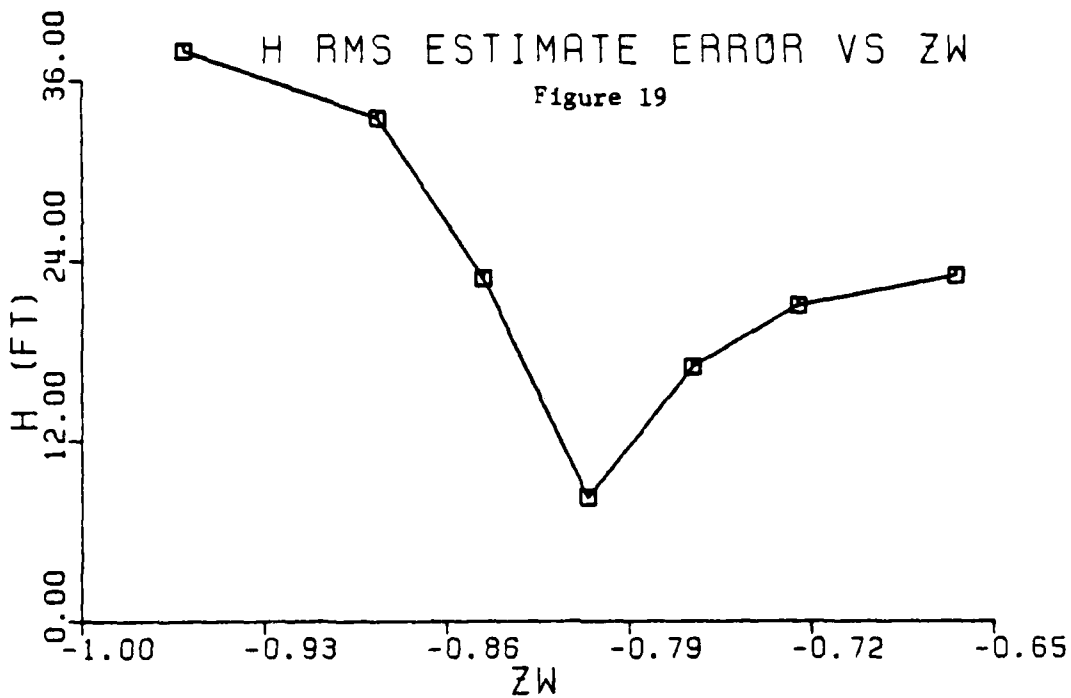

Figures 19 & 20. Sensitivity of \bar{h} and \bar{u}_g rms estimate errors vs variation in Z_w stability derivative.

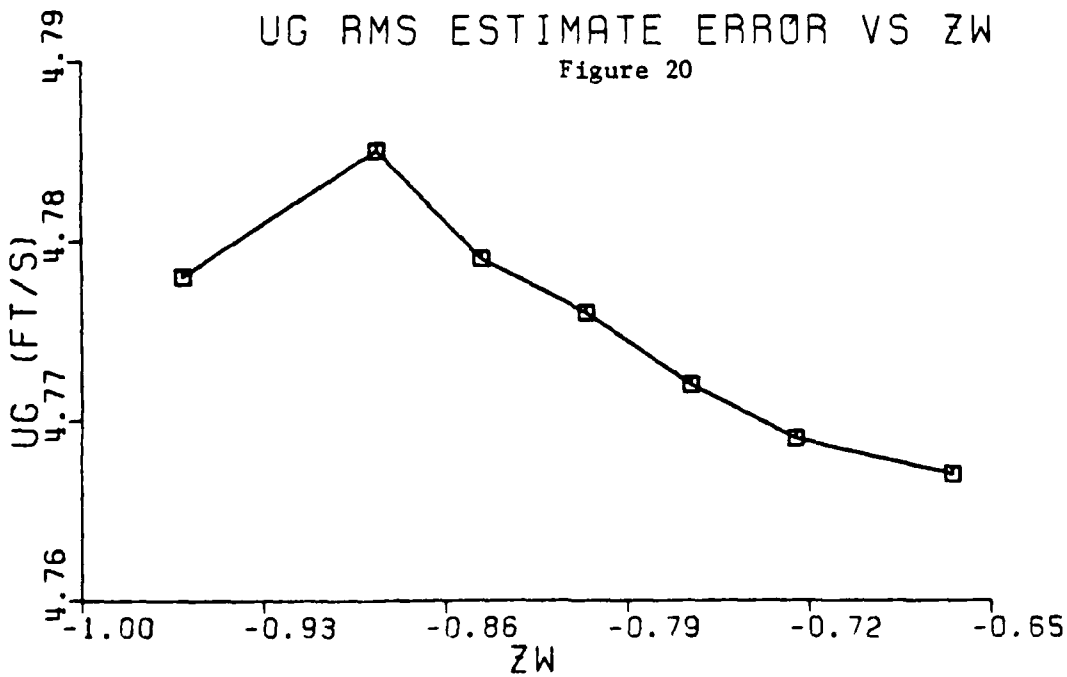

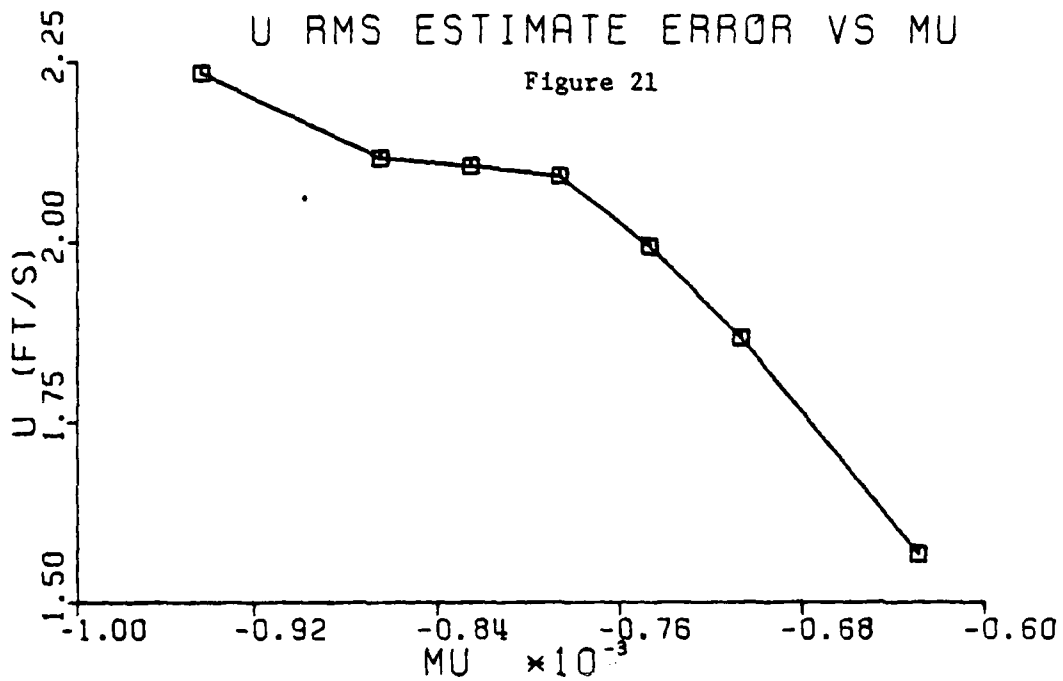

Figures 21 & 22. Sensitivity of \bar{u} and \bar{w} rms estimate errors vs variation in M_u stability derivate.

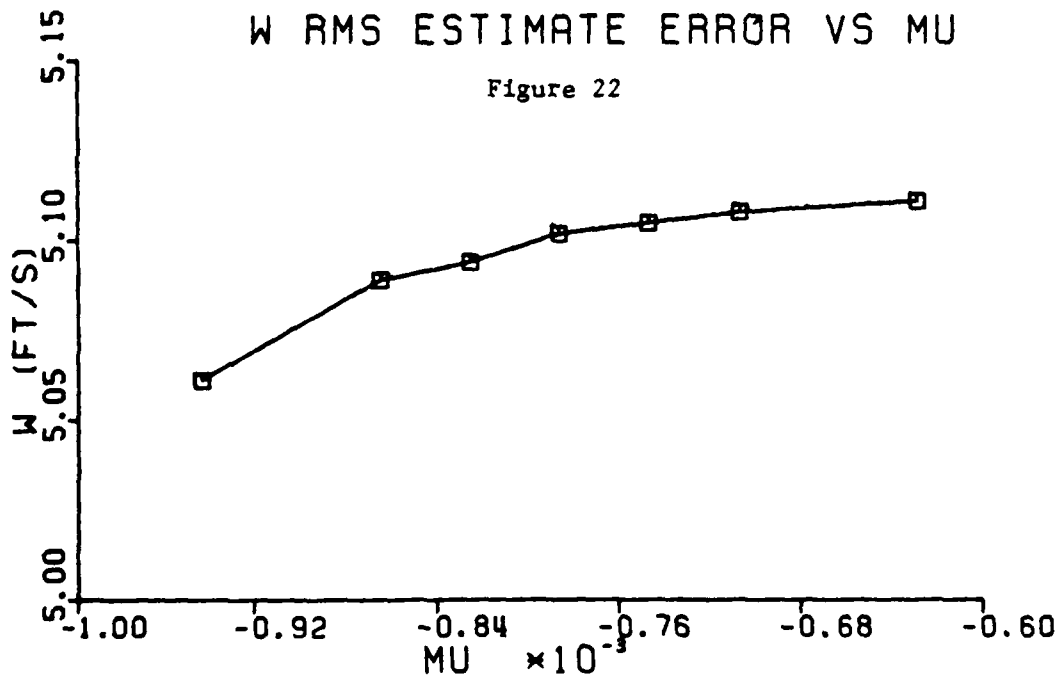

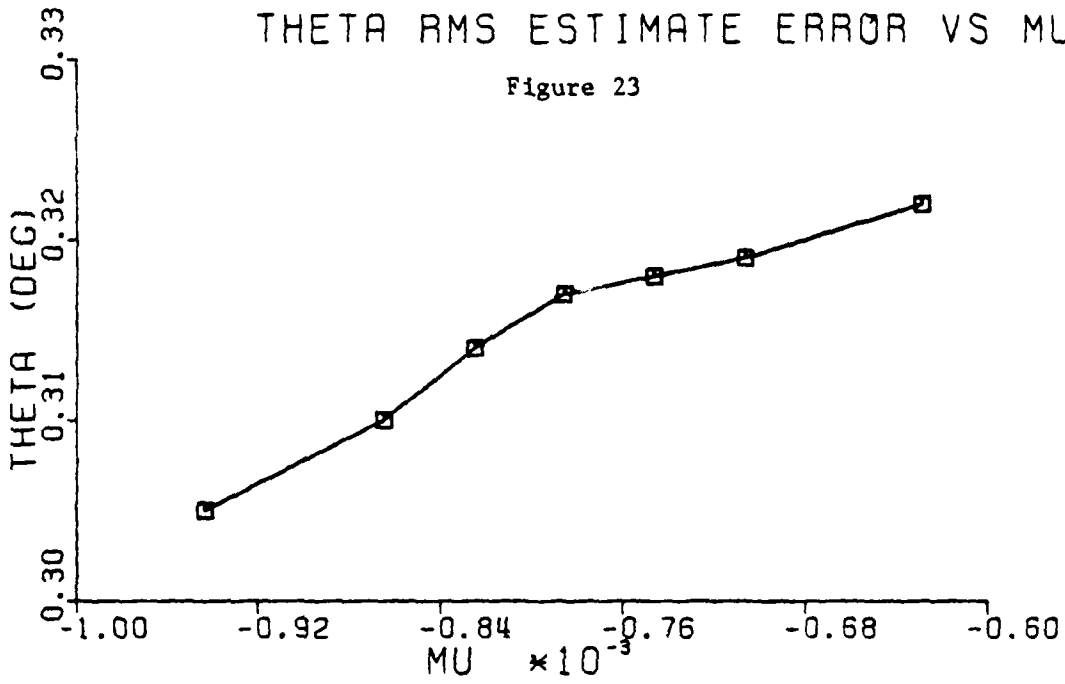

Figures 23 & 24. Sensitivity of $\bar{\theta}$ and \bar{h} rms estimate errors vs variation in Mu stability derivative.

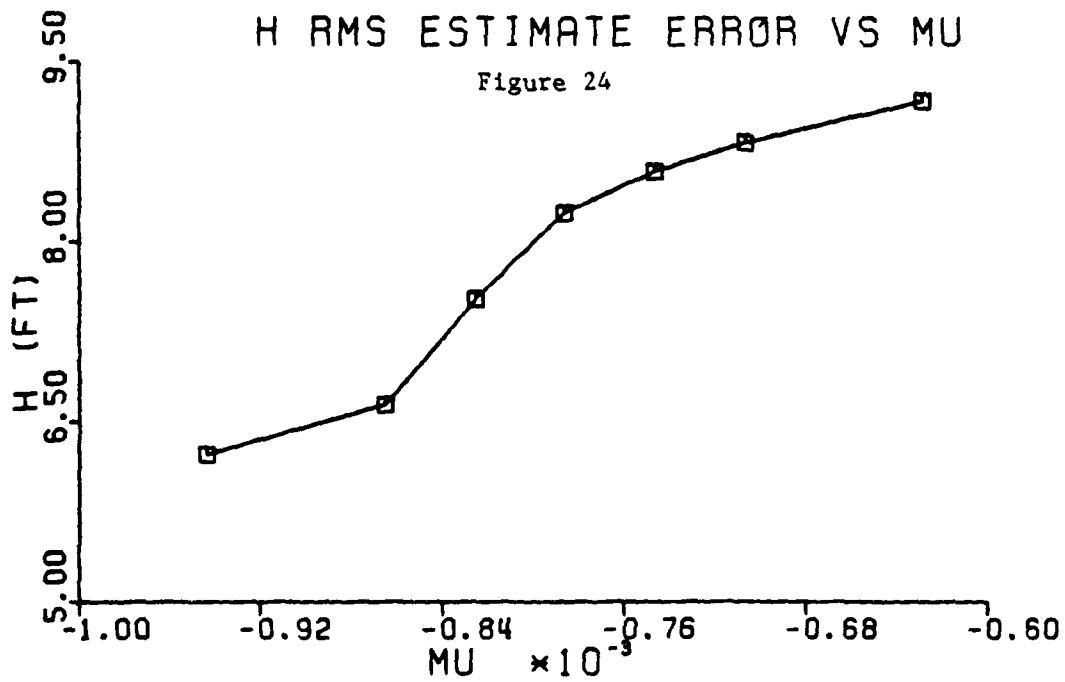

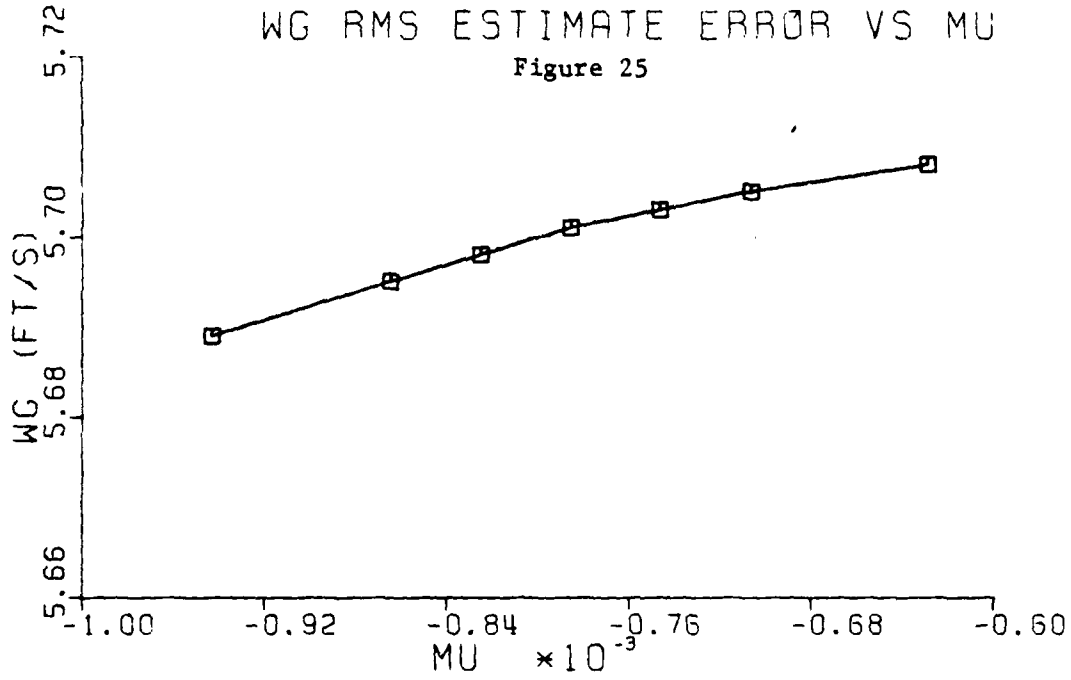

Figures 25 & 26. Sensitivity of \bar{w}_g and \bar{u}_g rms estimate errors vs variation in Mu stability derivative.

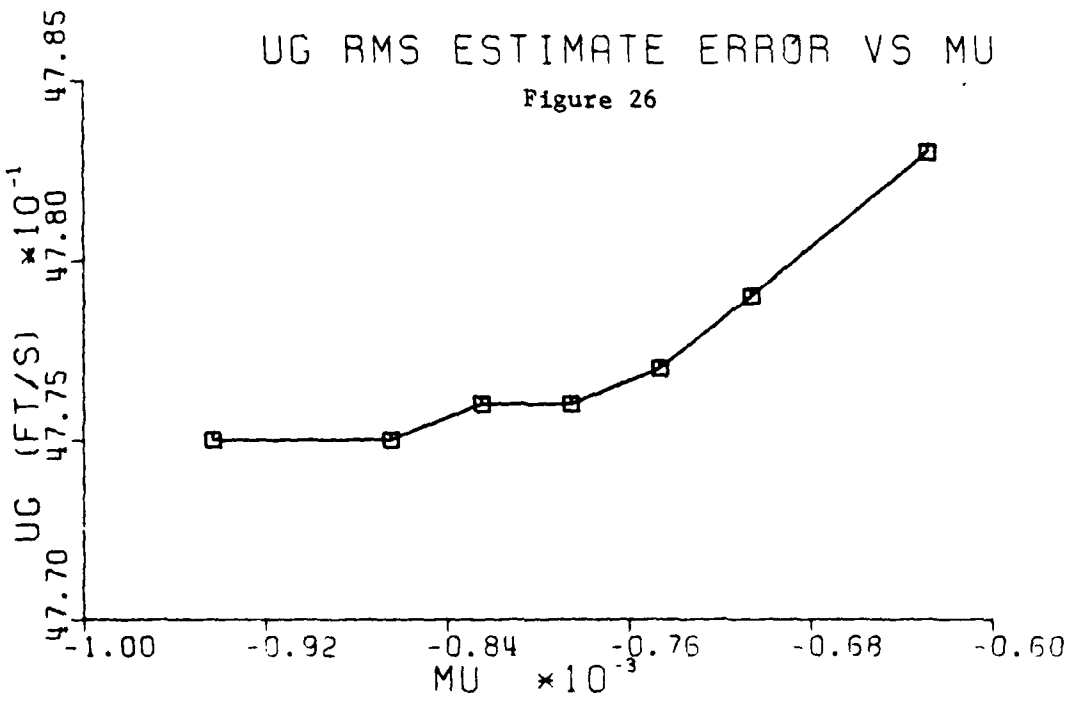

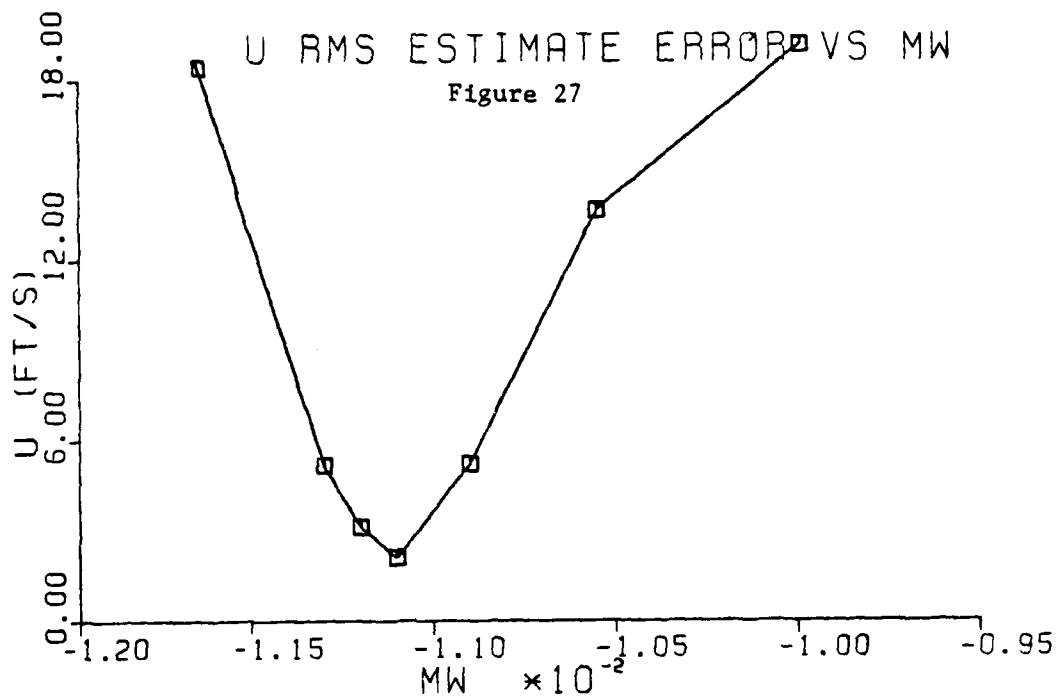

Figures 27 & 28. Sensitivity of \bar{u} and \bar{w} rms estimate errors vs variation in M_w stability derivative.

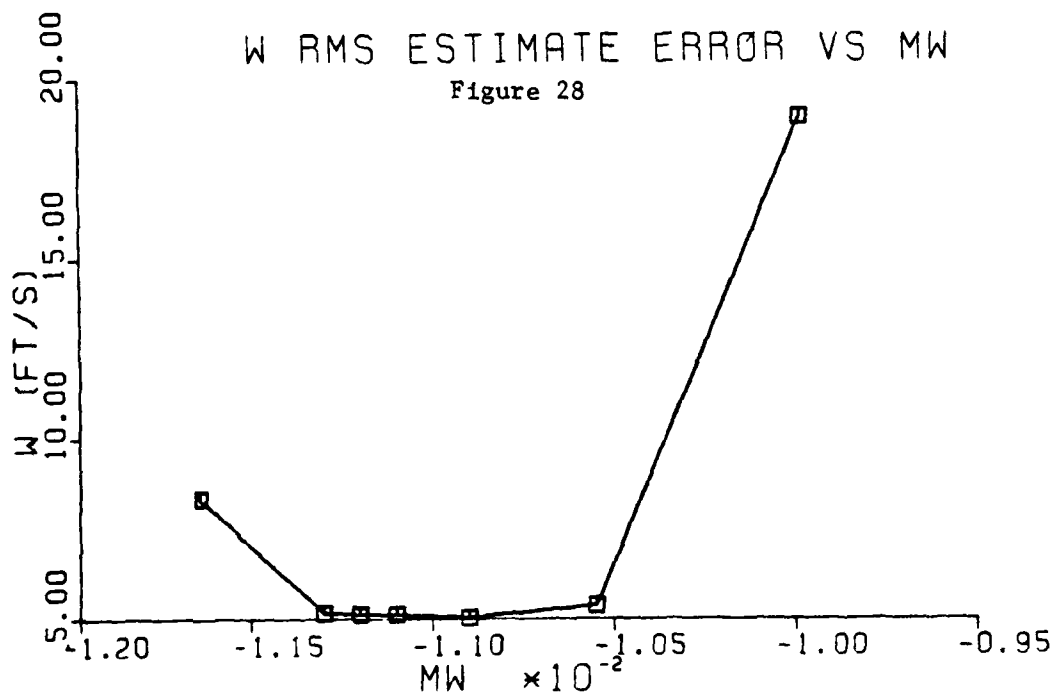

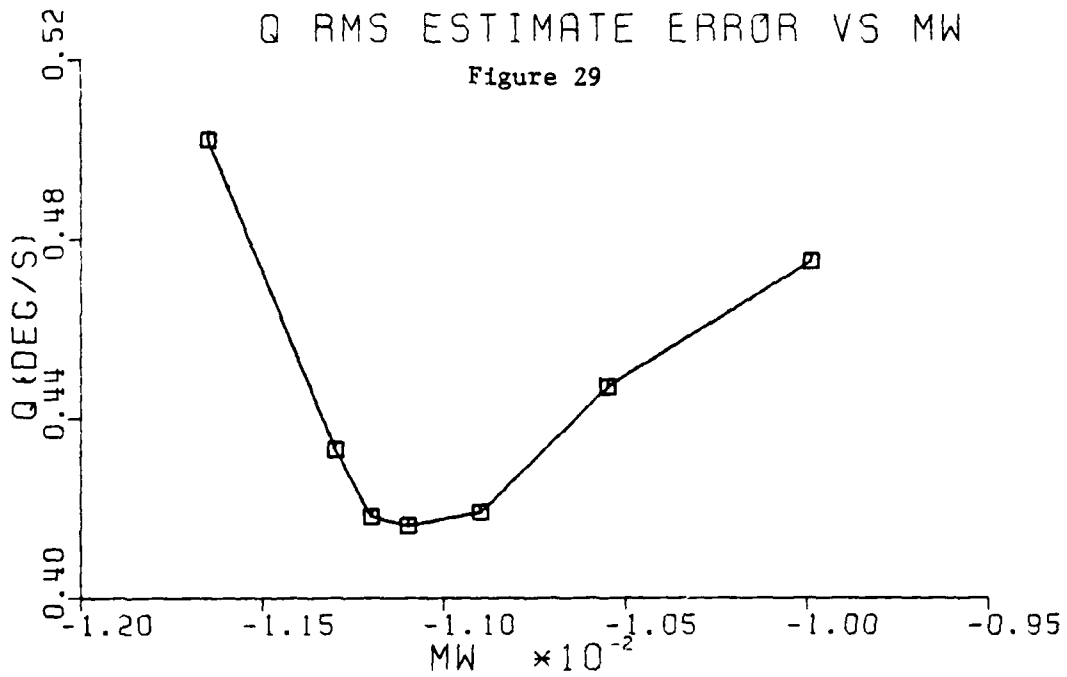

Figures 29 & 30. Sensitivity of \bar{q} and $\bar{\theta}$ rms estimate errors vs variation in Mw stability derivative.

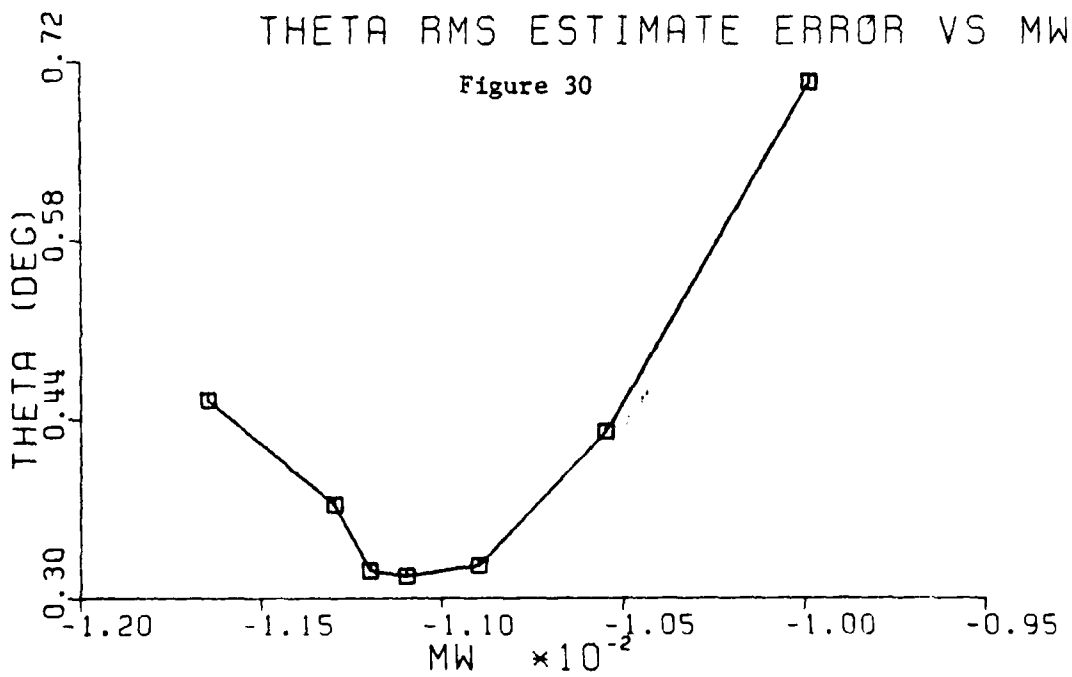

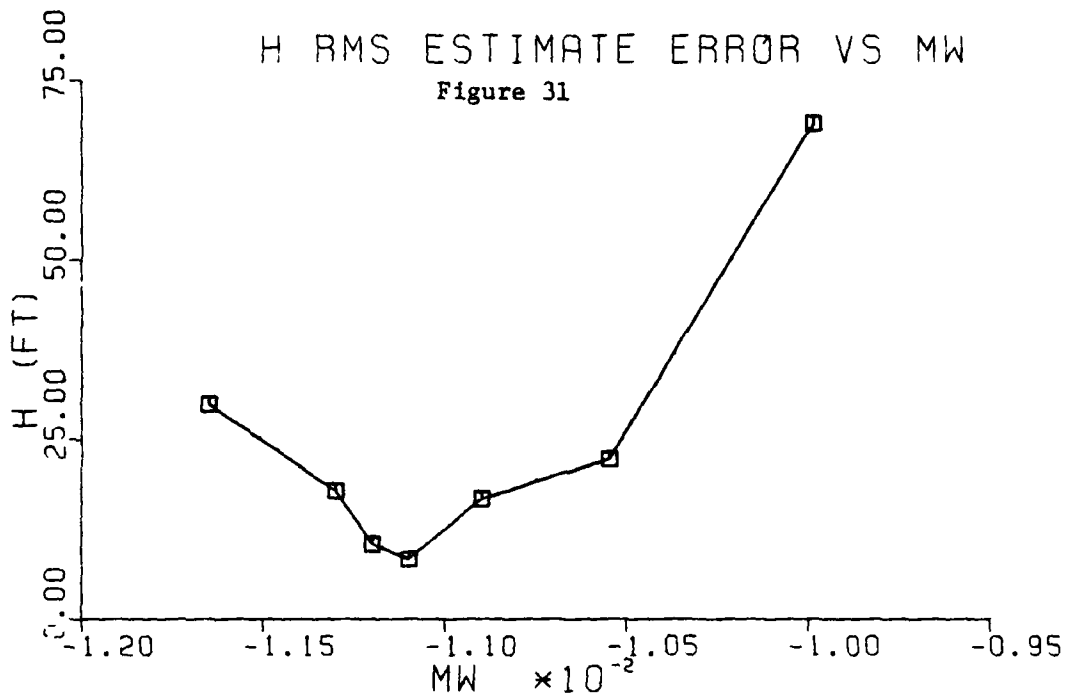

Figures 31 & 32. Sensitivity of \bar{h} and \bar{w}_g rms estimate errors vs variation in Mw stability derivative.

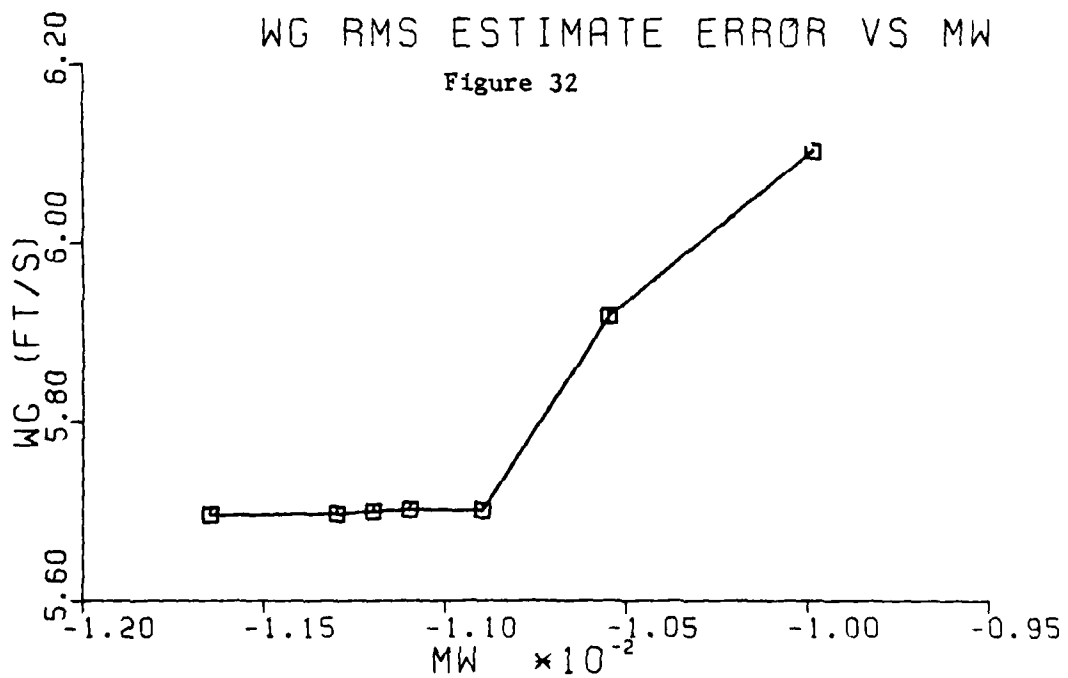

U RMS ESTIMATE ERROR VS MQ

Figure 33

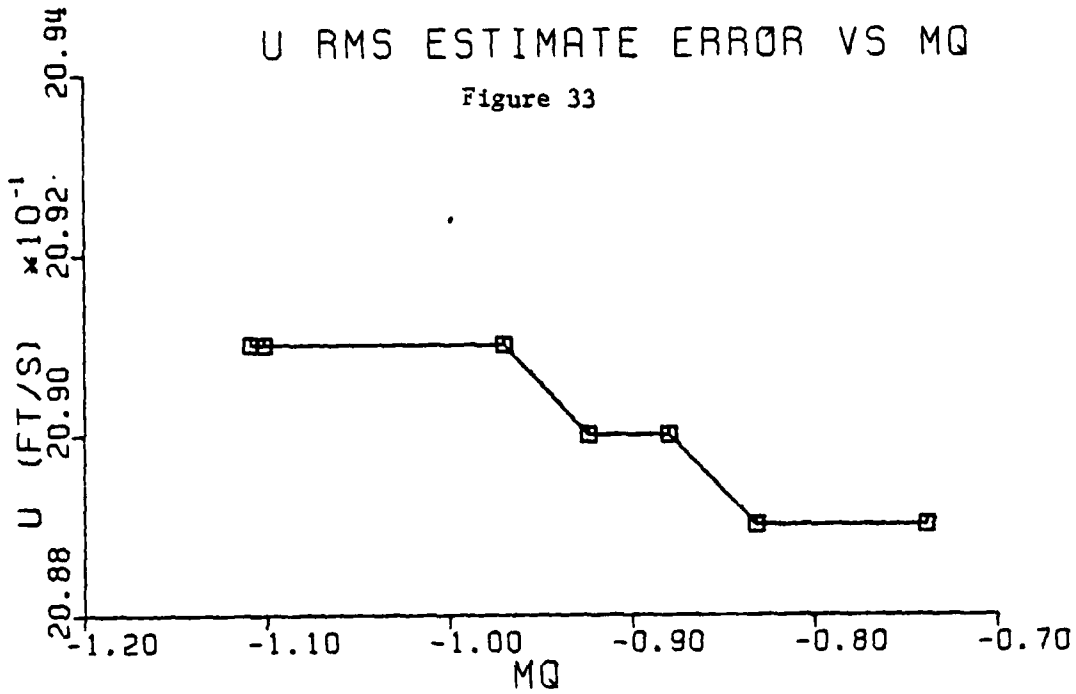

Figures 33 & 34. Sensitivity of \bar{u} and \bar{h} rms estimate errors vs variation in M_q stability derivative.

H RMS ESTIMATE ERROR VS MQ

Figure 34

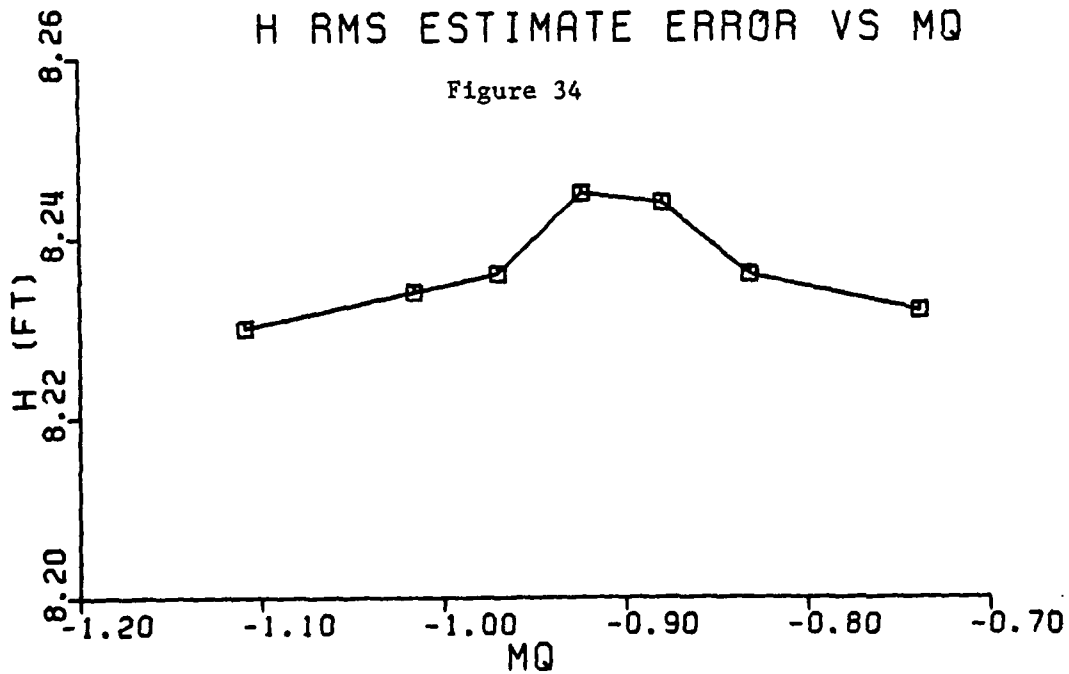

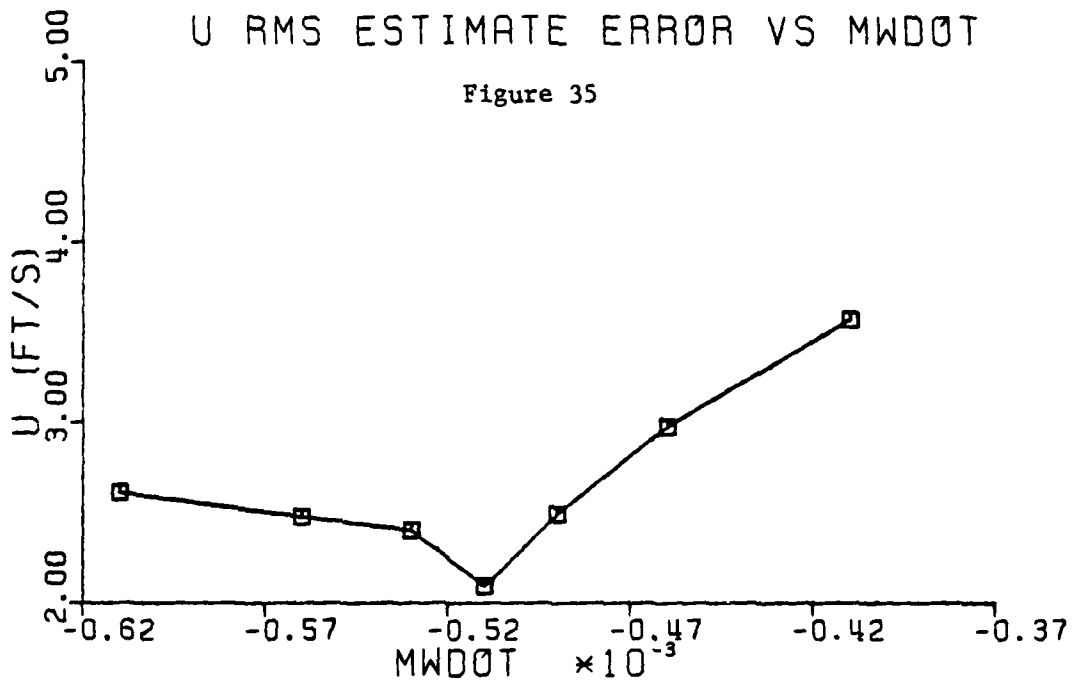

Figures 35 & 36. Sensitivity of \bar{u} and \bar{w} rms estimate errors vs variation in $M\dot{w}$ stability derivatives.

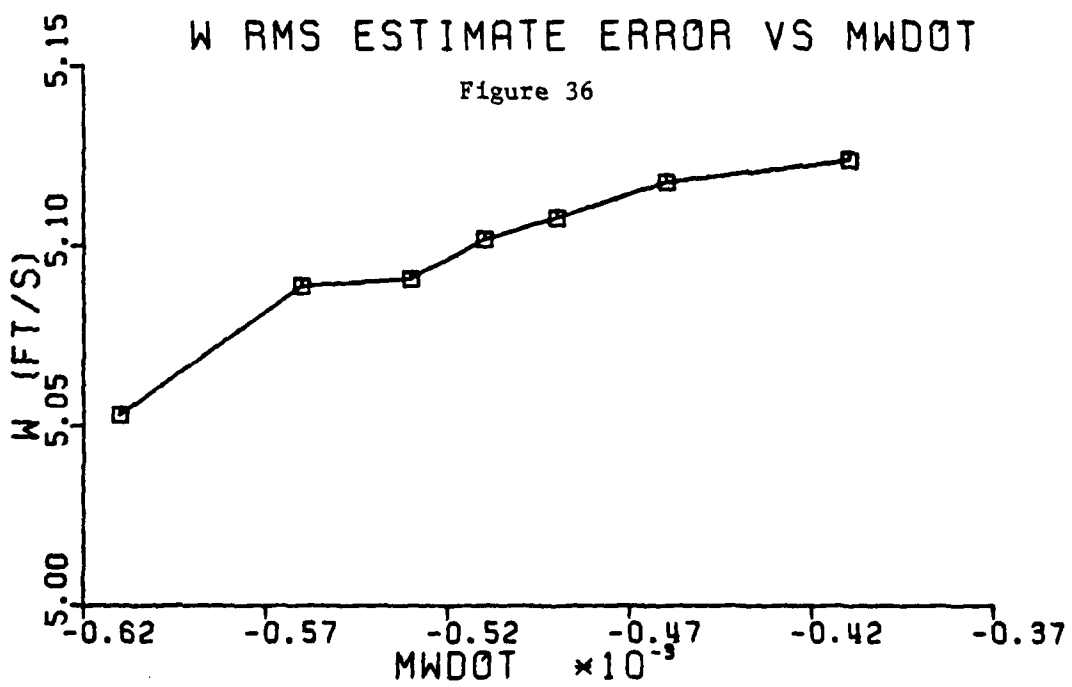

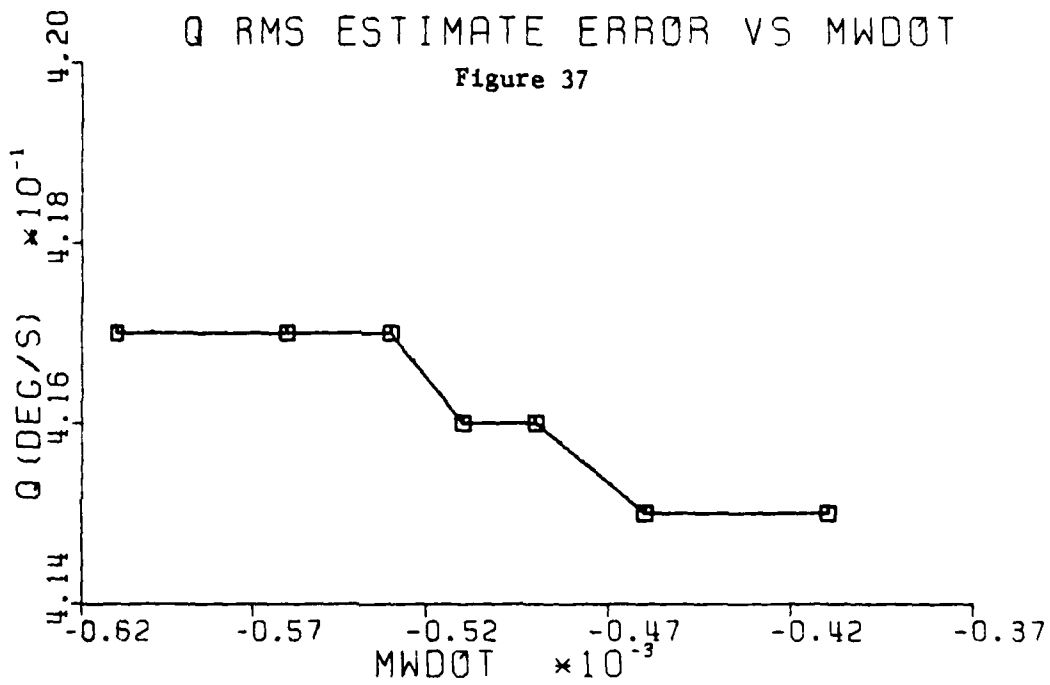

Figures 37 & 38. Sensitivity of \bar{q} and $\bar{\theta}$ rms estimate errors vs variation in $M\dot{w}$ stability derivative.

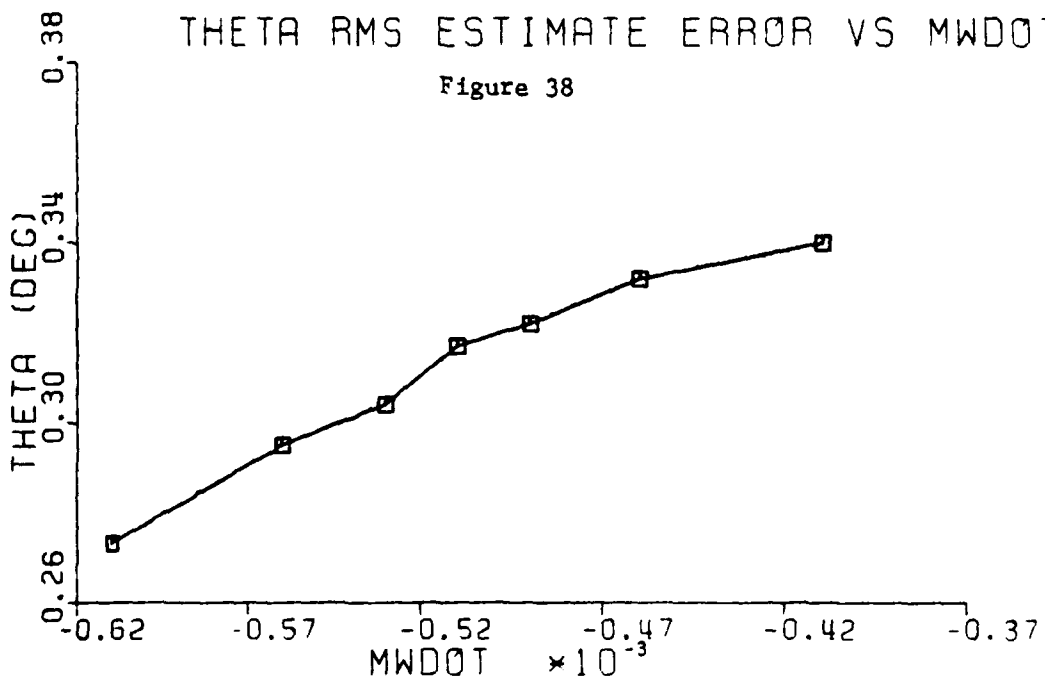

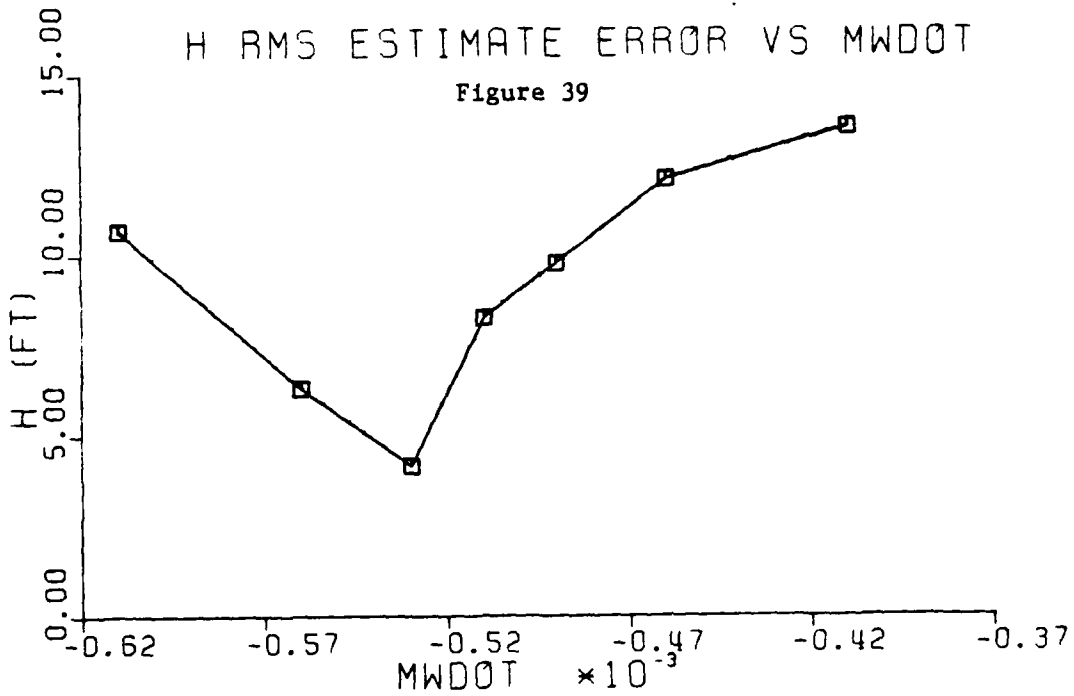

Figures 39 & 40. Sensitivity of \bar{h} and \bar{w}_g rms estimate errors vs variation of $M\dot{w}$ stability derivative.

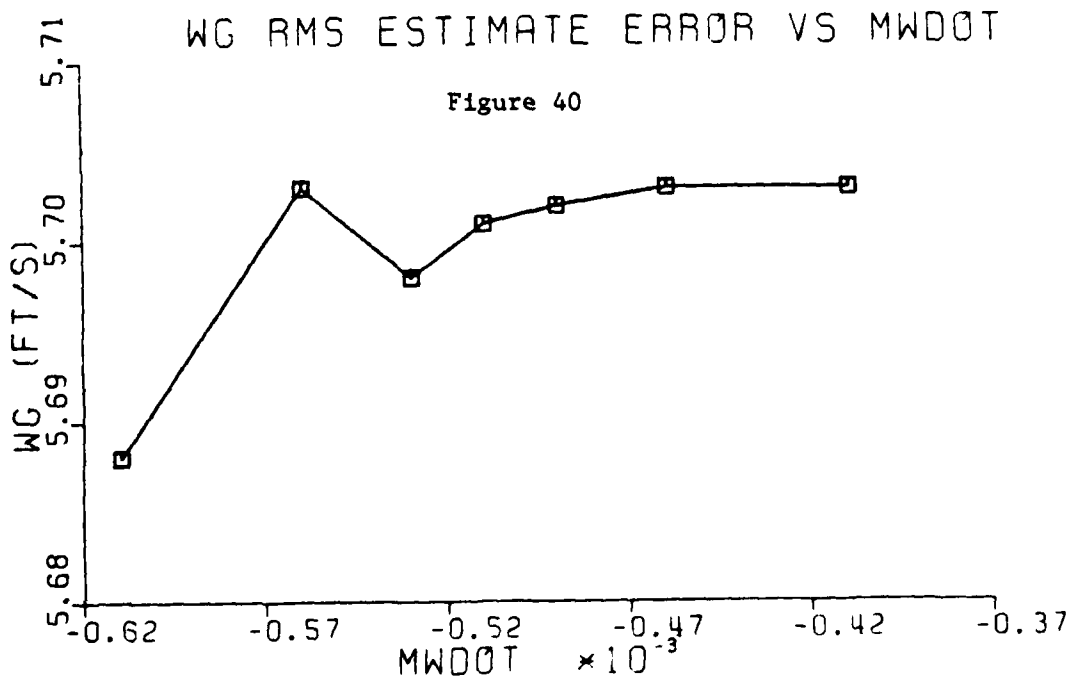

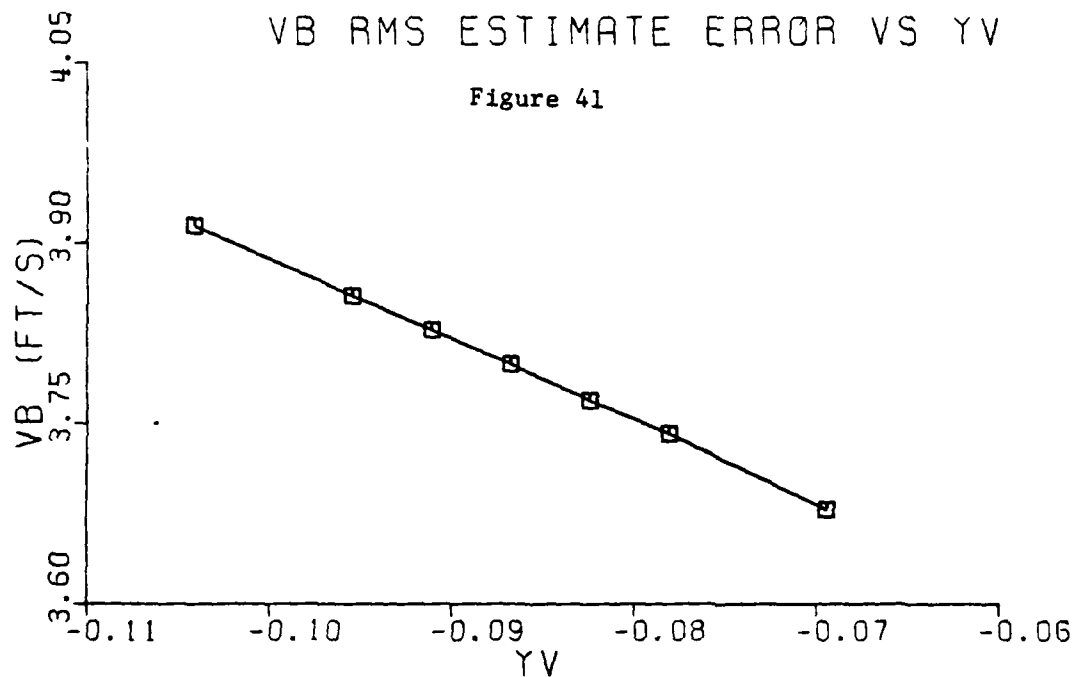

Figures 41 & 42. Sensitivity of $V\bar{\beta}$ and \bar{p} rms estimate errors vs variation in Yv stability derivative.

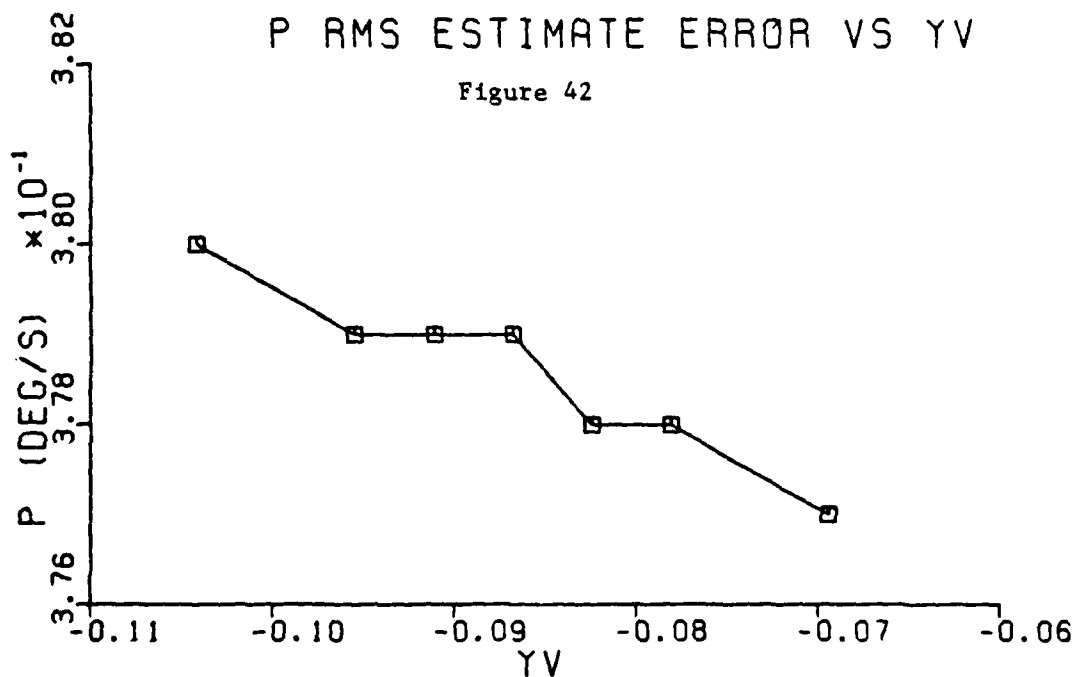

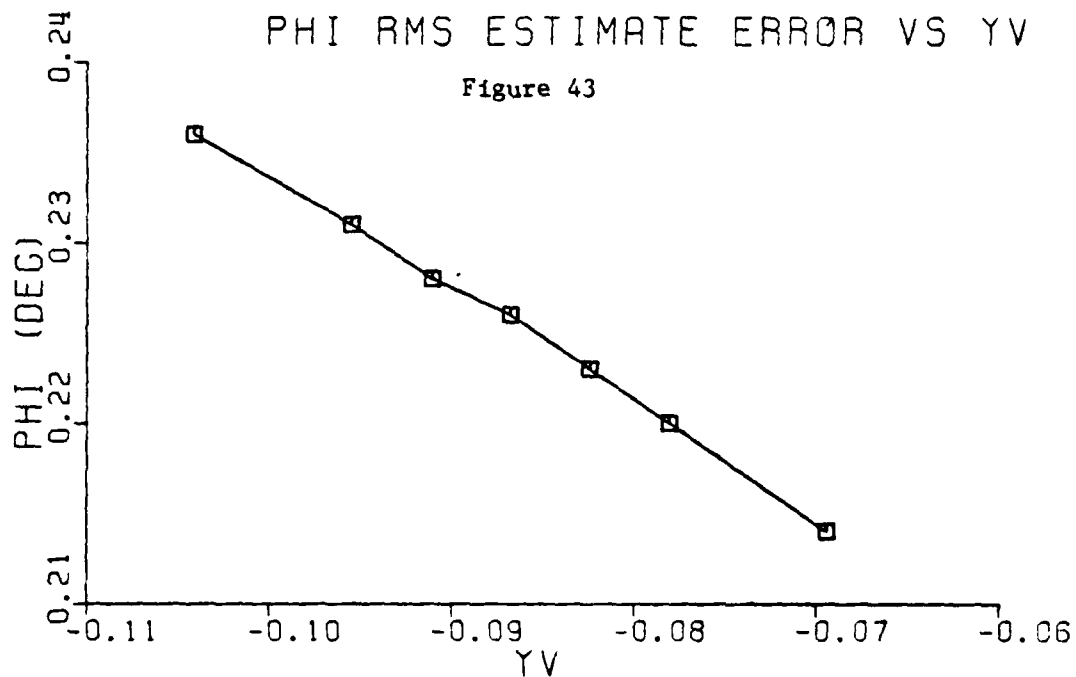

Figures 43 & 44. Sensitivity of $\bar{\theta}$ and $V\bar{\beta}_g$ rms estimate errors vs variation in Yv stability derivative.

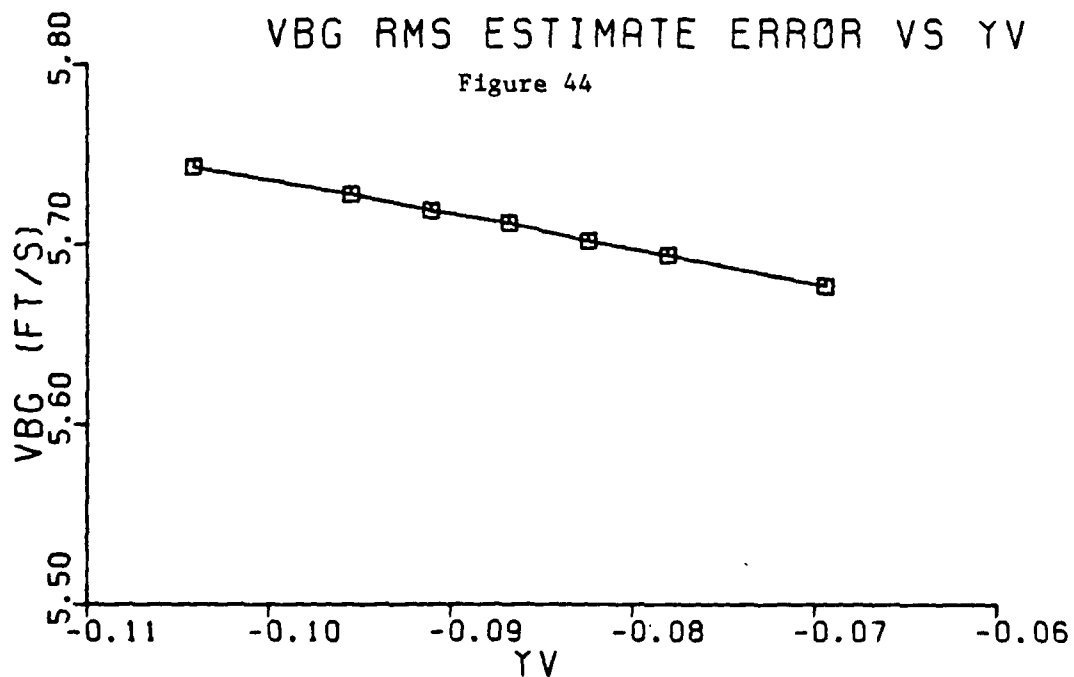

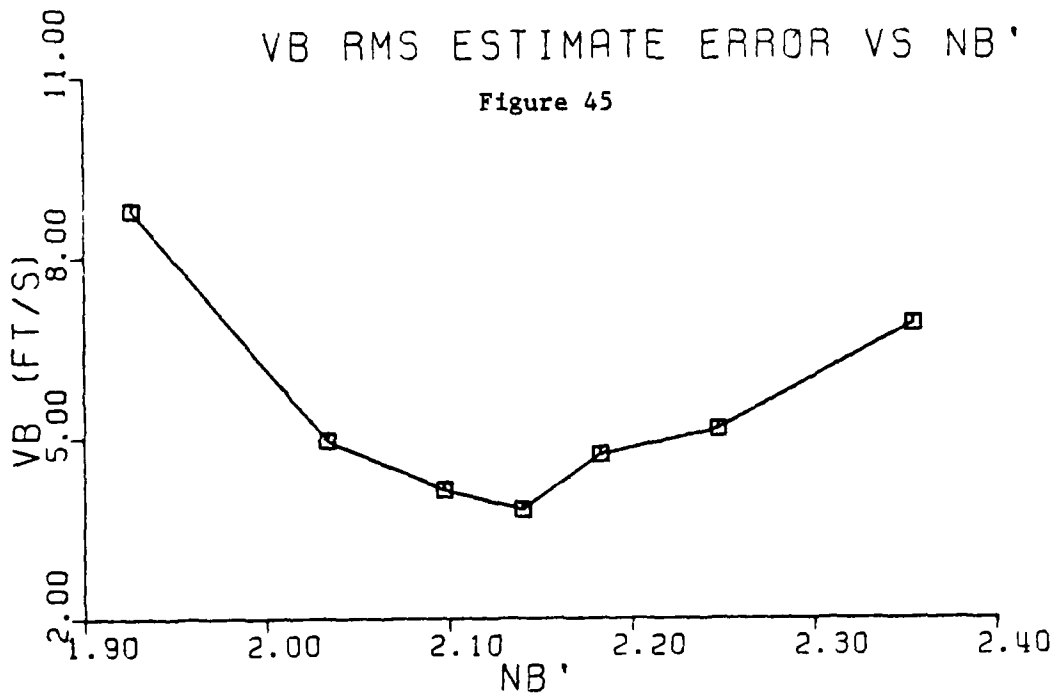

Figures 45 & 46. Sensitivity of \bar{V}_β and \bar{r} rms estimate errors vs variation in N_β' stability derivative.

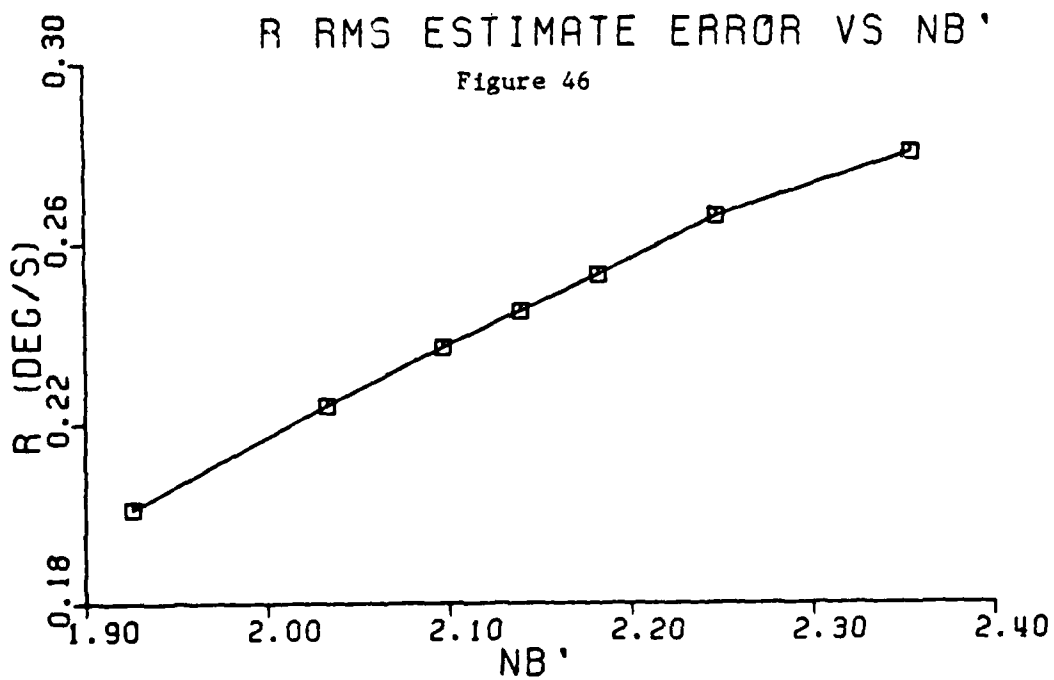

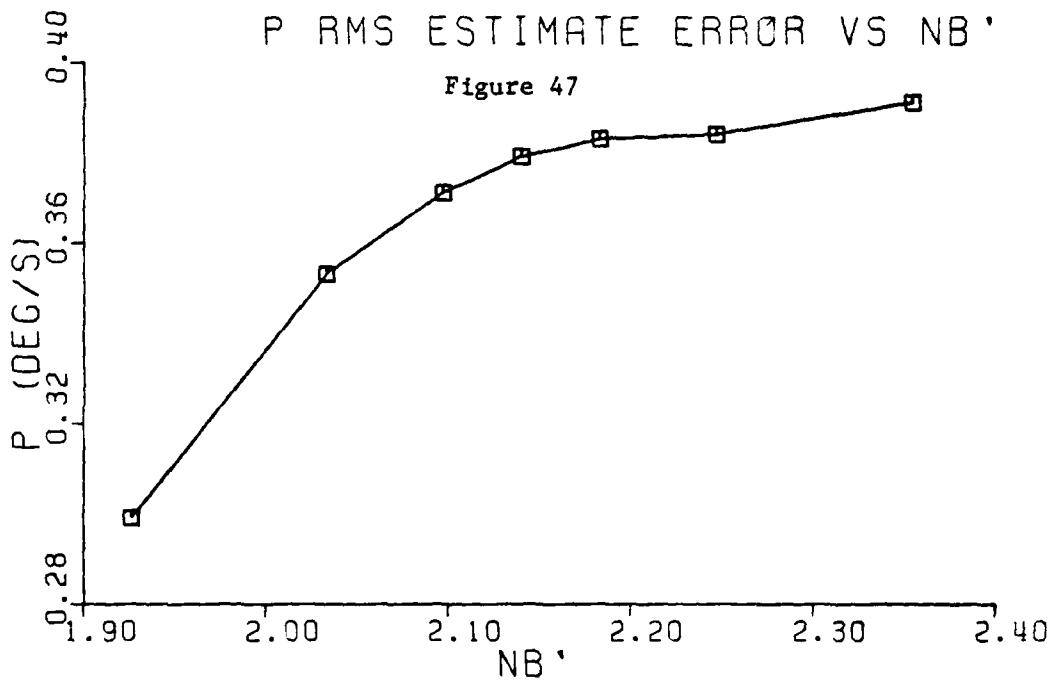

Figures 47 & 48. Sensitivity of \bar{p} and $\bar{\theta}$ rms estimate errors vs variation of N_{β}' stability derivative.

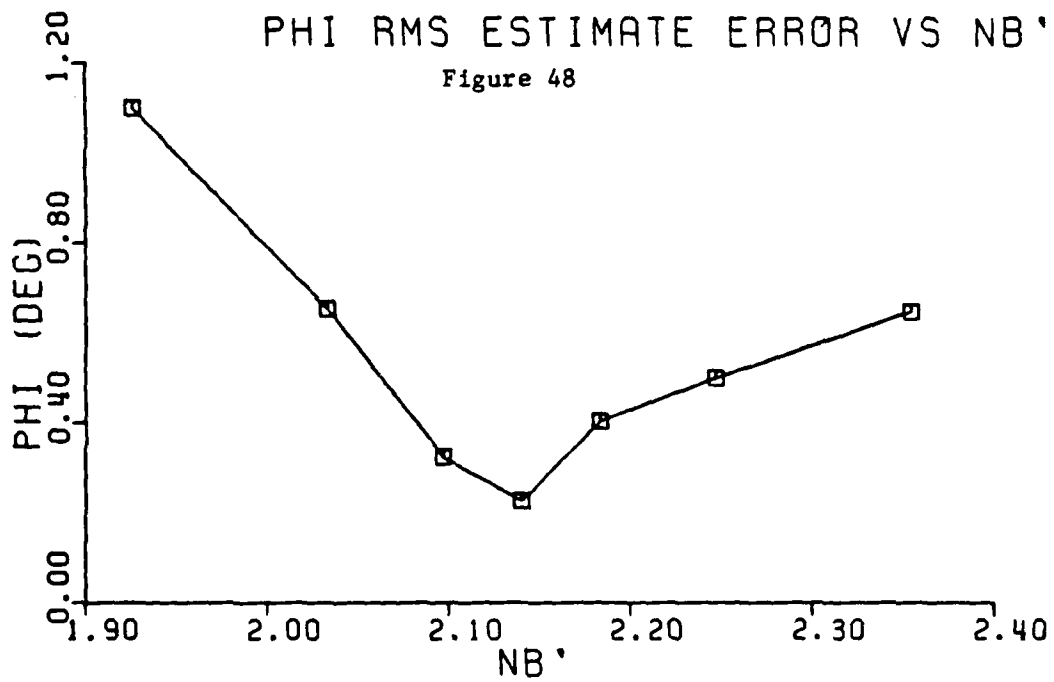

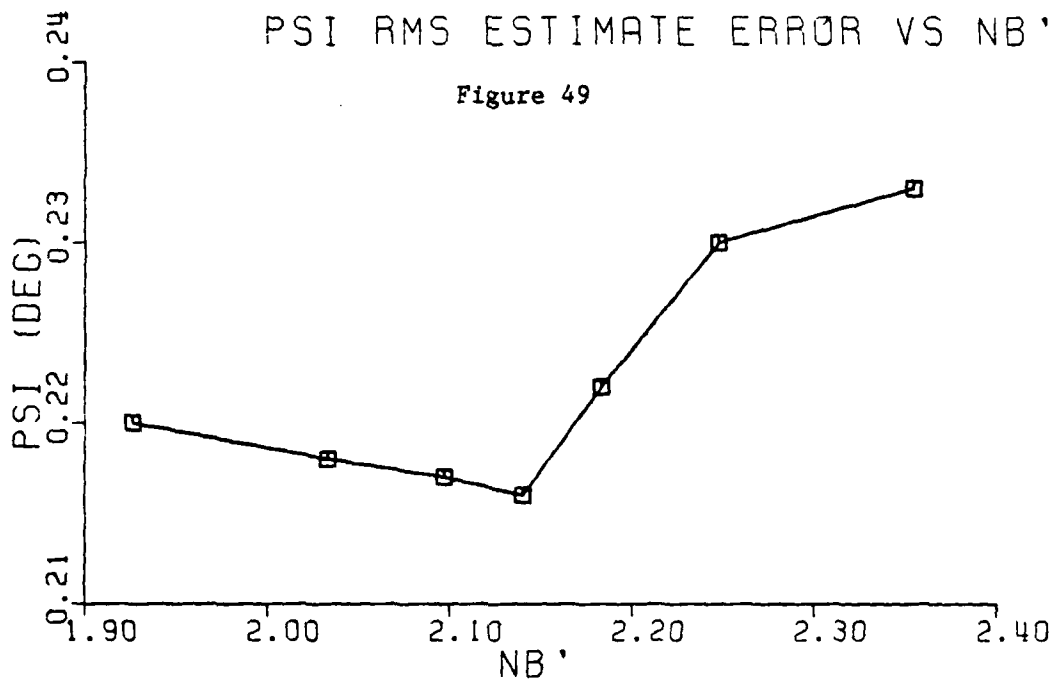

Figures 49 & 50. Sensitivity of $\bar{\Psi}$ and \bar{V}_{β_g} rms estimate errors vs variation in N'_g stability derivative.

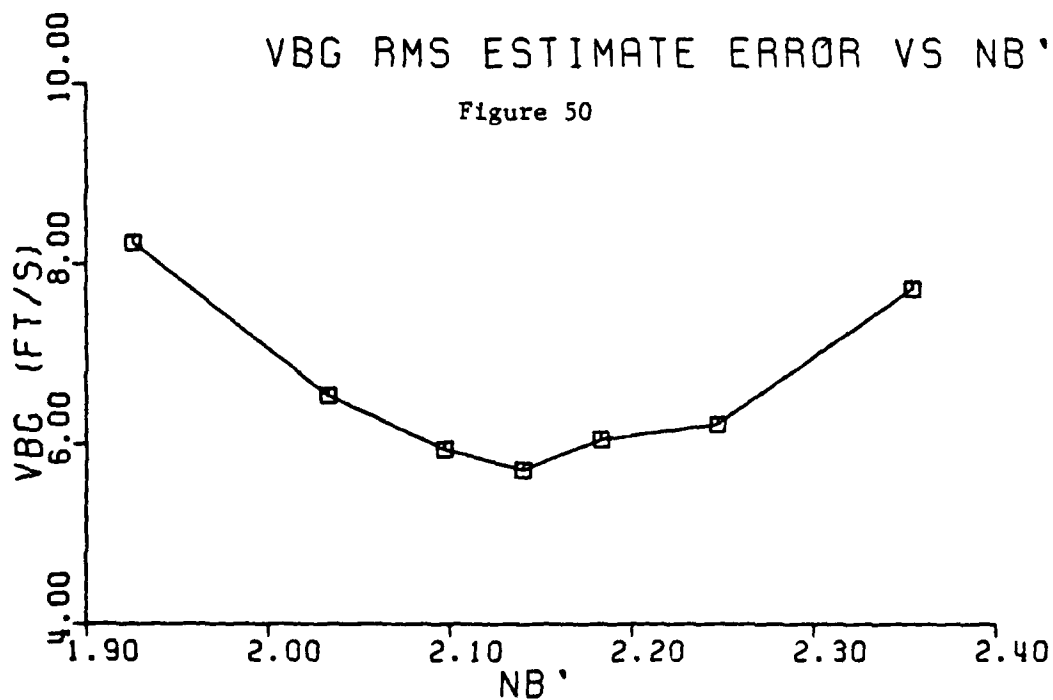



Figures 51 & 52. Sensitivity of \bar{V}_B and \bar{r} rms estimate errors vs variation in N_r' stability derivative.

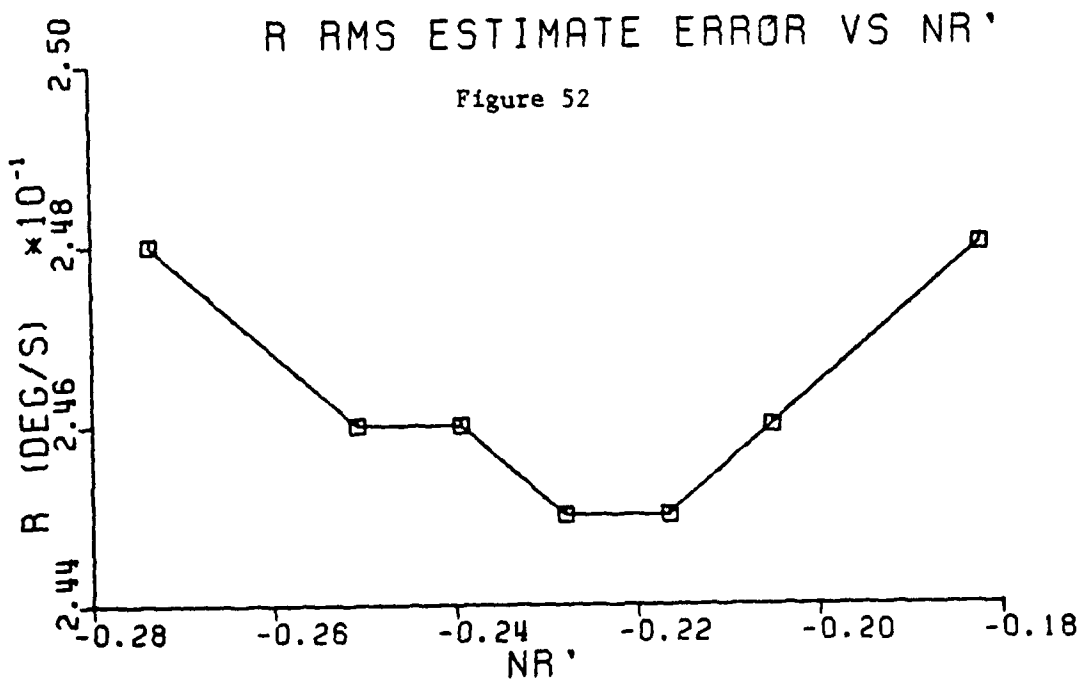

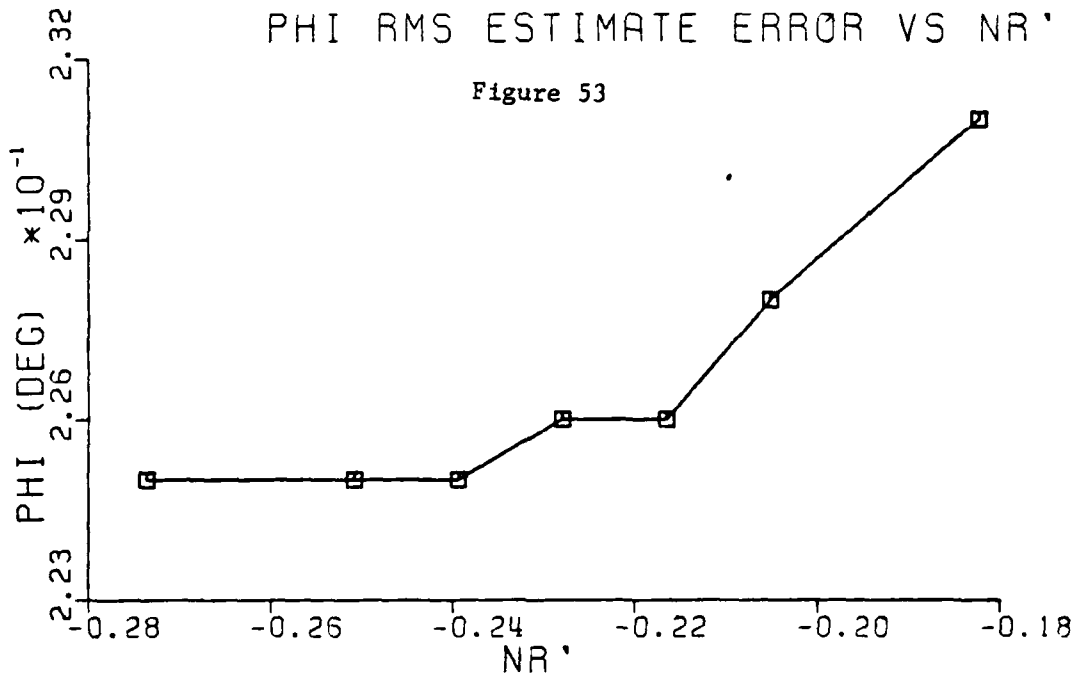

Figures 53 & 54. Sensitivity of $\bar{\theta}$ and $V_{\beta\beta}$ rms estimate errors vs variation in N_r' stability derivative.

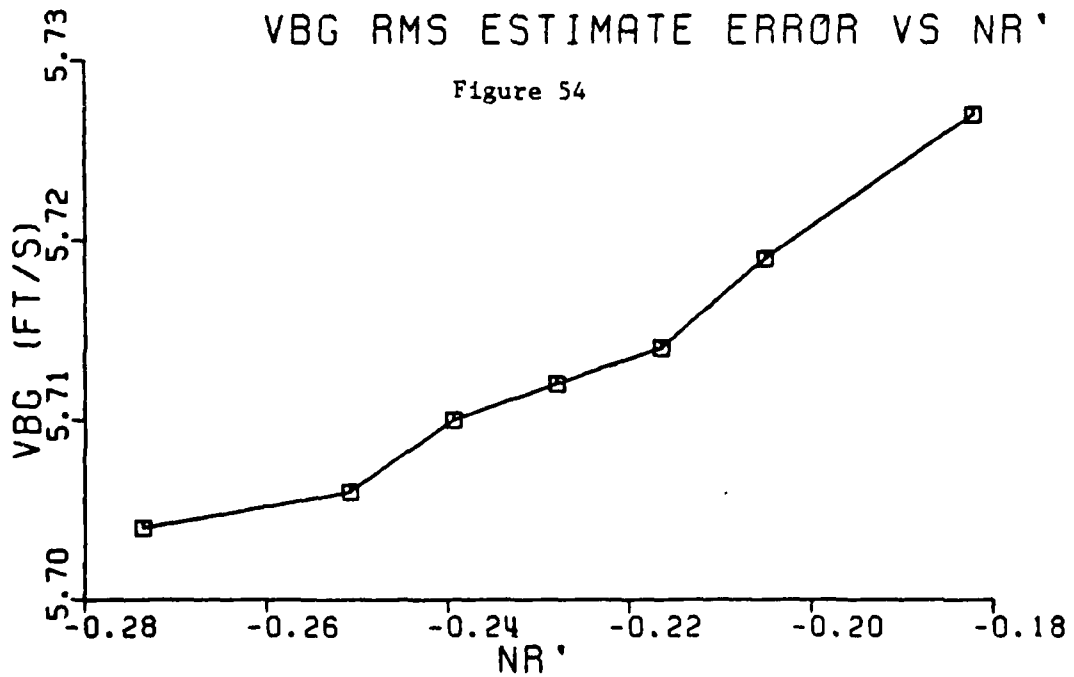

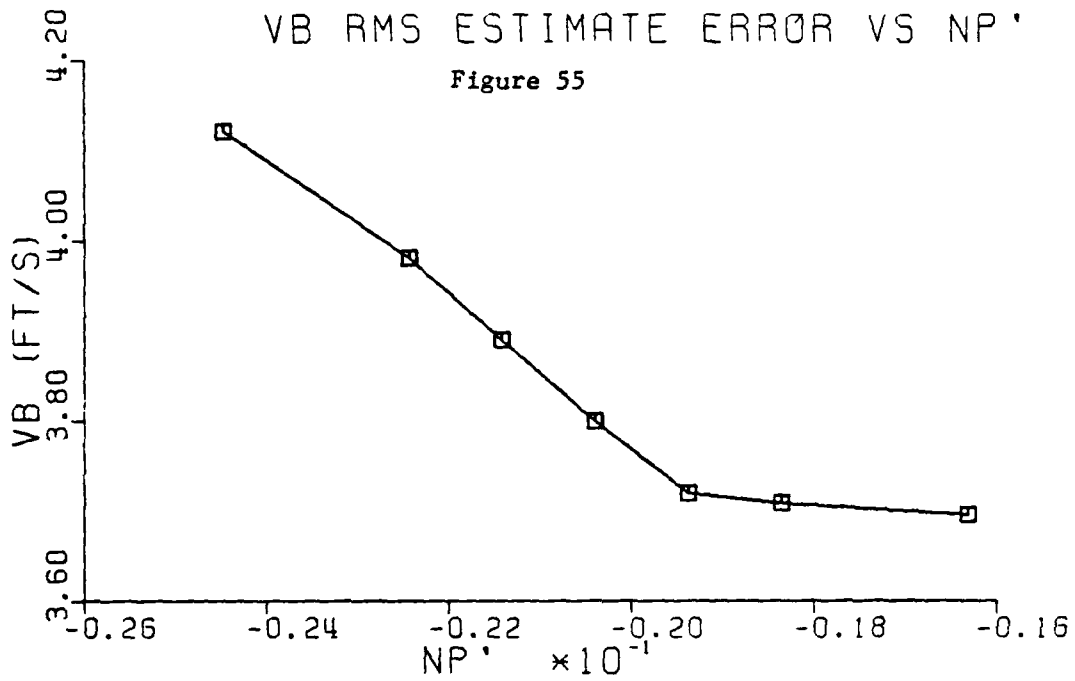

Figures 55 & 56. Sensitivity of \bar{V}_β and \bar{r} rms estimate errors vs variation in N'_p stability derivative.

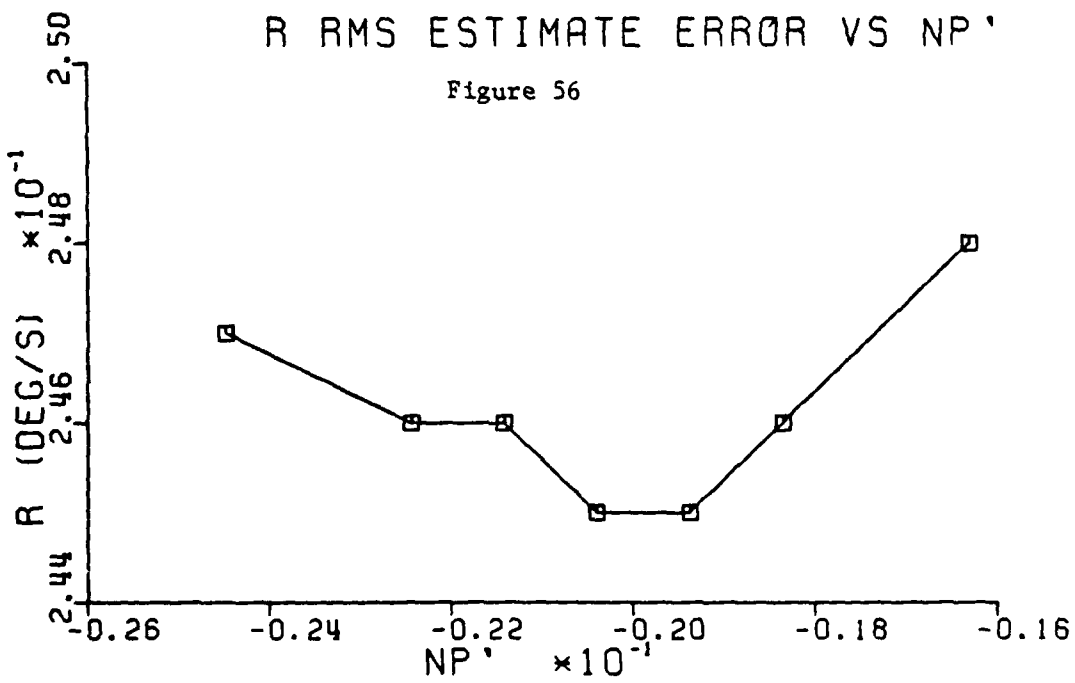

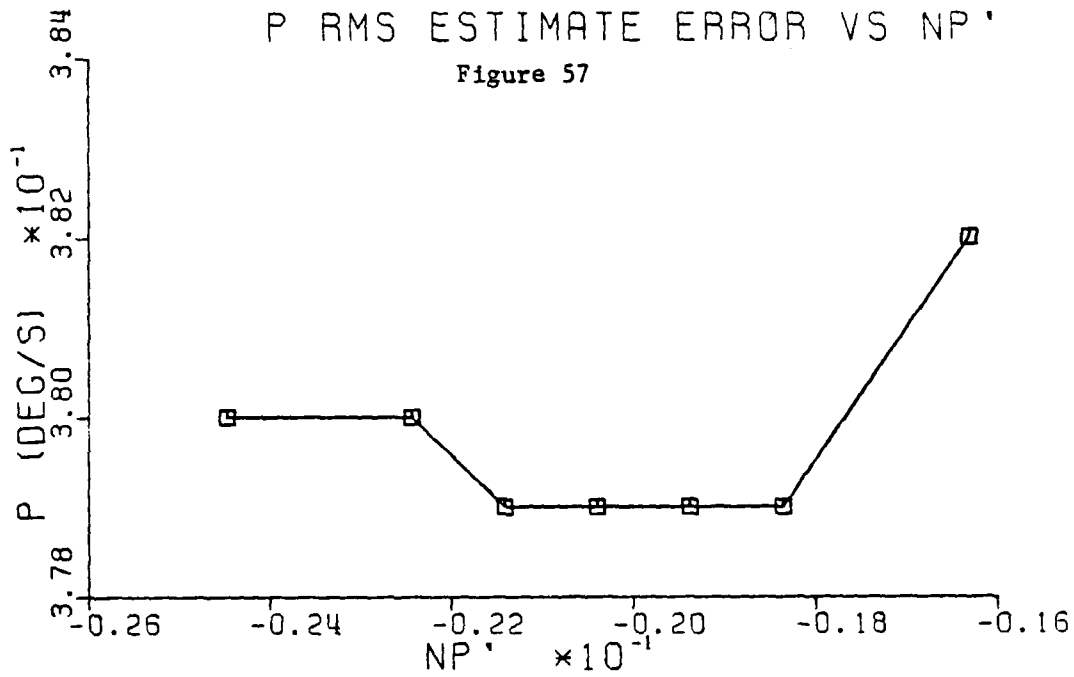

Figures 57 & 58. Sensitivity of \bar{p} and $\bar{\theta}$ rms estimate errors vs variation of N'_p stability derivative.

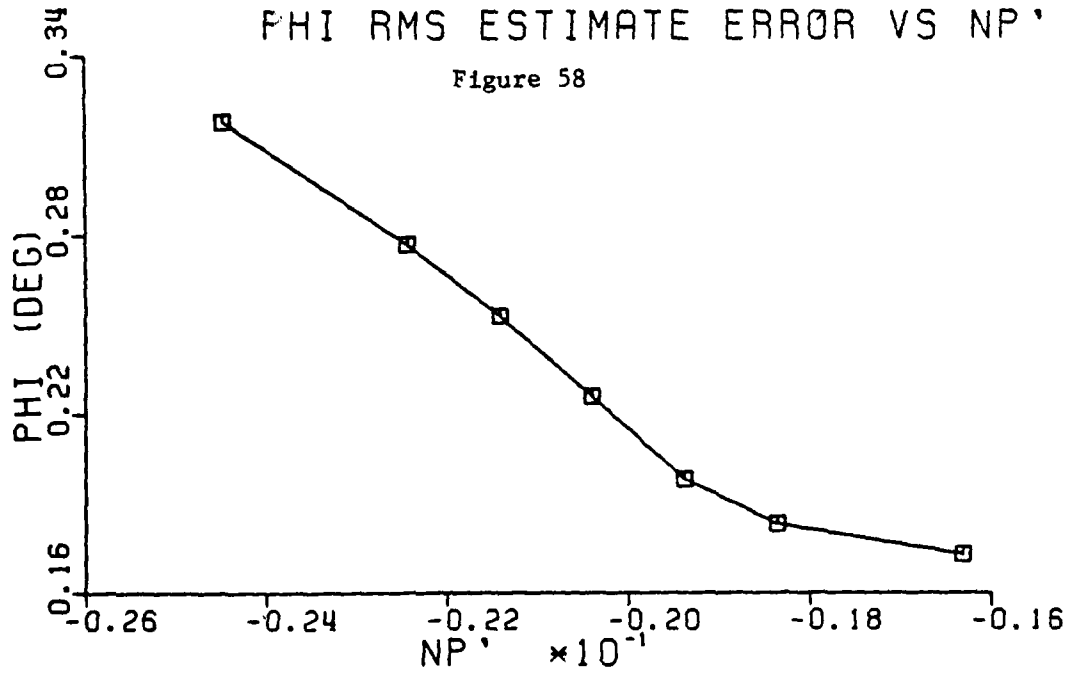

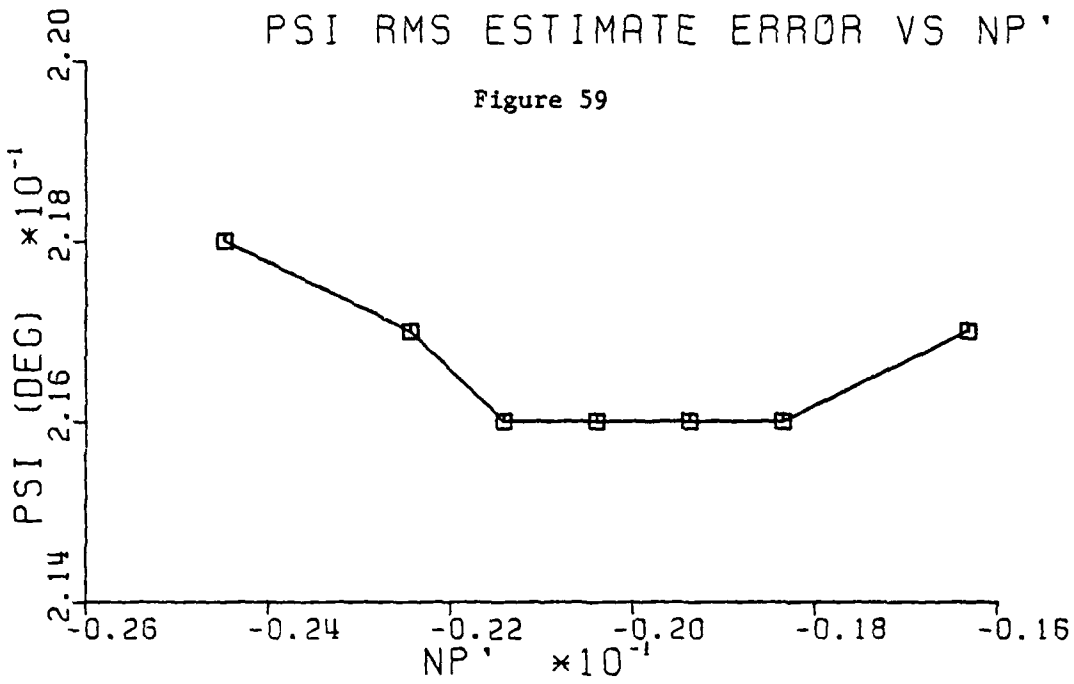

Figures 59 & 60. Sensitivity of $\bar{\psi}$ and V_{β_0} rms estimate errors vs variation in N'_p stability derivative.

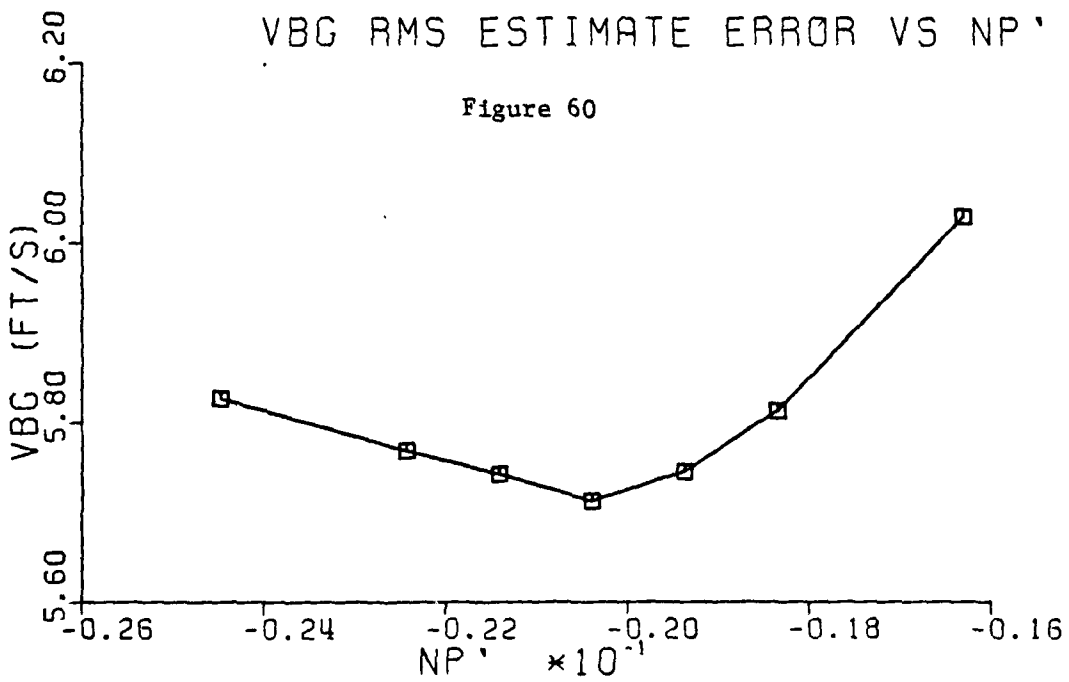

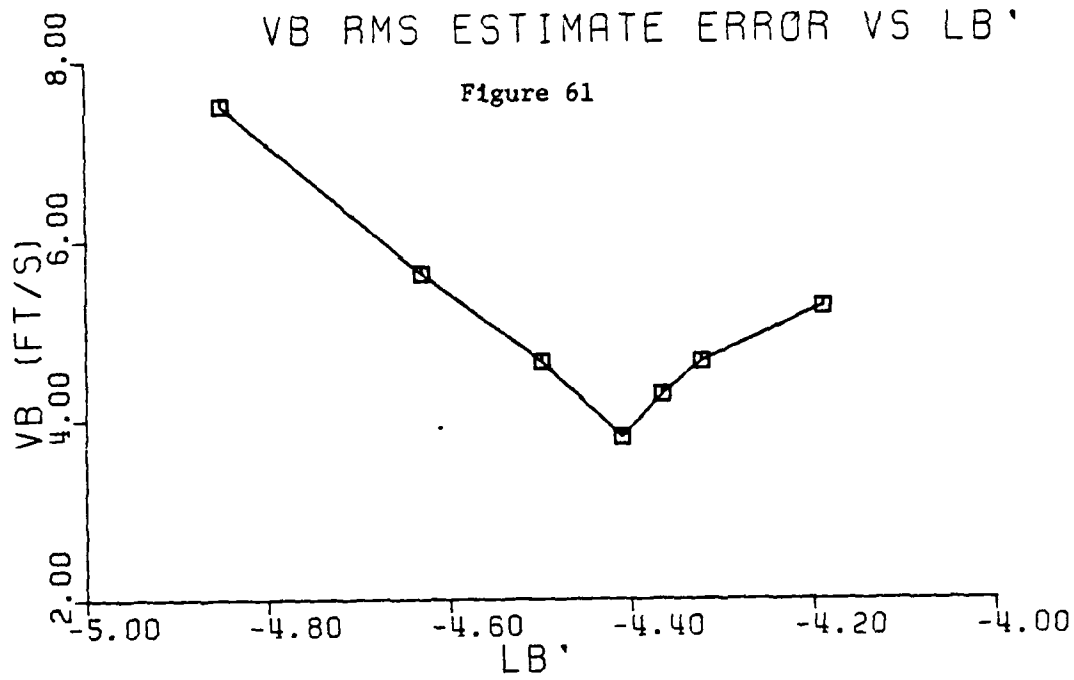

Figures 61 & 62. Sensitivity of V_{β} and \bar{r} rms estimate errors vs variation L_{β}' stability derivative.

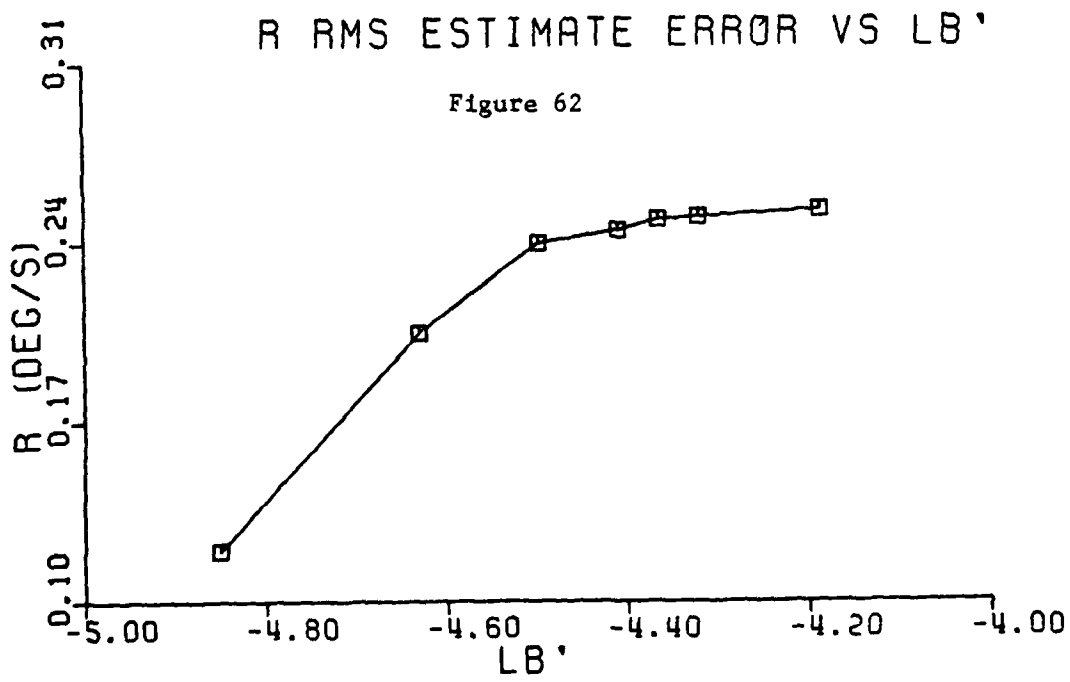

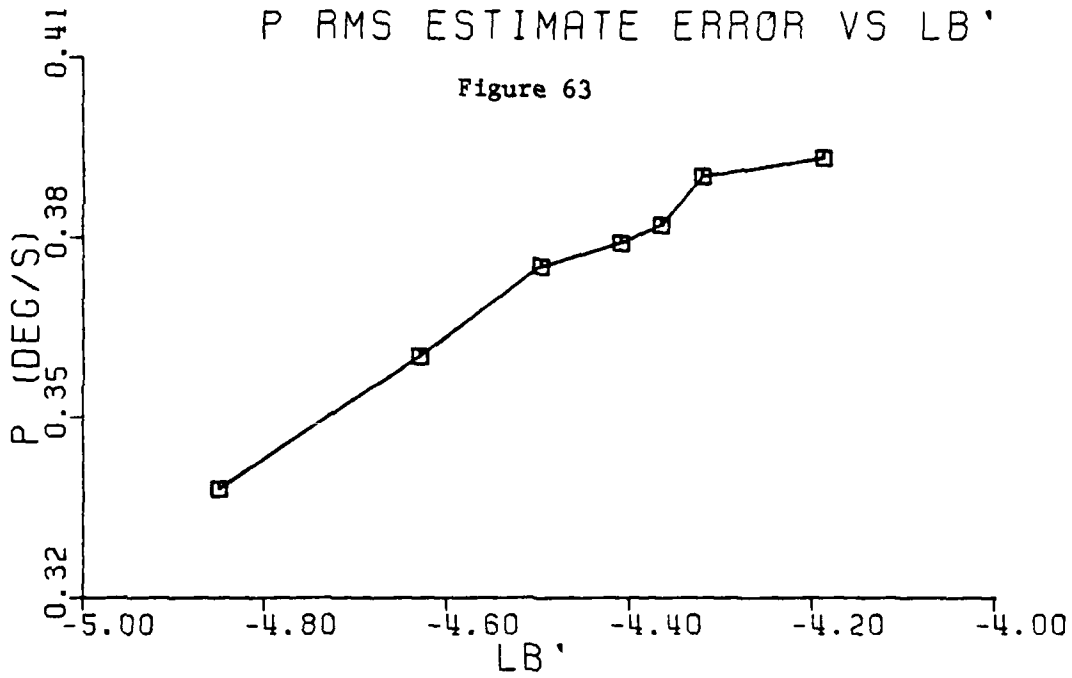

Figures 63 & 64. Sensitivity of \bar{p} and $\bar{\theta}$ rms estimate errors vs variation in L'_β stability derivative.

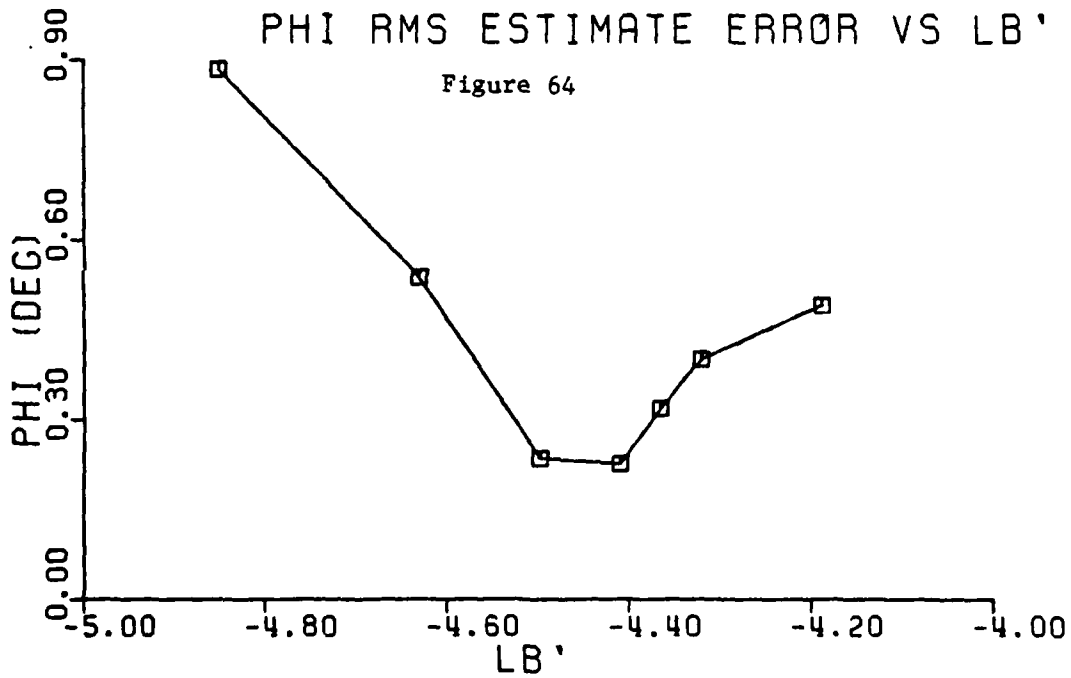

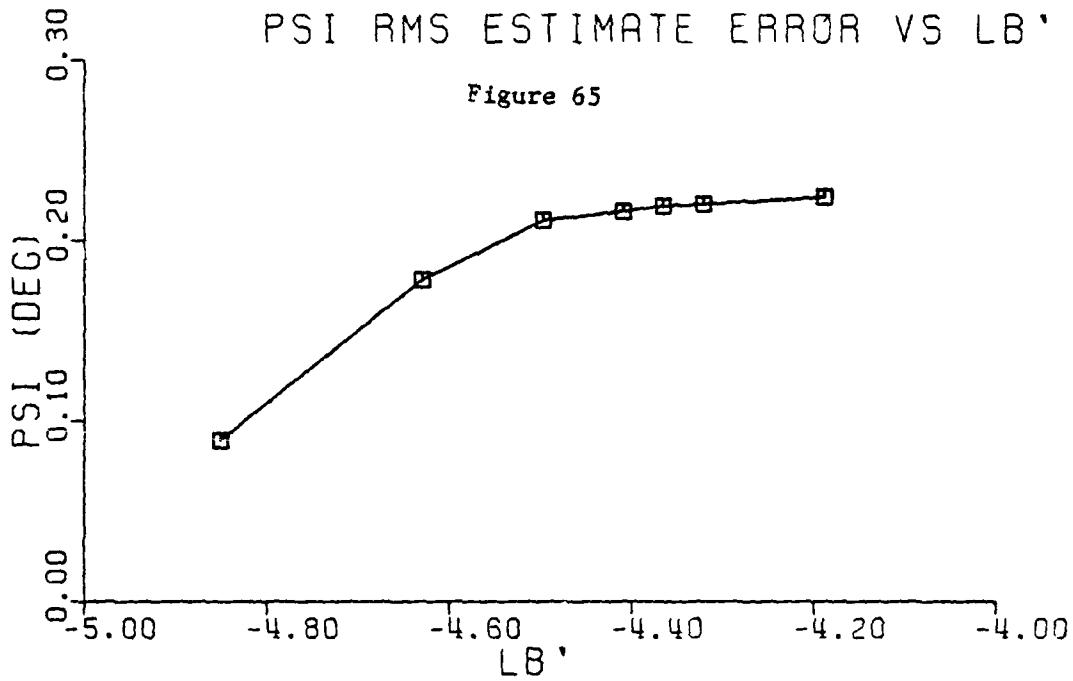

Figures 65 & 66. Sensitivity of $\bar{\psi}$ and $V\bar{\beta}_g$ rms estimate errors vs variation in L'_β stability derivative.

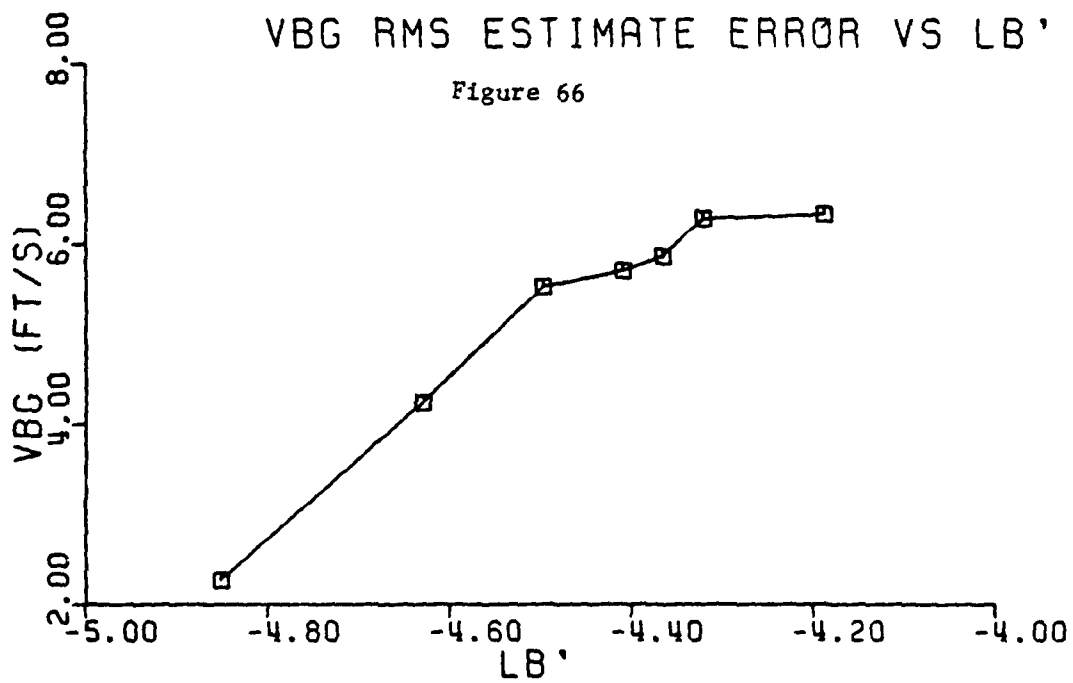

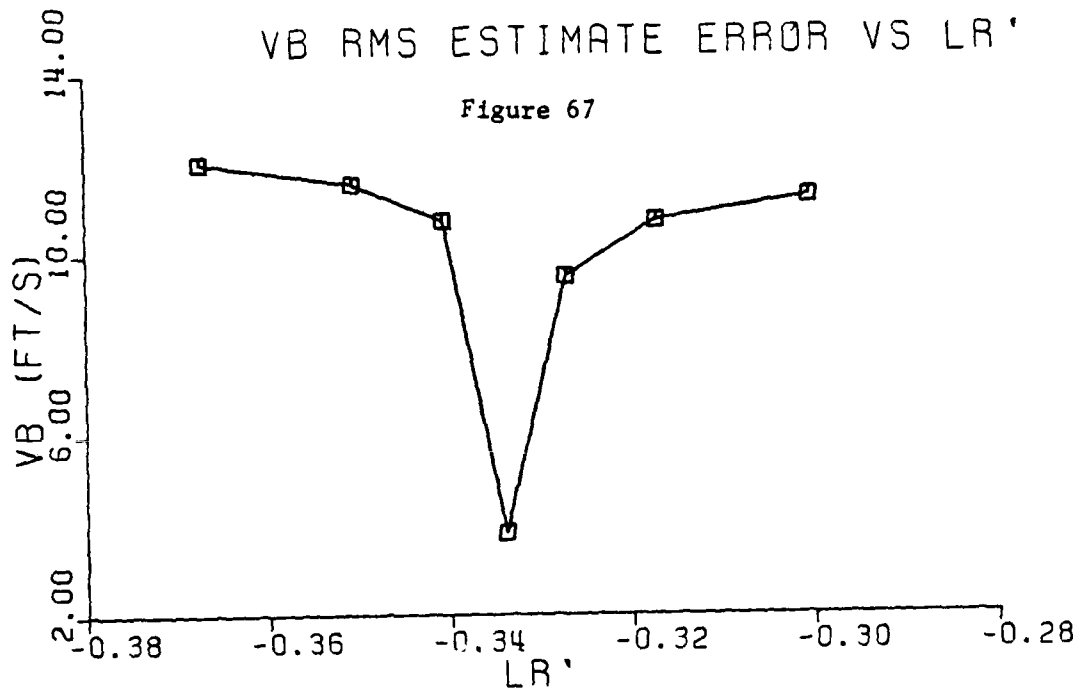

Figures 67 & 68. Sensitivity of \bar{V}_B and \bar{r} rms estimate errors vs variation of L'_r stability derivative.

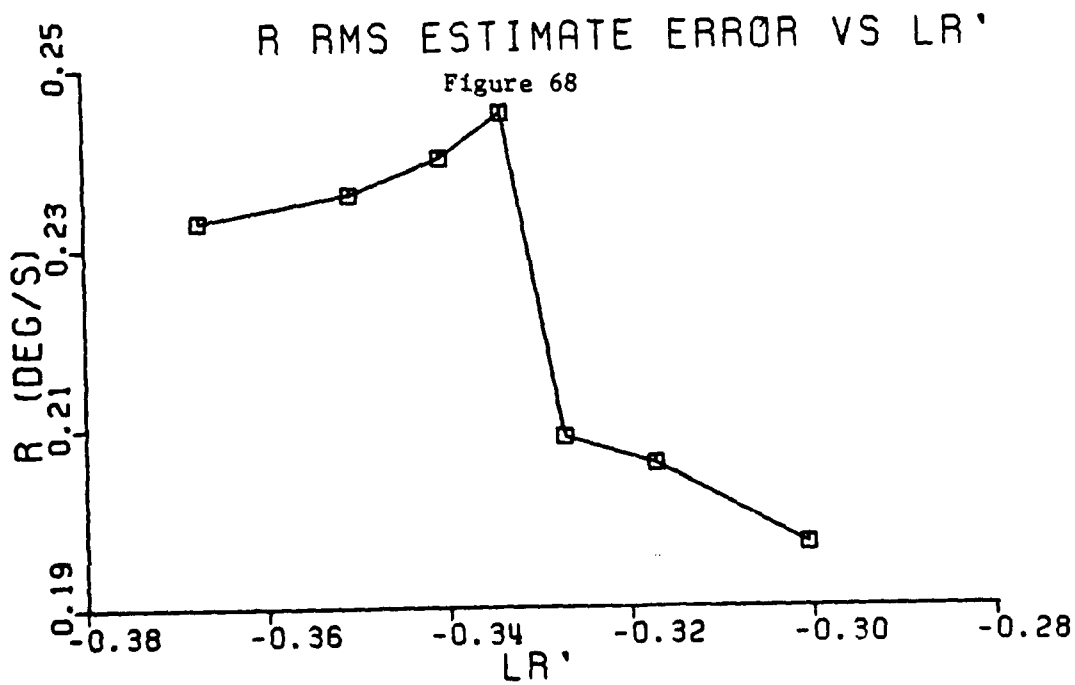

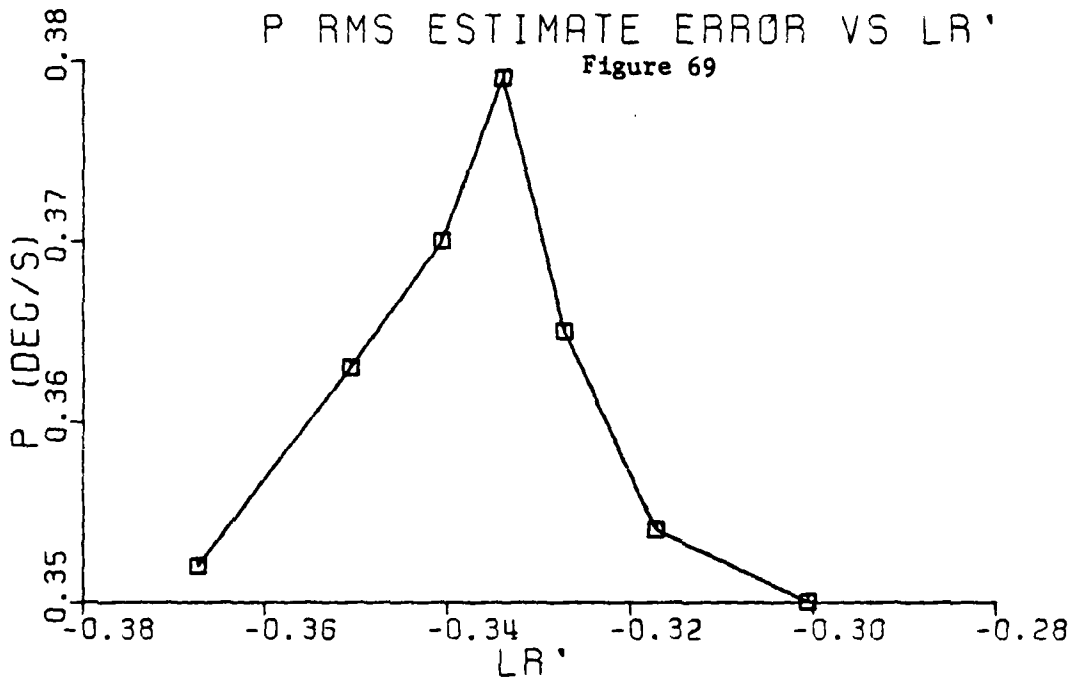

Figures 69 & 70. Sensitivity of \bar{p} and $\bar{\theta}$ rms estimate errors vs variation of L'_r stability derivative.

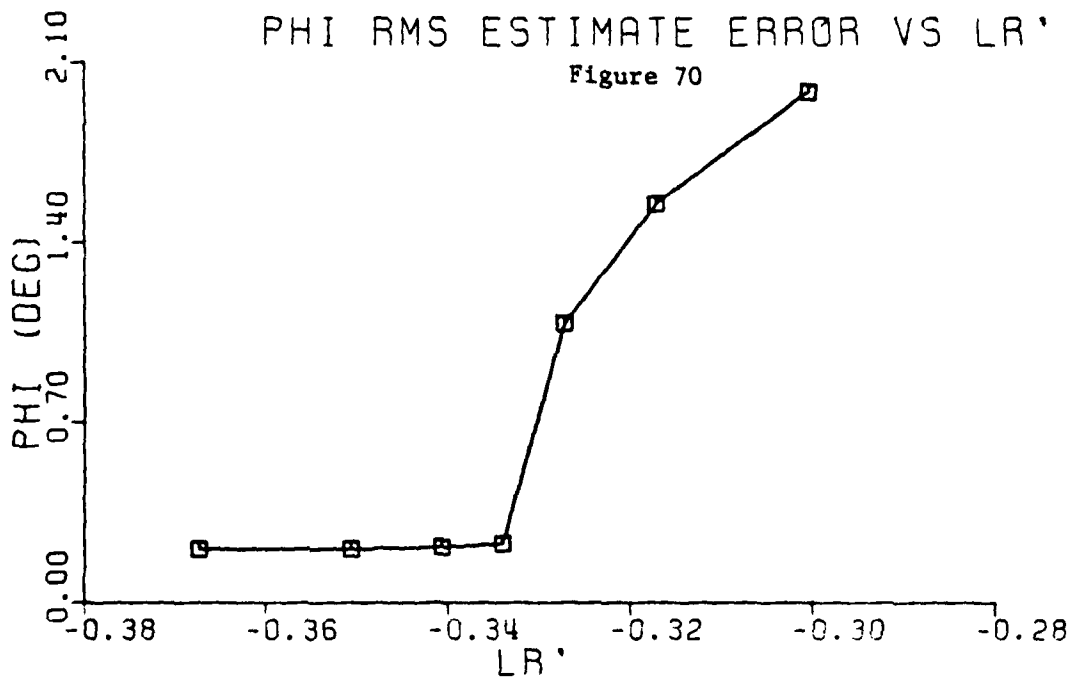

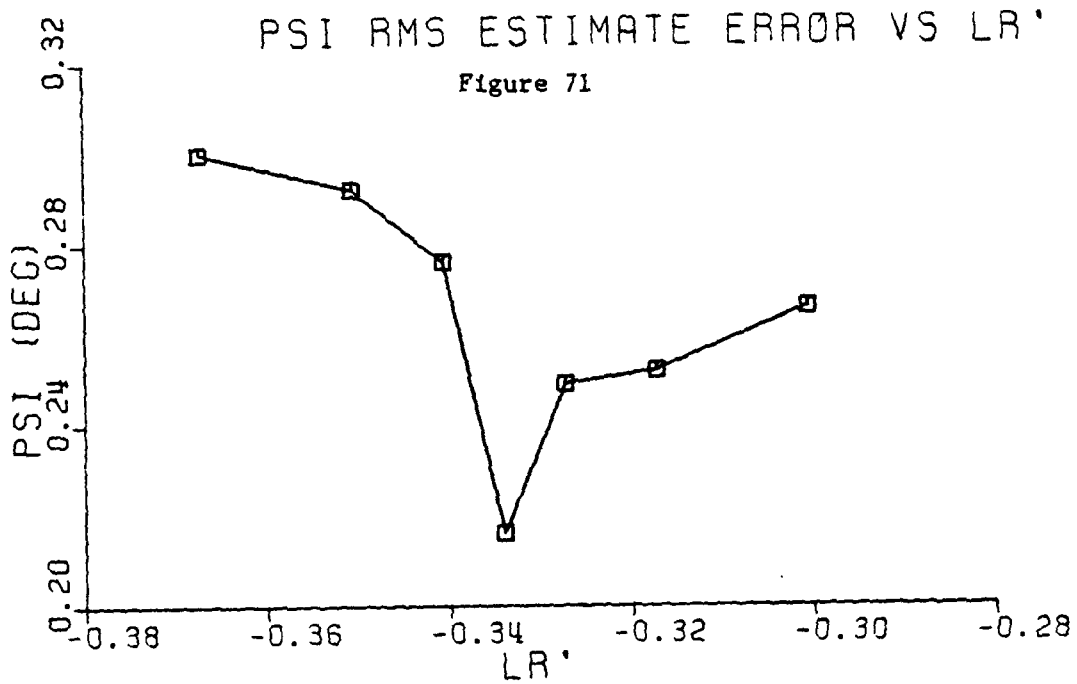

Figures 71 & 72. Sensitivity of $\bar{\psi}$ and \bar{V}_{Bg} rms estimate errors vs variation of L_r' stability derivative.

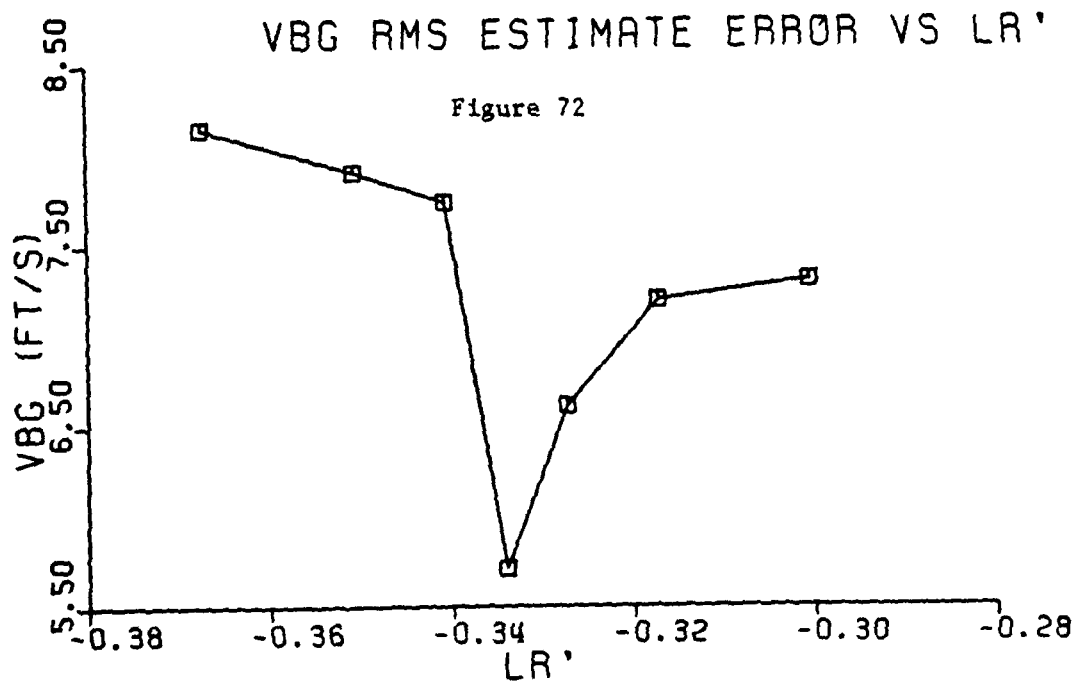

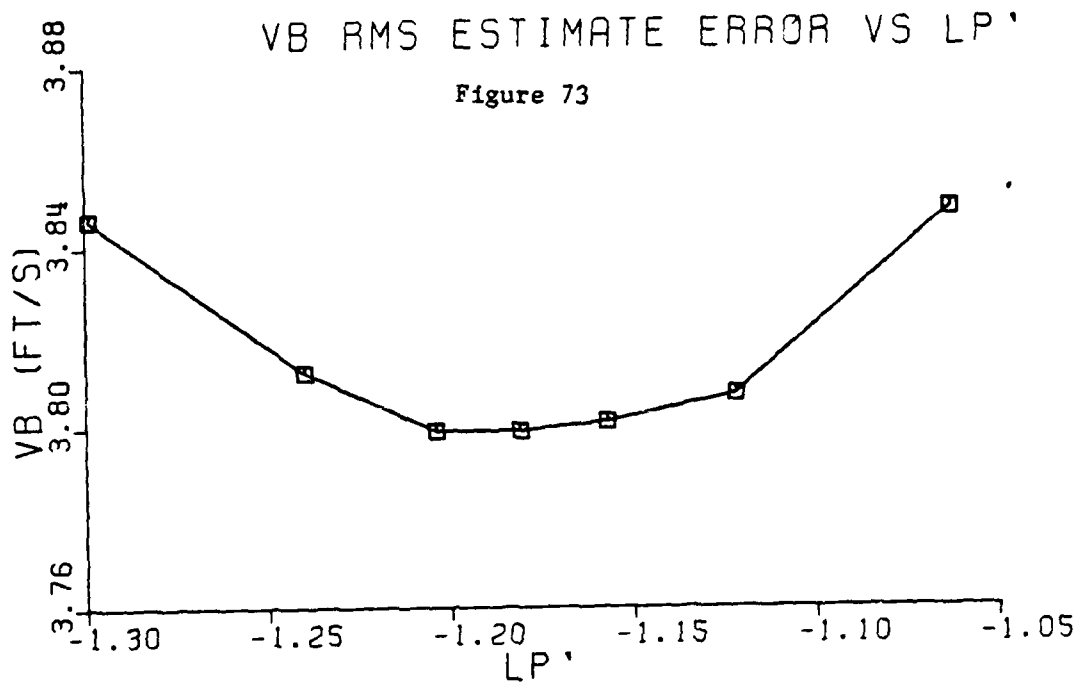

Figures 73 & 74. Sensitivity of \bar{V}_B and \bar{r} rms estimate errors vs variation in L_p' stability derivative.

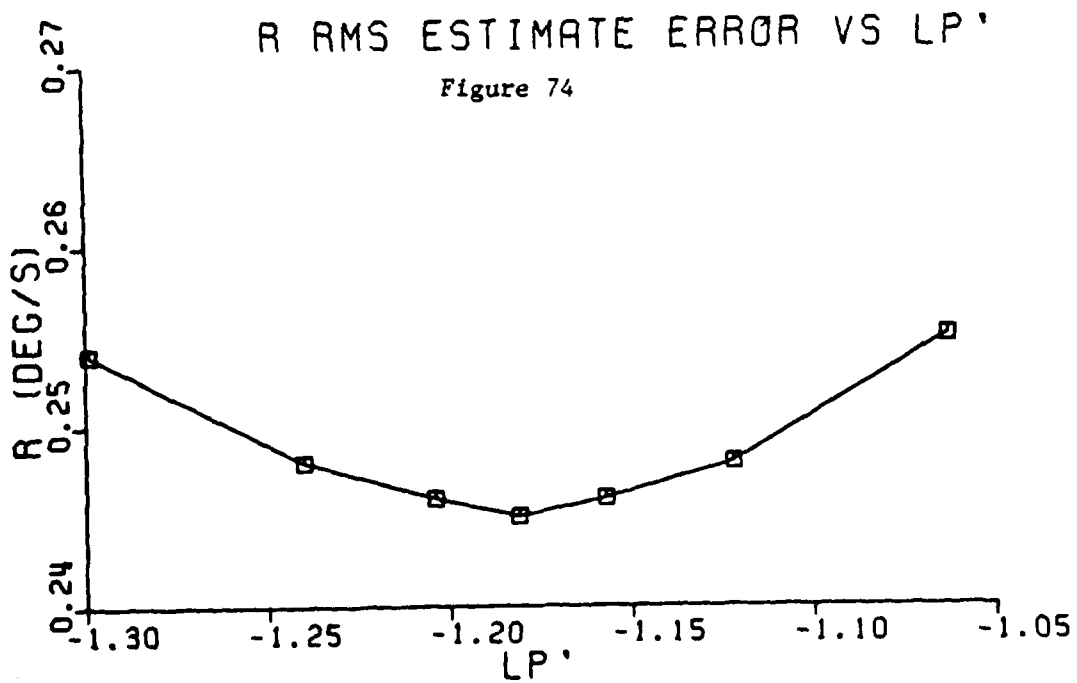

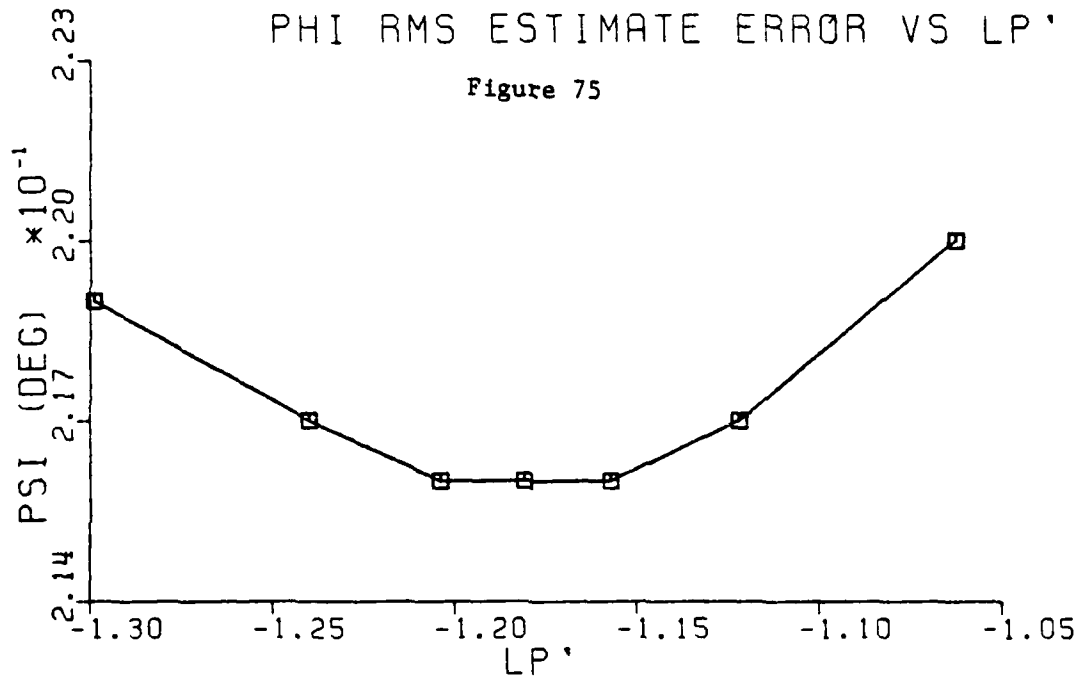

Figures 75 & 76. Sensitivity of $\bar{\theta}$ and \bar{V}_g rms estimate errors vs variation in L'_p stability derivative.

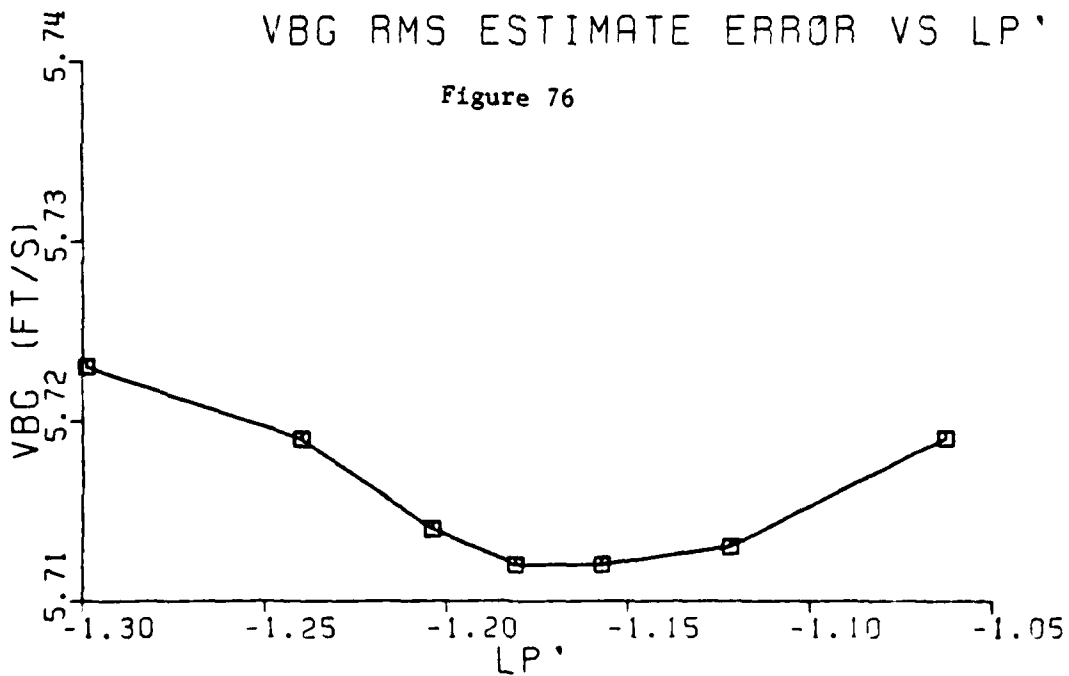

V. CONCLUSIONS AND RECOMMENDATIONS

A. CONCLUSIONS

Using steady-state Kalman Filters as observers in an inertial navigation system, the sensitivity of rms estimate errors to inaccuracies in the stability derivatives was studied. The conclusions reached at the end of this research are presented in two parts as they were analyzed.

1. Longitudinal Motion Estimator

a. Numerical variations in the dimensional derivatives; X_u , X_w and M_q do not show any important effect in the rms estimate errors. The value of these parameters as implemented in the filter can have large variations with respect to their nominal values (perhaps a tolerance of $\pm 20\%$).

b. Changes in the stability derivatives; Z_u , M_u and M_w are reflected with variation in almost all the rms estimate errors. In particular, large variations in \bar{u} rms estimate error can begin to be important in terms of accuracy in the radial position. These parameters can be implemented in the dynamics of the filter with some degree of tolerance with respect to their true value (for the case under analysis no more than $\pm 5\%$).

c. The most important effects are found with the variations of the stability derivatives; Z_w and M_w . Z_w gives the strongest alterations in all the rms estimate errors and

small changes ($\pm 2\%$ the tolerance in the case under study) in this parameter are unacceptable in the filter. For M_w the situation is quite similar and the value of this derivative is very important. In general, Z_w and M_w must be faithfully reproduced in the filter.

2. Lateral Motion Estimator

It is not possible to use the SKF as an observer under the particular configuration of the models given for lateral motion. The filter is stable but with a narrow margin of stability. The most minimum numerical variation (i.e., $\pm 1\%$) in the value of any stability derivative results in a failure of the filter due to divergence. This result complements the discussion given in Ref. [4]. Using a sub-optimal filter (with modified gains), the effect of the numerical variation in each of the stability derivatives are:

a. Numerical variations in the dimensional derivatives; Y_v , N_r' and L_p' do not cause important effects in any of the rms estimate errors. The reproduction of these parameters in the filter are not required to be too accurate (considering in this case a tolerance of $\pm 10\%$).

b. N_p' is a parameter that only accepts small variations in its value (in the problem discussed, 2% of tolerance) because it has strong effects in the estimation of $\bar{\delta}$ rms estimate error.

c. The stability derivative N'_β is one of the most important in terms of faithful reproduction in the dynamics of the filter. In general, it can be said that any numerical variation in its true value is not allowed.

d. Finally, L'_β and L'_r present the most dramatic situation, because a minimum change in its value is reflected with very large changes in the estimation of rms errors and it can result in divergence of the Kalman Filter. The lateral motion estimator design requires that these stability derivatives must be reproduced in the filter with the maximum of accuracy, otherwise, the result can be failure of the filter.

Of the two estimators used in the implementation of the INS, the lateral filter is more sensitive to variation in its parameter value. It should be remembered that the conclusions reached in this analysis apply specifically to the model being analyzed. Other models involving different missiles may indicate different sensitivities.

Nevertheless, it is felt that the conclusions presented in this thesis are of general validity.

B. SUGGESTIONS FOR FURTHER ANALYSIS

The most obvious extension of the work would be to test the estimators using the real data for a missile.

Further study could be to consider the same problem designing the estimators with a model that includes the addition of the estimation in position in order to analyze the problem

in terms of miss distance in radial position for a missile that at the end of the mid-course guidance phase must hit a "basket" (terminal guidance phase).

VI. SUMMARY

The great advantage of the analysis in the sensitivity of rms estimate errors to inaccuracies in the stability derivatives is that it points out clearly which derivatives are worthy of detailed accurate determination and which are not.

The following table summarizes the level of importance of each of the stability derivatives in the implementation of the steady-state Kalman Filters to be used as estimators in an INS.

	<u>DERIVATIVE</u>	<u>NI</u>	<u>SI</u>	<u>PI</u>
LONGITUDINAL MOTION ESTIMATION	Xu	X		
	Xw	X		
	Zu		X	
	Zw			X
	Mu		X	
	Mw			X
	Mq	X		
	M \dot{w}		X	
LATERAL MOTION ESTIMATION	Yv	X		
	N' _{β}			X
	N' _r	X		
	N' _p			X
	L' _{β}			X
	L' _r			X
L' _p	X			

NI = Not Important

SI = Secondary (Relative) Importance

PI = Primary Importance

APPENDIX A
LIST OF SYMBOLS

Regular Symbols

Definition

A	Modal transformation of F matrix
B	Modal transformation of Γ matrix
C	Modal transformation of H matrix
D	Dutch roll mode
E	Destabilization matrix
F	System dynamics matrix
f	Subscript for filter
F'	Destabilized matrix
g	Subscript for wind speed
H	Measurement matrix
H	Heading Mode
h	Altitude
INS	Inertial Navigation System
K	Kalman Filter gain matrix
L	Rolling moment (about X axis)
M	Pitching moment (about Y axis)
MDS	Modal destabilization
N	Yawing moment (about Z axis)
n	Non-white gaussian noise
P	Covariance propagation of the estimate error matrix
p	Perturbed roll rate
Q	Covariance matrix of w
q	Perturbed pitch rate
R	Covariance matrix of v
r	Perturbed yaw rate
S	Spiral mode
SKF	Steady-state Kalman Filter
T	Transformation matrix

Regular SymbolsDefinition

UNS	Undisturbed neutrally stable
u	Perturbed forward speed (along X axis)
v	Forward velocity
v	Perturbed side velocity
w	Driving white gaussian noise
w	Perturbed downward velocity
X	Reference axis
x	State vector of the system
\hat{x}	State estimate vector
\tilde{x}	Estimate error vector
Y	Reference axis
z	Measurement vector
Z	Reference axis

Greek SymbolsDefinition

ψ	Heading Angle
θ	Perturbed pitch attitude angle
ϕ	Perturbed bank (roll) angle
β	Sideslip angle
Γ	Driving noise matrix
σ	Eigenvalue constrain
σ	Standard deviation
ξ	Transformed state vector

APPENDIX B
AERODYNAMIC DATA AND PROBABILISTIC INFORMATION

$$v = 820 \text{ ft/s}$$

1. Longitudinal Model

a. Dimensional Derivatives

$$\begin{aligned} X_u &= -0.015 \quad 1/s \\ X_w &= 0.004 \quad 1/s \\ Z_u &= -0.074 \quad 1/s \\ Z_w &= -0.0806 \quad 1/s \\ M_u &= -0.0786 \quad 1/s\text{-ft} \\ M_w &= -0.0111 \quad 1/s\text{-ft} \\ M_q &= -0.924 \quad 1/s\text{-rad.} \\ M\dot{w} &= -0.00051 \quad 1/\text{ft} \end{aligned}$$

b. Disturbance Noise Standard Deviation

$$\begin{aligned} \sigma_u = \sigma_w &= 1.15 \quad 1/s \quad (10 \text{ ft/s})^2 \\ & \text{(7 ft/s rms gust with a 930-ft correlation} \\ & \text{distance).} \end{aligned}$$

c. Observation Noise Standard Deviation

$$\begin{aligned} \sigma_q &= 0.15 \text{ s} \quad (0.01 \text{ rad/s}) \\ \sigma_h &= 0.05 \text{ s} \quad (100 \text{ ft})^2 \end{aligned}$$

2. Lateral Models

a. Dimensional Derivatives

$$\begin{aligned} Y_v &= -0.0868 \quad 1/s \\ N_{\beta}^{\prime} &= 2.14 \quad 1/s^2 \\ N_r^{\prime} &= -0.228 \quad 1/s \\ N_p^{\prime} &= -0.0204 \quad 1/s \end{aligned}$$

$$L'_g = -4.41 \quad 1/s^2$$

$$L'_r = 0.034 \quad 1/s$$

$$L'_p = -1.181 \quad 1/s$$

b. Disturbance Noise Standard Deviation

$$\sigma = 1.63 \times 10^{-4} \quad 1/s \quad (7 \text{ ft/s rms gust with a } 930 \text{ ft correlation distance)}$$

c. Observation Noise Standard Deviation

$$\sigma_p = 1.5 \times 10^{-5} \quad s$$

$$\sigma_\psi = 1.5 \times 10^{-5} \quad 1/s$$

COMPUTER OUTPUT

Table 1. rms estimate errors for longitudinal motion estimator with variation in X_u derivative.

X_u	\bar{u} ft/s	\bar{w} ft/s	\bar{q} deg/s	$\bar{\theta}$ deg	\bar{h} ft	\bar{u}_g ft/s	\bar{w}_g ft/s
-0.018	2.096	5.102	0.416	0.317	8.248	4.776	5.701
-0.0165	2.094	5.102	0.416	0.317	8.246	4.776	5.701
-0.01575	2.091	5.102	0.416	0.317	8.240	4.776	5.701
-0.015 *	2.090	5.102	0.416	0.317	8.245	4.776	5.701
-0.01425	2.088	5.103	0.416	0.317	8.260	4.775	5.701
-0.0135	2.089	5.103	0.416	0.317	8.280	4.775	5.701
-0.012	2.092	5.103	0.416	0.317	8.340	4.775	5.701

Table 2. rms estimate errors for longitudinal motion estimator with variation in X_w derivative.

X_w	\bar{u} ft/s	\bar{w} ft/s	\bar{q} deg/s	$\bar{\theta}$ deg	\bar{h} ft	\bar{u}_g ft/s	\bar{w}_g ft/s
0.0048	2.070	5.102	0.416	0.317	8.319	4.776	5.701
0.0044	2.080	5.102	0.416	0.317	8.282	4.776	5.701
0.0042	2.086	5.102	0.416	0.317	8.257	4.776	5.701
0.004 *	2.090	5.102	0.416	0.317	8.245	4.776	5.701
0.0038	2.100	5.102	0.416	0.317	8.223	4.776	5.701
0.0036	2.103	5.102	0.416	0.316	8.215	4.776	5.701
0.0032	2.110	5.101	0.416	0.316	8.170	4.776	5.701

Table 3. rms estimate errors for longitudinal motion estimator with variation in Zu derivative.

Zu	\bar{u} ft/s	\bar{w} ft/s	\bar{q} deg/s	$\bar{\theta}$ deg	\bar{h} ft	\bar{u}_g ft/s	\bar{w}_g ft/s
-0.0888	1.885	5.106	0.416	0.322	9.310	4.776	5.707
-0.0814	1.974	5.104	0.416	0.319	8.808	4.775	5.703
-0.0777	2.026	5.194	0.416	0.318	8.579	4.775	5.702
-0.0740 *	2.090	5.102	0.416	0.317	8.245	4.776	5.701
-0.0703	2.122	5.100	0.416	0.315	7.800	4.777	5.700
-0.0666	2.270	5.095	0.416	0.313	7.101	4.777	5.697
-0.0592	2.32	5.094	0.416	0.311	7.000	4.778	5.695

Table 4. rms estimate errors for longitudinal motion estimator with variation in Zw derivative.

Zw	\bar{u} ft/s	\bar{w} ft/s	\bar{q} deg/s	$\bar{\theta}$ deg	\bar{h} ft	\bar{u}_g ft/s	\bar{w}_g ft/s
-0.9612	30.08	6.172	0.486	0.440	17.97	4.778	7.138
-0.8866	11.80	5.810	0.428	0.415	33.50	4.785	5.947
-0.8463	5/345	5/259	0.421	0.400	22.776	4.779	5.737
-0.806 *	2.090	5.102	0.416	0.317	8.245	4.776	5.701
-0.7657	2.668	5.032	0.412	0.219	16.903	4.772	5.710
-0.7256	3.188	5.035	0.407	0.200	21.026	4.769	5.746
-0.665	3.260	5.065	0.406	0.185	23.000	4.767	5.794

Table 5. rms estimate errors for longitudinal motion estimator with variation in M_u derivative.

\bar{M}_u	\bar{u} ft/s	\bar{w} ft/s	\bar{q} deg/s	$\bar{\theta}$ deg	\bar{h} ft	\bar{u}_g ft/s	\bar{w}_g ft/s
-0.000943	2.234	5.061	0.416	0.305	6.230	4.775	5.689
-0.000865	2.115	5.089	0.416	0.310	6.640	4.775	5.695
-0.000825	2.104	5.094	0.416	0.314	7.531	4.776	5.698
-0.000786*	2.090	5.102	0.416	0.317	8.245	4.776	5.701
-0.000747	1.993	5.105	0.416	0.318	8.595	4.777	5.703
-0.000707	1.866	5.108	0.416	0.319	8.832	4.779	5.705
-0.000629	1.566	5.111	0.416	0.322	9.178	4.783	5.708

Table 6. rms estimate errors for longitudinal motion estimator with variation in M_w derivative.

M_w	\bar{u} ft/s	\bar{w} ft/s	\bar{q} deg/s	$\bar{\theta}$ deg	\bar{h} ft	\bar{u}_g ft/s	\bar{w}_g ft/s
-0.01165	18.43	8.350	0.502	0.455	29.870	4.778	5.695
-0.0113	5.163	5.142	0.433	0.373	17.790	4.778	5.694
-0.0112	3.110	5.113	0.418	0.321	10.427	4.777	5.699
-0.0111*	2.090	5.102	0.416	0.317	8.245	4.776	5.701
-0.0109	5.206	5.018	0.419	0.325	16.650	4.776	5.700
-0.01055	13.652	5.342	0.447	0.430	12.204	4.776	5.918
-0.00999	19.13	18.95	0.475	0.704	68.98	4.756	6.102

Table 7. rms estimate errors for longitudinal motion estimator with variation in M_q derivative.

M_q	\bar{u} ft/s	\bar{w} ft/s	\bar{q} deg/s	$\bar{\theta}$ deg	\bar{h} ft	\bar{u}_g ft/s	\bar{w}_g ft/s
-1.109	2.091	5.102	0.416	0.316	8.230	4.776	5.701
-1.016	2.091	5.102	0.416	0.316	8.234	4.776	5.701
-0.970	2.091	5.102	0.416	0.317	8.236	4.776	5.701
-0.924*	2.090	5.102	0.416	0.317	8.245	4.776	5.701
-0.880	2.090	5.102	0.416	0.316	8.244	4.776	5.701
-0.832	2.089	5.102	0.416	0.316	8.236	4.776	5.701
-0.7392	2.089	5.102	0.416	0.316	8.232	4.776	5.701

Table 8. rms estimate errors for longitudinal motion estimator with variation in $M_{\dot{w}}$ derivative.

$M_{\dot{w}}$	\bar{u} ft/s	\bar{w} ft/s	\bar{q} deg/s	$\bar{\theta}$ deg	\bar{h} ft	\bar{u}_g ft/s	\bar{w}_g ft/s
-0.00061	2.610	5.053	0.417	0.273	10.665	4.775	5.688
-0.00056	2.476	5.089	0.417	0.295	6.301	4.776	5.703
-0.00053	2.398	5.091	0.417	0.304	4.150	4.776	5.698
-0.00051*	2.090	5.102	0.416	0.317	8.245	4.776	5.701
-0.00049	2.491	5.108	0.416	0.322	9.757	4.776	5.702
-0.00046	2.976	5.118	0.415	0.332	12.067	4.776	5.703
-0.00041	3.570	5.124	0.415	0.340	13.536	4.776	5.703

Table 9. rms estimate errors for lateral motion estimator with variation in Y derivate.

Y_v	\bar{v}_β ft/s	\bar{r} deg/s	\bar{p} deg/s	$\bar{\theta}$ deg	$\bar{\psi}$ deg	$\bar{v}_{\beta g}$ ft/s
-.10416	3.914	0.246	0.380	0.236	0.216	5.743
-.09548	3.856	0.246	0.379	0.231	0.216	5.728
-.09110	3.827	0.245	0.379	0.228	0.216	5.719
-.0868 *	3.799	0.245	0.379	0.226	0.216	5.719
-.08246	3.769	0.245	0.378	0.223	0.215	5.702
-.07812	3.741	0.245	0.378	0.220	0.215	5.694
-.06944	3.678	0.245	0.377	0.214	0.215	5.677

Table 10. rms estimate errors for lateral motion estimator with variation in N'_β derivative.

N'_β	\bar{v}_β ft/s	\bar{r} deg/s	\bar{p} deg/s	$\bar{\theta}$ deg	$\bar{\psi}$ deg	$\bar{v}_{\beta g}$ ft/s
2.354	6.889	0.280	0.391	0.649	0.233	7.719
2.247	5.129	0.266	0.384	0.501	0.230	6.220
2.1828	4.717	0.253	0.383	0.404	0.223	6.052
2.14 *	3.799	0.245	0.379	0.226	0.216	5.712
2.0972	4.125	0.237	0.371	0.325	0.217	5.938
2.033	4.956	0.224	0.353	0.655	0.218	6.543
1.926	8.781	0.201	0.299	1.101	0.220	8.240

Table 11. rms estimate errors for lateral motion estimator with variation in N'_r derivative.

N'_r	\bar{V}_β ft/s	\bar{r} deg/s	\bar{p} deg/s	$\bar{\theta}$ deg	$\bar{\psi}$ deg	$\bar{V}_{\beta g}$ ft/s
-0.2736	3.790	0.248	0.380	0.225	0.217	5.704
-0.2508	3.791	0.246	0.379	0.225	0.216	5.706
-0.2394	3.794	0.246	0.379	0.225	0.216	5.710
-0.228 *	3.799	0.245	0.379	0.226	0.216	5.712
-0.2166	3.805	0.245	0.379	0.226	0.216	5.714
-0.2052	3.815	0.246	0.379	0.228	0.216	5.719
-0.1824	3.834	0.248	0.379	0.231	0.216	5.727

Table 12. rms estimate errors for lateral motion estimator with variation in N'_p derivative.

N'_p	\bar{V}_β ft/s	\bar{r} deg/s	\bar{p} deg/s	$\bar{\theta}$ deg	$\bar{\psi}$ deg	$\bar{V}_{\beta g}$ ft/s
-0.02448	4.121	0.247	0.380	0.318	0.218	5.826
-0.02244	3.980	0.246	0.380	0.277	0.217	5.768
-0.02142	3.889	0.246	0.379	0.253	0.216	5.742
-0.0204 *	3.799	0.245	0.379	0.226	0.216	5.712
-0.01938	3.719	0.245	0.379	0.198	0.216	5.745
-0.01836	3.708	0.246	0.379	0.183	0.216	5.813
-0.01632	3.695	0.248	0.382	0.173	0.217	6.029

Table 13. rms estimate errors for lateral motion estimator with variation in L_{β} .

L_{β}	\bar{v}_{β} ft/s	\bar{r} deg/s	\bar{p} deg/s	$\bar{\theta}$ deg	$\bar{\psi}$ deg	\bar{v}_{β_g} ft/s
-4.8510	7.498	0.120	0.338	0.885	0.089	2.266
-4.6305	5.621	0.205	0.360	0.539	0.178	4.244
-4.4982	4.642	0.240	0.375	0.236	0.211	5.529
-4.41 *	3.799	0.245	0.379	0.226	0.216	5.712
-4.3659	4.268	0.249	0.382	0.319	0.219	5.875
-4.3218	4.640	0.250	0.390	0.402	0.220	6.295
-4.1895	5.246	0.253	0.393	0.492	0.224	6.238

Table 14. rms estimate errors for lateral motion estimator with variation in L_r' .

L_r'	\bar{v}_{β} ft/s	\bar{r} deg/s	\bar{p} deg/s	$\bar{\theta}$ deg	$\bar{\psi}$ deg	\bar{v}_{β_g} ft/s
-0.3674	12.030	0.233	0.352	0.205	0.300	8.149
-0.3507	11.538	0.236	0.363	0.208	0.292	7.910
-0.3407	10.712	0.240	0.370	0.213	0.276	7.746
-0.334 *	3.799	0.245	0.379	0.226	0.216	5.712
-0.3273	9.476	0.209	0.365	1.089	0.249	6.613
-0.3173	10.712	0.206	0.354	1.551	0.252	7.198
-0.3006	11.248	0.197	0.350	1.986	0.266	7.309

Table 15. rms estimate errors for lateral motion estimator with variation in L'_p .

L'_p	\bar{v}_β ft/s	\bar{r} deg/s	\bar{p} deg/s	$\bar{\theta}$ deg	$\bar{\psi}$ deg	\bar{v}_{β_g} ft/s
-1.299	3.846	0.254	0.380	0.228	0.219	5.723
-1.240	3.812	0.248	0.379	0.227	0.217	5.719
-1.204	3.799	0.246	0.379	0.226	0.216	5.714
-1.181 *	3.799	0.245	0.379	0.226	0.216	5.712
-1.1573	3.801	0.246	0.379	0.226	0.216	5.712
-1.122	3.807	0.248	0.379	0.226	0.217	5.713
-1.063	3.848	0.255	0.379	0.227	0.220	5.719

CC

SENSITIVITY COVARIANCE PROGRAM

THIS PROGRAM IS USED TO SOLVE THE ERROR SENSITIVITY EQUATIONS WHEN THERE IS AN INCORRECT IMPLEMENTATION OF DYNAMICS IN THE DESIGN OF THE KALMAN FILTER. THE EQUATIONS BECOME

PDOT=(F*-K*H)P+P(F*-K*H)T+DFV+VTDFT+GQGT+K*RK*T
VDOT=FV+V(F*-K*H)T+UDFT-GQGT
UDOT=FU+UFT+GQGT

THE PRINCIPAL PROGRAM INPUTS ARE THE FOLLOWING COLLECTION OF SYSTEM AND FILTER MATRICES

- PO THE INITIAL COVARIANCE MATRIX(NXN)
- F THE TRUTH MODEL DYNAMICS MATRIX(NXN)
- F* THE FILTER MODEL DYNAMICS MATRIX(NXN)
- H THE TRUTH MODEL MEASUREMENT MATRIX(LXN), WHERE L IS THE MEASUREMENT VECTOR DIMENSION
- GQGT THE INPUT NOISE COVARIANCE MATRIX(NX)
- R THE MEASUREMENT NOISE COVARIANCE MATRIX(LXL)
- K* FILTER GAIN(NXL)

CC

THIS PROGRAM HAS BEEN DEVELOPED USING THE IMSL LIBRARY AVAILABLE IN THE COMPUTER CENTER OF THE NAVAL POSTGRADUATE SCHOOL

```

IMPLICIT REAL*8 (A-H,O-Z)
COMMON F(7,7),FS(7,7),GQGT(7),AK(7,2),R(2,2),
*AKRKT(7,7),DF(7,7),FT(7,7),FSMKHT(7,7),DFT(7,7),
*FSMKH(7,7),H(2,7)
COMMON/KTR/N,NS,NPD
DIMENSION PFULL(7,7),PSQR(7)
DIMENSION DDT(7)
DIMENSION U(28),V(7,7),P(28),UD(28),VD(7,7),
*VAR(105),DRV(105),C(24),WK(105,9),PD(28)
DIMENSION Tmpl(7,7),TMP2(7,7),TMP3(7,7)
EQUIVALENCE (U(1),VAR(1)),(V(1,1),VAR(29)),(P(1),
*VAR(78)),(UD(1),DRV(1)),(VD(1,1),DRV(29)),(PD(1),
*DRV(78))

```

N=ORDER OF THE SYSTEM MODEL
NP=NUMBER OF POINTS
NPD=CONTROL OF INITIAL DIAGNOSTIC OUTPUT
DT=TIME INTERVAL
EXTERNAL FUN
CALL UGETIO(3,5,6)

THE FOLLOWING SECTION READS THE SPECIFIED INPUT MATRICES, F, F*, GQGT, K*H AND R

```

98 READ(5,98)N,NP,NPD,DT
98 FORMAT(3I5,F10.5)
WRITE(6,97)N,NP,NPD,DT
97 FORMAT('1',3I5,1X,G18.10)

```

AD-A096 393

NAVAL POSTGRADUATE SCHOOL MONTEREY CA
SENSITIVITY OF THE STEADY-STATE KALMAN FILTERS TO STABILITY DER--ETC(U)
SEP 80 J A MATALLANA R.

F/6 17/7

UNCLASSIFIED

NL

2 of 2

NO. 1
TYPE 385



END

DATE

FILMED

4-81

DTIC

```

NS=N*(N+1)/2
NI=NS+N**2+1
NV=2*NS+N**2
99 FORMAT(8F10.5)
C
DO 1 I=1,N
1 READ(5,99) (F(I,J),J=1,N)
CALL USWFM('F',1,F,7,N,N,1)
C
DO 2 I=1,N
2 READ(5,99) (FS(I,J),J=1,N)
CALL USWFM('FS',2,FS,7,N,N,1)
READ(5,99) (GQGT(I),I=1,N)
CALL USWFM('GQGT',4,GQGT,N,1,1)
C
DO 3 I=1,N
3 READ(5,99) (AK(I,J),J=1,2)
CALL USWFM('K',1,AK,7,N,2,1)
C
DO 4 I=1,2
4 READ(5,99) (H(I,J),J=1,N)
CALL USWFM('H',1,H,2,2,N,1)
C
DO 5 I=1,2
5 READ(5,99) (R(I,J),J=1,2)
CALL USWFM('R',1,R,2,2,2,1)
C
DO 6 I=1,105
6 VAR(I)=0.
DO 7 I=1,N
DO 7 J=1,N
C
7 DF(I,J)=FS(I,J)-F(I,J)
CALL USWFM('DEL F',5,DF,7,N,N,1)
CALL VMULFF(AK,2,N,2,2,7,2,TMP1,7,IER)
CALL VMULFP(TMP1,AK,N,2,N,7,7,AKRKT,7,IER)
CALL USWFM('KRKT',4,AKRKT,7,N,N,1)
C
C
C
CALCULATE THE DIFFERENCE BETWEEN THE DYNAMICS
IMPLEMENTED IN THE FILTER AND THE PLANT, DF=F*-F
C
DO 20 I=1,N
DO 20 J=1,N
DFT(I,J)=DF(I,J)
20 FT(I,J)=F(I,J)
CALL VTRANX(DFT,N,N,7)
CALL USWFM('DEL FT',6,DFT,7,N,N,1)
CALL VTRANX(FT,N,N,7)
CALL USWFM('FT',2,FT,7,N,N,1)
CALL VMULFF(AK,H,N,2,N,7,2,TMP1,7,IER)
C
DO 21 I=1,7
DO 21 J=1,7
FSMKH(I,J)=FS(I,J)-TMP1(I,J)
21 FSMKHT(I,J)=FSMKH(I,J)
CALL USWFM('FS-KH',5,FSMKH,7,N,N,1)
CALL VTRANX(FSMKHT,N,N,7)
CALL USWFM('(FS-KH)T',8,FSMKHT,7,N,N,1)
T=0.
TOL=1.0-5
IND=1
L=0
IF(N.EQ.7) GO TO 11
C
DO 31 I=1,NS
L=L+1
31 VAR(L)=U(I)

```

```

C      DO 32 I=1,N
      DO 32 J=1,N
      L=L+1
C     32 VAR(L)=V(I,J)
      DO 33 I=1,N
      L=L+1
C     33 VAR(L)=P(I)
C     11 DO 10 K=1,NP
      TEND=FINAL TIME
      TEND=K*DT
      DVERK SUBROUTINE FINDS THE SOLUTION OF THE SYSTEM OF
      DIFFERENTIAL EQUATIONS
      CALL DVERK(NV,FUN,T,VAR,TEND,TOL,IND,C,105,WK,IER)
      IF(IND.LE.0.OR.IER.NE.0)STOP
      CALL VCVTSF(VAR(N1),N,PFULL,7)
      CALCULATE AND PRINT THE RMS ESTIMATE ERRORS
      DO 30 I=1,N
C     30 PSQR(I)=DSQRT(PFULL(I,I))
      WRITE(6,90)T,(PSQR(I),I=1,N)
C     90 FORMAT('0T=',F10.5,' PSR=',7315.7)
      IF DESIRED PRINT THE COVARIANCE MATRICES,P,U AND V
      CALL USWSM('U',1,U,N,2)
      CALL USWFM('V',1,VAR(NS+1),7,N,N,2)
      CALL USWSM('P',1,VAR(N1),N,2)
C     10 CONTINUE
      STOP
      END

```

```
SUBROUTINE VTRANS(A,N,NC,IA)
IMPLICIT REAL*8 (A-H,O-Z)
DIMENSION A(IA,IA),B(7,7)
C
DO 1 I=1,N
DO 1 J=1,N
1 B(I,J)=A(J,I)
C
DO 2 I=1,N
DO 2 J=1,N
2 A(I,J)=B(I,J)
RETURN
END
```

```

SUBROUTINE FUN(V,T,VAR,DRV)
C
C
C
FCN SUBROUTINE IS USED FOR EVALUATING FUNCTIONS(INPUT)
C
IMPLICIT REAL*8 (A-H,O-Z)
COMMON F(7,7),FS(7,7),GQGT(7),AK(7,2),R(2,2),
*AKRKT(7,7),DF(7,7),FT(7,7),FSMKHT(7,7),DFT(7,7),
*FSMKH(7,7),H(2,7)
COMMON/KTR/N,NS,NPD
DIMENSION U(28),V(7,7),P(28),UD(28),VD(7,7),
*VAR(105),DRV(105),C(24),WK(105,9),PD(28)
DIMENSION TMP1(7,7),TMP2(7,7),TMP3(7,7)
C
L=0
DO 1 I=1,NS
L=L+1
1 U(I)=VAR(L)
C
DO 2 I=1,N
DO 2 J=1,N
L=L+1
2 V(I,J)=VAR(L)
C
DO 3 I=1,NS
L=L+1
3 P(I)=VAR(L)
IF(T.EQ.0)KT=NPD
KT=KT+1
IF (KT.GE.5) GO TO 15
WRITE(6,99) T
99 FORMAT('OT=',D25.15)
CALL USWSM('U',1,U,N,2)
CALL USWFM('V',1,V,7,N,N,2)
CALL USWSM('P',1,P,N,2)
15 CALL VMULFS(F,U,N,N,7,TMP1,7)
IF(KT.LT.5) CALL USWFM('FU',2,TMP1,7,N,N,2)
CALL VMULSF(U,N,FT,N,7,TMP2,7)
IF(KT.LT.5) CALL USWFM('UFT',3,TMP2,7,N,N,2)
C
DO 5 I=1,N
DO 4 J=1,N
4 TMP1(I,J)=TMP1(I,J)+TMP2(I,J)
5 TMP1(I,I)=TMP1(I,I)+GQGT(I)
CALL VCVTFS(TMP1,N,7,UD)
IF(KT.LT.5) CALL USWSM('UDOT',4,UD,N,2)
CALL VMULFF(F,V,N,N,N,7,7,TMP1,7,IER)
IF(KT.LT.5) CALL USWFM('FV',2,TMP1,7,N,N,2)
CALL VMULFF(V,FSMKHT,N,N,N,7,7,TMP2,7,IER)
IF(KT.LT.5) CALL USWFM('V*(FS-KH)T',10,TMP2,7,N,N,2)
CALL VMULSF(U,N,DFT,N,7,TMP3,7)
IF(KT.LT.5) CALL USWFM('U*DFT',5,TMP3,7,N,N,2)
C
DO 7 I=1,N
DO 6 J=1,N
6 VD(I,J)=TMP1(I,J)+TMP2(I,J)+TMP3(I,J)
7 VJ(I,I)=VD(I,I)-GQGT(I)
IF(KT.LT.5) CALL USWFM('VDOT',4,VD,7,N,N,2)
CALL VMULFS(FSMKH,P,N,N,7,TMP1,7)
IF(KT.LT.5) CALL USWFM('P*(FS-KH)P',8,TMP1,7,N,N,2)
CALL VMULSF(P,N,FSMKHT,N,7,TMP2,7)
IF(KT.LT.5) CALL USWFM('P*(FS-KH)T',9,TMP2,7,N,N,2)
CALL VMULFF(DF,V,N,N,N,7,7,TMP3,7,IER)
IF(KT.LT.5) CALL USWFM('DF*V',4,TMP3,7,N,N,2)
C
DO 8 I=1,N

```

```

DO 8 J=1,N
8 TMP1(I,J)=TMP1(I,J)+TMP2(I,J)+TMP3(I,J)
CALL VMULFM(V,DF,N,N,N,7,7,TMP3,7,IER)
IF(KT.LT.5) CALL USWFM('VT*DF',5,TMP3,7,N,N,2)
C
DO 10 I=1,N
DO 9 J=1,N
9 TMP3(I,J)=TMP1(I,J)+TMP3(I,J)+AKRKT(I,J)
10 TMP3(I,I)=TMP3(I,I)+GQGT(I)
IF(KT.LT.5) CALL USWFM('PDOT',4,TMP3,7,N,N,2)
CALL VCVTFS(TMP3,N,7,PD)
IF(KT.LT.5) CALL USWFM('PDOT(SYM)',9,PD,N,1,2)
L=0
C
DO 11 I=1,NS
L=L+1
11 DRV(L)=UD(I)
C
DO 12 I=1,N
DO 12 J=1,N
L=L+1
12 DRV(L)=VD(I,J)
C
DO 13 I=1,NS
L=L+1
13 DRV(L)=PD(I)
IF(KT.LT.5) CALL USWFM('DRV',3,DRV,NV,1,2)
RETURN
END

```

LIST OF REFERENCES

1. Gelb, A. and others, Applied Optimal Estimation, M.I.T. Press, 1974.
2. Maybeck, P. S., Stochastic Models, Estimation and Control, Vol. 1, Academic Press, 1979.
3. Franklin, G. F. and Powell, J. D., Digital Control of Dynamic Systems, Addison-Wesley, 1980.
4. Bryson, A. E., Jr., Kalman Filter Divergence and Aircraft Motion Estimators, Vol. 1, No. 1, AIAA Journal, January 1978.
5. Anderson, B. D. O., and Moore, J. B., Linear System Optimization with Prescribed Degree of Stability, Proc. IEE, Vol. 116, No. 12, December 1969.
6. Garnell, P. and East, D. J., Guided Weapon Control Systems, 1st ed., Pergamon Press, 1977.
7. Collins, D. J., Missiles, Navigation and Avionic Systems, Class Notes, Naval Postgraduate School, April 1980.
8. McRuer, D., and others, Aircraft Dynamics and Automatic Control, Princeton University Press, 1973.
9. Holley, W. E., and Bryson, A. E., Jr., Wind Modeling and Lateral Control for Automatic Landings, Vol. 14, No. 2, AIAA Journal, February 1977.
10. Sandell, N. R., and Athans, M., Modern Control Theory, Manual of Fortran Computer, Subroutines for Linear, Quadratic, Gaussian Designs, Massachusetts Institute of Technology.
11. Walker, R., OPTSYS 4 at SCIP Computer Program, Stanford University, Aero/Astro Dept., December 1979.

INITIAL DISTRIBUTION LIST

	No. Copies
1. Defense Technical Information Center Cameron Station Alexandria, Virginia 22314	2
2. Library, Code 0142 Naval Postgraduate School Monterey, California 93940	2
3. Department Chairman, Code 62 Department of Electrical Engineering Naval Postgraduate School Monterey, California 93940	1
4. Professor D. J. Collins, Code 67Co Department of Aeronautics Naval Postgraduate School Monterey, California 93940	3
5. Professor A. Gerba, Jr., Code 626Z Department of Electrical Engineering Naval Postgraduate School Monterey, California 93940	1
6. Sr. Almirante Comandante Armada Nacional Ministerio de Defensa C.A.N. Bogota, Colombia S.A.	1
7. Sr. Vicealmirante Segundo Comandante Armada Nacional Ministerio de Defensa C.A.N. Bogota, Colombia S.A.	1
8. Sr Vicealmirante G. Uribe Comando Armada Nacional Ministerio de Defensa S.A.	1
9. Sr. Contralmirante Director Escuela Naval de Cadetes Cartagena, Colombia S.A.	2
10. Sr. Teniente de Navio M. Soto G. Escuela Naval de Cadetes Cartagena, Colombia S.A.	1
11. Sr. Teniente de Navio J. Matallana R. Escuela Naval de Cadetes Cartagena, Colombia S.A.	3

ATE
LMED
-8