

LEVEL II

12

AD A 096474

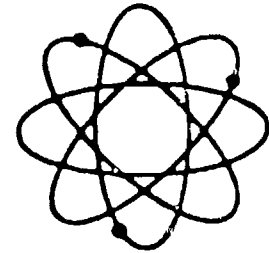

DTIC  
ELECTE  
MAR 17 1981  
S D D

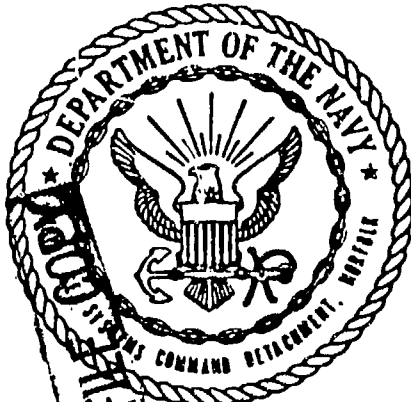

NAVAL SEA SYSTEMS COMMAND DETACHMENT,  
NORFOLK

NAVAL STATION  
NORFOLK, VIRGINIA 23511

DISTRIBUTION STATEMENT A  
Approved for public release;  
Distribution Unlimited

81 3 16 114

12

NAVAL SEA SYSTEMS COMMAND DETACHMENT  
NAVAL STATION  
NORFOLK, VIRGINIA

LEVEL 2

Accession For	
NTIS GRA&I	<input checked="" type="checkbox"/>
DTIC TAB	<input type="checkbox"/>
Unannounced	<input type="checkbox"/>
Justification	
By	
Distribution/	
Availability Codes	
Dist	Avail and/or Special
A	

TEST AND EVALUATION OF THE  
BELL-HALTER 110-FOOT SURFACE EFFECT  
SHIP DEMONSTRATION CRAFT

APPROVED FOR PUBLIC RELEASE: DISTRIBUTION UNLIMITED

Prepared for  
THE UNITED STATES COAST GUARD

By  
Peter K. Spangler

COMBATANT CRAFT ENGINEERING DEPARTMENT  
TEST AND EVALUATION BRANCH

DTIC  
ELECTE  
MAR 17 1981  
S D D

FEBRUARY 1981

NAVSEADET NORFOLK REPORT NO. 6660-60

315 335

UNCLASSIFIED

SECURITY CLASSIFICATION OF THIS PAGE (When Data Entered)

<b>REPORT DOCUMENTATION PAGE</b>		READ INSTRUCTIONS BEFORE COMPLETING FORM	
1. REPORT NUMBER NAVSEADET NORFOLK 6660-60	2. GOVT ACCESSION NO. AD-A096 474	3. RECIPIENT'S CATALOG NUMBER	
4. TITLE (and Subtitle) TEST AND EVALUATION OF THE BELL-HALTER 110-FOOT SURFACE EFFECT SHIP DEMONSTRATION CRAFT.		5. TYPE OF REPORT & PERIOD COVERED 9 FINAL rept.	
7. AUTHOR PETER K. SPANGLER		6. PERFORMING ORG. REPORT NUMBER	
9. PERFORMING ORGANIZATION NAME AND ADDRESS NAVAL SEA SYSTEMS COMMAND DETACHMENT NORFOLK, VIRGINIA 23511		8. CONTRACT OR GRANT NUMBER(s)	
11. CONTROLLING OFFICE NAME AND ADDRESS COMMANDANT (G-DMT-2/TP54) U. S. COAST GUARD WASHINGTON, DC 20593		12. REPORT DATE 11 FEBRUARY 1981	
		13. NUMBER OF PAGES 221	
14. MONITORING AGENCY NAME & ADDRESS (if different from Controlling Office)  12 2-10		15. SECURITY CLASS. (of this report) UNCLASSIFIED	
		15a. DECLASSIFICATION/DOWNGRADING SCHEDULE	
16. DISTRIBUTION STATEMENT (of this Report) APPROVED FOR PUBLIC RELEASE: DISTRIBUTION UNLIMITED			
17. DISTRIBUTION STATEMENT (of the abstract entered in Block 20, if different from Report)			
18. SUPPLEMENTARY NOTES			
19. KEY WORDS (Continue on reverse side if necessary and identify by block number) BELL-HALTER 110-FOOT SURFACE EFFECT SHIP SES USCG CUTTER POINT BROWN (WPB 82362) SEAWORTHINESS TRIALS TEST AND EVALUATION			
20. ABSTRACT (Continue on reverse side if necessary and identify by block number) A technical test and evaluation of the Bell-Halter 110-Foot Surface Effect Ship (SES) demonstration craft was performed during an intensive 30-day test period in the Norfolk, Virginia area. Comparative seaworthiness and towing tests were performed with an 82-foot USCG WPB. Other major test categories yielded speed, range, fuel consumption, directional stability, turning, acceleration, and noise characteristics. Limited maintainability and reliability information was compiled and manning and human factors considerations were studied. -			

DD FORM 1473 1 JAN 73

EDITION OF 1 NOV 65 IS OBSOLETE  
S/N 0102-014-6601

UNCLASSIFIED

SECURITY CLASSIFICATION OF THIS PAGE (When Data Entered)

4 395335

TABLE OF CONTENTS

	PAGE
LIST OF FIGURES .....	iii
LIST OF TABLES .....	vi
ABSTRACT .....	1
ADMINISTRATIVE INFORMATION .....	1
INTRODUCTION .....	3
DESCRIPTION OF THE SES .....	5
TEST RESULTS .....	11
SEAWORTHINESS .....	13
TOWING .....	55
BOLLARD PULL .....	61
SPEED PERFORMANCE .....	63
TURNING AND MANEUVERABILITY .....	67
DIRECTIONAL STABILITY AND IMPAIRED ENGINE TESTS .....	73
ACCELERATION-DECELERATION .....	89
NOISE .....	91
WAKE HEIGHT .....	103
SCALE WEIGHING .....	105
RELIABILITY, MAINTAINABILITY AND MAINTENANCE .....	107
VESSEL MANNING AND HUMAN FACTORS .....	107
DISCUSSION .....	109
CONCLUSIONS .....	115
ACKNOWLEDGEMENTS .....	115
LIST OF REFERENCES .....	117

APPENDICES

Appendix A - Seaworthiness Test Results for the Bell-Halter 110-Foot SES and 82-Foot WPB in Sea States 2 to 4 .....	A-1
Appendix B - Reliability, Maintainability and Maintenance .....	B-1
Appendix C - Vessel Manning Standards and Human Factors Considerations .....	C-1

## LIST OF FIGURES

	PAGE
Figure 1 - Bell-Halter 110-Foot SES Demonstration Craft (Side and Plan View) .....	6
Figure 2 - Bell-Halter 110-Foot SES Demonstration Craft (Quarter View) .....	7
Figure 3 - Bell-Halter 110-Foot SES Seal System .....	8
Figure 4 - Sea Characteristics on Seaworthiness Test Days .....	16
Figure 5 - Craft Headings for Seaworthiness Testing .....	19
Figure 6 - Seaworthiness Transducer Locations and Notation .....	22
Figure 7 - Comparison of Seaworthiness Results for Various Sea States and Headings .....	48
Figure 8 - Various Views of Towing Tests .....	56
Figure 9 - Towing Test Results - SES Towing WPB .....	58
Figure 10 - Towing Test Results - WPB Towing SES .....	59
Figure 11 - Test Arrangement for Bollard Pull .....	61
Figure 12 - Results of Off Cushion Bollard Pull Test .....	62
Figure 13 - RPM, Shaft Horsepower and Fuel Requirements as a Function of Speed .....	64
Figure 14 - Performance with Fixed Propulsion Throttle and Varying Fan Speeds .....	65
Figure 15 - Turning Diameter for Various Rudder Angles and Speeds (On Cushion) .....	68
Figure 16 - Turning Diameter for Various Rudder Angles (Off Cushion) .....	71
Figure 17 - Directional Stability at Normal Low Speed (On Cushion) .....	74

Figure 18 - Directional Stability at Normal High Speed (On Cushion) .....	75
Figure 19 - Directional Stability at Normal Low Speed With Impaired Lift Engine (On Cushion) .....	76
Figure 20 - Directional Stability at Normal Low Speed With Impaired Propulsion Engine (On Cushion) .....	77
Figure 21 - Directional Stability at Normal Low Speed With Impaired Propulsion and Fan Engine (On Cushion) .....	78
Figure 22 - Directional Stability at Normal Low Speed (Off Cushion) .....	79
Figure 23 - Directional Stability at Normal Low Speed With Impaired Propulsion Engine (Off Cushion) .....	80
Figure 24 - Dieudonne Spiral Results for Medium Speed (On Cushion) .....	81
Figure 25 - Dieudonne Spiral Results for High Speed (On Cushion) .....	82
Figure 26 - Dieudonne Spiral Results for Medium Speed with Impaired Lift Engine (On Cushion) .....	83
Figure 27 - Dieudonne Spiral Results for Low Speed with Impaired Propulsion Engine (On Cushion) .....	84
Figure 28 - Dieudonne Spiral Results for Low Speed with Impaired Propulsion and Lift Engine (On Cushion) .....	85
Figure 29 - Dieudonne Spiral Results for Medium Speed (Off Cushion) .....	86
Figure 30 - Dieudonne Spiral Results for Low Speed with Impaired Propulsion Engine (Off Cushion) .....	87
Figure 31 - Ambient Noise Level - Center of Pilot House .....	92
Figure 32 - Ambient Noise Level - Center of Passenger Compartment - Maindeck .....	93
Figure 33 - Ambient Noise Level - Center of Galley Area - Centerline Passageway-Door Open .....	94

LIST OF FIGURES (Cont'd)

	PAGE
Figure 34 - Ambient Noise Level - Center of Galley Area - Centerline Passageway-Door Closed .....	95
Figure 35 - Ambient Noise Level - Engine Room - Midship .....	96
Figure 36 - Ambient Noise Level - Outside - Center Main Foredeck .....	97
Figure 37 - Ambient Noise Level - Outside - Maindeck - Midship .....	98
Figure 38 - Ambient Noise Level - Outside - Center Main Afterdeck .....	99
Figure 39 - Ambient Noise Level - Center of Passenger Compartment - Fans Only .....	100
Figure 40 - Ambient Noise Level - Outside - Center Main Afterdeck - Fans Only .....	101
Figure 41 - Comparative Smooth Water Performance .....	111
Figure 42 - Useful Load Fraction, State-of-the-Art .....	112
Figure 43 - Ride Quality Criteria .....	113

LIST OF TABLES

	PAGE
Table 1 - Physical Characteristics of the Bell-Halter 110-Foot SES Demonstration Craft .....	9
Table 2 - Wind and Sea Scales for Fully Arisen Sea .....	20
Table 3 - Physical Characteristics of USCGC Point Brown (WPB-82362) .....	21
Table 4 - Seaworthiness Test Results in Sea State 2 (29 Feb 1980) .....	23
Table 5 - Seaworthiness Test Results in Low Sea State 3 (27 Feb 1980) ...	32
Table 6 - Seaworthiness Test Results in Low Sea State 4 (26 Feb 1980) ...	34
Table 7 - Seaworthiness Test Results in Sea State 4 (13 Mar 1980) .....	40
Table 8 - Acceleration - Deceleration Test Results .....	90
Table 9 - 110-Foot SES Wake Wave Measurement for Various Speeds and Conditions .....	103

## ABSTRACT

A technical test and evaluation of the Bell-Halter 110-foot Surface Effect Ship (SES) demonstration craft was performed during an intensive 30-day test period in the Norfolk, Virginia area. Comparative seaworthiness and towing tests were performed with an 82-foot USCG WPB. Other major test categories yielded speed, range, fuel consumption, directional stability, turning, acceleration, and noise characteristics. Limited maintainability and reliability information was compiled and manning and human factors considerations were studied. The SES craft was operated in sea state 2 at speeds of 29 knots with significant vertical acceleration peaks in the passenger compartment of 0.6 g and in sea state 4 at 26 knots with peaks of 0.5 g. Maximum vertical acceleration peaks under these conditions were 0.9 and 1.5 g's, respectively. The SES craft towed the 82-foot USCG WPB at speeds to 11 knots. The maximum measured calm water speed of the SES was 33 knots at a displacement of 121 long tons and a fuel consumption of 6.9 gallons per nautical mile yielding a top speed maximum range of 672 nautical miles. Turning performance and directional control were maintained during simulated combinations of propulsion and lift engine impairment.

## ADMINISTRATIVE INFORMATION

The report was prepared by the Combatant Craft Department of the Naval Sea Systems Command Detachment, Norfolk, for the Commandant (G-DMT-2/TP54), United States Coast Guard. Direction and funding was provided under MIPR Z-70099-0-019283 of 20 Dec 1979 titled "Surface Effect Ship Test and Evaluation - Phase I - Test Preparation" and Z-70099-0-019283-A of 5 Feb 1980 titled "Surface Effect Ship Test and Evaluation - Phase II - Testing."

## INTRODUCTION

The United States Coast Guard (USCG) and the Urban Mass Transportation Administration (UMTA), separate agencies under the Department of Transportation, are evaluating a number of "advanced" marine vehicles for use in various roles. The USCG is considering advanced craft as possible replacements for aging cutter classes, while UMTA's interest stems from its High Speed Waterborne Transportation Demonstration Project - a program to demonstrate the suitability of high speed advanced vehicles in a marine ferry application. To gain information on a candidate concept, the large displacement sidehull surface effect ship, the USCG and UMTA developed a joint program to test an operating commercial variant of this type of craft - the Bell-Halter 110-foot Surface Effect Ship (BH-110 SES) demonstration craft. The data gained from the tests will be incorporated into each agency's program and will aid in formulating decisions in relation to the use of advanced craft.

The Coast Guard, as the joint program manager, tasked the Combatant Craft Department of the Naval Sea Systems Command Detachment, Norfolk, with testing the BH-110 SES demonstration craft to obtain an independently generated data base on the craft's abilities. The testing included quantitative evaluations of seaworthiness, speed performance, maneuvering, towing, onboard noise, reliability/maintainability, and vessel-crew interface considerations.

This report presents the results of the tests in tabulated and graphical form. Seaworthiness test results are presented as a tabulated statistical data analysis in the main report and are accompanied by more comprehensive chronological and ranked results for each parameter in an appendix.

The SES, with operating crew, was leased by the Coast Guard from Bell-Halter, a joint venture of Bell Aerospace/Textron and Halter Marine, Inc., for 30 days of testing (13 February - 14 March 1980) in the Norfolk, Virginia area. All tests were conducted in the lower Chesapeake Bay and Atlantic Ocean adjacent to the mouth of the Chesapeake Bay and Virginia Beach, Virginia.

## DESCRIPTION OF THE SES

The Bell-Halter 110-foot SES demonstration craft is an air-cushion assisted craft capable of on-cushion speeds in excess of 30 knots with a normal load in calm water. The craft rides on a resistance-reducing cushion of fan-supplied air contained by catamaran style sidehulls and flexible bow and stern seals. The hull is fabricated from conventional welded marine aluminum while the bow and stern seals are fabricated from a flexible elastomer coated nylon material. Profile and quarter-view sketches of the SES are presented in figures 1 and 2. Figure 3 is a sketch showing the cushion containing seal system with forward "bow-fingers," catamaran style sidehulls, and three compartment "folded bag" stern seals. Fan-forced cushion air is inducted through screens aft of the deckhouse (figure 2) and supplied to the cushion through longitudinal ducts (not shown) to rectangular orifices aft of the leading edge of the bow-fingers, amidship in the cross structure "wet deck" (shown in figure 3), and aft into the stern seal bags. Physical characteristics of the SES, as tested, are given in table 1.

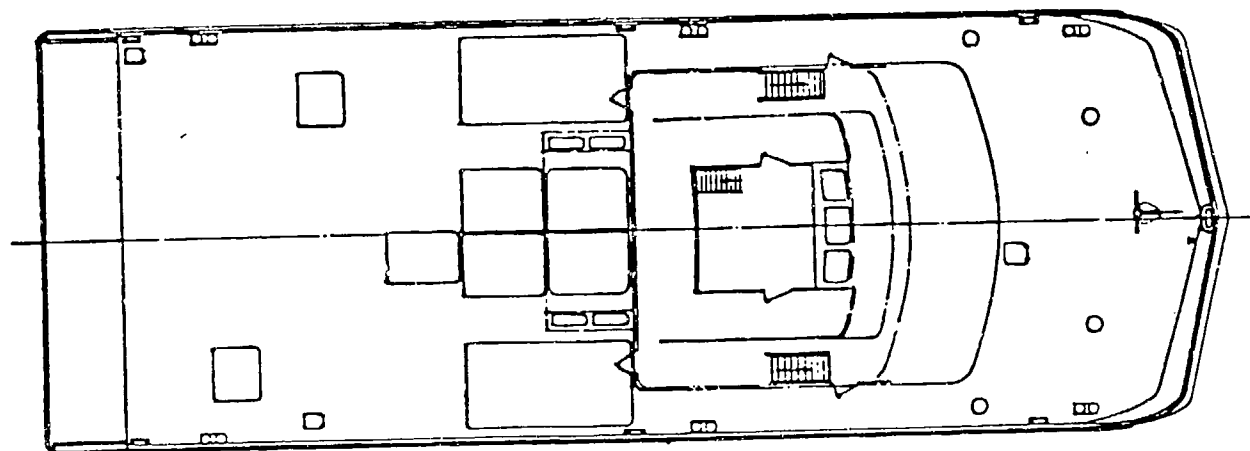
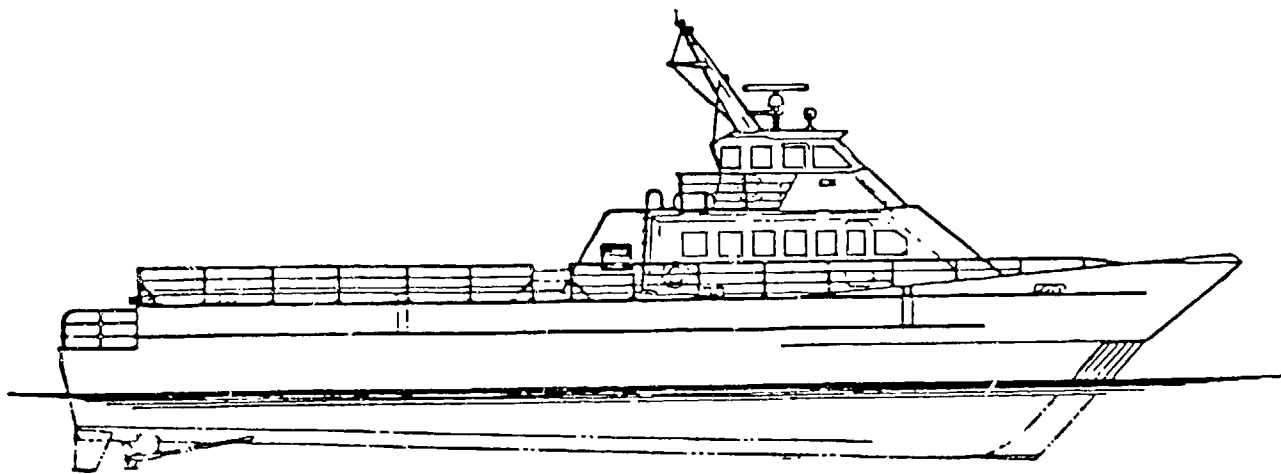

FIGURE 1. BELL-HALTER 110-FOOT SES DEMONSTRATION CRAFT  
(SIDE AND PLAN VIEW)

Reprinted from Reference 1 by permission of Bell-Halter, Inc.

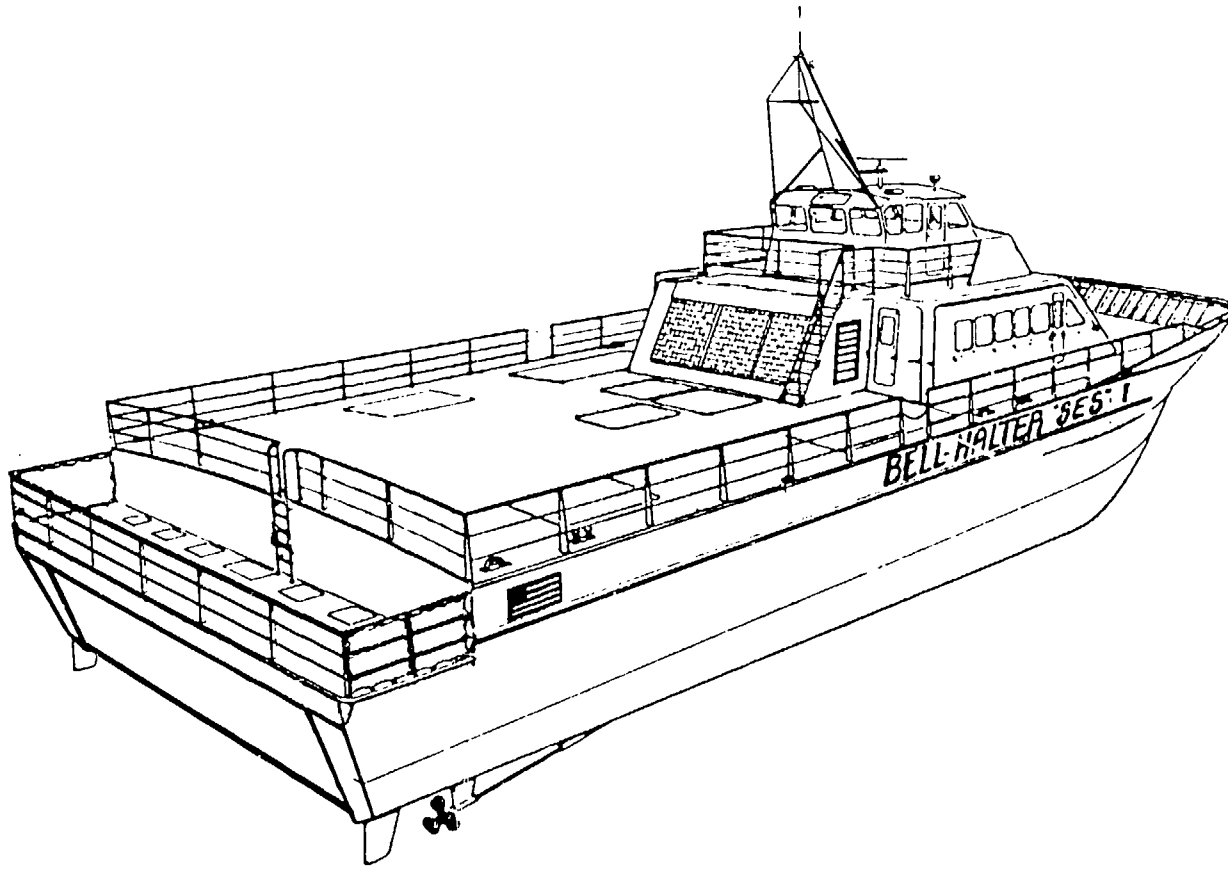

FIGURE 2. BELL-HALTER 110-FOOT SES DEMONSTRATION CRAFT  
(QUARTER VIEW)

Reprinted from Reference 2 by permission of Bell-Halter, Inc.

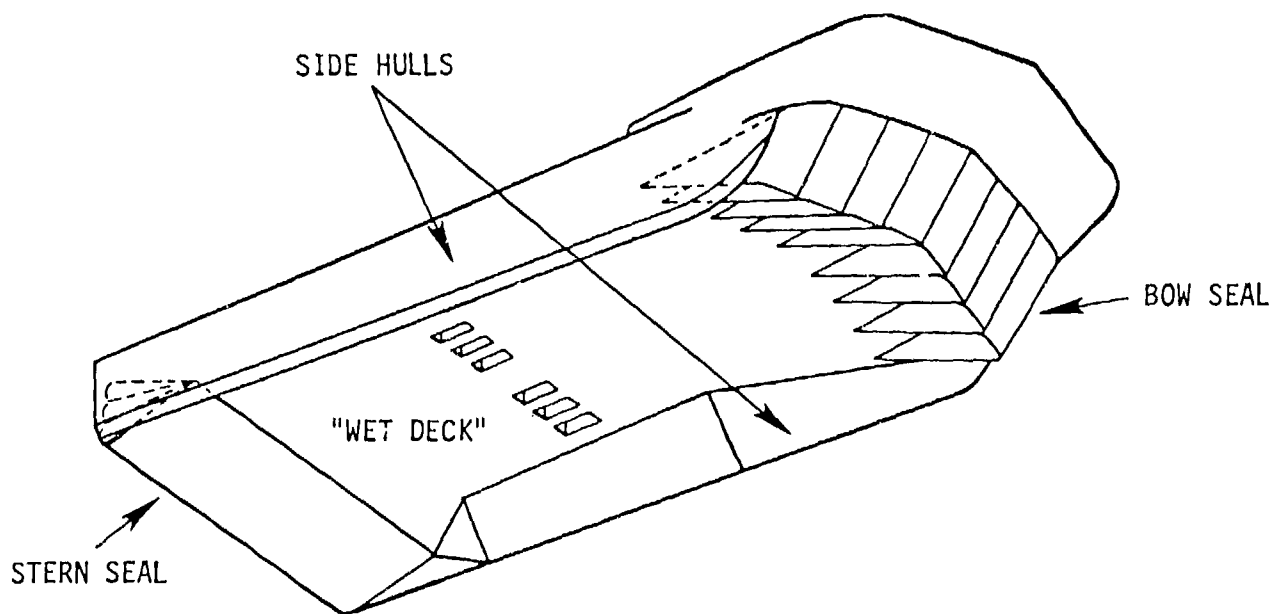

FIGURE 3. BELL-HALTER 110 FOOT SES SEAL SYSTEM

Reprinted from Reference 2 by permission of Bell-Halter, Inc. (labels added)

TABLE 1. PHYSICAL CHARACTERISTICS OF THE BELL-HALTER 110-FOOT SES  
DEMONSTRATION CRAFT

<u>DIMENSIONS</u>	
LENGTH	110 FT.
BEAM	39 FT.
HEIGHT (ON CUSHION)	28 FT.
DRAFT (OFF CUSHION, STATIC MEAN)	
272,000 LB. DISP.	7.7 FT.
314,000 LB. DISP.	8.2 FT.
<u>LOADING PARTICULARS</u>	
MAXIMUM DISPLACEMENT TESTED (314,000 LBS.)	140.2 LT.
NORMAL DISPLACEMENT TESTED (272,000 LBS.)	121.4 LT.
LIGHT DISPLACEMENT (NO LIQUIDS) (223,200 LBS.)	99.6 LT.
FUEL CAPACITY AS TESTED (NORMAL, 2 TANKS)	3100 GAL.
(MAXIMUM, 4 TANKS)	4640 GAL.
POTABLE WATER (2 TANKS)	384 GAL.
WASTE WATER (2 TANKS)	342 GAL.
BALLAST WATER (6 TANKS)	8990 GAL.
CARGO DECK AREA	1672 FT. <sup>2</sup>
SEATS FOR PASSENGERS (TESTED CONFIGURATION)	65
<u>MACHINERY</u>	
PROPULSION:	
<ul style="list-style-type: none"> <li>● TWO 16V149TI DETROIT DIESEL MARINE ENGINES (EACH 1440 SHP @ 1900 RPM, 180 INJECTORS)</li> <li>● TWO 41.9 IN. DIA. BY 50.5 IN. FIXED PITCH PROPELLERS</li> </ul>	
LIFT SYSTEM:	
<ul style="list-style-type: none"> <li>● TWO 8V92TI DETROIT DIESEL MARINE ENGINES (EACH 435 SHP @ 2100 RPM, 9290 INJECTORS)</li> <li>● TWO DOUBLE WIDTH - DOUBLE ENTRY CENTRIFUGAL FANS, 42 IN. DIA.</li> </ul>	
GENERATORS:	
● MAIN - DDAD-3-71-GM MODEL 1033-7005	55 KW
● STANDBY - KATO KAMAG 14	40 KW
<u>RANGE</u>	
NORMAL DISPLACEMENT, CALM SEA, 95% NORMAL FUEL CAPACITY, 30 KTS	471 NM
MAXIMUM DISPLACEMENT, CALM SEA, 95% NORMAL FUEL CAPACITY, 24 KTS	398 NM

## TEST RESULTS

The results of the various test procedures are presented in the order of priority established in references 3 and 4<sup>1</sup>. The order of priority guided test procedure selection during the condensed test period; however, all test items were accomplished with the exception of operation in ice (not available) and the verification of inclining parameters. The test period, including installation and removal of equipment and instrumentation, was during February and March 1980. The scale-weighing section of the static parameter test was performed later, in May 1980, at Halter Marine Inc. facilities in New Orleans, Louisiana. A daily record was maintained throughout the test period of the craft draft and/or freeboard, fuel status, and major increments of payload added or removed. Following the scale-weighing in May, the measured scale weight and daily records, in conjunction with the vessel curves of form (Bell-Halter dwg. no. JVC2, Rev. 2), were used to estimate the craft displacement for each test sequence. These determined values for displacement are used throughout this report and the test results.

<sup>1</sup> References are listed on page 113.

## SEAWORTHINESS

Seaworthiness testing was conducted on four different days at four different locations to obtain low, medium, and high sea state results. Low sea state testing was performed on 29 February 1980 in the "Tail of the Horseshoe" west of the Chesapeake Bay Bridge Tunnel (CBBT). Medium sea state testing was performed on 26 February in the Chesapeake Channel east of the CBBT and on 27 February in the Atlantic 5 to 8 miles east of Virginia Beach. High sea state testing was performed on 13 March in the Atlantic 14 to 17 miles east of Virginia Beach near the Chesapeake Light Tower. A wave buoy that generated a wave height time history via radio link was used at each test site to obtain data from which sea state determination was statistically and graphically analyzed. The statistical wave height parameters and energy spectrum plots of wave energy content are presented in figure 4 for each test condition. Sea state values were determined utilizing the wind and sea scales of table 2, considering primarily the wave period at peak spectral energy and significant and average 1/10 highest wave height.

Seaworthiness test procedures called for operation of the SES and the USCGC Point Brown (WPB-82362), an 82-foot patrol boat, side-by-side on a partial octagon maneuver as shown in figure 5. Physical characteristics of the Point Brown are presented in table 3. This procedure was repeated for low, medium, and high sea states at low speed (approximately 10 knots), high speed for the WPB (approximately 18 knots), and with the SES solo at a high speed for the SES (approximately 29 knots). This program yielded 52 sea-heading-speed combinations for the SES, 30 of these combinations side-by-side with the WPB. The parameters measured during seaworthiness testing and recorded on magnetic tape for subsequent computer analysis were vertical, longitudinal, and transverse linear acceleration at approximately the vessel center of gravity (c.g.), bow and stern vertical accelerations, and pitch and roll angle. The location of the transducers for these measurements (for both vessels) and the notation used in reporting the statistically analyzed results are presented in figure 6. The analysis consisted of measuring the magnitude above and below a nominal zero value of each peak and each trough in the time history of each parameter for each approximately 10-minute duration run. The resulting groups of peak and trough values were then ranked by magnitude and the average value, average of the 1/3 highest (significant) value, average of the 1/10 highest values, and the maximum value in the sample were computed and listed. These results are presented in tables 4, 5, 6, and 7 for each of the four seaworthiness test days and in order of increasing sea state. The results within each table are identified by a run number and, where applicable, SES and WPB results appear on opposing pages to facilitate direct comparison under identical sea and operating conditions. Longitudinal acceleration (LNCGAC) is analyzed and presented only for high sea state conditions (table 7) due to the relatively low levels of magnitude of the parameter. Bow and stern vertical acceleration (VBOWAC and VSTRNA) are missing from the WPB results in table 6 due to the loss of those transducers at the start of that test sequence.

A more comprehensive presentation of seaworthiness results is presented in Appendix A. The aforementioned statistical results are repeated along with a listing of mean value, number of peaks, and root mean square (rms) value for each parameter during each trial run. The rms values present a measure of relative energy content experienced during the run (and between various runs) among parameters of similar units (pitch and roll angles in degrees, accelerations in g's). A chronological listing of each peak and each trough, for each parameter, is included (starting from the beginning of each run up to a maximum of the first 16 data points) that gives a sense of the sequential occurrence of events during the run. A ranked listing of peaks and troughs is also presented for each parameter starting with the largest magnitude measured during the run and progressing down through a maximum number of 16 data points. Appendix A information is grouped according to test days (sea states) and is arranged for comparison of the SES with the WPB.

In table 4 (sea state 2) runs 1 - 5 give the response of the SES when hove-to or with zero ahead speed at different aspects to a low sea state. Motions and accelerations were very modest. Runs 6 - 10 show the SES, at high speed, having low pitch and roll motions but significant (avg. 1/3 highest) accelerations in the 0.5 to 0.7 g range. Runs 11 - 20 compare SES to WPB at low and medium speed and show the SES experiencing several orders of magnitude less motion than the WPB. Motions and accelerations are presented graphically as a function of speed in figures 7a and 7b for the two craft on headings yielding the largest response. The WPB is particularly vulnerable to following and quartering seas, a phenomena that was visually apparent during all seaworthiness testing. Accelerations are of similar magnitude for the two craft at low and medium speeds except in bow seas where they are higher on the WPB.

Table 5 presents high speed results for the SES in a slightly greater sea state than table 4. Motions are similar to high speed results in table 4 (runs 6 - 10) and significant accelerations show a slight increase in magnitude.

A comparison of significant motion measurements in table 6 for low and medium speeds in a medium sea state shows the SES and WPB to have similar and modest pitch response. SES significant roll response is low, generally less than 5 degrees; however, WPB roll response is 2 to 3 times greater. Vertical accelerations at the c.g. are similar for both craft except at low speed in head seas where the SES is higher.

Table 7 compares seaworthiness results in a fully developed sea state 4, the highest sea state tested. Runs 1 - 10 for low and medium speeds yield significant pitch motion results that are modest for the sea condition and slightly greater for the SES than the WPB. Roll again is 2 to 3 times greater for the WPB. Significant accelerations are similar for the two craft except in bow and head sea aspects where the WPB accelerations are higher or equal at the bow and c.g. locations but lower at the stern. At high speed (runs 11 - 16), the SES pitch and roll motions remain modest for the sea conditions and approximately the same magnitude as at lower speeds. Significant accelerations exceed 0.7 g. at the bow for the only time during the test on head and bow sea headings (run 11 and 15) with corresponding c.g. accelerations reaching 0.5 g. Significant (avg 1/3 highest) and (average 1/10 highest) motions and accelerations are compared graphically in figures 7c, 7d, 7e, and 7f for the two craft. The SES was held stern-to the seaway with no

headway during run 17. Pitch and roll motions were similar to motions at low, medium, and high speed on the same heading and accelerations were less, as would be expected.

In summation, the SES and WPB exhibit approximately the same acceleration response to rough seas but the SES is at least an order of magnitude better in roll motion response. The above, coupled with a higher speed capability, results in this SES type craft being the better rough water craft from a mission completion time and crew comfort and fatigue consideration. However, the motion of this SES at high speeds in moderately rough seas, and at any speed in the roughest seas experienced, made it difficult, and at times hazardous, for personnel to safely move about the craft. The spacious interior of this demonstration craft contributed to the problem. Sturdy pipe handrails and handholds need to be installed along all passageways and stairs. Passenger seating would be improved by the installation of seatbelts.

SEA CONDITION ON 2-29-80: SEA STATE 2  
 WAVE HTS. (FT.): AVG. 2.0, AVG. 1/3 HIGH 2.7, AVG. 1/10 HIGH 3.5

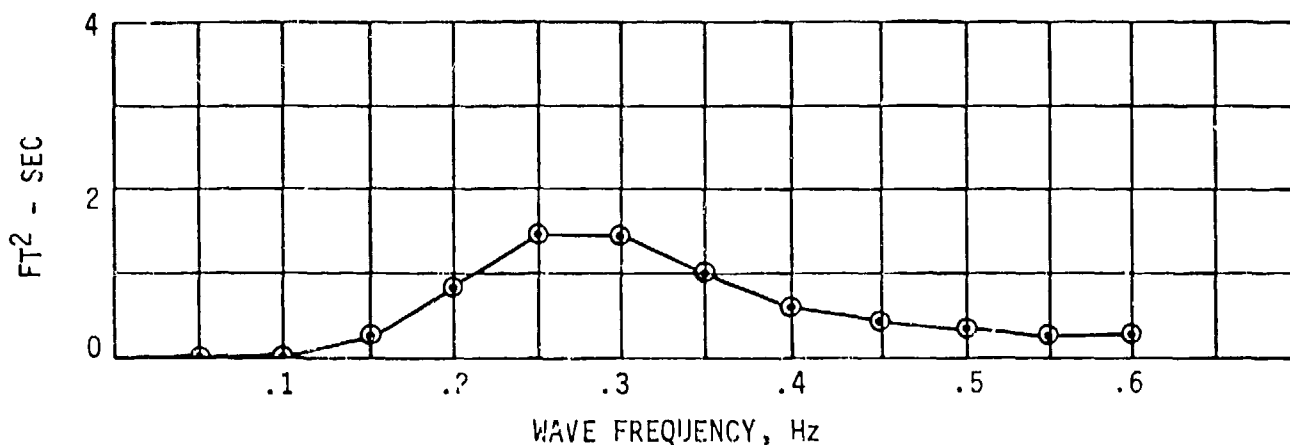

FIGURE 4(a)

SEA CONDITION ON 2-27-80: LOW SEA STATE 3  
 WAVE HTS. (FT.): AVG. 2.2, AVG. 1/3 HIGH 3.1, AVG. 1/10 HIGH 4.2

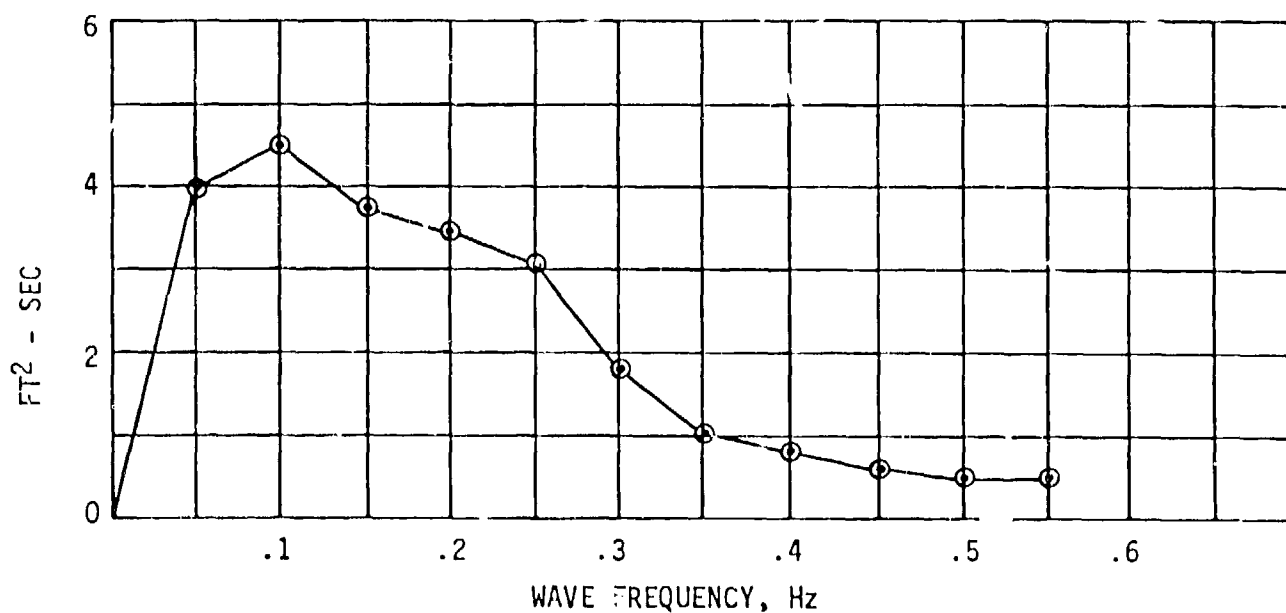

FIGURE 4(b)

FIGURE 4. SEA CHARACTERISTICS ON SEAWORTHINESS TEST DAYS

SEA CONDITION ON 2-26-80: LOW SEA STATE 4

WAVE HTS. (FT.): AVG. 4.3, AVG. 1/3 HIGH 6.0, AVG. 1/10 HIGH 7.3

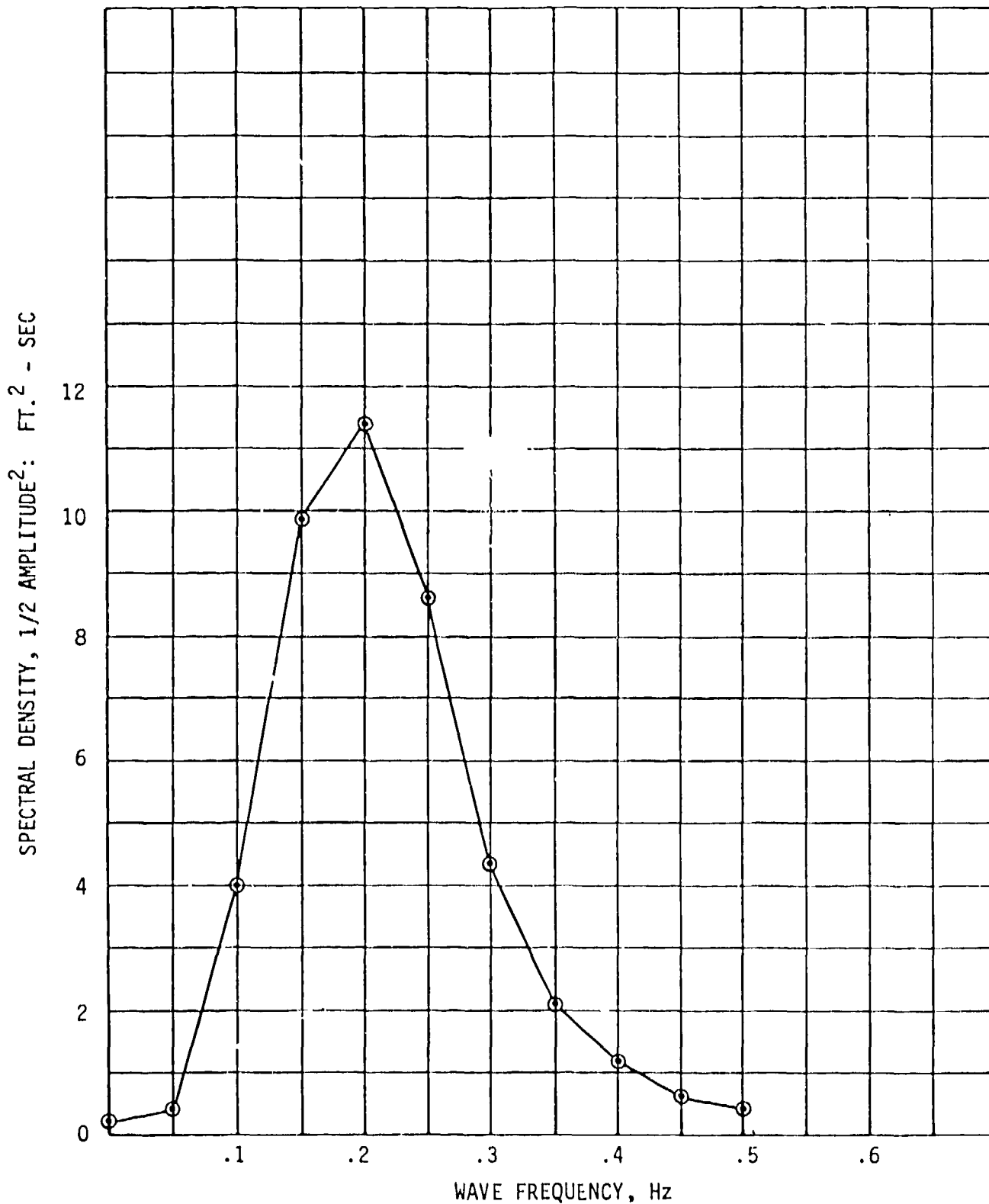

FIGURE 4(c)

FIGURE 4. SEA CHARACTERISTICS ON SEAWORTHINESS TEST DAYS (Continued)

SEA CONDITION ON 3-13-80: SEA STATE 4

WAVE HTS. (FT.): AVG. 4.6, AVG. 1/3 HIGH 6.4, AVG. 1/10 HIGH 7.7

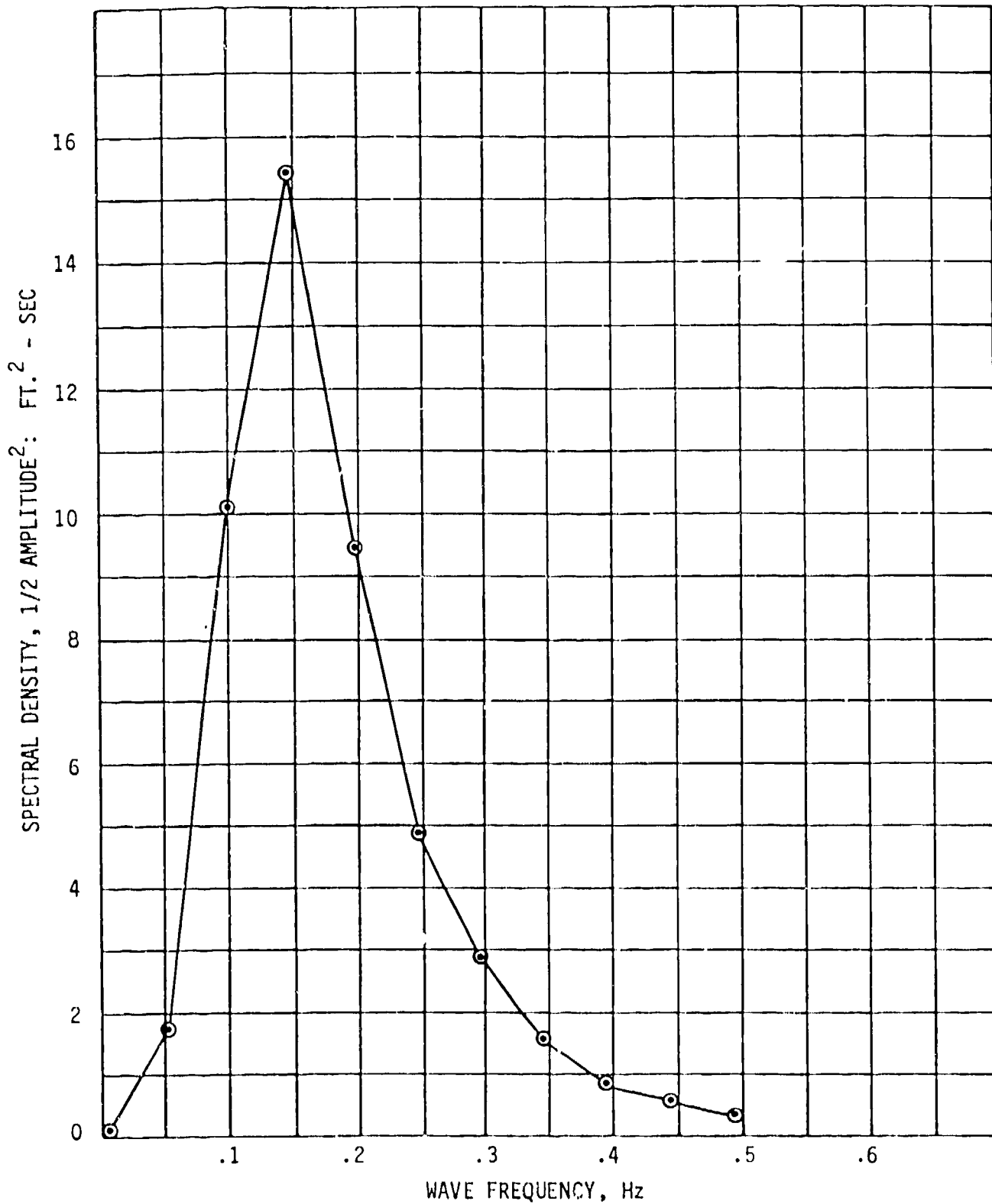

FIGURE 4(d)

FIGURE 4. SEA CHARACTERISTICS ON SEAWORTHINESS TEST DAYS (Continued)

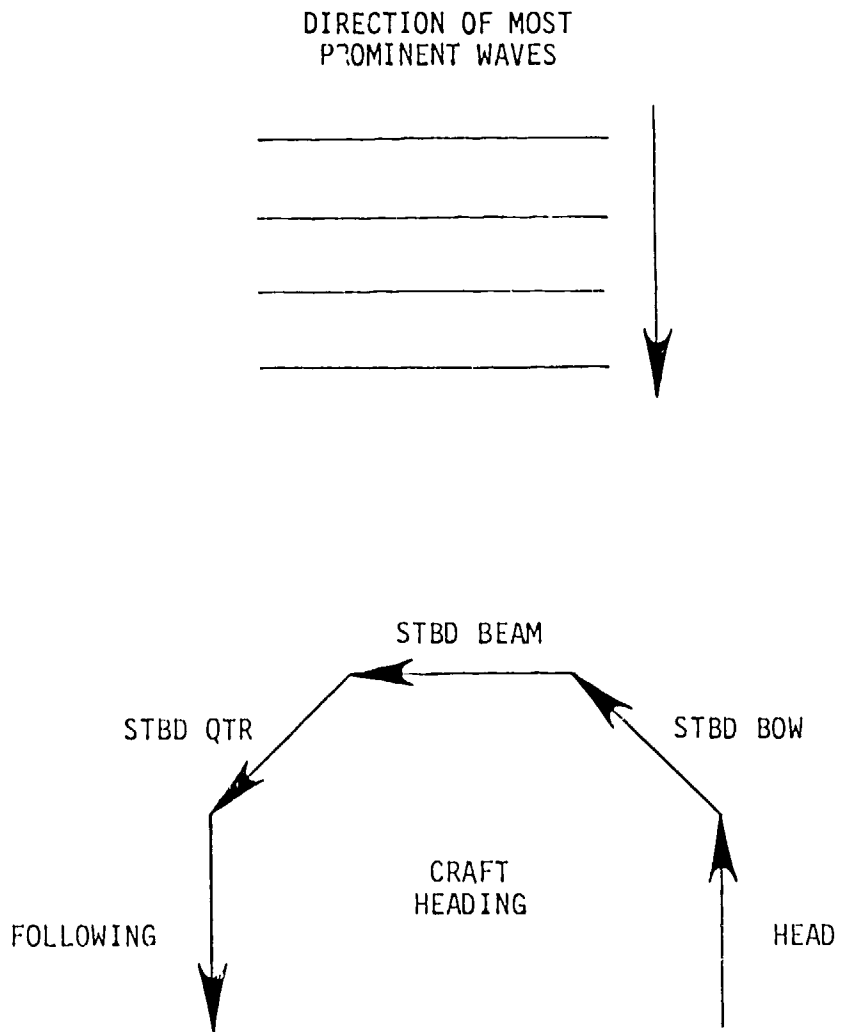

FIGURE 5. CRAFT HEADINGS FOR SEAWORTHINESS TESTING

TABLE 2. WIND AND SEA SCALES FOR FULLY ARISEN SEA

WIND AND SEA SCALE FOR FULLY ARISEN SEA														
SEA-GENERAL			WIND <sup>1)</sup>						SEA <sup>2)</sup>					
SEA STATE <sup>1)</sup>	DESCRIPTION <sup>2)</sup>	IDENTIFY WIND FORCE	DESCRIPTION	LESS THAN 1 <sup>3)</sup>	RANGE (KNOTS)	WIND VELOCITY (KNOTS)	AVERAGE	SIGNIFICANT	WAVE HEIGHT FEET	SIGNIFICANT RANGE OF PERIODS (SECONDS)		PERIOD OF RAYLEIGH ENERGY OF SPECTRUM		MINIMUM PERIOD (SECONDS)
								AVERAGE TO HIGHEST	AVERAGE TO HIGHEST	T <sub>0.5</sub>	T <sub>1</sub>	T <sub>0.5</sub>	T <sub>1</sub>	MINIMUM PERIOD (SECONDS)
0	Sea like a mirror.	0	Calm	Less than 1	0	0	0	0	—	—	—	—	—	—
	Ripples with the appearance of scales are formed, but without foam crests.	1	Light Air	1-3	2	0.05	0.08	0.10	up to 1.2 sec	0.7	0.5	10	5	8 min
1	Small wavelets, still short but more pronounced; crests have a glassy appearance, but do not break.	2	Light Breeze	4-6	3	0.18	0.29	0.37	0.4-2.8	2.0	1.4	6.7	8	39 min
	Large wavelets, crests begin to break. Form of glassy appearance. Perhaps scattered white horses.	3	Gentle Breeze	7-10	4	0.6	1.0	1.2	0.8-5.0	3.4	2.4	20	9.8	1.7 hrs
2					5	0.88	1.4	1.8	1.0-6.0	4	2.9	27	10	2.4
					6	1.4	2.2	2.8	1.0-7.0	4.8	3.4	40	18	3.8
3	Small waves, becoming larger; fairly frequent white horses.	4	Moderate Breeze	11-16	7	1.8	2.9	3.7	1.4-7.4	5.4	3.9	52	24	4.8
					8	2.0	3.3	4.2	1.5-7.8	5.6	4.0	59	28	5.2
4					9	2.9	4.6	5.8	2.0-8.8	6.5	4.6	71	40	6.6
5	Moderate waves, taking a more pronounced long form; many white horses are formed. (Chance of some spray).	5	Fresh Breeze	17-21	10	3.8	6.1	7.8	2.5-10.0	7.2	5.1	90	55	8.3
					11	4.3	6.9	8.7	2.8-10.6	7.7	5.4	99	65	9.2
6					12	5.0	8.0	10	3.0-11.1	8.1	5.7	111	75	10
7	Large waves begin to form; the white foam crests are more extensive everywhere. (Probably some spray).	6	Strong Breeze	22-27	13	6.4	10	13	3.4-12.2	8.9	6.3	134	100	12
					14	7.9	12	16	3.7-13.3	9.7	6.8	160	130	14
8					15	8.7	13	17	3.8-13.6	9.9	7.0	164	140	15
9	Sea heaps up and white foam from breaking waves begins to be blown in streaks along the direction of the wind. (Sprindrift begins to be seen).	7	Moderate Gale	28-33	16	9.6	15	20	4.0-14.3	10.5	7.4	188	180	17
					17	11	18	23	4.5-15.5	11.3	7.9	212	230	20
10					18	14	22	28	4.7-16.7	12.1	8.4	250	280	23
					19	14	23	29	4.8-17.0	12.4	8.7	258	290	24
11	Moderately high waves of greater length; edges of waves break into spindrift. The foam is blown in well marked streaks along the direction of the wind. Spray affects visibility.	8	Fresh Gale	34-40	20	16	26	33	5.0-17.5	12.9	9.1	285	340	27
					21	19	30	38	5.5-18.5	13.6	9.7	322	420	30
12					22	21	35	44	5.8-19.7	14.5	10.3	363	500	34
					23	23	37	46.7	6-20.5	14.9	10.5	376	530	37
13					24	25	40	50	6.2-20.8	15.4	10.7	392	600	38
14					25	28	45	58	6.5-21.7	16.1	11.4	444	710	42
15	High waves. Dense streaks of foam along the direction of the wind. Sea begins to roll. Visibility affected.	9	Strong Gale	41-47	26	31	50	64	7-23	17.0	12.0	492	830	47
					27	36	58	73	7-24.2	17.7	12.5	534	960	52
16					28	40	64	81	7-25	18.4	13.1	590	1110	57
17					29	44	71	90	7.5-26	19.4	13.8	650	1250	63
18	Very high waves with long or whanging crests. The resulting foam is in great patches and is blown in dense white streaks along the direction of the wind. On the whole the surface of the sea takes a white appearance. The rolling of the sea becomes heavy and shuddering. Visibility is affected.	10	Whole Gale*	48-55	30	49	78	99	7.5-27	20.2	14.3	700	1420	69
					31	52	83	106	8-28.2	20.8	14.7	736	1560	73
19					32	54	87	110	8-28.5	21.0	14.8	750	1610	75
					33	59	95	121	8-29.5	21.8	15.4	810	1800	81
20	Exceptionally high waves (Small and medium-sized ships might for a long time be lost to view behind the waves.) The sea is completely covered with long white patches of foam lying along the direction of the wind. Everywhere the edges of the waves are blown into froth. Visibility affected.	11	Storm*	56-63	34	64	103	130	8.5-31	22.6	16.3	910	2100	88
					35	73	116	148	10-32	24	17.0	985	2500	101
21	Air filled with foam and spray. Sea completely white with driving spray; visibility very seriously affected.	12	Hurricane*	64-71	> 64	> 80 <sup>b)</sup>	> 120 <sup>b)</sup>	> 164 <sup>b)</sup>	10-(35)	(74)	(18)	~	~	~

\*For hurricane winds (and often whole gale and storm winds) required directions and fetches are rarely attained. Seas are therefore not fully arisen.

a) A heavy bar around this value means that the values tabulated are at the center of the Deaufort range.

b) For such high winds, the seas are confused. The wave crests blow off, and the water and the air mix.

1) Encyclopaedia of Nautical Knowledge, W.A. McEwen and A.H. Lewis, Cornell Maritime Press, Cambridge, Maryland, 1953, p. 483

2) Manual of Seamanship, Volume II, Admiralty, London, H.M. Stationery Office, 1952, pp. 717-718

3) Practical Methods for observing and forecasting Ocean Waves, Pearson, Newman, Jones, N.Y. Univ. College of Engin, 1953.

This table compiled by Hilbur Harkes, David Taylor Model Basin

TABLE 3. PHYSICAL CHARACTERISTICS OF USCGC POINT BROWN (WPB-82362)

<u>DIMENSIONS</u>	
LENGTH OVERALL	83 FEET
BEAM	18 FEET
DRAFT	6 FEET
<u>LEADING PARTICULARS</u>	
DISPLACEMENT	66 LONG TONS
POWER/SHAFT (TWIN SCREW)	800 HORSEPOWER
MAXIMUM SPEED	23.7 KNOTS
ECONOMICAL SPEED	8.0 KNOTS
RANGE @ MAXIMUM SPEED	490 NAUTICAL MILES
RANGE @ ECONOMICAL SPEED	1500 NAUTICAL MILES

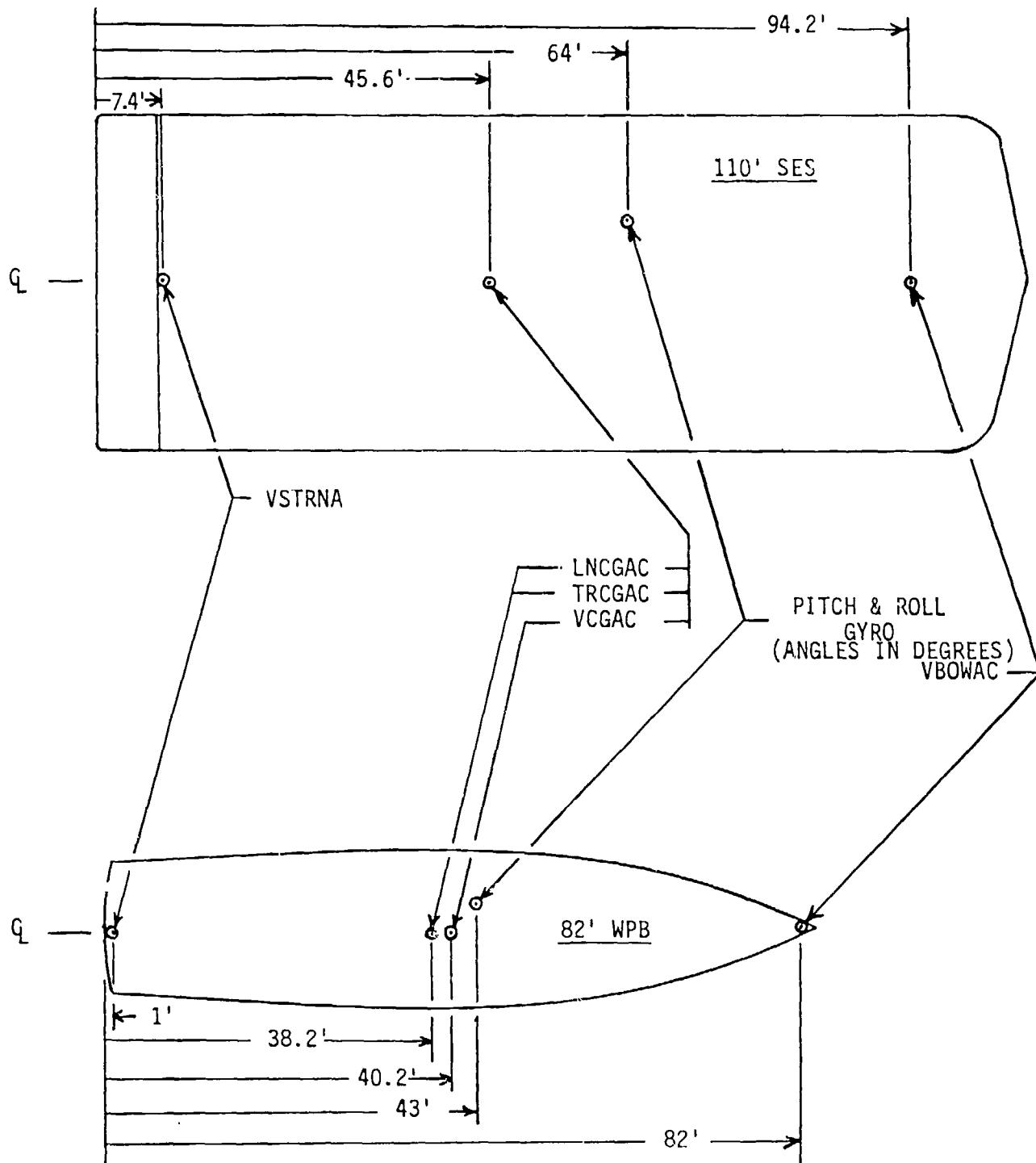

NOTATION

VBOWAC: VERTICAL BOW ACCELERATION, g's

VSTRNA: VERTICAL STERN ACCELERATION, g's

VCGAC: VERTICAL C.G. ACCELERATION, g's

TRCGAC: TRANSVERSE C.G. ACCELERATION, g's

LNCGAC: LONGITUDINAL C.G. ACCELERATION, g's

(VERTICAL DENOTES PARALLEL TO INTERSECTION OF MAJOR BULKHEADS AND CENTERLINE FORE-AFT PLANE)

FIGURE 6. SEAWORTHINESS TRANSDUCER LOCATIONS AND NOTATIONS

TABLE 4. SEAWORTHINESS TEST RESULTS IN SEA STATE 2 (29 FEB 1980)

RUN 1 HEAD SEA, SES, 0 KNOTS - D I W

229S01

	AVERAGE		AVE 1/3		AVE 1/10		MAX	
	PK	TR	PK	TR	PK	TR	PK	TR
PITCH	1.85	-1.80	2.81	-2.68	3.39	-3.18	3.86	-3.68
ROLL	0.72	-0.87	0.95	-1.14	1.16	-1.35	1.37	-1.56
VBOWAC	0.15	-0.06	0.20	-0.11	0.23	-0.14	0.26	-0.21
VSTRNA	0.12	-0.06	0.15	-0.10	0.17	-0.12	0.22	-0.15
VCGAC	0.00	-0.00	0.00	-0.00	0.00	-0.00	0.00	-0.00
TRCGAC	0.01	-0.05	0.03	-0.06	0.06	-0.07	0.09	-0.08

RUN 2 S, BOW SEA, SES, 0 KNOTS - D I W

229S02

	AVERAGE		AVE 1/3		AVE 1/10		MAX	
	PK	TR	PK	TR	PK	TR	PK	TR
PITCH	1.41	-1.37	2.16	-2.10	2.67	-2.68	3.04	-3.06
ROLL	1.94	-1.91	3.05	-3.09	3.96	-4.02	5.22	-5.08
VBOWAC	0.13	-0.04	0.17	-0.07	0.20	-0.09	0.23	-0.11
VSTRNA	0.11	-0.04	0.13	-0.07	0.15	-0.09	0.17	-0.10
VCGAC	0.10	-0.00	0.11	-0.01	0.11	-0.02	0.11	-0.02
TRCGAC	0.03	-0.08	0.05	-0.11	0.07	-0.14	0.10	-0.18

RUN 3 S, BEAM SEA, SES, 0 KNOTS - D I W

229S03

	AVERAGE		AVE 1/3		AVE 1/10		MAX	
	PK	TR	PK	TR	PK	TR	PK	TR
PITCH	0.85	-0.86	1.16	-1.18	1.41	-1.43	1.68	-1.99
ROLL	3.43	-3.17	5.40	-5.00	6.72	-6.19	8.64	-7.57
VBOWAC	0.13	-0.03	0.16	-0.07	0.18	-0.08	0.23	-0.13
VSTRNA	0.10	-0.04	0.11	-0.05	0.12	-0.07	0.13	-0.07
VCGAC	0.10	-0.02	0.11	-0.03	0.12	-0.04	0.12	-0.05
TRCGAC	0.05	-0.11	0.09	-0.15	0.11	-0.19	0.14	-0.21

TABLE 4. SEAWORTHINESS TEST RESULTS IN SEA STATE 2 (29 FEB 1980)  
(CONTINUED)

RUN 4 S. QUARTERING SEA, SES, 0 KNOTS - D I W 229504

	AVERAGE		AVE 1/3		AVE 1/10		MAX	
	PK	TR	PK	TR	PK	TR	PK	TR
PITCH	1.26	-1.22	1.88	-1.79	2.29	-2.19	2.57	-2.60
ROLL	1.58	-1.37	2.51	-2.27	3.19	-2.88	4.00	-3.27
V <sub>BOW</sub> AC	0.13	-0.03	0.18	-0.07	0.22	-0.10	0.28	-0.13
V <sub>STRNA</sub>	0.10	-0.05	0.13	-0.09	0.16	-0.11	0.20	-0.13
V <sub>CG</sub> AC	0.11	-0.01	0.13	-0.03	0.15	-0.04	0.15	-0.05
TR <sub>CG</sub> AC	0.02	-0.07	0.04	-0.09	0.05	-0.11	0.07	-0.12

RUN 5 FOLLOWING SEA, SES, 0 KNOTS - D I W 229505

	AVERAGE		AVE 1/3		AVE 1/10		MAX	
	PK	TR	PK	TR	PK	TR	PK	TR
PITCH	1.28	-1.26	1.98	-1.89	2.45	-2.27	2.95	-2.73
ROLL	0.94	-0.84	1.32	-1.19	1.60	-1.50	1.81	-1.76
V <sub>BOW</sub> AC	0.13	-0.02	0.17	-0.06	0.20	-0.09	0.24	-0.16
V <sub>STRNA</sub>	0.10	-0.05	0.12	-0.08	0.15	-0.10	0.19	-0.13
V <sub>CG</sub> AC	0.11	-0.01	0.12	-0.02	0.13	-0.04	0.14	-0.04
TR <sub>CG</sub> AC	0.01	-0.06	0.02	-0.07	0.02	-0.08	0.03	-0.08

RUN 6 HEAD SEA, SES, APPROX. 29 KNOTS 229506

	AVERAGE		AVE 1/3		AVE 1/10		MAX	
	PK	TR	PK	TR	PK	TR	PK	TR
PITCH	0.52	-1.05	0.68	-1.58	0.72	-2.03	0.72	-2.03
ROLL	0.90	-0.63	1.45	-0.89	2.03	-1.07	2.10	-1.17
V <sub>BOW</sub> AC	0.48	-0.32	0.69	-0.46	0.91	-0.57	1.46	-0.75
V <sub>STRNA</sub>	0.38	-0.28	0.48	-0.36	0.61	-0.42	0.77	-0.55
V <sub>CG</sub> AC	0.44	-0.27	0.58	-0.36	0.73	-0.42	0.94	-0.52
TR <sub>CG</sub> AC	0.04	-0.07	0.04	-0.08	0.05	-0.09	0.05	-0.09

RUN 7 FOLLOWING SEA, SES, APPROX. 29 KNOTS 229507

	AVERAGE		AVE 1/3		AVE 1/10		MAX	
	PK	TR	PK	TR	PK	TR	PK	TR
PITCH	0.99	-1.01	1.40	-1.50	1.70	-1.84	2.13	-2.26
ROLL	0.77	-0.93	1.40	-1.55	1.84	-2.12	2.15	-2.54
V <sub>BOW</sub> AC	0.35	-0.25	0.44	-0.30	0.50	-0.35	0.52	-0.37
V <sub>STRNA</sub>	0.33	-0.25	0.38	-0.30	0.42	-0.36	0.46	-0.39
V <sub>CG</sub> AC	0.36	-0.21	0.40	-0.26	0.44	-0.28	0.47	-0.32
TR <sub>CG</sub> AC	0.08	-0.06	0.12	-0.09	0.15	-0.10	0.19	-0.13

TABLE 4. SEAWORTHINESS TEST RESULTS IN SEA STATE 2 (29 FEB 1980)  
(CONTINUED)

RUN 8 S, BEAM SEA, SES, APPROX. 29 KNOTS

229S08

	AVERAGE		AVE 1/3		AVE 1/10		MAX	
	PK	TR	PK	TR	PK	TR	PK	TR
PITCH	0.67	-0.60	0.91	-0.80	1.22	-0.93	1.27	-0.94
ROLL	2.01	-1.91	3.47	-3.39	4.54	-4.38	5.91	-4.93
VBOWAC	0.33	-0.26	0.41	-0.33	0.48	-0.41	0.59	-0.50
VSTRNA	0.32	-0.24	0.39	-0.27	0.42	-0.28	0.42	-0.28
VCGAC	0.33	-0.23	0.37	-0.29	0.40	-0.33	0.40	-0.33
TRCGAC	0.05	-0.11	0.09	-0.13	0.14	-0.14	0.19	-0.16

RUN 9 P. QUARTERING SEA, SES, APPROX. 31 KNOTS

229S09

	AVERAGE		AVE 1/3		AVE 1/10		MAX	
	PK	TR	PK	TR	PK	TR	PK	TR
PITCH	0.64	-0.80	0.88	-1.06	1.05	-1.27	1.11	-1.33
ROLL	1.32	-1.38	2.02	-2.56	2.48	-3.52	3.27	-3.86
VBOWAC	0.34	-0.24	0.40	-0.28	0.47	-0.33	0.49	-0.34
VSTRNA	0.31	-0.25	0.37	-0.29	0.44	-0.32	0.44	-0.32
VCGAC	0.33	-0.21	0.37	-0.22	0.37	-0.22	0.37	-0.22
TRCGAC	0.07	-0.08	0.12	-0.11	0.15	-0.14	0.19	-0.19

RUN 10 P. ROW SEA, SES, APPROX. 31 KNOTS

229S10

	AVERAGE		AVE 1/3		AVE 1/10		MAX	
	PK	TR	PK	TR	PK	TR	PK	TR
PITCH	0.62	-0.63	0.90	-0.87	0.91	-1.16	0.91	-1.16
ROLL	1.02	-1.03	1.54	-1.66	1.89	-2.29	2.15	-3.03
VBOWAC	0.40	-0.29	0.52	-0.41	0.63	-0.51	0.90	-0.73
VSTRNA	0.34	-0.28	0.41	-0.36	0.48	-0.44	0.59	-0.53
VCGAC	0.39	-0.25	0.48	-0.33	0.56	-0.39	0.70	-0.49
TRCGAC	0.05	-0.08	0.07	-0.09	0.08	-0.10	0.09	-0.11

TABLE 4. SEAWORTHINESS TEST RESULTS IN SEA STATE 2 (29 FEB 1980)  
(CONTINUED)

RUN 11 HEAD SEA, SES, APPROX. 10 KNOTS 229S11

	AVERAGE		AVE 1/3		AVE 1/10		MAX	
	PK	TR	PK	TR	PK	TR	PK	TR
PITCH	0.68	-0.83	0.93	-1.13	1.14	-1.42	1.46	-1.56
ROLL	0.57	-0.55	0.66	-0.67	0.75	-0.73	0.78	-0.73
VBOWAC	0.29	-0.14	0.46	-0.21	0.69	-0.25	1.14	-0.41
VSTRNA	0.27	-0.13	0.35	-0.23	0.44	-0.35	0.60	-0.55
VCGAC	0.24	-0.10	0.31	-0.14	0.39	-0.17	0.43	-0.19
TRCGAC	-0.00	-0.06	0.01	-0.07	0.01	-0.07	0.01	-0.07

RUN 12 FOLLOWING SEA, SES, APPROX. 10 KNOTS 229S12

	AVERAGE		AVE 1/3		AVE 1/10		MAX	
	PK	TR	PK	TR	PK	TR	PK	TR
PITCH	0.71	-0.68	0.93	-0.84	0.98	-0.98	0.98	-0.98
ROLL	0.56	-0.56	0.62	-0.72	0.68	-0.93	0.68	-0.73
VBOWAC	0.10	0.00	0.12	0.00	0.13	0.00	0.13	0.00
VSTRNA	0.00	-0.00	0.00	-0.00	0.00	-0.00	0.00	-0.00
VCGAC	0.00	-0.00	0.00	-0.00	0.00	-0.00	0.00	-0.00
TRCGAC	-0.00	-0.06	-0.00	-0.06	-0.00	-0.06	-0.00	-0.06

RUN 13 P. BEAM SEA, SES, APPROX. 10 KNOTS 229S13

	AVERAGE		AVE 1/3		AVE 1/10		MAX	
	PK	TR	PK	TR	PK	TR	PK	TR
PITCH	0.61	-0.60	0.76	-0.70	0.83	-0.81	0.83	-0.85
ROLL	1.71	-2.10	2.87	-3.28	3.73	-4.26	5.47	-5.03
VBOWAC	0.12	-0.02	0.14	-0.05	0.17	-0.08	0.21	-0.15
VSTRNA	0.10	-0.03	0.12	-0.04	0.14	-0.06	0.20	-0.09
VCGAC	0.10	-0.01	0.12	-0.03	0.12	-0.05	0.13	-0.07
TRCGAC	0.03	-0.09	0.07	-0.13	0.11	-0.15	0.14	-0.17

RUN 14 S. BOW SEA, SES, APPROX. 10 KNOTS 229S14

	AVERAGE		AVE 1/3		AVE 1/10		MAX	
	PK	TR	PK	TR	PK	TR	PK	TR
PITCH	0.71	-0.77	0.93	-1.11	1.11	-1.37	1.33	-1.61
ROLL	0.67	-0.94	0.99	-1.25	1.24	-1.52	1.46	-1.71
VBOWAC	0.16	-0.05	0.25	-0.14	0.34	-0.19	0.60	-0.26
VSTRNA	0.16	-0.05	0.26	-0.11	0.33	-0.17	0.46	-0.29
VCGAC	0.12	-0.02	0.16	-0.05	0.20	0.09	0.28	-0.16
TRCGAC	0.00	-0.07	0.02	-0.08	0.03	-0.10	0.04	-0.10

TABLE 4. SEAWORTHINESS TEST RESULTS IN SEA STATE 2 (29 FEB 1980)  
(CONTINUED)

RUN 11 HEAD SEA, WPB, APPROX. 10 KNOTS 229W11

	AVERAGE		AVE 1/3		AVE 1/10		MAX	
	PK	TR	PK	TR	PK	TR	PK	TR
PITCH	0.99	-1.11	1.91	-1.96	2.61	-2.45	3.42	-2.98
ROLL	0.83	-0.78	1.47	-1.32	1.80	-1.67	2.10	-2.05
VBOWAC	0.28	-0.33	0.43	-0.54	0.54	-0.69	0.70	-0.88
VSTRNA	0.14	-0.15	0.22	-0.23	0.27	-0.30	0.33	-0.41
VCGAC	0.12	-0.11	0.17	-0.18	0.21	-0.24	0.26	-0.30
TRCGAC	0.05	-0.06	0.05	-0.06	0.06	-0.07	0.06	-0.07

RUN 12 FOLLOWING SEA, WPB, APPROX. 10 KNOTS 229W12

	AVERAGE		AVE 1/3		AVE 1/10		MAX	
	PK	TR	PK	TR	PK	TR	PK	TR
PITCH	0.99	-0.34	1.88	-1.46	2.12	-1.81	2.16	-1.84
ROLL	1.70	-1.69	3.49	-3.04	4.70	-4.07	6.10	-4.35
VBOWAC	0.04	-0.06	0.06	-0.08	0.08	-0.10	0.10	-0.13
VSTRNA	0.01	-0.05	0.02	-0.06	0.03	-0.07	0.05	-0.09
VCGAC	0.03	-0.03	0.04	-0.04	0.05	-0.04	0.05	-0.05
TRCGAC	0.04	-0.05	0.06	-0.08	0.07	-0.11	0.08	-0.14

RUN 13 P. BEAM SEA, WPB, APPROX. 10 KNOTS 229W13

	AVERAGE		AVE 1/3		AVE 1/10		MAX	
	PK	TR	PK	TR	PK	TR	PK	TR
PITCH	-0.07	-2.23	2.17	-3.43	9.17	-4.94	15.69	-14.05
ROLL	3.57	-1.56	15.40	-8.23	27.85	-9.30	34.37	-10.45
VBOWAC	0.15	-0.14	0.24	-0.24	0.31	-0.32	0.44	-0.41
VSTRNA	0.07	-0.11	0.12	-0.16	0.15	-0.21	0.21	-0.28
VCGAC	0.08	-0.08	0.13	-0.13	0.16	-0.17	0.22	-0.25
TRCGAC	0.08	-0.08	0.13	-0.13	0.17	-0.16	0.21	-0.19

RUN 14 S. BOW SEA, WPB, APPROX. 10 KNOTS 229W14

	AVERAGE		AVE 1/3		AVE 1/10		MAX	
	PK	TR	PK	TR	PK	TR	PK	TR
PITCH	0.97	-0.85	1.82	-1.60	2.92	-2.03	16.23	-3.43
ROLL	1.31	-1.07	2.66	-1.82	5.84	-2.40	35.11	-3.22
VBOWAC	0.37	-0.15	0.84	-0.41	2.23	-0.55	14.55	-1.90
VSTRNA	0.19	-0.07	0.42	-0.19	1.08	-0.26	6.74	-0.91
VCGAC	0.17	-0.04	0.35	-0.14	0.87	-0.18	5.31	-0.54
TRCGAC	0.06	-0.04	0.12	-0.07	0.27	-0.08	1.30	-0.13

TABLE 4. SEAWORTHINESS TEST RESULTS IN SEA STATE 2 (29 FEB 1980)  
(CONTINUED)

RUN 15 S. QUARTERING SEA, SES, APPROX. 10 KNOTS

229515

	AVERAGE		AVE 1/3		AVE 1/10		MAX.	
	PK	TR	PK	TR	PK	TR	PK	TR
PITCH	0.59	-0.62	0.73	-0.76	0.81	-0.85	0.81	-0.85
ROLL	0.90	-0.89	1.23	-1.26	1.40	-1.53	1.46	-1.71
VBOWAC	0.04	-0.03	0.05	-0.04	0.05	-0.05	0.07	-0.05
VSTRNA	0.03	-0.03	0.04	-0.03	0.04	-0.03	0.04	-0.04
VCGAC	0.03	-0.02	0.03	-0.02	0.04	-0.02	0.04	-0.02
TRCGAC	0.04	-0.03	0.05	-0.05	0.05	-0.05	0.06	-0.06

RUN 16 HEAD SEA, SES, APPROX. 15 KNOTS

229516

	AVERAGE		AVE 1/3		AVE 1/10		MAX	
	PK	TR	PK	TR	PK	TR	PK	TR
PITCH	0.54	-0.72	0.74	-0.92	0.91	-1.14	1.12	-1.43
ROLL	0.55	-0.51	0.63	-0.59	0.73	-0.63	0.73	-0.63
VBOWAC	0.21	-0.16	0.27	-0.27	0.32	-0.37	0.41	-0.54
VSTRNA	0.27	-0.09	0.41	-0.12	0.52	-0.17	0.69	-0.24
VCGAC	0.18	-0.07	0.22	-0.10	0.27	-0.14	0.32	-0.16
TRCGAC	0.02	-0.06	0.05	-0.07	0.09	-0.07	0.13	-0.08

RUN 17 FOLLOWING SEA, SES, APPROX. 16 KNOTS

229517

	AVERAGE		AVE 1/3		AVE 1/10		MAX	
	PK	TR	PK	TR	PK	TR	PK	TR
PITCH	0.82	-0.85	1.21	-1.23	1.53	-1.43	1.53	-1.43
ROLL	0.60	-0.62	0.76	-0.75	0.83	-0.83	0.83	-0.83
VBOWAC	0.11	-0.01	0.12	-0.03	0.14	-0.06	0.20	-0.13
VSTRNA	0.10	-0.02	0.13	-0.03	0.16	-0.05	0.20	-0.06
VCGAC	0.00	-0.00	0.00	-0.00	0.00	-0.00	0.00	-0.00
TRCGAC	0.02	-0.05	0.05	-0.06	0.08	-0.06	0.08	-0.06

TABLE 4. SEAWORTHINESS TEST RESULTS IN SEA STATE 2 (29 FEB 1980)  
(CONTINUED)

RUN 15 S. QUARTERING SEA, WPB, APPROX. 10 KNOTS

229W15

	AVERAGE		AVE 1/3		AVE 1/10		MAX	
	PK	TR	PK	TR	PK	TR	PK	TR
PITCH	0.73	-0.71	0.97	-1.08	1.11	-1.33	1.14	-1.46
ROLL	1.84	-1.87	3.62	-3.27	4.76	-4.12	6.25	-4.98
VBOWAC	0.06	-0.05	0.09	-0.07	0.13	-0.09	0.29	-0.15
VSTRNA	0.02	-0.05	0.04	-0.06	0.06	-0.07	0.13	-0.07
VCGAC	0.04	-0.02	0.06	-0.04	0.09	-0.04	0.35	-0.06
TRCGAC	0.05	-0.05	0.08	-0.08	0.10	-0.10	0.12	-0.13

RUN 16 HEAD SEA, WPB, APPROX. 15 KNOTS

229W16

	AVERAGE		AVE 1/3		AVE 1/10		MAX	
	PK	TR	PK	TR	PK	TR	PK	TR
PITCH	0.75	-0.86	1.36	-1.48	1.57	-1.74	1.86	-2.05
ROLL	0.87	-0.85	1.70	-1.73	2.31	-2.32	2.64	-2.69
VBOWAC	0.22	-0.22	0.36	-0.38	0.48	-0.52	0.67	-0.90
VSTRNA	0.11	-0.13	0.19	-0.21	0.24	-0.26	0.33	-0.43
VCGAC	0.10	-0.10	0.15	-0.16	0.19	-0.22	0.24	-0.37
TRCGAC	0.03	-0.04	0.05	-0.06	0.07	-0.07	0.07	-0.09

RUN 17 FOLLOWING SEA, WPB, APPROX. 16 KNOTS

229W17

	AVERAGE		AVE 1/3		AVE 1/10		MAX	
	PK	TR	PK	TR	PK	TR	PK	TR
PITCH	0.93	-0.45	1.32	-0.74	1.71	-0.83	1.71	-0.83
ROLL	1.69	-1.87	3.38	-3.88	4.53	-5.04	5.13	-6.15
VBOWAC	0.06	-0.06	0.09	-0.10	0.14	-0.16	0.20	-0.23
VSTRNA	0.04	-0.04	0.06	-0.07	0.08	-0.09	0.13	-0.14
VCGAC	0.04	-0.04	0.06	-0.06	0.08	-0.08	0.10	-0.11
TRCGAC	0.06	-0.04	0.09	-0.07	0.10	-0.09	0.12	-0.10

TABLE 4. SEAWORTHINESS TEST RESULTS IN SEA STATE 2 (29 FEB 1980)  
(CONTINUED)

RUN 18 S. BEAM SEA, SES, APPROX. 16 KNOTS

229518

	AVERAGE		AVE 1/3		AVE 1/10		MAX	
	PK	TR	PK	TR	PK	TR	PK	TR
PITCH	0.46	-0.83	0.69	-0.98	0.98	-1.03	0.98	-1.03
ROLL	1.67	-1.44	2.51	-2.24	3.26	-2.73	4.25	-3.12
VBOWAC	0.13	-0.02	0.16	-0.06	0.18	-0.10	0.28	-0.16
VSTRNA	0.11	-0.02	0.14	-0.04	0.18	-0.07	0.28	-0.10
VCGAC	0.11	-0.01	0.12	-0.03	0.14	-0.04	0.16	-0.09
TRCGAC	0.03	-0.08	0.06	-0.11	0.10	-0.14	0.15	-0.16

RUN 19 P. BOW SEA, SES, APPROX. 16 KNOTS

229519

	AVERAGE		AVE 1/3		AVE 1/10		MAX	
	PK	TR	PK	TR	PK	TR	PK	TR
PITCH	0.62	-0.72	0.83	-1.00	0.94	-1.08	1.03	-1.14
ROLL	1.04	-0.99	1.53	-1.48	1.90	-1.83	2.25	-2.34
VBOWAC	0.17	-0.09	0.24	-0.23	0.30	-0.37	0.44	-0.73
VSTRNA	0.20	-0.06	0.32	-0.12	0.46	-0.16	0.72	-0.28
VCGAC	0.13	-0.03	0.16	-0.06	0.21	-0.12	0.41	-0.32
TRCGAC	0.02	-0.08	0.04	-0.10	0.07	-0.11	0.11	-0.15

RUN 20 S. QUARTERING SEA, SES, APPROX. 16 KNOTS

229520

	AVERAGE		AVE 1/3		AVE 1/10		MAX	
	PK	TR	PK	TR	PK	TR	PK	TR
PITCH	0.77	-0.69	1.09	-0.90	1.48	-0.98	1.48	-0.98
ROLL	0.96	-0.88	1.48	-1.36	1.82	-1.72	2.59	-2.00
VBOWAC	0.06	-0.05	0.07	-0.06	0.07	-0.08	0.08	-0.10
VSTRNA	0.05	-0.05	0.06	-0.06	0.06	-0.06	0.06	-0.06
VCGAC	0.05	-0.05	0.06	-0.05	0.06	-0.05	0.06	-0.05
TRCGAC	0.04	-0.04	0.07	-0.05	0.10	-0.06	0.15	-0.09

TABLE 4. SEAWORTHINESS TEST RESULTS IN SEA STATE 2 (29 FEB 1980)  
(CONTINUED)

RUN 18 S. BEAM SEA, WPB, APPROX. 16 KNOTS

229W18

	AVERAGE		AVE 1/3		AVE 1/10		MAX	
	PK	TR	PK	TR	PK	TR	PK	TR
PITCH	0.73	-0.77	1.03	-1.08	1.37	-1.38	1.63	-1.50
ROLL	3.31	-3.09	5.77	-5.54	7.30	-7.25	8.30	-8.20
VBOWAC	0.09	-0.10	0.15	-0.16	0.19	-0.20	0.28	-0.29
VSTRNA	0.06	-0.07	0.11	-0.12	0.17	-0.15	0.31	-0.22
VCGAC	0.06	-0.06	0.09	-0.09	0.11	-0.12	0.16	-0.16
TRCGAC	0.08	-0.08	0.13	-0.14	0.17	-0.18	0.19	-0.22

RUN 19 P. BOW SEA, WPB, APPROX. 16 KNOTS

229W19

	AVERAGE		AVE 1/3		AVE 1/10		MAX	
	PK	TR	PK	TR	PK	TR	PK	TR
PITCH	0.73	-0.96	1.77	-2.03	2.52	-2.47	2.73	-2.86
ROLL	0.96	-0.95	1.73	-1.73	2.22	-2.15	2.64	-2.78
VBOWAC	0.22	-0.22	0.36	-0.40	0.47	-0.52	0.60	-0.70
VSTRNA	0.16	-0.09	0.32	-0.27	0.42	-0.33	0.50	-0.46
VCGAC	0.10	-0.10	0.14	-0.17	0.17	-0.21	0.20	-0.30
TRCGAC	0.04	-0.04	0.06	-0.06	0.07	-0.08	0.09	-0.09

RUN 20 S. QUARTERING SEA, WPB, APPROX. 16 KNOTS

229W20

	AVERAGE		AVE 1/3		AVE 1/10		MAX	
	PK	TR	PK	TR	PK	TR	PK	TR
PITCH	0.71	-0.82	1.17	-1.53	1.31	-1.80	1.37	-1.86
ROLL	2.27	-2.58	4.76	-4.84	5.77	-6.35	6.69	-7.57
VBOWAC	0.08	-0.04	0.22	-0.13	0.28	-0.14	0.41	-0.20
VSTRNA	0.04	-0.04	0.10	-0.08	0.15	-0.10	0.26	-0.12
VCGAC	0.05	-0.02	0.06	-0.03	0.07	-0.04	0.08	-0.06
TRCGAC	0.07	-0.07	0.11	-0.12	0.14	-0.14	0.15	-0.15

TABLE 5. SEAWORTHINESS TEST RESULTS IN LOW SEA STATE 3 (27 FEB 1980)

RUN 1 HEAD SEA, SES, APPROX. 27 KNOTS

227501

	AVERAGE		AVE 1/3		AVE 1/10		MAX	
	PK	TR	PK	TR	PK	TR	PK	TR
PITCH	0.82	-0.78	1.46	-1.47	1.98	-1.83	2.02	-1.92
ROLL	1.10	-1.24	1.68	-1.95	2.15	-2.50	3.03	-3.27
VBOWAC	0.46	-0.35	0.65	-0.50	0.81	-0.60	1.09	-0.81
VSTRNA	0.38	-0.27	0.49	-0.35	0.61	-0.41	0.76	-0.51
VCGAC	0.42	-0.30	0.56	-0.40	0.68	-0.47	0.91	-0.59
TRCGAC	0.04	-0.09	0.06	-0.10	0.08	-0.11	0.09	-0.11

RUN 2 FOLLOWING SEA, SES, APPROX. 29 KNOTS

227502

	AVERAGE		AVE 1/3		AVE 1/10		MAX	
	PK	TR	PK	TR	PK	TR	PK	TR
PITCH	1.13	-1.30	1.79	-1.92	2.22	-2.30	2.57	-2.96
ROLL	1.22	-1.29	2.16	-2.13	2.96	-2.66	3.56	-3.03
VBOWAC	0.32	-0.29	0.39	-0.39	0.44	-0.48	0.50	-0.57
VSTRNA	0.35	-0.27	0.42	-0.33	0.49	-0.39	0.49	-0.39
VCGAC	0.32	-0.25	0.39	-0.30	0.44	-0.32	0.46	-0.32
TRCGAC	0.03	-0.09	0.05	-0.11	0.05	-0.11	0.06	-0.11

RUN 3 P. BEAM SEA, SES, APPROX. 28 KNOTS

227503

	AVERAGE		AVE 1/3		AVE 1/10		MAX	
	PK	TR	PK	TR	PK	TR	PK	TR
PITCH	1.21	-1.17	1.93	-2.02	2.36	-2.46	2.93	-3.24
ROLL	1.24	-1.40	2.20	-2.23	2.76	-2.86	3.52	-3.96
VBOWAC	0.32	-0.25	0.39	-0.31	0.45	-0.35	0.62	-0.44
VSTRNA	0.32	-0.23	0.34	-0.26	0.37	-0.29	0.37	-0.29
VCGAC	0.34	-0.21	0.40	-0.25	0.44	-0.30	0.46	-0.32
TRCGAC	0.05	-0.09	0.07	-0.11	0.11	-0.12	0.20	-0.13

TABLE 5. SEAWORTHINESS TEST RESULTS IN LOW SEA STATE 3 (27 FEB 1980)  
(CONTINUED)

RUN 4 S. BEAM SEA, SES, APPROX. 29 KNOTS

227S04

	AVERAGE		AVE 1/3		AVE 1/10		MAX	
	PK	TR	PK	TR	PK	TR	PK	TR
FITCH	1.04	-1.06	1.55	-1.65	1.96	-2.14	2.95	-2.77
ROLL	1.28	-1.32	2.03	-2.05	2.55	-2.59	3.91	-3.42
VBOWAC	0.41	-0.35	0.55	-0.50	0.69	-0.62	0.90	-0.83
VSTRNA	0.34	-0.26	0.42	-0.33	0.49	-0.38	0.58	-0.50
VCGAC	0.38	-0.29	0.49	-0.38	0.58	-0.44	0.72	-0.52
TRCGAC	0.03	-0.11	0.04	-0.12	0.06	-0.14	0.09	-0.15

RUN 5 P. BOW SEA, SES, APPROX. 31 KNOTS

227S05

	AVERAGE		AVE 1/3		AVE 1/10		MAX	
	PK	TR	PK	TR	PK	TR	PK	TR
FITCH	0.86	-0.80	1.45	-1.40	1.80	-1.82	2.16	-2.15
ROLL	1.67	-1.74	2.96	-3.09	3.90	-3.97	4.79	-4.64
VBOWAC	0.38	-0.29	0.49	-0.38	0.58	-0.47	0.78	-0.65
VSTRNA	0.35	-0.25	0.42	-0.31	0.47	-0.37	0.49	-0.44
VCGAC	0.37	-0.26	0.45	-0.33	0.52	-0.38	0.62	-0.45
TRCGAC	0.04	-0.10	0.06	-0.13	0.07	-0.15	0.07	-0.18

RUN 6 S. QUARTERING SEA, SES, APPROX. 31 KNOTS

227S06

	AVERAGE		AVE 1/3		AVE 1/10		MAX	
	PK	TR	PK	TR	PK	TR	PK	TR
FITCH	0.97	-1.07	1.42	-1.57	1.79	-1.85	2.00	-2.07
ROLL	1.76	-2.23	2.85	-3.42	3.52	-4.31	4.44	-5.42
VBOWAC	0.36	-0.31	0.46	-0.43	0.54	-0.53	0.75	-0.65
VSTRNA	0.33	-0.25	0.39	-0.31	0.45	-0.39	0.46	-0.46
VCGAC	0.33	-0.26	0.39	-0.33	0.45	-0.36	0.52	-0.38
TRCGAC	0.05	-0.12	0.08	-0.16	0.12	-0.18	0.16	-0.19

TABLE 6. SEAWORTHINESS TEST RESULTS IN LOW SEA STATE 4 (26 FEB 1980)

RUN 1 FOLLOWING SEA, SES, APPROX. 10 KNOTS

226S01

	AVERAGE		AVE 1/3		AVE 1/10		MAX	
	PK	TR	PK	TR	PK	TR	PK	TR
PITCH	1.34	-1.42	2.21	-2.06	2.92	-2.49	3.61	-2.83
ROLL	1.74	-1.84	2.76	-2.90	3.45	-3.85	4.10	-4.74
VBOWAC	0.17	-0.10	0.23	-0.14	0.27	-0.17	0.29	-0.23
VSTRNA	0.11	-0.06	0.15	-0.10	0.18	-0.14	0.23	-0.18
VCGAC	0.10	-0.02	0.12	-0.04	0.14	-0.06	0.15	-0.08
TRCGAC	0.04	-0.09	0.07	-0.11	0.08	-0.13	0.09	-0.16

RUN 2 HEAD SEA, SES, APPROX. 10 KNOTS

226S02

	AVERAGE		AVE 1/3		AVE 1/10		MAX	
	PK	TR	PK	TR	PK	TR	PK	TR
PITCH	1.29	-1.09	2.02	-1.83	2.57	-2.40	3.27	-3.01
ROLL	1.61	-1.62	2.62	-2.53	3.24	-3.07	4.00	-3.47
VBOWAC	0.37	-0.29	0.66	-0.56	1.06	-0.72	2.23	-1.14
VSTRNA	0.32	-0.18	0.55	-0.32	0.77	-0.49	1.03	-0.84
VCGAC	0.21	-0.13	0.31	-0.22	0.45	-0.29	0.80	-0.46
TRCGAC	0.04	-0.09	0.07	-0.12	0.09	-0.14	0.18	-0.17

RUN 3 S. BOW SEA, SES, APPROX. 10 KNOTS

226S03

	AVERAGE		AVE 1/3		AVE 1/10		MAX	
	PK	TR	PK	TR	PK	TR	PK	TR
PITCH	1.17	-1.30	1.65	-1.87	1.81	-2.34	1.86	-2.67
ROLL	2.25	-1.64	3.48	-2.83	4.50	-3.67	5.37	-4.25
VBOWAC	0.19	-0.16	0.27	-0.27	0.34	-0.40	0.54	-0.55
VSTRNA	0.19	-0.11	0.27	-0.17	0.36	-0.24	0.55	-0.51
VCGAC	0.16	-0.09	0.18	-0.12	0.21	-0.16	0.26	-0.22
TRCGAC	0.06	-0.12	0.09	-0.15	0.13	-0.19	0.18	-0.28

TABLE 6. SEAWORTHINESS TEST RESULTS IN LOW SEA STATE 4 (26 FEB 1980)  
(CONTINUED)

RUN 1 FOLLOWING SEA, WPB, APPROX. 10 KNOTS

226W01

	AVERAGE		AVE 1/3		AVE 1/10		MAX	
	PK	TR	PK	TR	PK	TR	PK	TR
PITCH	1.35	-1.35	2.03	-2.19	2.47	-2.69	2.99	-3.58
ROLL	4.68	-4.71	8.03	-7.28	10.09	-9.12	12.35	-10.74
VCGAC	0.07	-0.06	0.08	-0.09	0.10	-0.11	0.11	-0.13
TRCGAC	0.13	-0.12	0.19	-0.18	0.23	-0.22	0.27	-0.27
LNCGAC	0.04	-0.11	0.05	-0.14	0.05	-0.14	0.05	-0.14

RUN 2 HEAD SEA, WPB, APPROX. 10 KNOTS

226W02

	AVERAGE		AVE 1/3		AVE 1/10		MAX	
	PK	TR	PK	TR	PK	TR	PK	TR
PITCH	2.24	-2.30	3.66	-3.54	4.46	-4.27	6.25	-6.36
ROLL	3.63	-3.51	5.85	-5.86	7.26	-7.40	9.57	-10.99
VCGAC	0.07	-0.06	0.08	-0.07	0.09	-0.09	0.12	-0.11
TRCGAC	0.11	-0.11	0.17	-0.16	0.21	-0.21	0.30	-0.30
LNCGAC	0.07	-0.11	0.10	-0.18	0.11	-0.24	0.15	-0.36

RUN 3 S. BOW SEA, WPB, APPROX. 10 KNOTS

226W03

	AVERAGE		AVE 1/3		AVE 1/10		MAX	
	PK	TR	PK	TR	PK	TR	PK	TR
PITCH	1.19	-1.20	1.96	-1.98	2.52	-2.60	3.60	-3.55
ROLL	3.89	-3.99	6.12	-6.92	8.06	-8.85	10.25	-10.79
VCGAC	0.07	-0.05	0.08	-0.07	0.10	-0.11	0.10	-0.11
TRCGAC	0.12	-0.12	0.19	-0.17	0.24	-0.20	0.29	-0.32
LNCGAC	0.06	-0.07	0.07	-0.10	0.08	-0.12	0.10	-0.18

TABLE 6. SEAWORTHINESS TEST RESULTS IN LOW SEA STATE 4 (26 FEB 1980)  
(CONTINUED)

RUN 4 P. QUARTERING SEA, SES, APPROX. 10 KNOTS 226504

	AVERAGE		AVE 1/3		AVE 1/10		MAX	
	PK	TR	PK	TR	PK	TR	PK	TR
PITCH	1.55	-1.79	2.35	-2.61	2.97	-3.11	3.45	-3.69
ROLL	2.06	-2.04	3.28	-3.30	4.18	-4.29	5.32	-5.66
VBOWAC	0.22	-0.15	0.31	-0.26	0.37	-0.32	0.49	-0.44
VSTRNA	0.20	-0.11	0.29	-0.19	0.39	-0.25	0.53	-0.37
VCGAC	0.17	-0.08	0.22	-0.10	0.26	-0.12	0.27	-0.14
TRCGAC	0.06	-0.11	0.09	-0.14	0.12	-0.16	0.14	-0.19

RUN 5 P. BEAM SEA, SES, APPROX. 10 KNOTS 226505

	AVERAGE		AVE 1/3		AVE 1/10		MAX	
	PK	TR	PK	TR	PK	TR	PK	TR
PITCH	1.07	-1.40	1.74	-2.15	2.40	-2.62	2.91	-2.80
ROLL	2.53	-3.09	4.18	-4.82	5.48	-6.18	7.18	-7.28
VBOWAC	0.21	-0.21	0.29	-0.34	0.35	-0.45	0.68	-0.55
VSTRNA	0.24	-0.12	0.35	-0.19	0.44	-0.26	0.58	-0.36
VCGAC	0.15	-0.09	0.17	-0.13	0.18	-0.16	0.19	-0.20
TRCGAC	0.07	-0.13	0.12	-0.17	0.16	-0.19	0.22	-0.22

RUN 6 S. BEAM SEA, SES, APPROX. 15 KNOTS 226506

	AVERAGE		AVE 1/3		AVE 1/10		MAX	
	PK	TR	PK	TR	PK	TR	PK	TR
PITCH	1.67	-1.39	2.78	-2.65	3.38	-3.37	3.66	-4.00
ROLL	3.41	-2.50	5.35	-4.58	6.44	-6.16	6.98	-8.64
VBOWAC	0.19	-0.19	0.26	-0.29	0.31	-0.40	0.37	-0.60
VSTRNA	0.21	-0.09	0.29	-0.13	0.36	-0.17	0.48	-0.30
VCGAC	0.16	-0.09	0.19	-0.12	0.22	-0.14	0.27	-0.16
TRCGAC	0.08	-0.14	0.12	-0.20	0.15	-0.25	0.18	-0.28

RUN 7 HEAD SEA, SES, APPROX. 15 KNOTS 226507

	AVERAGE		AVE 1/3		AVE 1/10		MAX	
	PK	TR	PK	TR	PK	TR	PK	TR
PITCH	1.06	-1.09	1.65	-1.66	2.25	-2.03	2.39	-2.25
ROLL	1.64	-1.78	2.78	-2.87	3.64	-3.55	5.66	-4.69
VBOWAC	0.27	-0.25	0.41	-0.51	0.56	-0.70	0.99	-0.94
VSTRNA	0.33	-0.13	0.54	-0.20	0.73	-0.27	1.03	-0.42
VCGAC	0.19	-0.11	0.26	-0.17	0.36	-0.24	0.68	-0.39
TRCGAC	0.05	-0.11	0.07	-0.14	0.09	-0.17	0.10	-0.18

TABLE 6. SEAWORTHINESS TEST RESULTS IN LOW SEA STATE 4 (26 FEB 1980)  
(CONTINUED)

RUN 4 P. QUARTERING SEA, WPB, APPROX. 10 KNOTS 226W04

	AVERAGE		AVE 1/3		AVE 1/10		MAX	
	PK	TR	PK	TR	PK	TR	PK	TR
PITCH	1.46	-1.45	2.26	-2.25	2.80	-2.74	3.99	-3.53
ROLL	5.84	-5.83	10.45	-9.39	13.48	-11.98	17.68	-14.99
VCGAC	0.07	-0.07	0.09	-0.10	0.10	-0.12	0.13	-0.12
TRCGAC	0.16	-0.14	0.24	-0.24	0.30	-0.30	0.36	-0.36
LNCGAC	0.05	-0.08	0.06	-0.09	0.06	-0.11	0.07	-0.12

RUN 5 P. BEAM SEA, WPB, APPROX. 10 KNOTS 226W05

	AVERAGE		AVE 1/3		AVE 1/10		MAX	
	PK	TR	PK	TR	PK	TR	PK	TR
PITCH	1.81	-1.76	2.88	-2.94	3.62	-3.70	4.82	-5.47
ROLL	6.66	-6.61	11.41	-10.57	15.10	-13.60	22.22	-17.09
VCGAC	0.07	-0.10	0.10	-0.14	0.12	-0.18	0.15	-0.21
TRCGAC	0.15	-0.19	0.24	-0.28	0.32	-0.34	0.46	-0.47
LNCGAC	0.07	-0.09	0.09	-0.12	0.15	-0.14	0.61	-0.16

RUN 6 S. BEAM SEA, WPB, APPROX. 15 KNOTS 226W06

	AVERAGE		AVE 1/3		AVE 1/10		MAX	
	PK	TR	PK	TR	PK	TR	PK	TR
PITCH	1.17	-1.18	2.16	-2.03	2.82	-2.67	3.96	-3.86
ROLL	5.85	-5.84	10.35	-11.22	13.19	-15.69	16.80	-23.39
VCGAC	0.15	-0.17	0.22	-0.25	0.27	-0.32	0.37	-0.37
TRCGAC	0.15	-0.16	0.27	-0.26	0.38	-0.35	0.59	-0.60
LNCGAC	0.06	-0.07	0.08	-0.10	0.10	-0.12	0.12	-0.15

RUN 7 HEAD SEA, WPB, APPROX. 15 KNOTS 226W07

	AVERAGE		AVE 1/3		AVE 1/10		MAX	
	PK	TR	PK	TR	PK	TR	PK	TR
PITCH	1.19	-1.20	1.87	-1.88	2.29	-2.52	2.69	-3.92
ROLL	2.82	-2.57	5.11	-5.02	6.72	-7.49	7.67	-9.77
VCGAC	0.16	-0.18	0.23	-0.28	0.27	-0.34	0.33	-0.40
TRCGAC	0.09	-0.09	0.14	-0.14	0.19	-0.17	0.23	-0.21
LNCGAC	0.06	-0.09	0.09	-0.12	0.13	-0.16	0.62	-0.21

TABLE 6. SEAWORTHINESS TEST RESULTS IN LOW SEA STATE 4 (26 FEB 1980)  
(CONTINUED)

RUN 8 P. QUARTERING SEA, SES, APPROX. 17 KNOTS 226508

	AVERAGE		AVE 1/3		AVE 1/10		MAX	
	PK	TR	PK	TR	PK	TR	PK	TR
PITCH	1.56	-1.51	2.84	-2.64	3.57	-3.54	4.59	-5.68
ROLL	2.11	-2.92	3.59	-4.65	5.21	-5.84	7.13	-7.91
VBOWAC	0.27	-0.31	0.39	-0.54	0.49	-0.76	0.57	-1.16
VSTRNA	0.26	-0.12	0.43	-0.17	0.57	-0.21	0.70	-0.26
VCGAC	0.17	-0.11	0.22	-0.16	0.28	-0.22	0.38	-0.29
TRCGAC	0.05	-0.12	0.08	-0.16	0.11	-0.20	0.17	-0.23

RUN 9 S. BOW SEA, SES, APPROX. 16 KNOTS 226509

	AVERAGE		AVE 1/3		AVE 1/10		MAX	
	PK	TR	PK	TR	PK	TR	PK	TR
PITCH	1.77	-1.92	2.96	-3.29	3.91	-4.48	4.79	-6.35
ROLL	1.96	-1.65	3.34	-2.83	4.48	-3.71	6.40	-4.30
VBOWAC	0.26	-0.24	0.39	-0.45	0.49	-0.63	1.12	-0.98
VSTRNA	0.24	-0.13	0.38	-0.21	0.53	-0.29	0.81	-0.45
VCGAC	0.17	-0.11	0.22	-0.17	0.26	-0.21	0.37	-0.24
TRCGAC	0.06	-0.13	0.10	-0.18	0.12	-0.22	0.16	-0.27

RUN 10 FOLLOWING SEA, SES, APPROX. 17 KNOTS 226510

	AVERAGE		AVE 1/3		AVE 1/10		MAX	
	PK	TR	PK	TR	PK	TR	PK	TR
PITCH	1.17	-1.19	2.14	-2.27	2.60	-3.09	2.80	-4.07
ROLL	2.98	-3.13	4.98	-4.87	6.24	-6.11	7.18	-6.84
VBOWAC	0.18	-0.15	0.24	-0.24	0.30	-0.34	0.42	-0.73
VSTRNA	0.17	-0.09	0.25	-0.12	0.37	-0.16	0.52	-0.23
VCGAC	0.15	-0.09	0.18	-0.13	0.21	-0.16	0.22	-0.17
TRCGAC	0.06	-0.12	0.09	-0.15	0.12	-0.17	0.15	-0.19

TABLE 6. SEAWORTHINESS TEST RESULTS IN LOW SEA STATE 4 (26 FEB 1980)  
(CONTINUED)

RUN 8 P. QUARTERING SEA, WPB, APPROX. 17 KNOTS

226W08

	AVERAGE		AVE 1/3		AVE 1/10		MAX	
	PK	TR	PK	TR	PK	TR	PK	TR
PITCH	1.49	-1.53	2.52	-2.58	3.08	-3.44	3.69	-4.65
ROLL	5.22	-5.35	11.60	-10.37	15.79	-14.17	22.17	-18.41
VCGAC	0.14	-0.15	0.21	-0.23	0.26	-0.29	0.37	-0.37
TRCGAC	0.15	-0.13	0.25	-0.25	0.34	-0.35	0.46	-0.44
LNCGAC	0.12	-0.01	0.13	-0.03	0.14	-0.06	0.15	-0.09

RUN 9 S. BOW SEA, WPB, APPROX. 16 KNOTS

226W09

	AVERAGE		AVE 1/3		AVE 1/10		MAX	
	PK	TR	PK	TR	PK	TR	PK	TR
PITCH	1.40	-1.54	2.39	-2.74	3.00	-3.52	4.51	-4.56
ROLL	3.33	-3.55	6.84	-7.30	8.73	-10.17	10.01	-13.57
VCGAC	0.19	-0.20	0.28	-0.32	0.34	-0.42	0.47	-0.59
TRCGAC	0.11	-0.12	0.21	-0.19	0.29	-0.24	0.37	-0.28
LNCGAC	0.06	-0.09	0.09	-0.13	0.10	-0.17	0.13	-0.23

RUN 10 FOLLOWING SEA, WPB, APPROX. 17 KNOTS

226W10

	AVERAGE		AVE 1/3		AVE 1/10		MAX	
	PK	TR	PK	TR	PK	TR	PK	TR
PITCH	1.19	-1.17	2.07	-1.96	2.75	-2.64	3.61	-3.53
ROLL	5.52	-5.11	9.93	-9.80	12.21	-14.08	14.79	-21.09
VCGAC	0.11	-0.12	0.17	-0.18	0.22	-0.24	0.28	-0.33
TRCGAC	0.13	-0.14	0.23	-0.22	0.33	-0.26	0.45	-0.38
LNCGAC	0.06	-0.07	0.08	-0.09	0.08	-0.10	0.08	-0.10

TABLE 7. SEAWORTHINESS TEST RESULTS IN SEA STATE 4 (13 MAR 1980)

RUN 1 HEAD SEA, SES, APPROX. 10 KNOTS

313S01

	AVERAGE		AVE 1/3		AVE 1/10		MAX	
	PK	TR	PK	TR	PK	TR	PK	TR
FITCH	3.20	-3.20	5.46	-5.30	7.06	-6.86	10.17	-8.24
ROLL	2.56	-2.49	4.16	-4.08	5.35	-5.16	6.20	-6.93
VEOWAC	0.34	-0.27	0.66	-0.49	1.07	-0.65	2.56	-1.03
VSTRNA	0.21	-0.12	0.44	-0.28	0.61	-0.46	0.92	-1.02
VCGAC	0.17	-0.09	0.28	-0.22	0.39	-0.33	0.79	-0.59
TRCGAC	0.06	-0.11	0.09	-0.14	0.11	-0.17	0.12	-0.19
LNCGAC	0.06	-0.05	0.09	-0.07	0.11	-0.09	0.17	-0.11

RUN 2 S. BEAM SEA, SES, APPROX. 10 KNOTS

313S02

	AVERAGE		AVE 1/3		AVE 1/10		MAX	
	PK	TR	PK	TR	PK	TR	PK	TR
FITCH	1.76	-1.76	2.87	-3.04	3.78	-3.98	4.09	-4.33
ROLL	3.47	-3.72	7.46	-7.18	10.09	-9.29	14.60	-13.09
VEOWAC	0.20	-0.16	0.27	-0.26	0.33	-0.32	0.37	-0.46
VSTRNA	0.15	-0.07	0.23	-0.15	0.31	-0.20	0.42	-0.32
VCGAC	0.13	-0.05	0.17	-0.10	0.20	-0.14	0.24	-0.20
TRCGAC	0.06	-0.12	0.09	-0.17	0.12	-0.20	0.14	-0.23
LNCGAC	0.03	-0.03	0.04	-0.04	0.04	-0.05	0.04	-0.05

RUN 3 FOLLOWING SEA, SES, APPROX. 10 KNOTS

313S03

	AVERAGE		AVE 1/3		AVE 1/10		MAX	
	PK	TR	PK	TR	PK	TR	PK	TR
FITCH	2.41	-2.46	3.74	-3.83	4.70	-4.59	5.00	-5.47
ROLL	1.92	-1.98	3.25	-3.45	4.61	-4.65	5.57	-7.08
VEOWAC	0.16	-0.08	0.20	-0.12	0.21	-0.16	0.21	-0.16
VSTRNA	0.12	-0.03	0.16	-0.06	0.21	-0.09	0.33	-0.12
VCGAC	0.11	-0.00	0.12	-0.02	0.13	-0.03	0.13	-0.03
TRCGAC	0.04	-0.10	0.05	-0.12	0.07	-0.13	0.07	-0.16
LNCGAC	0.02	-0.03	0.02	-0.04	0.02	-0.04	0.02	-0.04

TABLE 7. SEAWORTHINESS TEST RESULTS IN SEA STATE 4 (13 MAR 1980)  
(CONTINUED)

RUN 1 3/13/80 HEAD SEA, WPB, APPROX. 10 KNOTS

313W01

	AVERAGE		AVE 1/3		AVE 1/10		MAX	
	PK	TR	PK	TR	PK	TR	PK	TR
PITCH	2.78	-2.49	4.30	-4.14	5.39	-5.30	6.80	-7.42
ROLL	5.02	-5.00	8.00	-8.01	10.13	-10.32	12.11	-12.40
VBOWAC	0.41	-0.47	0.67	-0.73	0.90	-0.89	1.22	-1.04
VSTRNA	0.28	-0.26	0.40	-0.42	0.49	-0.55	0.59	-0.78
VCGAC	0.19	-0.23	0.28	-0.34	0.35	-0.44	0.42	0.58
TRCGAC	0.11	-0.15	0.18	-0.21	0.24	-0.26	0.29	-0.30
LNCGAC	0.04	-0.12	0.06	-0.16	0.07	-0.22	0.09	-0.26

RUN 2 S. BEAM SEA, WPB, APPROX. 10 KNOTS

313W02

	AVERAGE		AVE 1/3		AVE 1/10		MAX	
	PK	TR	PK	TR	PK	TR	PK	TR
PITCH	2.28	-0.31	3.29	-1.24	3.80	-1.91	4.18	-2.98
ROLL	5.39	-7.72	10.59	-12.85	14.01	-16.55	15.77	-18.90
VBOWAC	0.24	-0.33	0.38	-0.49	0.49	-0.62	0.65	-0.76
VSTRNA	0.18	-0.18	0.25	-0.26	0.31	-0.30	0.42	-0.42
VCGAC	0.13	-0.17	0.18	-0.23	0.23	-0.27	0.28	0.33
TRCGAC	0.12	-0.14	0.21	-0.24	0.30	-0.33	0.34	-0.37
LNCGAC	0.02	-0.11	0.03	-0.12	0.04	-0.13	0.05	-0.15

RUN 3 FOLLOWING SEA, WPB, APPROX. 10 KNOTS

313W03

	AVERAGE		AVE 1/3		AVE 1/10		MAX	
	PK	TR	PK	TR	PK	TR	PK	TR
PITCH	1.76	-2.00	2.56	-2.94	3.30	-3.77	3.61	-3.82
ROLL	4.17	-4.18	7.68	-7.20	9.84	-9.19	11.62	-10.16
VBOWAC	0.13	-0.10	0.16	-0.13	0.17	-0.15	0.18	-0.18
VSTRNA	0.07	-0.07	0.10	-0.08	0.12	-0.11	0.15	-0.11
VCGAC	0.05	-0.08	0.07	-0.10	0.09	-0.12	0.11	-0.12
TRCGAC	0.07	0.14	0.12	0.20	0.14	-0.23	0.16	-0.25
LNCGAC	0.00	-0.00	0.00	-0.00	0.00	-0.00	0.00	-0.00

TABLE 7. SEAWORTHINESS TEST RESULTS IN SEA STATE 4 (13 MAR 1980)  
(CONTINUED)

RUN 4 P. BOW SEA, SES, APPROX. 10 KNOTS 313S04

	AVERAGE		AVE 1/3		AVE 1/10		MAX	
	PK	TR	PK	TR	PK	TR	PK	TR
PITCH	3.34	-3.40	5.80	-5.80	8.12	-7.47	10.64	-8.92
ROLL	3.38	-3.38	5.63	-5.37	7.17	-6.57	7.81	-7.23
VBOWAC	0.31	-0.24	0.54	-0.45	0.83	-0.60	1.56	-0.75
VSTRNA	0.20	-0.09	0.39	-0.25	0.52	-0.38	0.75	-0.74
VCGAC	0.15	-0.08	0.24	-0.20	0.30	-0.29	0.40	-0.39
TRCGAC	0.06	-0.11	0.10	-0.14	0.13	-0.16	0.17	-0.17
LNCGAC	0.06	-0.05	0.09	-0.07	0.14	-0.09	0.26	-0.10

RUN 5 P. QUARTERING SEA, SES, APPROX. 10 KNOTS 313S05

	AVERAGE		AVE 1/3		AVE 1/10		MAX	
	PK	TR	PK	TR	PK	TR	PK	TR
PITCH	2.62	-2.63	3.94	-3.76	4.72	-4.78	4.75	-5.84
ROLL	3.08	-2.84	5.51	-4.95	7.17	-6.34	7.91	-7.71
VBOWAC	0.16	-0.09	0.20	-0.13	0.22	-0.17	0.23	-0.23
VSTRNA	0.11	-0.03	0.15	-0.07	0.17	-0.10	0.18	-0.15
VCGAC	0.12	-0.03	0.14	-0.05	0.15	-0.07	0.16	-0.07
TRCGAC	0.06	-0.10	0.09	-0.12	0.12	-0.14	0.16	-0.16
LNCGAC	0.03	-0.03	0.03	-0.03	0.03	-0.03	0.03	-0.03

RUN 6 HEAD SEA, SES, APPROX. 17 KNOTS 313S06

	AVERAGE		AVE 1/3		AVE 1/10		MAX	
	PK	TR	PK	TR	PK	TR	PK	TR
PITCH	3.46	-3.51	5.29	-5.39	6.57	-6.51	9.16	-8.45
ROLL	2.74	-2.95	4.07	-4.58	5.01	-5.64	5.91	-6.98
VBOWAC	0.34	-0.39	0.61	-0.80	0.80	-1.11	1.09	-1.61
VSTRNA	0.26	-0.08	0.53	-0.25	0.78	-0.37	1.23	-0.64
VCGAC	0.18	-0.06	0.29	-0.20	0.37	-0.32	0.59	-0.59
TRCGAC	0.06	-0.11	0.10	-0.15	0.17	-0.18	0.14	-0.19
LNCGAC	0.11	-0.05	0.20	-0.09	0.30	-0.12	0.45	-0.17

RUN 7 S. BEAM SEA, SES, APPROX. 17 KNOTS 313S07

	AVERAGE		AVE 1/3		AVE 1/10		MAX	
	PK	TR	PK	TR	PK	TR	PK	TR
PITCH	1.82	-1.71	3.37	-3.27	4.38	-4.17	5.66	-5.86
ROLL	3.60	-3.46	6.07	-6.15	7.59	-7.37	9.23	-9.62
VBOWAC	0.23	-0.21	0.35	-0.37	0.43	-0.52	0.57	-0.76
VSTRNA	0.15	-0.04	0.25	-0.11	0.34	-0.16	0.60	-0.20
VCGAC	0.13	-0.04	0.20	-0.10	0.23	-0.14	0.30	-0.24
TRCGAC	0.07	-0.11	0.09	-0.16	0.11	-0.19	0.12	-0.22
LNCGAC	0.11	-0.04	0.23	-0.06	0.32	-0.08	0.44	-0.16

TABLE 7. SEAWORTHINESS TEST RESULTS IN SEA STATE 4 (13 MAR 1980)  
(CONTINUED)

RUN 4 P. BOW SEA, WPB, APPROX. 10 KNOTS 313W04

	AVERAGE		AVE 1/3		AVE 1/10		MAX	
	PK	TR	PK	TR	PK	TR	PK	TR
PITCH	2.48	-2.77	4.07	-4.50	5.11	-5.77	6.01	-7.41
ROLL	6.93	-6.91	11.58	-10.98	15.12	-14.54	20.95	-16.99
VBOWAC	0.36	-0.36	0.59	-0.57	0.83	-0.78	1.16	-1.03
VSTRNA	0.20	-0.21	0.32	-0.36	0.41	-0.48	0.47	-0.59
VCGAC	0.13	-0.19	0.23	-0.31	0.31	-0.42	0.42	-0.59
TRCGAC	0.11	-0.19	0.19	-0.28	0.25	-0.36	0.41	-0.44
LNCGAC	0.03	-0.12	0.04	-0.16	0.06	-0.19	0.07	-0.21

RUN 5 P. QUARTERING SEA, WPB, APPROX. 10 KNOTS 313W05

	AVERAGE		AVE 1/3		AVE 1/10		MAX	
	PK	TR	PK	TR	PK	TR	PK	TR
PITCH	1.72	-1.03	2.49	-1.82	3.05	-2.11	3.43	-2.62
ROLL	4.76	-6.02	9.10	-9.91	11.94	-12.14	13.67	-16.60
VBOWAC	0.20	-0.17	0.27	-0.24	0.33	-0.31	0.49	-0.39
VSTRNA	0.10	-0.09	0.15	-0.14	0.19	-0.17	0.23	-0.20
VCGAC	0.08	-0.11	0.12	-0.15	0.16	-0.20	0.24	-0.23
TRCGAC	0.09	-0.16	0.16	-0.22	0.21	-0.27	0.25	-0.30
LNCGAC	0.00	-0.00	0.00	-0.00	0.00	-0.00	0.00	-0.00

RUN 6 HEAD SEA, WPB, APPROX. 17 KNOTS 313W06

	AVERAGE		AVE 1/3		AVE 1/10		MAX	
	PK	TR	PK	TR	PK	TR	PK	TR
PITCH	2.51	-2.99	4.27	-4.59	5.39	-5.86	6.22	-7.41
ROLL	4.29	-4.38	7.00	-7.46	9.02	-9.79	11.43	-10.99
VBOWAC	0.57	-0.50	0.94	-0.85	1.23	-1.02	1.60	-1.22
VSTRNA	0.29	-0.27	0.47	-0.48	0.60	-0.64	0.73	-1.12
VCGAC	0.23	-0.28	0.38	-0.47	0.49	-0.59	0.60	-0.89
TRCGAC	0.11	-0.14	0.17	-0.21	0.23	-0.25	0.33	-0.29
LNCGAC	0.12	-0.06	0.14	-0.12	0.17	-0.19	0.21	-0.25

RUN 7 S. BEAM SEA, WPB, APPROX. 17 KNOTS 313W07

	AVERAGE		AVE 1/3		AVE 1/10		MAX	
	PK	TR	PK	TR	PK	TR	PK	TR
PITCH	1.70	-0.92	2.76	-1.96	3.29	-2.67	3.61	-3.99
ROLL	5.73	-5.49	10.83	-10.52	13.95	-14.22	17.09	-18.75
VBOWAC	0.29	-0.31	0.45	-0.48	0.58	-0.64	0.73	-0.88
VSTRNA	0.14	-0.19	0.23	-0.29	0.30	-0.38	0.40	-0.53
VCGAC	0.12	-0.18	0.20	-0.28	0.26	-0.35	0.34	-0.51
TRCGAC	0.14	-0.13	0.24	-0.21	0.31	-0.26	0.39	-0.32
LNCGAC	0.03	-0.10	0.04	-0.12	0.05	-0.13	0.06	-0.14

TABLE 7. SEAWORTHINESS TEST RESULTS IN SEA STATE 4 (13 MAR 1980)  
(CONTINUED)

RUN 8 FOLLOWING SEA, SES, APPROX. 19 KNOTS

313508

	AVERAGE		AVE 1/3		AVE 1/10		MAX	
	PK	TR	PK	TR	PK	TR	PK	TR
PITCH	2.24	-2.66	4.03	-4.60	4.75	-5.48	5.32	-6.18
ROLL	1.64	-1.98	3.24	-3.55	4.25	-4.56	4.64	-5.18
VROWAC	0.16	-0.08	0.19	-0.11	0.21	-0.15	0.21	-0.18
VSTRNA	0.11	-0.02	0.14	-0.05	0.17	-0.07	0.20	-0.13
VCGAC	0.11	-0.01	0.13	-0.03	0.14	-0.06	0.17	-0.08
TRCGAC	0.05	-0.10	0.08	-0.12	0.11	-0.15	0.11	-0.15
LNCGAC	0.13	-0.03	0.25	-0.05	0.39	-0.07	0.48	-0.08

RUN 9 P. BOW SEA, SES, APPROX. 17 KNOTS

313509

	AVERAGE		AVE 1/3		AVE 1/10		MAX	
	PK	TR	PK	TR	PK	TR	PK	TR
PITCH	3.28	-3.28	5.34	-5.25	6.67	-7.10	7.86	-9.31
ROLL	3.54	.33	5.80	-5.60	7.53	-7.21	10.25	-9.96
VROWAC	0.31	-0.34	0.56	-0.69	0.74	-0.94	1.38	-1.37
VSTRNA	0.22	-0.08	0.46	-0.25	0.69	-0.37	1.04	-0.57
VCGAC	0.17	-0.06	0.28	-0.20	0.36	-0.33	0.55	-0.62
TRCGAC	0.07	-0.11	0.12	-0.15	0.15	-0.19	0.17	-0.25
LNCGAC	0.09	-0.05	0.18	-0.08	0.29	-0.11	0.45	-0.14

RUN 10 P. QUARTERING SEA, SES, APPROX. 18 KNOTS

313510

	AVERAGE		AVE 1/3		AVE 1/10		MAX	
	PK	TR	PK	TR	PK	TR	PK	TR
PITCH	1.83	-1.67	3.48	-3.18	4.37	-3.84	5.49	-4.10
ROLL	3.11	-3.06	5.57	-5.32	6.93	-7.02	9.13	-9.33
VROWAC	0.18	-0.11	0.24	-0.16	0.28	-0.22	0.34	-0.29
VSTRNA	0.13	-0.03	0.17	-0.07	0.20	-0.09	0.28	-0.11
VCGAC	0.13	-0.03	0.16	-0.06	0.18	-0.09	0.20	-0.13
TRCGAC	0.06	-0.11	0.10	-0.14	0.13	-0.17	0.16	-0.21
LNCGAC	0.09	-0.03	0.19	-0.05	0.30	-0.06	0.46	-0.08

TABLE 7. SEAWORTHINESS TEST RESULTS IN SEA STATE 4 (13 MAR 1980)  
(CONTINUED)

RUN 8 FOLLOWING SEA, WPB, APPROX. 17 KNOTS

313W08

	AVERAGE		AVE 1/3		AVE 1/10		MAX	
	PK	TR	PK	TR	PK	TR	PK	TR
PITCH	1.94	-2.35	3.46	-4.12	4.04	-5.32	4.05	-6.48
ROLL	4.76	-5.83	11.62	-10.84	14.96	-14.71	17.97	-17.14
VBOUAC	0.10	-0.14	0.13	-0.16	0.16	-0.17	0.20	-0.18
VSTRNA	0.04	-0.09	0.06	-0.12	0.07	-0.14	0.10	-0.17
VCGAC	0.03	-0.10	0.05	-0.12	0.06	-0.14	0.06	-0.15
TRCGAC	0.10	-0.18	0.19	-0.30	0.26	-0.34	0.31	-0.41
LNGCAG	0.02	-0.16	0.02	-0.16	0.02	-0.16	0.02	-0.16

RUN 9 P. BOW SEA, WPB, APPROX. 17 KNOTS

313W09

	AVERAGE		AVE 1/3		AVE 1/10		MAX	
	PK	TR	PK	TR	PK	TR	PK	TR
PITCH	2.17	-2.24	3.75	-3.73	4.88	-4.41	6.05	-5.32
ROLL	5.75	-6.17	9.84	-10.33	12.95	-13.62	14.60	-16.11
VBOUAC	0.47	-0.41	0.76	-0.69	0.99	-0.89	1.32	-1.09
VSTRNA	0.26	-0.22	0.41	-0.38	0.53	-0.50	0.68	-0.68
VCGAC	0.20	-0.24	0.32	-0.38	0.41	-0.49	0.46	-0.67
TRCGAC	0.10	-0.18	0.19	-0.27	0.24	-0.33	0.26	-0.42
LNGCAG	0.08	-0.09	0.11	-0.13	0.14	-0.17	0.16	-0.20

RUN 10 P. QUARTERING SEA, WPB, APPROX. 17 KNOTS

313W10

	AVERAGE		AVE 1/3		AVE 1/10		MAX	
	PK	TR	PK	TR	PK	TR	PK	TR
PITCH	1.67	-1.13	2.92	-2.07	3.57	-2.55	3.91	-2.77
ROLL	4.48	-6.57	10.78	-11.88	15.38	-15.35	18.75	-17.53
VBOUAC	0.21	-0.20	0.32	-0.29	0.41	-0.37	0.57	-0.47
VSTRNA	0.12	-0.13	0.13	-0.20	0.23	-0.25	0.35	-0.38
VCGAC	0.09	-0.15	0.15	-0.21	0.20	-0.25	0.32	-0.32
TRCGAC	0.09	-0.19	0.17	-0.30	0.22	-0.40	0.28	-0.50
LNGCAG	0.03	-0.10	0.04	-0.11	0.04	-0.12	0.04	-0.12

TABLE 7. SEAWORTHINESS TEST RESULTS IN SEA STATE 4 (13 MAR 1980)  
(CONTINUED)

RUN 11 HEAD SEA, SES, APPROX. 26 KNOTS 313S11

	AVERAGE		AVE 1/3		AVE 1/10		MAX	
	PK	TR	PK	TR	PK	TR	PK	TR
PITCH	3.66	-3.38	5.48	-5.62	6.71	-7.04	9.51	-8.07
ROLL	3.08	-2.92	4.67	-4.61	5.76	-5.89	6.59	-7.81
VBOWAC	0.45	-0.24	0.84	-0.64	1.23	-0.95	2.21	-1.30
VSTRNA	0.26	-0.17	0.44	-0.34	0.57	-0.49	0.93	-0.83
VCGAC	0.32	-0.18	0.51	-0.36	0.72	-0.48	1.47	-0.69
TRCGAC	0.08	-0.11	0.12	-0.16	0.15	-0.20	0.18	-0.27
LNCGAC	0.06	-0.08	0.12	-0.10	0.18	-0.12	0.37	-0.13

RUN 12 S. BEAM SEA, SES, APPROX. 29 KNOTS 313S12

	AVERAGE		AVE 1/3		AVE 1/10		MAX	
	PK	TR	PK	TR	PK	TR	PK	TR
PITCH	1.96	-1.34	3.77	-3.38	4.84	-5.18	6.02	-6.04
ROLL	3.77	-3.66	6.95	-6.82	9.27	-8.78	12.21	-9.42
VBOWAC	0.31	-0.22	0.49	-0.41	0.65	-0.54	1.06	-0.72
VSTRNA	0.25	-0.16	0.35	-0.26	0.45	-0.35	0.63	-0.51
VCGAC	0.27	-0.16	0.37	-0.27	0.46	-0.34	0.68	-0.42
TRCGAC	0.08	-0.12	0.15	-0.18	0.22	-0.22	0.41	-0.31
LNCGAC	0.07	-0.05	0.15	-0.08	0.22	-0.10	0.52	-0.15

RUN 14 P. QUARTERING SEA, SES, APPROX. 28 KNOTS 313S14

	AVERAGE		AVE 1/3		AVE 1/10		MAX	
	PK	TR	PK	TR	PK	TR	PK	TR
PITCH	1.49	-1.53	3.09	-3.23	4.06	-4.39	5.06	-5.71
ROLL	3.00	-3.11	5.78	-5.73	7.57	-7.66	9.47	-11.18
VBOWAC	0.25	-0.19	0.38	-0.33	0.50	-0.44	0.85	-0.81
VSTRNA	0.24	-0.15	0.34	-0.25	0.45	-0.33	0.73	-0.54
VCGAC	0.25	-0.15	0.35	-0.24	0.45	-0.30	0.62	-0.40
TRCGAC	0.06	-0.12	0.13	-0.18	0.20	-0.22	0.27	-0.25
LNCGAC	0.04	-0.06	0.09	-0.08	0.14	-0.10	0.23	-0.13

TABLE 7. SEAWORTHINESS TEST RESULTS IN SEA STATE 4 (13 MAR 1980)  
(CONTINUED)

RUN 15 P. BOW SEA, SES, APPROX. 27 KNOTS

313S15

	AVERAGE		AVE 1/3		AVE 1/10		MAX	
	PK	TR	PK	TR	PK	TR	PK	TR
PITCH	3.53	-3.13	5.37	-5.22	6.71	-6.30	7.62	-7.13
ROLL	3.14	-3.13	5.25	-5.15	6.45	-6.41	6.98	-7.42
V <sub>BOWAC</sub>	0.45	-0.30	0.79	-0.65	1.06	-0.92	1.86	-1.20
V <sub>STRNA</sub>	0.28	-0.19	0.44	-0.34	0.57	-0.45	0.72	-0.71
V <sub>CGAC</sub>	0.33	-0.19	0.49	-0.36	0.62	-0.45	0.94	-0.59
T <sub>RCGAC</sub>	0.07	-0.12	0.12	-0.16	0.15	-0.19	0.28	-0.24
L <sub>NCGAC</sub>	0.05	-0.08	0.11	-0.11	0.16	-0.12	0.23	-0.13

RUN 16 FOLLOWING SEA, SES, APPROX. 29 KNOTS

313S16

	AVERAGE		AVE 1/3		AVE 1/10		MAX	
	PK	TR	PK	TR	PK	TR	PK	TR
PITCH	1.68	-1.86	3.33	-3.91	4.32	-4.81	5.14	-5.26
ROLL	2.20	-2.08	4.23	-3.72	5.37	-4.67	7.37	-5.32
V <sub>BOWAC</sub>	0.24	-0.16	0.35	-0.25	0.45	-0.33	0.62	-0.52
V <sub>STRNA</sub>	0.25	-0.14	0.35	-0.25	0.44	-0.35	0.64	-0.55
V <sub>CGAC</sub>	0.26	-0.13	0.37	-0.21	0.47	-0.29	0.68	-0.39
T <sub>RCGAC</sub>	0.07	-0.10	0.11	-0.14	0.14	-0.17	0.18	-0.23
L <sub>NCGAC</sub>	0.05	-0.06	0.11	-0.08	0.23	-0.09	0.86	-0.09

RUN 17 FOLLOWING SEA, SES, DIW, 0 KNOTS, STERN TO THE SEA

313S18

	AVERAGE		AVE 1/3		AVE 1/10		MAX	
	PK	TR	PK	TR	PK	TR	PK	TR
PITCH	1.33	-4.31	3.15	-5.89	4.28	-7.01	4.87	-7.70
ROLL	2.72	-2.76	4.37	-4.45	5.68	-5.60	6.45	-6.45
V <sub>BOWAC</sub>	0.14	-0.05	0.21	-0.12	0.27	-0.17	0.42	-0.26
V <sub>STRNA</sub>	0.13	-0.07	0.20	-0.14	0.25	-0.19	0.36	-0.33
V <sub>CGAC</sub>	0.11	-0.03	0.15	-0.06	0.17	-0.08	0.21	-0.10
T <sub>RCGAC</sub>	0.05	-0.11	0.06	-0.14	0.08	-0.16	0.08	-0.20
L <sub>NCGAC</sub>	0.04	-0.04	0.05	-0.05	0.05	-0.06	0.06	-0.06

SIGNIFICANT PITCH-DOWN ANGLE AMPLITUDE  
DEGREES

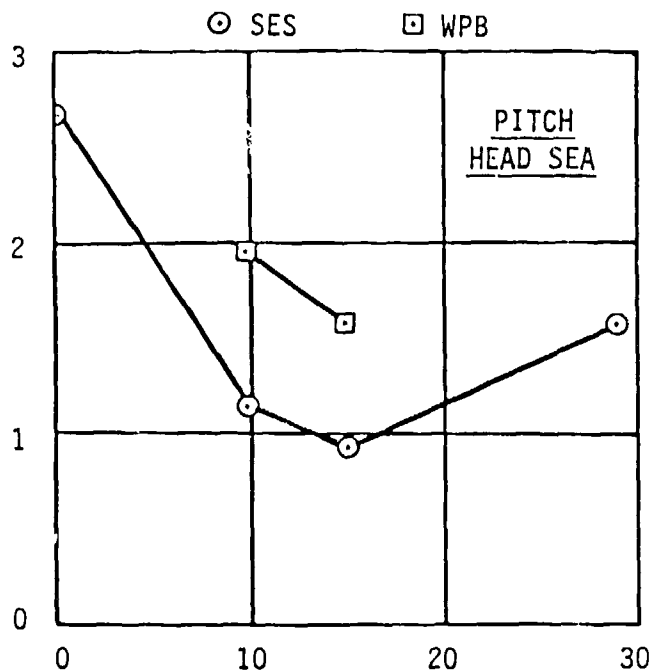

SEA STATE 2  
29 FEB 1980

SIGNIFICANT ROLL ANGLE AMPLITUDE  
DEGREES

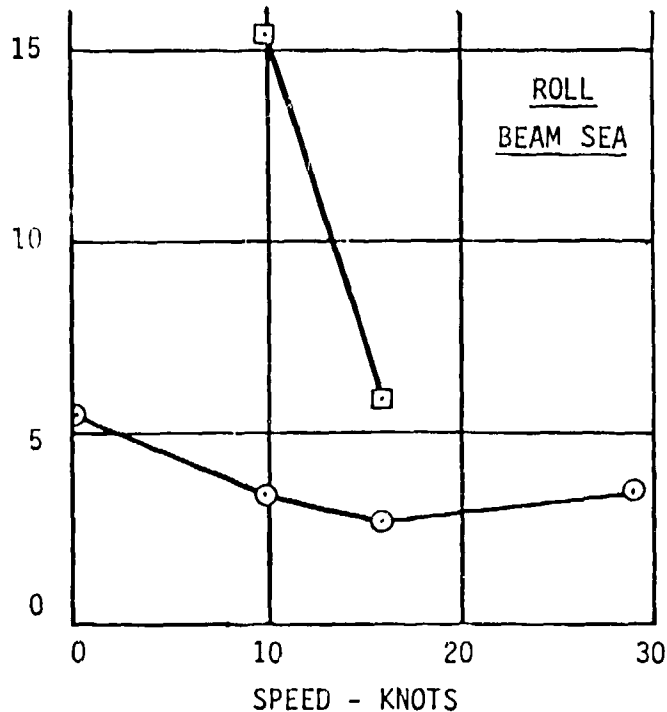

(a) Pitch and Roll in Sea State 2

FIGURE 7. COMPARISON OF SEAWORTHINESS RESULTS FOR VARIOUS  
SEA STATES AND HEADINGS

SIGNIFICANT ACCELERATION AMPLITUDE

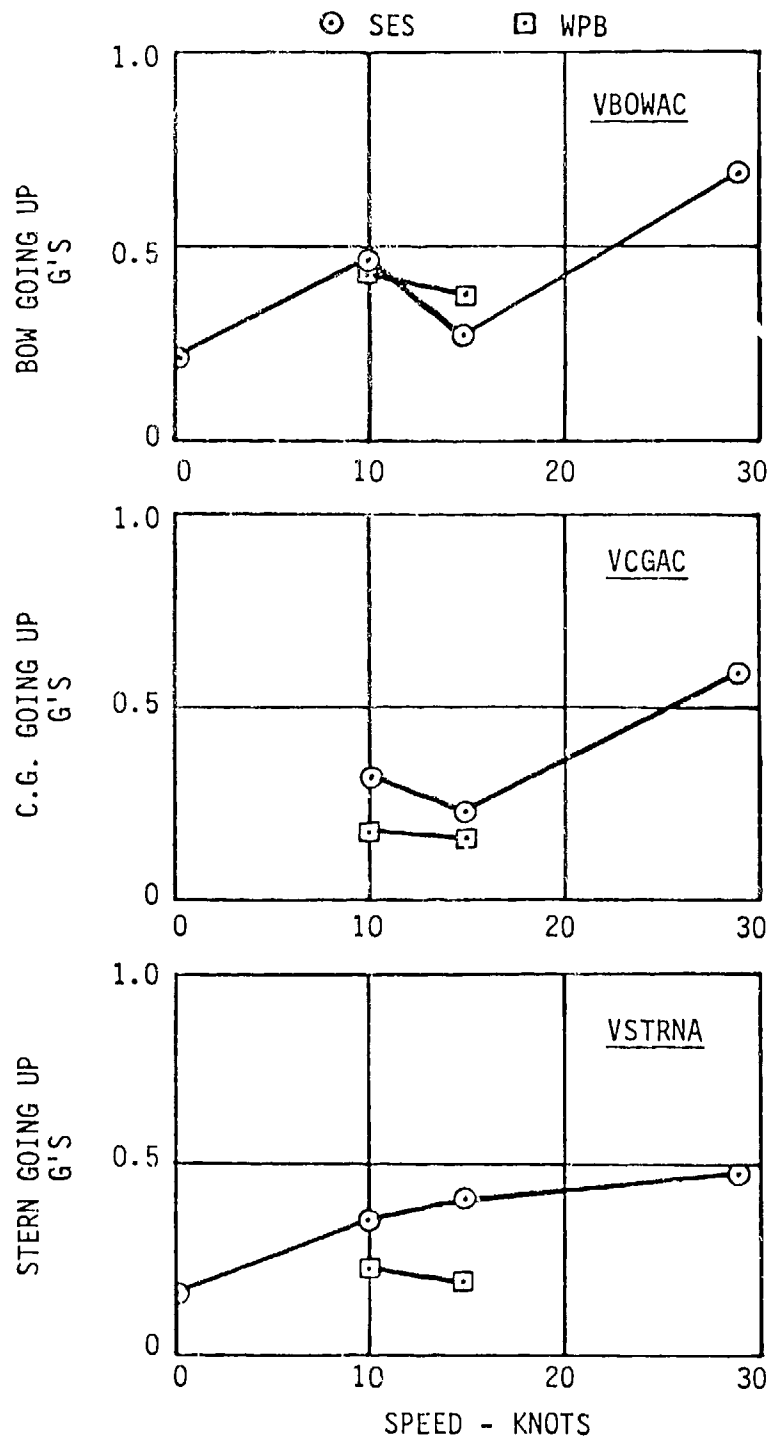

HEAD SEA  
SEA STATE 2  
29 FEB 1980

(b) Vertical Acceleration in Sea State 2

FIGURE 7. COMPARISON OF SEAWORTHINESS RESULTS FOR VARIOUS SEA STATES AND HEADINGS (CONTINUED)

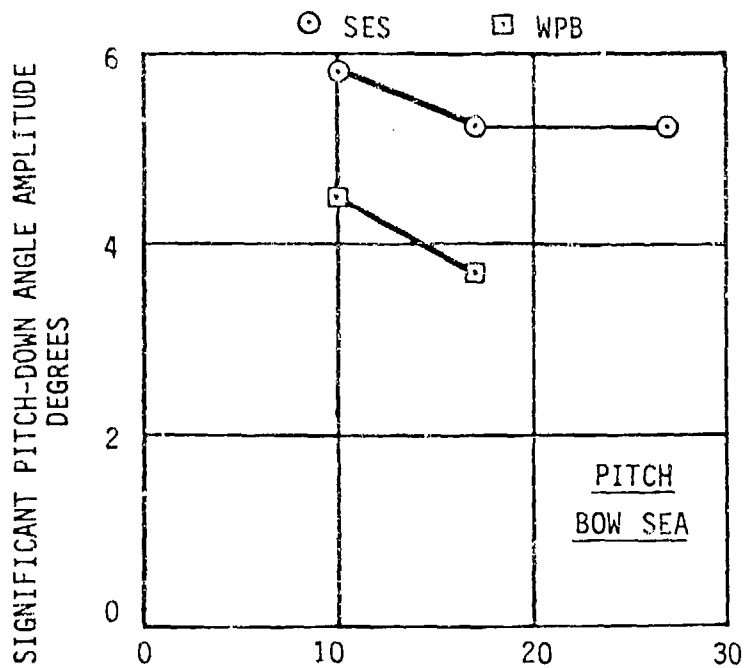

SEA STATE 4  
13 MAR 1980

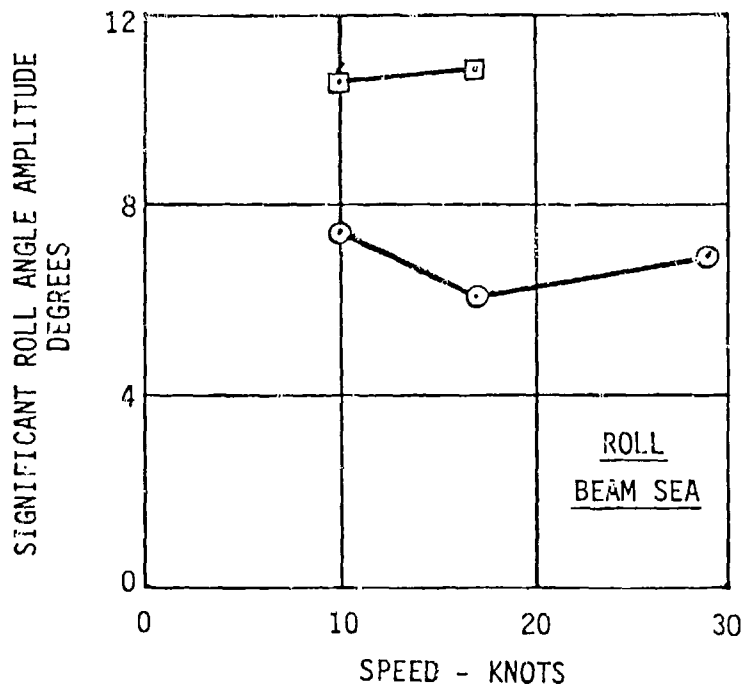

(c) Pitch and Roll in Sea State 4 (Avg. 1/3 Highest)

FIGURE 7. COMPARISON OF SEAWORTHINESS RESULTS FOR VARIOUS SEA STATES AND HEADINGS (CONTINUED)

SIGNIFICANT ACCELERATION AMPLITUDE

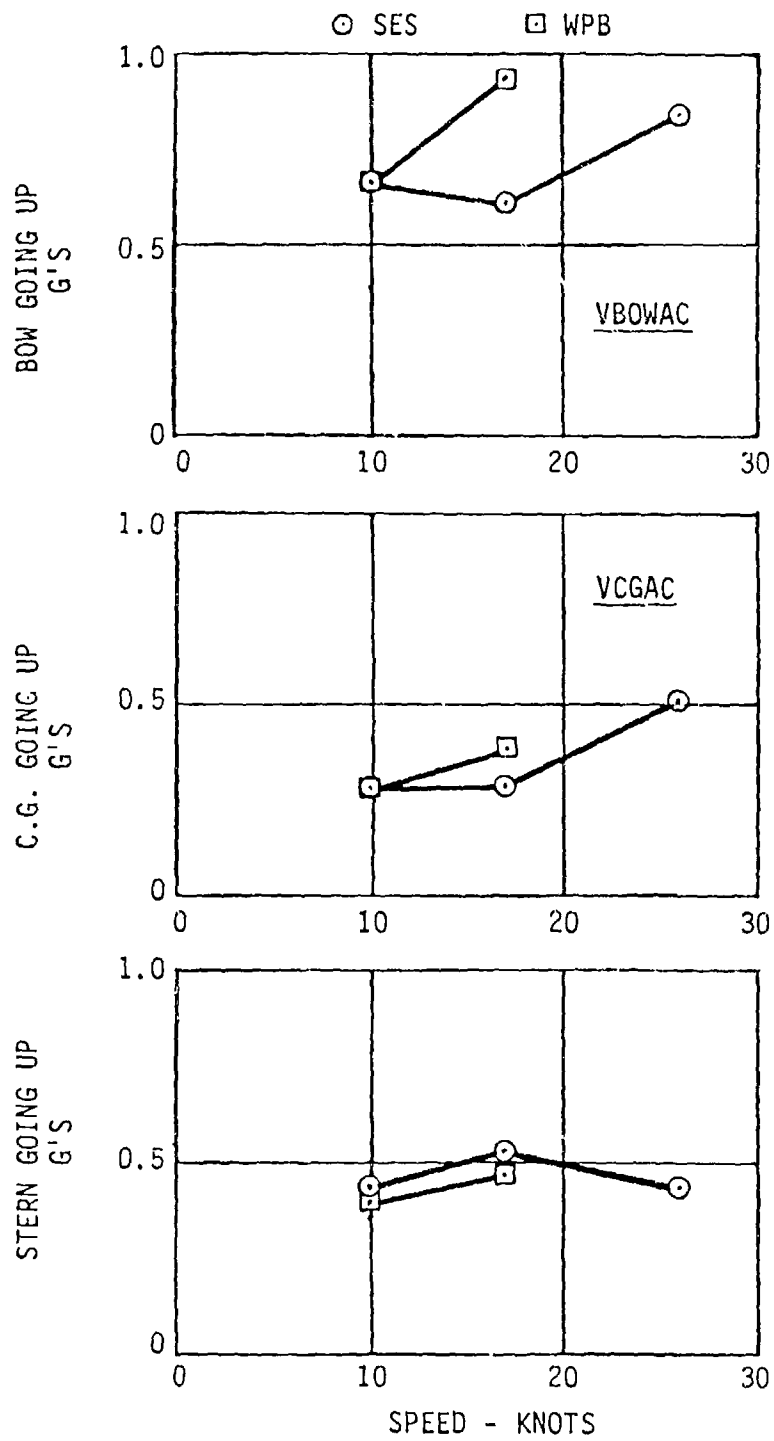

HEAD SEA  
SEA STATE 4  
13 MAR 1980

(d) Vertical Acceleration in Sea State 4  
(Avg. 1/3 Highest)

FIGURE 7. COMPARISON OF SEAWORTHINESS RESULTS FOR VARIOUS  
SEA STATES AND HEADINGS (CONTINUED)

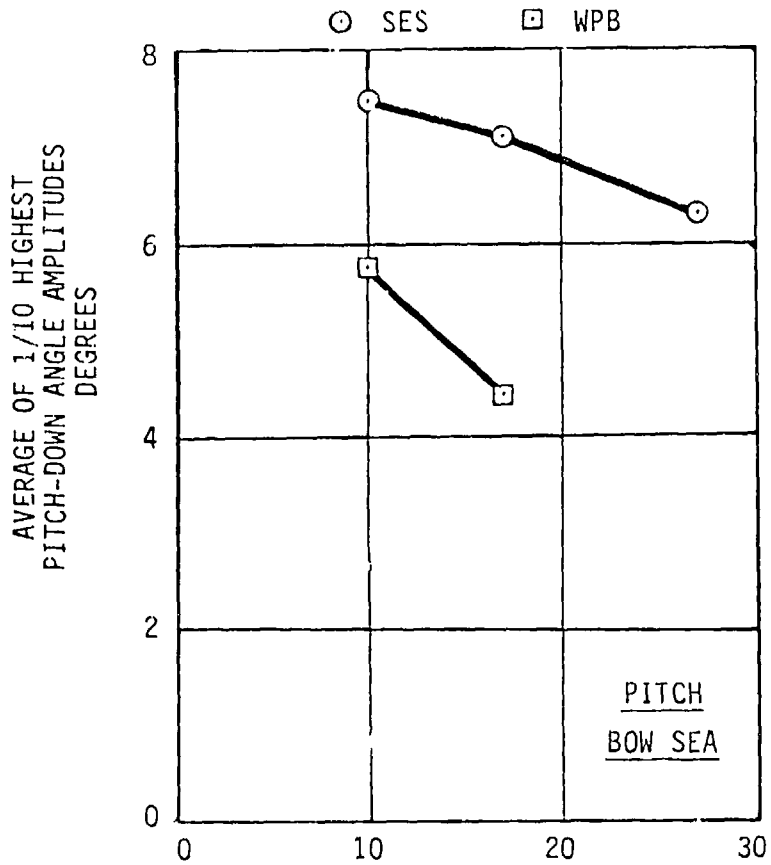

SEA STATE 4

13 MAR 1980

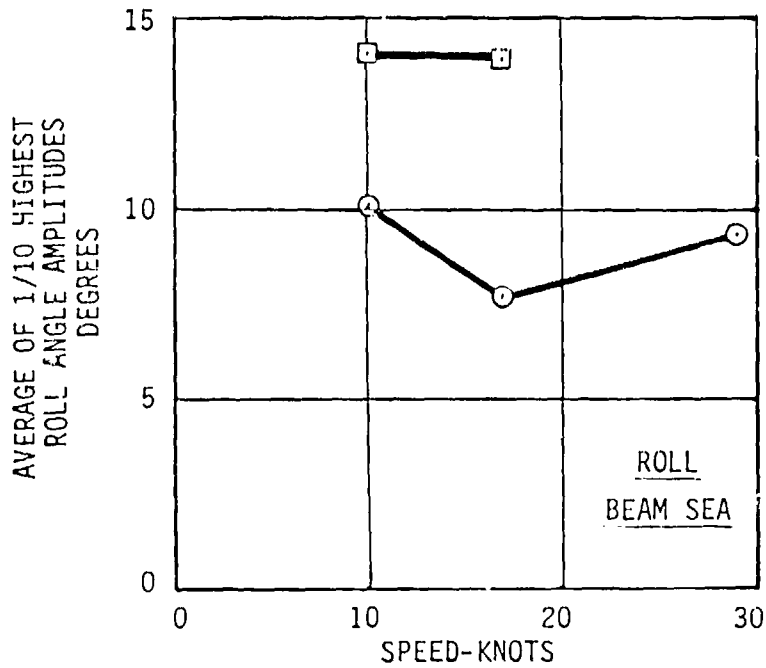

(e) Pitch and Roll in Sea State 4 (Avg. 1/10 Highest)

FIGURE 7. COMPARISON OF SEAWORTHINESS RESULTS FOR VARIOUS SEA STATES AND HEADINGS (CONTINUED)

AVERAGE OF 1/10 HIGHEST ACCELERATION AMPLITUDES

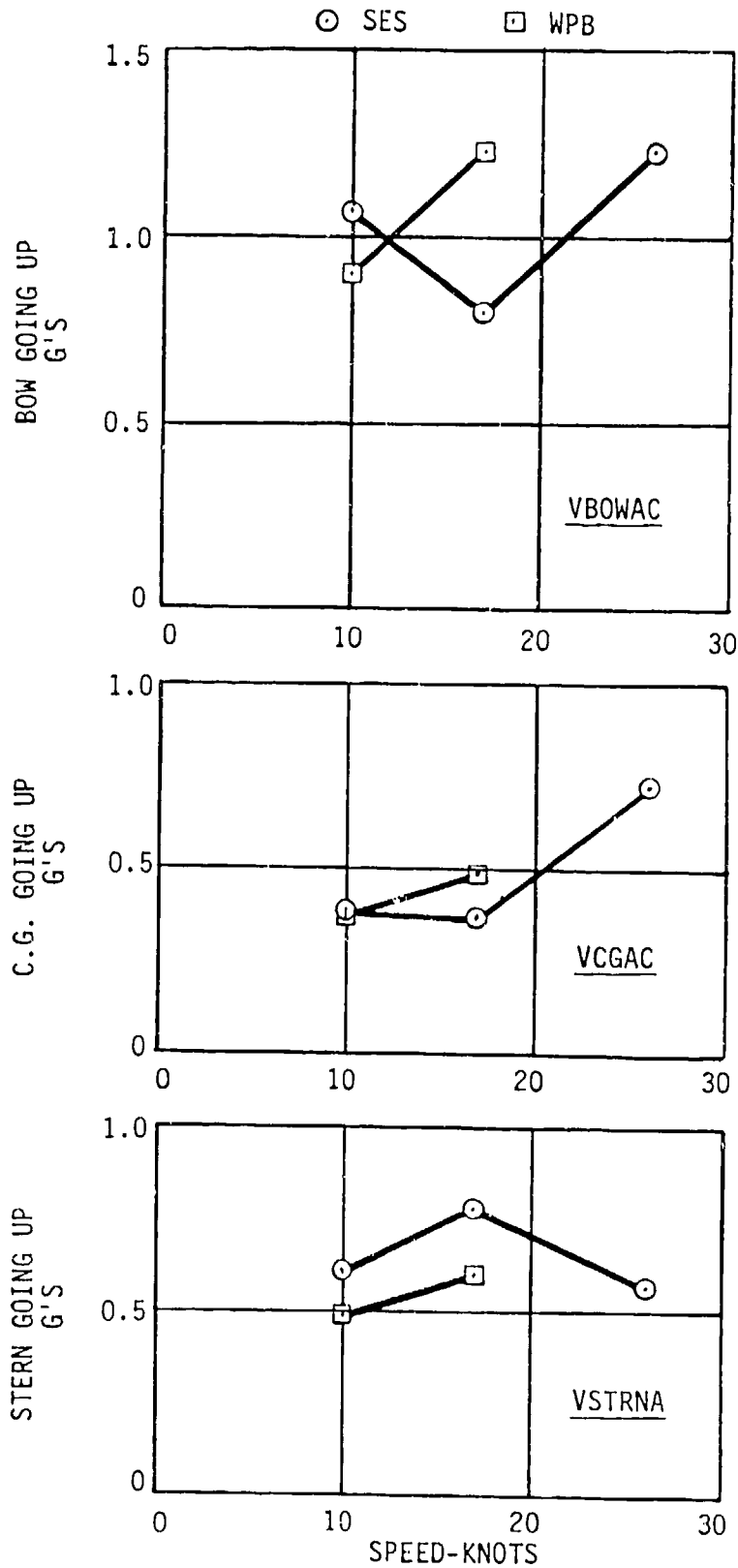

HEAD SEA  
SEA STATE 4  
13 MAR 1980

(f) Vertical Acceleration in Sea State 4  
(Avg. 1/10 Highest)

FIGURE 7. COMPARISON OF SEAWORTHINESS RESULTS FOR VARIOUS  
SEA STATES AND HEADINGS (CONTINUED)

## TOWING

Towing tests were conducted with the SES to assess both its ability as a towing vessel and its behavior when being towed. The other vessel utilized for both parts of the test was the 82-foot WPB with a normal displacement of approximately 146,000 pounds. SES displacement during these tests was approximately 272,000 pounds. For the towing test the SES was equipped with a temporary towpost located 31 feet forward of the transom. When being towed, the SES was rigged with a two-legged bridle bent to the forward mooring bits. A single towline rode this bridle and passed through the bullnose in the bow. These arrangements are shown in figure 8. A 600-foot towline was used in both arrangements and a load cell to measure towline tension was located at the SES end (shown in figure 8).

The SES towed the WPB at speeds up to 11 knots at various settings of cushion fan speed. Towing speed was limited by WPB operational considerations, as considerable SES thrust capability remained. The SES handled this tow without any unusual characteristics. The WPB was towed in alignment with a light wind, wind on the beam, and through a 180-degree left turn at the maximum speed condition. Shaft rpm, towline tension, and fuel consumption as functions of speed of tow are presented in figure 9. Figure 9 shows that optimum towing speed and fuel consumption (within the conditions tested, given the towline strength limits) occur at moderate fan rpm (cushion pressure). It was observed that at the higher fan speed (1460 rpm), the SES directional stability was starting to become "tender" and mist escaping from the cushion interfered with visibility of the towed vessel. Sea conditions were calm.

The WPB towed the SES at speeds up to 6 knots with the SES off cushion and at two cushion fan rpms. WPB shaft rpm and towline tension as functions of speed of tow are presented in figure 10. The SES tracked and turned behind the WPB without any unusual characteristics in calm seas with 5 to 10 knot winds. Beam winds did not cause the SES to drift off course when either on or off cushion. A steady vibration was present on the SES at the higher fan speed (1445 rpm). Figure 10 indicates there is little advantage to using the SES fans when under tow. The 1 to 1.3 knot speed increase the fans provide at a given shaft rpm for the WPB can be obtained without the fans by increasing shaft speed approximately 50 rpm.

In conjunction with the towing tests, the SES was brought alongside the stopped WPB in moderate seas; the vessels were secured together while personnel moved back and forth; and the SES cleared the WPB. This exercise was conducted without incident. The WPB was observed to have a considerably greater roll motion than the SES when D.I.W. in the same sea.

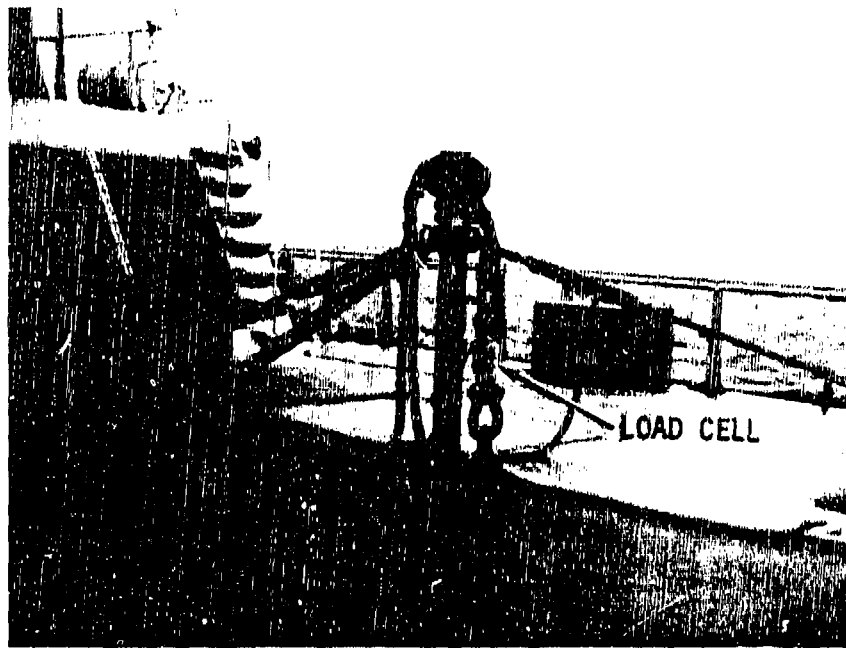

(a) SES TOWPOST DETAILS WITH LOAD CELL  
RIGGED FOR TOWING



(b) SES TOWING WPB 11 KNOTS

FIGURE 8. VARIOUS VIEWS OF TOWING TESTS

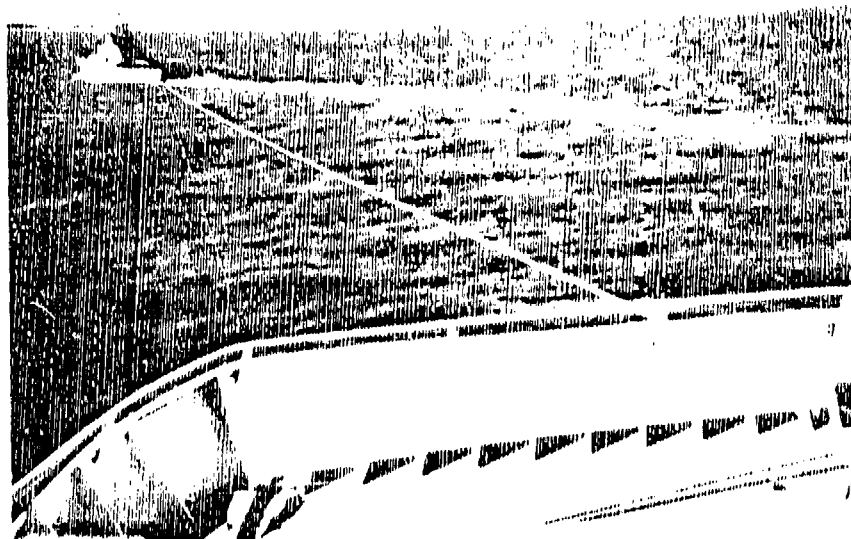

(c) WPB TOWING SES IN LEFT TURN

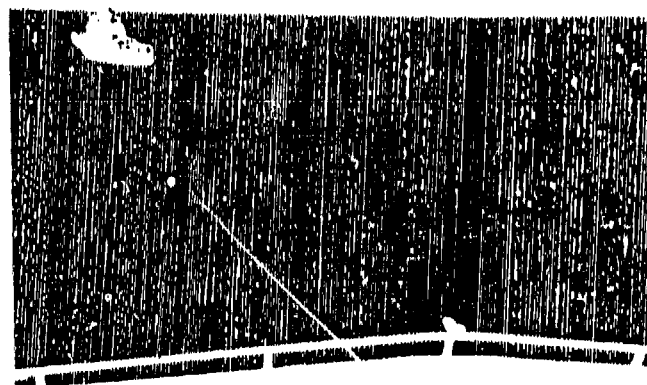

(d) WPB TOWING SES SHOWING  
TOWING BRIDLE ON SES

FIGURE B. VARIOUS VIEWS OF TOWING TESTS (Continued)

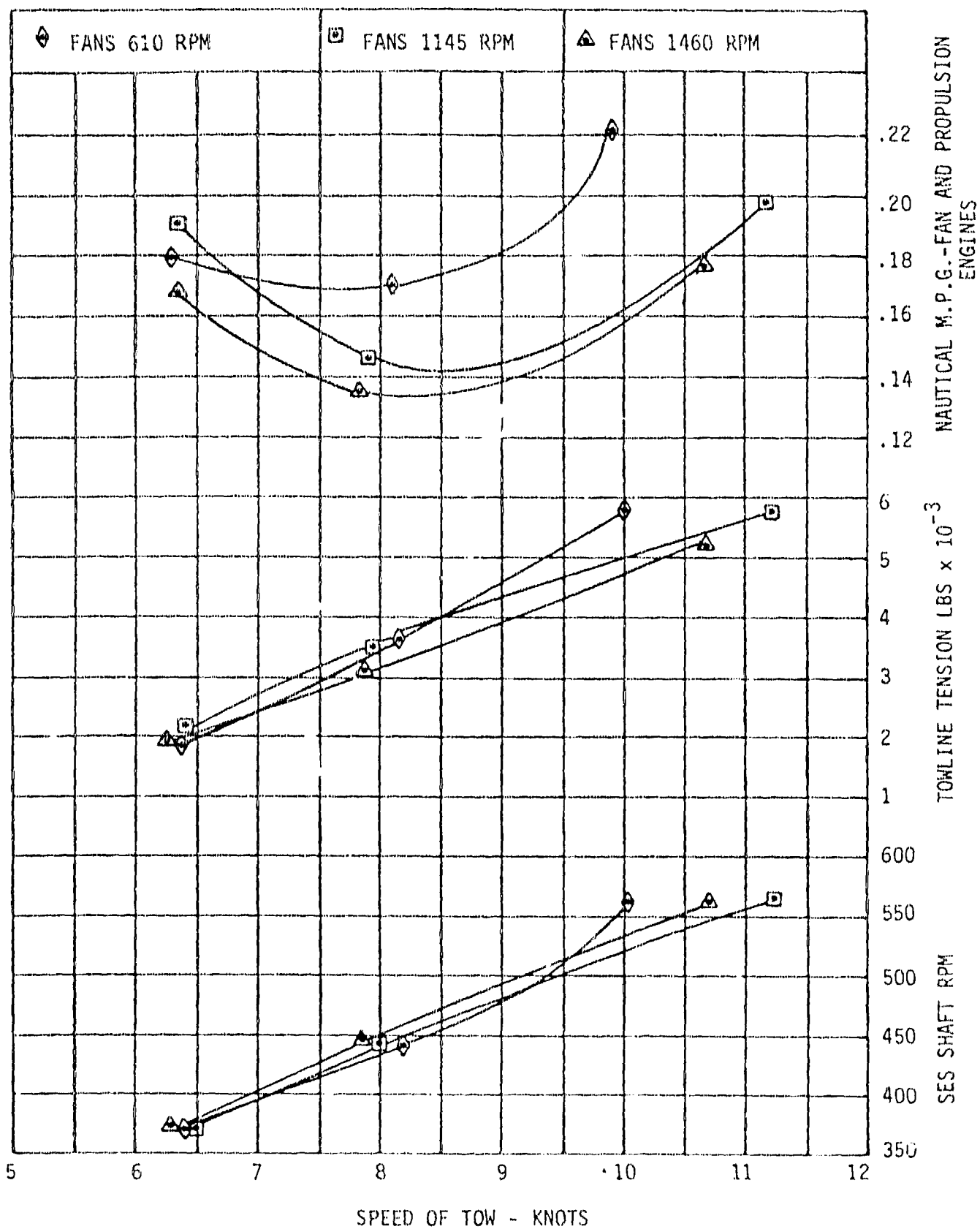

FIGURE 9. TOWING TEST RESULTS - SES TOWING WPB

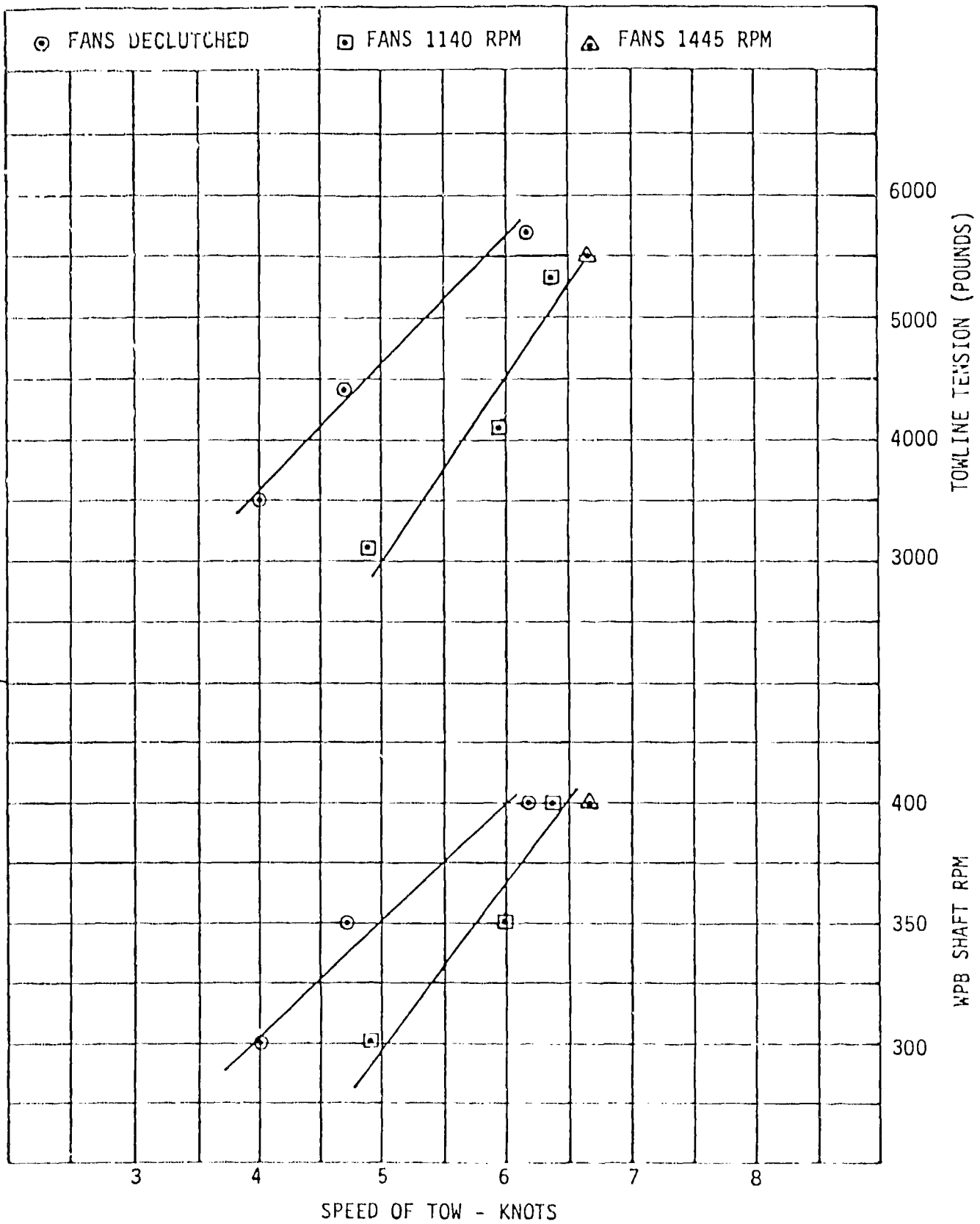

FIGURE 10. TOWING TEST RESULTS - WPB TOWING SES

59/60 Blank

## BOLLARD PULL

The bollard pull test was performed at the Coast Guard Support Center, Portsmouth, Virginia. The SES was secured by a line running from the towpost to a bollard 150 feet aft of the craft near the end of a finger pier. The pull force was normal to the axis of the pier and was measured by a load cell inserted in the line at the towpost end. The test arrangement is shown in figure 11.

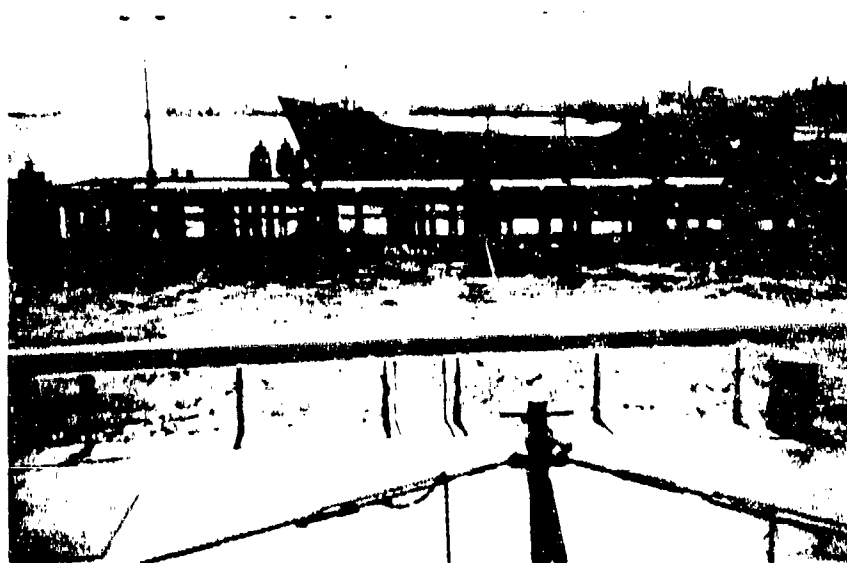

FIGURE 11. TEST ARRANGEMENT FOR BOLLARD PULL

The first condition tested was with the SES off cushion. The propulsors were placed in ahead gear and the rpm increased in equal increments and bollard pull measured at each rpm as steady conditions were reached. Test results are presented in figure 12 with bollard pull as a function of shaft rpm and shp. As indicated in figure 12, testing was terminated when the line parted at 18,800 pounds pull at 440 rpm. The test was terminated due to the potential energy buildup in the line coupled with the closeness of the SES to other piers and vessels, creating a safety hazard. Therefore, the test conditions planned with one engine operation and on cushion were not performed. The bollard pull results are projected to higher values of rpm and shp in figure 12. Bollard pull is usually limited by propulsion thrust breakdown due to cavitation and/or surface ventilation. The point of this limitation was not reached during this test and is not considered in the resultant projection.

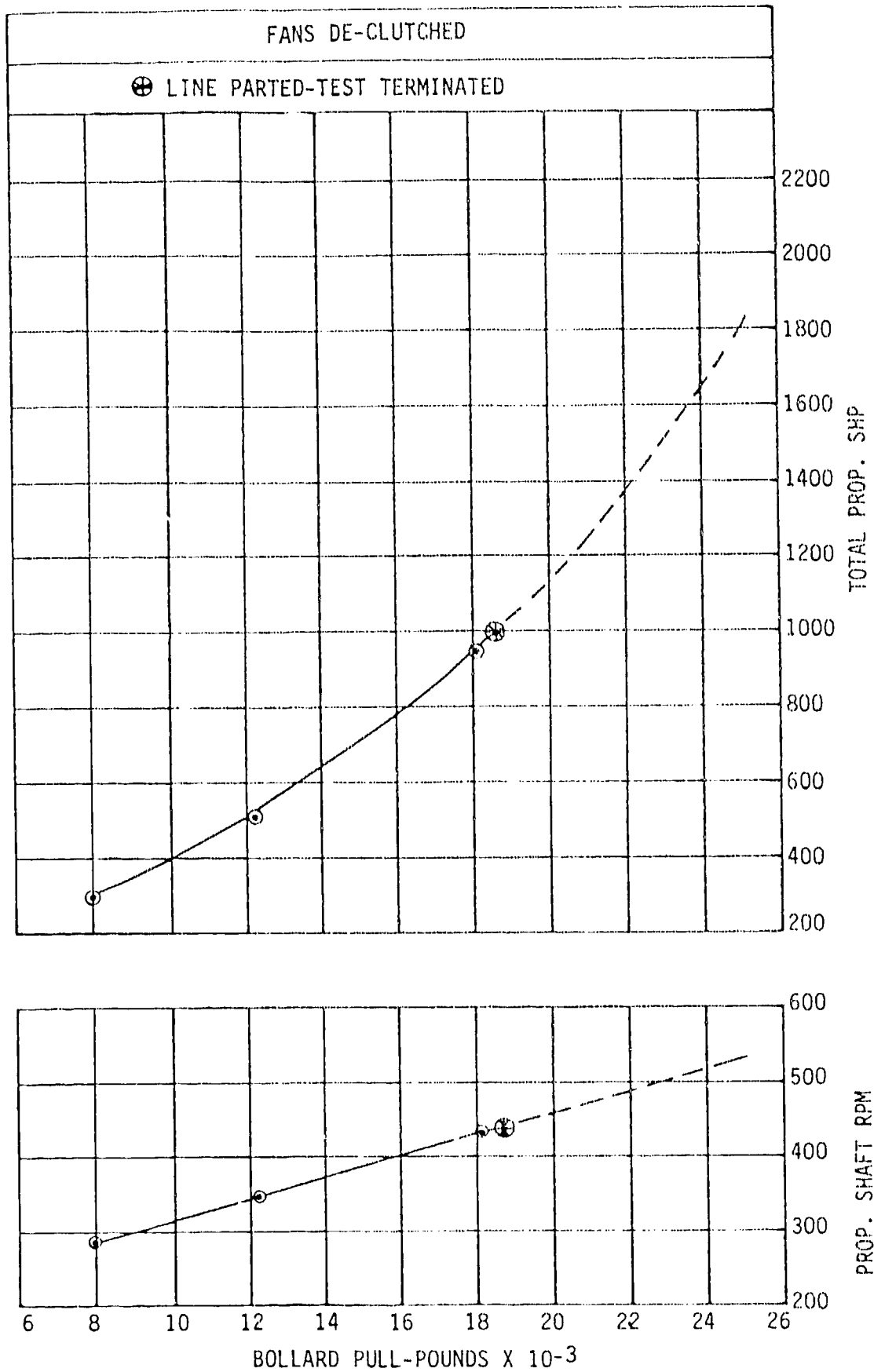

FIGURE 12. RESULTS OF OFF CUSHION BOLLARD PULL TEST

## SPEED PERFORMANCE

Speed trials were performed with the SES at the normal operating displacement of 272,000 pounds and at a simulated full load displacement of 314,000 pounds (42,000 pound payload). Torque was measured on one propeller shaft along with fuel consumption on that propulsion engine and one fan engine. RPM was measured on both propeller shafts and both lift fan shafts. These measurements yielded sufficient information to compute the total shp and fuel consumption of the propulsion and fan engines for each test point. Each test point was determined by averaging the results recorded during at least one run in each direction over a 3000-foot-long measured course along the Chesapeake Bay Bridge Tunnel where water depth varied from 26 to 34 feet. This relatively shallow water depth should have slightly improved speed performance. The speed results, partially reported previously in the interim report of reference 5, are presented in figures 13 and 14. The displacements listed in figure 13 were adjusted from those listed in reference 5 following the scale weighing of the SES. Figure 13 shows a total applied horsepower of 3600 shp at a maximum speed of 33 knots and a distinct economical cruising speed range of 22 to 29 knots. The dotted-line portions of the performance curves of Figure 13 between 14 and 19 knots represent the speed transition range from displacement to planing modes of operation. Performance characteristics tend to be unsteady in this range and are impossible to measure accurately; therefore, the dotted lines represent an approximation of the magnitude of the subject parameters in this narrow transitional speed range. Figure 14 shows an example of the contribution of the fans to the SES speed performance and efficiency. Figure 14 is the result obtained when leaving the main engine throttles at a fixed setting and incrementally increasing fan rpm and therefore cushion pressure. The main engine shafts are seen to increase in speed as the fan-generated cushion reduces vessel drag, and therefore shaft loading, allowing increases in vessel speed. The speed efficiency is seen to increase with fan rpm, but at a declining rate, as maximum fan rpm is approached.

BOAT: BELL-HALTER 110 FT. SES

DATE: 19-20 FEB 1980

DISPLACEMENT:	272,000 POUNDS	314,000
DRAFT (STATIC, MEAN)	7.70 FEET	8.19
STATIC TRIM (REF. B.L.)	-0.6 (X BOW) DEGREES	-2.6 (X BOW)
PROPELLER DIAMETER	41.9 INCHES	41.9
PROPELLER PITCH	50.5 INCHES	50.5
MEAN WATER DEPTH	27 FEET	27

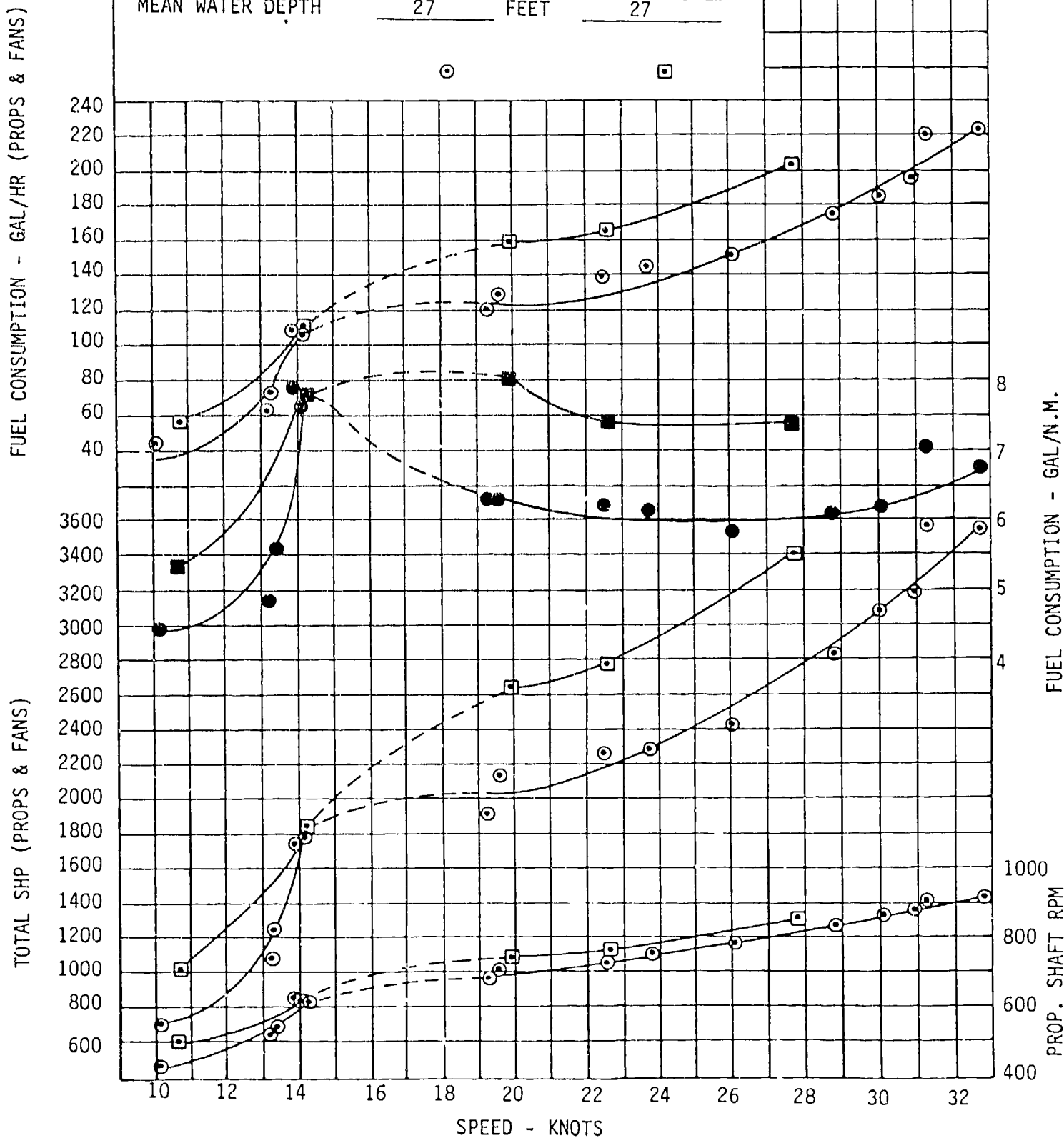

FIGURE 13. RPM, SHAFT HORSEPOWER AND FUEL REQUIREMENTS AS A FUNCTION OF SPEED

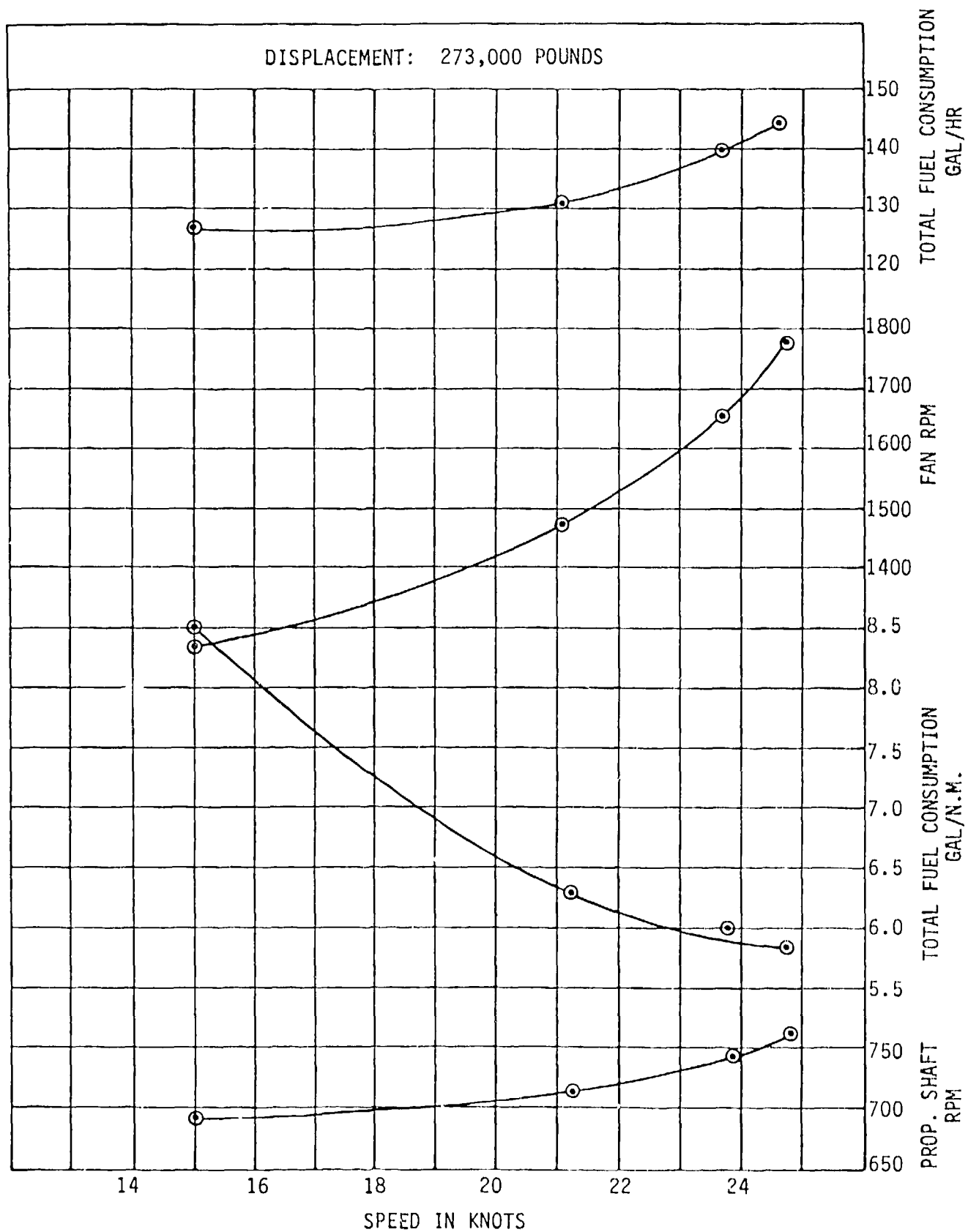

FIGURE 14. PERFORMANCE WITH FIXED PROPULSION THROTTLE AND VARYING FAN SPEEDS

## TURNING AND MANEUVERABILITY

The SES was operated through a series of left and right turns during which the throttles (matched rpm's on propeller shafts and on fan shafts) and rudder angle were held constant. Craft speed was held steady at the start of each turn in groups of low, medium, and high speed runs. Turning diameter was measured with a tracking system as the lateral displacement of the craft from the course from which the turn was started to the parallel course through the point where the craft had changed heading 180 degrees. Heading was monitored with a MK 27 gyrocompass and time to turn 180 degrees was provided by the tracking system printout. Wind and sea conditions were approximately calm during these tests and tidal current, as judged by flow about a navigation buoy in the area, was insignificant. Test results are not corrected for set and drift, the effects of which were judged to be minimal. The initial operating conditions, turning diameter, and turning time results are presented in figures 15 and 16 for on-cushion and off-cushion operating modes. The SES is seen to turn slightly better to the left for a given rudder setting at the low speed and slightly better to the right at medium and high speeds. The off-cushion tests (figure 15) were restricted to 13 knots which was judged to be the maximum safe speed for the structural integrity of the stern seal.

Maneuverability of the SES was judged qualitatively when winding or rotating about a vertical axis amidship utilizing engines only and during various and numerous docking procedures. Winding on engines only is easily performed either on or off cushion with a greater degree of control in the off-cushion mode. At and near piers and other vessels (at close quarters) the SES handles in a controlled and predictable manner. When subjected to high cross winds, or gusty winds in general, low speed maneuverability and control is superior in the off-cushion mode. At higher than docking speeds, control on or off cushion is simply a matter of steering through the maneuver required.

CRAFT:	110 FT. BELL-HALTER SES	
DISPLACEMENT:	278,000 POUNDS	
MEAN WATER DEPTH:	60 FT.	
SHAFT RPM:	430	
FAN RPM:	1315	
SPEED AT START:	10 KNOTS	

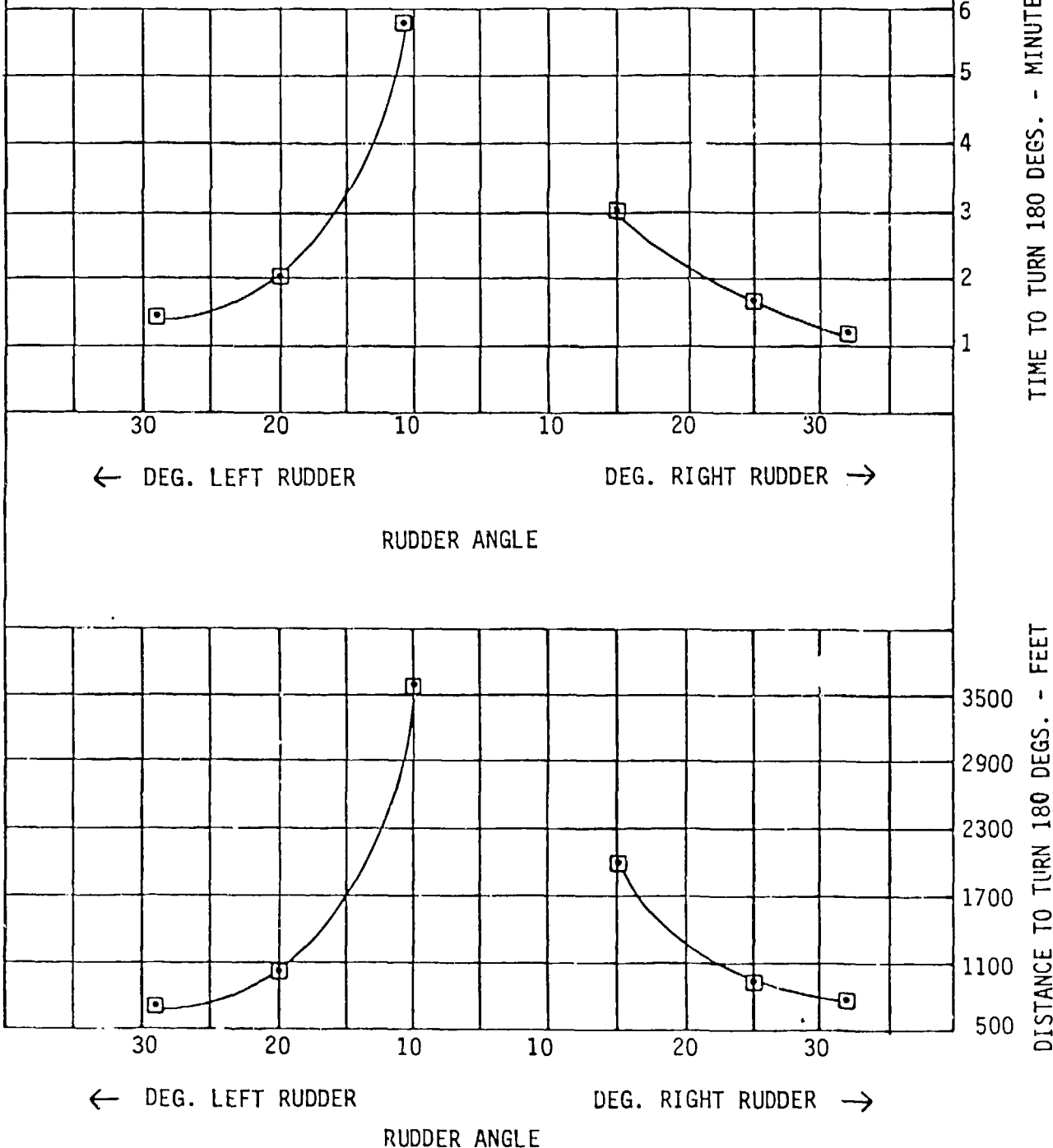

FIGURE 15. TURNING DIAMETER FOR VARIOUS RUDDER ANGLES AND SPEEDS (ON CUSHION)

CRAFT: 110 FT. BELL-HALTER SES  
 DISPLACEMENT: 278,000 POUNDS  
 MEAN WATER DEPTH: 60 FT.  
 SHAFT RPM: 725  
 FAN RPM: 1525  
 SPEED AT START: 20 KTS

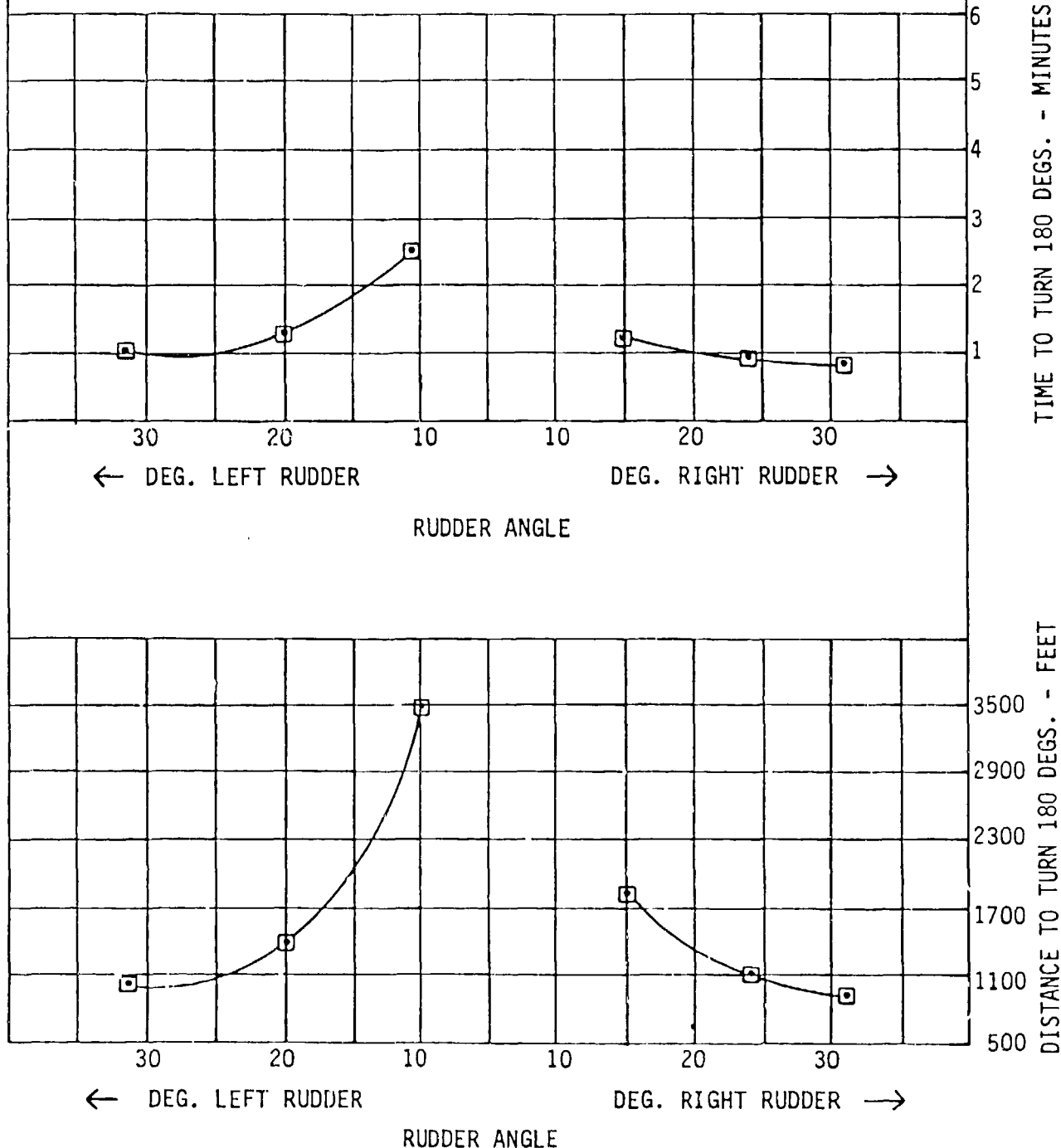
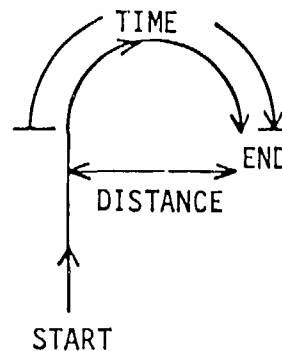

FIGURE 15. TURNING DIAMETER FOR VARIOUS RUDDER ANGLES AND SPEEDS (ON CUSHION) (Continued)

CRAFT: 110 FT. BELL-HALTER SES  
 DISPLACEMENT: 278,000 POUNDS  
 MEAN WATER DEPTH: 60 FT  
 SHAFT RPM: 905  
 FAN RPM: 1750  
 SPEED AT START: 31 KTS

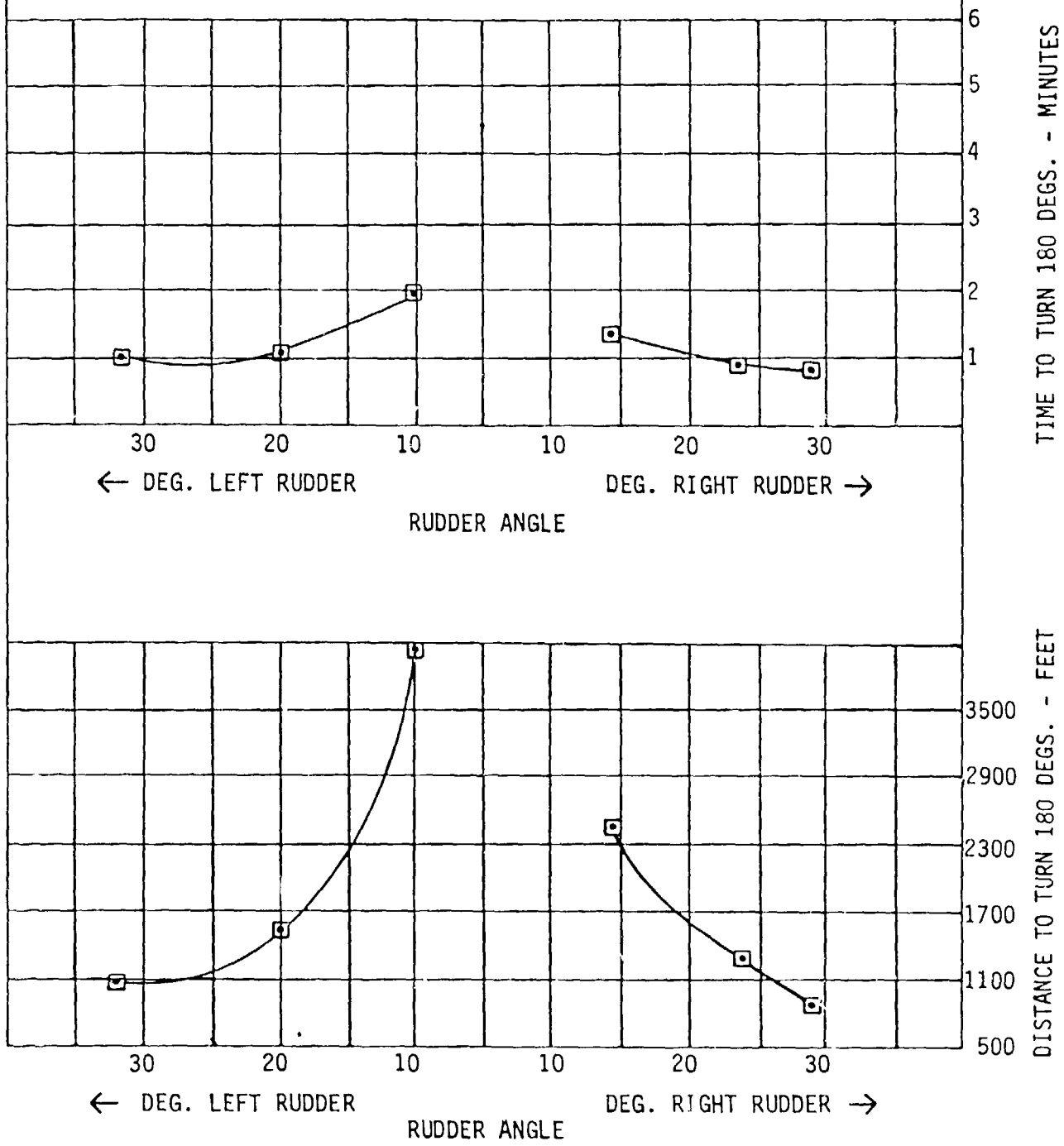
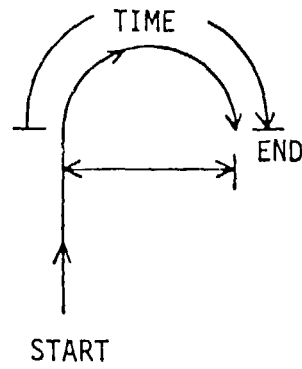

FIGURE 15. TURNING DIAMETER FOR VARIOUS RUDDER ANGLES AND SPEEDS (ON CUSHION) (Continued)

CRAFT: 110 FT. BELL-HALTER SES  
 DISPLACEMENT: 278,000 POUNDS  
 MEAN WATER DEPTH: 60 FT.  
 SHAFT RPM: 550  
 FAN RPM: DECLUTCHED (OFF CUSHION)  
 SPEED AT START: 13 KTS

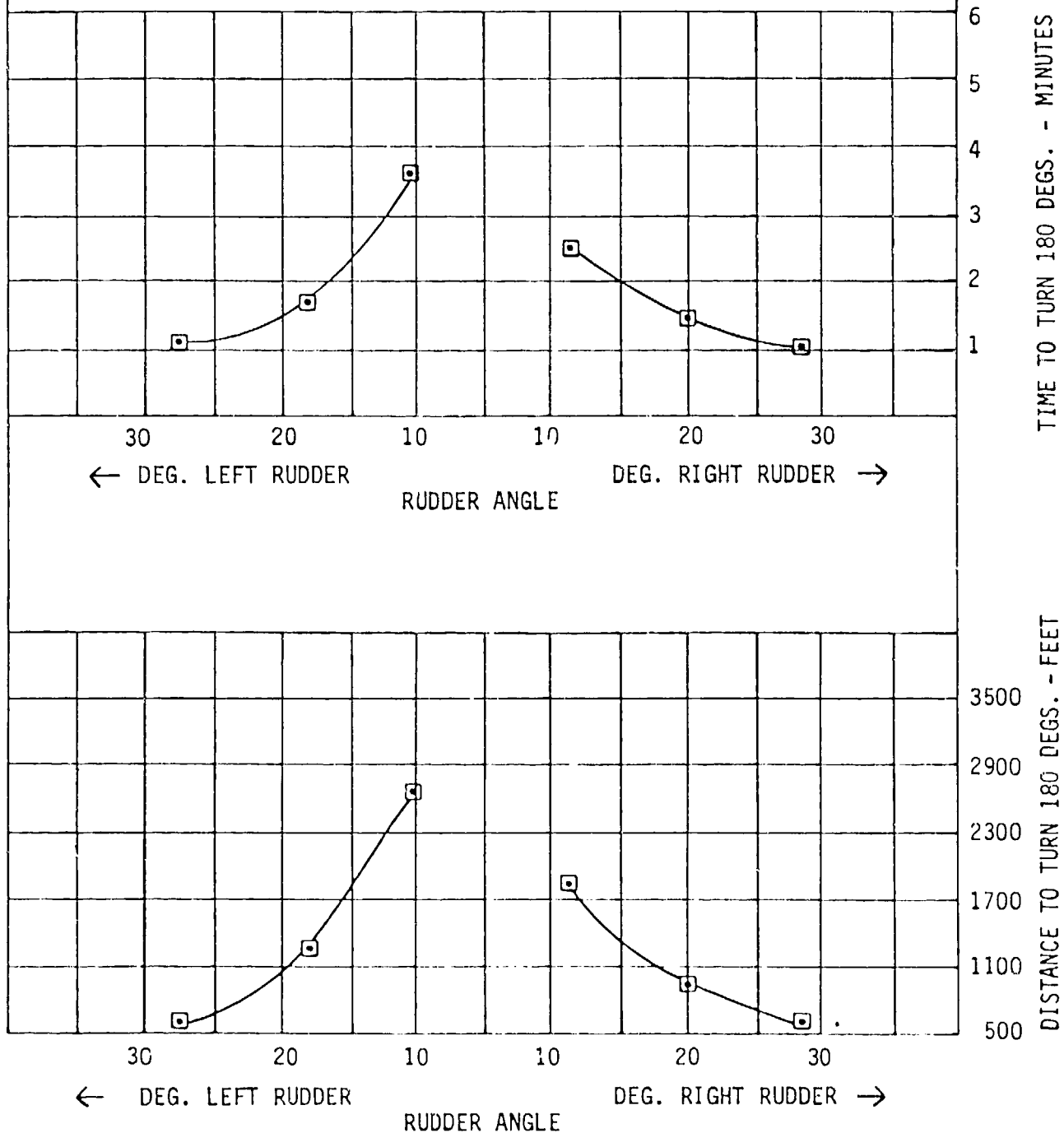
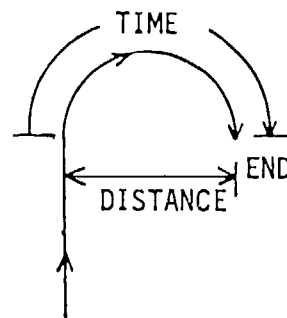

FIGURE 16. TURNING DIAMETER FOR VARIOUS RUDDER ANGLES (OFF CUSHION)

## DIRECTIONAL STABILITY AND IMPAIRED ENGINE TESTS

A quantitative measurement was made of the directional and control stability characteristics of the SES when operated in the normal (on-cushion) mode, off-cushion mode, and with simulated engine failures. These tests were conducted in calm seas. Test procedure for each operating mode was to demonstrate ability to keep a straight course, then perform a zig-zag maneuver followed by a return to the straight course. Figures 17 to 23 present time histories of the SES response to these test procedures. Rudder angle is the operator input required to bring about the craft response, measured at the rudder. Boat heading is degrees of yaw to the left or right of the original course that the craft makes in response to the rudder input. Rudder angle and heading are plotted versus time from the start to the end of the maneuver. Craft speed at the start, propeller and fan rpm, and operating mode are stipulated on each figure. These results show that the SES is capable of straight course keeping and zig-zag maneuvering when on or off cushion and with one or two fans impaired and with one main engine impaired.

Dieudonne spiral maneuvers were performed with the SES for the various operating modes and simulated engine impairments. This maneuver consists of turning from a straight course, while maintaining fixed throttles, in small increments of rudder angle to full rudder in one direction, then in increments to full rudder in the opposite direction, and finally back to the starting position. Each incremental rudder setting is held until a steady rate of turn is achieved and recorded. When the resulting rates of turn are plotted versus rudder angle, ideally stable steering characteristics are exemplified by a straight line that passes through the 0,0 origin. Deviations from the ideal are revealed by non-linearity and "hysteresis loops" in the rudder angle-turn rate relationship.

Spiral maneuver test results are presented in figures 24 to 30. Figures 24 and 25 are for normal, on-cushion operation at medium and high speed. Figure 24 (medium speed) shows good symmetrical rudder response with a slight breakdown at extreme left rudder probably due to some venting. Figure 25 shows good response to small rudder angles but increased breakdown at large rudder angles due to the higher speed. Figure 26 shows slightly better results at the same speed as figure 24 with one lift engine secured. The slight improvement may indicate cushion air pressure is a factor in rudder performance due to its contribution in the venting process. Figures 27 and 28 show results with simulated engine impairments.

As would be expected, steering performance declines rapidly when turning away from the side with the secured propulsion engine. Figures 29 and 30 give results for off-cushion operation. Figure 29, normal off-cushion operation, shows results similar to on-cushion operation. Figure 30, off-cushion with an impaired propulsion engine shows better results than on-cushion (figure 27) and similar to on-cushion with one impaired lift engine (figure 28). Previous comments concerning forced ventilation probably also apply in this case.

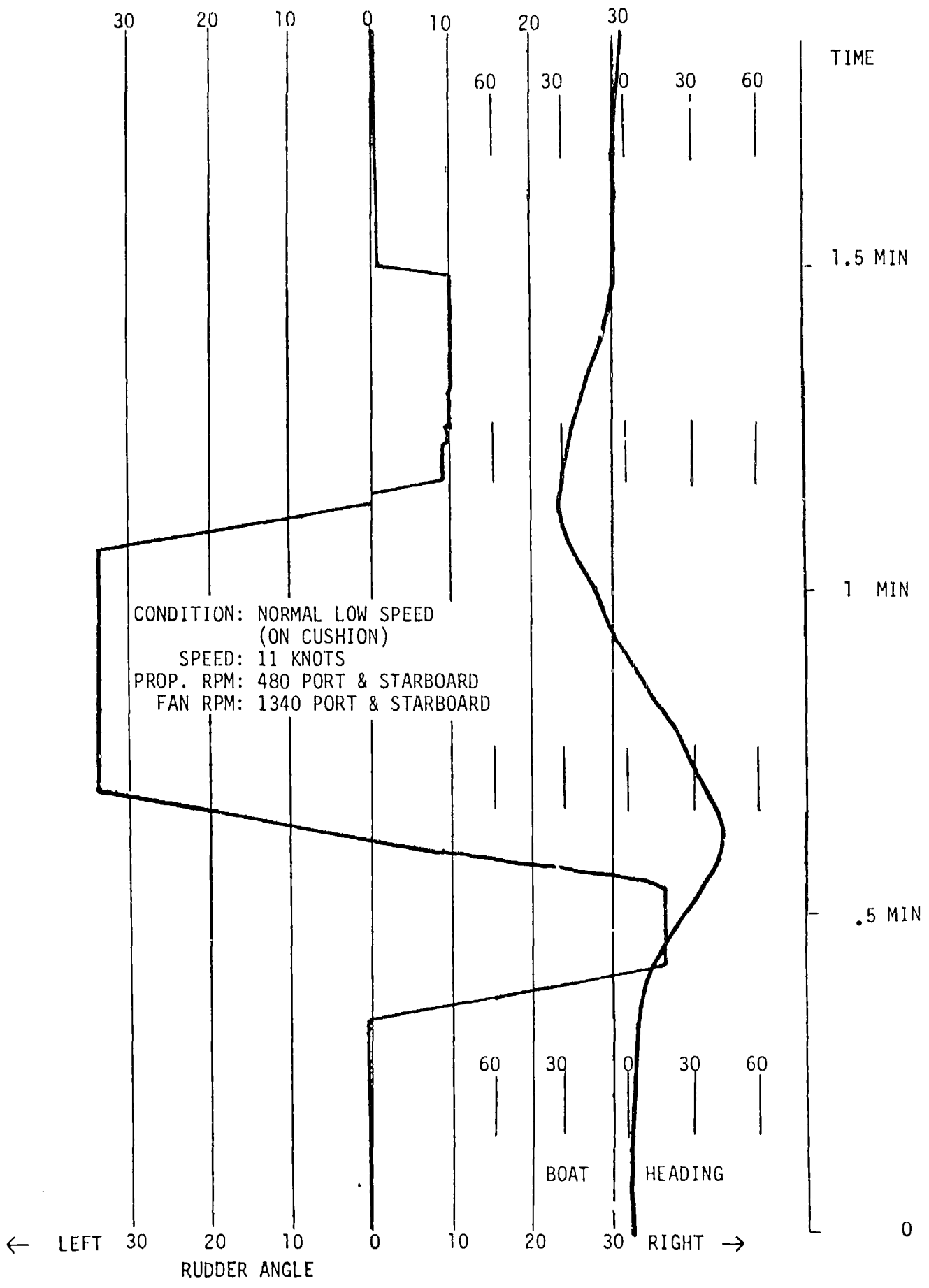

FIGURE 17. DIRECTIONAL STABILITY AT NORMAL LOW SPEED (ON CUSHION)

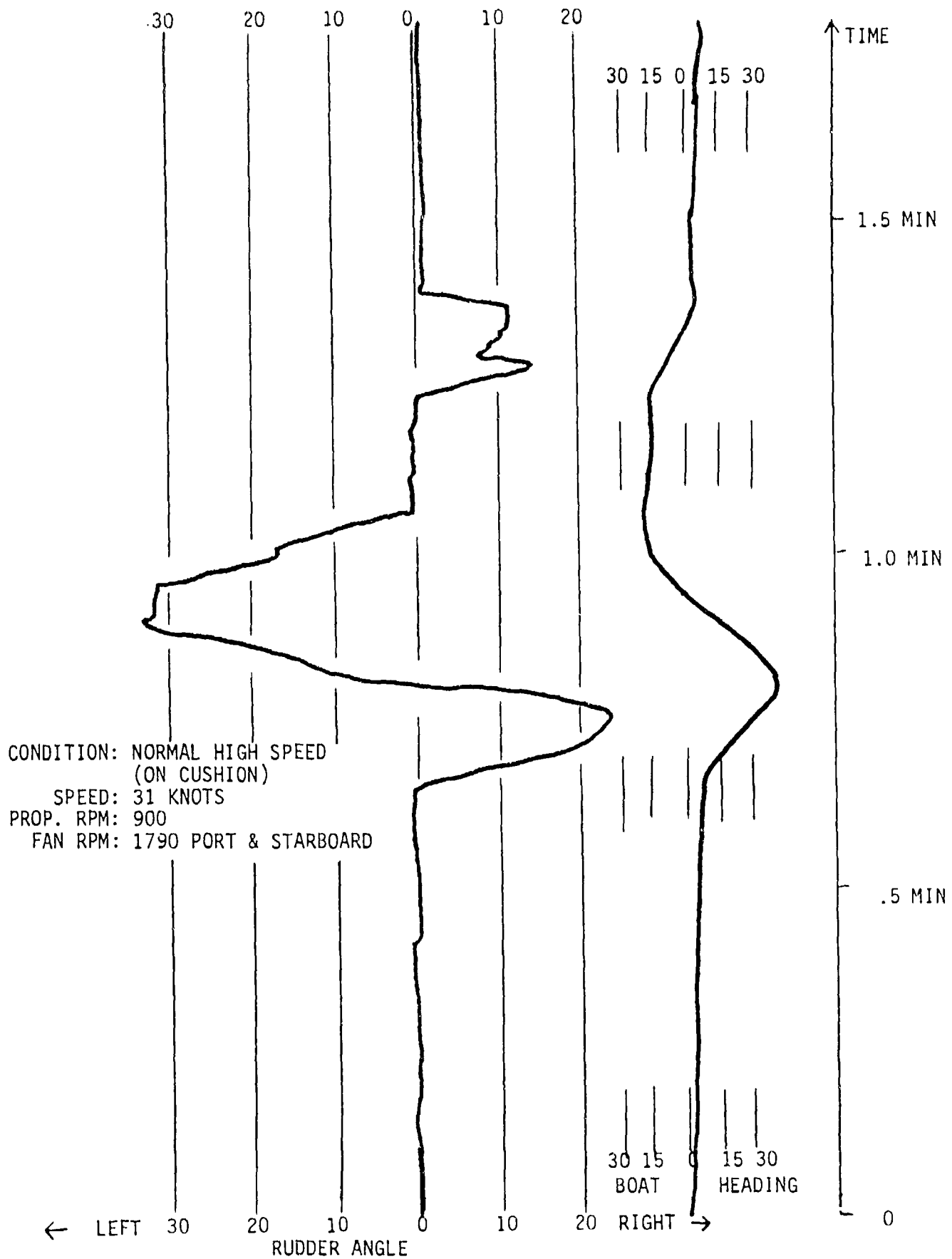

FIGURE 18. DIRECTIONAL STABILITY AT NORMAL HIGH SPEED (ON CUSHION)

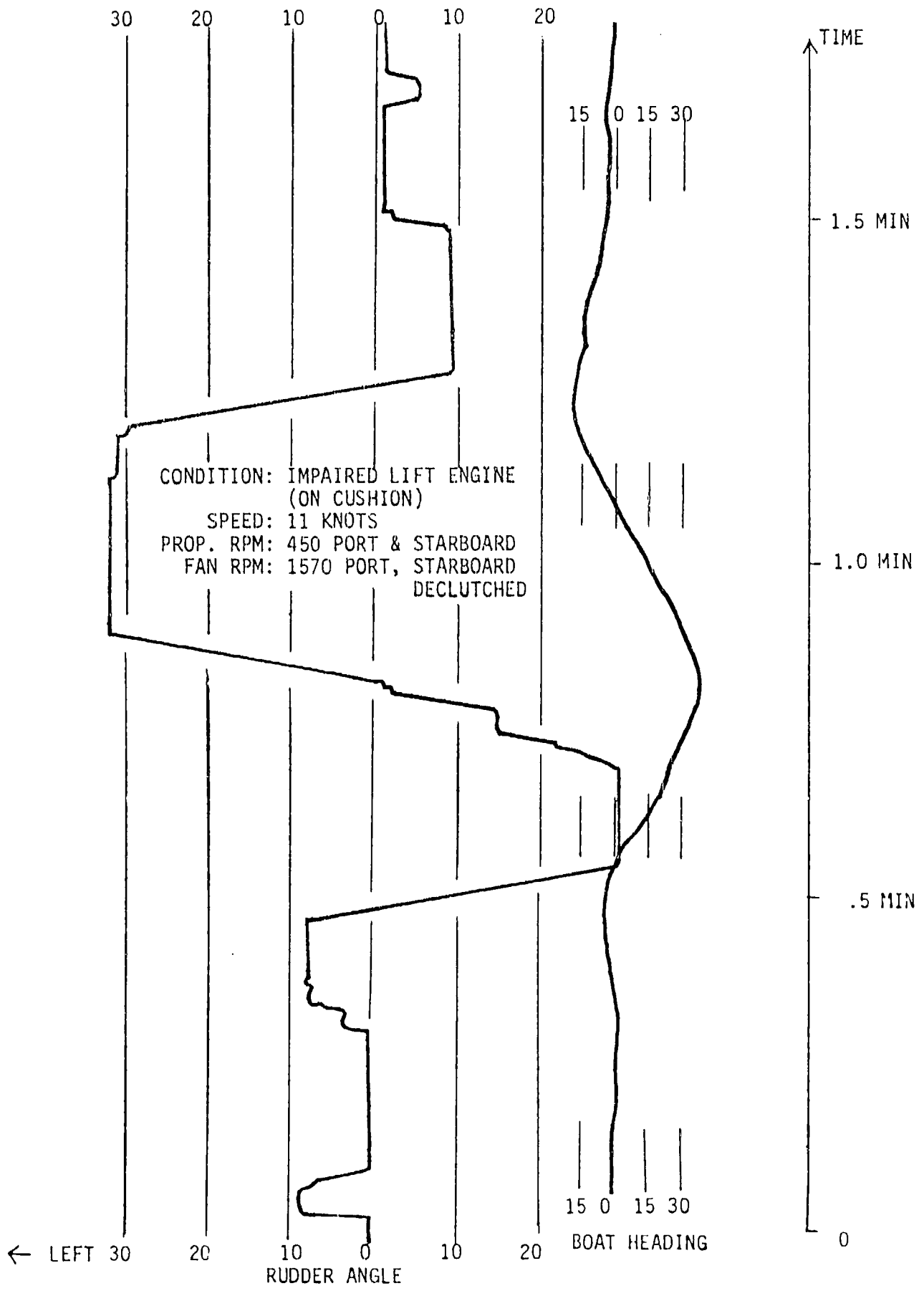

FIGURE 19. DIRECTIONAL STABILITY AT NORMAL LOW SPEED WITH IMPAIRED LIFT ENGINE (ON CUSHION)

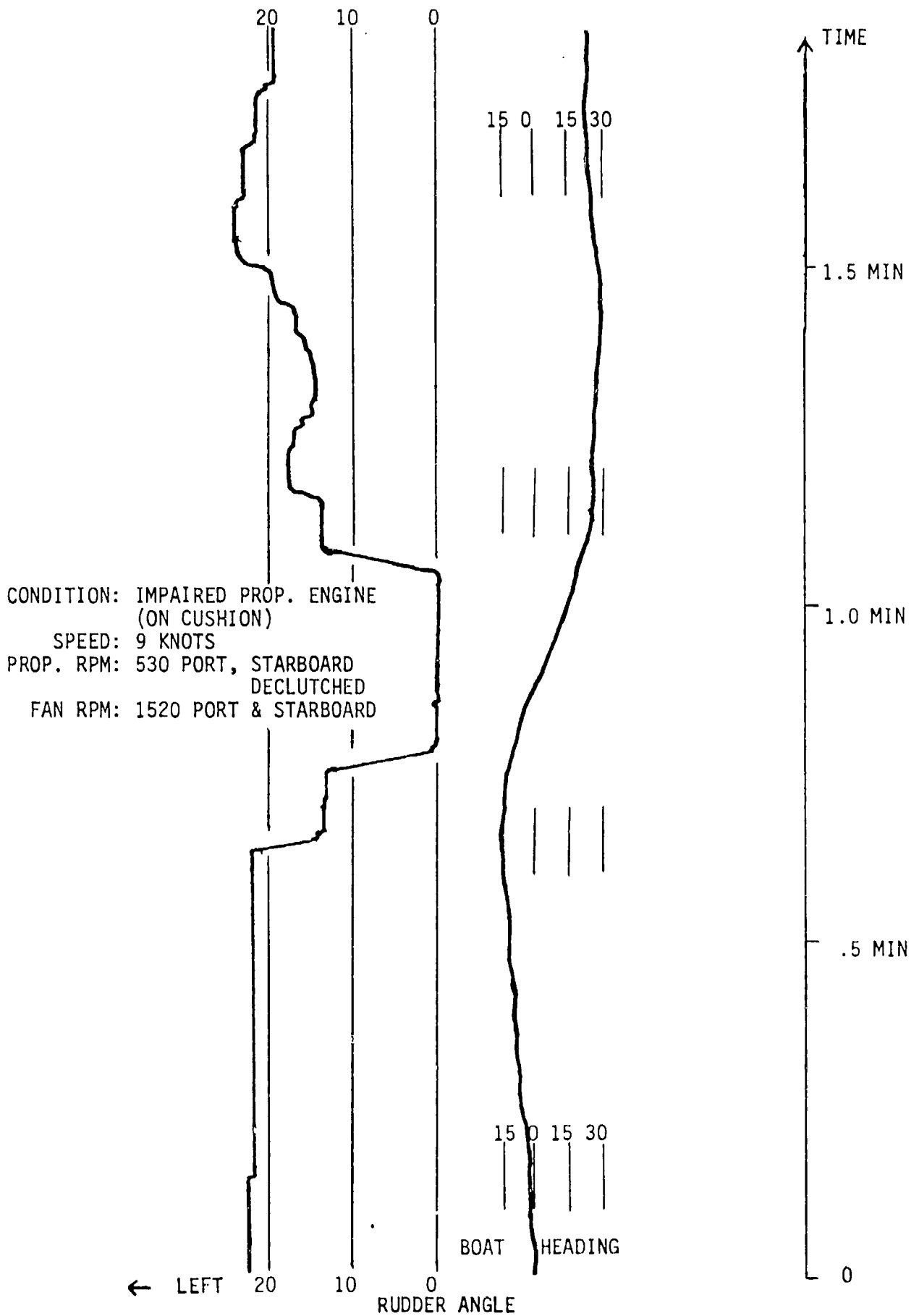

FIGURE 20. DIRECTIONAL STABILITY AT NORMAL LOW SPEED WITH IMPAIRED PROPULSION ENGINE (ON CUSHION)

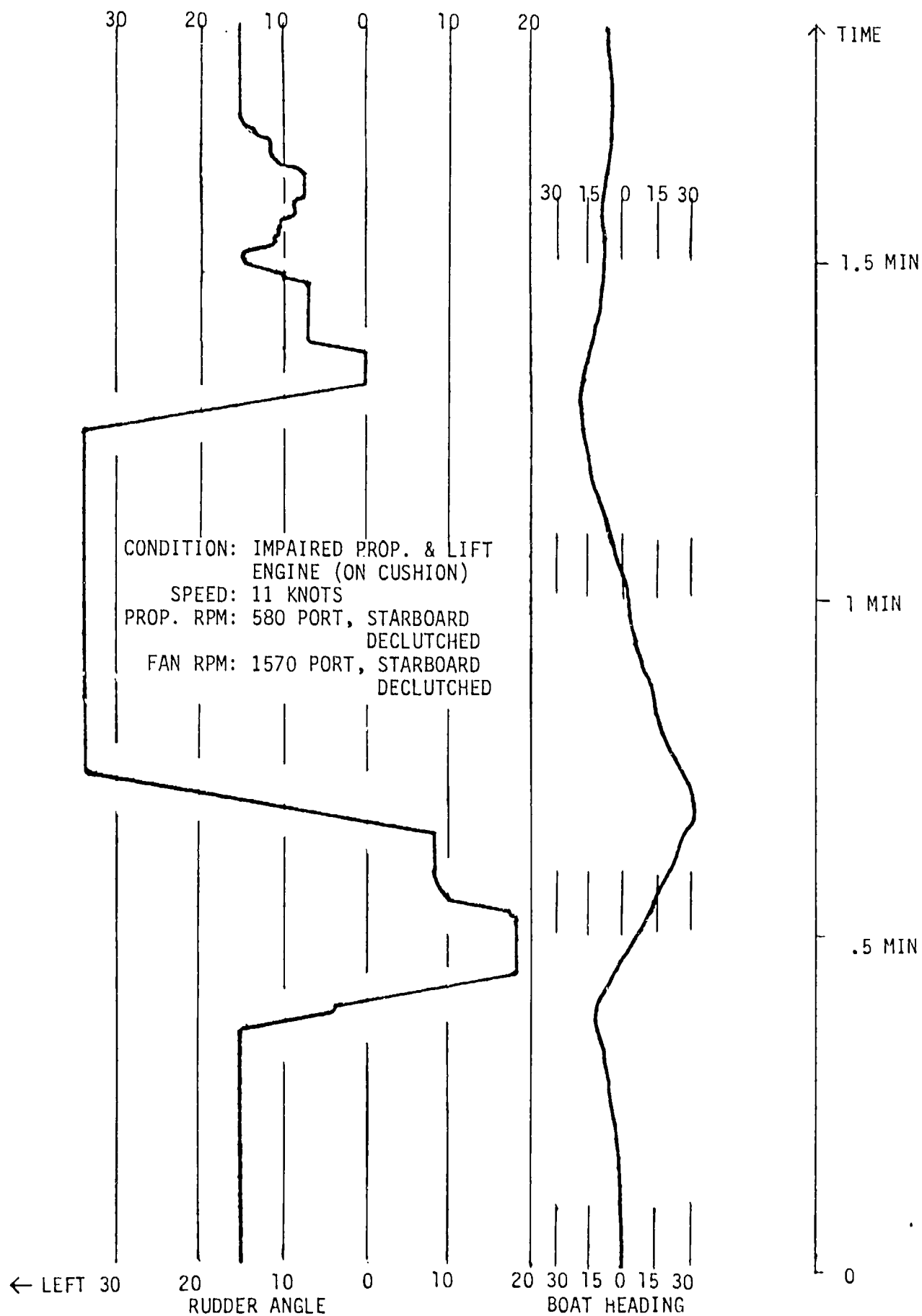

FIGURE 21. DIRECTIONAL STABILITY AT NORMAL LOW SPEED WITH IMPAIRED PROPULSION AND FAN ENGINE (ON CUSHION)

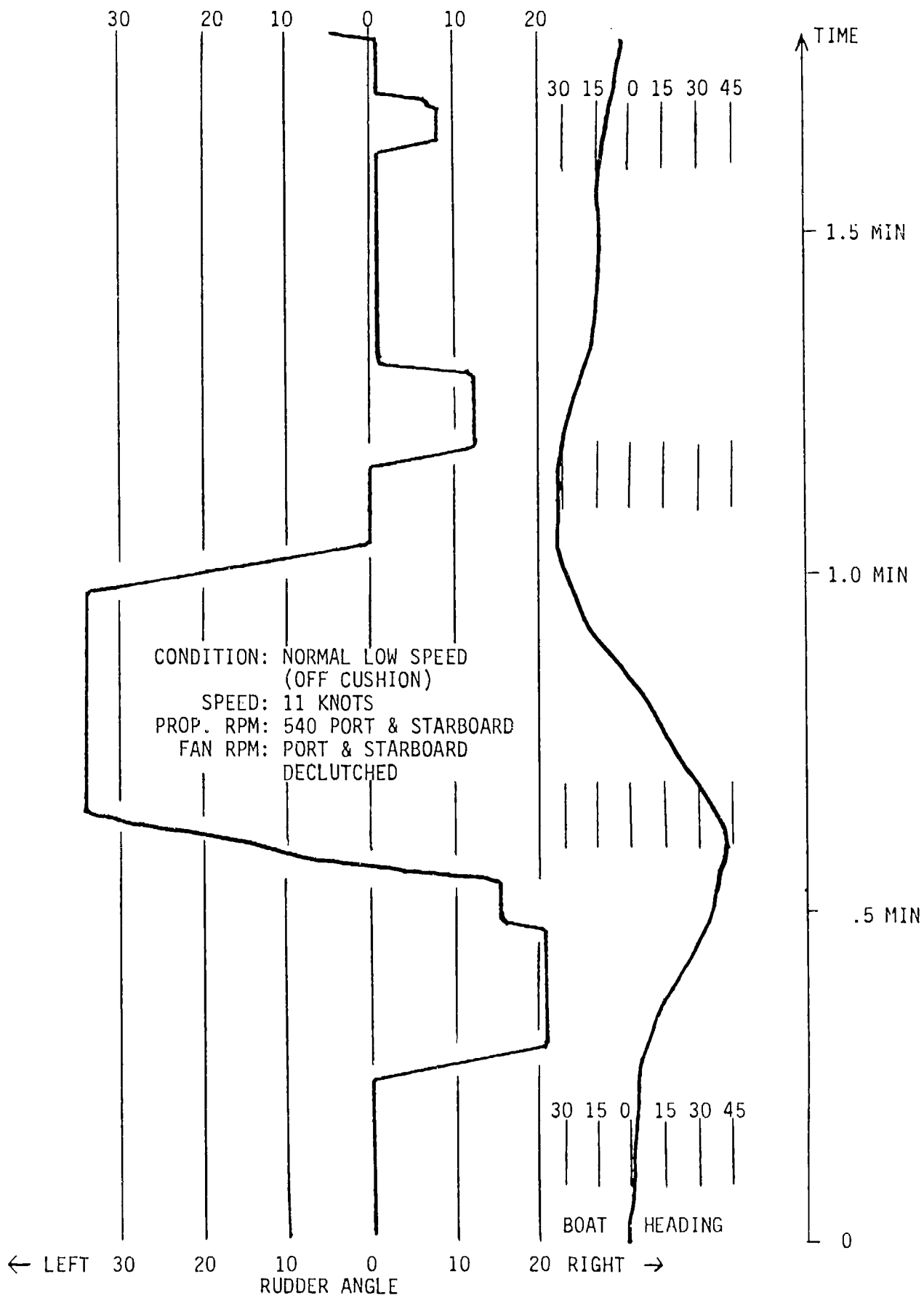

FIGURE 22. DIRECTIONAL STABILITY AT NORMAL LOW SPEED (OFF CUSHION)

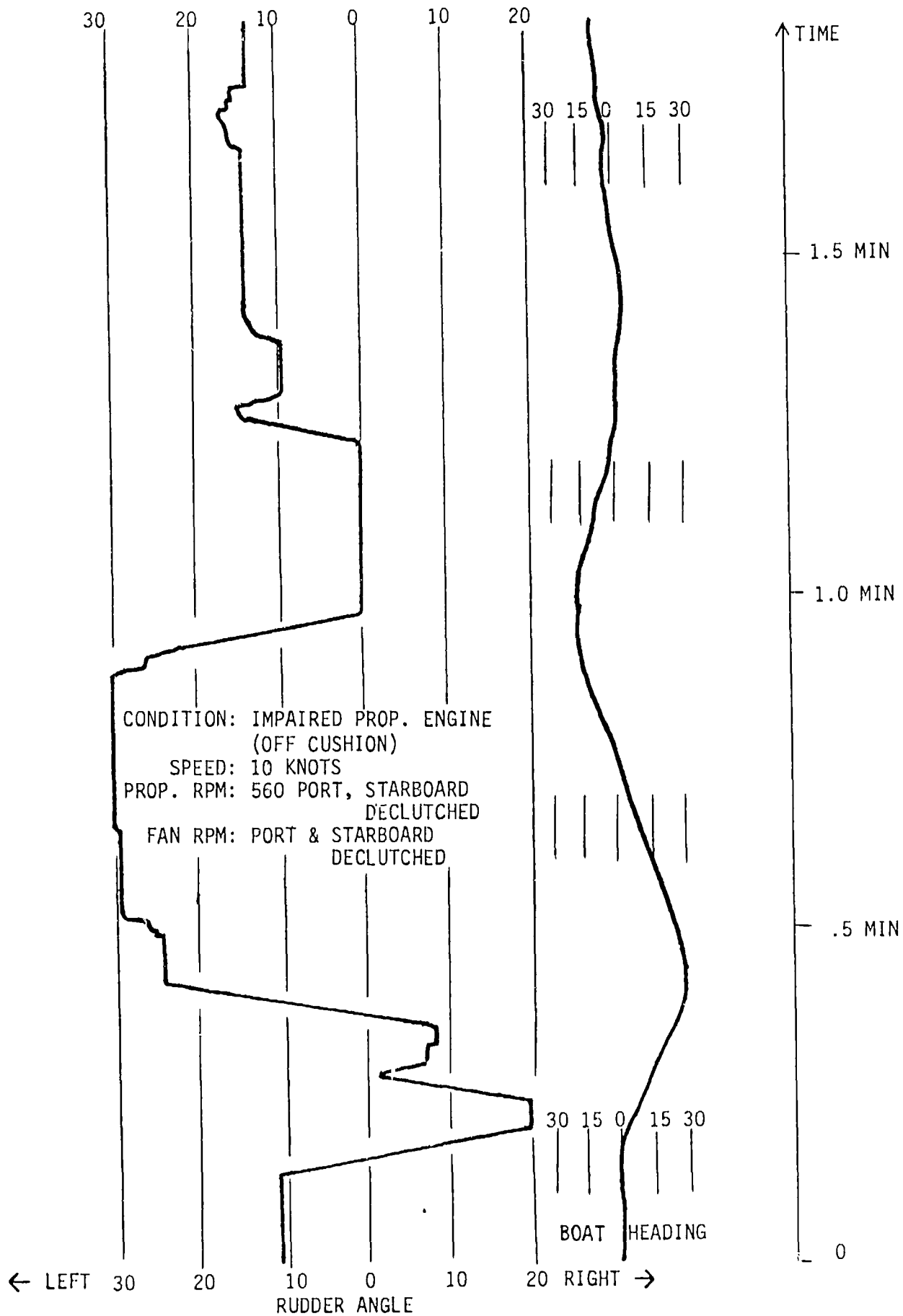

FIGURE 23. DIRECTIONAL STABILITY AT NORMAL LOW SPEED WITH IMPAIRED PROPULSION ENGINE (OFF CUSHION)

SPEED AT START OF MANEUVER: 19 KNOTS  
 SHAFT RPM: 690  
 FAN RPM: 1380  
 CONDITION: NORMAL ON CUSHION, MEDIUM SPEED

DIEUDONNE SPIRAL

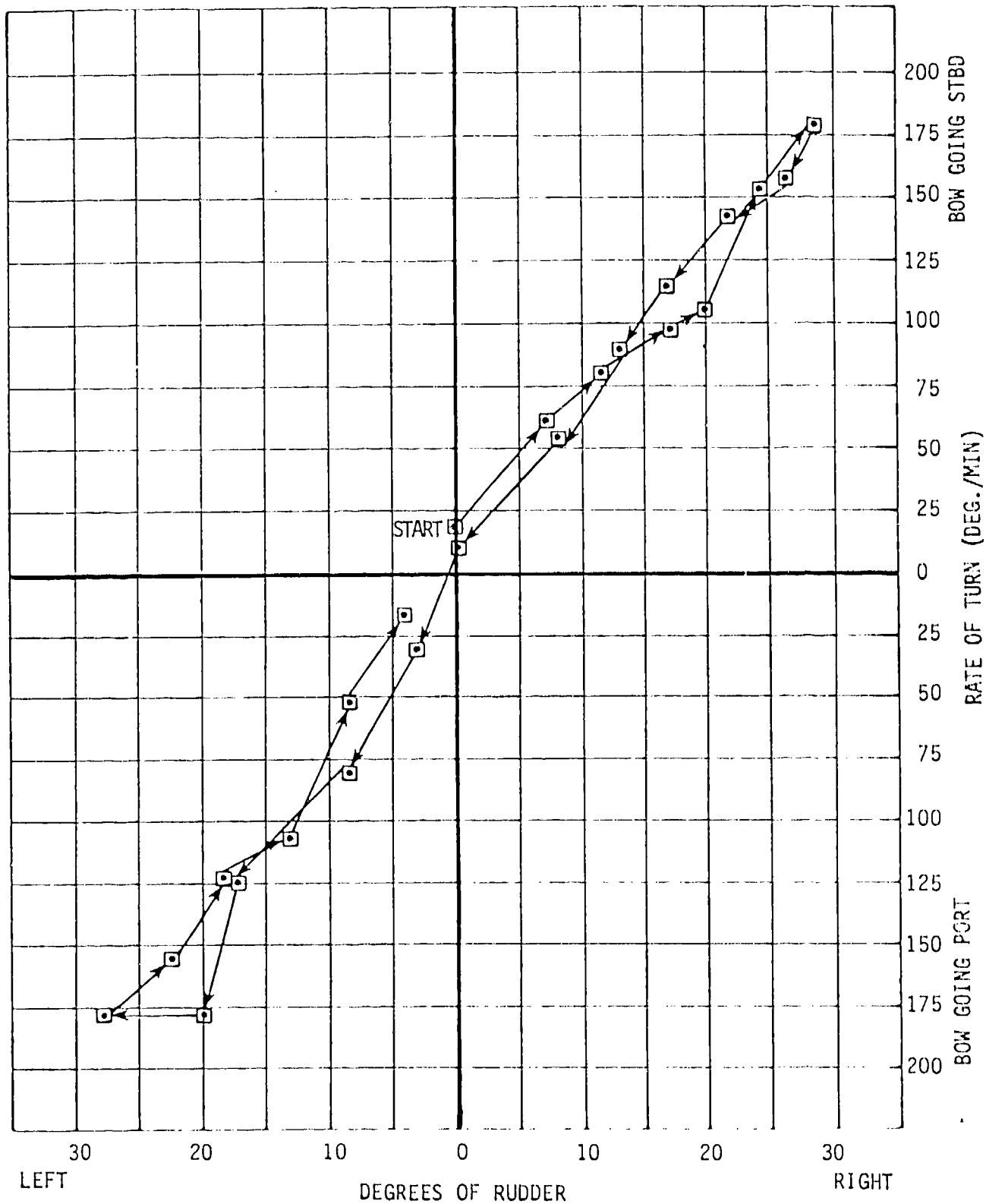

FIGURE 24. DIEUDONNE SPIRAL RESULTS FOR MEDIUM SPEED (ON CUSHION)

SPEED AT START OF MANEUVER: 30 KNOTS  
 SHAFT RPM: 880  
 FAN RPM: 1780  
 CONDITION: NORMAL ON CUSHION, HIGH SPEED

DIEUDONNE SPIRAL

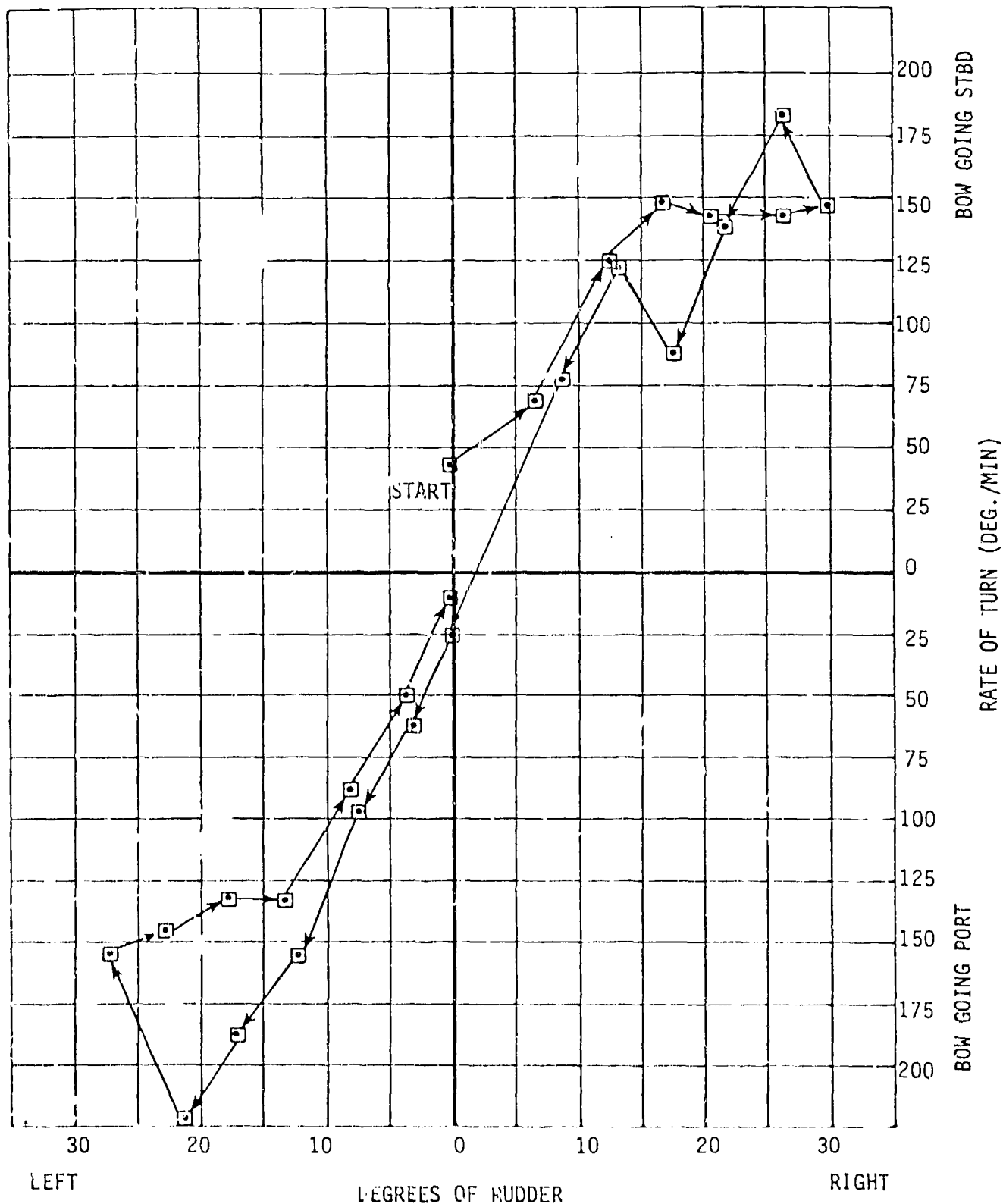

FIGURE 25. DIEUDONNE SPIRAL RESULTS FOR HIGH SPEED (ON CUSHION)

SPEED AT START OF MANEUVER: 19 KNOTS  
 SHAFT RPM: 690  
 FAN RPM: PORT 1550, STARBOARD DE-CLUTCHED  
 CONDITION: SIMULATED IMPAIRED LIFT ENGINE

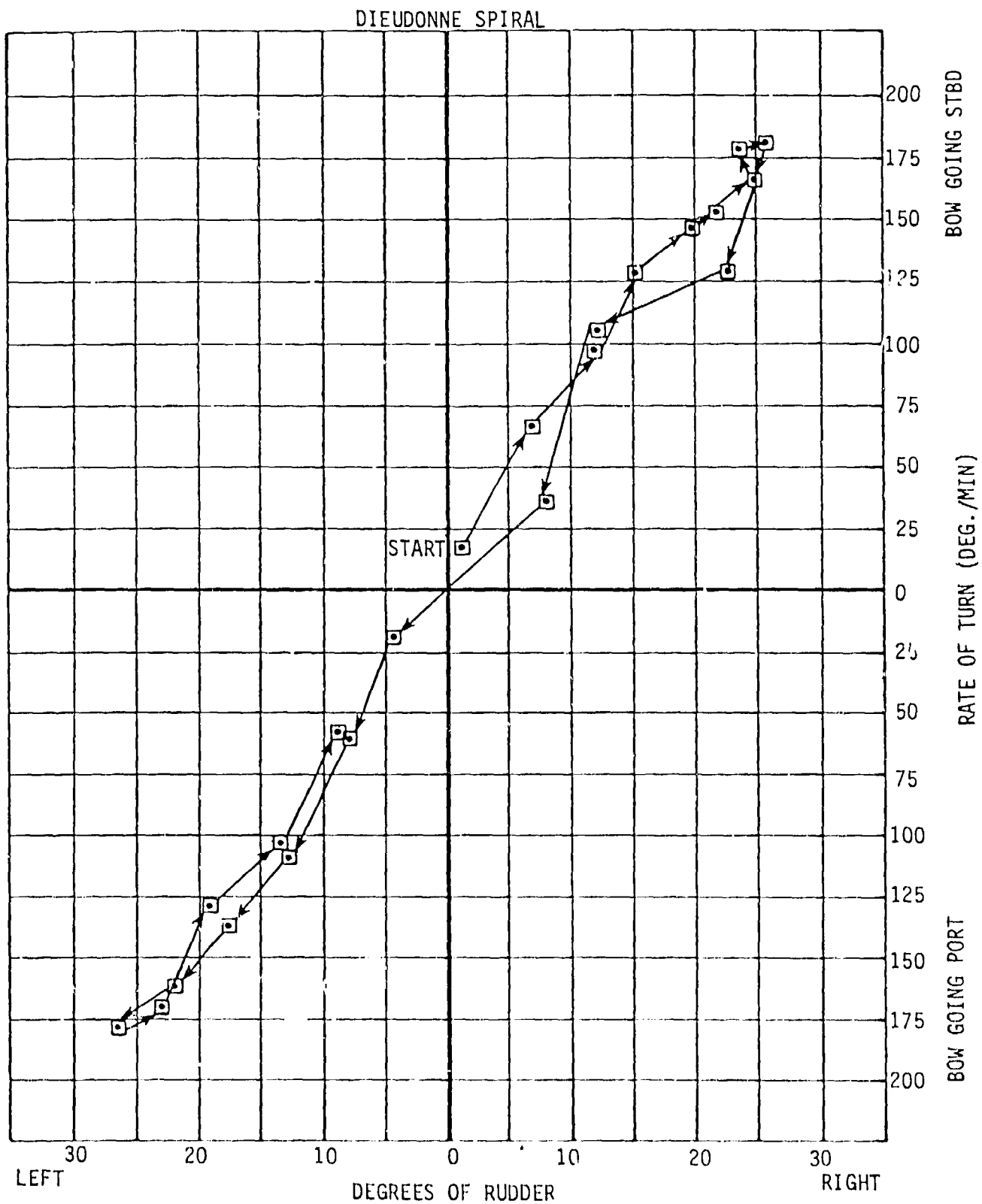

FIGURE 26. DIEUDONNE SPIRAL RESULTS FOR MEDIUM SPEED WITH IMPAIRED LIFT ENGINE (ON CUSHION)

SPEED AT START OF MANEUVER: 10 KNOTS  
 SHAFT RPM: PORT 580, STARBOARD DE-CLUTCHED  
 FAN RPM: 1530  
 CONDITION: SIMULATED IMPAIRED PROPULSION ENGINE

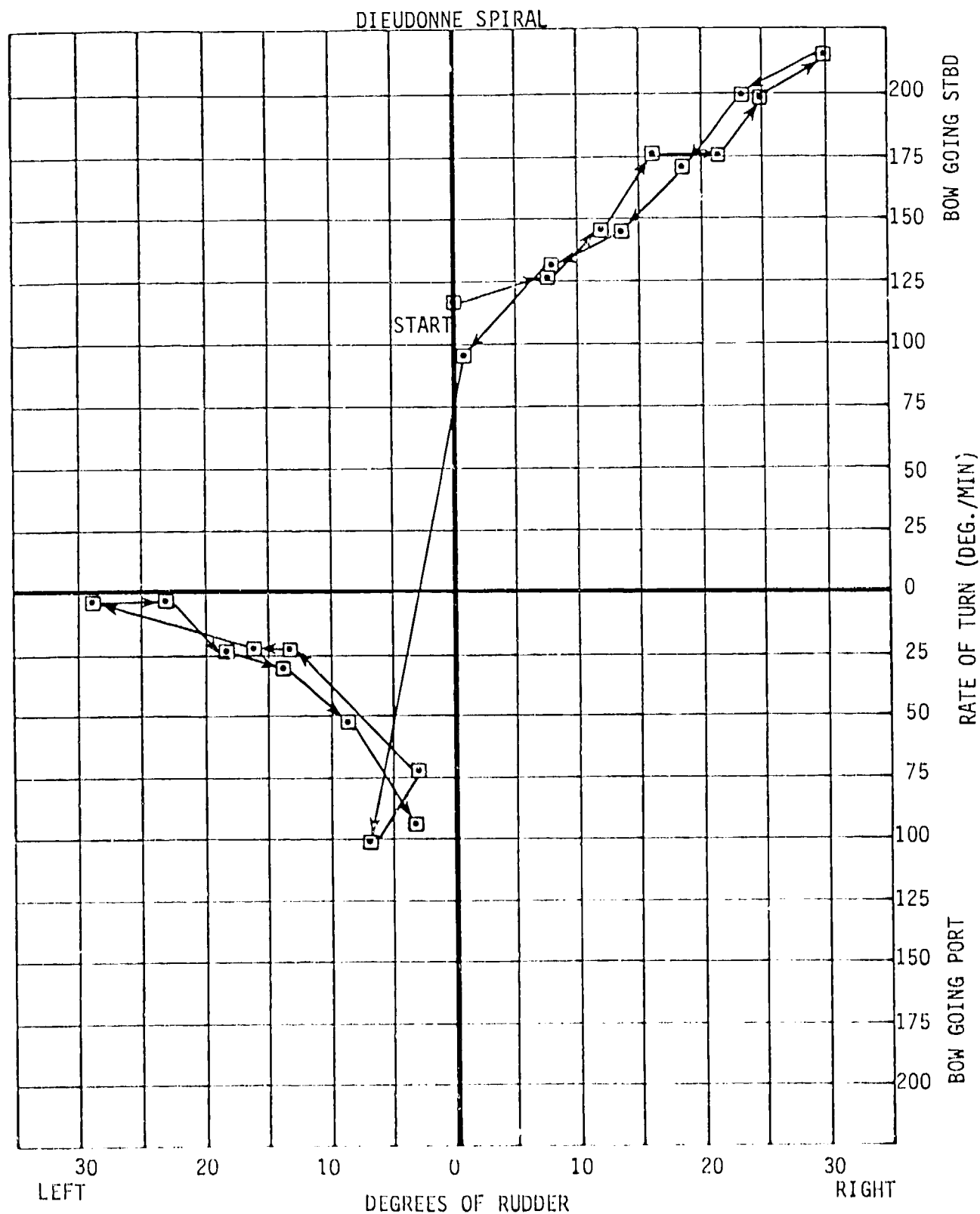

FIGURE 27. DIEUDONNE SPIRAL RESULTS FOR LOW SPEED WITH IMPAIRED PROPULSION ENGINE (ON CUSHION)

SPEED AT START OF MANEUVER: 11 KNOTS  
 SHAFT RPM: PORT 620, STARBOARD DE-CLUTCHED  
 FAN RPM: PORT 1550, STARBOARD DE-CLUTCHED  
 CONDITION: SIMULATED IMPAIRED PROPULSION AND LIFT ENGINE

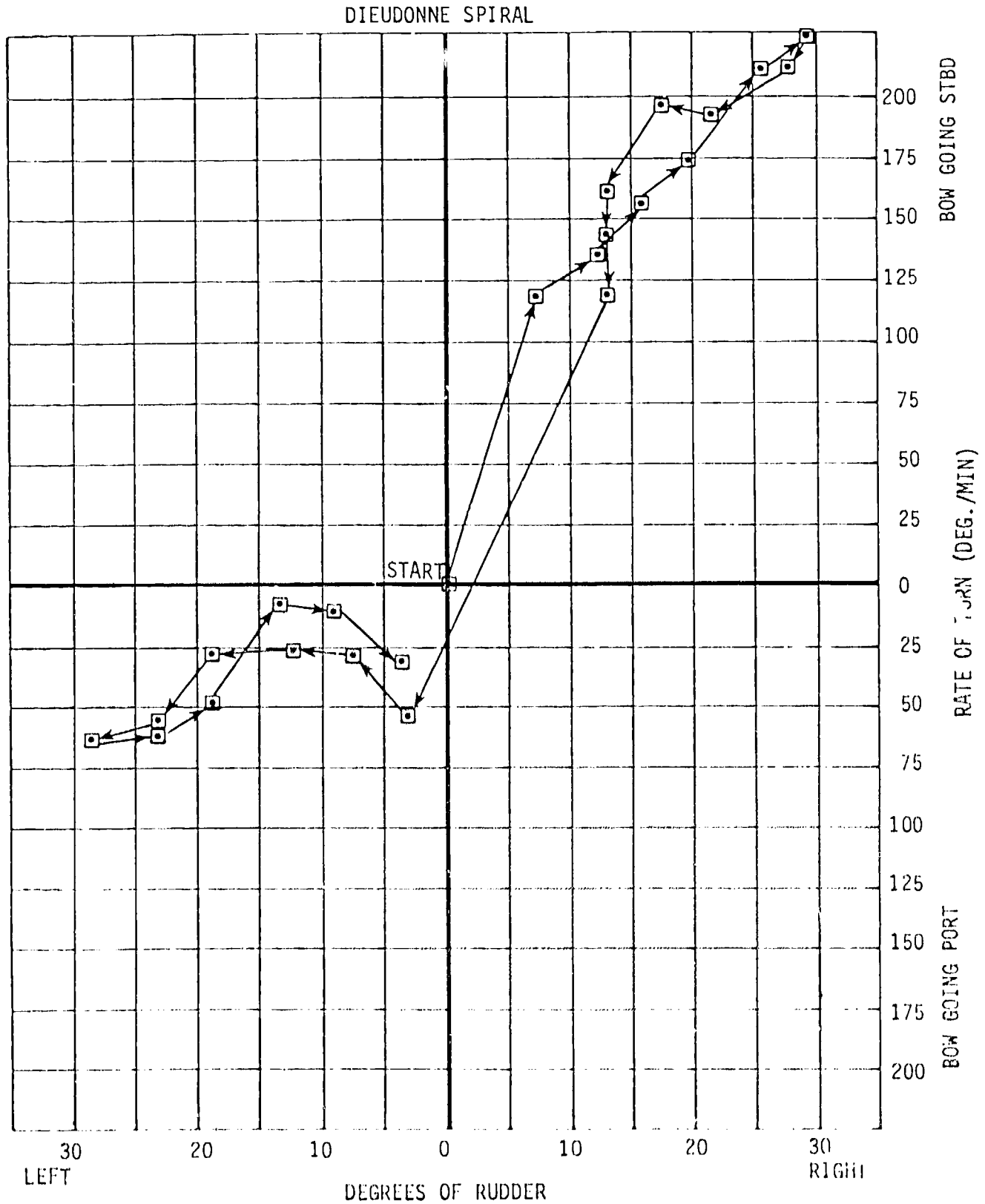

FIGURE 28. DIEUDONNE SPIRAL RESULTS FOR LOW SPEED WITH IMPAIRED PROPULSION AND LIFT ENGINE (ON CUSHION)

SPEED AT START OF MANEUVER: 14 KNOTS  
 SHAFT RPM: 550  
 FAN RPM: PORT AND STARBOARD DE-CLUTCHED  
 CONDITION: NORMAL OFF CUSHION

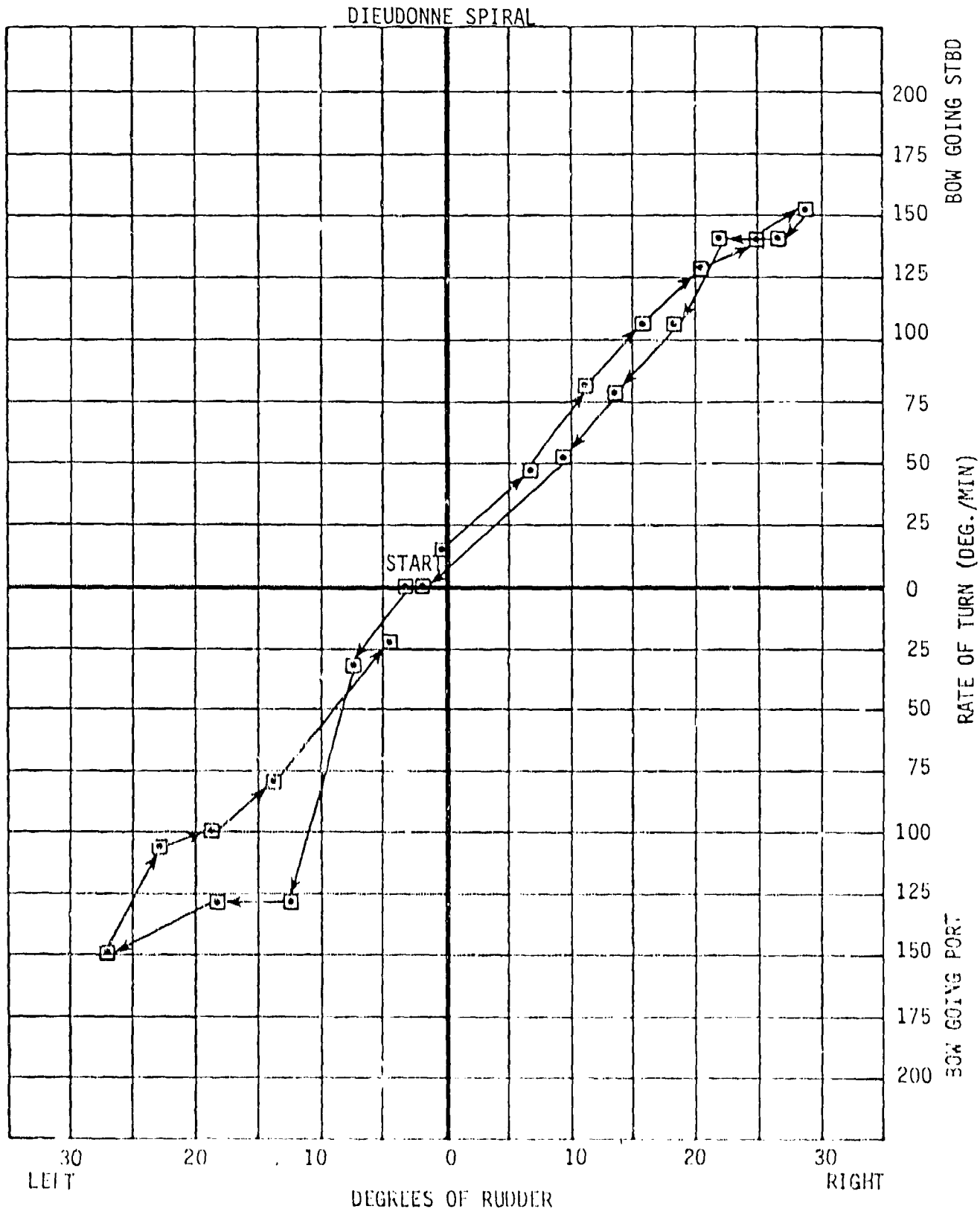

FIGURE 29. DIEUDONNE SPIRAL RESULTS FOR MEDIUM SPEED (OFF CUSHION)

SPEED AT START OF MANEUVER: 10 KNOTS  
 SHAFT RPM: PORT 580, STARBOARD DE-CLUTCHED  
 FAN RPM: PORT AND STARBOARD DE-CLUTCHED  
 CONDITION: SIMULATED IMPAIRED PROPULSION ENGINE, OFF CUSHION

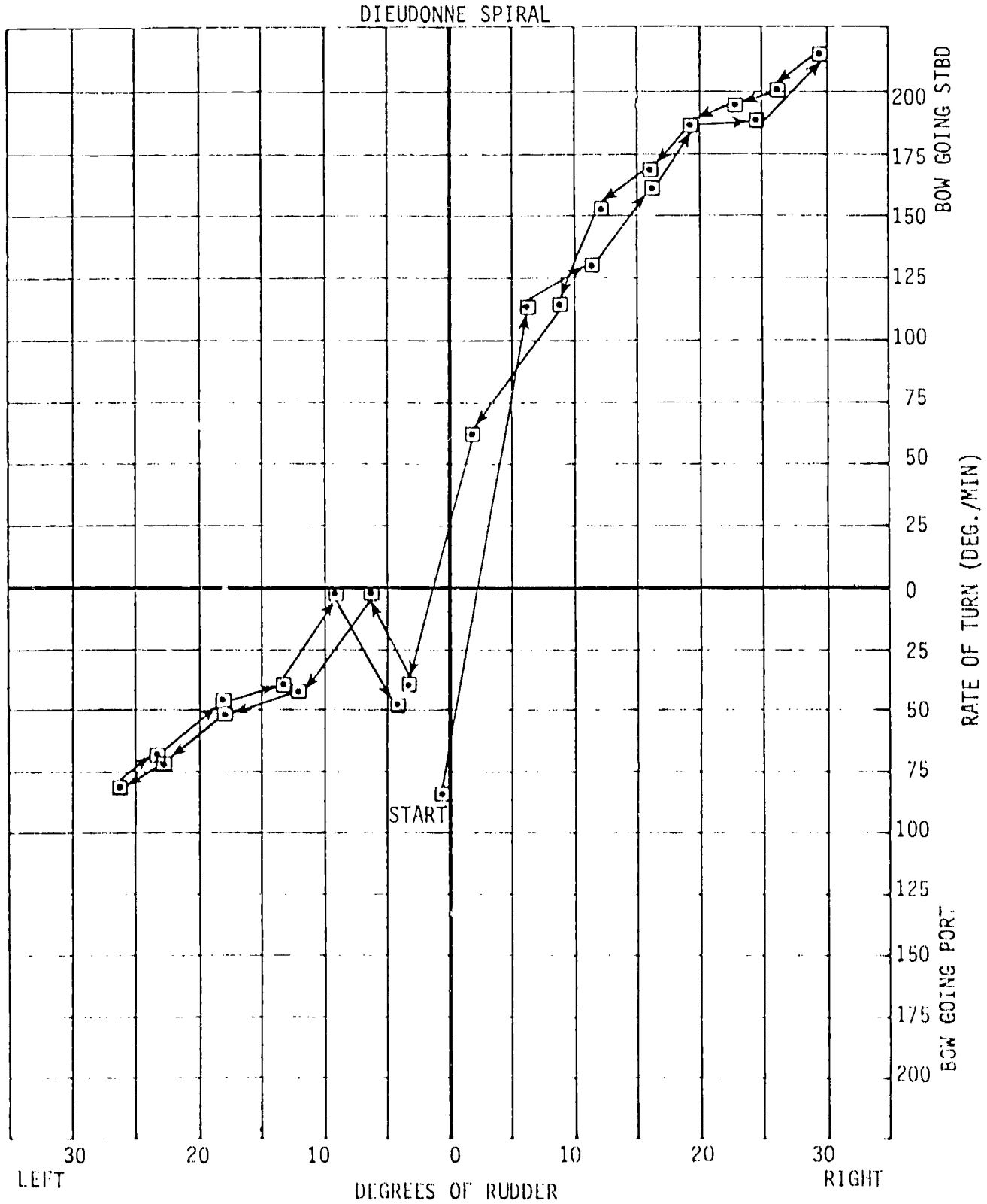

FIGURE 30. DIEUDONNE SPIRAL RESULTS FOR LOW SPEED WITH IMPAIRED PROPULSION ENGINE (OFF CUSHION)

## ACCELERATION-DECELERATION

The time required by the SES to accelerate to high speed and decelerate from high speed for several modes of operation was determined using time-history recordings from a tracking system. The test results are presented in table 8 and are the average of 2 or more events for each operating mode. The results show that if an operational requirement exists to rapidly accelerate from rest or low speed to high speed, the cushion pressure must be maintained sufficiently high to keep the aft seal clear of water. This condition is maintained with a minimum fan speed of approximately 600 rpm. The aft seal must be cleared before high speed operation or seal damage will result due to the large mass of water trapped within the seal bag geometry (see figure 3). The SES requires approximately three times as long to accelerate to high speed from the flooded seal status. There is only a small difference in decelerating to rest from high speed between maintaining and cutting fan power when cutting propulsion power. As would be expected, maintaining fan power while decelerating results in longer deceleration times.

TABLE 8

ACCELERATION - DECELERATION TESTS RESULTS			
TEST CONDITON	CRAFT SPEED - KNOTS		ELAPSED TIME - SEC
	INITIAL	FINAL	
AT REST WITH AFT SEAL CLEARED OF WATER (FAN RPM 1280), ACCELERATE TO HIGH SPEED - AVG. OF 4 EVENTS	0	29.3	79
AT REST WITH AFT SEAL FLOODED WITH WATER (FAN RPM 0), CLEAR SEAL OF WATER AND ACCELERATE TO HIGH SPEED - AVG. OF 2 EVENTS	0	25.9	204
ACCELERATE TO HIGH SPEED FROM AN AHEAD IDLE CONDITION (FAN RPM 590, PROP SHAFT RPM 250), - AVG. OF 2 EVENTS	6.3	26.6	74
DECELERATE FROM HIGH SPEED TO REST BY CUTTING POWER TO BOTH PROPULSION AND FAN ENGINES - AVG. OF 3 EVENTS	28.3	0	15
DECELERATE FROM HIGH SPEED TO REST BY CUTTING POWER TO PROPULSION ENGINES ONLY (FAN RPM HELD AT 1590), - AVG. OF 2 EVENTS	27.0	0	18

## NOISE

Ambient airborne noise level was measured at seven locations on the SES for the periods of advance and at rest with only the fans operating. Measurements were made with a 1/3-octave band analyzer and the results are reported in 1/3-octave frequency bands from 0 to 16 kHz. All pass and A-weighted, which is the Speech Interference Level (SIL), are presented in tabular form in the results. The results are presented in figures 31 through 40 as noise level, in dB, for each 1/3-octave band center frequency with the SES operating at low, medium, and high speed and at two fan speeds at rest. The Occupational Safety and Health Administration (OSHA) occupational safety and health limits (reference 6) limiting curve is superimposed over the results and the equivalent dBA (A-weighted) value and the hour-per-day exposure limit is listed. Pilot house, passenger compartment, and galley area noise levels are within safe limits where ear protection is not required for up to 8 hours per day exposure (figures 31 to 33). These three areas are also below the OSHA 24-hour exposure limit of 82 dBA. Figure 34 is medium speed noise level in the galley area with the centerline passageway door closed. Comparing figure 34 with the medium speed results in figure 33 shows nearly identical results, indicating noise is reaching this area primarily via structural paths. Figures 35 through 38 show that ear protection should be employed in the engineroom and all outside on-deck locations. Figures 39 and 40 present noise levels in the passenger compartment and outside on the main afterdeck with the SES at rest (main engines secured) and the fans operating at the same rpm as when underway at low and medium speed. Comparing these results with underway results indicates that above maindeck level (inside or outside the deckhouse) the primary source of noise is from the lift fans.

SYMBOL	SPEED (KNOTS)	NOISE LEVEL - db	
		ALL PASS	A-WEIGHTED
□	33	101	72
○	22	95	67
△	12	90	67

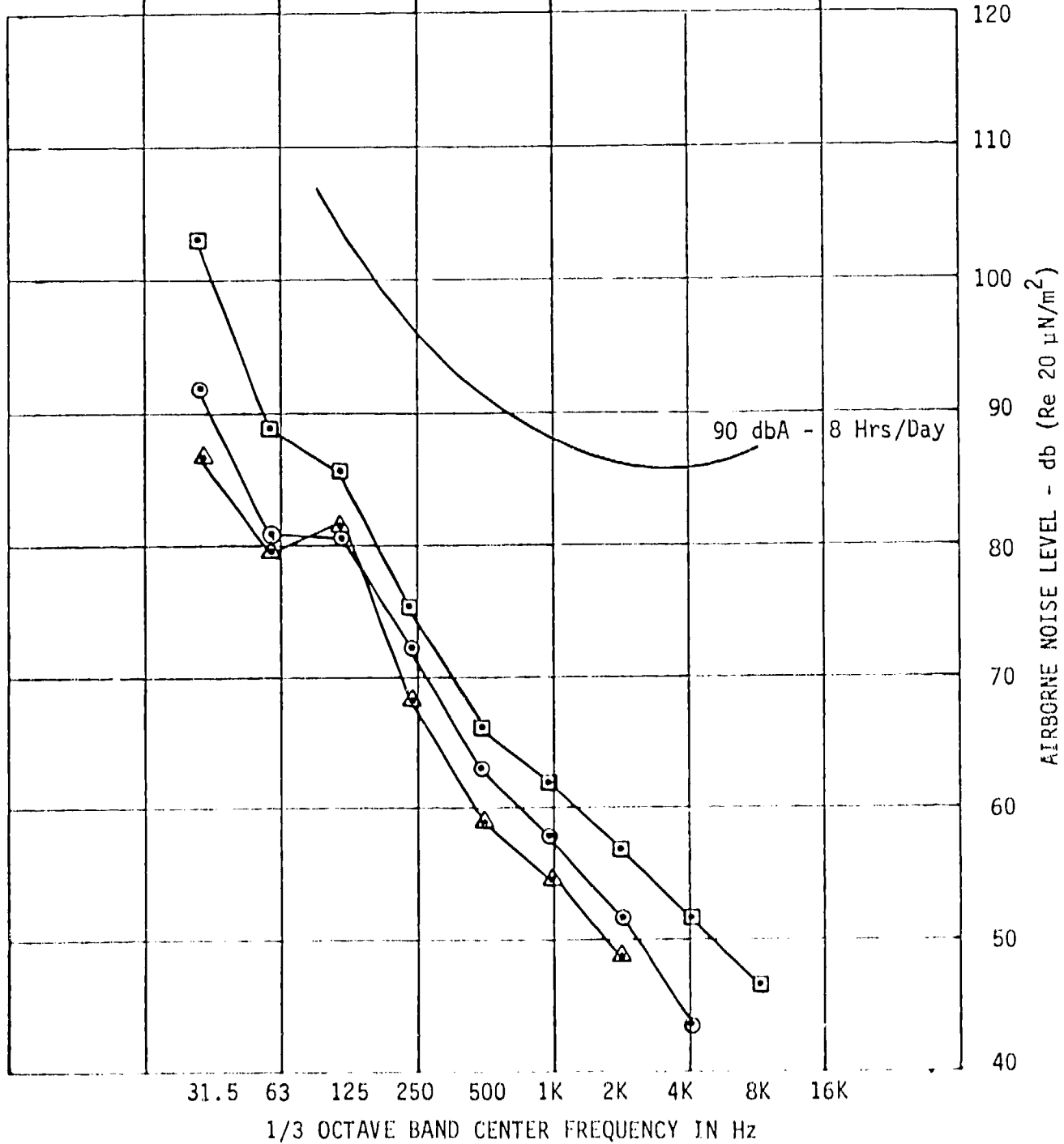

FIGURE 31. AMBIENT NOISE LEVEL - CENTER OF PILOT HOUSE

SYMBOL	SPEED (KNOTS)	NOISE LEVEL - db	
		ALL PASS	A-WEIGHTED
□	33	99	76
○	22	95	75
△	12	91	71

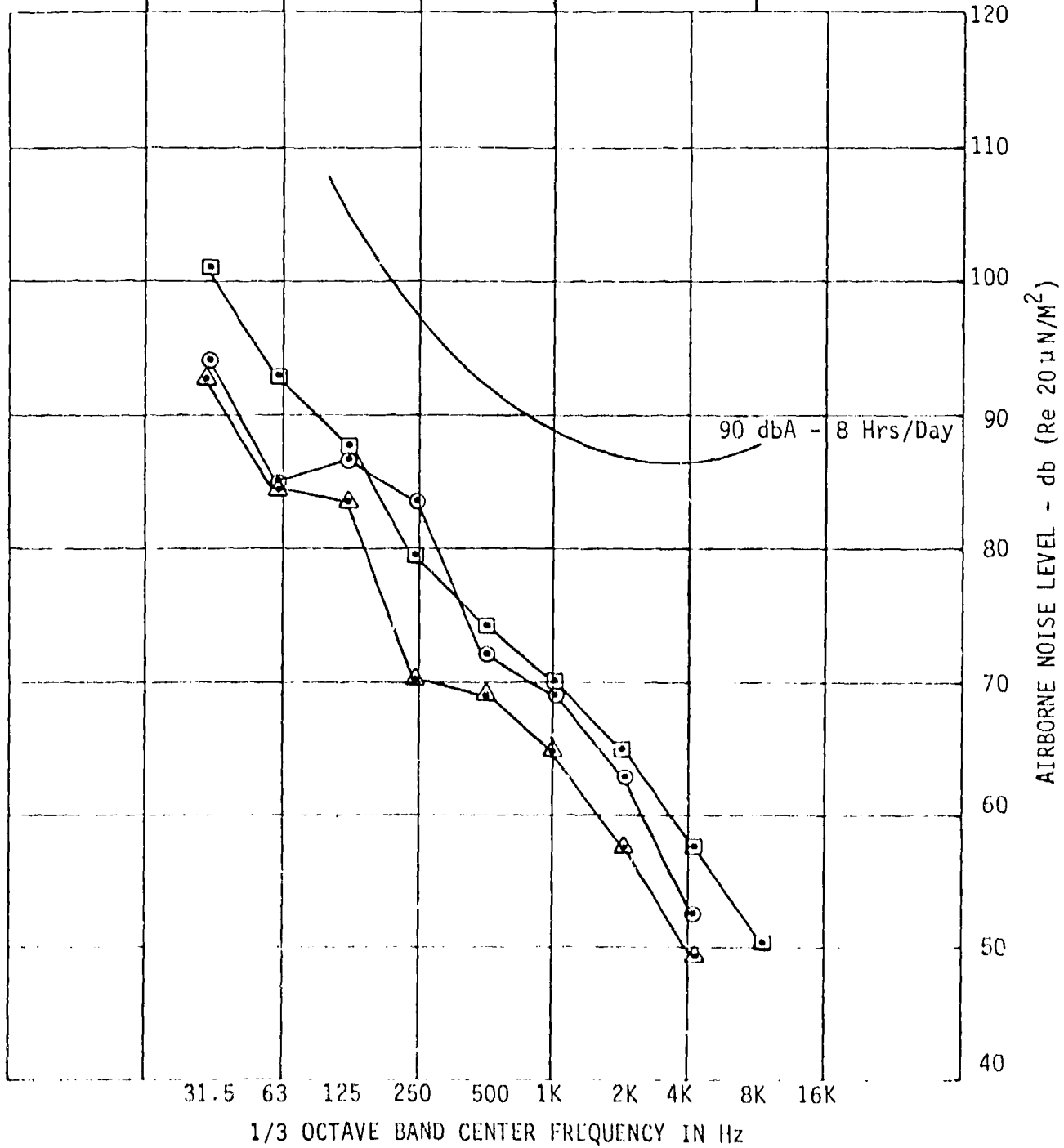

FIGURE 32. AMBIENT NOISE LEVEL - CENTER OF PASSENGER COMPARTMENT - MAINDECK

SYMBOL	SPEED (KNOTS)	NOISE LEVEL - db	
		ALL PASS	A-WEIGHTED
□	33	99	82
○	22	92	78
△	12	89	75

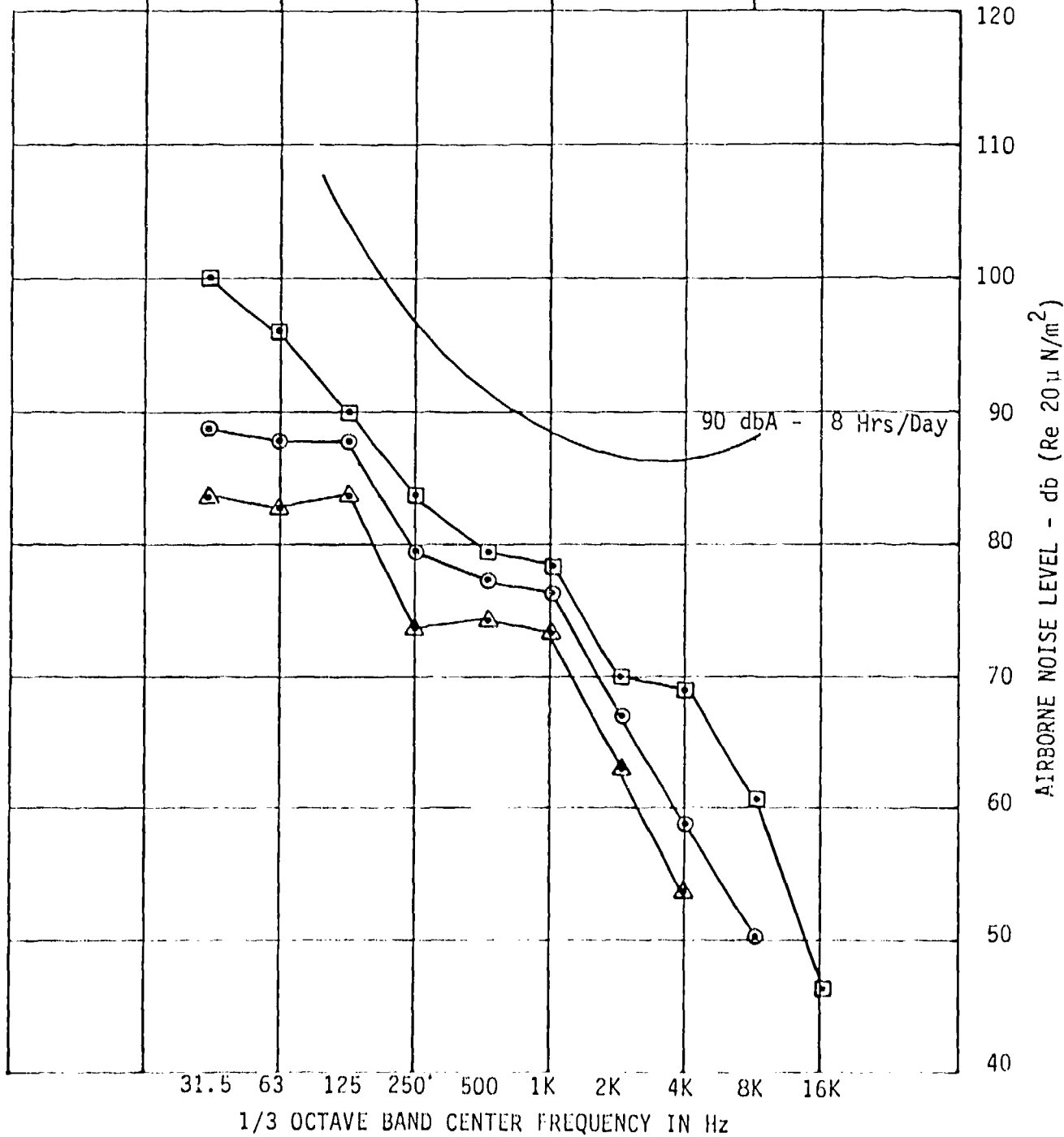

FIGURE 33. AMBIENT NOISE LEVEL - CENTER OF GALLEY AREA - CENTERLINE PASSAGEWAY - DOOR OPEN

SYMBOL	SPEED (KNOTS)	NOISE LEVEL - db	
		ALL PASS	A-WEIGHTED
□	33		
○	22	92	78
△	12		

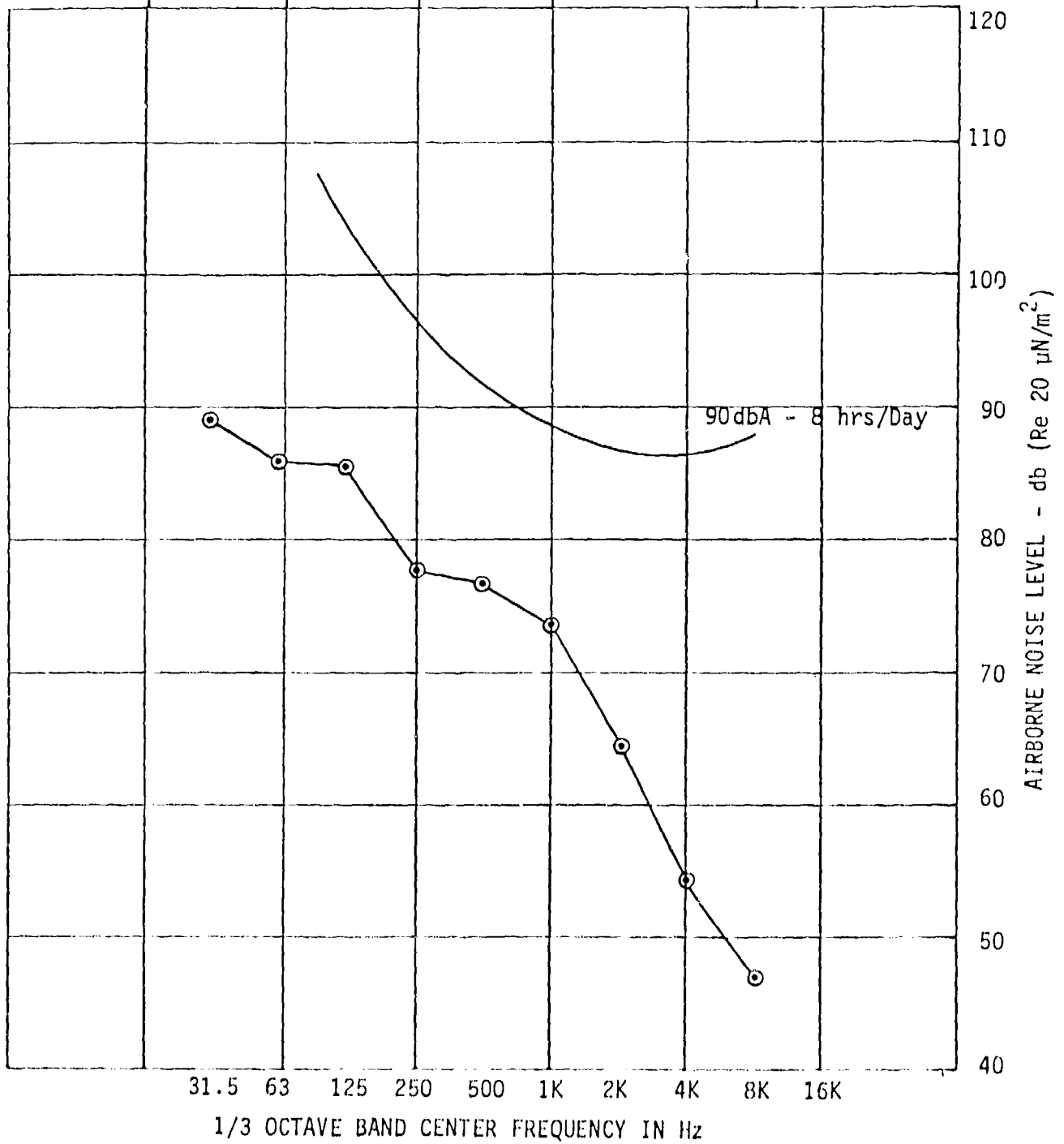

FIGURE 34. AMBIENT NOISE LEVEL - CENTER OF GALLEY AREA - CENTER LINE PASSAGEWAY - DOOR CLOSED

SYMBOL	SPEED (KNOTS)	NOISE LEVEL - db	
		ALL PASS	A-WEIGHTED
□	33	116	111
○	22	112	109
△	12	111	108

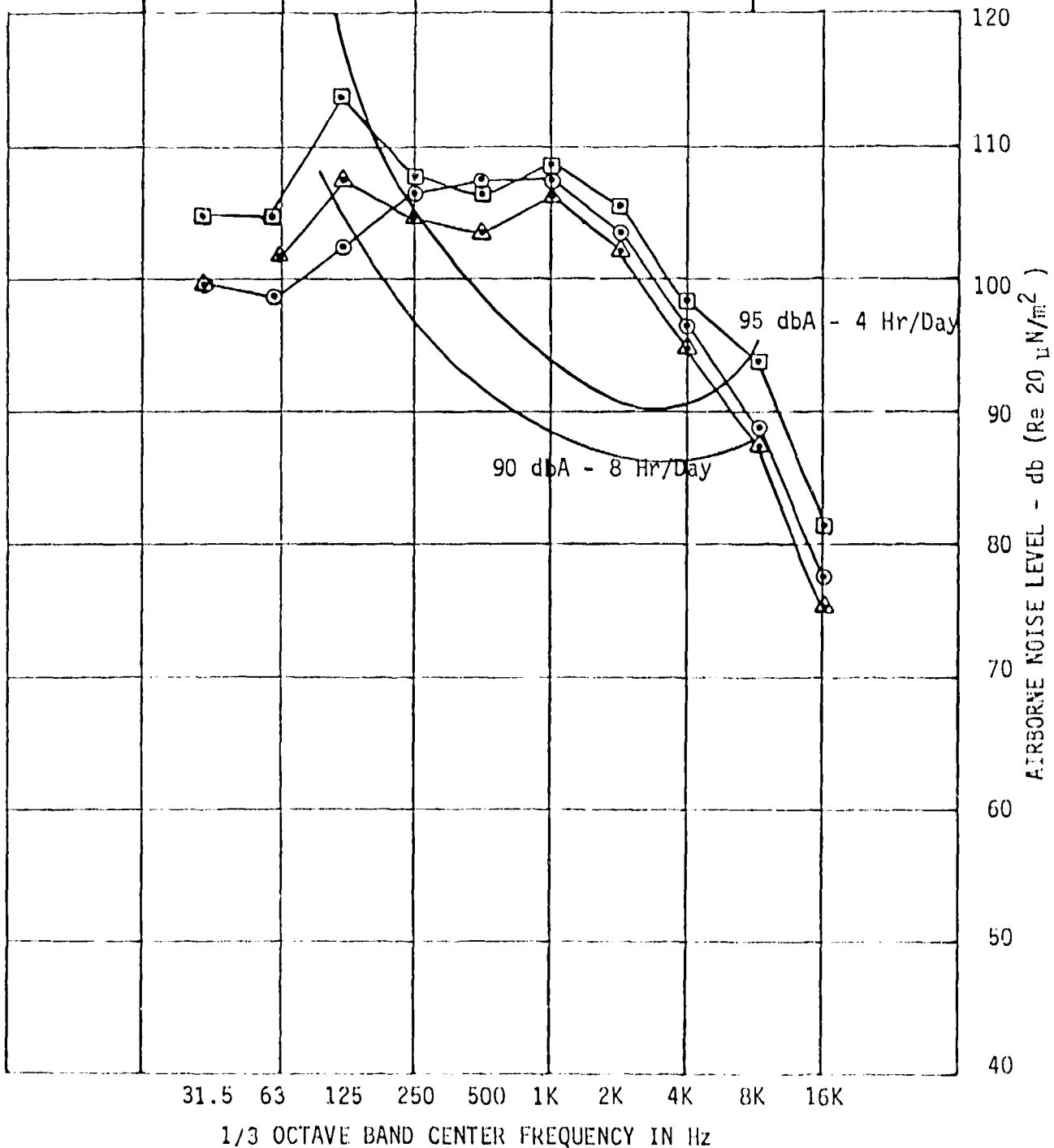

FIGURE 35. AMBIENT NOISE LEVEL. - ENGINE ROOM - MIDSHIP

SYMBOL	SPEED (KNOTS)	NOISE LEVEL - db	
		ALL PASS	A-WEIGHTED
□	33	109	88
○	22	100	86
△	12	94	79

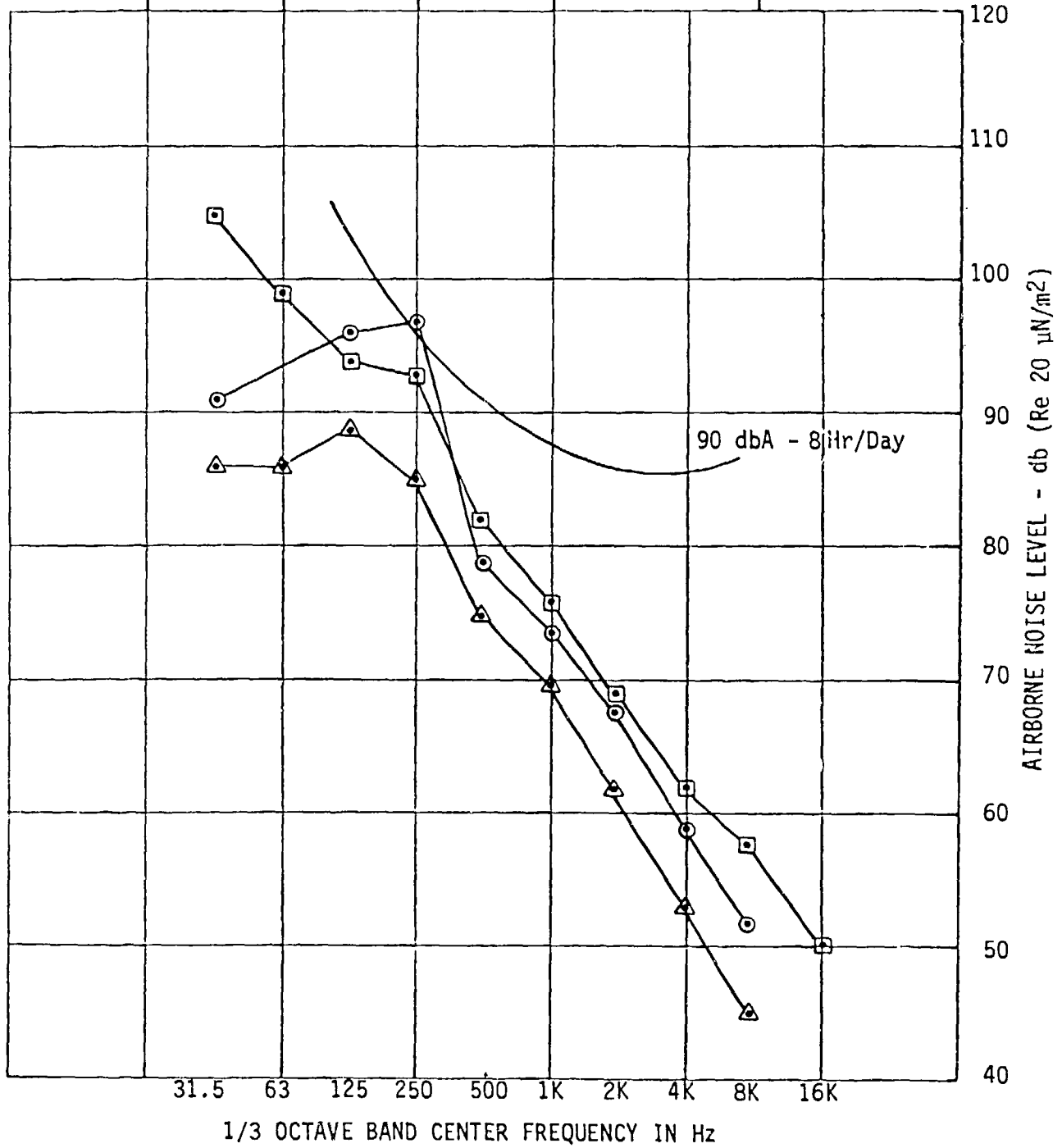

FIGURE 36. AMBIENT NOISE LEVEL - OUTSIDE - CENTER MAIN FOREDECK

SYMBOL	SPEED (KNOTS)	NOISE LEVEL - db	
		ALL PASS	A-WEIGHTED
□	33	112	102
○	22	106	95
△	12	103	93

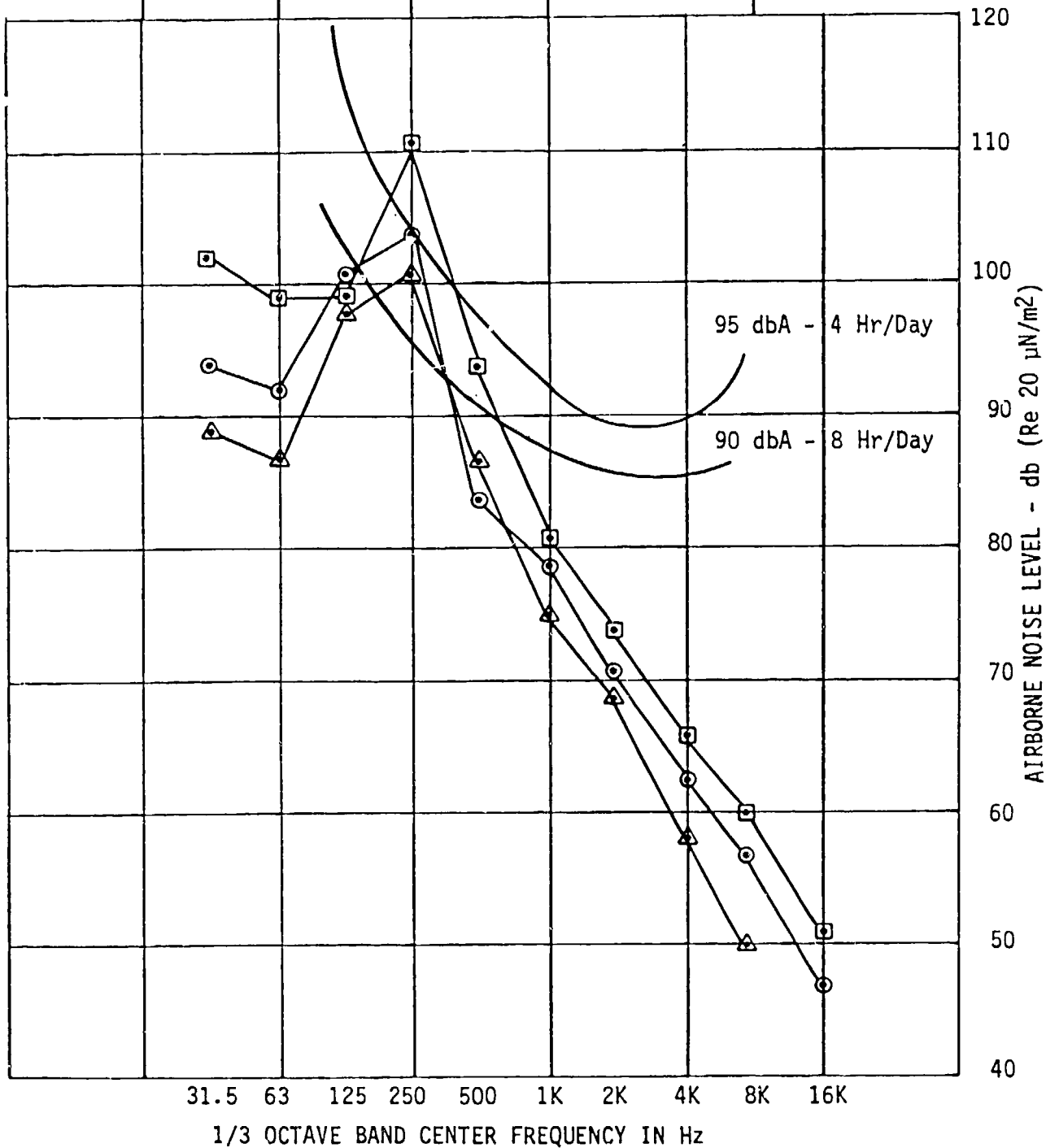

FIGURE 37. AMBIENT NOISE LEVEL - OUTSIDE - MAINDECK - MIDSHIP

SYMBOL	SPEED (KNOTS)	NOISE LEVEL - db	
		ALL PASS	A-WEIGHTED
□	33	113	97
○	22	104	93
△	12	103	93

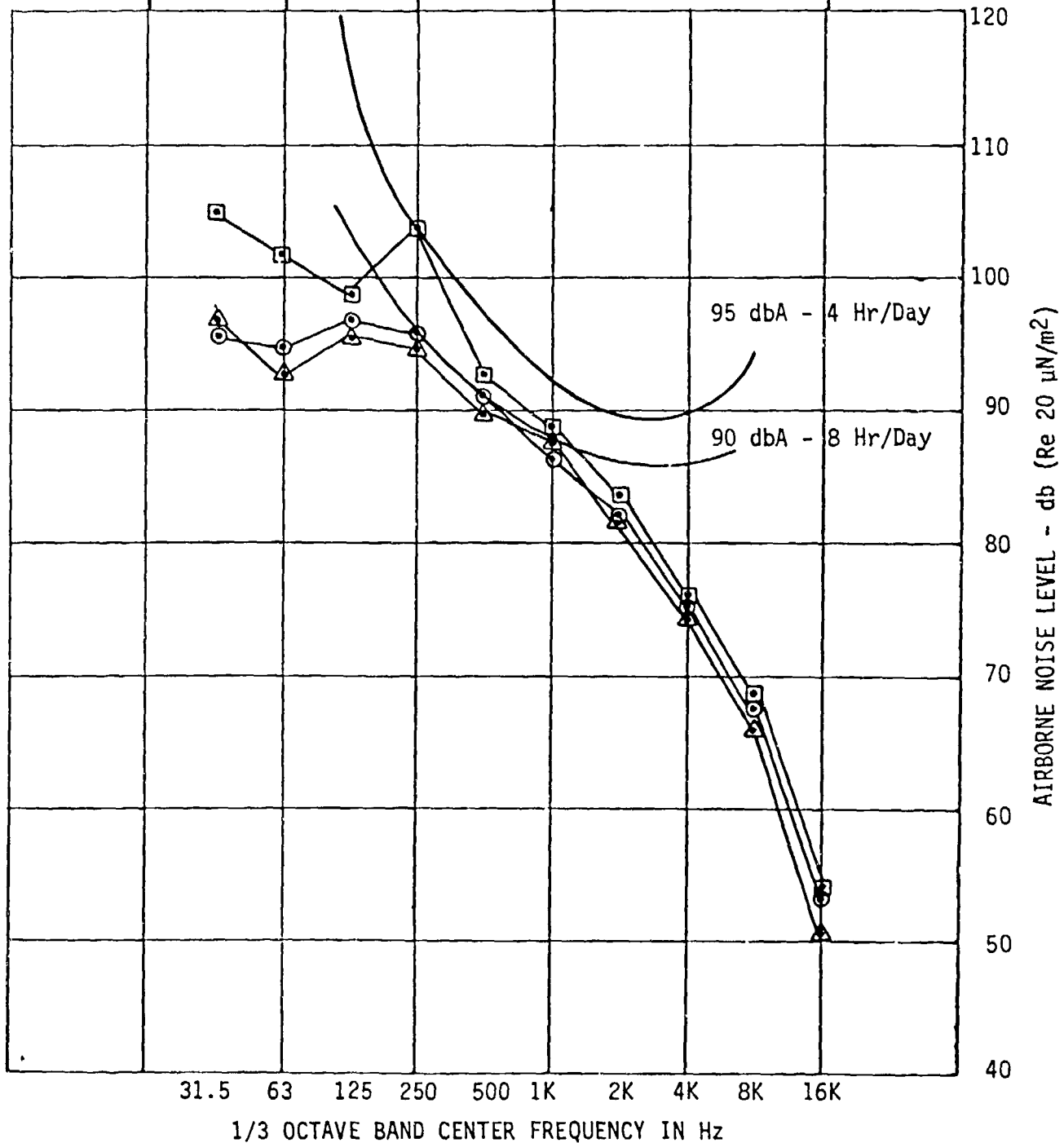

FIGURE 38. AMBIENT NOISE LEVEL - OUTSIDE - CENTER MAIN AFTERDECK

SYMBOL	SPEED (KNOTS)	FAN (RPM)	NOISE LEVEL - db	
			ALL PASS	A-WEIGHTED
◇	0	1490	96	68
◻	0	1285	88	68

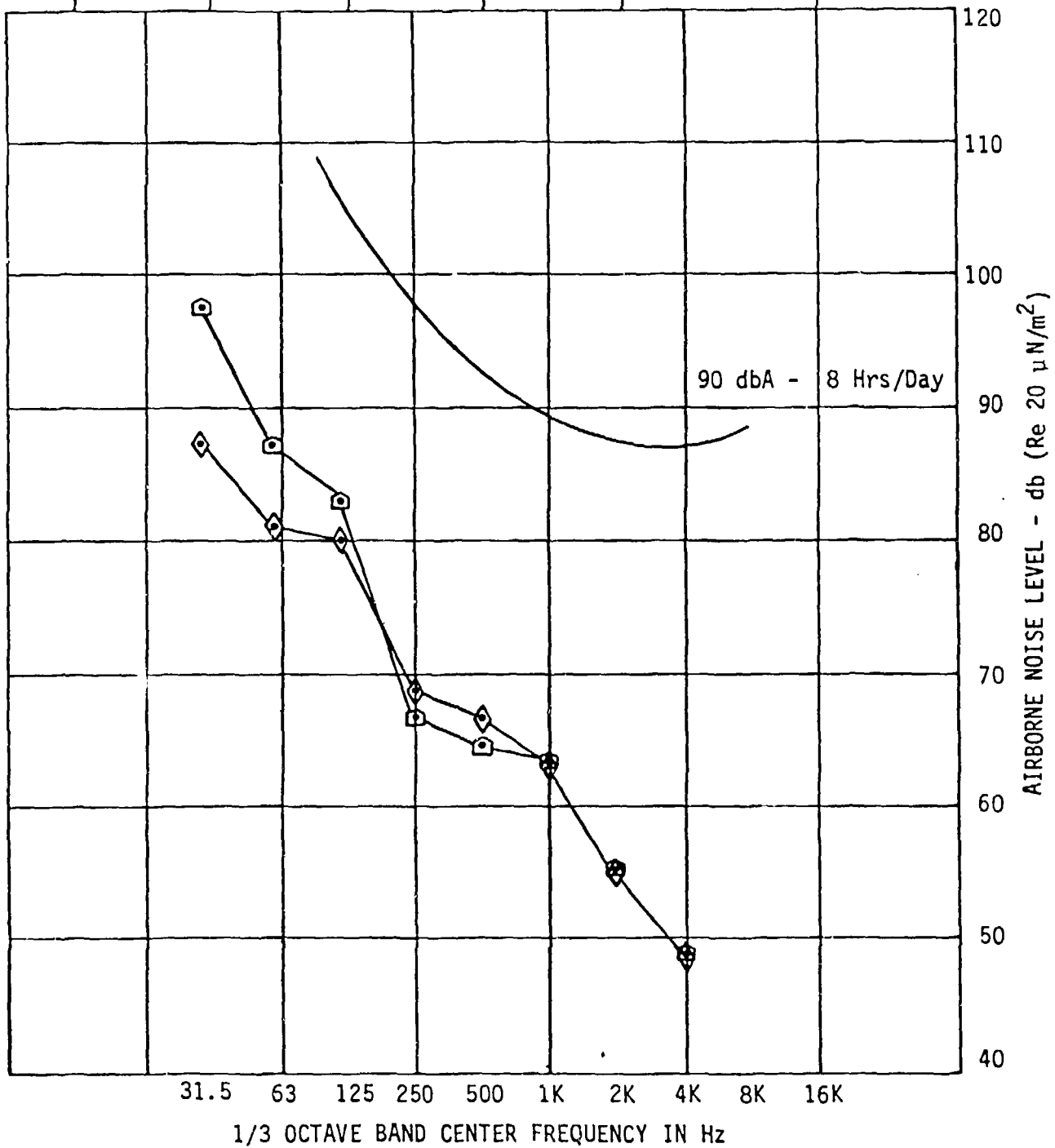

FIGURE 39. AMBIENT NOISE LEVEL - CENTER OF PASSENGER COMPARTMENT - FANS ONLY

SYMBOL	SPEED (KNOTS)	FAN (RPM)	NOISE LEVEL - db	
			ALL PASS	A-WEIGHTED
◇	0	1490	103	92
◻	0	1285	104	91

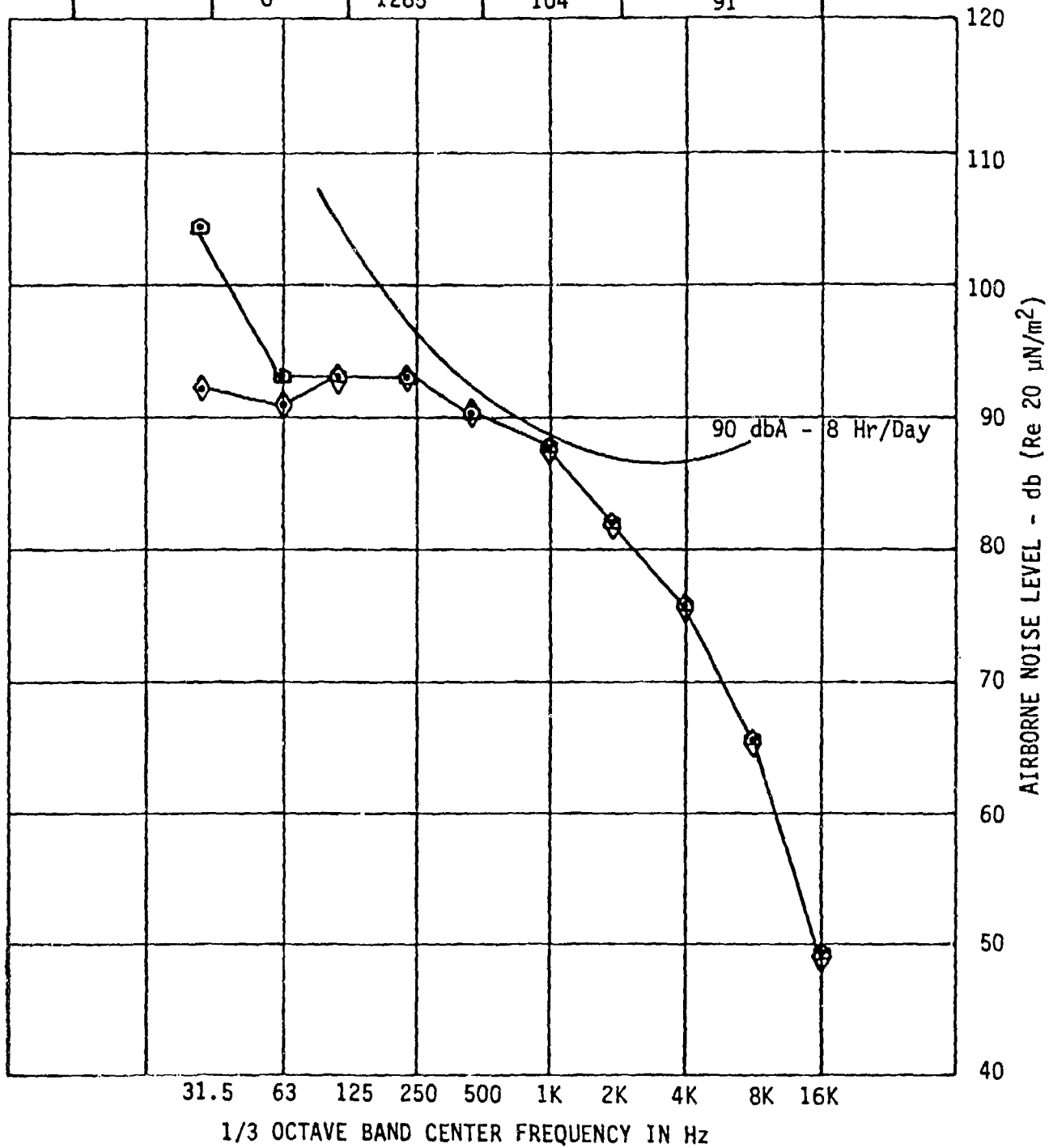

FIGURE 40. AMBIENT NOISE LEVEL - OUTSIDE - CENTER MAIN AFTERDECK - FANS ONLY

## WAKE HEIGHT

The height of the maximum wave(s) in the wake of the SES was measured at a point 150 feet from the straight path of the craft. Measurements were made with a calibrated wave buoy as the SES passed in an otherwise calm sea at low, medium, and high speed both on and off cushion. The wake height results are presented in table 9. The size of the wake was found to be nearly independent of speed at speeds higher than 6 knots. At low speeds where there is an option to operate either on or off cushion, on-cushion operation results in slightly less wake.

TABLE 9. 110 FT. SES WAKE WAVE MEASUREMENT  
FOR VARIOUS SPEEDS AND CONDITIONS

APPROX. SPEED KTS.	SHAFT RPM	FAN RPM	MAX. WAKE WAVE SIZE*	
			FROM MEAN, FT.	PEAK TO TROUGH, FT.
6	245	NO LIFT	1.0	2.0
12	540	NO LIFT	1.7	2.9
10	430	1210	1.6	2.4
19	710	1320	1.6	2.5
24	750	1510	1.3	2.2
29	870	1765	1.6	2.9

\*MEASURED WITH A WAVE BUOY AT A POINT 150 FT. NORMAL TO THE STRAIGHT PATH OF THE SES.

## SCALE WEIGHING

The SES was scale weighed with USN load cells at Halter Marine Inc. facilities in New Orleans, LA, two months following the conclusion of at-sea testing in the Norfolk area. The craft was lifted with the normal Halter Marine hoisting gear that is comprised of fore and aft 2-legged cable bridles attached to the ends of a ridged spreader structure that in turn has fore and aft cables that terminate at the single crane hook. Calibrated load cells were inserted in the aft bridle legs with compensating length links in the forward legs. A lift was made and a measurement of load recorded along with the hoisting gear geometry. The procedure was then repeated with the load cells exchanged with the compensating links. The resulting measurements were resolved into a total weight of the SES, as hoisted, of 261,400 pounds and a corresponding LCG location 15.41 feet forward of the aft hoisting points (46.41 feet forward of the transom, frame 15). This weight includes 38,200 pounds of liquids aboard during the weighing that was the sum of the following components: 3,100 lbs. of potable water; 12,400 lbs. of fuel; 11,000 lbs. of ballast water in tanks; 9,200 lbs. of bilge water in various compartments and sewage; and 2,500 lbs. of water in a flooded compartment over the starboard propeller. When weighed, the SES was outfitted the same as during the February - March 1980 trials with the following two exceptions: (1) less an inflatable boat with outboard motor, etc. (approximately 250 pounds); and (2) less U.S.N. test gear, instrumentation, and spares (approximately 1,500 pounds). The average trial displacement was 272,000 lbs.

## RELIABILITY, MAINTAINABILITY AND MAINTENANCE

During the 30-day test period in the Norfolk area an assessment was made of SES reliability and maintainability. Due to the short test time, a complete assessment could not be made but trends could be identified. Corrective and preventive maintenance data were collected along with all failure data. These results are reported in Appendix B. A block-time chart of a simulated ferry operation is included in Appendix B.

## VESSEL MANNING AND HUMAN FACTORS

A survey of the SES was conducted both in port with a cold plant and underway during the simulated ferry operation to determine manning requirements for a civilian passenger ferry and a Coast Guard patrol boat. Areas of the craft which should receive detailed human engineering design effort were identified. This evaluation was performed by the U.S.N. Personnel and Training Analysis Office (NAVSEA 05LIC). The PATAO report is included in this report as Appendix C.

## DISCUSSION

The evaluation of the qualities of any marine vehicle can be directed in many different directions and usually results in the comparison of one or more performance parameters with those of other craft of similar type and design. The Bell-Halter 110-foot SES, a large-displacement sidehull surface effect ship, is a unique type and design of operating craft and therefore performance comparisons within a family of similar craft is not possible. Several techniques have recently evolved that permit the comparison of basic performance parameters, in a normalized or non-dimensional sense, for marine vehicles of differing design types and differing size and displacement classes. The latter is important because of the scarcity of published quantitative test results for all types of craft. A presentation of comparative smooth water performance and load carrying capability of the SES is given in figures 41 and 42 utilizing a format and some of the results from reference 7. A comparison of SES ride quality with those of a diverse group of other vessels is presented in figure 43 in a format and with results from reference 8. The results in those figures are derived from actual trial measurements and are not theoretical or model predictions.

Comparative smooth water performance, figure 41, shows the non-dimensional speed-power results for the SES and 82-foot WPB compared with similar type results for 10 other craft ranging in size and type from a 25-foot surf rescue boat with a hybrid stepped hull and hydrofoil to a 165-foot patrol gunboat with a displacement hull. The format is a transportation efficiency coefficient versus speed coefficient (volume Froude number:  $F_V$ ) computed from displacement, speed, and power factors. The several lines in figure 41 labeled for different hull types and that together form an approximate diagonal on the figure, represent an indication of current state-of-the-art performance. The SES, especially when normally loaded (no. 1), is clearly "in advance" of the state-of-the-art in this comparison. The LCVP(K), no. 10, is included here because it was a prototype surface effect vessel (circa 1963) that had thin sidewalls, an articulated hinged flat bow seal to contain air ducted beneath the hull and was termed an "air lubricated hull." The other craft presented in figure 41 are generally open water patrol craft with top speeds that meet or exceed that of the SES.

Useful load as a percentage of design displacement (load fraction) is presented as a function of  $F_V$  for the SES in comparison with 10 other craft in figure 42. Results for some of the craft, like the SES, are presented for several different loads. The design condition (240,000 lbs.) for the SES was projected from the results of the heavier conditions that were tested. Useful load in this figure includes fuel, potable water, ship's complement and effects, stores, and military payload, if any. The SES compares less favorably as a load carrier than the several moderate deadrise planing hulls CPIC(X), 80 ft. PTF, LCSR(L) in a similar or higher speed range. These three craft each are equipped with high power-density, sophisticated propulsion systems. If the SES was similarly equipped, its relative position on this speed-load fraction comparison would be considerably improved. The comparative vessels in this figure range from the heavy displacement landing craft LCM-8 to the lightly loaded deep vee harbor security HSPB.

Ride quality in a marine vehicle is always a difficult parameter to quantify because so many factors such as vessel size, speed, weight, sea state, and motion interact to affect ride. The ride quality criteria presented in figure 43 is based on an assumption that has evolved from varied combatant craft experience that the upper limit of acceptable c.g. acceleration is an average of the 1/10 highest accelerations equal to 1 g. In figure 43, if a vessel's top speed in the seaway is less than its position on the plot with respect to the "design speed", the vessel under those conditions is within the criteria. For example, the SES operated approximately 26 knots in (head sea) sea state 4; the SES falls on the 30-knot "design speed" line; therefore the SES is within the criteria. The other craft shown are also within the criteria except the PTF OSPREY, a known "hard rider," and the LCVP(K). The LCVP(K), with a top speed in rough water in excess of 21 knots, is in excess of the criteria. The KNOX class FF-1052, a displacement ship, is included to demonstrate the extreme; it would react to a sea state 3 or 4 as a small craft would to a near calm. This criteria is based on accelerations only and does not allow for pitching and rolling motions per se. Therefore, the 82-foot WPB ranks well within the ride criteria which are not affected by the previously discussed large WPB roll motions. The displacement-sea state chart at the top of figure 43 gives the approximate sea state condition associated with the vessel points below. The SES, at 121-ton displacement, projected upward falls within the sea state 4 area; which, in fact, was the sea state measured during the trial condition represented. The LCVP(K), at 14-ton displacement, is in excess of the criteria in low sea state 2, and the 82-foot WPB would be expected to exceed the criteria in mid-sea state 3 at a speed of approximately 24 knots. The displacements of the other vessels plotted are tabulated on figure 41 except that for the FF-1052 which is approximately 4000 tons.

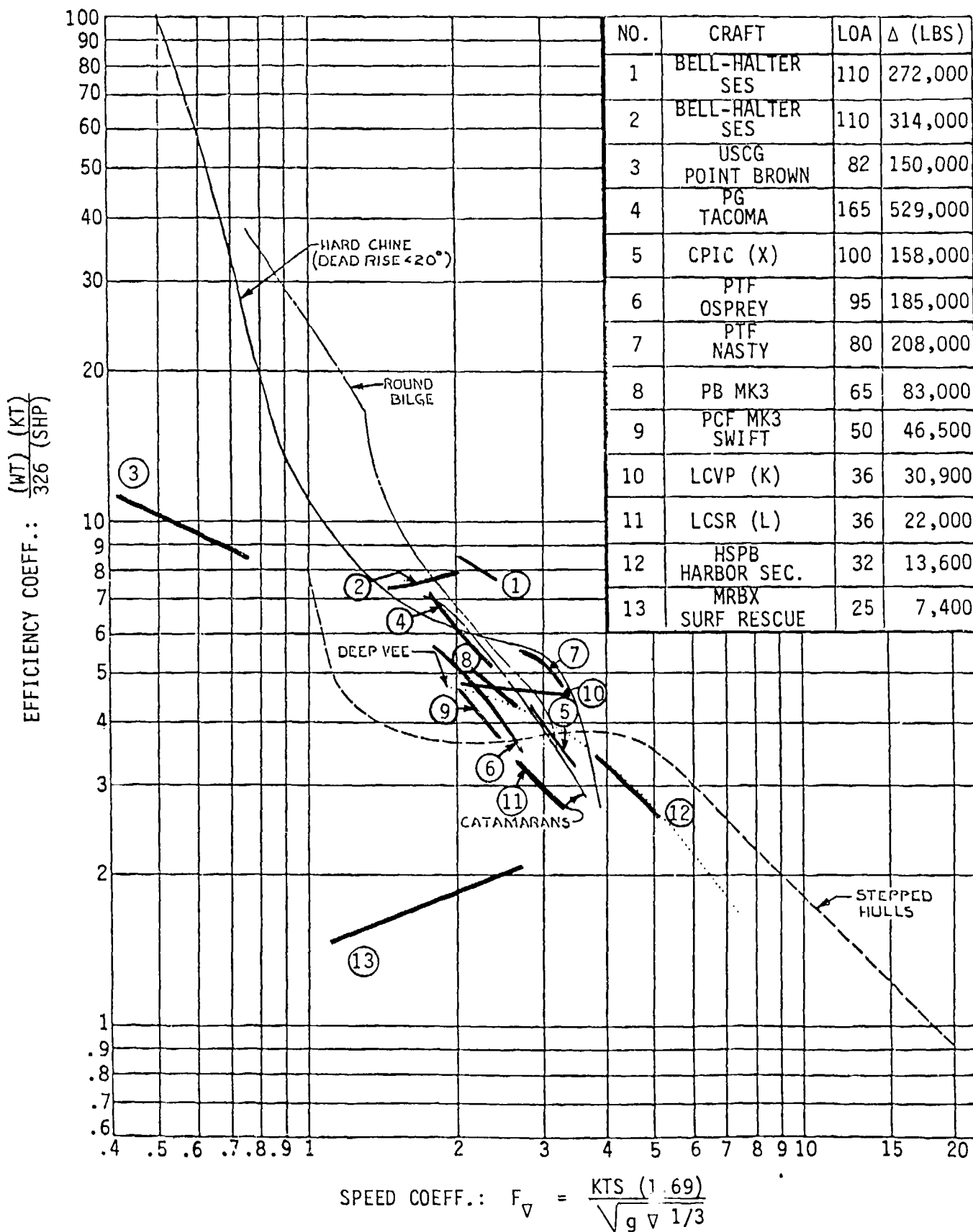

FIGURE 41. COMPARATIVE SMOOTH WATER PERFORMANCE

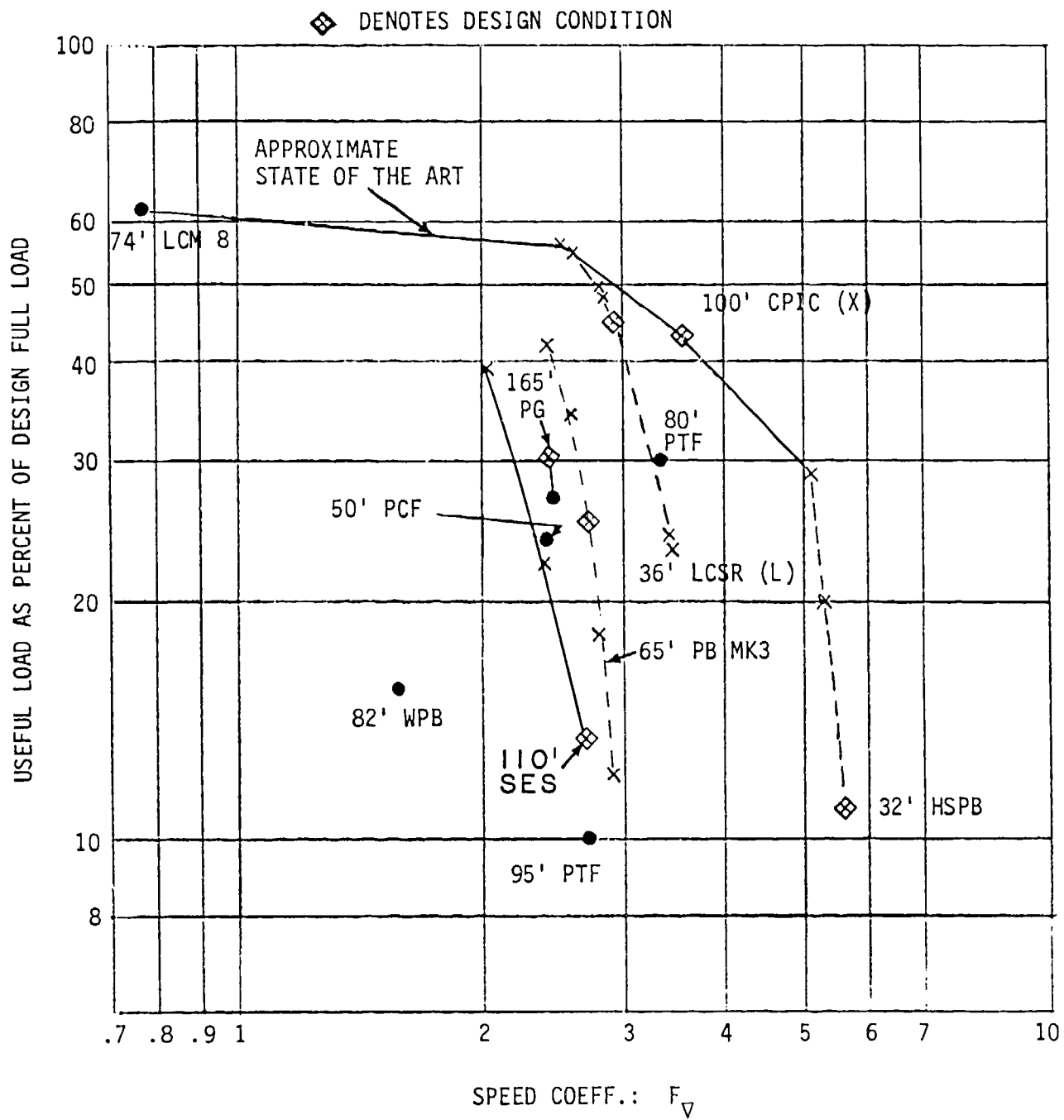
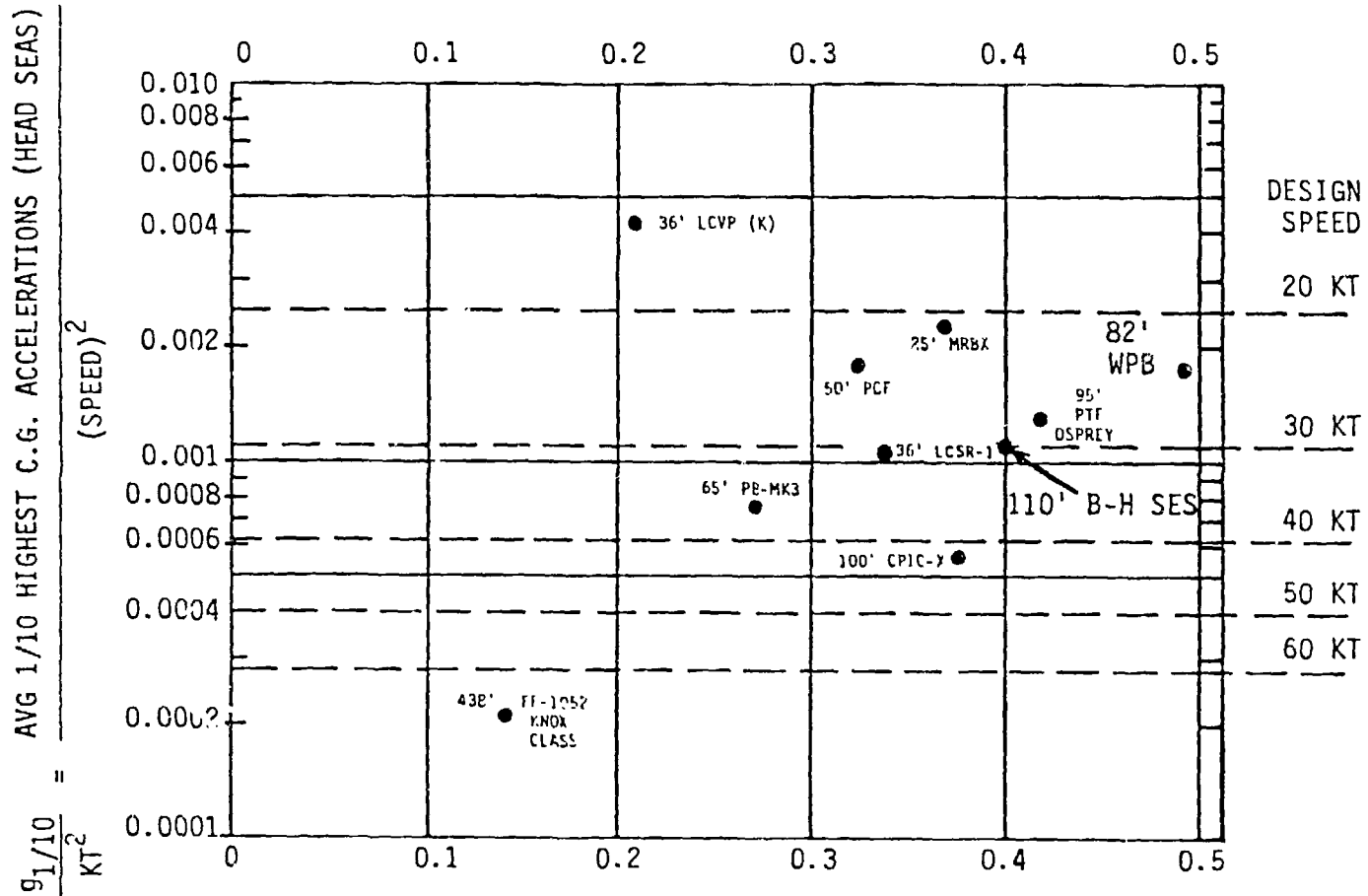

FIGURE 42. USEFUL LOAD FRACTION, STATE OF THE ART

DISPLACEMENT  
LONG TONS

1000	SS-1	SS-2	SS-3	SS-4	SS-5	SS-6
400	SS-1	SS-2	SS-3	SS-4	SS-5	
100	SS-1	SS-2	SS-3	SS-4		
10	SS-1		SS-2			SS-3
1		SS-1		SS-2		SS-3



$$\frac{H_{1/3}}{\sqrt[3]{V}} = \frac{\text{AVG 1/3 HIGHEST WAVE HTS}}{\sqrt[3]{\text{DISPLACED VOLUME}}}$$

FIGURE 43. RIDE QUALITY CRITERIA

## CONCLUSIONS

The test results indicate the Bell-Halter 110-foot SES is an effective and able marine vehicle that warrants consideration for varied future military and civilian applications.

## ACKNOWLEDGEMENTS

The accomplishment of a test program as varied and extensive as that performed with the Bell-Halter SES, and the WPB Point Brown, is of necessity the result of the dedicated effort of numerous organizations and individuals. For their contributions to this test program, particular acknowledgement should go to: Mr. J. W. Lewis (NAVSEADDET) who selected, calibrated, and operated the SES instrumentation suit; Messrs. A. A. Miller, C. E. Shields, M. P. Jones, and J. L. Morris of NAVSEADDET who operated instrumentation and recorded data; LT Gibson and the crew of the USCG Cutter Point Brown; and CAPT Firmin and Messrs R. Blackburn, T. Wexler, and P. Holland of the Bell-Halter SES crew.

## LIST OF REFERENCES

1. Kelly, J. J., "The Advanced Patrol Boat - Its Technology and Applications", Bell-Halter - New Orleans, 1978
2. Kelly, J. J., "The SES as an Offshore Boat", Bell-Halter - New Orleans, 18 November 1978
3. U.S.C.G. Military Interdepartmental Purchase Request (MIPR) Z70099-0-00953 "SES TEST PLAN DEVELOPMENT" of 31 Oct 1979
4. Naval Ship Engineering Center, Norfolk, Va., "Surface Effect Ship Test Plan for BELL-HALTER 110-Foot Demonstration Craft", 15 January 1980
5. Naval Ship Engineering Center, Norfolk Division ltr 6663/PKS, 9583, Ser 228 of 3 APR 1980
6. OSHA (1970), "Part 1910-Occupational Safety, and Health Standards", (P.L. 91-596) (84 Stat. 1593, 1600; 29 U.S.C. 655, 657) Federal Register Vol. 36, No. 105, May 29, 1971
7. Gore, J. L. (editor), "Advanced Naval Vehicles Concepts Evaluation Planing Vehicle Technical Assessment (U)," DTNSRDC Rpt, SDD-114-24, August 1976, CONFIDENTIAL
8. Savitsky, D., and Numata, E., "Comparative Impact Accelerations of Various High Speed Planing Craft (U)," Stevens Institute of Technology Rpt, SIT-DL-77-1951, March 1977, CONFIDENTIAL

APPENDIX A  
SEAWORTHINESS TEST RESULTS FOR THE BELL-HALTER  
110-FOOT SES AND 82-FOOT WPB IN  
SEA STATES 2 TO 4

## APPENDIX A

### Seaworthiness Test Results for the Bell-Halter 110-Foot SES and 82-Foot WPB in Sea States 2 to 4

The following pages present more comprehensive seaworthiness test results than those presented in the main report. The data is presented in order of ascending sea states and grouped by test dates. Where applicable, SES and WPB data is arranged for easy comparison. Data is presented for 52 runs of the SES with 30 of the runs side-by-side with the WPB.

The aforementioned statistical results are repeated along with a listing of mean value, number of peaks, and root mean square (rms) value for each parameter during each trial run. The rms values present a measure of relative energy content experienced during the run (and between various runs) among parameters of similar units (pitch and roll angles in degrees, accelerations in g's). A chronological listing of each peak and each trough, for each parameter, is included (starting from the beginning of each run up to a maximum of the first 16 data points) that gives a sense of the sequential occurrence of events during the run. A ranked listing of peaks and troughs is also presented for each parameter starting with the largest magnitude measured during the run and progressing down through a maximum number of 16 data points.

SEAWORTHINESS TEST RESULTS IN SEA STATE 2 (29 FEB 1980)

229S01

RUN 1 HEAD SEA, SES, 0 KNOTS - D I W

	AVERAGE		AVE 1/3		AVE 1/10		EXTREME	
	PK	TR	PK	TR	PK	TR	PK	TR
PITCH	1.85	-1.80	2.81	-2.68	3.39	-3.18	3.84	-3.68
ROLL	0.72	-0.87	0.95	-1.14	1.16	-1.35	1.37	-1.56
VRWAC	0.15	-0.06	0.20	-0.11	0.23	-0.14	0.26	-0.21
VSTRNA	0.12	-0.06	0.15	-0.10	0.17	-0.12	0.22	-0.15
UCGAC	0.00	-0.00	0.00	-0.00	0.00	-0.00	0.00	-0.00
TRCGAC	0.01	-0.05	0.07	-0.06	0.06	-0.07	0.09	-0.08

CHRONOLOGICAL OUTPUT*		2 16	
PITCH	3.61	3.86	2.41
ROLL	-3.03	-3.68	-2.51
PITCH	2.12	2.64	1.55
ROLL	-1.58	-2.44	-1.84

CHRONOLOGICAL OUTPUT*		3 16	
ROLL	0.73	0.59	0.78
ROLL	-0.73	-0.93	-0.68
ROLL	0.78	0.49	0.54
ROLL	-1.22	-0.73	-0.68

CHRONOLOGICAL OUTPUT*		4 16	
VRWAC	0.18	0.26	0.20
VRWAC	0.03	-0.13	-0.15
VRWAC	0.18	0.15	0.10
VRWAC	0.08	-0.10	0.00

CHRONOLOGICAL OUTPUT*		5 16	
VSTRNA	0.16	0.16	0.11
VSTRNA	-0.10	-0.13	-0.06
VSTRNA	0.10	0.10	0.14
VSTRNA	-0.06	-0.03	-0.08

CHRONOLOGICAL OUTPUT*		7 16	
TRCGAC	-0.00	0.00	0.00
TRCGAC	-0.05	-0.05	-0.05
TRCGAC	0.01	0.01	0.03
TRCGAC	-0.04	-0.06	-0.05

RANKED OUTPUT*		2 16	
PITCH	3.86	3.78	3.61
PITCH	-3.68	-3.32	-3.30
PITCH	3.12	3.08	3.08
PITCH	-2.99	-2.98	-2.96

RANKED OUTPUT*		3 16	
ROLL	1.37	1.27	1.22
ROLL	-1.56	-1.51	-1.37
ROLL	1.03	0.93	0.93
ROLL	-1.17	-1.12	-1.12

RANKED OUTPUT*		4 16	
VRWAC	0.26	0.26	0.24
VRWAC	-0.21	-0.16	-0.15
VRWAC	0.23	0.23	0.21
VRWAC	-0.13	-0.13	-0.13

RANKED OUTPUT*		5 16	
VSTRNA	0.22	0.20	0.18
VSTRNA	-0.15	-0.13	-0.13
VSTRNA	0.16	0.16	0.15
VSTRNA	-0.11	-0.11	-0.11

RANKED OUTPUT*		7 16	
TRCGAC	0.09	0.05	0.03
TRCGAC	-0.08	-0.07	-0.06
TRCGAC	0.02	0.01	0.01
TRCGAC	-0.06	-0.06	-0.06

MEAN VALUE	NO. OF PEAKS	RMS
WAVEHT	0	0.00
PITCH	113	1.37
ROLL	81	0.47
VRWAC	125	0.07
VSTRNA	100	0.05
UCGAC	-1	0.01
TRCGAC	37	0.01
LMCGAC	0	0.00

SEAWORTHINESS TEST RESULTS IN SEA STATE 2 (29 FEB 1980)

RUN 2 S. BOW SEA, SES, 0 KNOTS - D I W

229S02

	CHRONOLOGICAL OUTPUT			AVERAGE			AVE 1/3			AVE 1/10			EXTREME		
	MEAN VALUE	NO. OF PEAKS	RMS	PK	TR		PK	TR		PK	TR	PK	TR	PK	TR
CHRONOLOGICAL OUTPUT 2 16															
PITCH	2.05	0.65	1.63	1.09	0.78	1.19	1.24	1.11	2.16	-2.10	2.67	2.68	3.04	-3.06	3.06
ROLL	-2.90	-1.66	-1.17	-0.73	-1.06	-1.19	-1.14	1.94	-1.91	3.05	-3.09	-4.02	5.22	-5.08	5.22
VRWAC	0.13	0.04	0.17	-0.07	0.20	-0.09	0.11	0.13	-0.04	0.13	-0.07	0.15	0.17	-0.10	0.17
USTRNA	0.11	-0.04	0.13	-0.07	0.15	-0.09	0.11	0.10	-0.00	0.11	-0.01	0.11	0.11	-0.02	0.11
VEGAC	0.10	-0.00	0.11	-0.01	0.11	-0.01	0.11	0.03	-0.08	0.05	-0.11	-0.14	0.10	-0.18	0.10
TRCGAC	0.03	-0.08	0.05	-0.11	0.07	-0.11	0.07	0.07	0.07	0.07	0.07	0.07	0.10	-0.18	0.10
RANKED OUTPUT 2 16															
PITCH	3.04	2.90	2.77	2.69	2.64	2.60	2.60	2.56	3.06	-2.90	-2.83	-2.77	-2.72	-2.62	-2.57
ROLL	-3.06	-2.90	-2.83	-2.77	-2.72	-2.62	-2.57	2.56	-2.46	-2.41	-2.29	-2.26	-2.21	-2.16	-2.12
VRWAC	2.56	2.54	2.47	2.33	2.28	2.26	2.18	2.18	3.66	3.61	3.37	3.32	3.27	3.22	3.17
USTRNA	3.61	3.52	3.42	3.37	3.22	3.17	3.12	3.12	5.22	4.93	4.54	4.20	4.05	3.86	3.71
VEGAC	4.93	4.64	4.49	4.30	4.20	4.15	4.05	4.05	5.08	4.64	4.49	4.30	4.20	4.15	4.05
TRCGAC	3.66	3.61	3.37	3.32	3.27	3.22	3.17	3.17	3.81	3.52	3.42	3.37	3.22	3.17	3.12
RANKED OUTPUT 3 16															
ROLL	5.22	4.93	4.54	4.20	4.05	3.86	3.71	3.71	5.08	4.64	4.49	4.30	4.20	4.15	4.05
VRWAC	4.93	4.64	4.49	4.30	4.20	4.15	4.05	4.05	3.66	3.61	3.37	3.32	3.27	3.22	3.17
USTRNA	3.66	3.61	3.37	3.32	3.27	3.22	3.17	3.17	5.22	4.93	4.54	4.20	4.05	3.86	3.71
VEGAC	4.93	4.64	4.49	4.30	4.20	4.15	4.05	4.05	5.08	4.64	4.49	4.30	4.20	4.15	4.05
TRCGAC	3.66	3.61	3.37	3.32	3.27	3.22	3.17	3.17	3.81	3.52	3.42	3.37	3.22	3.17	3.12
RANKED OUTPUT 4 16															
ROLL	5.22	4.93	4.54	4.20	4.05	3.86	3.71	3.71	5.08	4.64	4.49	4.30	4.20	4.15	4.05
VRWAC	4.93	4.64	4.49	4.30	4.20	4.15	4.05	4.05	3.66	3.61	3.37	3.32	3.27	3.22	3.17
USTRNA	3.66	3.61	3.37	3.32	3.27	3.22	3.17	3.17	5.22	4.93	4.54	4.20	4.05	3.86	3.71
VEGAC	4.93	4.64	4.49	4.30	4.20	4.15	4.05	4.05	5.08	4.64	4.49	4.30	4.20	4.15	4.05
TRCGAC	3.66	3.61	3.37	3.32	3.27	3.22	3.17	3.17	3.81	3.52	3.42	3.37	3.22	3.17	3.12
RANKED OUTPUT 5 16															
ROLL	5.22	4.93	4.54	4.20	4.05	3.86	3.71	3.71	5.08	4.64	4.49	4.30	4.20	4.15	4.05
VRWAC	4.93	4.64	4.49	4.30	4.20	4.15	4.05	4.05	3.66	3.61	3.37	3.32	3.27	3.22	3.17
USTRNA	3.66	3.61	3.37	3.32	3.27	3.22	3.17	3.17	5.22	4.93	4.54	4.20	4.05	3.86	3.71
VEGAC	4.93	4.64	4.49	4.30	4.20	4.15	4.05	4.05	5.08	4.64	4.49	4.30	4.20	4.15	4.05
TRCGAC	3.66	3.61	3.37	3.32	3.27	3.22	3.17	3.17	3.81	3.52	3.42	3.37	3.22	3.17	3.12
RANKED OUTPUT 6 16															
ROLL	5.22	4.93	4.54	4.20	4.05	3.86	3.71	3.71	5.08	4.64	4.49	4.30	4.20	4.15	4.05
VRWAC	4.93	4.64	4.49	4.30	4.20	4.15	4.05	4.05	3.66	3.61	3.37	3.32	3.27	3.22	3.17
USTRNA	3.66	3.61	3.37	3.32	3.27	3.22	3.17	3.17	5.22	4.93	4.54	4.20	4.05	3.86	3.71
VEGAC	4.93	4.64	4.49	4.30	4.20	4.15	4.05	4.05	5.08	4.64	4.49	4.30	4.20	4.15	4.05
TRCGAC	3.66	3.61	3.37	3.32	3.27	3.22	3.17	3.17	3.81	3.52	3.42	3.37	3.22	3.17	3.12
RANKED OUTPUT 7 16															
ROLL	5.22	4.93	4.54	4.20	4.05	3.86	3.71	3.71	5.08	4.64	4.49	4.30	4.20	4.15	4.05
VRWAC	4.93	4.64	4.49	4.30	4.20	4.15	4.05	4.05	3.66	3.61	3.37	3.32	3.27	3.22	3.17
USTRNA	3.66	3.61	3.37	3.32	3.27	3.22	3.17	3.17	5.22	4.93	4.54	4.20	4.05	3.86	3.71
VEGAC	4.93	4.64	4.49	4.30	4.20	4.15	4.05	4.05	5.08	4.64	4.49	4.30	4.20	4.15	4.05
TRCGAC	3.66	3.61	3.37	3.32	3.27	3.22	3.17	3.17	3.81	3.52	3.42	3.37	3.22	3.17	3.12
RANKED OUTPUT 8 16															
ROLL	5.22	4.93	4.54	4.20	4.05	3.86	3.71	3.71	5.08	4.64	4.49	4.30	4.20	4.15	4.05
VRWAC	4.93	4.64	4.49	4.30	4.20	4.15	4.05	4.05	3.66	3.61	3.37	3.32	3.27	3.22	3.17
USTRNA	3.66	3.61	3.37	3.32	3.27	3.22	3.17	3.17	5.22	4.93	4.54	4.20	4.05	3.86	3.71
VEGAC	4.93	4.64	4.49	4.30	4.20	4.15	4.05	4.05	5.08	4.64	4.49	4.30	4.20	4.15	4.05
TRCGAC	3.66	3.61	3.37	3.32	3.27	3.22	3.17	3.17	3.81	3.52	3.42	3.37	3.22	3.17	3.12
RANKED OUTPUT 9 16															
ROLL	5.22	4.93	4.54	4.20	4.05	3.86	3.71	3.71	5.08	4.64	4.49	4.30	4.20	4.15	4.05
VRWAC	4.93	4.64	4.49	4.30	4.20	4.15	4.05	4.05	3.66	3.61	3.37	3.32	3.27	3.22	3.17
USTRNA	3.66	3.61	3.37	3.32	3.27	3.22	3.17	3.17	5.22	4.93	4.54	4.20	4.05	3.86	3.71
VEGAC	4.93	4.64	4.49	4.30	4.20	4.15	4.05	4.05	5.08	4.64	4.49	4.30	4.20	4.15	4.05
TRCGAC	3.66	3.61	3.37	3.32	3.27	3.22	3.17	3.17	3.81	3.52	3.42	3.37	3.22	3.17	3.12
RANKED OUTPUT 10 16															
ROLL	5.22	4.93	4.54	4.20	4.05	3.86	3.71	3.71	5.08	4.64	4.49	4.30	4.20	4.15	4.05
VRWAC	4.93	4.64	4.49	4.30	4.20	4.15	4.05	4.05	3.66	3.61	3.37	3.32	3.27	3.22	3.17
USTRNA	3.66	3.61	3.37	3.32	3.27	3.22	3.17	3.17	5.22	4.93	4.54	4.20	4.05	3.86	3.71
VEGAC	4.93	4.64	4.49	4.30	4.20	4.15	4.05	4.05	5.08	4.64	4.49	4.30	4.20	4.15	4.05
TRCGAC	3.66	3.61	3.37	3.32	3.27	3.22	3.17	3.17	3.81	3.52	3.42	3.37	3.22	3.17	3.12
RANKED OUTPUT 11 16															
ROLL	5.22	4.93	4.54	4.20	4.05	3.86	3.71	3.71	5.08	4.64	4.49	4.30	4.20	4.15	4.05
VRWAC	4.93	4.64	4.49	4.30	4.20	4.15	4.05	4.05	3.66	3.61	3.37	3.32	3.27	3.22	3.17
USTRNA	3.66	3.61	3.37	3.32	3.27	3.22	3.17	3.17	5.22	4.93	4.54	4.20	4.05	3.86	3.71
VEGAC	4.93	4.64	4.49	4.30	4.20	4.15	4.05	4.05	5.08	4.64	4.49	4.30	4.20	4.15	4.05
TRCGAC	3.66	3.61	3.37	3.32	3.27	3.22	3.17	3.17	3.81	3.52	3.42	3.37	3.22	3.17	3.12
RANKED OUTPUT 12 16															
ROLL	5.22	4.93	4.54	4.20	4.05	3.86	3.71	3.71	5.08	4.64	4.49	4.30	4.20	4.15	4.05
VRWAC	4.93	4.64	4.49	4.30	4.20	4.15	4.05	4.05	3.66	3.61	3.37	3.32	3.27	3.22	3.17
USTRNA	3.66	3.61	3.37	3.32	3.27	3.22	3.17	3.17	5.22	4.93	4.54	4.20	4.05	3.86	3.71
VEGAC	4.93	4.64	4.49	4.30	4.20	4.15	4.05	4.05	5.08	4.64	4.49	4.30	4.20	4.15	4.05
TRCGAC	3.66	3.61	3.37	3.32	3.27	3.22	3.17	3.17	3.81	3.52	3.42	3.37	3.22	3.17	3.12
RANKED OUTPUT 13 16															
ROLL	5.22	4.93	4.54	4.20	4.05	3.86	3.71	3.71	5.08	4.64	4.49	4.30	4.20	4.15	4.05
VRWAC	4.93	4.64	4.49	4.30	4.20	4.15	4.05	4.05	3.66	3.61	3.37	3.32	3.27	3.22	3.17
USTRNA	3.66	3.61	3.37	3.32	3.27	3.22	3.17	3.17	5.22	4.93	4.54	4.20	4.05	3.86	3.71
VEGAC	4.93	4.64	4.49	4.30	4.20	4.15	4.05	4.05	5.08	4.64	4.49	4.30	4.20	4.15	4.05
TRCGAC	3.66	3.61	3.37	3.32	3.27	3.22	3.17	3.17	3.81	3.52	3.42	3.37	3.22	3.17	3.12
RANKED OUTPUT 14 16															
ROLL	5.22	4.93	4.54	4.20	4.05	3.86	3.71	3.71	5.08	4.64	4.49	4.30	4.20	4.15	4.05
VRWAC	4.93	4.64	4.49	4.30	4.20	4.15	4.05	4.05	3.66	3.61	3.37	3.32	3.27	3.22	3.17
USTRNA	3.66	3.61	3.37	3.32	3.27	3.22	3.17	3.17	5.22	4.93	4.54	4.20	4.05	3.86	3.71
VEGAC	4.93	4													

SEAWORTHINESS TEST RESULTS IN SEA STATE 2 (29 FEB 1980)

RUN 3 S. BEAM SEA, SES, 0 KNOTS - D I W

229S03

CHRONOLOGICAL OUTPUT? 2 16

PITCH 0.70 0.93 0.55 0.67 0.99 0.57 0.85 0.93  
 -0.99 -1.16 -0.75 -0.63 -0.50 -1.07 -0.91 -1.04  
 PITCH 0.73 0.75 0.83 0.85 0.50 1.09 1.68 0.88  
 -0.83 -0.91 -0.93 -0.90 -0.73 -0.81 -1.01 -1.61

CHRONOLOGICAL OUTPUT? 3 16

ROLL 4.35 4.74 6.69 6.49 1.46 2.34 6.59 7.28  
 -2.39 -4.15 -5.03 -6.49 -4.00 -0.05 -3.71 -6.98  
 ROLL 5.76 2.10 1.61 0.98 4.10 2.15 2.64 2.93  
 -6.20 -3.76 -1.03 -0.88 -2.25 -3.47 -1.76 -2.69

CHRONOLOGICAL OUTPUT? 4 16

VBOWAC 0.16 0.16 0.10 0.11 0.11 0.18 0.15 0.15  
 -0.03 -0.08 -0.02 -0.05 0.00 -0.07 -0.07 -0.05  
 VBOWAC 0.11 0.11 0.10 0.10 0.15 0.11 0.15 0.11  
 -0.05 -0.03 0.00 0.00 -0.05 -0.03 -0.03 -0.07

CHRONOLOGICAL OUTPUT? 5 16

VSTRNA 0.10 0.10 0.11 0.10 0.09 0.10 0.11 0.08  
 -0.04 -0.05 -0.03 -0.05 -0.03 -0.04 -0.06 -0.05  
 VSTRNA 0.08 0.11 0.13 0.07 0.11 0.11 0.12 0.08  
 -0.02 -0.02 -0.07 -0.05 -0.03 -0.02 -0.05 -0.03

CHRONOLOGICAL OUTPUT? 6 16

VCBAC 0.12 0.11 0.11 0.11 0.10 0.12 0.10 0.10  
 -0.03 -0.02 -0.03 -0.03 0.00 0.00 -0.03 -0.01  
 VCBAC 0.10 0.10 0.10 0.10 0.09 0.10 0.10 0.10  
 -0.01 0.00 -0.01 -0.01 -0.01 -0.01 -0.02 -0.02

CHRONOLOGICAL OUTPUT? 7 16

TRCGAC 0.08 0.08 0.12 0.12 0.04 0.02 0.12 0.11  
 -0.10 -0.10 -0.18 -0.20 -0.13 -0.06 -0.11 -0.21  
 TRCGAC 0.11 0.06 0.04 0.04 0.09 0.04 0.00 0.03  
 -0.18 -0.14 -0.10 -0.09 -0.12 -0.12 -0.05 -0.08

MEAN VALUE	NO. OF PEAKS	RMS
MAVENT	0	0.00
PITCH	90	0.53
ROLL	130	2.55
VBOWAC	114	0.05
VSTRNA	70	0.03
VCBAC	37	0.03
TRCGAC	138	0.06
LMCGAC	0	0.00

AVERAGE			AVE 1/3			AVE 1/10			EXTREME			
PK	TR	TR	PK	TR	TR	PK	TR	TR	PK	TR	PK	TR
PITCH	0.85	-0.86	1.16	-1.18	1.41	1.41	-1.43	1.68	1.68	-1.99	1.68	-1.99
ROLL	3.43	-3.17	5.42	-5.00	6.72	6.72	-6.19	8.64	8.64	-7.57	8.64	-7.57
VBOWAC	0.13	-0.03	0.16	-0.07	0.18	0.18	-0.08	0.23	0.23	-0.13	0.23	-0.13
VSTRNA	0.10	-0.04	0.11	-0.05	0.12	0.12	-0.07	0.13	0.13	-0.07	0.13	-0.07
VCBAC	0.10	-0.02	0.11	-0.03	0.12	0.12	-0.04	0.12	0.12	-0.05	0.12	-0.05
TRCGAC	0.05	-0.11	0.09	-0.15	0.11	0.11	-0.19	0.14	0.14	-0.21	0.14	-0.21

RANKED OUTPUT? 2 16

PITCH 1.68 1.63 1.60 1.40 1.40 1.27 1.25 1.25  
 -1.99 -1.61 -1.38 -1.38 -1.33 -1.30 -1.29 -1.29  
 PITCH 1.24 1.24 1.22 1.17 1.14 1.09 1.07 1.07  
 -1.27 -1.25 -1.22 -1.17 -1.17 -1.16 -1.14 -1.12

RANKED OUTPUT? 3 16

ROLL 8.64 7.28 6.93 6.88 6.69 6.59 6.49 6.45  
 -7.57 -6.98 -6.69 -6.49 -6.35 -6.20 -6.20 -5.86  
 ROLL 6.45 6.35 6.35 6.25 6.01 5.91 5.76 5.66  
 -5.81 -5.57 -5.57 -5.52 -5.52 -5.47 -5.47 -5.42

RANKED OUTPUT? 4 16

VBOWAC 0.23 0.21 0.20 0.18 0.18 0.18 0.18 0.18  
 -0.13 -0.10 -0.08 -0.08 -0.08 -0.08 -0.08 -0.08  
 VBOWAC 0.16 0.16 0.16 0.16 0.16 0.16 0.15 0.15  
 -0.08 -0.07 -0.07 -0.07 -0.07 -0.07 -0.07 -0.07

RANKED OUTPUT? 5 16

VSTRNA 0.13 0.13 0.12 0.12 0.12 0.12 0.12 0.12  
 -0.07 -0.07 -0.07 -0.07 -0.07 -0.07 -0.07 -0.07  
 VSTRNA 0.12 0.11 0.11 0.11 0.11 0.11 0.11 0.11  
 -0.06 -0.05 -0.05 -0.05 -0.05 -0.05 -0.05 -0.05

RANKED OUTPUT? 6 16

VCBAC 0.12 0.12 0.12 0.11 0.11 0.11 0.11 0.11  
 -0.05 -0.03 -0.03 -0.03 -0.03 -0.03 -0.03 -0.03  
 VCBAC 0.11 0.11 0.11 0.11 0.11 0.11 0.10 0.10  
 -0.02 -0.02 -0.02 -0.02 -0.02 -0.02 -0.02 -0.02

RANKED OUTPUT? 7 16

TRCGAC 0.14 0.12 0.12 0.12 0.12 0.11 0.11 0.11  
 -0.21 -0.21 -0.20 -0.20 -0.20 -0.18 -0.18 -0.18  
 TRCGAC 0.10 0.10 0.10 0.10 0.10 0.10 0.10 0.10  
 -0.18 -0.18 -0.18 -0.17 -0.17 -0.17 -0.17 -0.17

SEAWORTHINESS TEST RESULTS IN SEA STATE 2 (29 FEB 1980)

RUN 4 S. QUARTERING SEA, SES, 0 KNOTS - D I W

229S04

	AVERAGE		AVE 1/3		AVE 1/10		EXTREME
	PK	TR	PK	TR	PK	TR	
PITCH	1.26	-1.22	1.88	-1.79	2.129	-2.19	2.57
ROLL	1.58	-1.37	2.51	-2.27	3.19	-2.88	4.00
VBOWAC	0.13	-0.03	0.18	-0.07	0.22	-0.10	0.28
VSTRNA	0.10	-0.05	0.13	-0.09	0.16	-0.11	0.20
VCGAC	0.11	-0.01	0.13	-0.03	0.15	-0.04	0.15
TRCGAC	0.02	-0.07	0.04	-0.09	0.05	-0.11	0.07

	RANKED OUTPUT		2 16	
PITCH	2.57	2.56	2.51	2.23
ROLL	-2.60	-2.36	-2.18	-2.12
PITCH	2.15	2.15	2.12	2.08
ROLL	-2.00	-1.99	-1.92	-1.89

	RANKED OUTPUT		3 16	
ROLL	4.00	3.56	3.37	3.32
ROLL	-3.27	-3.17	-3.08	-2.98
ROLL	2.92	2.88	2.83	2.78
ROLL	-2.78	-2.59	-2.54	-2.44

	RANKED OUTPUT		4 16	
VBOWAC	0.28	0.28	0.28	0.24
VBOWAC	-0.13	-0.13	-0.11	-0.10
VBOWAC	0.20	0.20	0.20	0.20
VBOWAC	-0.10	-0.08	-0.08	-0.08

	RANKED OUTPUT		5 16	
VSTRNA	0.20	0.19	0.17	0.16
VSTRNA	-0.13	-0.12	-0.11	-0.11
VSTRNA	0.15	0.15	0.15	0.14
VSTRNA	-0.10	-0.10	-0.10	-0.10

	RANKED OUTPUT		6 16	
VCGAC	0.15	0.15	0.13	0.13
VCGAC	-0.05	-0.04	-0.02	-0.02
VCGAC	0.11	0.11	0.11	0.11
VCGAC	-0.02	-0.02	-0.02	-0.02

	RANKED OUTPUT		7 16	
TRCGAC	0.07	0.06	0.06	0.05
TRCGAC	-0.12	-0.11	-0.11	-0.10
TRCGAC	0.05	0.05	0.04	0.04
TRCGAC	-0.10	-0.10	-0.10	-0.09

	CHRONOLOGICAL OUTPUT		2 16	
PITCH	1.35	1.73	0.72	0.57
PITCH	-0.65	-1.43	-1.58	-0.96
PITCH	0.67	0.75	1.14	1.38
PITCH	-1.22	-0.54	-0.83	-1.29

	CHRONOLOGICAL OUTPUT		3 16	
ROLL	1.42	1.07	2.93	1.76
ROLL	-1.03	-1.51	-1.90	-2.54
ROLL	2.29	1.51	1.46	1.95
ROLL	-1.71	-1.81	-1.17	-1.42

	CHRONOLOGICAL OUTPUT		4 16	
VBOWAC	0.11	0.16	0.10	0.13
VBOWAC	-0.03	-0.05	-0.03	-0.02
VBOWAC	0.10	0.13	0.15	0.13
VBOWAC	-0.02	-0.02	-0.05	-0.02

	CHRONOLOGICAL OUTPUT		5 16	
VSTRNA	0.10	0.11	0.07	0.08
VSTRNA	-0.02	-0.03	-0.05	-0.03
VSTRNA	0.08	0.13	0.08	0.10
VSTRNA	-0.02	-0.03	-0.07	-0.06

	CHRONOLOGICAL OUTPUT		6 16	
VCGAC	0.09	0.09	0.12	0.11
VCGAC	-0.05	-0.04	-0.02	-0.00
VCGAC	0.11	0.10	0.13	0.10
VCGAC	0.00	0.00	0.00	-0.02

	CHRONOLOGICAL OUTPUT		7 16	
TRCGAC	0.00	0.03	0.02	0.03
TRCGAC	-0.06	-0.08	-0.07	-0.07
TRCGAC	0.05	0.04	0.01	0.01
TRCGAC	-0.10	-0.11	-0.06	-0.05

	MEAN VALUE	NO. OF PEAKS	RMS
WAVEHT	-0.01	0	0.00
PITCH	0.01	105	0.89
ROLL	0.12	174	1.13
VBOWAC	0.04	177	0.05
VSTRNA	0.03	171	0.04
VCGAC	0.04	29	0.02
TRCGAC	-0.02	94	0.03
LWCGAC	-0.04	0	0.00



SEAWORTHINESS TEST RESULTS IN SEA STATE 2 (29 FEB 1980)

229S06

RUN 6 HEAD SEA, SES, APPROX. 29 KNOTS

	AVERAGE		AVE 1/3		AVE 1/10		EXTREME	
	PK	TR	PK	TR	PK	TR	PK	TR
CHRONOLOGICAL OUTPUT? 2 16								
PITCH	0.60	0.15	0.37	0.50	0.72	0.67	0.39	0.62
ROLL	-0.81	-0.94	-1.51	-0.76	-0.56	-0.99	-2.03	-0.63
PITCH	0.65	0.68	0.57	0.44	0.37	0.33	1.46	1.43
ROLL	-0.73	-1.77	-0.96	-0.88	-0.73	-0.78	-1.63	-1.60
CHRONOLOGICAL OUTPUT? 3 1								
PITCH	0.49	0.68	0.78	0.78	0.93	1.12	0.83	0.98
ROLL	-0.49	-0.73	-0.54	-0.34	-0.73	-0.54	-0.49	-0.39
PITCH	0.44	0.29	2.10	1.61	1.32	1.17	0.59	0.34
ROLL	-0.68	-0.73	-0.78	-0.39	0.29	-0.63	-0.93	-1.17
CHRONOLOGICAL OUTPUT? 4 16								
PITCH	0.31	0.39	0.76	0.39	0.39	0.36	0.49	0.46
ROLL	-0.28	-0.41	-0.46	-0.34	-0.33	-0.31	-0.34	-0.28
PITCH	0.62	0.55	0.39	0.96	0.65	0.50	0.57	0.46
ROLL	-0.31	-0.29	-0.28	-0.47	-0.41	-0.34	-0.34	-0.28
CHRONOLOGICAL OUTPUT? 5 16								
PITCH	0.28	0.46	0.49	0.25	0.34	0.32	0.67	0.35
ROLL	-0.33	-0.33	-0.20	-0.31	-0.26	-0.20	-0.31	-0.33
PITCH	0.31	0.31	0.20	0.27	0.33	0.31	0.32	0.43
ROLL	-0.19	-0.35	-0.32	-0.39	-0.25	-0.30	-0.26	-0.20
CHRONOLOGICAL OUTPUT? 6 16								
PITCH	0.29	0.34	0.63	0.40	0.37	0.28	0.47	0.40
ROLL	-0.31	-0.26	-0.27	-0.33	-0.21	-0.24	-0.25	-0.20
PITCH	0.43	0.32	0.86	0.38	0.55	0.29	0.31	0.39
ROLL	-0.25	-0.23	-0.42	-0.38	-0.24	-0.27	-0.38	-0.23
CHRONOLOGICAL OUTPUT? 7 16								
PITCH	0.05	0.03	0.04	0.04	0.03	0.04	0.03	0.02
ROLL	-0.06	-0.07	-0.07	-0.09	-0.07	-0.07	-0.07	-0.08
PITCH	0.03	0.02	0.10	0.10	0.09	0.08	0.08	0.08
ROLL	-0.07	-0.07	-0.08	-0.17	-0.17	-0.17	-0.16	-0.16
MEAN VALUE NO. OF PEAKS RMS								
WAVEHT	-0.02	0	0.00					
PITCH	-0.01	13	0.33					
ROLL	0.03	25	0.41					
VROMAC	0.04	399	0.25					
VSTRNA	0.03	187	0.15					
UCGAC	0.04	266	0.18					
TRCGAC	-0.02	9	0.02					
LNCGAC	-0.06	0	0.00					

SEAWORTHINESS TEST RESULTS IN SEA STATE 2 (29 FEB 1980)

229S07

RUN 7 FOLLOWING SEA, SES, APPROX. 29 KNOTS

	CHRONOLOGICAL OUTPUT?		2 16		AVERAGE		AVE 1/3		AVE 1/10		EXTREME	
	PK	TR	PK	TR	PK	TR	PK	TR	PK	TR	PK	TR
PITCH	1.07	0.93	0.67	0.91	1.35	1.29	0.96	0.94	1.70	-1.84	2.13	-2.26
ROLL	-0.76	-1.06	-1.46	-0.78	-1.45	-0.91	-1.16	-1.11	1.84	-2.12	2.15	-2.54
VRMAG	0.35	0.25	0.30	0.30	0.30	0.30	0.30	0.30	0.50	-0.35	0.52	-0.37
VSTRNA	0.33	0.25	0.38	0.30	0.38	0.30	0.36	0.36	0.42	-0.36	0.46	-0.39
VCGAC	0.36	0.21	0.40	0.26	0.40	0.26	0.44	0.28	0.44	-0.28	0.47	-0.32
TRCGAC	0.08	-0.06	0.12	-0.09	0.12	-0.09	0.15	-0.10	0.15	-0.10	0.19	-0.13

RANKED OUTPUT? 2 16

PITCH	2.13	1.99	1.81	1.69	1.66	1.63	1.60	1.55
ROLL	-2.26	-1.99	-1.77	-1.97	-1.89	-1.71	-1.66	-1.66

PITCH 1.51 1.43 1.42 1.42 1.42 1.42 1.38 1.35

ROLL	-1.64	-1.61	-1.61	-1.56	-1.55	-1.53	-1.51
------	-------	-------	-------	-------	-------	-------	-------

RANKED OUTPUT? 3 16

PITCH	2.15	2.10	1.81	1.76	1.66	1.56	1.51	1.51
ROLL	-2.54	-2.34	-2.05	-2.00	-1.90	-1.71	-1.56	-1.56

PITCH 1.46 1.37 1.32 1.32 1.32 1.27 1.27 1.22

ROLL	-1.56	-1.46	-1.42	-1.37	-1.32	-1.32	-1.27	-1.27
------	-------	-------	-------	-------	-------	-------	-------	-------

RANKED OUTPUT? 4 16

VRMAG	0.52	0.50	0.50	0.50	0.49	0.49	0.49	0.47
VSTRNA	0.47	0.47	0.47	0.44	0.42	0.42	0.42	0.41

VRMAG 0.31 0.29 0.29 0.29 0.29 0.29 0.29 0.29

VSTRNA	0.31	0.31	0.31	0.31	0.31	0.31	0.31	0.31
--------	------	------	------	------	------	------	------	------

RANKED OUTPUT? 5 16

VSTRNA	0.46	0.42	0.38	0.38	0.37	0.37	0.37	0.36
VCGAC	0.39	0.35	0.34	0.31	0.30	0.29	0.29	0.28

VSTRNA 0.35 0.35 0.34 0.34 0.34 0.33 0.33 0.33

VCGAC	0.27	0.26	0.26	0.26	0.26	0.26	0.26	0.25
-------	------	------	------	------	------	------	------	------

RANKED OUTPUT? 6 16

VCGAC	0.47	0.40	0.39	0.39	0.39	0.39	0.39	0.38
TRCGAC	0.32	0.25	0.25	0.24	0.24	0.24	0.24	0.24

VCGAC 0.38 0.37 0.37 0.37 0.37 0.36 0.36 0.34

TRCGAC	0.22	0.21	0.21	0.21	0.20	0.20	0.20	0.19
--------	------	------	------	------	------	------	------	------

RANKED OUTPUT? 7 16

TRCGAC	0.19	0.17	0.16	0.13	0.13	0.12	0.12	0.12
VCGAC	0.13	0.11	0.10	0.10	0.09	0.09	0.09	0.09

TRCGAC 0.12 0.12 0.12 0.11 0.11 0.11 0.10 0.10

VCGAC	0.09	0.09	0.08	0.08	0.08	0.08	0.08	0.08
-------	------	------	------	------	------	------	------	------

	MEAN VALUE	NO. OF PEAKS	RMS
WAVENT	-0.02	0	0.00
PITCH	-0.01	106	0.69
ROLL	-0.09	67	0.66
VRMAG	0.04	83	0.12
VSTRNA	0.03	38	0.09
VCGAC	0.04	22	0.09
TRCGAC	-0.02	74	0.02
LRCGAC	-0.05	0	0.00

SEAWORTHINESS TEST RESULTS IN SEA STATE 2 (29 FEB 1980)

229S08

RUN 8 S. BEAM SEA, SES, APPROX. 29 KNOTS

CHRONOLOGICAL OUTPUT?		2 16		AVERAGE		AVE 1/3		AVE 1/10		EXTREME	
		PK	TR	PK	TR	PK	TR	PK	TR	PK	TR
PITCH	0.80 0.70 1.17 0.52 0.55 0.46 0.96 1.27	0.67	-0.60	0.91	-0.80	1.22	-0.93	1.27	-0.94	1.27	-0.94
	-0.36 -0.31 -0.46 -0.72 -0.54 -0.94 -0.55 -0.63	2.01	-1.91	3.47	-3.39	4.54	-4.38	5.91	-4.93	5.91	-4.93
PITCH	0.65 0.68 0.59 0.50 0.80 0.54 0.65 0.68	0.33	0.26	0.41	-0.33	0.48	-0.41	0.59	-0.50	0.59	-0.50
	-0.70 -0.54 -0.49 -0.57 -0.57 -0.85 -0.46 -0.39	0.32	-0.24	0.39	-0.27	0.42	-0.28	0.42	-0.28	0.42	-0.28
		0.33	-0.23	0.37	-0.29	0.40	-0.33	0.40	-0.33	0.40	-0.33
		0.05	-0.11	0.09	-0.13	0.14	-0.14	0.14	-0.14	0.19	-0.16
RANKED OUTPUT? 2 16											
PITCH	1.27 1.17 0.96 0.85 0.81 0.80 0.80 0.78	1.27	1.17	0.96	-0.85	0.81	0.80	0.80	0.80	0.80	0.78
	-0.94 -0.91 -0.90 -0.85 -0.78 -0.73 -0.72 -0.70	-0.94	-0.91	-0.90	-0.85	-0.78	-0.73	-0.72	-0.72	-0.72	-0.70
PITCH	0.73 0.72 0.70 0.68 0.68 0.68 0.67 0.65	0.73	0.72	0.70	0.68	0.68	0.68	0.67	0.67	0.67	0.65
	-0.70 -0.67 -0.65 -0.65 -0.63 -0.57 -0.57 -0.55	-0.70	-0.67	-0.65	-0.65	-0.63	-0.57	-0.57	-0.57	-0.57	-0.55
RANKED OUTPUT? 3 16											
ROLL	5.91 4.83 4.79 4.74 4.54 4.35 4.35 4.05	5.91	4.83	4.79	4.74	4.54	4.35	4.35	4.35	4.35	4.05
	-4.93 -4.79 -4.69 -4.64 -4.59 -4.35 -4.20 -3.96	-4.93	-4.79	-4.69	-4.64	-4.59	-4.35	-4.20	-4.20	-4.20	-3.96
ROLL	4.00 3.86 3.76 3.71 3.61 3.61 3.52 3.52	4.00	3.86	3.76	3.71	3.61	3.61	3.52	3.52	3.52	3.52
	-3.86 -3.86 -3.71 -3.66 -3.61 -3.61 -3.52 -3.47	-3.86	-3.86	-3.71	-3.66	-3.61	-3.61	-3.52	-3.52	-3.52	-3.47
RANKED OUTPUT? 4 16											
VBOWAC	0.59 0.52 0.44 0.42 0.41 0.41 0.41 0.41	0.59	0.52	0.44	0.42	0.41	0.41	0.41	0.41	0.41	0.41
	-0.50 -0.47 -0.37 -0.36 -0.34 -0.33 -0.33 -0.33	-0.50	-0.47	-0.37	-0.36	-0.34	-0.33	-0.33	-0.33	-0.33	-0.33
VBOWAC	0.39 0.39 0.39 0.39 0.39 0.39 0.37 0.34	0.39	0.39	0.39	0.39	0.39	0.37	0.37	0.37	0.37	0.34
	-0.31 -0.31 -0.29 -0.28 -0.28 -0.28 -0.28 -0.28	-0.31	-0.31	-0.29	-0.28	-0.28	-0.28	-0.28	-0.28	-0.28	-0.28
RANKED OUTPUT? 5 16											
VSTRNA	0.42 0.41 0.41 0.41 0.41 0.37 0.36 0.33	0.42	0.41	0.41	0.41	0.41	0.37	0.36	0.36	0.33	0.32
	-0.28 -0.28 -0.27 -0.26 -0.26 -0.25 -0.25 -0.24	-0.28	-0.28	-0.27	-0.26	-0.26	-0.25	-0.25	-0.25	-0.25	-0.24
VSTRNA	0.31 0.31 0.31 0.29 0.29 0.29 0.29 0.28	0.31	0.31	0.31	0.29	0.29	0.29	0.29	0.29	0.28	0.28
	-0.24 -0.24 -0.24 -0.24 -0.24 -0.24 -0.24 -0.22	-0.24	-0.24	-0.24	-0.24	-0.24	-0.24	-0.24	-0.24	-0.23	-0.22
RANKED OUTPUT? 6 16											
VCGAC	0.40 0.37 0.37 0.36 0.35 0.35 0.34 0.33	0.40	0.37	0.37	0.36	0.35	0.35	0.35	0.35	0.34	0.33
	-0.33 -0.29 -0.29 -0.26 -0.24 -0.24 -0.22 -0.22	-0.33	-0.29	-0.29	-0.26	-0.24	-0.24	-0.22	-0.22	-0.22	-0.22
VCGAC	0.31 0.30 0.29 0.28 0.28 0.28 0.28 0.28	0.31	0.30	0.29	0.28	0.28	0.28	0.28	0.28	0.28	0.28
	-0.21 -0.20 -0.20 -0.18 -0.17 -0.17 -0.15 -0.19	-0.21	-0.20	-0.20	-0.18	-0.17	-0.15	-0.20	-0.20	-0.20	-0.19
RANKED OUTPUT? 7 16											
TRCGAC	0.19 0.15 0.15 0.15 0.13 0.13 0.12 0.11	0.19	0.15	0.15	0.15	0.13	0.13	0.12	0.12	0.11	0.10
	-0.16 -0.15 -0.15 -0.14 -0.14 -0.14 -0.13 -0.13	-0.16	-0.15	-0.15	-0.14	-0.14	-0.14	-0.13	-0.13	-0.13	-0.13
TRCGAC	0.10 0.09 0.09 0.08 0.08 0.08 0.08 0.08	0.10	0.09	0.09	0.08	0.08	0.08	0.08	0.08	0.08	0.08
	-0.13 -0.13 -0.13 -0.13 -0.13 -0.13 -0.13 -0.13	-0.13	-0.13	-0.13	-0.13	-0.13	-0.13	-0.13	-0.13	-0.13	-0.13

SEAWORTHINESS TEST RESULTS IN SEA STATE 2 (29 FEB 1980)

RUN 9 P. QUARTERING SEA, SES, APPROX. 31 KNOTS

229S09

CHRONOLOGICAL OUTPUT?	2 16		AVERAGE		AVE 1/3		AVE 1/10		EXTREME	
	PK	TR	PK	TR	PK	TR	PK	TR	PK	TR
PITCH	0.57	0.75	0.46	0.46	0.29	0.70	0.42	0.24	-0.44	-0.57
ROLL	-0.44	-0.57	-0.55	-0.90	-1.29	-0.86	-1.16	-0.80	1.32	1.32
VBOWAC	0.34	0.34	-0.24	0.40	-0.28	0.49	-0.34	0.49	0.34	0.34
VSTRNA	0.61	1.04	0.62	1.01	0.55	0.63	0.62	0.72	0.31	0.31
VCGAC	-0.91	-0.70	-0.85	-1.09	-0.93	-0.54	-0.68	-0.72	0.33	0.33
TRCGAC	0.07	-0.08	0.12	-0.08	0.12	-0.11	-0.14	-0.19	0.07	0.07

CHRONOLOGICAL OUTPUT?	3 16		RANKED OUTPUT?	
	PK	TR	PK	TR
ROLL	1.07	3.27	1.76	1.76
ROLL	-1.71	-1.90	0.39	0.24
ROLL	0.78	1.56	1.61	1.71
ROLL	-0.98	-1.61	-1.32	0.05

CHRONOLOGICAL OUTPUT?	4 16		RANKED OUTPUT?	
	PK	TR	PK	TR
VBOWAC	0.33	0.34	0.31	0.47
VBOWAC	-0.20	-0.20	-0.21	-0.23
VBOWAC	0.33	0.28	0.34	0.28
VBOWAC	-0.33	-0.23	-0.21	-0.26

CHRONOLOGICAL OUTPUT?	5 16		RANKED OUTPUT?	
	PK	TR	PK	TR
VSTRNA	0.24	0.28	0.32	0.37
VSTRNA	-0.26	-0.28	-0.30	-0.27
VSTRNA	0.28	0.25	0.25	0.44
VSTRNA	-0.21	-0.26	-0.28	-0.32

CHRONOLOGICAL OUTPUT?	6 5		RANKED OUTPUT?	
	PK	TR	PK	TR
VCGAC	0.37	0.33	0.37	0.31
VCGAC	-0.19	-0.20	-0.21	-0.22

CHRONOLOGICAL OUTPUT?	7 16		RANKED OUTPUT?	
	PK	TR	PK	TR
TRCGAC	0.10	0.13	0.09	0.12
TRCGAC	-0.06	-0.09	-0.09	-0.09
TRCGAC	0.06	0.07	0.08	0.05
TRCGAC	-0.08	-0.08	-0.06	-0.06

MEAN VALUE	NO. OF PEAKS	RMS	RANKED OUTPUT?	
			PK	TR
WAVEHT	0	0.00		
PITCH	42	0.39	0.19	0.17
ROLL	91	1.16	-0.17	-0.15
VBOWAC	37	0.10	0.13	0.13
VSTRNA	19	0.09	-0.12	-0.12
VCGAC	5	0.07	0.28	0.28
TRCGAC	136	0.04	-0.23	-0.22
LNCGAC	0	0.00		



SEAWORTHINESS TEST RESULTS IN SEA STATE 2 (29 FEB 1980)

RUN 11 HEAD SEA, SES, APPROX. 10 KNOTS

229511

CHRONOLOGICAL OUTPUT? 2 16

PITCH 1.03 1.46 0.68 0.78 0.68 0.54 0.62 0.68  
 -0.98 -1.43 -1.12 -0.52 -0.44 -1.04 -1.04 -0.98  
 PITCH 0.49 0.59 0.83 1.12 0.55 0.24 0.63 0.50  
 -0.63 -0.98 -0.59 -1.56 -1.55 -0.99 -0.94 -0.70

CHRONOLOGICAL OUTPUT? 3 16

ROLL 0.49 0.59 0.44 0.49 0.54 0.78 0.59 0.59  
 -0.49 -0.49 -0.73 -0.54 -0.49 -0.44 -0.54 -0.39  
 ROLL 0.63 0.59 0.68 0.59 0.59 0.59 0.49 0.73  
 -0.73 -0.49 -0.73 -0.39 -0.44 -0.63 -0.49 -0.68

CHRONOLOGICAL OUTPUT? 4 16

VBOMAC 0.31 0.33 0.75 0.28 0.18 0.16 0.16 0.16  
 -0.16 -0.16 -0.26 -0.28 -0.07 -0.08 -0.13 -0.10  
 VBOMAC 0.21 0.20 0.15 0.36 0.21 0.41 0.10 0.94  
 -0.10 -0.10 -0.13 -0.13 -0.18 -0.08 -0.16 -0.23

CHRONOLOGICAL OUTPUT? 5 16

VSTRNA 0.27 0.34 0.23 0.18 0.26 0.28 0.58 0.15  
 -0.06 -0.11 -0.36 -0.07 -0.07 -0.08 -0.16 -0.30  
 VSTRNA 0.16 0.28 0.42 0.28 0.28 0.36 0.15 0.17  
 -0.22 -0.10 -0.05 -0.36 -0.18 -0.13 -0.16 -0.12

CHRONOLOGICAL OUTPUT? 6 16

VCGAC 0.20 0.23 0.39 0.23 0.27 0.27 0.18 0.26  
 -0.19 -0.06 -0.07 -0.15 -0.15 -0.11 -0.07 -0.08  
 VCGAC 0.25 0.24 0.19 0.32 0.23 0.20 0.24 0.28  
 -0.12 -0.07 -0.07 -0.06 -0.14 -0.11 -0.07 -0.11

CHRONOLOGICAL OUTPUT? 7 16

TRCGAC -0.00 -0.00 0.00 0.00 0.00 0.00 -0.01 0.00  
 -0.06 -0.05 -0.07 -0.05 -0.05 -0.06 -0.06 -0.06  
 TRCGAC -0.00 -0.01 0.01 0.00 0.01 0.00 0.01 -0.00  
 -0.06 -0.06 -0.06 -0.07 -0.06 -0.06 -0.07 -0.06

	MEAN VALUE	NO. OF PEAKS	RMS
WAUERT	-0.01	0	0.00
PITCH	-0.01	77	0.41
ROLL	0.02	31	0.25
VBOMAC	0.05	246	0.11
VSTRNA	0.04	127	0.07
VCGAC	0.05	36	0.04
TRCGAC	-0.03	32	0.01
LMCGAC	-0.03	0	0.00

AVERAGE TR AVE 1/3 TR AVE 1/10 TR EXTREME TR  
 PK TR PK TR PK TR PK TR PK TR  
 PITCH 0.68 -0.83 0.93 -1.13 1.14 -1.42 1.46 -1.56  
 ROLL 0.57 -0.55 0.66 -0.67 0.75 -0.73 0.78 -0.73  
 VBOMAC 0.29 -0.14 0.46 -0.21 0.69 -0.25 1.14 -0.41  
 VSTRNA 0.27 -0.13 0.35 -0.23 0.44 -0.35 0.60 -0.55  
 VCGAC 0.24 -0.10 0.31 -0.14 0.39 -0.17 0.43 -0.19  
 TRCGAC -0.00 -0.06 0.01 -0.07 0.01 -0.07 0.01 -0.07

RANKED OUTPUT? 2 16

PITCH 1.46 1.22 1.12 1.12 1.09 1.03 0.96 0.93  
 -1.56 -1.55 -1.43 -1.38 -1.35 -1.30 -1.30 -1.27

PITCH 0.91 0.90 0.90 0.90 0.88 0.86 0.86 0.83  
 -1.12 -1.12 -1.09 -1.06 -1.04 -1.04 -1.04 -1.01

RANKED OUTPUT? 3 16

ROLL 0.78 0.73 0.73 0.68 0.68 0.63 0.63 0.59  
 -0.73 -0.73 -0.73 -0.68 -0.68 -0.68 -0.68 -0.63

ROLL 0.59 0.59 0.59 0.59 0.59 0.59 0.59 0.54  
 -0.59 -0.59 -0.59 -0.54 -0.54 -0.54 -0.54 -0.54

RANKED OUTPUT? 4 16

VBOMAC 1.14 0.99 0.98 0.94 0.83 0.75 0.75 0.74  
 -0.41 -0.37 -0.29 -0.28 -0.28 -0.26 -0.26 -0.26

VBOMAC 0.72 0.72 0.70 0.68 0.63 0.62 0.59 0.59  
 -0.26 -0.26 -0.24 -0.24 -0.23 -0.23 -0.23 -0.23

RANKED OUTPUT? 5 16

VSTRNA 0.60 0.58 0.48 0.46 0.43 0.42 0.42 0.42  
 -0.55 -0.43 -0.37 -0.36 -0.36 -0.33 -0.33 -0.32

VSTRNA 0.38 0.37 0.37 0.36 0.36 0.36 0.36 0.36  
 -0.30 -0.27 -0.27 -0.25 -0.24 -0.24 -0.23 -0.23

RANKED OUTPUT? 6 16

VCGAC 0.43 0.39 0.35 0.32 0.32 0.28 0.28 0.27  
 -0.19 -0.16 -0.15 -0.15 -0.15 -0.14 -0.13 -0.13

VCGAC 0.27 0.27 0.26 0.25 0.24 0.24 0.24 0.24  
 -0.13 -0.12 -0.12 -0.11 -0.11 -0.11 -0.11 -0.11

RANKED OUTPUT? 7 16

TRCGAC 0.01 0.01 0.01 0.01 0.00 0.00 0.00 0.00  
 -0.07 -0.07 -0.07 -0.07 -0.07 -0.07 -0.06 -0.06

TRCGAC 0.00 0.00 0.00 0.00 0.00 0.00 0.00 0.00  
 -0.06 -0.06 -0.06 -0.06 -0.06 -0.06 -0.06 -0.06

SEAWORTHINESS TEST RESULTS IN SEA STATE 2 (29 FEB 1980)

RUN11 HEAD SEA, WPB, APPROX. 10 KNOTS

229W11

	AVERAGE		AVE 1/3		AVE 1/10		EXTREME
	PK	TR	PK	TR	PK	TR	
FITCH	0.98	-1.11	1.91	-1.96	2.61	-2.45	3.42
ROLL	0.81	-0.78	1.47	-1.32	1.80	-1.67	2.10
VRWAC	0.28	-0.33	0.43	-0.54	0.54	-0.59	0.70
VRNA	0.14	-0.15	0.22	-0.23	0.27	-0.30	0.33
VRGAC	0.12	-0.11	0.17	-0.18	0.21	-0.24	0.26
TRGAC	0.05	-0.06	0.05	-0.06	0.06	-0.07	0.06

RANKED OUTPUT? 1 16

PITCH	3.42	2.95	2.93	2.85	2.82	2.77	2.73	2.69
	-2.98	-2.73	-2.70	-2.65	-2.64	-2.52	-2.46	-2.41
PITCH	2.49	2.46	2.43	2.29	2.28	2.28	2.25	2.18
	-2.33	-2.31	-2.28	-2.26	-2.25	-2.23	-2.21	-2.18

RANKED OUTPUT? 2 16

ROLL	2.10	2.00	1.90	1.76	1.71	1.71	1.61	1.61
	-2.05	-1.95	-1.81	-1.66	-1.56	-1.56	-1.42	-1.37
ROLL	1.56	1.56	1.51	1.51	1.46	1.46	1.42	1.42
	-1.27	-1.27	-1.27	-1.27	-1.27	-1.27	-1.27	-1.22

RANKED OUTPUT? 3 16

VRWAC	0.70	0.67	0.67	0.65	0.63	0.60	0.57	0.55
	-0.88	-0.81	-0.78	-0.78	-0.78	-0.76	-0.76	-0.75
VRWAC	0.54	0.54	0.52	0.50	0.50	0.50	0.50	0.49
	-0.75	-0.75	-0.73	-0.70	-0.67	-0.65	-0.63	-0.62

RANKED OUTPUT? 4 16

VRNA	0.33	0.31	0.31	0.29	0.29	0.28	0.28	0.28
	-0.41	-0.37	-0.36	-0.33	-0.33	-0.32	-0.32	-0.31
VRNA	0.26	0.28	0.28	0.28	0.26	0.25	0.25	0.25
	-0.30	-0.30	-0.30	-0.28	-0.28	-0.28	-0.28	-0.27

RANKED OUTPUT? 5 15

VCGAC	0.26	0.23	0.23	0.23	0.22	0.22	0.22	0.21
	-0.30	-0.29	-0.28	-0.28	-0.28	-0.27	-0.26	-0.26
VCGAC	0.21	0.20	0.20	0.20	0.20	0.20	0.20	0.19
	-0.25	-0.24	-0.23	-0.22	-0.22	-0.21	-0.20	-0.20

RANKED OUTPUT? 6 6

TRCGAC	0.06	0.05	0.05	0.05	0.04	0.04	0.04	0.04
	-0.07	-0.06	-0.06	-0.06	-0.06	-0.06	-0.06	-0.06

	CHRONOLOGICAL OUTPUT? 1 16		CHRONOLOGICAL OUTPUT? 2 16		CHRONOLOGICAL OUTPUT? 3 16		CHRONOLOGICAL OUTPUT? 4 16		CHRONOLOGICAL OUTPUT? 5 16		CHRONOLOGICAL OUTPUT? 6 6	
	MEAN VALUE	NO. OF PEAKS	MEAN VALUE	NO. OF PEAKS	MEAN VALUE	NO. OF PEAKS	MEAN VALUE	NO. OF PEAKS	MEAN VALUE	NO. OF PEAKS	MEAN VALUE	NO. OF PEAKS
FITCH	2.46	2.28	2.82	2.85	2.29	2.28	2.69	2.93	2.69	2.69	2.69	2.69
	0.62	0.73	0.62	0.10	0.46	1.12	0.60	-0.03	0.60	-0.03	0.60	-0.03
PITCH	2.95	3.42	2.00	2.49	2.77	2.10	1.76	2.43	2.43	2.43	2.43	2.43
	0.33	-0.99	-0.31	0.11	-0.29	-0.39	0.60	-0.03	0.60	-0.03	0.60	-0.03

CHRONOLOGICAL OUTPUT? 1 16

ROLL	-0.10	1.76	1.61	1.71	0.44	0.68	1.51	1.22	1.22	1.22	1.22	1.22
	-1.27	-1.12	0.63	0.54	-0.68	-0.59	-0.49	-1.07	-1.07	-1.07	-1.07	-1.07
ROLL	0.49	1.27	2.10	2.00	1.12	0.10	0.49	0.24	0.24	0.24	0.24	0.24
	-0.83	-0.59	-1.17	0.10	-0.34	-0.88	-0.98	-1.22	-1.22	-1.22	-1.22	-1.22

CHRONOLOGICAL OUTPUT? 3 16

VRWAC	0.36	0.26	0.20	0.42	0.50	0.36	0.16	0.26	0.26	0.26	0.26	0.26
	-0.50	-0.28	-0.23	-0.31	-0.59	-0.46	-0.33	-0.18	-0.18	-0.18	-0.18	-0.18
VRWAC	0.44	0.31	0.39	0.63	0.36	0.3	0.47	0.52	0.52	0.52	0.52	0.52
	-0.36	-0.52	-0.31	-0.81	-0.76	-0.23	-0.55	-0.63	-0.63	-0.63	-0.63	-0.63

CHRONOLOGICAL OUTPUT? 4 16

VRNA	0.15	0.10	0.10	0.21	0.25	0.17	0.08	0.11	0.11	0.11	0.11	0.11
	-0.15	-0.09	-0.07	-0.14	-0.23	-0.20	-0.07	-0.07	-0.07	-0.07	-0.07	-0.07
VRNA	0.23	0.15	0.28	0.29	0.09	0.19	0.22	0.23	0.23	0.23	0.23	0.23
	-0.15	-0.15	-0.15	-0.37	-0.30	-0.16	-0.27	-0.28	-0.28	-0.28	-0.28	-0.28

CHRONOLOGICAL OUTPUT? 5 16

VCGAC	0.15	0.11	0.10	0.16	0.20	0.15	0.08	0.11	0.11	0.11	0.11	0.11
	-0.15	-0.10	-0.07	-0.12	-0.20	-0.15	-0.08	-0.06	-0.06	-0.06	-0.06	-0.06
VCGAC	0.16	0.11	0.13	0.26	0.16	0.09	0.17	0.17	0.17	0.17	0.17	0.17
	-0.13	-0.15	-0.08	-0.29	-0.26	-0.07	-0.16	-0.21	-0.21	-0.21	-0.21	-0.21

CHRONOLOGICAL OUTPUT? 6 6

TRCGAC	0.04	0.05	0.04	0.05	0.06	0.06	0.05	0.05	0.05	0.05	0.05	0.05
	-0.06	-0.07	-0.06	-0.06	-0.06	-0.06	-0.06	-0.06	-0.06	-0.06	-0.06	-0.06

	MEAN VALUE	NO. OF PEAKS	RMS
FITCH	-0.00	169	1.00
ROLL	-0.02	87	0.66
VRWAC	0.01	234	0.23
VRNA	-0.00	217	0.11
VCGAC	0.01	204	0.08
TRCGAC	-0.00	6	0.02

SEAWORTHINESS TEST RESULTS IN SEA STATE 2 (29 FEB 1980)

229S12

RUN 12 FOLLOWING SEA, SES, APPROX. 10 KNOTS

	CHRONOLOGICAL OUTPUT <sup>†</sup>		2 10		AVERAGE		AVE 1/3		AVE 1/10		EXTREME	
	PITCH	ROLL	PK	TR	PK	TR	PK	TR	PK	TR	PK	TR
PITCH	0.62	0.44	0.70	0.90	0.93	0.98	0.62	0.65	0.98	0.98	0.98	-0.98
ROLL	-0.78	-0.55	-0.68	-0.39	-0.75	-0.98	-0.75	-0.70	-0.93	-0.93	0.68	-0.93
VROMAC	0.10	0.10	0.00	0.00	0.00	0.00	0.00	0.00	0.00	0.13	0.00	0.00
VSTRNA	0.00	0.00	0.00	0.00	0.00	0.00	0.00	0.00	0.00	0.00	0.00	0.00
UCGAC	0.00	0.00	0.00	0.00	0.00	0.00	0.00	0.00	0.00	0.00	0.00	0.00
TRCGAC	-0.73	-0.52	-0.68	-0.49	-0.75	-0.98	-0.70	-0.70	-0.93	-0.93	0.68	-0.93

	RANKED OUTPUT <sup>†</sup>		3 9		RANKED OUTPUT <sup>†</sup>		2 10	
	PITCH	ROLL	PK	TR	PK	TR	PK	TR
PITCH	0.68	0.54	0.59	0.59	0.49	0.49	0.54	0.54
ROLL	-0.49	-0.93	-0.68	-0.44	-0.54	-0.54	-0.49	-0.49
VROMAC	0.10	0.10	0.00	0.00	0.00	0.00	0.00	0.00
VSTRNA	0.00	0.00	0.00	0.00	0.00	0.00	0.00	0.00
UCGAC	0.00	0.00	0.00	0.00	0.00	0.00	0.00	0.00
TRCGAC	-0.44	0.59	-0.52	-0.39	-0.44	-0.44	-0.44	-0.44

	RANKED OUTPUT <sup>†</sup>		4 12		RANKED OUTPUT <sup>†</sup>		3 9	
	PITCH	ROLL	PK	TR	PK	TR	PK	TR
PITCH	0.10	0.11	0.13	0.10	0.13	0.10	0.10	0.10
ROLL	0.00	0.00	0.00	0.00	0.00	0.00	0.00	0.00
VROMAC	0.10	0.10	0.10	0.10	0.10	0.10	0.10	0.10
VSTRNA	0.00	0.00	0.00	0.00	0.00	0.00	0.00	0.00
UCGAC	0.00	0.00	0.00	0.00	0.00	0.00	0.00	0.00
TRCGAC	-0.06	-0.05	-0.06	-0.05	-0.06	-0.05	-0.06	-0.05

	RANKED OUTPUT <sup>†</sup>		7 2		RANKED OUTPUT <sup>†</sup>		4 12	
	PITCH	ROLL	PK	TR	PK	TR	PK	TR
PITCH	0.00	0.00	0.00	0.00	0.00	0.00	0.00	0.00
ROLL	0.00	0.00	0.00	0.00	0.00	0.00	0.00	0.00
VROMAC	0.10	0.10	0.10	0.10	0.10	0.10	0.10	0.10
VSTRNA	0.00	0.00	0.00	0.00	0.00	0.00	0.00	0.00
UCGAC	0.00	0.00	0.00	0.00	0.00	0.00	0.00	0.00
TRCGAC	-0.06	-0.05	-0.06	-0.05	-0.06	-0.05	-0.06	-0.05

	MEAN VALUE	NO. OF PEAKS	RMS
WAVEHT	-0.01	0	0.00
PITCH	-0.00	10	0.28
ROLL	0.01	9	0.21
VROMAC	0.05	12	0.02
VSTRNA	0.04	-1	0.01
UCGAC	0.05	-1	0.01
TRCGAC	-0.03	2	0.01
LMCGAC	-0.04	0	0.00

SEAWORTHINESS TEST RESULTS IN SEA STATE 2 (29 FEB 1980)

RUN 12 FOLLOWING SEA, WPB, APPROX. 10 KNOTS

229W12

CHRONOLOGICAL OUTPUT?		1 16		AVERAGE		AVE 1/3		AVE 1/10		EXTREME	
		PK	TR	PK	TR	PK	TR	PK	TR	PK	TR
CHRONOLOGICAL OUTPUT?		1 16		AVERAGE		AVE 1/3		AVE 1/10		EXTREME	
FITCH	2.16 2.08	1.86	1.66	1.55	1.61	1.37	1.48	2.12	-1.81	2.16	-1.84
ROLL	0.36 0.42	0.80	0.54	0.39	0.29	0.31	0.37	4.70	-4.07	6.10	-4.35
FITCH	1.89 1.17	0.85	0.78	0.80	0.90	0.41	0.24	0.08	-0.10	0.10	-0.13
ROLL	0.26 -0.24	-0.39	-0.50	-0.33	-0.26	-1.19	-1.07	0.03	-0.07	0.05	-0.09
VSTRNA								0.02	-0.04	0.03	-0.05
VCGAC								0.04	-0.04	0.05	-0.05
TRCGAC								0.07	-0.11	0.08	-0.14
CHRONOLOGICAL OUTPUT?		2 16		AVERAGE		AVE 1/3		AVE 1/10		EXTREME	
FITCH	2.49 3.17	6.10	0.34	-0.44	1.07	2.78	2.69	1.66	1.61	1.55	1.48
ROLL	-1.66 0.59	-4.25	-2.25	-3.22	-2.34	-0.98	-2.00	-1.11	-1.07	-0.50	-0.39
FITCH	3.08 2.29	0.00	-0.34	-0.24	0.24	5.62	0.34	0.80	0.78	0.44	0.41
ROLL	1.12 -2.29	-2.39	-4.35	-1.90	-2.59	-1.76	-2.34	0.29	0.31	0.36	0.37
VSTRNA								0.85	0.80	0.44	0.41
VCGAC								0.26	0.29	0.36	0.37
TRCGAC								0.08	0.31	0.36	0.37
CHRONOLOGICAL OUTPUT?		3 16		AVERAGE		AVE 1/3		AVE 1/10		EXTREME	
FITCH	0.05 0.03	0.03	0.05	0.03	0.05	0.05	0.02	4.30	3.91	3.61	3.52
ROLL	-0.05 -0.05	-0.07	-0.05	-0.07	-0.07	-0.08	-0.03	-4.00	-3.76	-3.32	-3.22
FITCH	0.00 0.02	0.02	0.02	0.08	0.05	0.00	0.00	3.17	3.08	2.98	2.78
ROLL	-0.07 -0.05	-0.05	-0.03	-0.10	-0.08	-0.07	-0.07	-2.49	-2.39	-2.39	-2.34
VSTRNA								0.08	0.08	0.08	0.08
VCGAC								0.08	0.08	0.08	0.08
TRCGAC								0.08	0.08	0.08	0.08
CHRONOLOGICAL OUTPUT?		4 16		AVERAGE		AVE 1/3		AVE 1/10		EXTREME	
FITCH	0.02 0.02	0.02	0.02	0.02	0.02	0.02	0.00	0.10	0.10	0.10	0.08
ROLL	-0.03 -0.04	-0.03	-0.07	-0.06	-0.06	-0.05	-0.06	-0.11	-0.11	-0.11	-0.11
FITCH	0.03 0.03	0.02	0.05	0.03	0.02	0.02	0.02	0.08	0.08	0.08	0.08
ROLL	-0.05 -0.06	-0.07	-0.07	-0.05	-0.05	-0.06	-0.03	-0.10	-0.10	-0.10	-0.10
VSTRNA								0.08	0.08	0.08	0.08
VCGAC								0.08	0.08	0.08	0.08
TRCGAC								0.08	0.08	0.08	0.08
CHRONOLOGICAL OUTPUT?		5 16		AVERAGE		AVE 1/3		AVE 1/10		EXTREME	
FITCH	0.03 0.03	0.04	0.03	0.03	0.02	0.04	0.03	0.03	0.03	0.03	0.03
ROLL	-0.02 -0.02	-0.02	-0.02	-0.02	-0.03	-0.04	-0.02	-0.07	-0.07	-0.07	-0.07
FITCH	0.04 0.04	0.04	0.03	0.03	0.03	0.02	0.04	0.02	0.02	0.02	0.02
ROLL	-0.02 -0.03	-0.02	-0.03	-0.02	-0.02	-0.02	-0.02	-0.07	-0.07	-0.07	-0.06
VSTRNA								0.02	0.02	0.02	0.02
VCGAC								0.02	0.02	0.02	0.02
TRCGAC								0.02	0.02	0.02	0.02
CHRONOLOGICAL OUTPUT?		6 16		AVERAGE		AVE 1/3		AVE 1/10		EXTREME	
FITCH	-0.02 0.08	0.05	0.05	0.01	0.03	0.04	0.04	0.05	0.04	0.04	0.04
ROLL	-0.08 -0.08	-0.14	-0.03	-0.05	-0.07	-0.08	-0.06	-0.04	-0.04	-0.04	-0.04
FITCH	0.06 0.04	0.03	0.07	0.05	0.02	0.04	0.02	0.04	0.04	0.04	0.04
ROLL	-0.03 -0.02	-0.12	-0.03	-0.08	-0.04	-0.05	-0.03	-0.03	-0.03	-0.03	-0.03
VSTRNA								0.04	0.04	0.04	0.04
VCGAC								0.04	0.04	0.04	0.04
TRCGAC								0.04	0.04	0.04	0.04
MEAN VALUE		NO. OF PEAKS		RMS							
FITCH	0.01	20	0.99								
ROLL	-0.01	60	1.73								
VSTRNA	-0.01	271	0.03								
VCGAC	-0.02	121	0.02								
TRCGAC	-0.01	91	0.01								



SEAWORTHINESS TEST RESULTS IN SEA STATE 2 (29 FEB 1980)

RUN 13 P.BEAM SEA, WPB, APPROX. 10 KNOTS

229W13

	CHRONOLOGICAL OUTPUT* 1 16		AVERAGE		AVE 1/3		AVE 1/10		EXTREME	
	PK	TR	PK	TR	PK	TR	PK	TR	PK	TR
PITCH	-1.14	-1.12	-1.09	-1.03	-1.11	-1.12	-1.12	-0.24	-0.42	-0.50
ROLL	-2.13	-2.46	-2.43	-2.38	-2.33	-2.31	-2.31	-3.19	-3.11	-3.11
PITCH	-0.72	-0.65	-0.99	-1.12	-0.96	-1.12	13.54	12.03	11.12	-0.24
ROLL	-2.16	-2.43	-2.99	-2.34	-2.56	-2.21	2.23	20.99	20.99	20.99
CHRONOLOGICAL OUTPUT* 2 16										
ROLL	-4.59	-4.39	-2.98	-4.25	-3.56	-2.83	-2.69	-2.69	-2.59	-2.59
PITCH	-5.57	-7.13	-7.67	-6.20	-6.25	-6.01	-4.69	-4.69	-4.69	-4.69
ROLL	-3.66	-2.73	-2.10	-2.15	-2.39	-1.61	-3.03	-3.03	-3.37	-3.37
PITCH	-5.08	-7.91	-6.30	-5.22	-4.30	-6.45	-7.57	-5.86	-5.86	-5.86
CHRONOLOGICAL OUTPUT* 3 16										
UPDRAC	0.10	0.05	0.13	0.10	0.05	0.07	0.13	0.13	0.00	0.00
DOWNDRAC	-0.18	0.00	-0.05	-0.15	-0.07	-0.03	-0.07	-0.05	-0.05	-0.05
UPDRAC	0.05	0.07	0.18	0.18	0.13	0.16	0.10	0.10	0.20	0.20
DOWNDRAC	-0.05	0.00	-0.15	-0.18	-0.13	-0.13	-0.15	-0.15	-0.13	-0.13
CHRONOLOGICAL OUTPUT* 4 16										
USTRNA	0.05	0.07	0.02	0.02	0.03	0.06	0.05	0.05	0.07	0.07
DOWNDRAC	-0.07	-0.10	-0.09	-0.07	-0.06	-0.08	-0.08	-0.07	-0.07	-0.07
USTRNA	0.05	0.02	0.09	0.04	0.05	0.10	0.07	0.07	0.07	0.07
DOWNDRAC	-0.10	-0.06	-0.07	-0.11	-0.07	-0.11	-0.09	-0.12	-0.12	-0.12
CHRONOLOGICAL OUTPUT* 5 16										
UCRAC	0.03	0.07	0.03	0.07	0.03	0.07	0.09	0.09	0.08	0.08
DOWNDRAC	-0.05	-0.02	-0.04	-0.02	-0.03	-0.06	-0.07	-0.06	-0.06	-0.06
UCGAC	0.07	0.07	0.10	0.07	0.10	0.11	0.09	0.09	0.11	0.11
DOWNDRAC	-0.08	-0.07	-0.07	-0.08	-0.09	-0.11	-0.08	-0.10	-0.10	-0.10
CHRONOLOGICAL OUTPUT* 6 16										
TRCGAC	0.07	0.08	0.07	0.07	0.07	0.03	0.03	0.03	0.07	0.07
DOWNDRAC	-0.01	-0.01	-0.04	-0.01	-0.03	-0.04	-0.06	-0.05	-0.05	-0.05
TRCGAC	0.05	0.07	0.12	0.01	0.08	0.07	0.05	0.05	0.03	0.03
DOWNDRAC	-0.03	-0.01	-0.04	-0.05	-0.05	-0.02	-0.09	-0.08	-0.08	-0.08
MEAN VALUE NO. OF PEAKS RMS										
PITCH	0.02	73	4.57							
ROLL	-0.01	107	10.56							
UPDRAC	0.01	217	0.07							
DOWNDRAC	-0.01	188	0.07							
UCRAC	0.00	183	0.06							
TRCGAC	0.00	125	0.06							

SEAWORTHINESS TEST RESULTS IN SEA STATE 2 (29 FEB 1980)

229S14

RUN 14 S. BOW SEA, SES, APPROX. 10 KNOTS

RANKED OUTPUT# 2 16

PITCH	1.33	1.16	1.12	1.07	1.01	0.99	0.98	0.93
	-1.61	-1.51	-1.33	-1.29	-1.25	-1.24	-1.16	-1.14
PITCH	0.91	0.91	0.90	0.86	0.86	0.83	0.83	0.83
	-1.12	-1.09	-1.07	-1.06	-1.03	-1.03	-0.94	-0.93

CHRONOLOGICAL OUTPUT# 2 16

PITCH	1.16	0.55	0.60	0.60	0.70	0.63	0.90	1.23
	-0.91	-0.81	-0.49	-0.93	-0.54	-0.67	-0.53	-1.24
PITCH	0.85	0.47	0.57	0.68	0.70	0.60	0.66	0.67
	-1.06	-1.61	-1.07	-1.14	-0.63	-0.57	-0.70	-0.50

RANKED OUTPUT# 3 16

ROLL	1.46	1.32	1.32	1.32	1.22	1.17	1.17	1.12
	-1.71	-1.66	-1.66	-1.56	-1.56	-1.46	-1.42	-1.42
ROLL	1.12	1.12	1.07	1.07	1.03	1.03	1.03	1.03
	-1.37	-1.37	-1.32	-1.32	-1.27	-1.27	-1.22	-1.22

CHRONOLOGICAL OUTPUT# 3 16

ROLL	0.73	0.73	0.73	0.49	0.63	0.24	0.54	0.63
	-0.92	-1.12	-1.03	-1.22	-1.07	-0.93	-0.83	-0.88
ROLL	0.68	0.24	0.63	0.24	0.78	1.03	0.54	0.78
	-1.27	-0.78	-0.98	-1.03	-0.83	-1.12	-1.07	-0.98

RANKED OUTPUT# 5 16

USTRNA	0.46	0.41	0.37	0.37	0.37	0.37	0.36	0.36
	-0.29	-0.26	-0.24	-0.24	-0.20	-0.20	-0.19	-0.19
USTRNA	0.5	0.34	0.33	0.33	0.33	0.32	0.32	0.31
	-0.18	-0.17	-0.17	-0.16	-0.16	-0.15	-0.14	-0.14

MEAN VALUE	NO. OF PEAKS	RMS
-0.00	0	0.00
0.00	65	0.42
-0.12	107	0.52
0.05	399	0.08
0.04	269	0.06
0.05	181	0.03
-0.03	101	0.02
-0.04	0	0.00

RANKED OUTPUT# 6 16

VEGAC	0.28	0.24	0.23	0.22	0.22	0.22	0.20	0.20
	-0.16	-0.15	-0.11	-0.10	-0.10	-0.09	-0.09	-0.08
VEGAC	0.20	0.20	0.19	0.19	0.19	0.18	0.18	0.18
	-0.08	-0.08	-0.07	-0.07	-0.07	-0.07	-0.07	-0.06

AVERAGE	AVE 1/3	AVE 1/10	EXTREME
PK	TR	PK	TR
0.71	-0.77	1.11	-1.37
0.67	-0.94	1.24	-1.52
0.16	-0.05	0.25	-0.14
0.16	-0.05	0.26	-0.11
0.12	-0.02	0.16	-0.05
0.00	-0.07	0.02	-0.08

RANKED OUTPUT# 7 16

TRCGAC	0.04	0.03	0.03	0.03	0.03	0.03	0.02	0.02
	-0.10	-0.10	-0.10	-0.10	-0.10	-0.09	-0.09	-0.09
TRCGAC	0.02	0.02	0.02	0.02	0.02	0.02	0.01	0.01
	-0.09	-0.09	-0.09	-0.08	-0.08	-0.08	-0.08	-0.08

RANKED OUTPUT# 4 16

UPOMAC	0.60	0.60	0.52	0.49	0.46	0.46	0.46	0.46
	-0.26	-0.23	-0.23	-0.23	-0.23	-0.23	-0.23	-0.21
UPOMAC	0.44	0.39	0.37	0.37	0.36	0.33	0.33	0.33
	-0.21	-0.21	-0.21	-0.21	-0.20	-0.20	-0.20	-0.20

SEAWORTHINESS TEST RESULTS IN SEA STATE 2 (29 FEB 1980)

229W14

RUN 14 S.BOW SEA, WPB, APPROX. 10 KNOTS

CHRONOLOGICAL OUTPUT?		1 16		AVERAGE		AVE 1/3		AVE 1/10		EXTREME	
		PK	TR	PK	TR	PK	TR	PK	TR	PK	TR
PITCH	1.32	1.71	1.84	1.42	1.58	1.43	1.71	1.51	1.71	1.51	1.84
ROLL	0.15	-0.03	-0.28	0.00	0.16	-0.10	0.07	-0.13	0.07	-0.13	0.07
PITCH		1.43	1.22	1.32	1.4	1.53	1.42	2.21	2.00	2.00	2.00
ROLL		0.42	-0.15	-0.05	0.24	-0.26	0.10	-0.52	-1.04	0.10	-0.52
CHRONOLOGICAL OUTPUT?		2 16		AVERAGE		AVE 1/3		AVE 1/10		EXTREME	
		PK	TR	PK	TR	PK	TR	PK	TR	PK	TR
PITCH	0.85	1.90	1.03	0.59	1.17	0.59	-0.20	0.44	1.84	1.74	1.74
ROLL	-2.39	-2.00	-1.12	-0.49	-0.73	-0.93	-1.27	-1.56	-1.99	-1.87	-1.86
PITCH		1.46	0.93	0.59	0.88	1.27	1.22	0.63	1.63	1.63	1.58
ROLL		-0.73	-1.51	-0.98	-1.12	-0.63	-0.44	-0.78	-1.74	-1.71	-1.64
CHRONOLOGICAL OUTPUT?		3 16		AVERAGE		AVE 1/3		AVE 1/10		EXTREME	
		PK	TR	PK	TR	PK	TR	PK	TR	PK	TR
PITCH	0.20	0.18	0.13	0.28	0.29	0.16	0.02	0.18	2.25	2.20	1.90
ROLL	-0.29	-0.28	-0.18	-0.31	-0.28	-0.37	-0.10	-0.15	-2.29	-2.15	-2.05
PITCH		0.13	0.16	0.23	0.28	0.31	0.15	0.18	1.61	1.56	1.51
ROLL		-0.29	-0.16	-0.20	-0.31	-0.37	-0.34	-0.26	-1.81	-1.66	-1.66
CHRONOLOGICAL OUTPUT?		4 16		AVERAGE		AVE 1/3		AVE 1/10		EXTREME	
		PK	TR	PK	TR	PK	TR	PK	TR	PK	TR
PITCH	0.15	0.08	0.09	0.15	0.16	0.07	0.10	0.06	0.78	0.46	0.44
ROLL	-0.12	-0.15	-0.06	-0.15	-0.16	-0.14	-0.07	-0.12	-0.59	-0.55	-0.52
PITCH		0.11	0.11	0.09	0.11	0.11	0.03	0.13	0.37	0.37	0.37
ROLL		-0.09	-0.08	-0.12	-0.16	-0.15	-0.0	-0.08	-0.46	-0.46	-0.44
CHRONOLOGICAL OUTPUT?		5 16		AVERAGE		AVE 1/3		AVE 1/10		EXTREME	
		PK	TR	PK	TR	PK	TR	PK	TR	PK	TR
PITCH	0.10	0.56	0.07	0.13	0.15	0.07	0.09	0.06	0.28	0.24	0.21
ROLL	-0.09	-0.07	-0.03	-0.10	-0.13	-0.11	-0.07	-0.08	-0.24	-0.24	-0.23
PITCH		0.07	0.11	0.15	0.12	0.14	0.07	0.10	0.19	0.19	0.19
ROLL		-0.02	-0.07	-0.11	-0.15	-0.13	-0.08	-0.07	-0.22	-0.21	-0.21
CHRONOLOGICAL OUTPUT?		6 16		AVERAGE		AVE 1/3		AVE 1/10		EXTREME	
		PK	TR	PK	TR	PK	TR	PK	TR	PK	TR
PITCH	0.09	0.04	0.02	0.04	0.03	0.05	0.04	0.06	0.30	0.20	0.19
ROLL	-0.08	-0.08	-0.04	-0.05	-0.05	-0.06	-0.02	-0.18	-0.20	-0.18	-0.16
PITCH		0.03	0.03	0.04	0.06	0.06	0.05	0.04	0.16	0.16	0.16
ROLL		-0.03	-0.04	-0.03	-0.07	-0.06	-0.03	-0.04	-0.15	-0.15	-0.15
CHRONOLOGICAL OUTPUT?		7 16		AVERAGE		AVE 1/3		AVE 1/10		EXTREME	
		PK	TR	PK	TR	PK	TR	PK	TR	PK	TR
PITCH	0.91	1.30	1.19	0.09	0.08	0.08	0.08	0.08	0.08	0.08	0.08
ROLL	-0.01	-0.02	0.98	-0.08	-0.08	-0.08	-0.08	-0.08	-0.08	-0.08	-0.08
PITCH		0.08	0.07	0.07	0.07	0.07	0.07	0.07	0.07	0.07	0.06
ROLL		-0.08	-0.07	-0.07	-0.07	-0.07	-0.07	-0.07	-0.07	-0.07	-0.07

229S15

## RUN 15-S. QUARTERING SEA, SES, APPROX. 10 KNOTS

	CHRONOLOGICAL OUTPUT		AVERAGE		AVE 1/3		AVE 1/10		EXTREME	
	PK	TR	PK	TR	PK	TR	PK	TR	PK	TR
PITCH	0.59	-0.62	0.73	-0.74	0.81	-0.85	0.81	-0.85	0.81	-0.85
ROLL	0.90	-0.89	1.23	-1.26	1.40	-1.71	1.40	-1.71	1.46	-1.71
VBOWAC	0.04	-0.03	0.05	-0.04	0.05	-0.05	0.07	-0.05	0.07	-0.05
VSTRNA	0.03	-0.03	0.04	-0.03	0.04	-0.03	0.04	-0.03	0.04	-0.04
VCGAC	0.03	-0.02	0.03	-0.02	0.04	-0.02	0.04	-0.02	0.04	-0.02
TRCGAC	0.04	-0.03	0.05	-0.05	0.05	-0.05	0.05	-0.05	0.06	-0.06
	RANKED OUTPUT? 2 6									
PITCH	0.81	0.65	0.55	0.54	0.50	0.49	0.50	0.50	0.49	0.50
ROLL	-0.65	-0.68	-0.67	-0.52	-0.50	-0.50	-0.50	-0.50	-0.50	-0.50
	RANKED OUTPUT? 3 16									
ROLL	1.46	1.42	1.42	1.37	1.32	1.27	1.32	1.32	1.27	1.22
VBOWAC	-1.71	-1.51	-1.51	-1.46	-1.46	-1.37	-1.37	-1.37	-1.37	-1.37
VSTRNA	1.22	1.22	1.17	1.17	1.12	1.12	1.12	1.12	1.12	1.12
VCGAC	-1.27	-1.17	-1.17	-1.12	-1.12	-1.07	-1.07	-1.07	-1.07	-1.03
	RANKED OUTPUT? 4 16									
VBOWAC	0.07	0.07	0.05	0.05	0.05	0.05	0.05	0.05	0.05	0.05
VSTRNA	-0.05	-0.05	-0.05	-0.05	-0.05	-0.05	-0.05	-0.05	-0.05	-0.05
VCGAC	0.05	0.05	0.05	0.05	0.05	0.05	0.05	0.05	0.05	0.05
TRCGAC	-0.05	-0.05	-0.05	-0.05	-0.05	-0.05	-0.05	-0.05	-0.05	-0.05
	RANKED OUTPUT? 5 16									
VSTRNA	0.04	0.04	0.04	0.04	0.04	0.03	0.03	0.03	0.03	0.03
VCGAC	-0.04	-0.03	-0.03	-0.03	-0.03	-0.03	-0.03	-0.03	-0.03	-0.03
VSTRNA	0.03	0.03	0.03	0.03	0.03	0.03	0.03	0.03	0.03	0.03
VCGAC	-0.03	-0.03	-0.03	-0.03	-0.03	-0.03	-0.03	-0.03	-0.03	-0.03
	RANKED OUTPUT? 6 16									
VCGAC	0.04	0.03	0.03	0.03	0.03	0.03	0.03	0.03	0.03	0.03
VSTRNA	-0.02	-0.02	-0.02	-0.02	-0.02	-0.02	-0.02	-0.02	-0.02	-0.02
VCGAC	0.03	0.03	0.02	0.02	0.02	0.02	0.02	0.02	0.02	0.02
TRCGAC	-0.02	-0.02	-0.02	-0.02	-0.02	-0.02	-0.02	-0.02	-0.02	-0.02
	RANKED OUTPUT? 7 16									
VCGAC	0.01	0.03	0.03	0.05	0.04	0.03	0.04	0.03	0.04	0.03
TRCGAC	-0.03	-0.04	-0.03	-0.03	-0.04	-0.04	-0.04	-0.03	-0.03	-0.03
	RANKED OUTPUT? 7 16									
TRCGAC	0.06	0.05	0.05	0.05	0.05	0.05	0.05	0.05	0.05	0.05
VCGAC	-0.06	-0.06	-0.05	-0.05	-0.05	-0.04	-0.04	-0.04	-0.04	-0.04
VSTRNA	0.04	0.04	0.04	0.04	0.04	0.04	0.04	0.04	0.04	0.04
TRCGAC	-0.04	-0.04	-0.04	-0.04	-0.04	-0.04	-0.04	-0.04	-0.04	-0.04
	RANKED OUTPUT? 7 16									
MEAN VALUE			NO. OF PEAKS		RMS					
WAVENT	-0.01		0		0.00					
PITCH	-0.01		6		0.27					
ROLL	0.00		56		0.58					
VBOWAC	0.00		149		0.02					
VSTRNA	-0.00		44		0.01					
VCGAC	0.00		21		0.02					
TRCGAC	-0.00		47		0.02					
LMCGAC	-0.04		0		0.00					

SEAWORTHINESS TEST RESULTS IN SEA STATE 2 (29 FEB 1980)

229W15

RUN 15 S.QUARTERING SEA, WPB, APPROX. 10 KNOTS

CHRONOLOGICAL OUTPUT?	AVERAGE			AVE 1/3			AVE 1/10			EXTREME		
	PK	TR	TR	PK	TR	TR	PK	TR	TR	PK	TR	TR
PITCH	1.04	0.93	0.42	0.52	0.68	0.47	1.09	0.29	1.11	1.33	1.14	-1.46
ROLL	-0.39	-0.34	-1.46	-0.93	-0.68	-0.59	-0.80	-1.20	4.76	-4.12	6.25	-4.98
PITCH	0.62	0.75	0.83	0.57	0.73	0.47	0.73	0.55	0.13	-0.09	0.29	-0.15
ROLL	-1.11	-1.03	-0.62	-0.54	-0.54	-0.62	-0.68	-1.01	0.06	-0.07	0.13	-0.07
									0.06	-0.04	0.09	-0.04
									0.10	-0.10	0.12	-0.13

CHRONOLOGICAL OUTPUT?	RANKEU OUTPUT?			RANKEU OUTPUT?			RANKEU OUTPUT?		
	PK	TR	TR	PK	TR	TR	PK	TR	TR
PITCH	2.39	-0.05	0.24	2.69	-0.29	4.74	2.10	-0.54	0.88
ROLL	-1.71	-1.76	-1.51	-1.95	-1.46	-4.39	-1.17	-1.95	-0.80
PITCH	0.93	3.12	2.15	2.98	1.03	1.22	2.93	1.46	0.62
ROLL	-2.05	-1.03	-2.15	-1.17	-2.00	-3.42	-2.39	0.10	-0.54

CHRONOLOGICAL OUTPUT?	RANKEU OUTPUT?			RANKEU OUTPUT?			RANKEU OUTPUT?		
	PK	TR	TR	PK	TR	TR	PK	TR	TR
PITCH	0.00	0.07	0.07	0.02	0.05	0.03	0.03	0.03	0.85
ROLL	-0.07	-0.05	-0.07	-0.03	-0.03	-0.02	-0.02	-0.03	-0.80
PITCH	0.05	0.02	0.05	0.08	0.05	0.08	0.05	0.08	0.57
ROLL	-0.07	-0.03	-0.05	-0.07	-0.08	-0.05	-0.03	-0.07	-0.54

CHRONOLOGICAL OUTPUT?	RANKEU OUTPUT?			RANKEU OUTPUT?			RANKEU OUTPUT?		
	PK	TR	TR	PK	TR	TR	PK	TR	TR
PITCH	0.02	-0.02	0.02	0.00	0.04	0.02	0.02	0.13	0.15
ROLL	-0.03	-0.05	-0.06	-0.05	-0.07	-0.05	-0.03	-0.07	-0.10
PITCH	0.00	0.02	0.02	0.02	0.02	0.02	0.02	0.10	0.10
ROLL	-0.06	-0.05	-0.03	-0.03	-0.06	-0.06	-0.03	-0.08	-0.08

CHRONOLOGICAL OUTPUT?	RANKEU OUTPUT?			RANKEU OUTPUT?			RANKEU OUTPUT?		
	PK	TR	TR	PK	TR	TR	PK	TR	TR
PITCH	0.04	0.03	0.03	0.03	0.24	0.35	0.04	0.03	0.06
ROLL	-0.02	-0.03	-0.02	-0.03	-0.02	0.13	-0.02	-0.02	-0.07
PITCH	0.03	0.03	0.03	0.06	0.06	0.04	0.03	0.03	0.03
ROLL	-0.02	-0.02	-0.02	-0.02	0.00	-0.02	-0.03	-0.02	-0.07

CHRONOLOGICAL OUTPUT?	RANKEU OUTPUT?			RANKEU OUTPUT?			RANKEU OUTPUT?		
	PK	TR	TR	PK	TR	TR	PK	TR	TR
PITCH	0.04	0.03	0.04	0.09	0.02	0.06	0.04	0.02	0.06
ROLL	-0.02	-0.07	-0.03	-0.06	-0.13	-0.04	-0.01	-0.03	-0.04
PITCH	0.05	0.04	0.05	0.08	0.06	0.06	0.05	0.04	0.05
ROLL	-0.06	-0.05	-0.08	-0.03	-0.04	-0.05	-0.01	-0.02	-0.03

MEAN VALUE	NO. OF PEAKS	RMS	RANKEU OUTPUT?		
			PK	TR	TR
FITCH	0.01	21	0.36	0.09	0.09
ROLL	-0.05	86	1.78	-0.09	-0.09
VRQWAC	0.00	234	0.02	0.08	0.08
VSTRNA	-0.01	132	0.02	0.08	0.08
VCGAC	0.01	123	0.02	-0.08	-0.08
TRCGAC	0.04	77	0.04	-0.08	-0.08

SEAWORTHINESS TEST RESULTS IN SEA STATE 2 (29 FEB 1980)

229S16

RUN 16 HEAD SEA, SES, APPROX. 15 KNOTS

	AVERAGE		AVE 1/3		AVE 1/10		EXTREME	
	PK	TR	PK	TR	PK	TR	PK	TR
PITCH	0.54	-0.72	0.74	-0.92	0.91	-1.14	1.12	-1.43
ROLL	0.55	-0.51	0.63	-0.59	0.73	-0.63	0.73	-0.63
VBOWAC	0.21	-0.16	0.27	-0.27	0.32	-0.37	0.41	-0.54
VSTRNA	0.27	-0.08	0.41	-0.12	0.52	-0.17	0.69	-0.24
VCBAC	0.18	-0.07	0.22	-0.10	0.27	-0.14	0.32	-0.14
TRCGAC	0.02	-0.06	0.05	-0.07	0.09	-0.07	0.13	-0.08

CHRONOLOGICAL OUTPUT?		2 16
PITCH	0.78	0.28
ROLL	-0.62	-0.86
VSTRNA	0.57	0.50
VCBAC	-0.60	-0.75
TRCGAC	-0.75	-0.50

CHRONOLOGICAL OUTPUT?		3 16
ROLL	0.59	0.59
VBOWAC	-0.39	-0.54
VSTRNA	0.49	0.49
VCBAC	-0.54	-0.49
TRCGAC	-0.63	-0.49

CHRONOLOGICAL OUTPUT?		4 16
VBOWAC	0.20	0.16
VSTRNA	-0.05	-0.07
VCBAC	0.20	0.15
TRCGAC	-0.21	-0.13

CHRONOLOGICAL OUTPUT?		5 16
VSTRNA	0.18	0.17
VCBAC	-0.07	-0.05
TRCGAC	0.25	0.18
TRCGAC	-0.07	-0.05

CHRONOLOGICAL OUTPUT?		6 16
VCBAC	0.16	0.25
TRCGAC	-0.10	-0.04
TRCGAC	0.20	0.13
TRCGAC	-0.04	-0.07

CHRONOLOGICAL OUTPUT?		7 16
TRCGAC	0.02	0.01
TRCGAC	-0.08	-0.05
TRCGAC	0.00	0.03
TRCGAC	-0.07	-0.06

	MEAN VALUE	NO. OF PEAKS	RMS
WAVEHT	-0.01	0	0.00
PITCH	-0.00	67	0.42
ROLL	0.03	17	0.22
VBOWAC	0.05	337	0.10
VSTRNA	0.04	257	0.08
VCBAC	0.05	78	0.04
TRCGAC	-0.03	80	0.01
LMCGAC	-0.04	0	0.00

RANKED OUTPUT?		2 16
PITCH	1.12	1.11
ROLL	-1.43	-1.24
PITCH	0.76	0.73
ROLL	-0.90	-0.88

RANKED OUTPUT?		3 16
ROLL	0.73	0.63
ROLL	-0.63	-0.59
ROLL	0.54	0.54
ROLL	-0.49	-0.49

RANKED OUTPUT?		4 16
VBOWAC	0.41	0.39
VBOWAC	-0.54	-0.52
VBOWAC	0.34	0.34
VBOWAC	-0.39	-0.39

RANKED OUTPUT?		5 16
VSTRNA	0.69	0.65
VSTRNA	-0.24	-0.23
VSTRNA	0.54	0.52
VSTRNA	-0.17	-0.17

RANKED OUTPUT?		6 16
VCBAC	0.32	0.29
VCBAC	-0.16	-0.15
VCBAC	0.24	0.23
VCBAC	-0.11	-0.11

RANKED OUTPUT?		7 16
TRCGAC	0.13	0.12
TRCGAC	-0.08	-0.08
TRCGAC	0.04	0.04
TRCGAC	-0.07	-0.07

SEAWORTHINESS TEST RESULTS IN SEA STATE 2 (29 FEB 1980)

229W16

RUN 16 HEAD SEA, WPB, APPROX. 15 KNOTS

	CHRONOLOGICAL OUTPUT? 1 16				AVERAGE 1/3				AVE 1/10				EXTREME	
	PK	TR	PK	TR	PK	TR	PK	TR	PK	TR	PK	TR	PK	TR
PITCH	1.48	1.45	1.66	1.55	1.35	1.37	1.63	1.46	1.57	1.74	1.86	1.86	1.86	-2.05
ROLL	0.07	0.13	0.29	0.36	0.29	0.34	0.29	0.29	1.36	-1.48	2.84	2.84	2.84	-2.69
FITCH	1.27	1.30	1.42	1.63	1.86	1.58	1.30	1.45	1.70	-1.73	2.31	2.31	2.31	-0.90
VEGAC	-0.21	0.03	0.28	0.08	-0.16	-0.20	0.10	0.08	0.48	-0.52	0.48	0.48	0.48	-0.33
VCGAC	0.10	0.03	0.28	0.08	-0.16	-0.20	0.10	0.08	0.19	-0.21	0.24	0.24	0.24	-0.37
TRCGAC	0.03	-0.04	-0.04	-0.06	-0.06	-0.06	-0.06	-0.06	0.15	-0.16	0.19	0.19	0.19	-0.07
TRCGAC	0.03	-0.04	-0.04	-0.06	-0.06	-0.06	-0.06	-0.06	0.05	-0.06	0.07	0.07	0.07	-0.09
RANKED OUTPUT? 1 16														
PITCH	1.86	1.68	1.68	1.64	1.64	1.63	1.58	1.56	1.63	1.63	1.63	1.63	1.63	1.58
ROLL	-2.05	-2.02	-1.89	-1.86	-1.77	-1.76	-1.71	-1.71	-1.77	-1.76	-1.71	-1.71	-1.71	-1.71
FITCH	1.55	1.51	1.51	1.50	1.50	1.48	1.46	1.45	1.51	1.50	1.48	1.48	1.46	1.45
VEGAC	-1.69	-1.68	-1.64	-1.64	-1.63	-1.61	-1.61	-1.58	-1.63	-1.61	-1.61	-1.61	-1.61	-1.58
RANKED OUTPUT? 2 16														
ROLL	2.64	2.25	2.20	2.15	2.15	1.86	1.66	1.61	2.20	2.15	1.86	1.71	1.66	1.61
ROLL	-2.69	-2.34	-2.25	-2.00	-1.90	-1.76	-1.71	-1.71	-2.00	-1.90	-1.76	-1.71	-1.71	-1.71
ROLL	1.42	1.42	1.42	1.37	1.37	1.37	1.22	1.17	1.42	1.37	1.37	1.27	1.22	1.17
VEGAC	-1.66	-1.56	-1.46	-1.37	-1.27	-1.17	-1.12	-1.03	-1.56	-1.37	-1.27	-1.17	-1.12	-1.03
RANKED OUTPUT? 3 16														
VEGAC	0.67	0.65	0.65	0.57	0.54	0.52	0.50	0.50	0.65	0.57	0.54	0.52	0.50	0.50
VEGAC	-0.90	-0.70	-0.68	-0.65	-0.60	-0.60	-0.55	-0.55	-0.68	-0.65	-0.60	-0.60	-0.59	-0.55
VEGAC	0.49	0.49	0.49	0.47	0.47	0.47	0.46	0.46	0.49	0.47	0.47	0.47	0.46	0.46
VEGAC	-0.54	-0.54	-0.52	-0.52	-0.50	-0.49	-0.49	-0.49	-0.52	-0.52	-0.50	-0.49	-0.49	-0.49
RANKED OUTPUT? 4 16														
VEGAC	0.33	0.29	0.28	0.27	0.27	0.26	0.25	0.25	0.29	0.28	0.27	0.26	0.26	0.25
VEGAC	-0.43	-0.35	-0.33	-0.32	-0.31	-0.30	-0.28	-0.28	-0.33	-0.32	-0.31	-0.30	-0.29	-0.28
VEGAC	0.25	0.25	0.25	0.24	0.24	0.24	0.24	0.24	0.25	0.24	0.24	0.24	0.24	0.24
VEGAC	-0.27	-0.27	-0.26	-0.25	-0.25	-0.25	-0.24	-0.24	-0.27	-0.25	-0.25	-0.24	-0.24	-0.24
RANKED OUTPUT? 5 16														
VEGAC	0.24	0.23	0.23	0.23	0.23	0.23	0.21	0.21	0.23	0.23	0.23	0.21	0.21	0.21
VEGAC	-0.37	-0.28	-0.28	-0.27	-0.25	-0.25	-0.24	-0.24	-0.28	-0.27	-0.25	-0.25	-0.24	-0.24
VEGAC	0.20	0.20	0.20	0.19	0.19	0.19	0.18	0.18	0.20	0.19	0.19	0.19	0.18	0.18
VEGAC	-0.24	-0.23	-0.21	-0.21	-0.21	-0.20	-0.20	-0.20	-0.23	-0.21	-0.21	-0.20	-0.20	-0.20
RANKED OUTPUT? 6 16														
VEGAC	0.07	0.07	0.07	0.07	0.07	0.06	0.06	0.06	0.07	0.07	0.06	0.06	0.06	0.06
VEGAC	-0.09	-0.08	-0.07	-0.07	-0.07	-0.07	-0.06	-0.06	-0.07	-0.07	-0.07	-0.07	-0.06	-0.06
VEGAC	0.06	0.06	0.06	0.05	0.05	0.05	0.05	0.05	0.06	0.05	0.05	0.05	0.05	0.05
VEGAC	-0.06	-0.06	-0.06	-0.06	-0.06	-0.06	-0.06	-0.06	-0.06	-0.06	-0.06	-0.06	-0.06	-0.06

	MEAN VALUE	NO. OF PEAKS	RMS
PITCH	0.01	167	0.69
ROLL	-0.00	47	0.78
VEGAC	0.01	289	0.18
VEGAC	-0.00	284	0.10
VEGAC	0.01	266	0.08
VEGAC	-0.01	82	0.02

SEAWORTHINESS TEST RESULTS IN SEA STATE 2 (29 FEB 1980)

229S17

RUN 17 FOLLOWING SEA, SES, APPROX. 16 KNOTS

CHRONOLOGICAL OUTPUT?	2 16				AVERAGE				AVE 1/10				EXTREME	
	PK	TR	PK	TR	PK	TR	PK	TR	PK	TR	PK	TR	PK	TR
PITCH	1.53	1.12	0.39	0.67	0.52	0.67	0.67	0.67	0.67	0.67	0.67	0.67	1.53	-1.43
	-1.22	-1.38	-1.11	-1.03	-1.43	-0.83	-0.90	-0.91					0.83	-0.83
FITCH	0.46	1.04	1.09	1.06	1.24	0.78	0.49	0.80					0.20	-0.04
	-0.81	-0.93	-0.41	-0.78	-0.29	-0.54	-0.57	-0.52					0.00	-0.00

CHRONOLOGICAL OUTPUT?	3 15				RANKED OUTPUT?				2 16					
	PK	TR	PK	TR	PK	TR	PK	TR	PK	TR	PK	TR		
ROLL	0.78	0.68	0.68	0.54	0.44	0.44	0.39	0.44	1.53	1.24	1.12	1.09	1.04	0.80
	-0.83	-0.49	-0.63	-0.49	-0.59	-0.63	-0.68	-0.78	-1.43	-1.38	-1.22	-1.11	-1.03	-0.91
ROLL	0.54	0.73	0.73	0.83	0.49	0.73	0.49	0.49	0.67	0.67	0.67	0.67	0.52	0.46
	-0.73	-0.59	-0.54	-0.54	-0.73	-0.49	-0.49	0.00	-0.83	-0.81	-0.78	-0.57	-0.54	-0.41

CHRONOLOGICAL OUTPUT?	4 16				RANKED OUTPUT?				3 15					
	PK	TR	PK	TR	PK	TR	PK	TR	PK	TR	PK	TR		
VBOWAC	0.11	0.11	0.11	0.11	0.11	0.13	0.13	0.13	0.83	0.78	0.73	0.73	0.68	0.54
	0.00	0.00	-0.05	0.00	-0.03	-0.03	-0.08	-0.02	-0.83	-0.78	-0.73	-0.68	-0.63	-0.59
VBOWAC	0.10	0.11	0.11	0.11	0.11	0.11	0.10	0.10	0.54	0.49	0.44	0.44	0.44	0.39
	0.00	0.00	-0.07	0.00	0.00	-0.02	0.00	0.00	-0.59	-0.54	-0.54	-0.49	-0.49	-0.49

CHRONOLOGICAL OUTPUT?	5 16				RANKED OUTPUT?				4 16					
	PK	TR	PK	TR	PK	TR	PK	TR	PK	TR	PK	TR		
VSTRNA	0.11	0.12	0.13	0.09	0.09	0.14	0.10	0.09	0.20	0.16	0.15	0.15	0.15	0.15
	-0.02	-0.02	-0.02	-0.02	-0.02	-0.02	-0.02	-0.02	-0.13	-0.08	-0.07	-0.07	-0.07	-0.07
VSTRNA	0.10	0.11	0.09	0.08	0.15	0.20	0.12	0.11	0.15	0.13	0.13	0.13	0.13	0.13
	-0.01	-0.06	-0.02	-0.02	-0.06	-0.05	-0.03	0.00	-0.05	-0.05	-0.05	-0.05	-0.05	-0.05

CHRONOLOGICAL OUTPUT?	7 14				RANKED OUTPUT?				5 16					
	PK	TR	PK	TR	PK	TR	PK	TR	PK	TR	PK	TR		
TRCGAC	0.01	0.05	0.08	0.02	0.02	0.04	0.00	0.02	0.20	0.15	0.14	0.13	0.12	0.11
	-0.05	-0.06	-0.02	-0.05	-0.05	-0.05	-0.05	-0.06	-0.06	-0.05	-0.03	-0.03	-0.02	-0.02
TRCGAC	0.02	0.04	0.00	0.03	0.00	0.00	0.00	0.00	0.11	0.11	0.10	0.10	0.10	0.10
	-0.06	-0.05	-0.06	-0.06	-0.05	-0.05	-0.05	-0.06	-0.02	-0.02	-0.02	-0.02	-0.02	-0.02

MEAN VALUE	NO. OF PEAKS	RMS	RANKED OUTPUT?	
			7 14	5 16
WAVEHT	0	0.00	0.08	0.02
PITCH	16	0.45	0.05	0.04
ROLL	15	0.27	-0.06	-0.06
VBOWAC	166	0.03	0.01	0.00
VSTRNA	32	0.02	-0.05	-0.05
VCGAC	0	0.01	0.00	0.00
TRCGAC	14	0.01	-0.05	-0.05
LNCGAC	0	0.00	0.00	0.00

## SEAWORTHINESS TEST RESULTS IN SEA STATE 2 (29 FEB 1980)

RUN 17 FOLLOWING SEA, WPB, APPROX. 16 KNOTS

229W17

	CHRONOLOGICAL OUTPUT? 1 16				AVERAGE 173				AVE 1/10				EXTREME			
	PK	TR	PK	TR	PK	TR	PK	TR	PK	TR	PK	TR	PK	TR	PK	TR
PITCH	0.91	1.19	0.99	1.30	1.24	1.71	1.19	0.93	0.93	-0.45	1.32	-0.74	1.71	-0.83	1.71	-0.83
ROLL	-0.24	-0.57	-0.23	-0.57	-0.05	0.03	0.15	-0.07	1.69	-1.87	3.38	-3.88	4.53	-5.04	5.13	-6.15
PITCH	1.01	1.29	0.83	0.99	0.81	0.70	0.70	0.50	0.06	-0.06	0.09	-0.10	-0.16	0.20	-0.23	
ROLL	-0.21	-0.65	-0.59	-0.55	-0.70	-0.68	-0.62	-0.63	0.04	-0.04	0.05	-0.07	0.08	-0.09	0.13	-0.14
									VCGAC	0.04	0.06	-0.06	0.06	-0.06	0.10	-0.11
									TRCGAC	0.06	-0.04	0.09	-0.07	0.10	-0.09	-0.10
									RANKED OUTPUT? 1 16							
									PITCH	1.71	1.30	1.29	1.24	1.19	1.01	0.99
									ROLL	-0.83	-0.80	-0.80	-0.70	-0.68	-0.62	-0.59
									PITCH	0.99	0.93	0.91	0.83	0.81	0.70	0.50
									ROLL	-0.57	-0.57	-0.55	-0.26	-0.23	-0.21	-0.07
									RANKED OUTPUT? 2 16							
									PITCH	5.13	4.88	4.83	4.35	3.47	3.37	3.27
									ROLL	-6.15	-5.32	-4.83	-4.44	-4.44	-4.15	-4.05
									PITCH	3.22	3.17	2.98	2.98	2.93	2.83	2.78
									ROLL	-3.91	-3.86	-3.76	-3.56	-3.52	-3.22	-3.08
									RANKED OUTPUT? 3 16							
									PITCH	0.20	0.20	0.16	0.16	0.16	0.15	0.15
									ROLL	-0.23	-0.23	-0.20	-0.20	-0.18	-0.16	-0.16
									PITCH	0.15	0.15	0.13	0.13	0.13	0.13	0.13
									ROLL	-0.16	-0.16	-0.16	-0.16	-0.15	-0.15	-0.15
									RANKED OUTPUT? 4 16							
									PITCH	0.13	0.10	0.10	0.09	0.09	0.08	0.07
									ROLL	-0.14	-0.12	-0.11	-0.11	-0.10	-0.09	-0.09
									PITCH	0.07	0.07	0.07	0.07	0.07	0.07	0.07
									ROLL	-0.09	-0.08	-0.08	-0.07	-0.07	-0.07	-0.07
									RANKED OUTPUT? 5 16							
									PITCH	0.10	0.10	0.10	0.09	0.09	0.08	0.07
									ROLL	-0.11	-0.10	-0.09	-0.08	-0.08	-0.07	-0.07
									PITCH	0.07	0.07	0.07	0.07	0.07	0.07	0.06
									ROLL	-0.07	-0.07	-0.07	-0.07	-0.07	-0.07	-0.07
									RANKED OUTPUT? 6 16							
									PITCH	0.10	0.10	0.10	0.09	0.09	0.08	0.07
									ROLL	-0.11	-0.10	-0.09	-0.09	-0.08	-0.08	-0.07
									PITCH	0.07	0.07	0.07	0.07	0.07	0.07	0.06
									ROLL	-0.07	-0.07	-0.07	-0.07	-0.07	-0.07	-0.07
									RANKED OUTPUT? 7 16							
									PITCH	0.12	0.10	0.10	0.10	0.09	0.09	0.09
									ROLL	-0.10	-0.09	-0.09	-0.09	-0.08	-0.08	-0.06
									PITCH	0.08	0.08	0.08	0.07	0.07	0.07	0.06
									ROLL	-0.06	-0.06	-0.06	-0.05	-0.05	-0.05	-0.05

	MEAN VALUE	NO. OF PEAKS	RMS
PITCH	0.01	19	0.48
ROLL	-0.02	57	1.91
VBOWAC	0.00	267	0.04
VSTRNA	-0.00	151	0.02
VCGAC	0.00	126	0.02
TRCGAC	0.00	40	0.04

SEAWORTHINESS TEST RESULTS IN SEA STATE 2 (29 FEB 1980)

RUN 18 S. BEAM SEA, SES, APPROX. 16 KNOTS

229S18

CHRONOLOGICAL OUTPUT? 2 16		AVERAGE		AVE 1/3		AVE 1/10		EXTREME	
		PK	TR	PK	TR	PK	TR	PK	TR
PITCH	0.67 0.39 0.63 0.46 0.34 0.55 0.37 0.55	0.46	-0.83	0.69	-0.98	0.98	-1.03	0.98	-1.03
	-0.75 -0.83 -0.86 -0.55 -1.01 -0.98 -0.65 -1.03	1.67	-1.44	2.51	-2.24	3.26	-2.73	4.25	-3.12
PITCH	0.39 0.98 0.23 0.68 0.62 0.41 0.37 0.16	0.13	-0.02	0.16	-0.06	0.18	-0.10	0.28	-0.16
	-0.91 -0.73 -0.86 -0.86 -0.80 -0.59 -0.72 -0.86	0.11	-0.02	0.14	-0.04	0.18	-0.07	0.28	-0.10
		0.11	-0.01	0.12	-0.03	0.14	-0.04	0.16	-0.09
		0.03	-0.08	0.06	-0.11	0.10	-0.14	0.15	-0.16
RANKED OUTPUT? 2 16									
PITCH	0.97 0.68 0.67 0.63 0.62 0.55 0.55 0.46	-1.03	-1.01	-0.99	-0.98	-0.94	-0.91	-0.86	-0.86
PITCH	0.41 0.39 0.39 0.37 0.37 0.37 0.34 0.23	-0.86	-0.86	-0.83	-0.80	-0.75	-0.73	-0.72	-0.65
RANKED OUTPUT? 3 16									
ROLL	4.25 3.61 3.42 3.37 3.37 3.22 3.17	-3.12	-3.12	-3.03	-2.93	-2.83	-2.78	-2.54	-2.54
ROLL	2.98 2.83 2.69 2.64 2.59 2.54 2.44	-2.49	-2.49	-2.44	-2.44	-2.39	-2.39	-2.34	-2.34
RANKED OUTPUT? 4 16									
VBOWAC	0.28 0.23 0.20 0.20 0.20 0.20 0.20	-0.16	-0.13	-0.13	-0.13	-0.13	-0.11	-0.11	-0.11
VBOWAC	0.20 0.20 0.18 0.18 0.18 0.18 0.19	-0.11	-0.11	-0.11	-0.10	-0.10	-0.10	-0.10	-0.10
RANKED OUTPUT? 5 16									
VSTRNA	0.28 0.21 0.20 0.19 0.19 0.18 0.17	-0.10	-0.10	-0.08	-0.07	-0.07	-0.07	-0.07	-0.07
VSTRNA	0.16 0.16 0.15 0.15 0.15 0.15 0.15	-0.07	-0.06	-0.06	-0.06	-0.06	-0.06	-0.05	-0.05
RANKED OUTPUT? 6 16									
VCGAC	0.16 0.16 0.15 0.13 0.13 0.13 0.12	-0.09	-0.05	-0.03	-0.03	-0.03	-0.03	-0.03	-0.03
VCGAC	0.12 0.12 0.12 0.12 0.12 0.12 0.12	-0.03	-0.03	-0.03	-0.03	-0.03	-0.03	-0.03	-0.02
RANKED OUTPUT? 7 16									
TRCGAC	0.15 0.12 0.12 0.12 0.12 0.11 0.11	-0.16	-0.16	-0.16	-0.15	-0.15	-0.15	-0.14	-0.13
TRCGAC	0.10 0.10 0.10 0.09 0.09 0.09 0.08	-0.13	-0.13	-0.13	-0.13	-0.12	-0.12	-0.12	-0.12
MEAN VALUE NO. OF PEAKS RMS									
JAVENT	-0.02	0	0.00						
PITCH	-0.20	18	0.30						
ROLL	0.10	120	1.16						
VBOWAC	0.05	399	0.05						
VSTRNA	0.04	176	0.03						
VCGAC	0.05	113	0.02						
TRCGAC	-0.03	176	0.04						
LMCGAC	-0.04	0	0.00						

SEAWORTHINESS TEST RESULTS IN SEA STATE 2 (29 FEB 1980)

229W18

RUN 18 S.BEAM SEA, WPB, APPROX. 16 KNOTS

	CHRONOLOGICAL OUTPUT		AVERAGE		AVE 1/3		AVE 1/10		EXTREME	
	PK	TR	PK	TR	PK	TR	PK	TR	PK	TR
PITCH	0.41	0.99	0.63	0.91	0.72	0.46	0.75	0.67	1.63	-1.50
ROLL	-1.48	-1.30	-0.67	-0.98	-1.05	-1.04	-0.59	1.37	-1.38	1.63
VRMAC	0.09	0.09	0.10	0.10	0.10	0.10	0.10	7.30	-7.25	8.30
VSTRNA	0.06	0.06	0.07	0.07	0.11	0.12	0.15	0.19	0.28	-0.29
VCGAC	0.06	0.06	0.06	0.06	0.09	0.09	0.11	0.11	0.16	-0.16
TRCGAC	0.08	0.08	-0.08	-0.08	0.13	0.14	0.17	0.17	0.19	-0.22
RANKED OUTPUT? 1 16										
PITCH	1.63	1.55	1.35	1.19	1.14	1.09	0.99	0.99	0.99	0.93
ROLL	-1.50	-1.48	-1.38	-1.30	-1.22	-1.22	-1.06	-1.04	-1.06	-1.04
VRMAC	0.93	0.91	0.90	0.86	0.85	0.85	0.81	0.81	0.81	0.80
VSTRNA	-1.04	-0.98	-0.93	-0.93	-0.90	-0.85	-0.85	-0.85	-0.85	-0.81
VCGAC	0.93	0.91	0.90	0.86	0.85	0.85	0.81	0.81	0.81	0.80
TRCGAC	-1.04	-0.98	-0.93	-0.93	-0.90	-0.85	-0.85	-0.85	-0.85	-0.81
RANKED OUTPUT? 2 16										
PITCH	8.30	8.30	8.11	7.03	6.88	6.84	6.79	6.79	6.79	6.79
ROLL	-8.20	-7.96	-7.57	-7.47	-6.98	-6.98	-6.93	-6.59	-6.93	-6.59
VRMAC	6.64	6.64	6.35	6.30	6.15	6.05	5.81	5.62	6.05	5.62
VSTRNA	-6.54	-6.49	-6.30	-5.86	-5.86	-5.66	-5.37	-5.32	-5.86	-5.32
VCGAC	6.64	6.64	6.35	6.30	6.15	6.05	5.81	5.62	6.05	5.62
TRCGAC	-6.54	-6.49	-6.30	-5.86	-5.86	-5.66	-5.37	-5.32	-5.86	-5.32
RANKED OUTPUT? 3 16										
PITCH	0.28	0.24	0.23	0.21	0.21	0.20	0.20	0.20	0.20	0.20
ROLL	-0.29	-0.26	-0.23	-0.23	-0.23	-0.21	-0.21	-0.20	-0.21	-0.20
VRMAC	0.20	0.20	0.20	0.20	0.18	0.18	0.18	0.18	0.18	0.18
VSTRNA	-0.20	-0.20	-0.20	-0.20	-0.20	-0.20	-0.20	-0.18	-0.20	-0.18
VCGAC	0.20	0.20	0.20	0.20	0.18	0.18	0.18	0.18	0.18	0.18
TRCGAC	-0.20	-0.20	-0.20	-0.20	-0.20	-0.20	-0.20	-0.18	-0.20	-0.18
RANKED OUTPUT? 4 16										
PITCH	0.31	0.29	0.24	0.23	0.21	0.20	0.19	0.19	0.19	0.19
ROLL	-0.22	-0.20	-0.20	-0.19	-0.17	-0.17	-0.16	-0.16	-0.16	-0.16
VRMAC	0.18	0.18	0.17	0.15	0.15	0.15	0.14	0.13	0.15	0.13
VSTRNA	-0.15	-0.15	-0.15	-0.15	-0.15	-0.14	-0.13	-0.13	-0.13	-0.13
VCGAC	0.18	0.18	0.17	0.15	0.15	0.15	0.14	0.13	0.15	0.13
TRCGAC	-0.15	-0.15	-0.15	-0.15	-0.15	-0.14	-0.13	-0.13	-0.13	-0.13
RANKED OUTPUT? 5 16										
PITCH	0.16	0.14	0.13	0.13	0.12	0.11	0.11	0.11	0.11	0.11
ROLL	-0.16	-0.15	-0.15	-0.13	-0.13	-0.13	-0.13	-0.13	-0.13	-0.13
VRMAC	0.11	0.11	0.11	0.11	0.11	0.11	0.10	0.10	0.11	0.10
VSTRNA	-0.12	-0.11	-0.11	-0.11	-0.11	-0.11	-0.11	-0.11	-0.11	-0.11
VCGAC	0.11	0.11	0.11	0.11	0.11	0.11	0.10	0.10	0.11	0.10
TRCGAC	-0.12	-0.11	-0.11	-0.11	-0.11	-0.11	-0.11	-0.11	-0.11	-0.11
RANKED OUTPUT? 6 16										
PITCH	0.19	0.17	0.17	0.17	0.17	0.17	0.16	0.16	0.16	0.16
ROLL	-0.22	-0.19	-0.19	-0.18	-0.18	-0.18	-0.17	-0.17	-0.17	-0.17
VRMAC	0.16	0.16	0.16	0.16	0.15	0.15	0.14	0.14	0.14	0.14
VSTRNA	-0.17	-0.16	-0.16	-0.16	-0.16	-0.16	-0.16	-0.16	-0.16	-0.16
VCGAC	0.16	0.16	0.16	0.16	0.15	0.15	0.14	0.14	0.14	0.14
TRCGAC	-0.17	-0.16	-0.16	-0.16	-0.16	-0.16	-0.16	-0.16	-0.16	-0.16

	MEAN VALUE	NO. OF PEAKS	RMS
PITCH	0.01	51	0.42
ROLL	0.00	97	2.85
VRMAC	-0.00	270	0.07
VSTRNA	-0.00	231	0.06
VCGAC	0.00	214	0.04
TRCGAC	0.00	112	0.07

## SEAWORTHINESS TEST RESULTS IN SEA STATE 2 (29 FEB 1980)

RUN 19 P. BOW SEA, SES, APPROX. 16 KNOTS

229S19

	CHRONOLOGICAL OUTPUT? 2 16				AVERAGE				AVE 1/3				AVE 1/10				EXTREME			
	PK	TR	PK	TR	PK	TR	PK	TR	PK	TR	PK	TR	PK	TR	PK	TR	PK	TR		
PITCH	0.59	0.67	0.57	0.85	0.57	0.93	0.34	0.29	0.62	-0.72	0.83	-1.00	0.94	-1.08	1.03	-1.14	1.03	-1.14		
ROLL	-0.52	-0.68	-0.44	-0.44	-0.98	-0.73	-1.14	-1.01	1.04	-0.99	1.53	-1.48	1.90	-1.83	2.25	-2.34	2.25	-2.34		
VBOWAC	0.17	-0.09	0.24	0.33	0.81	0.86	0.80	0.44	0.17	-0.09	0.24	-0.23	0.30	-0.37	0.44	-0.73	0.44	-0.73		
VSTRNA	0.59	0.62	0.50	0.33	0.81	0.86	0.80	0.44	0.17	-0.09	0.24	-0.23	0.30	-0.37	0.44	-0.73	0.44	-0.73		
VCGAC	-1.04	-0.88	-0.49	-0.80	-0.78	-0.52	-0.34	-0.72	0.13	-0.03	0.16	-0.06	0.21	-0.12	0.41	-0.32	0.41	-0.32		
TRCGAC	0.02	-0.08	-0.08	-0.08	-0.08	-0.08	-0.08	-0.08	0.02	-0.08	0.04	-0.10	0.07	-0.11	0.11	-0.15	0.11	-0.15		
	RANKED OUTPUT? 2 16																			
ROLL	1.27	1.07	1.56	0.68	1.56	1.03	2.05	0.93	1.03	0.94	0.93	0.88	0.86	0.85	0.81	0.80	0.81	0.80		
	-0.49	-0.54	-0.73	-0.49	-0.68	-0.68	-1.61	-0.73	-1.14	-1.11	-1.04	-1.04	-1.03	-1.01	-0.98	-0.98	-0.98	-0.98		
PITCH	0.73	0.78	1.03	1.12	0.68	0.93	1.07	1.90	0.80	0.76	0.73	0.72	0.68	0.67	0.67	0.65	0.67	0.65		
	-0.98	-0.59	-0.98	-0.98	-0.44	-0.35	-0.24	-1.12	-0.98	-0.96	-0.94	-0.93	-0.88	-0.88	-0.81	-0.80	-0.81	-0.80		
	RANKED OUTPUT? 3 16																			
ROLL	2.25	2.05	1.95	1.90	1.86	1.86	1.81	1.81	2.25	2.05	1.95	1.90	1.86	1.86	1.81	1.81	1.81	1.81		
	-2.34	-2.15	-2.05	-1.86	-1.71	-1.71	-1.66	-1.61	-2.34	-2.15	-2.05	-1.86	-1.71	-1.71	-1.66	-1.61	-1.66	-1.61		
PITCH	1.81	1.76	1.71	1.66	1.66	1.61	1.61	1.61	1.81	1.76	1.71	1.66	1.66	1.61	1.61	1.61	1.61	1.61		
	-1.61	-1.61	-1.56	-1.56	-1.56	-1.51	-1.46	-1.46	-1.61	-1.61	-1.56	-1.56	-1.51	-1.51	-1.51	-1.46	-1.46	-1.46		
	RANKED OUTPUT? 4 16																			
VBOWAC	0.44	0.42	0.39	0.36	0.36	0.34	0.33	0.33	0.44	0.42	0.39	0.36	0.36	0.34	0.33	0.33	0.33	0.33		
	-0.73	-0.65	-0.62	-0.59	-0.59	-0.57	-0.49	-0.49	-0.73	-0.65	-0.62	-0.59	-0.59	-0.57	-0.52	-0.49	-0.52	-0.49		
VSTRNA	0.33	0.33	0.31	0.31	0.29	0.29	0.29	0.29	0.33	0.33	0.31	0.31	0.29	0.29	0.29	0.29	0.29	0.29		
	-0.44	-0.42	-0.39	-0.39	-0.39	-0.39	-0.37	-0.37	-0.44	-0.42	-0.39	-0.39	-0.39	-0.37	-0.37	-0.34	-0.37	-0.34		
	RANKED OUTPUT? 5 16																			
VSTRNA	0.72	0.70	0.68	0.65	0.65	0.59	0.49	0.49	0.72	0.70	0.68	0.65	0.59	0.51	0.49	0.49	0.49	0.49		
	-0.28	-0.24	-0.21	-0.21	-0.21	-0.20	-0.17	-0.17	-0.28	-0.24	-0.21	-0.21	-0.21	-0.20	-0.19	-0.17	-0.19	-0.17		
VCGAC	0.48	0.45	0.44	0.44	0.44	0.41	0.41	0.41	0.48	0.45	0.44	0.44	0.44	0.41	0.41	0.41	0.41	0.41		
	-0.16	-0.16	-0.16	-0.16	-0.16	-0.16	-0.15	-0.15	-0.16	-0.16	-0.16	-0.16	-0.16	-0.15	-0.15	-0.15	-0.15	-0.15		
	RANKED OUTPUT? 6 16																			
VCGAC	0.41	0.33	0.28	0.27	0.24	0.24	0.24	0.23	0.41	0.33	0.28	0.27	0.24	0.24	0.24	0.24	0.24	0.23		
	-0.32	-0.31	-0.23	-0.19	-0.16	-0.16	-0.13	-0.12	-0.32	-0.31	-0.23	-0.19	-0.16	-0.16	-0.13	-0.12	-0.13	-0.12		
TRCGAC	0.21	0.21	0.21	0.20	0.20	0.20	0.20	0.20	0.21	0.21	0.21	0.20	0.20	0.20	0.20	0.20	0.20	0.20		
	-0.11	-0.10	-0.10	-0.10	-0.10	-0.10	-0.10	-0.09	-0.11	-0.10	-0.10	-0.10	-0.10	-0.10	-0.10	-0.10	-0.10	-0.09		
	RANKED OUTPUT? 7 16																			
TRCGAC	0.11	0.10	0.09	0.06	0.06	0.06	0.06	0.05	0.11	0.10	0.09	0.06	0.06	0.06	0.06	0.06	0.06	0.05		
	-0.15	-0.12	-0.12	-0.12	-0.12	-0.11	-0.11	-0.11	-0.15	-0.12	-0.12	-0.12	-0.11	-0.11	-0.11	-0.11	-0.11	-0.11		
TRCGAC	0.05	0.05	0.05	0.05	0.05	0.05	0.04	0.04	0.05	0.05	0.05	0.05	0.04	0.04	0.04	0.04	0.04	0.03		
	-0.10	-0.10	-0.10	-0.10	-0.10	-0.10	-0.10	-0.10	-0.10	-0.10	-0.10	-0.10	-0.10	-0.10	-0.10	-0.10	-0.10	-0.10		
	RANKED OUTPUT? 8 16																			
MEAN VALUE	-0.01	0.00	0.00	0.02	-0.01	0.02	-0.01	0.02	-0.01	0.02	-0.01	0.02	-0.01	0.02	-0.01	0.02	-0.01	0.02		
NO. OF PEAKS	0	40	104	399	273	290	122	0	0	40	104	399	273	290	122	0	0	0		
RMS	0.00	0.33	0.70	0.10	0.08	0.04	0.03	0.00	0.00	0.33	0.70	0.10	0.08	0.04	0.03	0.00	0.00	0.00		

SEAWORTHINESS TEST RESULTS IN SEA STATE 2 (29 FEB 1980)

RUN 19 P.BOW SEA, WPB, APPROX. 16 KNOTS

229W19

CHRONOLOGICAL OUTPUT?		1 16		2 16		3 16		4 16		5 16		6 16	
PITCH	1.66	2.00	1.97	2.62	2.29	1.99	2.02	2.12					
ROLL	0.49	0.52	-0.93	0.52	1.11	0.31	0.63	0.91					
PITCH	2.72	2.59	2.12	2.34	2.39	2.34	2.51	2.72					
ROLL	0.94	0.90	1.04	0.90	1.06	0.98	1.29	0.63					
CHRONOLOGICAL OUTPUT? 2 16													
ROLL	-0.15	0.73	0.93	0.59	0.88	1.42	0.24	0.20					
ROLL	-1.27	-1.61	-1.37	-1.12	-1.51	-0.78	-0.78	-1.07					
ROLL	0.49	1.17	0.63	0.59	0.63	1.76	2.00	1.51					
ROLL	-1.56	-1.95	-1.03	-1.03	-0.88	-0.88	-0.39	-0.39					
CHRONOLOGICAL OUTPUT? 3 16													
VRWAC	0.23	0.23	0.18	0.20	0.24	0.20	0.24	0.05					
VRWAC	-0.11	0.18	0.00	0.13	0.08	0.07	0.02	-0.13					
VRWAC	0.54	0.36	0.60	0.18	0.13	0.11	0.28	0.54					
VRWAC	-0.15	-0.13	-0.13	-0.29	-0.29	-0.21	0.02	-0.16					
CHRONOLOGICAL OUTPUT? 4 16													
USTRNA	0.26	0.20	0.31	0.20	0.18	0.18	0.20	0.15					
USTRNA	0.13	-0.03	0.15	0.08	0.13	0.08	0.04	0.07					
USTRNA	0.29	-0.02	-0.01	0.18	0.03	0.20	0.24	0.22					
USTRNA	0.24	-0.15	-0.16	-0.16	-0.06	-0.02	-0.09	0.14					
CHRONOLOGICAL OUTPUT? 5 16													
VCGAC	0.11	0.05	0.04	0.04	0.03	0.09	0.14	0.15					
VCGAC	-0.08	-0.04	-0.01	-0.01	-0.02	-0.02	-0.02	-0.13					
VCGAC	0.09	0.08	0.09	0.15	0.02	0.15	0.09	0.13					
VCGAC	-0.15	-0.09	-0.09	-0.10	-0.02	-0.02	-0.05	-0.06					
CHRONOLOGICAL OUTPUT? 6 16													
TRCGAC	0.04	0.05	0.04	0.07	0.04	0.07	0.04	0.05					
TRCGAC	-0.05	-0.02	-0.02	-0.04	-0.03	-0.03	-0.03	-0.03					
TRCGAC	0.06	0.04	0.06	0.03	0.06	0.07	0.04	0.06					
TRCGAC	-0.04	-0.04	-0.03	-0.05	-0.02	-0.02	-0.02	-0.03					
MEAN VALUE NO. OF PEAKS RMS													
PITCH	-0.01		175					1.06					
ROLL	0.01		102					0.66					
VRWAC	0.00		300					0.19					
USTRNA	0.00		337					0.14					
VCGAC	0.00		255					0.07					
TRCGAC	-0.00		156					0.03					

SEAWORTHINESS TEST RESULTS IN SEA STATE 2 (29 FEB 1980)

RUN 20 S. QUARTERING SEA, SES, APPROX. 16 KNOTS

229S20

CHRONOLOGICAL OUTPUT? 2 16

PITCH 0.60 0.72 0.76 1.37 0.59 1.48 0.52 0.72  
 -0.01 -0.76 -0.28 -0.78 -0.96 -0.52 -0.49 -0.75  
 PITCH 0.86 0.76 0.37 0.52 0.67 0.96 0.78 0.60  
 -0.44 -0.65 -0.98 -0.91 -0.76 -0.47 -0.67 -0.86

CHRONOLOGICAL OUTPUT? 3 16

ROLL 1.42 0.44 1.46 1.61 0.83 0.88 0.73 0.24  
 -0.73 -0.78 -1.22 -1.86 -0.78 -0.54 -1.12 -0.83  
 ROLL 1.42 0.83 0.49 0.98 0.59 0.54 1.03 1.42  
 -0.88 -0.73 -0.49 -0.54 -0.44 -0.59 -1.37 -0.83

CHRONOLOGICAL OUTPUT? 4 16

VRWAC 0.05 0.05 0.07 0.05 0.05 0.05 0.07 0.05 0.07  
 -0.05 -0.05 -0.05 -0.05 -0.08 -0.05 -0.05 -0.05  
 VRWAC 0.05 0.05 0.05 0.05 0.05 0.05 0.05 0.07  
 -0.05 -0.05 -0.05 -0.05 -0.05 -0.05 -0.07 -0.05

CHRONOLOGICAL OUTPUT? 5 7

VSTRNA 0.05 0.06 0.05 0.05 0.05 0.05 0.06 0.06  
 -0.05 -0.05 -0.06 -0.06 -0.06 -0.05 -0.05 -0.04

CHRONOLOGICAL OUTPUT? 6 2

VCGAC 0.05 0.06  
 -0.05 -0.05

CHRONOLOGICAL OUTPUT? 7 16

TRCGAC 0.96 0.03 0.07 0.05 0.03 0.03 0.03 0.05  
 -0.02 -0.04 -0.05 -0.06 -0.03 -0.02 -0.03 -0.03  
 TRCGAC 0.03 0.09 0.09 0.05 0.04 0.03 0.04 0.05  
 -0.04 -0.02 -0.01 -0.03 -0.04 -0.04 -0.04 -0.02

MEAN VALUE	NO. OF PEAKS	RMS
NAVENT	0	0.00
PITCH	16	0.41
ROLL	107	0.42
VRWAC	135	0.02
VSTRNA	7	0.02
VCGAC	2	0.01
TRCGAC	107	0.02
LMCGAC	0	0.00

AVERAGE TR PK TR PK TR PK TR PK TR PK TR PK TR PK TR PK  
 PK 0.77 -0.69 1.09 -0.90 1.48 -0.98 1.48 -0.98 1.48 -0.98 1.48 -0.98 1.48 -0.98 1.48 -0.98  
 TR 0.96 -0.88 1.48 -1.36 1.82 -1.72 1.82 -1.72 1.82 -1.72 1.82 -1.72 1.82 -1.72 1.82 -1.72  
 PK 0.06 -0.05 0.07 -0.06 0.07 -0.06 0.07 -0.06 0.07 -0.06 0.07 -0.06 0.07 -0.06 0.07 -0.06  
 TR 0.05 -0.05 0.06 -0.06 0.06 -0.06 0.06 -0.06 0.06 -0.06 0.06 -0.06 0.06 -0.06 0.06 -0.06  
 PK 0.05 -0.05 0.06 -0.06 0.06 -0.06 0.06 -0.06 0.06 -0.06 0.06 -0.06 0.06 -0.06 0.06 -0.06  
 TR 0.04 -0.04 0.07 -0.05 0.10 -0.06 0.10 -0.06 0.10 -0.06 0.10 -0.06 0.10 -0.06 0.10 -0.06

RANKED OUTPUT? 2 16

PITCH 1.48 1.37 0.96 0.86 0.78 0.76 0.76 0.76 0.72  
 -0.98 -0.96 -0.91 -0.86 -0.81 -0.78 -0.76 -0.76 -0.76  
 PITCH 0.72 0.67 0.60 0.60 0.59 0.52 0.52 0.52 0.37  
 -0.75 -0.67 -0.65 -0.52 -0.49 -0.47 -0.44 -0.44 -0.28

RANKED OUTPUT? 3 16

ROLL 2.59 2.15 1.95 1.86 1.81 1.61 1.61 1.61 1.56  
 -2.00 -1.86 -1.86 -1.81 -1.76 -1.76 -1.71 -1.71 -1.56  
 ROLL 1.56 1.51 1.51 1.51 1.51 1.46 1.46 1.46 1.46  
 -1.46 -1.46 -1.42 -1.37 -1.32 -1.32 -1.32 -1.32 -1.32

RANKED OUTPUT? 4 16

VRWAC 0.05 0.08 0.08 0.08 0.08 0.08 0.08 0.08 0.07  
 -0.10 -0.08 -0.08 -0.08 -0.08 -0.08 -0.08 -0.08 -0.08  
 VRWAC 0.07 0.07 0.07 0.07 0.07 0.07 0.07 0.07 0.07  
 -0.07 -0.07 -0.07 -0.07 -0.07 -0.07 -0.07 -0.07 -0.07

RANKED OUTPUT? 5 7

VSTRNA 0.06 0.06 0.06 0.06 0.05 0.05 0.05 0.05 0.05  
 -0.06 -0.06 -0.05 -0.05 -0.05 -0.05 -0.05 -0.05 -0.04

RANKED OUTPUT? 6 2

VCGAC 0.06 0.05  
 -0.05 -0.05

RANKED OUTPUT? 7 16

TRCGAC 0.15 0.14 0.10 0.10 0.10 0.09 0.09 0.09 0.09  
 -0.09 -0.06 -0.06 -0.06 -0.06 -0.06 -0.06 -0.06 -0.05  
 TRCGAC 0.08 0.08 0.07 0.07 0.07 0.07 0.07 0.07 0.06  
 -0.05 -0.05 -0.05 -0.05 -0.05 -0.05 -0.05 -0.05 -0.05

SEAWORTHINESS TEST RESULTS IN SEA STATE 2 (29 FEB 1980)

229W20

RUN 20 S.QUARTERING SEA, WPB, APPROX. 16 KNOTS

	AVERAGE		AVE 1/3		AVE 1/10		EXTREME	
	FK	TR	FK	TR	FK	TR	FK	TR
PITCH	0.71	-0.82	1.17	-1.53	1.31	-1.80	1.37	-1.84
ROLL	2.27	-2.58	4.76	-4.84	5.77	-6.35	6.69	-7.57
VRMACH	0.08	-0.04	0.22	-0.13	0.28	-0.14	0.41	-0.20
VSTRNA	0.04	-0.04	0.10	-0.08	0.15	-0.10	0.26	-0.12
VCGAC	0.05	-0.02	0.06	-0.03	0.07	-0.04	0.08	-0.06
TRCGAC	0.07	-0.07	0.11	-0.12	0.14	-0.14	0.15	-0.15

	RANKED OUTPUT#		RMS	
	1	16	32	84
PITCH	1.37	1.32	1.25	1.22
ROLL	6.69	6.59	5.96	5.52
VRMACH	0.98	0.96	0.93	0.90
VSTRNA	0.98	0.96	0.93	0.90
VCGAC	0.98	0.96	0.93	0.90
TRCGAC	0.98	0.96	0.93	0.90

	RANKED OUTPUT#		RMS	
	2	16	32	84
PITCH	1.37	1.32	1.25	1.22
ROLL	6.69	6.59	5.96	5.52
VRMACH	0.98	0.96	0.93	0.90
VSTRNA	0.98	0.96	0.93	0.90
VCGAC	0.98	0.96	0.93	0.90
TRCGAC	0.98	0.96	0.93	0.90

	RANKED OUTPUT#		RMS	
	3	16	32	84
PITCH	1.37	1.32	1.25	1.22
ROLL	6.69	6.59	5.96	5.52
VRMACH	0.98	0.96	0.93	0.90
VSTRNA	0.98	0.96	0.93	0.90
VCGAC	0.98	0.96	0.93	0.90
TRCGAC	0.98	0.96	0.93	0.90

	RANKED OUTPUT#		RMS	
	4	16	32	84
PITCH	1.37	1.32	1.25	1.22
ROLL	6.69	6.59	5.96	5.52
VRMACH	0.98	0.96	0.93	0.90
VSTRNA	0.98	0.96	0.93	0.90
VCGAC	0.98	0.96	0.93	0.90
TRCGAC	0.98	0.96	0.93	0.90

	RANKED OUTPUT#		RMS	
	5	16	32	84
PITCH	1.37	1.32	1.25	1.22
ROLL	6.69	6.59	5.96	5.52
VRMACH	0.98	0.96	0.93	0.90
VSTRNA	0.98	0.96	0.93	0.90
VCGAC	0.98	0.96	0.93	0.90
TRCGAC	0.98	0.96	0.93	0.90

	RANKED OUTPUT#		RMS	
	6	16	32	84
PITCH	1.37	1.32	1.25	1.22
ROLL	6.69	6.59	5.96	5.52
VRMACH	0.98	0.96	0.93	0.90
VSTRNA	0.98	0.96	0.93	0.90
VCGAC	0.98	0.96	0.93	0.90
TRCGAC	0.98	0.96	0.93	0.90

SEAWORTHINESS TEST RESULTS IN LOW SEA STATE 3 (27 FEB 1980)

RUN 1 HEAD SEA, SES, APPROX. 27 KNOTS

227S01

	CHRONOLOGICAL OUTPUT		AVERAGE		AVE 1/3		AVE 1/10		EXTREME	
	PK	TR	PK	TR	PK	TR	PK	TR	PK	TR
PITCH	1.95	1.40	1.60	2.02	1.84	1.69	1.60	1.53	1.43	1.40
ROLL	-0.07	0.39	0.21	0.34	-0.33	0.23	-0.81	-0.90	3.03	-3.27
PITCH	-0.07	1.17	1.53	1.27	1.42	0.85	0.75	0.52	1.09	-0.81
ROLL	-1.17	-1.38	0.15	-0.10	0.02	-0.42	-1.77	-0.62	0.74	-0.51
CHRONOLOGICAL OUTPUT 3 16										
ROLL	1.46	0.83	2.03	1.81	1.27	2.00	0.83	1.17	1.43	1.40
ROLL	-1.27	-0.68	-1.07	-0.98	-1.46	-0.59	-0.68	-1.07	-1.42	-1.38
ROLL	0.63	1.42	0.15	0.00	0.44	0.73	1.32	1.12	1.03	0.99
ROLL	-1.17	-1.81	-0.98	-1.42	-1.37	-2.29	-2.29	-0.39	-1.17	-1.17
CHRONOLOGICAL OUTPUT 4 16										
VBQWAC	0.11	0.60	0.46	0.28	0.46	0.28	0.36	0.42	2.00	1.90
VBQWAC	-0.37	-0.49	-0.23	-0.33	-0.24	-0.23	-0.24	-0.23	-2.29	-2.15
VBQWAC	0.36	0.57	0.46	0.46	0.63	0.75	0.55	0.39	1.61	1.61
VBQWAC	-0.26	-0.21	-0.54	-0.18	-0.29	-0.44	-0.31	-0.33	-1.71	-1.66
CHRONOLOGICAL OUTPUT 5 16										
VSTRNA	0.34	0.33	0.45	0.37	0.40	0.40	0.31	0.32	0.94	0.88
VSTRNA	-0.22	-0.20	-0.21	-0.28	-0.20	-0.26	-0.20	-0.40	-0.67	-0.67
VSTRNA	0.39	0.41	0.38	0.30	0.39	0.34	0.37	0.36	0.83	0.81
VSTRNA	-0.28	-0.21	-0.24	-0.31	-0.26	-0.18	-0.20	-0.28	-0.60	-0.60
CHRONOLOGICAL OUTPUT 6 16										
VCGAC	0.48	0.41	0.33	0.49	0.38	0.50	0.49	0.44	0.64	0.63
VCGAC	-0.27	-0.21	-0.33	-0.18	-0.43	-0.19	-0.33	-0.30	-0.42	-0.41
VCGAC	0.32	0.51	0.31	0.33	0.33	0.36	0.55	0.60	0.55	0.52
VCGAC	-0.31	-0.19	-0.24	-0.24	-0.18	-0.24	-0.47	-0.23	-0.38	-0.37
CHRONOLOGICAL OUTPUT 7 16										
TRCGAC	0.08	0.03	0.04	0.08	0.03	0.03	0.03	0.06	0.75	0.75
TRCGAC	-0.08	-0.08	-0.06	-0.10	-0.10	-0.09	-0.08	-0.09	-0.50	-0.49
TRCGAC	0.03	0.03	0.05	0.02	0.02	0.05	0.04	0.04	0.65	0.62
TRCGAC	-0.07	-0.07	-0.08	-0.08	-0.09	-0.09	-0.08	-0.09	-0.46	-0.46
MEAN VALUE NO. OF PEAKS RMS										
MAWENT	0.01	0	0.00	0.00	0.00	0.00	0.00	0.00	0.07	0.06
PITCH	-0.05	47	0.68	0.68	0.68	0.68	0.68	0.68	0.07	0.07
ROLL	-0.05	104	0.87	0.87	0.87	0.87	0.87	0.87	-0.10	-0.10
VBQWAC	0.03	309	0.25	0.25	0.25	0.25	0.25	0.25	0.03	0.05
VSTRNA	0.03	191	0.15	0.15	0.15	0.15	0.15	0.15	0.03	0.05
VCGAC	0.04	264	0.04	0.04	0.04	0.04	0.04	0.04	-0.09	-0.09
TRCGAC	-0.02	55	0.63	0.63	0.63	0.63	0.63	0.63	-0.09	-0.09
LINEGAC	-0.06	0	0.00	0.00	0.00	0.00	0.00	0.00	0.00	0.00

SEAWORTHINESS TEST RESULTS IN LOW SEA STATE 3 (27 FEB 1980)

227S02

RUN 2 FOLLOWING SEA, SES; APPROX. 29 KNOTS

	CHRONOLOGICAL OUTPUT?		AVERAGE		AVE 1/3		AVE 1/10		EXTREME	
	PK	TR	PK	TR	PK	TR	PK	TR	PK	TR
PITCH	0.67	1.11	0.68	1.12	2.16	1.05	1.61	0.42	0.67	1.11
PITCH	-1.22	-0.72	-2.56	-1.37	-1.95	-1.70	-0.88	-1.74	-1.22	-0.72
PITCH	0.31	0.28	0.26	2.05	0.86	1.68	1.98	0.93	0.31	0.28
PITCH	-1.22	-1.20	-0.85	-2.21	-1.25	-1.31	-0.75	-1.25	-1.22	-1.20
CHRONOLOGICAL OUTPUT? 2 16										
ROLL	1.12	1.07	0.98	0.44	3.08	1.65	0.98	3.17	1.12	1.07
ROLL	-1.86	-1.27	-1.66	-1.71	-2.83	-1.37	-0.39	-1.61	-1.86	-1.27
ROLL	1.46	2.39	0.88	1.76	0.73	2.54	-0.39	1.71	1.46	2.39
ROLL	-0.34	0.24	-0.54	-1.42	-3.03	-2.83	-1.90	-1.37	-0.34	0.24
CHRONOLOGICAL OUTPUT? 3 16										
VBOWAC	0.33	0.36	0.29	0.33	0.36	0.42	0.36	0.28	0.33	0.36
VBOWAC	-0.20	-0.21	-0.28	-0.41	-0.54	-0.21	-0.33	-0.31	-0.20	-0.21
VBOWAC	0.28	0.28	0.39	0.29	0.28	0.29	0.26	0.31	0.28	0.28
VBOWAC	-0.23	-0.26	-0.23	-0.24	-0.33	-0.54	-0.23	-0.26	-0.23	-0.26
CHRONOLOGICAL OUTPUT? 4 16										
VSTRNA	0.39	0.49	0.34	0.28	0.28	0.36	0.39	0.32	0.39	0.49
VSTRNA	-0.27	-0.28	-0.39	-0.33	-0.26	-0.24	-0.24	-0.22	-0.27	-0.28
VSTRNA	0.28	0.34	0.35	0.29	0.28	0.27	0.55	0.52	0.28	0.34
VSTRNA	-0.24	-0.23	-0.20	-0.21	-0.20	-0.20	-0.20	-0.37	-0.24	-0.23
CHRONOLOGICAL OUTPUT? 5 16										
VCGAC	0.33	0.28	0.46	0.35	0.33	0.33	0.30	0.24	0.33	0.28
VCGAC	-0.32	-0.26	-0.32	-0.19	-0.20	-0.26	-0.20	-0.27	-0.32	-0.26
VCGAC	0.33	0.31	0.42	0.27	0.33	0.27	0.27	0.37	0.33	0.31
VCGAC	-0.28	-0.29	-0.22	-0.24	-0.24	-0.26	-0.25	-0.23	-0.28	-0.29
CHRONOLOGICAL OUTPUT? 6 16										
TRCGAC	0.03	0.04	0.02	0.04	0.03	0.05	0.03	0.05	0.03	0.04
TRCGAC	-0.09	-0.08	-0.11	-0.11	-0.10	-0.09	-0.09	-0.07	-0.09	-0.08
TRCGAC	0.06	0.02	0.04	0.02	0.04	0.03	0.03	0.03	0.06	0.02
TRCGAC	-0.09	-0.09	-0.10	-0.10	-0.08	-0.08	-0.08	-0.10	-0.09	-0.09
CHRONOLOGICAL OUTPUT? 7 16										
WAVENT	0.02	0.00	0	0	0.00	0.00	0.00	0.00	0.02	0.00
PITCH	-0.06	0.91	103	103	0.91	0.91	1.07	1.07	-0.06	0.91
ROLL	-0.03	1.07	92	92	1.07	1.07	0.08	0.08	-0.03	1.07
VBOWAC	0.03	0.12	10	10	0.12	0.12	0.09	0.09	0.03	0.12
VSTRNA	0.03	0.08	20	20	0.08	0.08	0.03	0.03	0.03	0.08
VCGAC	0.04	0.09	20	20	0.09	0.09	0.03	0.03	0.04	0.09
TRCGAC	-0.03	0.03	0	0	0.03	0.03	0.00	0.00	-0.03	0.03
LNCGAC	-0.07	0.00	0	0	0.00	0.00	0.00	0.00	-0.07	0.00

SEAWORTHINESS TEST RESULTS IN LOW SEA STATE 3 (27 FEB 1980)

RUN 3 P. BEAM SEA, SES, APPROX. 28 KNOTS

227503

CHRONOLOGICAL OUTPUT?	AVERAGE		AVE 1/3		AVE 1/10		EXTREME	
	PK	TR	PK	TR	PK	TR		
PITCH	1.20	2.93	1.06	2.20	2.26	1.53	1.79	2.29
ROLL	-1.01	-0.28	-0.05	-1.58	-1.64	-1.61	-1.03	0.73
VBOWAC	0.32	-0.25	0.39	-0.31	0.45	-0.35	0.62	-0.44
VSTRNA	0.32	-0.23	0.34	-0.26	0.37	-0.29	0.37	-0.29
VCGAC	0.34	-0.21	0.40	-0.25	0.44	-0.30	0.46	-0.32
TRCGAC	0.05	-0.09	0.07	-0.11	0.11	-0.12	0.20	-0.13

CHRONOLOGICAL OUTPUT? 2 16

PITCH	2.93	2.31	2.29	2.28	2.28	2.25	2.20	2.13
ROLL	-3.24	-2.47	-2.46	-2.31	-2.31	-2.28	-2.18	-2.16

CHRONOLOGICAL OUTPUT? 3 16

PITCH	1.99	1.99	1.95	1.90	1.89	1.87	1.79	1.79
ROLL	-2.13	-2.07	-2.00	-1.99	-1.97	-1.95	-1.95	-1.94

CHRONOLOGICAL OUTPUT? 4 16

PITCH	3.52	3.08	2.69	2.64	2.64	2.64	2.59	2.54
ROLL	-3.96	-3.66	-3.08	-2.83	-2.54	-2.44	-2.44	-2.39
VBOWAC	0.31	0.28	0.31	0.29	0.29	0.33	0.33	0.33
VSTRNA	0.31	0.28	0.31	0.33	0.29	0.29	0.33	0.33
VCGAC	0.31	0.28	0.31	0.33	0.29	0.29	0.33	0.33
TRCGAC	0.02	-0.24	-0.24	-0.24	-0.24	-0.24	-0.31	-0.31

CHRONOLOGICAL OUTPUT? 5 16

PITCH	0.29	0.29	0.29	0.34	0.33	0.34	0.33	0.32
ROLL	-0.23	-0.29	-0.24	-0.24	-0.20	-0.22	-0.22	-0.20
VBOWAC	0.29	0.34	0.31	0.33	0.34	0.37	0.31	0.32
VSTRNA	0.29	0.34	0.31	0.33	0.34	0.37	0.31	0.32
VCGAC	0.29	0.34	0.31	0.33	0.34	0.37	0.31	0.32
TRCGAC	-0.22	-0.23	-0.26	-0.24	-0.25	-0.24	-0.24	-0.24

CHRONOLOGICAL OUTPUT? 6 16

PITCH	0.39	0.32	0.36	0.34	0.46	0.32	0.40	0.39
ROLL	-0.20	-0.24	-0.20	-0.21	-0.28	-0.21	-0.22	-0.17
VBOWAC	0.30	0.31	0.28	0.38	0.42	0.33	0.36	0.32
VSTRNA	0.30	0.31	0.28	0.38	0.42	0.33	0.36	0.32
VCGAC	0.30	0.31	0.28	0.38	0.42	0.33	0.36	0.32
TRCGAC	-0.20	-0.20	-0.21	-0.21	-0.17	-0.32	-0.21	-0.19

CHRONOLOGICAL OUTPUT? 7 16

PITCH	0.04	0.03	0.03	0.06	0.10	0.04	0.02	0.04
ROLL	-0.07	-0.10	-0.11	-0.08	-0.12	-0.09	-0.08	-0.08
VBOWAC	0.06	0.04	0.02	0.04	0.04	0.03	0.02	0.04
VSTRNA	0.06	0.04	0.02	0.04	0.04	0.03	0.02	0.04
VCGAC	0.06	0.04	0.02	0.04	0.04	0.03	0.02	0.04
TRCGAC	-0.09	-0.07	-0.13	-0.10	-0.07	-0.11	-0.08	-0.11

WAVEHT	MEAN VALUE	NO. OF PEAKS	RMS
PITCH	0.03	0	0.00
ROLL	0.04	77	0.95
VBOWAC	-0.04	94	1.07
VSTRNA	0.03	107	0.12
VCGAC	0.03	19	0.09
TRCGAC	0.04	26	0.04
LMCGAC	-0.02	44	0.03
	-0.07	0	0.00

SEAWORTHINESS TEST RESULTS IN LOW SEA STATE 3 (27 FEB 1980)

RUN 4 S. BEAM SEA, SES, APPROX. 29 KNOTS

227S04

CHRONOLOGICAL OUTPUT?	AVERAGE			AVE 1/3			AVE 1/10			EXTREME		
	PK	TR	TR	PK	TR	TR	PK	TR	TR	PK	TR	TR
RANKED OUTPUT? 2 16												
PITCH	1.04	-1.06	1.55	1.55	-1.65	2.00	1.94	1.87	1.76	2.95	-2.77	1.73
ROLL	1.28	-1.32	2.03	2.03	-2.05	-2.10	2.55	-2.59	3.91	-3.42	-2.77	1.73
VROMAC	0.41	-0.35	0.55	0.55	-0.50	0.69	0.69	-0.62	0.90	-0.83	0.90	0.83
VSTRNA	0.34	-0.26	0.42	0.42	-0.38	0.49	0.49	-0.38	0.58	-0.50	0.58	0.52
VCGAC	0.38	-0.29	0.49	0.49	-0.38	0.58	0.58	-0.44	0.72	-0.52	0.72	0.52
TRCGAC	0.03	-0.11	0.04	0.04	-0.12	0.06	0.06	-0.14	0.09	-0.09	0.09	0.15
RANKED OUTPUT? 2 16												
PITCH	2.95	2.33	2.02	2.02	2.00	1.94	1.87	1.76	2.95	-2.77	1.73	1.73
ROLL	-2.77	-2.60	-2.52	-2.52	-2.23	-2.10	-2.08	-2.05	-1.86	-2.77	1.73	1.73
VROMAC	1.68	1.68	1.64	1.64	1.60	1.53	1.51	1.48	1.48	1.68	1.48	1.48
VSTRNA	-1.82	-1.77	-1.73	-1.73	-1.69	-1.69	-1.68	-1.58	-1.53	-1.82	1.48	1.48
RANKED OUTPUT? 3 16												
PITCH	3.91	3.03	2.64	2.64	2.64	2.59	2.54	2.34	2.34	3.91	2.34	2.34
ROLL	-3.42	-2.73	-2.69	-2.64	-2.64	-2.64	-2.64	-2.54	-2.49	-3.42	2.34	2.34
VROMAC	2.20	2.15	2.15	2.10	2.10	2.10	2.10	2.10	2.10	2.20	2.10	2.05
VSTRNA	-2.44	-2.34	-2.29	-2.25	-2.25	-2.25	-2.15	-2.15	-2.15	-2.44	2.10	2.05
RANKED OUTPUT? 4 16												
VROMAC	0.90	0.88	0.88	0.85	0.85	0.81	0.91	0.78	0.78	0.90	0.78	0.78
VSTRNA	-0.83	-0.76	-0.70	-0.68	-0.65	-0.65	-0.65	-0.65	-0.63	-0.83	0.78	0.78
VCGAC	0.72	0.68	0.68	0.65	0.65	0.65	0.63	0.63	0.63	0.72	0.63	0.62
TRCGAC	-0.63	-0.62	-0.62	-0.62	-0.60	-0.60	-0.60	-0.59	-0.59	-0.63	0.63	0.62
RANKED OUTPUT? 5 16												
VSTRNA	0.58	0.55	0.51	0.50	0.50	0.45	0.44	0.43	0.43	0.58	0.43	0.43
VCGAC	-0.50	-0.39	-0.37	-0.36	-0.36	-0.36	-0.35	-0.34	-0.34	-0.50	0.43	0.43
VSTRNA	0.42	0.41	0.41	0.40	0.40	0.40	0.40	0.40	0.40	0.42	0.40	0.39
VCGAC	-0.33	-0.33	-0.33	-0.33	-0.33	-0.33	-0.33	-0.33	-0.32	-0.33	0.40	0.39
RANKED OUTPUT? 6 16												
VCGAC	0.72	0.65	0.64	0.63	0.63	0.63	0.62	0.58	0.53	0.72	0.58	0.53
VSTRNA	-0.52	-0.48	-0.47	-0.47	-0.44	-0.44	-0.44	-0.44	-0.43	-0.52	0.58	0.53
VCGAC	0.53	0.51	0.51	0.50	0.50	0.50	0.49	0.49	0.49	0.53	0.49	0.49
TRCGAC	-0.42	-0.42	-0.42	-0.40	-0.40	-0.40	-0.39	-0.39	-0.38	-0.42	0.49	0.49
RANKED OUTPUT? 7 16												
TRCGAC	0.09	0.07	0.07	0.06	0.06	0.05	0.05	0.05	0.05	0.09	0.05	0.05
VROMAC	-0.15	-0.14	-0.14	-0.14	-0.14	-0.14	-0.13	-0.13	-0.13	-0.15	0.05	0.05
VSTRNA	0.04	0.04	0.04	0.04	0.04	0.04	0.04	0.04	0.04	0.04	0.04	0.04
VCGAC	-0.13	-0.13	-0.12	-0.12	-0.12	-0.12	-0.12	-0.12	-0.12	-0.13	0.04	0.04
TRCGAC	-0.07	-0.07	-0.07	-0.07	-0.07	-0.07	-0.07	-0.07	-0.07	-0.07	-0.07	-0.12

SEAWORTHINESS TEST RESULTS IN LOW SEA STATE 3 (27 FEB 1980)

227S05

RUN 5 P. BOW SEA, SES, APPROX. 31 KNOTS

	CHRONOLOGICAL OUTPUT? 2 16				AVERAGE				AVE 1/10				EXTREME			
	PK	TR	PK	TR	PK	TR	PK	TR	PK	TR	PK	TR	PK	TR	PK	TR
PITCH	0.76	0.59	1.56	2.16	0.76	0.50	1.09	0.99	0.96	-0.80	1.45	-1.40	1.80	-1.82	2.16	-2.15
ROLL	-0.39	-0.60	-1.11	0.37	-0.72	-0.59	-0.73	-0.62	1.67	-1.74	2.96	-3.09	3.90	-3.97	4.79	-4.64
VBOUAC	0.38	-0.29	0.42	0.78	0.83	1.58	1.12	1.33	0.35	-0.25	0.42	-0.31	0.47	-0.37	0.49	-0.44
VSTRNA	0.83	1.45	0.78	0.83	1.58	1.12	1.33	-0.07	0.37	-0.26	0.45	-0.33	0.52	-0.38	0.62	-0.45
TRCGAC	-0.33	-0.52	-0.57	-0.28	-0.24	0.07	-1.12	-2.15	0.04	-0.10	0.06	-0.13	0.07	-0.15	0.07	-0.18

	RANKED OUTPUT? 2 16							
PITCH	2.16	1.66	1.58	1.56	1.45	1.38	1.35	1.33
ROLL	-2.15	-1.79	-1.53	-1.51	-1.40	-1.38	-1.29	-1.25
PITCH	1.32	1.25	1.24	1.12	1.09	1.09	1.09	0.99
ROLL	-1.22	-1.12	-1.11	-1.03	-0.96	-0.96	-0.91	-0.90

	RANKED OUTPUT? 3 16							
ROLL	4.79	4.39	4.15	4.10	4.00	3.91	3.91	3.61
ROLL	-4.64	-4.39	-4.39	-4.05	-4.00	-3.96	-3.76	-3.66
ROLL	3.56	3.27	3.22	3.22	3.08	2.93	2.93	2.88
ROLL	-3.66	-3.56	-3.56	-3.32	-3.12	-3.12	-3.03	-2.98

	RANKED OUTPUT? 4 16							
VBOUAC	0.78	0.68	0.62	0.62	0.62	0.62	0.62	0.62
VBOUAC	-0.65	-0.59	-0.55	-0.52	-0.52	-0.52	-0.52	-0.52
VBOUAC	0.60	0.60	0.60	0.59	0.59	0.59	0.57	0.57
VBOUAC	-0.50	-0.50	-0.50	-0.50	-0.49	-0.47	-0.47	-0.46

	RANKED OUTPUT? 5 16							
VSTRNA	0.49	0.49	0.47	0.49	0.47	0.46	0.46	0.45
VSTRNA	-0.44	-0.42	-0.42	-0.40	-0.40	-0.34	-0.33	-0.33
VSTRNA	0.45	0.45	0.45	0.44	0.44	0.42	0.42	0.42
VSTRNA	-0.33	-0.33	-0.32	-0.32	-0.32	-0.32	-0.32	-0.32

	RANKED OUTPUT? 6 16							
VCGAC	0.62	0.59	0.56	0.55	0.54	0.52	0.52	0.52
VCGAC	-0.45	-0.43	-0.42	-0.42	-0.42	-0.41	-0.37	-0.37
VCGAC	0.51	0.50	0.50	0.50	0.49	0.49	0.48	0.47
VCGAC	-0.37	-0.37	-0.37	-0.36	-0.36	-0.35	-0.34	-0.34

	RANKED OUTPUT? 7 16							
TRCGAC	0.07	0.07	0.07	0.07	0.06	0.06	0.06	0.06
TRCGAC	-0.16	-0.16	-0.14	-0.14	-0.14	-0.14	-0.13	-0.13
TRCGAC	0.06	0.06	0.05	0.05	0.05	0.05	0.05	0.05
TRCGAC	-0.13	-0.12	-0.12	-0.12	-0.12	-0.12	-0.12	-0.12

	CHRONOLOGICAL OUTPUT? 2 16							
PITCH	0.76	0.59	1.56	2.16	0.76	0.50	1.09	0.99
ROLL	-0.39	-0.60	-1.11	0.37	-0.72	-0.59	-0.73	-0.62
VBOUAC	0.38	-0.29	0.42	0.78	0.83	1.58	1.12	1.33
VSTRNA	0.83	1.45	0.78	0.83	1.58	1.12	1.33	-0.07
TRCGAC	-0.33	-0.52	-0.57	-0.28	-0.24	0.07	-1.12	-2.15

	CHRONOLOGICAL OUTPUT? 3 16							
ROLL	0.63	0.73	0.15	-0.24	1.46	0.05	1.12	1.27
ROLL	-2.34	-0.34	-1.22	-2.88	-2.78	-4.00	-3.66	-0.15
ROLL	1.61	-0.49	3.56	0.88	-0.24	1.76	2.39	2.29
ROLL	-1.81	-2.34	-2.83	-2.05	-1.56	-2.83	-0.68	-1.51

	CHRONOLOGICAL OUTPUT? 4 16							
VBOUAC	0.50	0.41	0.39	0.78	0.37	0.33	0.26	0.33
VBOUAC	-0.31	-0.42	-0.20	-0.29	-0.52	-0.23	-0.28	-0.24
VBOUAC	0.34	0.37	0.42	0.33	0.31	0.33	0.47	0.28
VBOUAC	-0.11	-0.33	-0.21	-0.26	-0.29	-0.26	-0.31	-0.26

	CHRONOLOGICAL OUTPUT? 5 16							
VSTRNA	0.36	0.33	0.29	0.29	0.32	0.33	0.24	0.42
VSTRNA	-0.33	-0.24	-0.21	-0.30	-0.23	-0.22	-0.29	-0.26
VSTRNA	0.42	0.29	0.33	0.39	0.29	0.31	0.45	0.29
VSTRNA	-0.28	-0.21	-0.26	-0.22	-0.23	-0.20	-0.24	-0.25

	CHRONOLOGICAL OUTPUT? 6 16							
VCGAC	0.33	0.42	0.62	0.49	0.34	0.33	0.39	0.29
VCGAC	-0.22	-0.30	-0.26	-0.33	-0.19	-0.23	-0.20	-0.23
VCGAC	0.39	0.44	0.41	0.45	0.42	0.31	0.38	0.45
VCGAC	-0.20	-0.17	-0.23	-0.34	-0.20	-0.19	-0.28	-0.25

	CHRONOLOGICAL OUTPUT? 7 16							
TRCGAC	-0.02	0.04	0.04	0.03	0.04	0.05	0.04	0.05
TRCGAC	-0.16	-0.12	-0.10	-0.12	-0.07	-0.08	-0.09	-0.10
TRCGAC	0.04	0.00	0.03	0.02	0.06	0.05	0.04	0.03
TRCGAC	-0.07	-0.11	-0.13	-0.10	-0.08	-0.13	-0.08	-0.07

	MEAN VALUE	NO. OF PEAKS	RMS
WAVEHT	0.04	0	0.00
PITCH	0.10	36	0.65
ROLL	-0.03	117	1.54
VBOUAC	0.04	367	0.18
VSTRNA	0.03	119	0.12
VCGAC	0.04	198	0.04
TRCGAC	-0.03	67	0.04
LNCGAC	-0.08	0	0.00

SEAWORTHINESS TEST RESULTS IN LOW SEA STATE 3 (27 FEB 1980)

RUN 6 S. QUARTERING SEA, SES, APPROX. 31 KNOTS

227506

CHRONOLOGICAL OUTPUT?		2 16		AVERAGE		AVE 1/3		AVE 1/10		EXTREME	
		PK	TR	PK	TR	PK	TR	PK	TR	PK	TR
PITCH	0.96 0.96 0.81 1.12 1.09 0.68 0.44 0.72	0.97	-1.07	1.42	-1.57	1.79	-1.85	2.00	-2.07	2.00	-2.07
	-0.44 -0.65 -0.91 -1.03 -0.80 -1.09 -0.60 -0.85	1.74	-2.23	2.65	-3.42	3.52	-4.31	4.44	-5.42	4.44	-5.42
PITCH	1.01 0.67 0.96 1.30 1.48 1.81 0.99 1.76	0.56	-0.51	0.46	-0.43	0.54	-0.53	0.75	-0.65	0.75	-0.65
	-0.36 -0.78 -1.16 -1.09 -1.65 -1.68 -1.73 -0.94	0.33	-0.31	0.39	-0.31	0.45	-0.39	0.46	-0.46	0.46	-0.46
		0.33	-0.26	0.39	-0.33	0.45	-0.36	0.52	-0.38	0.52	-0.38
		0.05	-0.12	0.08	-0.16	0.12	-0.18	0.16	-0.19	0.16	-0.19
RANKED OUTPUT? 2 16											
PITCH	2.00 1.92 1.92 1.86 1.81 1.79 1.76 1.74	2.00	1.92	1.92	1.86	1.81	1.79	1.76	1.74	1.76	1.74
	-2.07 -1.94 -1.94 -1.90 -1.90 -1.87 -1.76 -1.73	-2.07	-1.94	-1.94	-1.90	-1.90	-1.87	-1.76	-1.73	-1.76	-1.73
PITCH	1.56 1.55 1.53 1.51 1.48 1.46 1.43 1.43	1.56	1.55	1.53	1.51	1.48	1.46	1.46	1.43	1.46	1.43
	-1.69 -1.69 -1.68 -1.66 -1.66 -1.64 -1.63 -1.60	-1.69	-1.69	-1.68	-1.66	-1.66	-1.64	-1.63	-1.60	-1.63	-1.60
RANKED OUTPUT? 3 16											
ROLL	4.44 3.96 3.96 3.91 3.52 3.52 3.32 3.27	4.44	3.96	3.96	3.91	3.52	3.52	3.32	3.27	3.32	3.27
	-5.42 -4.88 -4.64 -4.59 -4.59 -4.49 -4.10 -4.10	-5.42	-4.88	-4.64	-4.59	-4.59	-4.49	-4.10	-4.10	-4.10	-4.10
ROLL	3.27 3.22 3.17 3.12 3.12 3.03 3.03 3.03	3.27	3.22	3.17	3.12	3.12	3.03	3.03	3.03	3.03	3.03
	-4.05 -3.96 -3.91 -3.71 -3.61 -3.52 -3.52 -3.47	-4.05	-3.96	-3.91	-3.71	-3.61	-3.52	-3.52	-3.47	-3.52	-3.47
RANKED OUTPUT? 4 16											
VBOWAC	0.75 0.62 0.60 0.57 0.55 0.55 0.55 0.52	0.75	0.62	0.60	0.57	0.55	0.55	0.55	0.52	0.55	0.52
	-0.65 -0.60 -0.59 -0.57 -0.55 -0.55 -0.55 -0.54	-0.65	-0.60	-0.59	-0.57	-0.55	-0.55	-0.55	-0.54	-0.55	-0.54
VBOWAC	0.52 0.52 0.52 0.50 0.50 0.50 0.49 0.49	0.52	0.52	0.52	0.50	0.50	0.50	0.49	0.49	0.49	0.49
	-0.54 -0.54 -0.52 -0.49 -0.49 -0.49 -0.47 -0.47	-0.54	-0.54	-0.52	-0.49	-0.49	-0.49	-0.47	-0.47	-0.47	-0.47
RANKED OUTPUT? 5 16											
VSTRNA	0.46 0.46 0.45 0.43 0.41 0.39 0.39 0.37	0.46	0.46	0.45	0.43	0.41	0.39	0.39	0.37	0.39	0.37
	-0.46 -0.43 -0.35 -0.31 -0.31 -0.29 -0.29 -0.28	-0.46	-0.43	-0.35	-0.31	-0.31	-0.29	-0.29	-0.28	-0.29	-0.28
VSTRNA	0.37 0.37 0.37 0.36 0.36 0.36 0.35 0.35	0.37	0.37	0.37	0.36	0.36	0.36	0.35	0.35	0.35	0.35
	-0.28 -0.28 -0.28 -0.28 -0.27 -0.27 -0.26 -0.26	-0.28	-0.28	-0.28	-0.28	-0.27	-0.27	-0.26	-0.26	-0.26	-0.26
RANKED OUTPUT? 6 16											
VCBAC	0.52 0.46 0.46 0.42 0.42 0.40 0.40 0.39	0.52	0.46	0.46	0.42	0.42	0.40	0.40	0.39	0.40	0.39
	-0.38 -0.38 -0.37 -0.36 -0.35 -0.35 -0.33 -0.33	-0.38	-0.38	-0.37	-0.36	-0.35	-0.35	-0.33	-0.33	-0.33	-0.33
VCBAC	0.39 0.39 0.38 0.38 0.37 0.37 0.36 0.36	0.39	0.39	0.38	0.38	0.37	0.37	0.36	0.36	0.36	0.36
	-0.33 -0.32 -0.31 -0.31 -0.31 -0.31 -0.31 -0.30	-0.33	-0.32	-0.31	-0.31	-0.31	-0.31	-0.31	-0.30	-0.31	-0.30
RANKED OUTPUT? 7 16											
TRCGAC	0.16 0.13 0.13 0.12 0.12 0.12 0.11 0.11	0.16	0.13	0.13	0.12	0.12	0.12	0.11	0.11	0.11	0.11
	-0.19 -0.19 -0.19 -0.19 -0.18 -0.18 -0.18 -0.17	-0.19	-0.19	-0.19	-0.19	-0.18	-0.18	-0.18	-0.17	-0.18	-0.17
TRCGAC	0.11 0.11 0.10 0.10 0.09 0.08 0.08 0.08	0.11	0.11	0.10	0.10	0.09	0.08	0.08	0.08	0.08	0.08
	-0.17 -0.17 -0.17 -0.17 -0.17 -0.17 -0.17 -0.16	-0.17	-0.17	-0.17	-0.17	-0.17	-0.17	-0.16	-0.16	-0.16	-0.16

MEAN VALUE	NO. OF PEAKS	RMS
WAVEHT	0	0.00
PITCH	109	0.70
ROLL	135	1.57
VBOWAC	177	0.17
VSTRNA	46	0.10
VCBAC	61	0.11
TRCGAC	116	0.05
LRCGAC	0	0.00

SEAWORTHINESS TEST RESULTS IN LOW SEA STATE 4 (26 FEB 1980)

226501

RUN 1 FOLLOWING SEA, SES, APPROX. 10 KNOTS

CHRONOLOGICAL OUTPUT		AVERAGE		AVE 1/3		AVE 1/10		EXTREME	
	2 16	PK	TR	PK	TR	PK	TR	PK	TR
CHRONOLOGICAL OUTPUT 2 16									
PITCH	2.00	1.07	2.15	2.38	1.19	1.12	2.18	1.95	
	-1.22	-1.86	-1.46	-1.94	-1.45	-1.50	-2.18		
PITCH	0.80	0.88	1.77	1.95	1.07	0.81	1.50	0.50	
	-0.98	-1.87	-0.80	-1.97	-1.40	-0.60	-2.21	-0.91	
CHRONOLOGICAL OUTPUT 3 16									
ROLL	0.78	0.54	2.93	2.00	1.86	-0.05	2.20	2.00	
	-2.20	-0.93	-1.95	-2.69	-2.54	-1.03	-1.76	-2.54	
ROLL	2.25	3.03	2.15	2.15	1.17	2.69	1.07	1.76	
	-1.90	-1.95	-1.81	-0.44	-2.15	-1.17	-1.32	-1.76	
CHRONOLOGICAL OUTPUT 4 16									
VBOMAC	0.15	0.16	0.23	0.26	0.13	0.23	0.21	0.26	
	-0.08	-0.08	-0.08	0.02	-0.08	-0.08	-0.16	-0.16	
VBOMAC	0.20	0.11	0.21	0.13	0.28	0.11	0.16	0.11	
	-0.15	-0.08	-0.08	-0.13	-0.11	-0.11	-0.08	-0.08	
CHRONOLOGICAL OUTPUT 5 16									
VSTRNA	0.11	0.10	0.09	0.10	0.13	0.16	0.16	0.15	
	-0.02	-0.04	-0.02	-0.04	-0.03	0.01	-0.02	-0.05	
VSTRNA	0.11	0.11	0.11	0.13	0.10	0.11	0.12	0.20	
	-0.02	-0.05	-0.06	-0.05	0.00	-0.04	-0.08	-0.12	
CHRONOLOGICAL OUTPUT 6 16									
VCGAC	0.11	0.15	0.11	0.11	0.10	0.10	0.10	0.10	
	-0.03	0.00	-0.02	0.01	0.00	0.00	-0.02	0.00	
VCGAC	0.13	0.11	0.10	0.11	0.10	0.10	0.10	0.09	
	-0.02	-0.03	-0.02	0.00	-0.02	-0.02	0.00	-0.03	
CHRONOLOGICAL OUTPUT 7 16									
TRCGAC	0.06	0.06	0.06	0.09	0.04	0.05	0.01	0.04	
	-0.11	-0.10	-0.11	-0.08	-0.13	-0.09	-0.09	-0.09	
TRCGAC	0.05	0.04	0.04	0.03	0.03	0.08	0.02	0.04	
	-0.09	-0.09	-0.10	-0.08	-0.07	-0.10	-0.16	-0.09	
MEAN VALUE									
WAVEHT	-0.41								
PITCH	-0.04								
ROLL	-3.04								
VBOMAC	0.03								
VSTRNA	0.03								
VCGAC	0.04								
TRCGAC	-0.03								
LNCGAC	-0.04								
RHS									
	0.00								
	1.08								
	1.38								
	0.06								
	0.04								
	0.03								
	0.04								
	0.03								
	0.00								
NG. OF PEAKS									
	0								
	74								
	96								
	86								
	175								
	57								
	63								
	0								

SEAWORTHINESS TEST RESULTS IN LOW SEA STATE 4 (26 FEB 1980)

RUN 1 FOLLOWING SEA, WPB, APPROX. 10 KNOTS

226W01

CHRONOLOGICAL OUTPUT?		1 16		AVERAGE		AVE 1/3		AVE 1/10		EXTREME	
		PK	TR	PK	TR	PK	TR	PK	TR	PK	TR
PITCH	1.38 2.15 2.47 1.89 1.14 1.12 1.6F 2.05	1.35	-1.35	2.03	-2.19	2.47	-2.69	2.29	-2.34	2.18	-2.29
	-0.72 -0.44 -1.24 -2.10 0.11 -1.42 -0.24 -1.27	4.68	-4.71	8.03	-7.28	10.09	-9.12	12.35	-10.74	12.35	-10.74
PITCH	1.14 1.94 1.17 1.43 1.19 2.25 1.89 2.18	0.07	-0.06	0.08	-0.09	0.10	-0.11	0.11	-0.11	0.11	-0.13
	-2.05 -0.99 -1.06 -1.12 -1.17 -0.78 -1.25 -1.97	0.13	-0.12	0.19	-0.18	0.23	-0.22	0.27	-0.27	0.27	-0.27
		0.04	-0.11	0.05	-0.14	0.05	-0.14	0.05	-0.14	0.05	-0.14
RANKED OUTPUT? 1 16											
PITCH	2.99 2.69 3.47 2.43 2.29 2.25 2.18 2.15	-3.58	-2.77	-2.65	-2.64	-2.52	-2.34	-2.33	-2.29	-2.29	-2.29
PITCH	2.05 2.00 2.00 1.99 1.94 1.89 1.89 1.87	-2.26	-2.25	-2.23	-2.13	-2.13	-2.12	-2.10	-2.05	-2.05	-2.05
RANKED OUTPUT? 2 16											
ROLL	12.35 12.11 11.52 10.50 10.25 9.42 9.33 8.50	-10.74	-10.50	-10.16	-9.03	-8.94	-8.79	-8.50	-8.20	-8.20	-8.20
ROLL	8.45 8.45 8.40 8.40 8.35 8.25 8.25 8.25	-8.20	-8.11	-8.11	-8.06	-8.01	-7.81	-7.47	-7.47	-7.47	-7.47
RANKED OUTPUT? 3 16											
VCGAC	0.11 0.10 0.10 0.10 0.10 0.09 0.08 0.08	-0.13	-0.11	-0.10	-0.10	-0.09	-0.09	-0.09	-0.09	-0.09	-0.09
VCGAC	0.08 0.08 0.07 0.07 0.07 0.07 0.07 0.07	-0.08	-0.08	-0.07	-0.07	-0.07	-0.07	-0.07	-0.07	-0.07	-0.07
RANKED OUTPUT? 4 16											
TRCGAC	0.27 0.25 0.24 0.24 0.24 0.22 0.22 0.21	-0.27	-0.25	-0.23	-0.22	-0.22	-0.21	-0.21	-0.21	-0.21	-0.21
TRCGAC	0.21 0.20 0.20 0.20 0.19 0.19 0.19 0.18	-0.21	-0.19	-0.19	-0.18	-0.18	-0.18	-0.17	-0.17	-0.17	-0.17
RANKED OUTPUT? 5 2											
LNGGAC	0.05 0.04	0.05	0.04	0.05	0.04	0.05	0.04	0.05	0.04	0.05	0.04
	-0.14 -0.08	-0.14	-0.08	-0.14	-0.08	-0.14	-0.08	-0.14	-0.08	-0.14	-0.08

	MEAN VALUE	NO. OF PEAKS	RMS
PITCH	0.02	78	1.01
ROLL	-0.01	108	3.94
VCGAC	0.01	45	0.03
TRCGAC	0.00	103	0.09
LNGGAC	0.00	2	0.02

226S02

RUN 2 HEAD SEA, SES, APPROX. 10 KNOTS

CHRONOLOGICAL OUTPUT	2 16		3 16		4 16		5 16		6 16		7 16	
PITCH	1.81	0.72	0.67	0.52	0.59	1.03	1.12	0.94				
ROLL	-0.99	-1.63	-1.71	-0.80	-0.59	-0.86	-0.24	-0.05				
PITCH	1.45	1.04	1.40	0.65	1.35	1.86	2.13	1.76				
ROLL	-1.11	-0.24	-0.57	-0.76	-1.09	-1.16	-1.42	-0.49				
CHRONOLOGICAL OUTPUT	3 16		4 16		5 16		6 16		7 16		8 16	
PITCH	2.05	2.00	3.12	2.00	1.81	4.00	2.20	1.07				
ROLL	-1.22	-2.83	-2.83	-2.98	-1.61	-2.34	-2.98	-1.46				
PITCH	0.83	2.88	1.56	3.47	1.56	0.54	0.93	0.29				
ROLL	-0.39	-1.46	-2.25	-2.00	-2.59	-1.37	-0.49	-0.88				
CHRONOLOGICAL OUTPUT	4 16		5 16		6 16		7 16		8 16		9 16	
PITCH	0.35	0.15	0.28	0.24	0.46	0.44	0.24	0.28				
ROLL	-0.26	-0.08	-0.23	-0.18	-0.24	-0.42	-0.15	0.02				
PITCH	0.24	0.42	0.42	0.34	1.76	0.62	0.42	0.16				
ROLL	-0.24	-0.50	0.00	0.13	-0.60	-0.76	-0.13	-0.39				
CHRONOLOGICAL OUTPUT	5 16		6 16		7 16		8 16		9 16		10 16	
PITCH	0.14	0.20	0.20	0.28	0.51	0.26	0.12	0.48				
ROLL	-0.08	-0.08	-0.10	-0.04	-0.18	-0.11	-0.15	-0.15				
PITCH	0.60	0.18	0.02	0.37	0.64	0.33	0.38	0.20				
ROLL	-0.11	-0.46	-0.24	-0.20	0.08	-0.42	-0.15	-0.14				
CHRONOLOGICAL OUTPUT	6 16		7 16		8 16		9 16		10 16		11 16	
PITCH	0.16	0.20	0.18	0.67	0.28	0.17	0.28	0.13				
ROLL	-0.07	-0.04	-0.06	-0.20	-0.40	-0.16	-0.05	-0.11				
PITCH	0.23	0.20	0.20	0.12	0.16	0.13	0.13	0.15				
ROLL	-0.28	-0.07	-0.10	-0.15	-0.15	-0.09	-0.12	-0.12				
CHRONOLOGICAL OUTPUT	7 16		8 16		9 16		10 16		11 16		12 16	
PITCH	0.04	0.09	0.07	0.06	0.06	0.05	0.03	0.03				
ROLL	-0.08	-0.17	-0.08	-0.12	-0.12	-0.08	-0.08	-0.08				
PITCH	0.03	0.05	0.01	0.05	0.04	0.05	0.07	0.03				
ROLL	-0.08	-0.07	-0.10	-0.09	-0.08	-0.08	-0.09	-0.07				

MEAN VALUE	NO. OF PEAKS	RMS
-0.00	0	0.00
0.10	67	0.87
0.03	93	1.24
0.03	358	0.22
0.04	309	0.14
0.04	194	0.07
0.04	87	0.04
-0.03	0	0.00
-0.04	0	0.00

AVERAGE	AVE 1/3	AVE 1/10	EXTREME
PK	FK	FK	PK
TR	TR	TR	TR
1.29	2.02	2.57	3.27
-1.09	-1.83	-2.40	-3.01
1.61	2.62	3.24	4.00
-1.62	-2.53	-3.07	-3.47
0.37	0.66	1.06	2.23
-0.29	-0.56	-0.72	-1.14
0.32	0.55	0.77	1.03
-0.18	-0.32	-0.49	-0.84
0.21	0.31	0.45	0.80
-0.13	-0.22	-0.29	-0.46
0.04	0.07	0.09	0.18
-0.09	-0.12	-0.14	-0.17

SEAWORTHINESS TEST RESULTS IN LOW SEA STATE 4 (26 FEB 1980)

RUN 2 HEAD SEA, WPB, APPROX. 10 KNOTS

226W02

CHRONOLOGICAL OUTPUT	1 16				AVERAGE				AVE 1/3				AVE 1/10				EXTREME			
	PK	TR	PK	TR	PK	TR	PK	TR	PK	TR	PK	TR	PK	TR	PK	TR	PK	TR		
PITCH	4.02	1.69	1.30	2.78	0.75	2.70	4.82	3.22	2.24	-2.30	3.66	-3.54	4.46	-4.27	6.25	-6.36				
	-2.65	-2.02	-0.46	-1.42	-1.11	-0.65	-2.90													
PITCH	0.52	1.64	1.43	2.82	2.47	1.27	1.58	2.46	0.07	-0.06	0.08	-0.07	0.09	-0.09	0.12	-0.11				
	-1.33	-0.55	-0.15	-1.01	0.52	-2.08	-0.86													

CHRONOLOGICAL OUTPUT	2 16				RANKED OUTPUT				1 16									
	PK	TR	PK	TR	PK	TR	PK	TR	PK	TR	PK	TR						
ROLL	5.18	6.40	4.69	3.61	2.88	1.90	5.63	2.88	6.25	5.37	5.05	4.82	4.74	4.67	4.52	4.38		
	-4.15	-7.47	-6.59	-4.74	-2.64	-1.42	-5.13		-6.36	-4.59	-4.49	-4.43	-4.39	-4.35	-4.28	-4.26		
ROLL	8.11	5.57	6.69	3.52	1.22	2.34	3.08	6.10	4.23	4.22	4.17	4.12	4.02	3.99	3.96	3.94		
	-6.35	-10.99	-8.59	-6.93	-3.12	-1.07	-4.74		-4.22	-4.18	-3.97	-3.97	-3.96	-3.96	-3.92	-3.89		

CHRONOLOGICAL OUTPUT	3 16				RANKED OUTPUT				2 16									
	PK	TR	PK	TR	PK	TR	PK	TR	PK	TR	PK	TR						
VCGAC	0.06	0.07	0.07	0.07	0.05	0.07	0.10	0.05	9.57	8.11	7.91	7.23	6.88	6.84	6.69	6.69		
	-0.07	-0.07	-0.07	-0.05	-0.06	-0.11	-0.07		-10.99	-8.59	-7.86	-7.47	-6.93	-6.64	-6.59	-6.40		
VCGAC	0.05	0.07	0.07	0.08	0.07	0.06	0.07	0.07	6.40	6.25	6.10	5.96	5.91	5.76	5.71	5.71		
	-0.05	-0.05	-0.04	-0.05	-0.07	-0.04	-0.04		-6.35	-6.20	-6.01	-6.01	-5.96	-5.91	-5.86	-5.66		

CHRONOLOGICAL OUTPUT	4 16				RANKED OUTPUT				3 16									
	PK	TR	PK	TR	PK	TR	PK	TR	PK	TR	PK	TR						
TRCGAC	0.15	0.18	0.17	0.13	0.13	0.12	0.07	0.13	0.12	0.10	0.09	0.08	0.08	0.08	0.08	0.08		
	-0.11	-0.14	-0.11	-0.08	-0.12	-0.06	-0.07		-0.11	-0.09	-0.09	-0.08	-0.08	-0.08	-0.07	-0.07		
TRCGAC	0.09	0.16	0.30	0.08	0.22	0.15	0.08	0.07	0.07	0.07	0.07	0.07	0.07	0.07	0.07	0.07		
	-0.07	-0.07	-0.30	-0.09	-0.11	-0.17	-0.05		-0.07	-0.07	-0.07	-0.07	-0.07	-0.07	-0.07	-0.07		

CHRONOLOGICAL OUTPUT	5 16				RANKED OUTPUT				4 16									
	PK	TR	PK	TR	PK	TR	PK	TR	PK	TR	PK	TR						
LMCGAC	0.05	0.07	0.04	0.07	0.09	0.07	0.07	0.04	0.30	0.26	0.24	0.23	0.22	0.19	0.19	0.18		
	-0.08	-0.10	-0.06	-0.10	-0.14	-0.08	-0.07		-0.30	-0.23	-0.23	-0.22	-0.20	-0.20	-0.18	-0.18		
LMCGAC	0.05	0.07	0.04	0.08	0.09	0.09	0.07	0.06	0.17	0.17	0.17	0.17	0.17	0.17	0.17	0.16		
	-0.05	-0.09	-0.16	-0.13	-0.11	-0.12	-0.09		-0.18	-0.18	-0.17	-0.17	-0.17	-0.16	-0.16	-0.16		

MEAN VALUE	NO. OF PEAKS	RMS	RANKED OUTPUT			
			5 16	4 16	3 16	2 16
PITCH	180	1.80	0.15	0.12	0.11	0.11
ROLL	103	2.93	-0.36	-0.32	-0.31	-0.30
VCGAC	63	0.03	0.11	0.10	0.10	0.10
TRCGAC	115	0.08	0.10	0.10	0.10	0.10
LMCGAC	151	0.06	-0.20	-0.20	-0.19	-0.19

226S03

## RUN 3 S. BOW SEA, SES, APPROX. 10 KNOTS

CHRONOLOGICAL OUTPUT?		2 16		AVERAGE		AVE 1/3		AVE 1/10		EXTREME	
		PK	TR	PK	TR	PK	TR	PK	TR	PK	TR
PITCH	1.63	1.69	-0.07	1.74	1.46	1.82	1.64	1.81	-2.34	1.86	-2.67
	-1.89	-1.63	-1.29	-1.89	-1.69	-1.90	-0.52	4.50	-3.67	5.37	-4.25
ROLL	2.25	-1.64	3.48	0.27	-0.27	0.34	-0.40	0.34	-0.40	0.54	-0.55
VRWAC	0.19	-0.16	0.27	-0.11	0.27	-0.17	0.36	0.36	-0.24	0.55	-0.51
VSTRNA	0.19	-0.11	0.27	-0.11	0.27	-0.17	0.36	0.36	-0.24	0.55	-0.51
VCGAC	0.16	-0.09	0.18	-0.12	0.18	-0.12	0.21	0.21	-0.16	0.26	-0.22
TRCGAC	0.06	-0.12	0.09	-0.15	0.09	-0.15	0.13	0.13	-0.19	0.18	-0.28

CHRONOLOGICAL OUTPUT?		3 16		RANKED OUTPUT?		2 16	
ROLL	1.95	1.32	0.83	2.98	0.78	2.00	3.27
	-3.37	-0.49	-0.54	-1.66	-0.39	-1.42	-0.88
ROLL	1.51	1.81	1.46	1.46	1.81	0.98	2.83
	-0.44	-0.54	-0.59	-0.98	-0.63	-0.98	-1.03

CHRONOLOGICAL OUTPUT?		4 16		RANKED OUTPUT?		3 16	
VRWAC	0.23	0.16	0.31	0.16	0.13	0.20	0.13
	-0.29	-0.08	-0.23	-0.20	-0.10	-0.13	-0.11
VRWAC	0.20	0.16	0.15	0.24	0.10	0.08	0.20
	-0.33	-0.10	-0.13	-0.08	-0.10	-0.26	-0.16

CHRONOLOGICAL OUTPUT?		5 16		RANKED OUTPUT?		4 16	
VSTRNA	0.15	0.17	0.18	0.17	0.23	0.15	0.12
	-0.06	-0.15	-0.10	-0.09	-0.13	-0.04	-0.09
VSTRNA	0.28	0.31	0.16	0.20	0.15	0.14	0.17
	-0.23	-0.22	-0.19	-0.07	-0.10	-0.06	-0.07

CHRONOLOGICAL OUTPUT?		6 16		RANKED OUTPUT?		5 16	
VCGAC	0.16	0.13	0.16	0.15	0.15	0.18	0.15
	-0.07	-0.07	-0.07	-0.11	-0.07	-0.05	-0.07
VCGAC	0.14	0.14	0.18	0.16	0.12	0.19	0.15
	-0.06	-0.14	-0.10	-0.07	-0.11	-0.05	-0.08

CHRONOLOGICAL OUTPUT?		7 16		RANKED OUTPUT?		6 16	
TRCGAC	0.03	0.03	0.08	0.07	0.04	0.03	0.06
	-0.08	-0.10	-0.13	-0.11	-0.13	-0.07	-0.14
TRCGAC	0.07	0.06	0.07	0.05	0.12	0.03	0.08
	-0.13	-0.14	-0.11	-0.09	-0.13	-0.14	-0.16

	MEAN VALUE	NO. OF PEAKS	RMS
WAVEHT	-0.01	0	0.00
PITCH	0.04	39	0.82
ROLL	0.32	108	1.52
VRWAC	0.02	206	0.09
VSTRNA	0.03	133	0.06
VCGAC	0.04	53	0.04
TRCGAC	-0.02	116	0.06
LNCGAC	-0.05	0	0.00

SEAWORTHINESS TEST RESULTS IN LOW SEA STATE 4 (26 FEB 1980)

226W03

RUN 3 S. BOW SEA, WPB, APPROX. 10 KNOTS

	AVERAGE		AVE 1/3		AVE 1/10		EXTREME	
	PK	TR	PK	TR	PK	TR	PK	TR
PITCH	1.19	-1.20	1.96	-1.98	2.52	-2.60	3.40	-3.55
ROLL	3.89	-3.99	6.12	-6.92	8.06	-8.85	10.25	-10.79
VEGAC	0.07	-0.05	0.08	-0.07	0.10	-0.11	0.10	-0.11
TRCGAC	0.12	-0.12	0.19	-0.17	0.24	-0.20	0.29	-0.32
LNCGAC	0.06	-0.07	0.07	-0.10	0.08	-0.12	0.10	-0.18

RANKED OUTPUT? 1 16

PITCH	3.60	3.12	2.75	2.67	2.62	2.56	2.49	2.46
	-3.55	-3.04	-2.93	-2.72	-2.62	-2.60	-2.56	-2.54
PITCH	2.34	2.33	2.31	2.26	2.23	2.21	2.21	2.12
	-2.49	-2.49	-2.39	-2.38	-2.36	-2.33	-2.33	-2.23

RANKED OUTPUT? 2 16

ROLL	10.25	8.94	8.64	8.11	7.91	7.76	7.57	7.47
	-10.79	-10.01	-8.89	-8.79	-8.74	-8.64	-8.25	-8.15
ROLL	7.08	6.88	6.88	6.49	6.40	6.30	6.15	5.62
	-8.11	-8.11	-8.06	-7.71	-7.62	-7.52	-6.88	-6.84

RANKED OUTPUT? 3 16

VEGAC	0.10	0.09	0.08	0.08	0.07	0.07	0.07	0.07
	-0.11	-0.08	-0.07	-0.06	-0.06	-0.06	-0.05	-0.05
VEGAC	0.07	0.07	0.07	0.07	0.07	0.07	0.06	0.06
	-0.05	-0.04	-0.04	-0.04	-0.04	-0.04	-0.03	-0.03

RANKED OUTPUT? 4 16

TRCGAC	0.29	0.26	0.25	0.25	0.25	0.25	0.24	0.24
	-0.32	-0.21	-0.21	-0.21	-0.20	-0.20	-0.18	-0.18
TRCGAC	0.23	0.22	0.21	0.21	0.21	0.20	0.19	0.19
	-0.18	-0.18	-0.18	-0.18	-0.17	-0.17	-0.16	-0.16

RANKED OUTPUT? 5 16

LNCGAC	0.10	0.08	0.08	0.08	0.08	0.08	0.08	0.08
	-0.18	-0.12	-0.12	-0.11	-0.11	-0.10	-0.10	-0.10
LNCGAC	0.08	0.08	0.08	0.08	0.08	0.08	0.07	0.07
	-0.10	-0.10	-0.10	-0.09	-0.09	-0.09	-0.09	-0.09

CHRONOLOGICAL OUTPUT? 1 16

PITCH	1.43	1.48	2.21	2.31	1.25	1.69	2.08	1.86
	0.08	-1.32	-1.64	-0.23	-0.13	-1.79	-2.62	-0.41
PITCH	2.12	1.19	1.30	2.26	0.94	0.91	2.56	3.60
	-0.49	-2.33	-0.96	-1.68	-0.80	-1.20	-1.66	-2.39

CHRONOLOGICAL OUTPUT? 2 16

ROLL	3.17	2.29	5.42	-0.93	6.30	2.73	4.05	5.37
	-2.00	-1.66	-4.74	-3.03	-7.62	-3.56	-1.42	-1.86
ROLL	3.96	8.11	4.05	7.91	5.32	6.40	6.49	4.98
	-4.44	-3.37	-7.71	-8.64	-5.91	-6.35	-8.79	-8.11

CHRONOLOGICAL OUTPUT? 3 16

VEGAC	0.07	0.07	0.06	0.07	0.07	0.07	0.07	0.07
	-0.06	-0.03	-0.08	-0.04	-0.06	-0.03	-0.06	-0.03
VEGAC	0.06	0.06	0.08	0.05	0.07	0.07	0.09	0.08
	-0.04	-0.04	-0.07	-0.11	-0.05	-0.04	-0.05	-0.05

CHRONOLOGICAL OUTPUT? 4 16

TRCGAC	0.21	0.12	0.09	0.24	0.05	0.09	0.13	0.10
	-0.06	-0.09	-0.15	-0.11	-0.13	-0.06	-0.11	-0.15
TRCGAC	0.17	0.20	0.15	0.26	0.13	0.19	0.22	0.25
	-0.09	-0.10	-0.21	-0.13	-0.21	-0.14	-0.18	-0.14

CHRONOLOGICAL OUTPUT? 5 16

LNCGAC	0.05	0.06	0.08	0.07	0.05	0.08	0.05	0.06
	-0.06	-0.06	-0.09	-0.11	-0.06	-0.09	-0.10	-0.08
LNCGAC	0.05	0.08	0.06	0.06	0.06	0.07	0.10	0.08
	-0.06	-0.18	-0.10	-0.05	-0.05	-0.05	-0.12	-0.12

	MEAN VALUE	NO. OF PEAKS	RMS
PITCH	-0.00	169	0.96
ROLL	-0.00	106	3.27
VEGAC	0.01	18	0.02
TRCGAC	0.00	112	0.08
LNCGAC	0.00	74	0.03

SEAWORTHINESS TEST RESULTS IN LOW SEA STATE 4 (26 FEB 1980)

RUN 4 P. QUARTERING SEA, SES, APPROX. 10 KNOTS

226S04

CHRONOLOGICAL OUTPUT? 2 16

PITCH 1.16 0.80 1.95 1.06 2.34 1.50 1.12 0.07  
 -2.44 -0.46 -1.68 -1.71 -2.38 -2.64 -1.58 -1.46  
 FITCH 0.68 0.65 0.86 1.71 1.20 1.37 1.69 1.17  
 -1.04 -0.90 -1.03 -2.73 -1.89 -1.11 -2.18 -1.73

CHRONOLOGICAL OUTPUT? 3 16

ROLL 0.68 2.15 0.34 2.05 1.17 1.61 2.78 0.54  
 -0.98 -1.12 -1.71 -0.68 -1.90 1.03 -2.39 -1.81  
 ROLL 1.22 1.81 0.54 1.76 1.86 1.17 1.03 1.86  
 -0.93 -1.32 -0.78 -0.93 -2.44 -1.51 -0.20 -2.00

CHRONOLOGICAL OUTPUT? 4 16

VBOWAC 0.24 0.15 0.18 0.20 0.24 0.26 0.28 0.21  
 -0.23 -0.18 -0.31 -0.33 -0.18 -0.20 -0.28 -0.26  
 VBOWAC 0.20 0.20 0.11 0.15 0.13 0.16 0.23 0.36  
 -0.11 -0.20 -0.03 -0.08 -0.11 -0.07 -0.08 -0.33

CHRONOLOGICAL OUTPUT? 5 16

USTRNA 0.29 0.25 0.35 0.28 0.19 0.26 0.24 0.16  
 -0.07 -0.05 -0.03 -0.03 -0.02 -0.15 -0.11 -0.07  
 USTRNA 0.20 0.25 0.28 0.13 0.10 0.15 0.19 0.25  
 -0.07 -0.06 -0.15 -0.08 -0.12 -0.13 -0.07 -0.10

CHRONOLOGICAL OUTPUT? 6 16

VCGAC 0.23 0.27 0.15 0.16 0.14 0.14 0.18 0.20  
 -0.09 -0.07 -0.07 -0.07 -0.08 -0.06 -0.07 -0.09  
 VCGAC 0.24 0.15 0.15 0.15 0.18 0.18 0.20 0.13  
 -0.11 -0.14 -0.11 -0.07 -0.05 -0.02 -0.07 -0.07

CHRONOLOGICAL OUTPUT? 7 16

TRCGAC 0.04 0.03 0.03 0.02 0.07 0.01 0.02 0.04  
 -0.07 -0.11 -0.08 -0.09 -0.09 -0.10 -0.09 -0.12  
 TRCGAC 0.04 0.10 0.08 0.08 0.07 0.05 0.05 0.03  
 -0.07 -0.08 -0.19 -0.09 -0.14 -0.10 -0.06 -0.12

MEAN VALUE	NO. OF PEAKS	RMS
WAVEHT	-2	0.00
PITCH	112	1.24
ROLL	117	1.60
VBOWAC	164	0.11
USTRNA	133	0.07
VCGAC	20	0.04
TRCGAC	105	0.05
LWCGAC	-2	0.00

AVERAGE AVE 1/3 AVE 1/10 EX EME  
 PK TR PK TR PK TR PK TR  
 PITCH 1.55 -1.79 2.35 -2.61 3.11 3.45  
 ROLL 2.06 -2.04 3.28 -3.30 4.18 5.32  
 VBOWAC 0.22 -0.15 0.31 -0.26 0.37 0.49  
 USTRNA 0.20 -0.11 0.29 -0.19 0.39 0.53  
 VCGAC 0.17 -0.08 0.22 -0.10 0.26 0.37  
 TRCGAC 0.06 -0.11 0.09 -0.14 0.12 0.14

RANKED OUTPUT? 2 16

PITCH 3.45 3.42 3.27 3.14 2.99 2.85 2.80  
 -3.69 -3.42 -3.21 -3.14 -3.12 -3.11 -2.96 -2.93  
 PITCH 2.65 2.60 2.57 2.51 2.46 2.43 2.39 2.34  
 -2.93 -2.86 -2.83 -2.75 -2.73 -2.64 -2.64

RANKED OUTPUT? 3 16

ROLL 5.32 4.93 4.54 4.49 4.00 3.86 3.81  
 -5.66 -5.57 -4.64 -4.44 -4.20 -4.10 -4.00 -3.96  
 ROLL 3.81 3.66 3.66 3.56 3.56 3.42 3.27 3.22  
 -3.56 -3.56 -3.47 -3.42 -3.42 -3.37 -3.37

RANKED OUTPUT? 4 16

VBOWAC 0.49 0.42 0.41 0.39 0.39 0.37 0.37 0.37  
 -0.44 -0.42 -0.41 -0.36 -0.33 -0.33 -0.33 -0.33  
 VBOWAC 0.36 0.36 0.36 0.34 0.34 0.34 0.33 0.33  
 -0.31 -0.29 -0.29 -0.28 -0.28 -0.28 -0.28 -0.26

RANKED OUTPUT? 5 16

USTRNA 0.53 0.48 0.46 0.46 0.42 0.41 0.40 0.35  
 -0.37 -0.35 -0.27 -0.25 -0.24 -0.24 -0.24 -0.23  
 USTRNA 0.34 0.33 0.32 0.29 0.29 0.29 0.29 0.28  
 -0.22 -0.21 -0.21 -0.21 -0.21 -0.21 -0.20 -0.20

RANKED OUTPUT? 6 16

VCGAC 0.27 0.24 0.23 0.20 0.20 0.18 0.18 0.18  
 -0.14 -0.11 -0.11 -0.09 -0.09 -0.08 -0.08 -0.07  
 VCGAC 0.17 0.16 0.15 0.15 0.15 0.15 0.15 0.15  
 -0.07 -0.07 -0.07 -0.07 -0.07 -0.07 -0.07 -0.07

RANKED OUTPUT? 7 16

TRCGAC 0.14 0.14 0.12 0.12 0.11 0.11 0.11 0.11  
 -0.19 -0.18 -0.17 -0.17 -0.16 -0.16 -0.16 -0.15  
 TRCGAC 0.10 0.10 0.09 0.09 0.09 0.09 0.09 0.09  
 -0.15 -0.14 -0.14 -0.14 -0.14 -0.14 -0.14 -0.14

SEAWORTHINESS TEST RESULTS IN LOW SEA STATE 4 (26 FEB 1980)

226W04

RUN 4 P. QUARTERING SEA, WPB, APPROX. 10 KNOTS

CHRONOLOGICAL OUTPUT		AVERAGE		AVE 1/3		AVE 1/10		EXTREME	
PK	TR	PK	TR	PK	TR	PK	TR	PK	TR
PITCH	1.04	3.24	2.13	1.53	1.97	2.28	3.24	1.24	1.24
	-0.59	-1.53	-1.90	-0.42	-1.66	-0.72	-2.75	-1.53	
PITCH	1.06	2.10	1.63	1.63	1.63	0.05	1.89	0.66	0.66
	-0.21	-1.29	-2.52	-0.94	0.20	-1.03	-1.09	-2.20	
CHRONOLOGICAL OUTPUT		2 16							
ROLL	7.03	2.05	4.98	10.06	4.98	6.25	11.13	5.03	5.03
	-8.45	-1.66	-0.44	-8.25	-7.81	-3.52	-6.25	-9.03	
ROLL	4.54	6.74	2.00	2.88	9.96	7.08	4.44	2.64	2.64
	-6.05	-1.37	-2.93	-1.71	-5.71	-4.79	-7.32	-0.93	
CHRONOLOGICAL OUTPUT		3 16							
VCGAC	0.08	0.10	0.06	0.07	0.06	0.06	0.06	0.08	0.06
	-0.05	-0.09	-0.09	-0.07	-0.07	-0.06	-0.06	-0.07	
VCGAC	0.07	0.06	0.07	0.05	0.06	0.06	0.08	0.08	0.09
	-0.06	-0.11	-0.08	-0.06	-0.06	-0.05	-0.07	-0.09	
CHRONOLOGICAL OUTPUT		4 16							
TRCGAC	0.01	0.03	0.17	0.18	0.17	0.25	0.22	0.13	0.13
	-0.14	-0.09	-0.14	-0.21	-0.17	-0.27	-0.30	-0.13	
TRCGAC	0.02	0.03	0.13	0.18	0.16	0.11	0.17	0.23	0.23
	-0.09	-0.16	-0.18	-0.07	-0.10	-0.12	-0.18	-0.20	
CHRONOLOGICAL OUTPUT		5 16							
LNGCAG	0.07	0.05	0.05	0.05	0.04	0.05	0.05	0.04	0.04
	-0.12	-0.07	-0.08	-0.06	-0.07	-0.06	-0.05	-0.06	
LNGCAG	0.05	0.04	0.04	0.05	0.04	0.05	0.04	0.04	0.06
	-0.07	-0.07	-0.06	-0.09	-0.08	-0.08	-0.07	-0.07	
MEAN VALUE		NO. OF PEAKS		RMS					
PITCH	0.01	129	1.13						
ROLL	-0.02	107	4.99						
VCGAC	0.00	88	0.04						
TRCGAC	0.00	109	0.11						
LNGCAG	-0.01	32	0.03						
RANKED OUTPUT									
RANKED OUTPUT 1 16									
PITCH	3.99	3.24	3.22	2.82	2.75	2.73	2.69	2.52	2.52
	-3.53	-3.06	-2.83	-2.75	-2.65	-2.65	-2.64	-2.59	
PITCH	2.49	2.41	2.36	2.33	2.31	2.28	2.26	2.25	2.25
	-2.57	-2.56	-2.54	-2.54	-2.52	-2.43	-2.33	-2.29	
RANKED OUTPUT 2 16									
ROLL	17.68	15.72	14.94	13.72	12.84	12.35	12.01	11.67	11.67
	-14.99	-14.31	-12.94	-12.70	-11.91	-11.62	-10.99	-10.40	
ROLL	11.62	11.82	11.67	11.67	11.13	10.74	10.50	10.25	10.25
	-9.96	-9.96	-9.77	-9.37	-9.33	-9.13	-9.13	-9.13	
RANKED OUTPUT 3 16									
VCGAC	0.13	0.11	0.10	0.10	0.10	0.10	0.09	0.09	0.09
	-0.12	-0.12	-0.11	-0.11	-0.11	-0.11	-0.11	-0.11	
VCGAC	0.09	0.09	0.09	0.09	0.09	0.09	0.09	0.09	0.08
	-0.10	-0.10	-0.10	-0.10	-0.09	-0.09	-0.09	-0.09	
RANKED OUTPUT 4 16									
TRCGAC	0.36	0.34	0.31	0.31	0.29	0.28	0.27	0.27	0.27
	-0.36	-0.35	-0.32	-0.30	-0.29	-0.28	-0.28	-0.27	
TRCGAC	0.27	0.27	0.26	0.26	0.26	0.25	0.25	0.25	0.25
	-0.27	-0.27	-0.27	-0.27	-0.26	-0.25	-0.25	-0.24	
RANKED OUTPUT 5 16									
LNGCAG	0.07	0.06	0.06	0.06	0.06	0.06	0.06	0.06	0.06
	-0.12	-0.12	-0.10	-0.10	-0.09	-0.09	-0.08	-0.08	
LNGCAG	0.05	0.05	0.05	0.05	0.05	0.05	0.05	0.05	0.05
	-0.08	-0.08	-0.08	-0.08	-0.07	-0.07	-0.07	-0.07	

SEAWORTHINESS TEST RESULTS IN LOW SEA STATE 4 (26 FEB 1980)

RUN 5 P. BEAM SEA, SES, APPROX. 10 KNOTS

226S05

	CHRONOLOGICAL OUTPUT? 2 16				AVERAGE				AVE 1/3				EXTREME			
	PK	TR	PK	TR	PK	TR	PK	TR	PK	TR	PK	TR	PK	TR	PK	TR
PITCH	1.30	0.13	1.64	0.60	0.62	0.96	0.98	0.73	1.74	-2.15	2.40	-2.62	2.91	-2.80	2.91	-2.80
ROLL	-1.89	-0.98	-1.04	-1.24	-0.46	-1.38	-0.16	-1.77	4.18	-4.82	5.48	-6.18	7.18	-7.28	7.18	-7.28
VBOWAC	0.21	0.21	0.21	0.21	0.21	0.21	0.21	0.21	0.29	-0.34	0.35	-0.45	0.68	-0.55	0.68	-0.55
VSTRNA	0.24	0.50	0.99	0.52	0.42	1.33	0.68	0.73	0.19	-0.19	0.44	-0.26	0.58	-0.36	0.58	-0.36
VCGAC	-1.17	-1.63	-0.98	-1.42	-1.24	-1.74	-0.31	-0.85	0.17	-0.13	0.18	-0.16	0.19	-0.20	0.19	-0.20
TRCGAC	0.07	-0.13	0.12	-0.17	-0.17	-0.17	-0.17	-0.22	0.12	-0.17	0.16	-0.19	0.22	-0.22	0.19	-0.22

	RANKED OUTPUT? 2 16							
PITCH	2.91	2.77	2.56	2.54	2.41	2.36	2.12	2.08
ROLL	-2.80	-2.75	-2.70	-2.67	-2.65	-2.64	-2.52	-2.43
FITCH	1.89	1.73	1.64	1.61	1.60	1.60	1.60	1.58
TRCGAC	-2.41	-2.34	-2.23	-2.21	-2.18	-2.13	-2.10	-2.03

	RANKED OUTPUT? 3 16							
PITCH	7.18	6.05	5.86	5.62	5.27	5.22	5.18	4.88
ROLL	-7.26	-7.13	-6.45	-6.45	-6.25	-6.20	-5.81	-5.66
FITCH	4.79	4.74	4.64	4.64	4.39	4.30	4.15	4.15
TRCGAC	-5.62	-4.93	-4.93	-4.88	-4.88	-4.83	-4.79	-4.79

	RANKED OUTPUT? 4 16							
PITCH	0.68	0.44	0.37	0.36	0.36	0.36	0.36	0.34
ROLL	-0.55	-0.52	-0.50	-0.49	-0.49	-0.49	-0.47	-0.46
FITCH	0.33	0.31	0.31	0.31	0.31	0.29	0.29	0.29
TRCGAC	-0.46	-0.46	-0.44	-0.42	-0.42	-0.41	-0.39	-0.39

	RANKED OUTPUT? 5 16							
PITCH	0.58	0.50	0.49	0.46	0.45	0.43	0.42	0.42
ROLL	-0.36	-0.34	-0.33	-0.28	-0.28	-0.26	-0.26	-0.24
FITCH	0.41	0.41	0.40	0.39	0.39	0.38	0.38	0.37
TRCGAC	-0.24	-0.24	-0.22	-0.21	-0.20	-0.20	-0.20	-0.20

	RANKED OUTPUT? 6 16							
PITCH	0.19	0.19	0.18	0.18	0.18	0.18	0.17	0.17
ROLL	-0.20	-0.16	-0.16	-0.13	-0.13	-0.13	-0.12	-0.12
FITCH	0.16	0.16	0.16	0.16	0.16	0.16	0.16	0.15
TRCGAC	-0.12	-0.11	-0.11	-0.11	-0.11	-0.11	-0.10	-0.10

	RANKED OUTPUT? 7 16							
PITCH	0.22	0.20	0.20	0.17	0.16	0.14	0.14	0.14
ROLL	-0.22	-0.22	-0.20	-0.20	-0.20	-0.19	-0.19	-0.16
FITCH	0.14	0.14	0.13	0.13	0.13	0.13	0.12	0.12
TRCGAC	-0.18	-0.18	-0.17	-0.17	-0.17	-0.17	-0.17	-0.16

	MEAN VALUE	NO. OF PEAKS	RMS
WAVEHT	0.01	0	0.00
PITCH	-0.16	90	0.93
ROLL	-0.30	107	2.24
VBOWAC	0.03	180	0.12
VSTRNA	0.03	141	0.08
VCGAC	0.04	47	0.05
TRCGAC	-0.03	112	0.06
LNCGAC	-0.05	0	0.00

SEAWORTHINESS TEST RESULTS IN LOW SEA STATE 4 (26 FEB 1980)

RUN 5 P. BEAM SEA, WPB, APPROX. 10 KNOTS

226W05

CHRONOLOGICAL OUTPUT?	AVERAGE				AVE 1/3				AVE 1/10				EXTREME			
	PK	TR	PK	TR	PK	TR	PK	TR	PK	TR	PK	TR	PK	TR		
CHRONOLOGICAL OUTPUT? 1 16																
PITCH	1.51	1.97	1.58	3.06	1.90	0.90	0.81	1.01	1.81	-1.76	2.88	-2.94	3.62	-3.70	4.82	-5.47
ROLL	-1.97	-0.39	-1.58	-1.60	-1.92	-0.57	-1.01	-0.83	6.56	-6.61	11.41	-10.57	15.10	-13.60	22.22	-17.07
FITCH	1.03	1.07	1.61	1.33	1.43	0.57	2.86	2.54	0.07	-0.10	0.10	-0.14	0.12	-0.18	0.15	-0.21
	-1.29	-0.10	-1.19	-2.47	-0.62	-0.60	-0.54	-3.16	TRCGAC	0.15	-0.19	0.24	-0.28	0.32	-0.34	0.46
									LMCGAC	0.07	-0.09	0.09	-0.12	0.15	-0.14	0.61
CHRONOLOGICAL OUTPUT? 2 16																
ROLL	15.58	13.13	5.08	7.96	10.99	10.74	2.54	12.11	PITCH	4.82	4.36	4.26	4.04	3.84	3.75	3.60
	-16.75	-17.09	-9.18	-5.76	-11.91	-11.08	-6.15	-7.13	ROLL	-5.47	-4.75	-4.54	-3.73	-3.71	-3.60	-3.60
ROLL	4.64	0.93	3.22	9.28	1.51	6.98	1.86	9.47	PITCH	3.47	3.39	3.29	3.26	3.24	3.14	3.11
	-10.94	-2.69	-2.29	-4.79	-6.45	-2.15	-5.91	-5.52	ROLL	-3.58	-3.43	-3.34	-3.32	-3.29	-3.21	-3.19
CHRONOLOGICAL OUTPUT? 3 16																
VCGAC	0.06	0.05	0.02	0.10	0.02	0.04	0.10	0.04	ROLL	22.22	16.60	15.58	15.19	14.60	14.50	14.36
	-0.11	-0.10	-0.08	-0.13	-0.08	-0.10	-0.09	-0.07	ROLL	-17.09	-16.75	-15.58	-15.04	-14.99	-13.62	-11.91
VCGAC	0.06	0.05	0.05	0.06	0.06	0.15	0.08	0.07	ROLL	13.18	13.13	12.30	12.21	12.16	12.11	11.87
	-0.07	-0.08	-0.06	-0.06	-0.07	-0.11	-0.17	-0.08	ROLL	-11.28	-11.08	-10.99	-10.94	-10.79	-10.74	-10.50
CHRONOLOGICAL OUTPUT? 4 16																
TRCGAC	0.36	0.19	0.11	0.18	0.18	0.23	0.26	0.17	VCGAC	0.15	0.13	0.13	0.12	0.12	0.12	0.11
	-0.22	-0.24	-0.12	-0.17	-0.18	-0.24	-0.23	-0.30	ROLL	-0.21	-0.20	-0.19	-0.18	-0.17	-0.16	-0.16
TRCGAC	0.06	0.06	0.10	0.13	0.08	0.06	0.08	0.18	VCGAC	0.11	0.11	0.11	0.10	0.10	0.10	0.10
	-0.09	-0.11	-0.17	-0.18	-0.14	-0.18	-0.10	-0.22	ROLL	-0.15	-0.15	-0.14	-0.14	-0.14	-0.14	-0.13
CHRONOLOGICAL OUTPUT? 5 16																
LMCGAC	0.07	0.06	0.06	0.06	0.07	0.06	0.05	0.06	TRCGAC	0.46	0.45	0.36	0.31	0.31	0.30	0.29
	-0.10	-0.09	-0.12	-0.06	-0.06	-0.12	-0.06	-0.06	ROLL	-0.47	-0.40	-0.36	-0.35	-0.34	-0.33	-0.31
LMCGAC	0.05	0.06	0.05	0.08	0.06	0.06	0.07	0.06	TRCGAC	0.26	0.26	0.25	0.24	0.24	0.24	0.23
	-0.06	-0.09	-0.06	-0.07	-0.10	-0.11	-0.10	-0.15	ROLL	-0.31	-0.30	-0.30	-0.30	-0.30	-0.28	-0.28
MEAN VALUE NO. OF PEAKS RMS																
PITCH	0.01	170	1.45													
ROLL	0.06	111	5.64													
VCGAC	-0.02	96	0.05													
TRCGAC	-0.03	118	0.13													
LMCGAC	-0.00	108	0.04													

SEAWORTHINESS TEST RESULTS IN LOW SEA STATE 4 (26 FEB 1980)

RUN 6 S. BEAM SEA, SES, APPROX. 15 KNOTS

226S06

CHRONOLOGICAL OUTPUT?	2 16		AVERAGE		AVE 1/3		AVE 1/10		EXTREME							
	PK	TR	PK	TR	PK	TR	PK	TR	PK	TR						
PITCH	1.66	0.37	2.08	2.16	1.33	1.25	3.66	1.97	1.67	-1.39	2.78	-2.65	3.38	-3.37	3.66	-4.00
FITCH	-0.24	-1.77	-0.72	0.65	-2.43	0.21	-0.70	-2.72	3.41	-2.50	5.35	-4.58	6.44	-6.16	6.98	-8.64
PITCH	1.69	-0.44	2.21	3.12	3.04	0.24	1.06	1.37	0.19	-0.19	0.26	-0.29	0.31	-0.40	0.37	-0.60
FITCH	0.70	-2.21	-2.69	0.26	0.72	-1.92	-2.98	0.00	0.21	-0.09	0.29	-0.13	0.36	-0.17	0.48	-0.30
VEGAC	0.16	-0.09	0.19	-0.12	0.22	-0.14	0.27	-0.16	0.16	-0.09	0.19	-0.12	0.22	-0.14	0.27	-0.16
TRCGAC	0.08	-0.14	0.12	-0.20	0.15	-0.25	0.18	-0.28	0.08	-0.14	0.12	-0.20	0.15	-0.25	0.18	-0.28

RANKED OUTPUT?		2 16	
FITCH	3.66	3.65	3.12
FITCH	-4.00	-3.35	-3.16
PITCH	2.49	2.47	2.46
PITCH	-2.31	-2.29	-2.25

RANKED OUTPUT?		3 16	
ROLL	6.98	6.93	6.79
ROLL	-8.64	-7.13	-6.98
ROLL	6.05	6.01	6.01
ROLL	-5.27	-5.18	-5.08

RANKED OUTPUT?		4 16	
UROWAC	0.37	0.36	0.36
UROWAC	-0.60	-0.57	-0.54
UROWAC	0.31	0.29	0.29
UROWAC	-0.37	-0.37	-0.36

RANKED OUTPUT?		5 16	
USTRNA	0.48	0.43	0.41
USTRNA	-0.30	-0.26	-0.22
USTRNA	0.33	0.33	0.33
USTRNA	-0.13	-0.13	-0.13

RANKED OUTPUT?		6 16	
VEGAC	0.27	0.22	0.21
VEGAC	-0.16	-0.15	-0.15
VEGAC	0.18	0.18	0.18
VEGAC	-0.12	-0.11	-0.11

RANKED OUTPUT?		7 16	
TRCGAC	0.18	0.17	0.16
TRCGAC	-0.28	-0.28	-0.28
TRCGAC	0.15	0.15	0.13
TRCGAC	-0.24	-0.22	-0.22

MEAN VALUE	NO. OF PEAKS	RMS
WAVEHT	0	0.00
FITCH	0	1.36
ROLL	45	2.48
UROWAC	122	0.10
USTRNA	216	0.13
VEGAC	124	0.06
TRCGAC	59	0.05
LNCGAC	136	0.07
	0	0.00

SEAWORTHINESS TEST RESULTS IN LOW SEA STATE 4 (26 FEB 1980)

RUN 6 S. BEAM SEA, WPB, APPROX. 15 KNOTS

226W06

	CHRONOLOGICAL OUTPUT? 1 16			AVERAGE			AVE 1/3			AVE 1/10			EXTREME		
	PK	TR	TR	PK	TR	TR	PK	TR	TR	PK	TR	TR	PK	TR	TR
PITCH	3.16	1.64	0.80	0.91	1.87	2.88	0.49	1.06	1.17	-1.18	-2.03	2.82	-2.67	3.96	-3.86
ROLL	-0.16	-1.04	-1.30	-1.89	-1.94	-1.66	-0.60	-1.35	5.85	-5.84	10.35	-11.22	13.19	-15.69	-23.39
VCGAC	0.15	0.17	0.22	0.27	0.26	0.26	0.27	0.27	0.15	-0.17	-0.22	0.27	-0.32	0.37	-0.37
TRCGAC	0.15	0.15	0.26	0.63	-0.03	2.10	1.92	-0.62	0.06	-0.07	0.08	0.38	-0.35	0.59	-0.60
LMEGAC	-0.72	-0.29	-1.90	-2.56	-1.09	-2.13	-1.73	-1.97	0.06	-0.07	0.08	0.10	-0.12	0.12	-0.15
CHRONOLOGICAL OUTPUT? 2 16															
ROLL	0.78	10.50	5.66	3.22	4.10	8.84	11.52	6.05	3.96	3.52	3.39	3.16	2.96	2.88	2.77
PITCH	-3.47	-5.08	-5.91	-5.42	0.54	-12.06	-15.82	-7.62	-3.86	-3.65	-3.17	-2.98	-2.77	-2.67	-2.59
VCGAC	0.14	0.18	0.15	0.20	0.27	0.37	0.18	0.23	2.49	2.47	2.44	2.39	2.29	2.25	2.23
TRCGAC	-0.19	-0.08	-0.24	-0.14	-0.28	-0.36	-0.37	-0.24	-2.26	-2.23	-2.21	-2.18	-2.13	-2.12	-2.08
LMEGAC	-10.74	-2.83	-5.32	-5.96	-23.39	-7.62	-7.86	-3.22	RANKED OUTPUT? 2 16						
CHRONOLOGICAL OUTPUT? 3 16															
ROLL	0.14	0.18	0.15	0.20	0.27	0.37	0.18	0.23	16.80	15.19	15.09	14.79	13.38	11.67	11.52
PITCH	-0.21	-0.13	-0.28	-0.29	-0.28	-0.17	-0.27	-0.37	-23.39	-17.97	-16.02	-16.02	-15.82	-14.99	-14.16
VCGAC	0.08	0.20	0.20	0.23	0.07	0.15	0.20	0.26	11.04	10.99	10.79	10.60	10.50	10.30	10.25
TRCGAC	-0.34	-0.29	-0.24	-0.15	-0.08	-0.14	-0.33	-0.60	-12.60	-12.21	-12.16	-12.06	-11.82	-10.99	-10.94
LMEGAC	0.10	0.11	0.08	0.05	0.24	0.13	0.05	0.26	RANKED OUTPUT? 3 16						
CHRONOLOGICAL OUTPUT? 4 16															
ROLL	0.10	0.11	0.08	0.05	0.24	0.13	0.05	0.26	0.37	0.33	0.32	0.32	0.28	0.28	0.27
PITCH	-0.23	-0.07	-0.06	-0.22	-0.35	-0.07	-0.19	-0.22	-0.37	-0.37	-0.37	-0.36	-0.35	-0.33	-0.33
VCGAC	0.39	0.14	0.34	0.16	0.17	0.03	0.19	0.59	0.27	0.26	0.26	0.26	0.25	0.25	0.24
TRCGAC	-0.34	-0.29	-0.24	-0.15	-0.08	-0.14	-0.33	-0.60	-0.33	-0.32	-0.31	-0.31	-0.30	-0.30	-0.29
LMEGAC	0.05	0.06	0.05	0.05	0.08	0.05	0.06	0.08	RANKED OUTPUT? 4 16						
CHRONOLOGICAL OUTPUT? 5 16															
ROLL	0.05	0.06	0.05	0.05	0.08	0.05	0.06	0.08	0.59	0.45	0.44	0.39	0.38	0.37	0.34
PITCH	-0.08	-0.09	-0.10	-0.06	-0.09	-0.10	-0.05	-0.15	-0.60	-0.35	-0.34	-0.34	-0.33	-0.33	-0.32
VCGAC	0.07	0.05	0.07	0.04	0.05	0.06	0.06	0.12	0.32	0.31	0.31	0.29	0.26	0.26	0.25
TRCGAC	-0.10	-0.07	-0.14	-0.06	-0.10	-0.11	-0.06	-0.05	-0.31	-0.29	-0.29	-0.25	-0.25	-0.25	-0.25
LMEGAC	0.02	0.02	0.02	0.03	0.03	0.03	0.03	0.03	RANKED OUTPUT? 5 16						
MEAN VALUE NO. OF PEAKS RMS															
PITCH	0.02	143	1.05												
ROLL	0.02	103	5.47												
VCGAC	0.00	203	0.12												
TRCGAC	0.00	119	0.13												
LMEGAC	0.00	64	0.03												

SEAWORTHINESS TEST RESULTS IN LOW SEA STATE 4 (26 FEB 1980)

RUN 7 HEAD SEA, SES, APPROX. 15 KNOTS

226S07

	CHRONOLOGICAL OUTPUT?		AVERAGE		AVE 1/3		AVE 1/10		EXTREME							
	PK	TR	PK	TR	PK	TR	PK	TR	PK	TR						
PITCH	0.67	0.72	0.37	0.80	0.59	1.56	1.32	0.73	1.06	-1.09	1.65	-1.66	2.25	-2.03	2.39	-2.25
ROLL	-0.67	-0.46	-0.94	-0.67	-0.81	-0.78	-1.17	-0.42	1.64	-1.78	2.78	-2.87	3.64	-3.55	5.66	-4.69
VBOMAC	0.27	0.25	0.41	0.51	0.56	0.70	0.94	0.99	0.27	-0.25	0.54	-0.20	0.73	-0.27	1.03	-0.42
VSTRNA	0.75	0.70	0.85	0.86	0.60	0.52	0.55	0.52	0.33	-0.13	0.54	-0.20	0.73	-0.27	1.03	-0.42
VCGAC	-1.17	-1.53	-0.78	-1.29	-0.60	-2.12	-1.48	-0.81	0.19	-0.11	0.26	-0.17	0.36	-0.24	0.68	-0.39
TRCGAC	0.05	0.05	-0.11	0.07	-0.14	0.09	-0.17	0.10	0.05	-0.11	0.07	-0.14	0.09	-0.17	0.10	-0.18

	RANKED OUTPUT?		AVERAGE		AVE 1/3		AVE 1/10		EXTREME							
	PK	TR	PK	TR	PK	TR	PK	TR	PK	TR						
PITCH	2.05	5.66	-1.07	2.25	0.45	3.61	0.78	2.05	2.39	2.31	2.00	1.99	1.64	1.56	1.33	1.33
ROLL	-1.51	-4.69	-2.44	-2.25	-0.63	-2.05	-2.83	-0.34	-2.25	-2.12	-2.03	-1.74	-1.71	-1.61	-1.53	-1.53
PITCH	4.05	1.86	2.54	3.81	2.44	1.51	3.03	3.22	1.32	1.32	1.25	1.25	1.19	1.17	1.14	1.14
ROLL	-2.88	-2.00	-2.78	-3.08	-2.05	-1.66	-2.59	-3.03	-1.50	-1.48	-1.48	-1.48	-1.29	-1.24	-1.24	-1.24

	RANKED OUTPUT?		AVERAGE		AVE 1/3		AVE 1/10		EXTREME						
	PK	TR	PK	TR	PK	TR	PK	TR	PK	TR					
VBOMAC	0.08	0.55	0.36	0.42	0.41	0.44	0.13	0.28	5.66	4.05	3.81	3.61	3.22	3.17	3.12
ROLL	-0.26	-0.55	-0.54	-0.83	0.06	-0.52	-0.07	-0.08	-4.69	-4.49	-3.52	-3.47	-3.37	-3.17	-3.17
VBOMAC	0.37	0.00	0.57	0.23	0.37	0.29	0.39	0.28	3.08	3.03	2.93	2.83	2.78	2.73	2.69
ROLL	-0.46	-0.46	-0.68	-0.21	-0.54	-0.50	-0.47	0.07	-3.17	-3.12	-3.08	-3.08	-3.03	-2.98	-2.88

	RANKED OUTPUT?		AVERAGE		AVE 1/3		AVE 1/10		EXTREME						
	PK	TR	PK	TR	PK	TR	PK	TR	PK	TR					
USTRNA	-0.05	0.42	0.79	0.50	0.35	0.42	0.31	0.24	0.99	0.86	0.73	0.72	0.68	0.67	0.63
ROLL	-0.29	-0.33	-0.19	-0.15	-0.16	-0.11	-0.21	-0.33	-0.94	-0.93	-0.90	-0.85	-0.81	-0.80	-0.80
USTRNA	0.52	0.50	0.33	0.35	0.18	0.33	0.11	0.43	0.62	0.60	0.60	0.59	0.57	0.57	0.57
ROLL	-0.09	-0.20	-0.11	-0.15	-0.19	-0.06	-0.08	-0.08	-0.80	-0.76	-0.75	-0.75	-0.73	-0.73	-0.72

	RANKED OUTPUT?		AVERAGE		AVE 1/3		AVE 1/10		EXTREME						
	PK	TR	PK	TR	PK	TR	PK	TR	PK	TR					
VCGAC	0.17	0.10	0.19	0.15	0.23	0.12	0.24	0.19	1.03	0.91	0.87	0.83	0.81	0.81	0.80
ROLL	-0.11	-0.13	-0.21	-0.07	-0.11	-0.07	-0.17	-0.15	-0.42	-0.34	-0.33	-0.33	-0.32	-0.30	-0.29
VCGAC	0.14	0.17	0.18	0.35	0.13	0.16	0.23	0.15	0.79	0.79	0.76	0.74	0.74	0.73	0.72
ROLL	-0.17	-0.16	-0.07	-0.08	-0.15	-0.07	-0.12	-0.10	-0.28	-0.28	-0.28	-0.27	-0.26	-0.25	-0.24

	RANKED OUTPUT?		AVERAGE		AVE 1/3		AVE 1/10		EXTREME						
	PK	TR	PK	TR	PK	TR	PK	TR	PK	TR					
TRCGAC	0.04	0.09	0.05	0.05	0.02	0.08	0.04	0.03	0.68	0.63	0.50	0.46	0.43	0.38	0.36
ROLL	-0.09	-0.15	-0.09	-0.14	-0.12	-0.14	-0.15	-0.10	-0.39	-0.37	-0.33	-0.28	-0.28	-0.25	-0.25
TRCGAC	0.05	0.05	0.02	0.03	0.03	0.07	0.04	0.06	0.35	0.34	0.33	0.32	0.31	0.31	0.30
ROLL	-0.07	-0.12	-0.08	-0.13	-0.11	-0.08	-0.09	-0.11	-0.24	-0.24	-0.24	-0.23	-0.21	-0.21	-0.20

	MEAN VALUE	NO. OF PEAKS	RMS
WAVENT	0.03	0	0.00
PITCH	-0.00	42	0.78
ROLL	-0.06	108	1.43
VBOMAC	0.03	399	0.18
VSTRNA	0.03	290	0.12
VCGAC	0.04	236	0.07
TRCGAC	-0.03	107	0.04
LMCGAC	-0.04	0	0.00

SEAWORTHINESS TEST RESULTS IN LOW SEA STATE 4 (26 FEB 1980)

RUN 7 HEAD SEA, WPB, APPROX. 15 KNOTS

226W07

CHRONOLOGICAL OUTPUT? 1 16  
 FITCH 1.63 2.36 0.91 1.37 1.12 2.05 1.27 1.58  
 -0.98 -1.68 -1.06 -0.75 -1.71 -0.93 -1.29 -1.29  
 PITCH 2.54 1.22 2.05 1.79 0.63 1.24 1.55 1.81  
 -2.07 -1.55 -1.24 -2.12 -2.21 -1.29 -1.69 -1.45

AVERAGE AVE 1/3 AVE 1/10 EXTREME  
 PK TR PK TR PK TR PK TR  
 FITCH 1.19 -1.20 1.87 -1.88 2.29 -2.52 2.69 -3.92  
 ROLL 2.82 -2.57 5.11 -5.02 6.72 -7.49 7.67 -9.77  
 VCGAC 0.16 -0.18 0.23 -0.28 0.27 -0.34 0.33 -0.40  
 TRCGAC 0.09 -0.09 0.14 -0.14 0.19 -0.17 0.23 -0.21  
 LNCGAC 0.06 -0.09 0.09 -0.12 0.13 -0.16 0.62 -0.21

CHRONOLOGICAL OUTPUT? 2 16  
 ROLL 2.78 2.29 0.68 2.20 3.17 4.93  
 -2.69 -1.71 -3.66 -1.86 -2.10 -1.46 -4.00 -0.24  
 ROLL 2.49 4.59 3.12 3.86 5.47 5.71 4.05 6.15  
 -4.25 -0.88 -0.34 -1.27 -6.98 0.68 -2.00

RANKED OUTPUT? 1 16  
 PITCH 2.69 2.60 2.54 2.51 2.46 2.43 2.36 2.33  
 -3.92 -3.21 -2.91 -2.85 -2.69 -2.67 -2.59 -2.54  
 FITCH 2.31 2.26 2.23 2.21 2.15 2.13 2.12 2.10  
 -2.49 -2.44 -2.41 -2.28 -2.21 -2.20 -2.15 -2.12

CHRONOLOGICAL OUTPUT? 3 16  
 VCGAC 0.07 0.25 0.21 0.20 0.19 0.20 0.05 0.24  
 -0.05 -0.32 -0.16 -0.36 -0.20 -0.30 -0.12 -0.16  
 VCGAC 0.22 0.07 0.24 0.25 0.24 0.29 0.33 0.20  
 -0.25 -0.24 -0.17 -0.25 -0.37 -0.17 -0.37 -0.24

RANKED OUTPUT? 2 16  
 ROLL 7.67 7.67 7.52 7.32 6.15 6.15 6.15 5.96  
 -9.77 -9.03 -8.40 -7.52 -7.08 -6.98 -6.79 -5.96  
 ROLL 5.91 5.71 5.62 5.57 5.57 5.47 5.08 4.93  
 -5.86 -5.62 -5.62 -5.62 -5.27 -4.65 -4.59 -4.39

CHRONOLOGICAL OUTPUT? 4 16  
 TRCGAC 0.03 0.13 0.05 0.08 0.10 0.08 0.08 0.10  
 -0.10 -0.07 -0.06 -0.04 -0.07 -0.03 -0.13 -0.12  
 TRCGAC 0.06 0.14 0.10 0.06 0.08 0.09 0.09 0.20  
 -0.09 -0.08 -0.01 -0.11 -0.12 -0.08 -0.16 -0.18

RANKED OUTPUT? 3 16  
 VCGAC 0.33 0.33 0.33 0.31 0.30 0.30 0.28 0.28  
 -0.40 -0.39 -0.37 -0.37 -0.37 -0.36 -0.36 -0.36  
 VCGAC 0.28 0.28 0.27 0.27 0.27 0.26 0.26 0.25  
 -0.35 -0.34 -0.34 -0.33 -0.33 -0.33 -0.32 -0.32

CHRONOLOGICAL OUTPUT? 5 16  
 LNCGAC 0.05 0.08 0.05 0.06 0.05 0.04 0.06 0.04  
 -0.09 -0.14 -0.09 -0.10 -0.11 -0.06 -0.12 -0.07  
 LNCGAC 0.04 0.09 0.05 0.03 0.02 0.06 0.06 0.05  
 -0.10 -0.15 -0.10 -0.15 -0.20 -0.09 -0.08 -0.06

RANKED OUTPUT? 4 16  
 TRCGAC 0.23 0.21 0.21 0.20 0.20 0.19 0.19 0.18  
 -0.21 -0.21 -0.18 -0.18 -0.17 -0.16 -0.16 -0.16  
 TRCGAC 0.18 0.17 0.16 0.15 0.15 0.14 0.14 0.14  
 -0.15 -0.15 -0.15 -0.14 -0.14 -0.14 -0.14 -0.14

MEAN VALUE NO. OF PEAKS RMS  
 FITCH 0.00 197 0.93  
 ROLL 0.04 99 2.72  
 VCGAC 0.00 247 0.12  
 TRCGAC -0.00 104 0.06  
 LNCGAC -0.00 149 0.04

RANKED OUTPUT? 5 16  
 LNCGAC 0.62 0.10 0.10 0.09 0.09 0.09 0.09 0.09  
 -0.21 -0.20 -0.17 -0.17 -0.16 -0.15 -0.15 -0.14  
 LNCGAC 0.09 0.09 0.09 0.09 0.09 0.08 0.08 0.08  
 -0.14 -0.14 -0.14 -0.14 -0.14 -0.14 -0.14 -0.14

RUN 8 P. QUARTERING SEA, SES, APPROX. 17 KNOTS

	CHRONOLOGICAL OUTPUT?		AVERAGE		AVE 1/3		AVE 1/10		EXTREME	
	PK	TR	PK	TR	PK	TR	PK	TR	PK	TR
PITCH	2.80	2.88	1.27	2.57	1.17	2.10	2.10	2.10	0.39	0.39
ROLL	0.02	0.39	-1.51	-1.64	-0.07	-1.20	-0.65	-0.72	0.57	0.57
VSTRNA	2.39	0.37	0.85	1.11	1.74	1.43	1.46	1.97	0.70	0.26
VCGAC	-1.76	-1.17	-1.35	-0.28	-2.21	-0.67	-1.03	-2.05	0.38	0.22
TRCGAC									0.11	-0.20

	RANKED OUTPUT?		AVERAGE		AVE 1/3		AVE 1/10		EXTREME	
	PK	TR	PK	TR	PK	TR	PK	TR	PK	TR
PITCH	4.59	4.39	4.17	4.13	3.42	3.30	3.19	3.12	4.59	5.68
ROLL	-5.68	-4.56	-3.76	-3.27	-3.24	-3.22	-3.09	-3.08	7.13	7.91
VSTRNA	3.03	3.03	2.88	2.86	2.82	2.80	2.80	2.75	0.57	0.57
VCGAC	-3.06	-3.01	-3.01	-2.64	-2.60	-2.60	-2.60	-2.56	0.70	0.26
TRCGAC									0.38	0.22

	RANKED OUTPUT?		AVERAGE		AVE 1/3		AVE 1/10		EXTREME	
	PK	TR	PK	TR	PK	TR	PK	TR	PK	TR
PITCH	7.13	6.15	5.37	5.32	4.98	4.83	4.83	4.74	4.59	5.68
ROLL	-7.91	-7.32	-6.05	-6.05	-5.96	-5.32	-4.98	-4.93	7.13	7.91
VSTRNA	4.39	4.39	4.00	3.91	3.56	3.37	3.22	3.22	0.57	0.57
VCGAC	-4.93	-4.93	-4.93	-4.88	-4.74	-4.64	-4.54	-4.54	0.70	0.26
TRCGAC									0.38	0.22

	RANKED OUTPUT?		AVERAGE		AVE 1/3		AVE 1/10		EXTREME	
	PK	TR	PK	TR	PK	TR	PK	TR	PK	TR
PITCH	0.57	0.57	0.55	0.54	0.54	0.54	0.52	0.52	0.57	0.57
ROLL	-1.16	-1.01	-0.91	-0.90	-0.81	-0.75	-0.72	-0.72	0.57	0.57
VSTRNA	0.50	0.47	0.46	0.46	0.44	0.42	0.41	0.41	0.57	0.57
VCGAC	-0.70	-0.65	-0.65	-0.63	-0.63	-0.62	-0.62	-0.62	0.57	0.57
TRCGAC									0.57	0.57

	RANKED OUTPUT?		AVERAGE		AVE 1/3		AVE 1/10		EXTREME	
	PK	TR	PK	TR	PK	TR	PK	TR	PK	TR
PITCH	0.70	0.63	0.60	0.59	0.59	0.57	0.57	0.55	0.70	0.70
ROLL	-0.26	-0.24	-0.24	-0.23	-0.22	-0.21	-0.20	-0.20	0.70	0.70
VSTRNA	0.52	0.51	0.51	0.51	0.48	0.47	0.46	0.46	0.70	0.70
VCGAC	-0.20	-0.18	-0.18	-0.17	-0.17	-0.16	-0.16	-0.16	0.70	0.70
TRCGAC									0.70	0.70

	RANKED OUTPUT?		AVERAGE		AVE 1/3		AVE 1/10		EXTREME	
	PK	TR	PK	TR	PK	TR	PK	TR	PK	TR
PITCH	0.38	0.36	0.28	0.26	0.26	0.26	0.25	0.24	0.38	0.38
ROLL	-0.29	-0.28	-0.23	-0.22	-0.21	-0.21	-0.19	-0.18	0.38	0.38
VSTRNA	0.24	0.24	0.23	0.23	0.22	0.22	0.21	0.21	0.38	0.38
VCGAC	-0.17	-0.16	-0.16	-0.16	-0.15	-0.15	-0.15	-0.14	0.38	0.38
TRCGAC									0.38	0.38

	RANKED OUTPUT?		AVERAGE		AVE 1/3		AVE 1/10		EXTREME	
	PK	TR	PK	TR	PK	TR	PK	TR	PK	TR
PITCH	0.17	0.13	0.11	0.11	0.11	0.10	0.10	0.10	0.17	0.17
ROLL	-0.23	-0.21	-0.21	-0.20	-0.20	-0.20	-0.19	-0.18	0.17	0.17
VSTRNA	0.09	0.08	0.08	0.08	0.08	0.08	0.08	0.08	0.17	0.17
VCGAC	-0.18	-0.17	-0.17	-0.16	-0.16	-0.16	-0.16	-0.15	0.17	0.17
TRCGAC									0.17	0.17

	MEAN VALUE		NO. OF PEAKS	RMS
	PK	TR		
WAVENT	0.03	0.03	0	0.00
PITCH	-0.01	1.47	111	2.06
ROLL	-0.38	0.17	105	0.09
VSTRNA	0.02	1.68	125	0.06
VCGAC	0.04	0.04	90	0.05
TRCGAC	-0.04	0.05	97	0.00
LNCGAC	-0.06	-0.06	0	0.00

SEAWORTHINESS TEST RESULTS IN LOW SEA STATE 4 (26 FEB 1980)

RUN 8 P. QUARTERING SEA, WPB, APPROX. 17 KNOTS

226W08

CHRONOLOGICAL OUTPUT? 1 16		AVERAGE		AVE 1/3		AVE 1/10		EXTREME	
		PK	TR	PK	TR	PK	TR	PK	TR
FITCH	1.42 2.28 2.64 0.46 1.35 0.05 2.33 0.81	1.49	-1.53	2.52	-2.58	3.08	-3.44	3.69	-4.65
	-1.27 -1.06 -0.07 -0.72 -1.74 -1.64 -1.01 -1.45	5.22	-5.35	11.60	-10.37	15.79	-14.17	22.17	-18.41
FITCH	1.25 1.55 1.40 1.90 1.03 0.93 3.69 3.55	0.14	-0.15	0.21	-0.23	0.26	-0.29	0.37	-0.37
	-1.25 -1.32 -1.46 -1.38 -2.08 -2.39 -4.00 -1.22	TRCGAC	0.15	-0.13	0.25	-0.25	0.34	-0.35	0.46
		LNGCAG	0.12	-0.01	0.13	-0.03	0.14	-0.06	0.15
CHRONOLOGICAL OUTPUT? 2 16		RANKED OUTPUT? 1 16							
ROLL	10.99 2.93 -4.00 3.86 12.16 1.86 2.54 2.34	FITCH	3.69	3.55	3.27	3.16	3.02	3.04	2.99
	-8.64 -5.18 -11.72 -7.71 2.25 -4.79 -5.76 -4.64		-4.65	-4.04	-4.00	-3.81	-3.69	-3.52	-3.37
ROLL	10.94 2.29 13.57 3.27 3.32 7.52 7.62 3.56	FITCH	2.98	2.96	2.77	2.77	2.77	2.77	2.75
	-11.08 0.15 -11.04 -9.08 -0.15 -7.57 -5.27 -6.54		-3.06	-2.85	-2.72	-2.70	-2.65	-2.64	-2.59
CHRONOLOGICAL OUTPUT? 3 16		RANKED OUTPUT? 2 16							
VCGAC	0.20 0.37 0.20 0.21 0.15 0.17 0.16 0.08	ROLL	22.17	17.92	17.43	16.50	13.96	13.92	13.38
	-0.06 0.11 -0.19 -0.13 -0.11 -0.19 -0.03 -0.11		-18.41	-18.21	-16.31	-14.45	-12.99	-12.60	-11.72
VCGAC	0.07 0.15 0.19 0.23 0.32 0.24 0.37 0.09	ROLL	13.38	12.60	12.30	12.16	12.01	11.87	11.47
	-0.14 -0.03 0.02 0.08 -0.08 0.10 0.01 -0.11		-11.08	-11.04	-10.64	-10.50	-10.45	-10.16	-9.86
CHRONOLOGICAL OUTPUT? 4 16		RANKED OUTPUT? 3 16							
TRCGAC	0.14 0.20 0.22 0.02 -0.05 0.14 0.12 0.12	VCGAC	0.37	0.37	0.32	0.22	0.26	0.26	0.24
	-0.19 -0.10 0.04 -0.18 -0.16 -0.24 -0.03 -0.07		-0.37	-0.34	-0.32	-0.29	-0.29	-0.29	-0.29
TRCGAC	0.09 0.31 0.07 0.28 0.25 0.11 0.21 0.12	VCGAC	0.24	0.24	0.24	0.24	0.24	0.24	0.23
	-0.09 -0.08 -0.28 -0.14 -0.28 -0.08 -0.15 -0.22		-0.28	-0.28	-0.27	-0.26	-0.26	-0.26	-0.25
CHRONOLOGICAL OUTPUT? 5 16		RANKED OUTPUT? 4 16							
LNGCAG	0.10 0.11 0.10 0.11 0.14 0.14 0.12 0.11	TRCGAC	0.46	0.41	0.36	0.35	0.32	0.31	0.29
	0.00 0.00 -0.00 -0.02 -0.09 0.02 -0.01 -0.01		-0.44	-0.42	-0.37	-0.35	-0.34	-0.31	-0.31
LNGCAG	0.10 0.12 0.12 0.12 0.11 0.10 0.13 0.12	TRCGAC	0.28	0.26	0.26	0.25	0.25	0.25	0.25
	-0.00 -0.01 -0.00 0.02 -0.00 0.00 -0.01 0.02		-0.30	-0.28	-0.28	-0.27	-0.27	-0.24	-0.23
MEAN VALUE		NO. OF PEAKS		RMS					
FITCH	-0.01	130	1.29						
ROLL	0.11	93	5.69						
VCGAC	-0.00	176	0.11						
TRCGAC	0.00	98	0.12						
LNGCAG	0.06	50	0.03						

SEAWORTHINESS TEST RESULTS IN LOW SEA STATE 4 (26 FEB 1980)

RUN 9 S. BOW SEA, SES, APPROX. 16 KNOTS

226S09

	CHRONOLOGICAL OUTPUT? 2 16				AVERAGE				AVE 1/3				EXTREME			
	PK	TR	PK	TR	PK	TR	PK	TR	PK	TR	PK	TR	PK	TR	PK	TR
PITCH	2.59	2.20	-1.04	1.82	1.81	3.91	-0.44	1.16	1.77	-1.92	2.96	-3.29	3.91	-4.48	4.79	-6.35
ROLL	-3.17	-2.65	-2.56	-2.72	-1.60	-2.98	-4.41	-2.46	1.96	-1.65	3.34	-2.83	4.48	-3.71	6.40	-4.30
VBOWAC	0.26	-0.24	0.39	-0.45	0.49	-0.63	0.98	-0.45	0.26	-0.24	0.39	-0.45	0.49	-0.63	1.12	-0.98
USTRNA	2.82	1.89	1.09	1.38	-0.34	1.19	1.90	1.61	0.24	-0.13	0.38	-0.21	0.53	-0.29	0.81	-0.45
VCGAC	-0.05	0.37	-1.60	-0.55	-1.35	-2.10	-0.36	-0.90	0.17	-0.11	0.22	-0.17	0.26	-0.21	0.37	-0.24
TRCGAC	0.06	-0.13	0.10	-0.18	0.10	-0.18	0.12	-0.22	0.06	-0.13	0.10	-0.18	0.12	-0.22	0.16	-0.27

	RANKED OUTPUT? 2 16							
PITCH	4.79	3.99	3.91	3.68	3.17	2.93	2.88	2.85
ROLL	-6.35	-4.41	-4.35	-3.84	-3.43	-3.39	-3.27	-3.17
PITCH	2.82	2.75	2.72	2.67	2.65	2.64	2.59	2.43
ROLL	-3.14	-2.98	-2.93	-2.83	-2.73	-2.72	-2.65	-2.65

	RANKED OUTPUT? 3 16							
ROLL	6.40	4.83	4.69	4.64	4.20	4.10	4.10	4.10
VBOWAC	-4.30	-4.20	-4.05	-4.00	-3.81	-3.52	-3.47	-3.27
ROLL	4.00	3.76	3.76	3.76	3.61	3.56	3.47	3.32
VBOWAC	-3.27	-3.17	-3.12	-3.08	-2.93	-2.78	-2.78	-2.78

	RANKED OUTPUT? 4 16							
USTRNA	1.12	0.62	0.54	0.54	0.52	0.52	0.50	0.50
VCGAC	-0.98	-0.83	-0.76	-0.75	-0.73	-0.72	-0.67	-0.65
USTRNA	0.49	0.49	0.47	0.46	0.46	0.44	0.44	0.44
VCGAC	-0.65	-0.65	-0.65	-0.63	-0.63	-0.62	-0.60	-0.59

	RANKED OUTPUT? 5 16							
USTRNA	0.81	0.69	0.68	0.62	0.59	0.59	0.55	0.55
VCGAC	-0.45	-0.42	-0.40	-0.33	-0.31	-0.30	-0.30	-0.30
USTRNA	0.55	0.51	0.51	0.51	0.50	0.46	0.46	0.45
VCGAC	-0.30	-0.29	-0.28	-0.28	-0.26	-0.25	-0.24	-0.24

	RANKED OUTPUT? 6 16							
VCGAC	0.37	0.33	0.31	0.29	0.24	0.24	0.24	0.24
TRCGAC	-0.24	-0.24	-0.23	-0.22	-0.22	-0.22	-0.21	-0.21
VCGAC	0.23	0.23	0.23	0.22	0.22	0.21	0.21	0.21
TRCGAC	-0.21	-0.20	-0.20	-0.19	-0.18	-0.18	-0.18	-0.17

	RANKED OUTPUT? 7 16							
TRCGAC	0.15	0.14	0.14	0.13	0.12	0.12	0.12	0.11
TRCGAC	-0.27	-0.27	-0.23	-0.22	-0.22	-0.21	-0.21	-0.21
TRCGAC	0.11	0.11	0.11	0.11	0.10	0.10	0.10	0.10
TRCGAC	-0.20	-0.20	-0.20	-0.20	-0.20	-0.19	-0.19	-0.19

	MEAN VALUE	NO. OF PEAKS	RMS
HAWEHT	0.04	0	0.00
PITCH	0.07	59	1.55
ROLL	0.21	108	1.56
VBOWAC	0.03	290	0.17
USTRNA	0.03	211	0.09
VCGAC	0.04	127	0.06
TRCGAC	-0.03	138	0.06
LMCGAC	-0.05	0	0.00

SEAWORTHINESS TEST RESULTS IN LOW SEA STATE 4 (26 FEB 1980)

RUN 9 S. BOW SEA, WPB, APPROX. 16 KNOTS

226W09

CHRONOLOGICAL OUTPUT? 1 16  
 FITCH 0.54 0.63 1.58 1.14 3.27 3.96 1.94 -0.29  
 -1.43 -0.70 -0.67 -1.11 -0.16 -1.12 -2.56 -2.12  
 PITCH 0.60 1.03 0.94 1.64 2.65 2.38 2.23 1.68  
 -1.50 -2.02 -2.03 -1.64 -0.10 -0.05 -0.67 -2.64

CHRONOLOGICAL OUTPUT? 2 16  
 ROLL 1.32 2.44 6.59 7.52 -0.93 10.01 2.98 0.44  
 -0.44 -1.56 -3.86 2.29 -9.23 -8.30 -1.12 -7.08  
 ROLL -0.24 6.01 1.76 1.17 7.18 -1.95 -1.03 6.35  
 -8.11 -5.91 0.20 0.05 -4.25 -4.44 -13.57 -4.79

CHRONOLOGICAL OUTPUT? 3 16  
 VCGAC 0.16 0.07 0.16 0.13 0.16 0.29 0.34 0.14  
 -0.24 -0.11 -0.13 -0.14 -0.13 -0.26 -0.42 -0.25  
 VCGAC 0.11 0.28 0.16 0.20 0.10 0.20 0.20 0.21  
 -0.12 -0.28 -0.17 -0.15 -0.14 -0.18 -0.28 -0.25

CHRONOLOGICAL OUTPUT? 4 16  
 TRCGAC 0.07 0.09 0.07 0.04 0.06 0.31 0.30 0.11  
 -0.05 -0.07 -0.16 -0.28 -0.16 -0.05 -0.07 -0.04  
 TRCGAC 0.06 0.08 0.26 0.20 0.16 0.02 0.08 0.10  
 -0.22 -0.13 -0.06 -0.09 -0.05 -0.21 -0.10 -0.08

CHRONOLOGICAL OUTPUT? 5 16  
 LNCGAC 0.08 0.13 0.12 0.05 0.05 0.05 0.05 0.07  
 -0.05 -0.10 -0.16 -0.05 -0.05 -0.08 -0.08 -0.06  
 LNCGAC 0.09 0.12 0.11 0.07 0.07 0.06 0.09 0.09  
 -0.06 -0.13 -0.14 -0.08 -0.07 -0.07 -0.13 -0.10

MEAN VALUE NO. OF PEAKS RMS  
 PITCH 0.00 181 1.52  
 ROLL -0.01 94 3.61  
 VCGAC 0.01 224 0.14  
 TRCGAC -0.00 129 0.09  
 LNCGAC -0.00 130 0.04

AVERAGE AVE 1/3 TR PK AVE 1/10 TR PK EXTREME TR  
 PITCH 1.40 -1.54 2.39 -2.74 3.00 -3.52 4.51 -4.56  
 ROLL 3.33 -3.55 6.84 -7.30 8.73 -10.17 10.01 -13.57  
 VCGAC 0.19 -0.20 0.28 -0.32 0.34 -0.42 0.47 -0.59  
 TRCGAC 0.11 -0.12 0.21 -0.19 0.29 -0.24 0.37 -0.28  
 LNCGAC 0.06 -0.09 0.09 -0.13 0.10 -0.17 0.13 -0.23

RANKED OUTPUT? 1 16  
 PITCH 4.51 3.96 3.27 3.17 3.14 3.11 3.09 3.08  
 -4.56 -4.44 -4.38 -3.99 -3.69 -3.66 -3.65 -3.47  
 PITCH 3.08 3.01 2.82 2.75 2.65 2.59 2.46 2.46  
 -3.29 -3.27 -3.24 -3.21 -3.17 -3.17 -3.16 -3.08

RANKED OUTPUT? 2 16  
 ROLL 10.01 9.62 9.57 9.28 8.98 8.15 7.81 7.67  
 -13.57 -10.55 -10.45 -9.96 -9.86 -9.37 -9.33 -9.23  
 ROLL 7.52 7.47 7.18 7.03 6.93 6.79 6.74 6.59  
 -9.18 -8.94 -8.30 -8.11 -8.11 -7.57 -7.08 -6.98

RANKED OUTPUT? 3 16  
 VCGAC 0.47 0.46 0.36 0.36 0.36 0.36 0.36 0.35  
 -0.59 -0.58 -0.50 -0.47 -0.46 -0.44 -0.44 -0.43  
 VCGAC 0.34 0.33 0.33 0.33 0.33 0.33 0.33 0.32  
 -0.42 -0.40 -0.40 -0.39 -0.38 -0.38 -0.37 -0.37

RANKED OUTPUT? 4 16  
 TRCGAC 0.37 0.34 0.32 0.31 0.30 0.30 0.28 0.27  
 -0.28 -0.26 -0.25 -0.25 -0.24 -0.23 -0.23 -0.22  
 TRCGAC 0.26 0.25 0.24 0.24 0.24 0.23 0.23 0.23  
 -0.22 -0.22 -0.21 -0.21 -0.21 -0.20 -0.20 -0.20

RANKED OUTPUT? 5 16  
 LNCGAC 0.13 0.12 0.12 0.11 0.10 0.10 0.09 0.09  
 -0.23 -0.20 -0.20 -0.19 -0.18 -0.17 -0.17 -0.17  
 LNCGAC 0.09 0.09 0.09 0.09 0.09 0.09 0.09 0.09  
 -0.16 -0.15 -0.15 -0.15 -0.14 -0.14 -0.14 -0.13

RUN 10 FOLLOWING SEA, SES, APPROX. 17 KNOTS

	CHRONOLOGICAL OUTPUT*				AVERAGE				AVE 1/3				EXTREME			
	PK	TR	PK	TR	PK	TR	PK	TR	PK	TR	PK	TR	PK	TR	PK	TR
PITCH	1.32	2.08	2.47	0.86	-0.88	0.73	1.43	1.40	1.17	-1.19	2.14	-2.27	2.60	-3.09	2.80	-4.07
ROLL	-0.85	-0.42	-0.59	-0.29	-3.68	-1.92	-1.46	-1.77	2.98	-3.13	4.98	-4.87	6.24	-6.11	7.18	-6.84
VRWAC	0.18	0.18	0.18	0.18	0.13	0.28	0.21	0.13	0.17	-0.15	0.24	-0.24	0.30	-0.34	0.42	-0.73
VSTRNA	1.68	0.76	0.52	0.73	1.24	0.96	1.58	2.07	0.18	-0.09	0.25	-0.12	0.37	-0.16	0.52	-0.23
VEGAC	-2.07	-1.99	-2.52	-1.60	-0.83	-0.37	-0.60	-1.12	0.15	-0.09	0.18	-0.13	0.21	-0.16	0.22	-0.17
TRCGAC	-0.06	-0.13	-0.11	-0.16	-0.14	-0.08	-0.15	-0.11	0.06	-0.12	0.09	-0.15	0.12	-0.17	0.15	-0.19

	RANKED OUTPUT*				RANKED OUTPUT*				RANKED OUTPUT*							
	PK	TR	PK	TR	PK	TR	PK	TR	PK	TR	PK	TR	PK	TR		
ROLL	1.51	3.47	0.78	1.56	2.00	2.69	2.93	0.39	2.80	2.78	2.70	2.56	2.56	2.51	2.47	2.39
PITCH	-2.15	-1.76	-3.47	-2.83	-2.00	-1.86	-1.71	-2.49	-4.07	-3.68	-3.12	-3.04	-2.93	-2.64	-2.64	-2.60
VRWAC	0.18	0.16	0.18	0.18	0.13	0.28	0.21	0.13	2.34	2.23	2.20	2.12	2.08	2.07	2.07	2.07
VSTRNA	3.76	1.12	2.29	3.37	0.39	1.95	2.20	0.63	-2.52	-2.49	-2.46	-2.16	-2.07	-2.03	-2.02	-1.99
VEGAC	-3.81	-1.37	-1.71	-2.44	-1.07	-3.81	-2.00	-0.93	-5.62	-5.42	-5.32	-5.08	-5.08	-5.03	-5.03	-4.98

	RANKED OUTPUT*				RANKED OUTPUT*				RANKED OUTPUT*							
	PK	TR	PK	TR	PK	TR	PK	TR	PK	TR	PK	TR	PK	TR		
VRWAC	0.18	0.16	0.18	0.18	0.13	0.28	0.21	0.13	7.18	6.98	6.54	6.49	6.49	6.15	5.96	5.91
PITCH	-0.16	-0.28	-0.13	-0.18	-0.23	-0.18	-0.21	-0.13	-6.84	-6.79	-6.59	-6.45	-6.40	-6.25	-5.96	-5.62
VRWAC	0.18	0.16	0.18	0.18	0.13	0.28	0.21	0.13	5.76	5.62	5.57	5.57	5.57	5.52	5.42	5.42
VSTRNA	0.13	0.31	0.11	0.52	0.21	0.15	0.28	0.14	-5.62	-5.42	-5.32	-5.08	-5.08	-5.03	-5.03	-4.98
VEGAC	-0.16	-0.13	-0.15	-0.08	-0.13	-0.10	-0.13	-0.21	-0.28	-0.28	-0.26	-0.24	-0.24	-0.23	-0.23	-0.23

	RANKED OUTPUT*				RANKED OUTPUT*				RANKED OUTPUT*							
	PK	TR	PK	TR	PK	TR	PK	TR	PK	TR	PK	TR	PK	TR		
VSTRNA	0.20	0.18	0.11	0.12	0.18	0.13	0.13	0.12	0.42	0.34	0.31	0.29	0.29	0.29	0.28	0.28
PITCH	-0.07	-0.07	-0.09	-0.12	-0.08	-0.08	-0.09	-0.12	-0.73	-0.39	-0.34	-0.33	-0.31	-0.31	-0.29	-0.28
VRWAC	0.13	0.31	0.11	0.52	0.21	0.15	0.28	0.14	0.28	0.26	0.26	0.26	0.26	0.26	0.26	0.26
VSTRNA	0.13	0.31	0.11	0.52	0.21	0.15	0.28	0.14	0.28	0.26	0.26	0.26	0.26	0.26	0.26	0.26
VEGAC	-0.08	-0.08	-0.10	-0.10	-0.23	-0.06	-0.10	-0.11	-0.28	-0.28	-0.26	-0.24	-0.24	-0.23	-0.23	-0.23

	RANKED OUTPUT*				RANKED OUTPUT*				RANKED OUTPUT*							
	PK	TR	PK	TR	PK	TR	PK	TR	PK	TR	PK	TR	PK	TR		
VSTRNA	0.16	0.13	0.14	0.14	0.18	0.15	0.04	0.11	0.52	0.31	0.28	0.28	0.22	0.21	0.20	0.18
PITCH	-0.08	-0.08	-0.09	-0.09	-0.11	-0.07	-0.17	-0.16	-0.23	-0.13	-0.12	-0.12	-0.11	-0.11	-0.11	-0.10
VRWAC	0.13	0.31	0.11	0.52	0.21	0.15	0.28	0.14	0.28	0.26	0.26	0.26	0.26	0.26	0.26	0.26
VSTRNA	0.13	0.31	0.11	0.52	0.21	0.15	0.28	0.14	0.28	0.26	0.26	0.26	0.26	0.26	0.26	0.26
VEGAC	-0.09	-0.05	-0.08	-0.06	-0.14	-0.11	-0.07	-0.11	-0.10	-0.10	-0.10	-0.10	-0.09	-0.09	-0.08	-0.08

	RANKED OUTPUT*				RANKED OUTPUT*				RANKED OUTPUT*							
	PK	TR	PK	TR	PK	TR	PK	TR	PK	TR	PK	TR	PK	TR		
VSTRNA	0.03	0.03	0.04	0.05	0.04	0.04	0.04	0.05	0.22	0.21	0.20	0.19	0.18	0.18	0.17	0.16
PITCH	-0.11	-0.12	-0.08	-0.09	-0.12	-0.15	-0.11	-0.13	-0.17	-0.16	-0.15	-0.14	-0.13	-0.12	-0.11	-0.11
VRWAC	0.13	0.31	0.11	0.52	0.21	0.15	0.28	0.14	0.28	0.26	0.26	0.26	0.26	0.26	0.26	0.26
VSTRNA	0.13	0.31	0.11	0.52	0.21	0.15	0.28	0.14	0.28	0.26	0.26	0.26	0.26	0.26	0.26	0.26
VEGAC	-0.06	-0.13	-0.11	-0.16	-0.14	-0.08	-0.15	-0.11	-0.10	-0.10	-0.10	-0.10	-0.10	-0.09	-0.09	-0.09

	RANKED OUTPUT*				RANKED OUTPUT*				RANKED OUTPUT*							
	PK	TR	PK	TR	PK	TR	PK	TR	PK	TR	PK	TR	PK	TR		
VSTRNA	0.05	0.03	0.02	0.07	0.06	0.04	0.04	0.01	0.22	0.21	0.20	0.19	0.18	0.18	0.17	0.16
PITCH	-0.11	-0.12	-0.08	-0.09	-0.12	-0.15	-0.11	-0.13	-0.17	-0.16	-0.15	-0.14	-0.13	-0.12	-0.11	-0.11
VRWAC	0.13	0.31	0.11	0.52	0.21	0.15	0.28	0.14	0.28	0.26	0.26	0.26	0.26	0.26	0.26	0.26
VSTRNA	0.13	0.31	0.11	0.52	0.21	0.15	0.28	0.14	0.28	0.26	0.26	0.26	0.26	0.26	0.26	0.26
VEGAC	-0.06	-0.13	-0.11	-0.16	-0.14	-0.08	-0.15	-0.11	-0.10	-0.10	-0.10	-0.10	-0.10	-0.09	-0.09	-0.09

	RANKED OUTPUT*				RANKED OUTPUT*				RANKED OUTPUT*							
	PK	TR	PK	TR	PK	TR	PK	TR	PK	TR	PK	TR	PK	TR		
VSTRNA	0.05	0.03	0.02	0.07	0.06	0.04	0.04	0.01	0.22	0.21	0.20	0.19	0.18	0.18	0.17	0.16
PITCH	-0.11	-0.12	-0.08	-0.09	-0.12	-0.15	-0.11	-0.13	-0.17	-0.16	-0.15	-0.14	-0.13	-0.12	-0.11	-0.11
VRWAC	0.13	0.31	0.11	0.52	0.21	0.15	0.28	0.14	0.28	0.26	0.26	0.26	0.26	0.26	0.26	0.26
VSTRNA	0.13	0.31	0.11	0.52	0.21	0.15	0.28	0.14	0.28	0.26	0.26	0.26	0.26	0.26	0.26	0.26
VEGAC	-0.06	-0.13	-0.11	-0.16	-0.14	-0.08	-0.15	-0.11	-0.10	-0.10	-0.10	-0.10	-0.10	-0.09	-0.09	-0.09

	RANKED OUTPUT*				RANKED OUTPUT*				RANKED OUTPUT*							
	PK	TR	PK	TR	PK	TR	PK	TR	PK	TR	PK	TR	PK	TR		
VSTRNA	0.05	0.03	0.02	0.07	0.06	0.04	0.04	0.01	0.22	0.21	0.20	0.19	0.18	0.18	0.17	0.16
PITCH	-0.11	-0.12	-0.08	-0.09	-0.12	-0.15	-0.11	-0.13	-0.17	-0.16	-0.15	-0.14	-0.13	-0.12	-0.11	-0.11
VRWAC	0.13	0.31	0.11	0.52	0.21	0.15	0.28	0.14	0.28	0.26	0.26	0.26	0.26	0.26	0.26	0.26
VSTRNA	0.13	0.31	0.11	0.52	0.21	0.15	0.28	0.14	0.28	0.26	0.26	0.26	0.26	0.26	0.26	0.26
VEGAC	-0.06	-0.13	-0.11	-0.16	-0.14	-0.08	-0.15	-0.11	-0.10	-0.10	-0.10	-0.10	-0.10	-0.09	-0.09	-0.09

	MEAN VALUE	NO. OF PEAKS	RMS
WAVEHT	0.05	0	0.00
PITCH	-0.01	83	1.14
ROLL	-0.06	116	2.41
VRWAC	0.03	118	0.05
VSTRNA	0.03	30	0.05
VEGAC	-0.04	35	0.04
TRCGAC	-0.03	112	0.06
LMCGAC	-0.05	0	0.00

SEAWORTHINESS TEST RESULTS IN LOW SEA STATE 4 (26 FEB 1980)

226W10

RUN 10 FOLLOWING SEA, WPB, APPROX. 17 KNOTS

	CHRONOLOGICAL OUTPUT		AVERAGE		AVE 1/3		AVE 1/10		EXTREME							
	PK	TR	PK	TR	PK	TR	PK	TR	PK	TR						
FITCH	1.09	-0.24	1.53	1.29	0.54	0.15	0.88	1.95	1.19	-1.17	2.07	-1.96	2.75	-2.64	3.61	-3.53
ROLL	-0.78	-1.35	-1.25	-2.00	-0.73	-2.29	-1.29	-1.03	5.52	-5.11	9.93	-9.80	12.21	-14.08	14.79	-21.09
VCGAC	0.11	0.11	0.12	0.12	0.12	0.12	0.12	0.12	0.11	0.12	0.12	0.12	0.22	-0.24	0.28	-0.33
TRCGAC	0.13	0.13	0.13	0.13	0.13	0.13	0.13	0.13	0.13	0.14	0.23	-0.22	0.33	-0.26	0.45	-0.38
LMCGAC	0.06	0.06	0.07	0.07	0.07	0.07	0.07	0.07	0.06	-0.07	0.08	-0.09	0.08	-0.10	0.08	-0.10
CHRONOLOGICAL OUTPUT											1	16				
FITCH	3.08	10.74	14.79	7.81	4.98	-1.12	8.35	3.71	3.61	3.08	3.06	2.98	2.83	2.43	2.31	2.28
ROLL	-4.83	-9.03	-0.44	-0.93	-1.90	-4.35	-2.78	-2.25	-3.53	-3.24	-2.69	-2.62	-2.59	-2.39	-2.29	-2.23
VCGAC	0.13	0.13	0.13	0.13	0.13	0.13	0.13	0.13	0.13	0.13	0.13	0.13	0.13	0.13	0.13	0.13
TRCGAC	0.19	0.19	0.19	0.19	0.19	0.19	0.19	0.19	0.19	0.19	0.19	0.19	0.19	0.19	0.19	0.19
LMCGAC	0.05	0.05	0.05	0.05	0.05	0.05	0.05	0.05	0.05	0.05	0.05	0.05	0.05	0.05	0.05	0.05
CHRONOLOGICAL OUTPUT											2	16				
FITCH	2.18	2.18	2.18	2.18	2.18	2.18	2.18	2.18	2.18	2.18	2.13	2.12	2.10	2.08	2.07	2.02
ROLL	-2.29	-5.42	-3.91	-5.42	0.39	-6.74	-6.74	-0.20	-2.16	-2.10	-2.00	-2.00	-1.95	-1.92	-1.87	-1.82
VCGAC	0.13	0.13	0.13	0.13	0.13	0.13	0.13	0.13	0.13	0.13	0.13	0.13	0.13	0.13	0.13	0.13
TRCGAC	0.19	0.19	0.19	0.19	0.19	0.19	0.19	0.19	0.19	0.19	0.19	0.19	0.19	0.19	0.19	0.19
LMCGAC	0.05	0.05	0.05	0.05	0.05	0.05	0.05	0.05	0.05	0.05	0.05	0.05	0.05	0.05	0.05	0.05
CHRONOLOGICAL OUTPUT											3	16				
FITCH	14.79	13.82	13.62	12.99	11.96	11.91	11.72	11.04	14.79	13.82	13.62	12.99	11.96	11.91	11.72	11.04
ROLL	-21.09	-19.53	-16.80	-14.55	-12.84	-12.74	-11.62	-11.43	-21.09	-19.53	-16.80	-14.55	-12.84	-12.74	-11.62	-11.43
VCGAC	0.13	0.13	0.13	0.13	0.13	0.13	0.13	0.13	0.13	0.13	0.13	0.13	0.13	0.13	0.13	0.13
TRCGAC	0.19	0.19	0.19	0.19	0.19	0.19	0.19	0.19	0.19	0.19	0.19	0.19	0.19	0.19	0.19	0.19
LMCGAC	0.05	0.05	0.05	0.05	0.05	0.05	0.05	0.05	0.05	0.05	0.05	0.05	0.05	0.05	0.05	0.05
CHRONOLOGICAL OUTPUT											4	16				
FITCH	0.45	0.41	0.39	0.36	0.32	0.32	0.31	0.28	0.28	0.26	0.24	0.24	0.23	0.23	0.22	0.21
ROLL	-0.39	-0.28	-0.27	-0.27	-0.26	-0.25	-0.25	-0.25	-0.33	-0.32	-0.28	-0.28	-0.27	-0.25	-0.24	-0.24
VCGAC	0.20	0.20	0.20	0.20	0.20	0.20	0.20	0.20	0.20	0.20	0.20	0.20	0.20	0.20	0.20	0.19
TRCGAC	0.29	0.28	0.25	0.24	0.24	0.23	0.23	0.23	0.22	0.21	0.21	0.21	0.20	0.20	0.20	0.19
LMCGAC	0.04	0.04	0.04	0.04	0.04	0.04	0.04	0.04	0.04	0.04	0.04	0.04	0.04	0.04	0.04	0.04
CHRONOLOGICAL OUTPUT											5	9				
FITCH	0.01	0.01	0.01	0.01	0.01	0.01	0.01	0.01	0.01	0.01	0.01	0.01	0.01	0.01	0.01	0.01
ROLL	0.07	0.07	0.07	0.07	0.07	0.07	0.07	0.07	0.07	0.07	0.07	0.07	0.07	0.07	0.07	0.07
VCGAC	-0.00	-0.00	-0.00	-0.00	-0.00	-0.00	-0.00	-0.00	-0.00	-0.00	-0.00	-0.00	-0.00	-0.00	-0.00	-0.00
TRCGAC	-0.00	-0.00	-0.00	-0.00	-0.00	-0.00	-0.00	-0.00	-0.00	-0.00	-0.00	-0.00	-0.00	-0.00	-0.00	-0.00
LMCGAC	-0.00	-0.00	-0.00	-0.00	-0.00	-0.00	-0.00	-0.00	-0.00	-0.00	-0.00	-0.00	-0.00	-0.00	-0.00	-0.00
MEAN VALUE											NO. OF PEAKS		RMS			
FITCH											96	0.96				
ROLL											112	5.35				
VCGAC											166	0.08				
TRCGAC											121	0.12				
LMCGAC											9	0.02				

## SEAWORTHINESS TEST RESULTS IN SEA STATE 4 (13 MAR 1980)

313S01

## RUN 1 HEAD SEA, SES, APPROX. 10 KNOTS

CHRONOLOGICAL OUTPUT? 2 16		AVERAGE		AVE 1/3		AVE 1/10		EXTREME			
	PK	TR	PK	TR	PK	TR	PK	TR	PK	TR	
PITCH	4.31	2.78	1.87	1.01	5.32	5.31	6.62	4.95			
	-2.75	-3.78	-1.81	-1.55	-3.96	-5.76	-6.35	-6.61			
PITCH	3.78	1.33	0.24	1.64	2.47	3.34	3.50	3.48			
	-5.47	-3.63	-0.93	-0.83	-1.81	-4.75	-1.81	-3.89			
CHRONOLOGICAL OUTPUT? 3 16		RANKED OUTPUT? 2 16									
ROLL	5.62	4.00	3.96	0.44	2.98	0.15	2.93	2.88			
	-1.30	-2.88	-3.76	-0.88	-0.73	-2.39	-0.93	-2.05			
ROLL	2.54	3.61	1.66	2.15	3.61	1.66	2.15	6.20			
	-3.42	-2.49	-2.54	-1.51	-3.47	-1.86	-2.29	-3.22			
CHRONOLOGICAL OUTPUT? 4 16		RANKED OUTPUT? 3 16									
VIBWAC	0.39	-0.16	0.49	0.50	0.54	0.10	0.49	0.39			
	-0.16	-0.59	-0.55	0.20	0.07	-0.73	-0.21	0.20			
VIBWAC	0.33	0.16	0.55	-0.23	0.49	0.52	0.26	-0.23			
	-0.37	-0.08	-0.49	-0.49	-0.73	0.11	0.03	-0.44			
CHRONOLOGICAL OUTPUT? 5 16		RANKED OUTPUT? 4 16									
VSTRNA	0.28	0.16	0.83	0.10	-0.05	0.15	0.13	0.16			
	-0.27	0.05	0.02	-0.57	-0.32	-0.24	-0.07	0.03			
VSTRNA	0.62	0.16	0.08	0.02	0.39	0.14	0.26	0.07			
	0.01	0.05	-0.03	-0.16	-0.17	0.04	-0.12	-0.10			
CHRONOLOGICAL OUTPUT? 6 16		RANKED OUTPUT? 5 16									
VCGAC	0.22	0.32	0.15	0.06	0.22	0.08	0.11	0.51			
	-0.05	0.01	0.05	-0.05	-0.24	-0.42	-0.05	0.02			
VCGAC	0.26	0.21	0.22	0.22	0.12	0.25	0.09	0.24			
	-0.13	0.07	-0.11	0.00	-0.03	-0.14	-0.01	-0.35			
CHRONOLOGICAL OUTPUT? 7 16		RANKED OUTPUT? 6 16									
TRCGAC	0.11	0.06	0.10	0.04	0.04	0.09	0.06	0.02			
	-0.16	-0.12	-0.15	-0.08	-0.09	-0.13	-0.17	-0.09			
TRCGAC	0.02	0.08	0.09	0.07	0.09	0.09	0.10	0.03			
	-0.11	-0.11	-0.19	-0.13	-0.10	-0.12	-0.19	-0.17			
		MEAN VALUE		NO. OF PEAKS		RMS					
WAVENT	0.37										
PITCH	0.01										
ROLL	0.03										
VIBWAC	0.04										
VSTRNA	0.05										
VCGAC	0.05										
TRCGAC	-0.03										
LMCGAC	-0.04										

SEAWORTHINESS TEST RESULTS IN SEA STATE 4 (13 MAR 1980)

313W01

RUN 1 HEAD SEA, WPB, APPROX. 10 KNOTS

	AVERAGE		AVE 1/3		AVE 1/10		EXTREME
	PK	TR	PK	TR	PK	TR	
PITCH	2.78	-2.49	4.30	-4.14	5.39	-5.30	6.80
ROLL	5.02	-5.00	8.00	-8.01	10.13	-10.32	12.11
VBOWAC	0.41	-0.47	0.67	-0.73	0.90	-0.89	1.22
VSTRNA	0.26	-0.26	0.40	-0.42	0.49	-0.55	0.59
VCGAC	0.19	-0.23	0.28	-0.34	0.35	-0.44	0.42
TRCGAC	0.11	-0.15	0.18	-0.21	0.24	-0.26	0.29

PITCH	2.88	2.26	2.72	3.03	1.86	2.16	3.52	6.80
ROLL	-1.81	-2.99	1.03	-2.00	-0.60	-1.32	-2.13	-3.94
PITCH	4.46	6.25	2.26	3.37	1.04	2.05	2.18	5.11
ROLL	-2.85	-6.54	-2.91	-2.46	-0.80	-0.90	0.02	-2.52

RANKED OUTPUT? 2 16

PITCH	6.80	6.56	6.25	5.68	5.27	5.21	5.16	5.11
ROLL	-7.42	-6.75	-6.54	-5.34	-5.19	-5.19	-5.19	-4.90

PITCH	5.06	5.01	5.00	4.92	4.74	4.70	4.57	4.51
ROLL	-4.88	-4.64	-4.56	-4.31	-4.51	-4.46	-4.46	-4.41

RANKED OUTPUT? 3 16

ROLL	12.11	11.72	11.23	11.08	10.79	9.37	9.23	9.18
VBOWAC	-12.40	-11.43	-11.43	-11.13	-10.94	-10.21	-9.47	-9.37
ROLL	9.03	8.84	8.79	8.54	8.25	8.06	7.96	7.96
VBOWAC	-9.33	-8.96	-8.79	-8.64	-8.64	-8.35	-7.81	-7.76

ROLL	12.11	11.72	11.23	11.08	10.79	9.37	9.23	9.18
VBOWAC	-12.40	-11.43	-11.43	-11.13	-10.94	-10.21	-9.47	-9.37
ROLL	9.03	8.84	8.79	8.54	8.25	8.06	7.96	7.96
VBOWAC	-9.33	-8.96	-8.79	-8.64	-8.64	-8.35	-7.81	-7.76

RANKED OUTPUT? 4 16

VBOWAC	1.22	1.20	1.12	1.00	1.04	1.03	1.01	0.96
VSTRNA	-1.04	-1.03	-1.03	-0.98	-0.94	-0.93	-0.93	-0.93
VBOWAC	0.91	0.91	0.86	0.85	0.80	0.75	0.73	0.72
VSTRNA	-0.88	-0.88	-0.86	-0.85	-0.85	-0.83	-0.83	-0.83

VBOWAC	1.22	1.20	1.12	1.00	1.04	1.03	1.01	0.96
VSTRNA	-1.04	-1.03	-1.03	-0.98	-0.94	-0.93	-0.93	-0.93
VBOWAC	0.91	0.91	0.86	0.85	0.80	0.75	0.73	0.72
VSTRNA	-0.88	-0.88	-0.86	-0.85	-0.85	-0.83	-0.83	-0.83

RANKED OUTPUT? 5 16

VSTRNA	0.59	0.58	0.55	0.52	0.52	0.52	0.49	0.48
VSTRNA	-0.78	-0.65	-0.64	-0.61	-0.55	-0.54	-0.53	-0.53
VSTRNA	0.47	0.46	0.46	0.45	0.44	0.43	0.43	0.43
VSTRNA	-0.52	-0.51	-0.51	-0.51	-0.47	-0.46	-0.43	-0.42

VSTRNA	0.59	0.58	0.55	0.52	0.52	0.52	0.49	0.48
VSTRNA	-0.78	-0.65	-0.64	-0.61	-0.55	-0.54	-0.53	-0.53
VSTRNA	0.47	0.46	0.46	0.45	0.44	0.43	0.43	0.43
VSTRNA	-0.52	-0.51	-0.51	-0.51	-0.47	-0.46	-0.43	-0.42

RANKED OUTPUT? 6 16

VCGAC	0.42	0.42	0.40	0.38	0.37	0.35	0.34	0.33
VCGAC	-0.58	-0.55	-0.47	-0.47	-0.46	-0.46	-0.43	-0.42
VCGAC	0.33	0.33	0.33	0.33	0.31	0.31	0.30	0.29
VCGAC	-0.42	-0.41	-0.40	-0.39	-0.37	-0.37	-0.37	-0.37

VCGAC	0.42	0.42	0.40	0.38	0.37	0.35	0.34	0.33
VCGAC	-0.58	-0.55	-0.47	-0.47	-0.46	-0.46	-0.43	-0.42
VCGAC	0.33	0.33	0.33	0.33	0.31	0.31	0.30	0.29
VCGAC	-0.42	-0.41	-0.40	-0.39	-0.37	-0.37	-0.37	-0.37

RANKED OUTPUT? 7 16

TRCGAC	0.29	0.29	0.28	0.25	0.24	0.23	0.23	0.23
TRCGAC	-0.30	-0.28	-0.28	-0.28	-0.27	-0.26	-0.24	-0.24
TRCGAC	0.22	0.21	0.19	0.18	0.18	0.17	0.17	0.17
TRCGAC	-0.24	-0.23	-0.23	-0.22	-0.22	-0.22	-0.21	-0.21

MEAN VALUE	NO. OF PEAKS	RMS
0.00	0	0.00
0.20	140	2.10
-0.01	119	4.69
-0.01	201	0.34
0.03	151	0.19
-0.01	141	0.14
-0.02	117	0.09
-0.03	0	0.00

SEAWORTHINESS TEST RESULTS IN SEA STATE 4 (13 MAR 1980)

313S02

RUN 2 S.BEAM SEA, SES, APPROX. 10 KNOTS

	CHRONOLOGICAL OUTPUT? 2 16				AVERAGE				AVE 1/10				EXTREME	
	PK	TR	PK	TR	PK	TR	PK	TR	PK	TR	PK	TR	PK	TR
PITCH	1.81	3.53	1.46	3.99	0.42	0.36	1.87	1.37	3.78	-3.98	4.09	-4.33	4.09	-4.33
ROLL	-2.59	0.36	-3.32	0.00	-1.33	-4.33	-0.88	-0.37	7.46	-7.18	10.09	-9.29	14.60	-13.09
VRWAC									0.27	-0.26	0.33	-0.32	0.37	-0.46
USTRNA	2.10	1.90	1.77	3.43	1.84	1.11	0.88	1.14	0.23	-0.15	0.31	-0.20	0.42	-0.32
VCGAC	-0.34	-2.49	-2.34	-1.97	-3.82	-1.35	-1.76	-0.28	0.17	-0.10	0.20	-0.14	0.24	-0.20
TRCGAC									0.06	-0.12	0.09	-0.17	0.14	-0.23

	RANKED OUTPUT? 2 16							
PITCH	4.09	3.99	3.92	3.71	3.53	3.43	3.06	3.04
ROLL	-4.33	-4.20	-3.96	-3.86	-3.82	-3.71	-3.32	-3.24
VRWAC	2.86	2.86	2.65	2.64	2.60	2.57	2.49	2.36
USTRNA	-3.11	-2.95	-2.85	-2.83	-2.65	-2.60	-2.59	-2.49

	RANKED OUTPUT? 3 16							
ROLL	14.60	11.08	10.40	10.11	10.01	9.23	9.08	8.50
VRWAC	-13.09	-10.21	-9.72	-9.33	-9.13	-8.79	-8.69	-7.32
ROLL	7.81	7.81	7.52	7.47	7.47	7.32	7.23	7.13
VRWAC	-7.32	-7.08	-7.03	-7.03	-6.93	-6.93	-6.64	-6.49

	RANKED OUTPUT? 4 16							
VRWAC	0.37	0.37	0.36	0.36	0.34	0.34	0.33	0.31
VRWAC	-0.46	-0.42	-0.34	-0.31	-0.31	-0.31	-0.31	-0.29
USTRNA	0.31	0.31	0.31	0.29	0.29	0.28	0.28	0.28
USTRNA	-0.29	-0.29	-0.29	-0.29	-0.28	-0.28	-0.28	-0.28

	RANKED OUTPUT? 5 16							
USTRNA	0.42	0.40	0.39	0.37	0.35	0.33	0.33	0.31
USTRNA	-0.32	-0.28	-0.25	-0.24	-0.24	-0.23	-0.21	-0.21
USTRNA	0.30	0.30	0.30	0.29	0.29	0.29	0.28	0.28
USTRNA	-0.21	-0.20	-0.20	-0.20	-0.20	-0.20	-0.20	-0.19

	RANKED OUTPUT? 6 16							
VCGAC	0.24	0.22	0.21	0.20	0.20	0.20	0.20	0.20
VCGAC	-0.20	-0.16	-0.15	-0.15	-0.15	-0.14	-0.13	-0.13
VCGAC	0.19	0.19	0.18	0.18	0.18	0.18	0.18	0.18
VCGAC	-0.13	-0.13	-0.12	-0.12	-0.11	-0.11	-0.11	-0.11

	RANKED OUTPUT? 7 16							
TRCGAC	6.14	6.14	6.13	6.12	6.12	6.12	6.11	6.10
TRCGAC	-0.23	-0.22	-0.21	-0.19	-0.19	-0.19	-0.18	-0.18
TRCGAC	0.10	0.10	0.09	0.09	0.09	0.09	0.09	0.09
TRCGAC	-0.18	-0.16	-0.16	-0.16	-0.16	-0.16	-0.16	-0.16

	MEAN VALUE	NO. OF PEAKS	RMS
WAVEHT	0.39	0	0.00
PITCH	-0.02	66	1.44
ROLL	0.15	91	4.09
VRWAC	0.03	138	0.11
USTRNA	0.04	248	0.08
VCGAC	0.05	139	0.06
TRCGAC	-0.02	88	0.06
LWCGAC	-0.04	0	0.00

SEAWORTHINESS TEST RESULTS IN SEA STATE 4 (13 MAR 1980)

RUN 2S.BEAM SEA, WPB, APPROX. 10 KNOTS

313W02

CHRONOLOGICAL OUTPUT	2		16		2		16		2		16		2		16		2		16	
	AVE	TR	AVE	TR	AVE	TR	AVE	TR	AVE	TR	AVE	TR	AVE	TR	AVE	TR	AVE	TR	AVE	TR
PITCH	2.47	2.73	1.35	2.13	2.07	2.07	2.60	2.75	2.28	-0.31	3.29	-1.24	3.80	-1.91	4.18	-2.98	4.18	-2.98	4.18	-2.98
ROLL	-0.88	0.52	0.33	0.08	0.02	0.86	0.70	-0.18	5.39	-7.72	10.59	-12.85	14.01	-16.55	15.77	-18.90	15.77	-18.90	15.77	-18.90
PITCH	2.29	2.03	2.75	1.06	3.52	2.78	1.56	1.77	0.18	0.24	-0.33	0.38	0.49	0.49	0.42	-0.76	0.42	-0.76	0.42	-0.76
ROLL	0.54	0.33	0.31	-0.29	-0.76	1.07	0.36	-0.26	0.13	-0.17	0.18	-0.23	0.23	-0.27	0.28	-0.33	0.28	-0.33	0.28	-0.33
TRCGAC	0.12	-0.14	0.21	-0.24					0.12	-0.14	0.21	-0.24	0.30	-0.33	0.34	-0.37	0.34	-0.37	0.34	-0.37
KANKED OUTPUT? 2 16																				
PITCH	4.18	4.02	3.99	3.97	3.81	3.76	3.68		-2.98	-2.56	-1.99	-1.97	-1.97	-1.92	-1.73	-1.71				
ROLL	13.67	10.45	2.49	12.45	12.30	7.47	15.77	14.11	-14.01	-16.41	-18.80	-16.41	-16.41	-15.87	-14.75	-14.75				
PITCH	2.44	1.66	4.54	-0.24	2.98	7.13	5.91	6.69	-9.47	-6.84	0.63	-4.83	-3.17	-7.18	-10.21	-8.64				
ROLL	2.44	1.66	4.54	-0.24	2.98	7.13	5.91	6.69	-9.47	-6.84	0.63	-4.83	-3.17	-7.18	-10.21	-8.64				
KANKED OUTPUT? 3 16																				
ROLL	15.77	15.72	14.11	14.11	14.11	13.67	13.67	12.45	-18.90	-18.90	-18.80	-16.41	-16.41	-15.87	-14.75	-14.75				
PITCH	12.45	12.30	12.30	10.84	10.64	10.64	10.45	10.45	-14.21	-14.21	-14.06	-14.01	-14.01	-13.92	-13.23	-13.13				
KANKED OUTPUT? 4 16																				
VROMAC	0.65	0.65	0.60	0.60	0.59	0.54	0.47	0.46	-0.76	-0.75	-0.68	-0.68	-0.67	-0.65	-0.65	-0.62				
VSTRNA	0.44	0.44	0.44	0.44	0.44	0.42	0.41	0.41	-0.62	-0.62	-0.59	-0.57	-0.55	-0.55	-0.55	-0.55				
KANKED OUTPUT? 5 16																				
VSTRNA	0.42	0.36	0.34	0.32	0.31	0.31	0.30	0.28	-0.42	-0.33	-0.30	-0.30	-0.29	-0.29	-0.28	-0.28				
VCGAC	0.28	0.27	0.26	0.25	0.25	0.25	0.24	0.24	-0.28	-0.28	-0.28	-0.27	-0.27	-0.27	-0.27	-0.26				
KANKED OUTPUT? 6 16																				
VCGAC	0.28	0.26	0.25	0.24	0.24	0.24	0.24	0.24	-0.33	-0.28	-0.28	-0.27	-0.26	-0.26	-0.26	-0.26				
VCGAC	0.20	0.19	0.19	0.18	0.18	0.18	0.18	0.18	-0.25	-0.25	-0.24	-0.24	-0.24	-0.24	-0.24	-0.24				
KANKED OUTPUT? 7 16																				
TRCGAC	0.34	0.34	0.32	0.31	0.30	0.30	0.27	0.27	-0.37	-0.37	-0.35	-0.35	-0.33	-0.32	-0.32	-0.31				
TRCGAC	0.26	0.26	0.22	0.22	0.22	0.22	0.21	0.21	-0.31	-0.28	-0.27	-0.25	-0.24	-0.24	-0.23	-0.23				
KANKED OUTPUT? 7 16																				
TRCGAC	0.26	0.26	0.22	0.22	0.22	0.22	0.21	0.21	-0.31	-0.28	-0.27	-0.25	-0.24	-0.24	-0.23	-0.23				

MEAN VALUE	NO. OF PEAKS	RMS
WAVEHT	-1	0.00
PITCH	127	0.79
ROLL	93	5.38
VROMAC	178	0.21
VSTRNA	124	0.11
VCGAC	101	0.09
TRCGAC	104	0.10
LMCGAC	-1	0.00

SEAWORTHINESS TEST RESULTS IN SEA STATE 4 (13 MAR 1980)

RUN 3 FOLLOWING SEA, SES, APPROX. 10 KNOTS

313S03

CHRONOLOGICAL OUTPUT?		2 16		AVERAGE		AVE 1/3		AVE 1/10		EXTREME						
		PK	TR	PK	TR	PK	TR	PK	TR	PK	TR					
FITCH	1.79	5.00	4.67	-0.08	3.55	4.44	2.29	1.42	2.41	-2.46	3.74	-3.83	4.70	-4.59	5.00	-5.47
	-2.75	-2.64	-5.47	-1.56	-2.18	-4.15	-4.15	-1.37	1.92	-1.98	3.25	-3.45	4.61	-4.65	5.57	-7.08
FITCH	1.92	3.16	3.14	2.82	3.09	1.64	2.13	2.64	0.16	-0.08	0.20	-0.12	0.21	-0.16	0.21	-0.16
	-1.79	-1.50	-3.42	-2.86	-2.44	-2.21	-1.74	-2.64	0.12	-0.03	0.16	-0.06	0.21	-0.09	0.35	-0.12
									0.11	-0.00	0.12	-0.02	0.13	-0.03	0.13	-0.03
									0.04	-0.10	0.05	-0.12	0.07	-0.13	0.07	-0.16

CHRONOLOGICAL OUTPUT?		3 16		RANKED OUTPUT?		2 16		
FOLL	0.59	2.69	1.42	1.76	2.73	0.93	3.81	5.57
	-2.34	-0.73	-1.37	-2.25	-0.49	-2.00	-1.61	-7.08
ROLL	2.29	4.49	0.73	2.44	2.05	2.54	-0.44	2.00
	-3.47	-2.39	-3.03	-2.93	-0.54	-2.64	-1.71	-3.51

CHRONOLOGICAL OUTPUT?		4 16		RANKED OUTPUT?		3 16		
VRQWAC	0.18	0.13	0.15	0.15	0.18	0.11	0.13	0.13
	-0.05	-0.07	-0.07	-0.10	-0.08	-0.08	-0.16	-0.16
VRQWAC	0.20	0.16	0.21	0.20	0.15	0.11	0.11	0.11
	-0.13	-0.05	-0.07	-0.07	-0.07	-0.05	-0.05	-0.05

CHRONOLOGICAL OUTPUT?		5 16		RANKED OUTPUT?		4 16		
USTRNA	0.11	0.11	0.11	0.11	0.10	0.11	0.11	0.12
	-0.02	-0.03	-0.02	0.02	0.02	-0.02	-0.06	-0.06
USTRNA	0.11	0.18	0.20	0.13	0.11	0.11	0.10	0.07
	-0.06	-0.01	-0.07	-0.06	-0.03	-0.02	-0.04	-0.02

CHRONOLOGICAL OUTPUT?		6 16		RANKED OUTPUT?		5 16		
VCGAC	0.11	0.11	0.11	0.11	0.10	0.11	0.11	0.12
	0.02	0.00	-0.01	-0.01	0.00	0.00	0.00	0.01
VCGAC	0.10	0.10	0.10	0.10	0.10	0.10	0.11	0.13
	0.00	0.00	0.00	-0.03	-0.02	0.00	0.00	-0.02

CHRONOLOGICAL OUTPUT?		7 16		RANKED OUTPUT?		6 16		
TRCGAC	0.04	0.04	0.06	0.06	0.04	0.02	0.03	0.05
	-0.08	-0.08	-0.16	-0.09	-0.10	-0.12	-0.08	-0.13
TRCGAC	0.07	0.02	0.03	0.04	0.03	0.05	0.02	0.05
	-0.11	-0.11	-0.08	-0.06	-0.08	-0.07	-0.10	-0.09

MEAN VALUE	NO. OF PEAKS	RMS
WAVEHT	0	0.00
FITCH	31	1.89
ROLL	64	1.66
VRQWAC	12	0.03
USTRNA	80	0.03
VCGAC	28	0.02
TRCGAC	30	0.03
TRCGAC	0	0.00

SEAWORTHINESS TEST RESULTS IN SEA STATE 4 (13 MAR 1980)

313W03

RUN 3 FOLLOWING SEA, WPB, APPROX. 10 KNOTS

CHRONOLOGICAL OUTPUT?		AVERAGE TR		AVE 1/3		AVE 1/10		EXTREME TR	
PK	TR	PK	TR	PK	TR	PK	TR	PK	TR
CHRONOLOGICAL OUTPUT? 2 16									
PITCH	1.46	2.44	2.23	1.79	1.99	3.30	-3.77	3.61	-3.82
ROLL	-0.96	-1.66	-2.02	-2.03	-2.77	9.84	-9.19	11.62	-10.16
VEGMAC	0.13	-0.16	0.16	-0.13	-0.15	0.17	-0.15	0.18	-0.18
VSTRNA	0.07	-0.07	0.10	-0.08	-0.12	0.12	-0.11	0.15	-0.11
VEGAC	0.05	-0.08	0.07	-0.10	-0.12	0.09	-0.12	0.11	-0.12
TRCGAC	0.07	-0.14	0.12	-0.20	-0.23	0.14	-0.23	0.16	-0.25
RANKED OUTPUT? 2 16									
PITCH	3.61	3.21	3.09	2.67	2.59	2.44	2.25	2.23	2.54
ROLL	-3.82	-3.74	-3.73	-3.55	-2.82	-2.77	-2.64	-2.54	-2.54
PITCH	2.13	1.99	1.99	1.97	1.95	1.86	1.82	1.79	1.79
ROLL	-2.33	-2.28	-2.12	-2.03	-2.02	-1.95	-1.87	-1.84	-1.84
RANKED OUTPUT? 3 16									
ROLL	11.62	10.94	10.25	9.62	9.52	8.64	8.30	8.15	8.15
ROLL	-10.16	-9.57	-9.42	-9.37	-8.94	-8.59	-8.30	-7.91	-7.91
ROLL	6.11	6.01	7.81	7.71	7.67	7.37	7.13	6.93	6.93
ROLL	-7.81	-7.42	-7.32	-7.03	-6.98	-6.93	-6.64	-6.54	-6.54
RANKED OUTPUT? 4 16									
VEGMAC	0.18	0.18	0.18	0.16	0.16	0.16	0.16	0.16	0.16
VEGMAC	-0.18	-0.15	-0.15	-0.15	-0.15	-0.13	-0.13	-0.13	-0.13
VEGMAC	0.15	0.15	0.15	0.15	0.15	0.15	0.15	0.15	0.15
VEGMAC	-0.15	-0.11	-0.11	-0.11	-0.11	-0.11	-0.11	-0.11	-0.11
RANKED OUTPUT? 5 16									
VSTRNA	0.15	0.12	0.11	0.11	0.11	0.11	0.10	0.10	0.09
VSTRNA	-0.11	-0.11	-0.10	-0.10	-0.09	-0.08	-0.08	-0.08	-0.08
VSTRNA	0.09	0.08	0.08	0.08	0.08	0.08	0.07	0.07	0.07
VSTRNA	-0.07	-0.07	-0.07	-0.07	-0.07	-0.07	-0.07	-0.07	-0.07
RANKED OUTPUT? 6 16									
VEGAC	0.11	0.09	0.08	0.07	0.07	0.06	0.06	0.06	0.06
VEGAC	-0.12	-0.12	-0.11	-0.10	-0.10	-0.10	-0.10	-0.10	-0.09
VEGAC	0.06	0.05	0.05	0.05	0.05	0.05	0.05	0.05	0.05
VEGAC	-0.05	-0.08	-0.08	-0.08	-0.07	-0.07	-0.07	-0.07	-0.07
RANKED OUTPUT? 7 16									
TRCGAC	0.16	0.15	0.14	0.13	0.13	0.13	0.12	0.12	0.12
TRCGAC	-0.25	-0.24	-0.23	-0.22	-0.21	-0.21	-0.21	-0.21	-0.21
TRCGAC	0.12	0.12	0.12	0.11	0.11	0.11	0.10	0.10	0.10
TRCGAC	-0.19	-0.19	-0.19	-0.19	-0.18	-0.18	-0.18	-0.18	-0.17

CHRONOLOGICAL OUTPUT?		AVERAGE TR		AVE 1/3		AVE 1/10		EXTREME TR	
PK	TR	PK	TR	PK	TR	PK	TR	PK	TR
CHRONOLOGICAL OUTPUT? 2 16									
PITCH	1.46	2.44	2.23	1.79	1.99	3.30	-3.77	3.61	-3.82
ROLL	-0.96	-1.66	-2.02	-2.03	-2.77	9.84	-9.19	11.62	-10.16
VEGMAC	0.13	-0.16	0.16	-0.13	-0.15	0.17	-0.15	0.18	-0.18
VSTRNA	0.07	-0.07	0.10	-0.08	-0.12	0.12	-0.11	0.15	-0.11
VEGAC	0.05	-0.08	0.07	-0.10	-0.12	0.09	-0.12	0.11	-0.12
TRCGAC	0.07	-0.14	0.12	-0.20	-0.23	0.14	-0.23	0.16	-0.25
RANKED OUTPUT? 2 16									
PITCH	3.61	3.21	3.09	2.67	2.59	2.44	2.25	2.23	2.54
ROLL	-3.82	-3.74	-3.73	-3.55	-2.82	-2.77	-2.64	-2.54	-2.54
PITCH	2.13	1.99	1.99	1.97	1.95	1.86	1.82	1.79	1.79
ROLL	-2.33	-2.28	-2.12	-2.03	-2.02	-1.95	-1.87	-1.84	-1.84
RANKED OUTPUT? 3 16									
ROLL	11.62	10.94	10.25	9.62	9.52	8.64	8.30	8.15	8.15
ROLL	-10.16	-9.57	-9.42	-9.37	-8.94	-8.59	-8.30	-7.91	-7.91
ROLL	6.11	6.01	7.81	7.71	7.67	7.37	7.13	6.93	6.93
ROLL	-7.81	-7.42	-7.32	-7.03	-6.98	-6.93	-6.64	-6.54	-6.54
RANKED OUTPUT? 4 16									
VEGMAC	0.18	0.18	0.18	0.16	0.16	0.16	0.16	0.16	0.16
VEGMAC	-0.18	-0.15	-0.15	-0.15	-0.15	-0.13	-0.13	-0.13	-0.13
VEGMAC	0.15	0.15	0.15	0.15	0.15	0.15	0.15	0.15	0.15
VEGMAC	-0.15	-0.11	-0.11	-0.11	-0.11	-0.11	-0.11	-0.11	-0.11
RANKED OUTPUT? 5 16									
VSTRNA	0.15	0.12	0.11	0.11	0.11	0.11	0.10	0.10	0.09
VSTRNA	-0.11	-0.11	-0.10	-0.10	-0.09	-0.08	-0.08	-0.08	-0.08
VSTRNA	0.09	0.08	0.08	0.08	0.08	0.08	0.07	0.07	0.07
VSTRNA	-0.07	-0.07	-0.07	-0.07	-0.07	-0.07	-0.07	-0.07	-0.07
RANKED OUTPUT? 6 16									
VEGAC	0.11	0.09	0.08	0.07	0.07	0.06	0.06	0.06	0.06
VEGAC	-0.12	-0.12	-0.11	-0.10	-0.10	-0.10	-0.10	-0.10	-0.09
VEGAC	0.06	0.05	0.05	0.05	0.05	0.05	0.05	0.05	0.05
VEGAC	-0.05	-0.08	-0.08	-0.08	-0.07	-0.07	-0.07	-0.07	-0.07
RANKED OUTPUT? 7 16									
TRCGAC	0.16	0.15	0.14	0.13	0.13	0.13	0.12	0.12	0.12
TRCGAC	-0.25	-0.24	-0.23	-0.22	-0.21	-0.21	-0.21	-0.21	-0.21
TRCGAC	0.12	0.12	0.12	0.11	0.11	0.11	0.10	0.10	0.10
TRCGAC	-0.19	-0.19	-0.19	-0.19	-0.18	-0.18	-0.18	-0.18	-0.17

MEAN VALUE	NO. OF PEMS	RMS
WAVEHT	0	0.00
PITCH	33	1.31
ROLL	78	3.68
VEGMAC	41	0.06
VSTRNA	48	0.04
VEGAC	33	0.03
TRCGAC	59	0.07
LNCGAC	0	0.00

SEAWORTHINESS TEST RESULTS IN SEA STATE 4 (13 MAR 1980)

RUN 4 P. BOW SEA, SES, APPROX. 10 KNOTS

313S04

	CHRONOLOGICAL OUTPUT* 2 16				AVERAGE				AVE 1/10				EXTREME			
	PK	TR	PK	TR	PK	TR	PK	TR	PK	TR	PK	TR	PK	TR		
PITCH	3.21	2.18	1.20	2.05	4.69	6.43	7.45	4.72	3.34	-3.40	5.80	-5.80	8.12	-7.47	10.64	-8.92
	-2.41	-1.38	-1.81	-0.36	-2.52	-7.32	-8.45	-5.14	3.38	-3.38	5.63	-5.37	7.17	-6.57	7.81	-7.23
									0.31	-0.24	0.54	-0.45	0.83	-0.60	1.56	-0.75
FITCH	2.33	1.69	3.58	4.46	1.61	6.41	3.0~	4.09	0.20	-0.09	0.39	-0.25	0.52	-0.38	0.75	-0.74
	-5.00	0.21	-3.45	-5.55	-1.56	-4.33	-5.96	-4.~9	0.15	-0.08	0.24	-0.20	0.30	-0.29	0.40	-0.39
									0.06	-0.11	0.10	-0.14	0.13	-0.16	0.17	-0.17

	RANKED OUTPUT* 3 16				RANKED OUTPUT* 2 16											
ROLL	5.66	1.71	3.56	3.47	5.42	5.57	4.35	3.08	10.64	9.54	8.53	7.52	7.45	7.34	7.06	6.87
	-4.05	-2.93	-1.22	-3.27	-3.17	-5.08	-5.32	-1.90	-8.92	-8.45	-8.33	-7.32	-6.97	-6.95	-6.88	-5.96
ROLL	2.00	0.24	5.96	2.54	-0.68	2.64	7.08	2.98	6.43	6.41	5.81	5.81	5.66	5.52	5.24	5.24
	-2.29	-0.78	-3.03	-5.03	-1.71	-1.81	-5.96	-5.47	-5.89	-5.84	-5.81	-5.75	-5.71	-5.60	-5.60	-5.55

	RANKED OUTPUT* 4 16				RANKED OUTPUT* 3 16											
VRQWAC	0.20	0.16	0.20	0.20	0.24	0.23	0.50	0.13	7.81	7.62	7.47	7.47	7.08	7.03	6.64	6.20
	-0.49	-0.03	-0.15	-0.03	-0.16	-0.28	-0.47	-0.33	-7.23	-7.23	-6.54	-6.45	-6.35	-6.35	-6.30	-6.10
VRQWAC	0.16	0.15	0.70	0.31	0.28	0.72	0.46	0.36	6.10	5.96	5.96	5.86	5.66	5.57	5.52	5.42
	-0.52	-0.42	-0.10	-0.28	-0.26	-0.50	-0.37	-0.05	-5.96	-5.71	-5.57	-5.52	-5.47	-5.32	-5.32	-5.08

	RANKED OUTPUT* 5 16				RANKED OUTPUT* 4 16											
USTRNA	0.33	0.14	0.13	0.11	0.20	0.11	0.06	0.08	1.56	1.40	1.25	1.03	0.91	0.91	0.81	0.78
	-0.03	-0.11	0.01	0.00	0.01	-0.07	-0.12	-0.09	-0.75	-0.73	-0.72	-0.67	-0.67	-0.63	-0.62	-0.62
USTRNA	0.13	0.19	0.19	0.18	0.30	0.15	0.20	0.19	0.78	0.75	0.73	0.72	0.70	0.67	0.67	0.65
	-0.05	0.03	-0.02	-0.20	0.06	0.04	-0.02	0.05	-0.60	-0.60	-0.57	-0.55	-0.55	-0.55	-0.54	-0.52

	RANKED OUTPUT* 6 16				RANKED OUTPUT* 5 16											
UCGAC	0.02	0.13	0.15	0.11	0.11	0.15	0.17	0.13	0.75	0.70	0.61	0.60	0.56	0.55	0.55	0.55
	-0.08	-0.07	0.02	-0.02	0.01	0.00	-0.09	0.03	-0.74	-0.73	-0.55	-0.50	-0.47	-0.44	-0.43	-0.41
UCGAC	0.33	0.27	-0.04	-0.07	0.29	0.18	0.23	0.15	0.54	0.52	0.52	0.52	0.51	0.51	0.50	0.49
	-0.19	0.06	-0.33	-0.28	-0.21	-0.16	-0.19	-0.25	-0.40	-0.39	-0.37	-0.37	-0.36	-0.35	-0.32	-0.32

	RANKED OUTPUT* 7 16				RANKED OUTPUT* 6 16											
TRCGAC	0.05	0.10	0.06	0.08	0.04	0.02	0.11	0.06	0.40	0.40	0.38	0.34	0.33	0.32	0.32	0.29
	-0.10	-0.09	-0.11	-0.10	-0.13	-0.08	-0.08	-0.12	-0.39	-0.36	-0.34	-0.34	-0.33	-0.31	-0.30	-0.29
TRCGAC	0.09	0.09	0.06	0.11	0.07	0.14	0.07	0.04	0.29	0.28	0.28	0.27	0.27	0.27	0.26	0.25
	-0.14	-0.17	-0.09	-0.13	-0.09	-0.12	-0.17	-0.11	-0.29	-0.28	-0.28	-0.28	-0.28	-0.26	-0.25	-0.24

	MEAN VALUE	NO. OF PEAKS	RMS
WAVEHT	0.32	0	0.00
PITCH	0.00	86	2.81
ROLL	-0.02	89	2.74
VRQWAC	0.03	204	0.21
USTRNA	0.05	277	0.14
UCGAC	0.05	199	0.10
TRCGAC	-0.03	76	0.05
LNGCAC	-0.04	0	0.00

SEAWORTHINESS TEST RESULTS IN SEA STATE 4 (13 MAR 1980)

RUN 4 P.BOW SEA, WPB, APPROX. 10 KNOTS

313W04

	CHRONOLOGICAL OUTPUT? 2 16				AVERAGE 2 16				AVE 1/3				EXTREME TR			
	PK	TR	PK	TR	PK	TR	PK	TR	PK	TR	PK	TR	PK	TR	PK	TR
PITCH	3.87	2.83	5.21	3.27	1.90	0.28	4.09	5.78	2.48	-2.77	4.07	-4.50	5.11	-5.77	6.01	-7.41
ROLL	-5.14	-1.33	-4.95	-5.60	-2.08	-1.84	-1.01	-4.62	6.93	-6.91	11.58	-10.98	15.12	-14.54	20.95	-16.99
UPWAC	0.52	4.05	2.46	3.56	0.23	3.55	2.12	3.19	0.36	-0.36	0.59	-0.57	0.83	-0.78	1.16	-1.03
USTRNA	-4.00	-1.64	-3.45	-3.94	-1.45	-1.38	-4.62	-2.13	0.30	-0.21	0.32	-0.36	0.41	-0.48	0.47	-0.59
VCGAC	0.13	-0.19	0.23	-0.31	0.19	0.23	-0.42	0.42	0.13	-0.19	0.23	-0.31	0.31	-0.42	0.42	-0.59
TRCGAC	0.11	-0.19	0.19	-0.28	0.19	-0.28	0.25	0.41	0.11	-0.19	0.19	-0.28	0.25	-0.36	0.41	-0.44
	RANKED OUTPUT? 2 16															
PITCH	6.01	5.78	5.45	5.21	5.14	4.90	4.83	4.75	6.01	-7.24	-6.27	-5.60	-5.42	-5.37	-5.29	-5.14
ROLL	-7.41	-7.24	-6.27	-5.60	-5.42	-5.37	-5.29	-5.14	-7.41	4.57	4.43	4.38	4.35	4.33	4.09	4.04
UPWAC	4.57	4.43	4.38	4.35	4.33	4.09	4.04	4.04	4.57	-4.95	-4.62	-4.57	-4.54	-4.49	-4.46	-4.46
USTRNA	-5.01	-4.95	-4.62	-4.57	-4.54	-4.49	-4.46	-4.46	-5.01	20.95	20.36	13.92	13.43	13.09	12.99	12.70
VCGAC	20.95	20.36	13.92	13.43	13.09	12.99	12.70	12.70	20.95	-16.99	-16.94	-13.87	-13.57	-13.13	-12.99	-12.45
TRCGAC	-16.99	-16.94	-13.87	-13.57	-13.13	-12.99	-12.45	-12.45	-16.99	12.35	12.21	12.16	12.06	11.77	11.62	10.99
	RANKED OUTPUT? 3 16															
PITCH	12.35	12.21	12.16	12.06	11.77	11.62	10.99	10.50	12.35	12.40	11.38	10.89	10.74	10.40	10.40	10.01
ROLL	12.40	12.40	11.38	10.89	10.74	10.40	10.01	10.01	12.40	1.16	1.06	0.96	0.94	0.93	0.78	0.75
UPWAC	1.16	1.06	0.96	0.94	0.93	0.78	0.75	0.75	1.16	-0.94	-0.91	-0.83	-0.81	-0.76	-0.73	-0.73
USTRNA	-0.94	-0.91	-0.83	-0.81	-0.76	-0.73	-0.73	-0.73	-0.94	0.75	0.70	0.68	0.67	0.63	0.62	0.62
VCGAC	0.75	0.70	0.68	0.67	0.63	0.62	0.62	0.62	0.75	-0.70	-0.70	-0.70	-0.65	-0.60	-0.59	-0.59
TRCGAC	-0.70	-0.70	-0.70	-0.65	-0.60	-0.59	-0.59	-0.59	-0.70	0.47	0.45	0.44	0.44	0.43	0.42	0.42
	RANKED OUTPUT? 4 16															
PITCH	0.47	0.45	0.44	0.44	0.44	0.43	0.42	0.42	0.47	0.58	0.54	0.51	0.50	0.50	0.48	0.46
ROLL	0.58	0.54	0.51	0.50	0.50	0.48	0.46	0.46	0.58	0.39	0.37	0.37	0.36	0.35	0.35	0.33
UPWAC	0.39	0.37	0.37	0.36	0.35	0.35	0.33	0.33	0.39	-0.42	-0.42	-0.42	-0.41	-0.39	-0.37	-0.37
USTRNA	-0.42	-0.42	-0.42	-0.41	-0.39	-0.37	-0.37	-0.37	-0.42	0.42	0.45	0.44	0.44	0.43	0.42	0.42
VCGAC	0.42	0.45	0.44	0.44	0.44	0.43	0.42	0.42	0.42	-0.59	-0.58	-0.54	-0.50	-0.48	-0.46	-0.46
TRCGAC	-0.59	-0.58	-0.54	-0.50	-0.48	-0.46	-0.46	-0.46	-0.59	0.39	0.37	0.37	0.36	0.35	0.35	0.33
	RANKED OUTPUT? 5 16															
PITCH	0.39	0.37	0.37	0.36	0.35	0.35	0.33	0.33	0.39	0.42	0.45	0.44	0.44	0.43	0.42	0.42
ROLL	0.42	0.45	0.44	0.44	0.44	0.43	0.42	0.42	0.42	-0.59	-0.58	-0.54	-0.50	-0.48	-0.46	-0.46
UPWAC	0.42	0.45	0.44	0.44	0.44	0.43	0.42	0.42	0.42	0.39	0.37	0.37	0.36	0.35	0.35	0.33
USTRNA	0.39	0.37	0.37	0.36	0.35	0.35	0.33	0.33	0.39	-0.42	-0.42	-0.42	-0.41	-0.39	-0.37	-0.37
VCGAC	0.42	0.45	0.44	0.44	0.44	0.43	0.42	0.42	0.42	0.42	0.45	0.44	0.44	0.43	0.42	0.42
TRCGAC	-0.59	-0.58	-0.54	-0.50	-0.48	-0.46	-0.46	-0.46	-0.59	0.42	0.36	0.34	0.33	0.32	0.30	0.30
	RANKED OUTPUT? 6 16															
PITCH	0.42	0.36	0.34	0.33	0.32	0.32	0.30	0.30	0.42	0.50	0.47	0.46	0.44	0.40	0.37	0.37
ROLL	0.50	0.47	0.46	0.44	0.44	0.43	0.42	0.42	0.50	0.39	0.37	0.37	0.36	0.35	0.35	0.33
UPWAC	0.39	0.37	0.37	0.36	0.35	0.35	0.33	0.33	0.39	0.42	0.45	0.44	0.44	0.43	0.42	0.42
USTRNA	0.42	0.45	0.44	0.44	0.44	0.43	0.42	0.42	0.42	0.39	0.37	0.37	0.36	0.35	0.35	0.33
VCGAC	0.42	0.45	0.44	0.44	0.44	0.43	0.42	0.42	0.42	0.42	0.45	0.44	0.44	0.43	0.42	0.42
TRCGAC	-0.59	-0.50	-0.47	-0.46	-0.44	-0.40	-0.37	-0.37	-0.59	0.27	0.26	0.26	0.25	0.25	0.24	0.24
	RANKED OUTPUT? 7 16															
PITCH	0.27	0.26	0.26	0.25	0.25	0.25	0.24	0.24	0.27	0.35	0.34	0.33	0.33	0.31	0.30	0.29
ROLL	0.35	0.34	0.34	0.33	0.33	0.32	0.32	0.30	0.35	0.35	0.34	0.33	0.32	0.32	0.30	0.29
UPWAC	0.27	0.26	0.26	0.25	0.25	0.25	0.24	0.24	0.27	0.35	0.34	0.33	0.33	0.31	0.30	0.29
USTRNA	0.27	0.26	0.26	0.25	0.25	0.25	0.24	0.24	0.27	0.35	0.34	0.33	0.33	0.31	0.30	0.29
VCGAC	0.27	0.26	0.26	0.25	0.25	0.25	0.24	0.24	0.27	0.35	0.34	0.33	0.33	0.31	0.30	0.29
TRCGAC	-0.37	-0.35	-0.34	-0.33	-0.33	-0.31	-0.30	-0.29	-0.37	0.41	0.31	0.24	0.23	0.21	0.21	0.20
	RANKED OUTPUT? 8 16															
PITCH	0.41	0.31	0.24	0.23	0.21	0.21	0.21	0.20	0.41	0.42	0.40	0.38	0.38	0.32	0.31	0.29
ROLL	0.42	0.31	0.24	0.23	0.21	0.21	0.20	0.20	0.42	0.42	0.40	0.38	0.38	0.32	0.31	0.29
UPWAC	0.41	0.31	0.24	0.23	0.21	0.21	0.20	0.20	0.41	0.42	0.40	0.38	0.38	0.32	0.31	0.29
USTRNA	0.42	0.31	0.24	0.23	0.21	0.21	0.20	0.20	0.42	0.42	0.40	0.38	0.38	0.32	0.31	0.29
VCGAC	0.41	0.31	0.24	0.23	0.21	0.21	0.20	0.20	0.41	0.42	0.40	0.38	0.38	0.32	0.31	0.29
TRCGAC	-0.44	-0.42	-0.40	-0.38	-0.38	-0.32	-0.31	-0.29	-0.44	0.20	0.20	0.20	0.19	0.19	0.19	0.18
	RANKED OUTPUT? 9 16															
PITCH	0.20	0.20	0.20	0.20	0.19	0.19	0.19	0.18	0.20	0.28	0.27	0.27	0.27	0.26	0.26	0.26
ROLL	0.20	0.20	0.20	0.20	0.19	0.19	0.19	0.18	0.20	0.28	0.27	0.27	0.27	0.26	0.26	0.26
UPWAC	0.20	0.20	0.20	0.20	0.19	0.19	0.19	0.18	0.20	0.28	0.27	0.27	0.27	0.26	0.26	0.26
USTRNA	0.20	0.20	0.20	0.20	0.19	0.19	0.19	0.18	0.20	0.28	0.27	0.27	0.27	0.26	0.26	0.26
VCGAC	0.20	0.20	0.20	0.20	0.19	0.19	0.19	0.18	0.20	0.28	0.27	0.27	0.27	0.26	0.26	0.26
TRCGAC	-0.29	-0.28	-0.27	-0.27	-0.27	-0.27	-0.26	-0.26	-0.29	0.00	0.00	0.00	0.00	0.00	0.00	

SEAWORTHINESS TEST RESULTS IN SEA STATE 4 (13 MAR 1980)

313S05

CHRONOLOGICAL OUTPUT? 2 16

PITCH 3.58 4.22 3.65 -0.02 2.12 3.42 2.72 1.48  
 -2.93 -4.59 -3.45 -2.00 -1.45 -2.95 -3.79 -2.86

PITCH 3.50 3.08 2.25 2.67 4.39 3.37 2.23 3.32  
 0.08 -3.42 -3.55 -3.12 -3.42 -2.80 -3.21 -2.60

CHRONOLOGICAL OUTPUT? 3 16

ROLL 1.76 1.03 2.05 0.39 3.17 2.93 1.61 7.47  
 -3.91 -0.83 -0.54 -1.66 -1.12 -1.61 -4.54 -2.64

ROLL 3.71 4.93 -0.78 1.90 4.20 7.91 1.07 5.81  
 -2.39 -2.29 -2.88 -3.52 -3.96 -6.25 -3.66

CHRONOLOGICAL OUTPUT? 4 16

VBOWAC 0.15 0.16 0.23 0.16 0.15 0.18 0.10 0.20  
 -0.10 -0.05 -0.11 -0.13 -0.05 -0.08 -0.10 -0.11

VBOWAC 0.16 0.16 0.15 0.15 0.15 0.15 0.13 0.16  
 -0.05 -0.13 -0.07 -0.10 -0.07 -0.08 -0.07 -0.07

CHRONOLOGICAL OUTPUT? 5 16

VSTRNA 0.09 0.08 0.07 0.11 0.15 0.14 0.14 0.11  
 -0.01 -0.02 -0.03 -0.05 -0.02 -0.02 0.02 0.01

VSTRNA 0.07 0.07 0.13 0.11 0.10 0.09 0.07 0.09  
 -0.06 -0.03 -0.05 0.00 0.00 -0.02 -0.03 -0.03

CHRONOLOGICAL OUTPUT? 6 16

VECGAC 0.09 0.13 0.09 0.15 0.12 0.12 0.10 0.11  
 -0.04 -0.01 -0.03 -0.07 -0.05 -0.02 0.00 0.00

VECGAC 0.15 0.13 0.11 0.12 0.14 0.10 0.09 0.11  
 -0.05 -0.01 -0.07 -0.01 -0.04 0.00 -0.02 -0.01

CHRONOLOGICAL OUTPUT? 7 16

TRCGAC 0.03 0.04 0.04 0.09 0.06 0.03 0.04 0.05  
 -0.09 -0.08 -0.07 -0.10 -0.11 -0.07 -0.07 -0.11

TRCGAC 0.06 0.16 0.03 0.10 0.06 0.06 0.05 0.07  
 -0.12 -0.09 -0.14 -0.08 -0.08 -0.07 -0.09 -0.08

WAVEHT	MEAN VALUE	NO. OF PEAKS	RMS
PITCH	0.32	0	0.00
ROLL	0.00	36	1.97
VBOWAC	0.03	88	2.74
VSTRNA	0.05	47	0.06
VECGAC	0.05	95	0.04
TRCGAC	-0.03	59	0.04
LINCEAC	-0.04	69	0.05
		0	0.00

AVERAGE TR AVE 1/3 TR AVE 1/10 TR EXTREME  
 PK TR PK TR PK TR PK TR  
 PITCH 2.62 -2.63 3.94 -3.76 4.72 -4.78 4.75 -5.84  
 VROMAC 3.08 -2.84 5.51 -4.95 7.17 -6.34 7.91 -7.71  
 VSTRNA 0.16 -0.09 0.20 -0.13 0.22 -0.17 0.23 -0.23  
 VECGAC 0.11 -0.03 0.15 -0.07 0.17 -0.10 0.18 -0.15  
 TRCGAC 0.12 -0.03 0.14 -0.05 0.15 -0.07 0.16 -0.07  
 0.06 -0.10 0.09 -0.12 0.12 -0.14 0.16 -0.16

RANKED OUTPUT? 2 16

PITCH 4.75 4.72 4.69 4.39 4.22 3.65 3.58 3.52  
 -5.84 -4.59 -3.91 -3.79 -3.55 -3.50 -3.45 -3.42

PITCH 3.50 3.50 3.42 3.40 3.37 3.32 3.22 3.08  
 -3.42 -3.32 -3.21 -3.14 -3.12 -2.95 -2.95 -2.93

RANKED OUTPUT? 3 16

ROLL 7.91 7.86 7.71 7.47 6.98 6.88 6.35 6.20  
 -7.71 -6.98 -6.79 -6.25 -5.81 -5.81 -5.76 -5.62

ROLL 6.15 5.86 5.81 5.71 5.42 5.37 5.32 5.08  
 -5.62 -5.27 -5.22 -5.08 -4.93 -4.88 -4.79 -4.59

RANKED OUTPUT? 4 16

VBOWAC 0.23 0.23 0.21 0.21 0.21 0.20 0.20 0.20  
 -0.23 -0.16 -0.15 -0.15 -0.13 -0.13 -0.13 -0.13

VBOWAC 0.20 0.20 0.20 0.18 0.18 0.18 0.18 0.16  
 -0.11 -0.11 -0.11 -0.11 -0.11 -0.11 -0.11 -0.10

RANKED OUTPUT? 5 16

VSTRNA 0.18 0.18 0.17 0.17 0.16 0.16 0.16 0.15  
 -0.15 -0.13 -0.13 -0.12 -0.09 -0.08 -0.08 -0.08

VSTRNA 0.15 0.15 0.15 0.15 0.15 0.15 0.15 0.15  
 -0.08 -0.07 -0.07 -0.07 -0.07 -0.07 -0.07 -0.07

RANKED OUTPUT? 6 16

VECGAC 0.16 0.15 0.15 0.15 0.15 0.15 0.15 0.14  
 -0.07 -0.07 -0.07 -0.07 -0.07 -0.06 -0.06 -0.05

VECGAC 0.14 0.14 0.14 0.14 0.14 0.14 0.14 0.13  
 -0.05 -0.05 -0.05 -0.05 -0.05 -0.04 -0.04 -0.04

RANKED OUTPUT? 7 16

TRCGAC 0.16 0.12 0.11 0.11 0.10 0.10 0.10 0.10  
 -0.16 -0.15 -0.14 -0.14 -0.14 -0.14 -0.13 -0.13

TRCGAC 0.09 0.09 0.09 0.09 0.09 0.09 0.09 0.08  
 -0.12 -0.12 -0.12 -0.12 -0.12 -0.12 -0.11 -0.11

SEAWORTHINESS TEST RESULTS IN SEA STATE 4 (13 MAR 1980)

RUN 5 P. QUARTERING SEA, WPB, APPROX. 10 KNOTS

313W05

CHRONOLOGICAL OUTPUT	2 16		AVERAGE		AVE 1/3		AVE 1/10		EXTREME							
	PK	TR	PK	TR	PK	TR	PK	TR	PK	TR						
FITCH	1.27	2.07	1.82	2.20	-0.07	1.94	2.28	1.72	-1.03	2.49	-1.82	3.05	-2.11	3.43	-2.62	
ROLL	-0.90	-0.13	-2.62	0.49	-1.73	-1.51	-1.87	0.75	4.76	-6.07	1.10	9.91	11.94	13.67	-16.60	
VROMAC	0.20	1.86	1.50	1.56	1.92	2.13	2.41	1.86	0.20	-0.1	27	0.33	-0.31	0.49	-0.39	
VSTRNA	0.10	0.10	0.0	0.0	0.0	0.0	0.0	0.19	0.10	-0.0	15	-0.14	0.17	0.23	-0.20	
VCGAC	-1.90	-0.88	-0.24	-1.16	-1.56	-0.88	-0.98	-2.03	0.08	-0.11	1.12	-0.15	0.16	-0.20	0.24	-0.23
TRCGAC	0.09	0.09	-0.16	-0.16	-0.22	-0.22	-0.27	0.21	0.09	-0.16	0.16	-0.22	0.21	-0.27	0.25	-0.30
RANKED OUTPUT? 2 16																
PITCH	2.78	1.56	6.20	1.45	8.40	2.83	0.78	1.03	3.47	3.26	2.88	2.85	2.82	2.72	2.41	2.36
ROLL	1.07	0.59	-1.42	-6.64	-11.13	-8.98	-5.57	-1.07	-2.62	-1.03	-2.00	-1.99	-1.90	-1.87	-1.79	-1.77
VROMAC	12.84	6.30	-1.05	5.47	9.52	-0.34	8.89	3.76	2.28	2.28	2.26	2.20	2.16	2.13	2.12	2.10
VSTRNA	-6.64	-9.03	-3.27	-2.39	-7.91	-9.37	-4.30	-9.57	-1.77	-1.73	-1.73	-1.71	-1.68	-1.61	-1.56	-1.56
RANKED OUTPUT? 3 16																
ROLL	13.67	12.99	12.84	11.67	11.57	10.55	10.30	9.62	13.67	12.99	12.84	11.67	11.57	10.55	10.30	9.62
VROMAC	-16.60	-12.74	-12.01	-11.43	-11.13	-10.74	-10.30	-10.30	-10.21	-10.16	-9.91	-9.67	-9.57	-9.37	-9.26	-9.03
VSTRNA	9.52	9.23	8.89	8.84	8.79	8.50	8.40	8.25	9.52	9.23	8.89	8.84	8.79	8.50	8.40	8.25
TRCGAC	-10.21	-10.16	-9.91	-9.67	-9.57	-9.37	-9.26	-9.03	-10.21	-10.16	-9.91	-9.67	-9.57	-9.37	-9.26	-9.03
RANKED OUTPUT? 4 16																
VROMAC	0.49	0.41	0.36	0.36	0.33	0.29	0.29	0.29	0.39	0.34	0.34	0.34	0.31	0.31	0.29	0.29
VSTRNA	-0.19	-0.19	-0.18	-0.18	-0.16	-0.16	-0.16	-0.16	-0.19	-0.19	-0.18	-0.18	-0.16	-0.16	-0.16	-0.16
VCGAC	0.28	0.28	0.28	0.28	0.28	0.28	0.28	0.28	0.28	0.28	0.28	0.28	0.28	0.28	0.28	0.28
TRCGAC	-0.28	-0.28	-0.26	-0.24	-0.24	-0.24	-0.24	-0.23	-0.28	-0.28	-0.26	-0.24	-0.24	-0.24	-0.23	-0.23
RANKED OUTPUT? 5 16																
VROMAC	0.09	0.11	0.07	0.09	0.01	0.23	0.06	0.08	0.09	0.04	0.06	0.06	0.06	0.06	0.06	0.08
VSTRNA	-0.10	-0.04	-0.10	-0.06	-0.10	-0.07	-0.08	-0.08	-0.10	-0.10	-0.10	-0.07	-0.07	-0.07	-0.07	-0.08
VCGAC	0.08	0.15	0.15	0.07	0.10	0.11	0.10	0.16	0.08	0.15	0.15	0.15	0.10	0.10	0.10	0.16
TRCGAC	-0.04	-0.07	-0.18	-0.15	-0.13	-0.05	-0.11	-0.11	-0.04	-0.07	-0.18	-0.15	-0.13	-0.11	-0.11	-0.11
RANKED OUTPUT? 6 16																
VCGAC	0.07	0.07	0.10	0.08	0.14	0.04	0.12	0.12	0.07	0.07	0.08	0.08	0.08	0.08	0.08	0.08
TRCGAC	-0.11	-0.07	-0.08	-0.15	-0.11	-0.07	-0.12	-0.11	-0.11	-0.07	-0.08	-0.15	-0.11	-0.07	-0.12	-0.11
VROMAC	0.02	0.05	0.05	0.12	0.05	0.20	0.07	0.08	0.02	0.05	0.12	0.05	0.20	0.07	0.08	0.08
VSTRNA	-0.10	-0.14	-0.11	-0.11	-0.10	-0.20	-0.11	-0.13	-0.10	-0.11	-0.10	-0.20	-0.11	-0.13	-0.13	-0.13
RANKED OUTPUT? 7 16																
VCGAC	0.13	0.21	0.12	0.09	0.02	0.13	0.09	0.02	0.13	0.21	0.12	0.09	0.02	0.13	0.09	0.02
TRCGAC	-0.15	-0.16	-0.20	-0.13	-0.09	-0.12	-0.28	-0.19	-0.15	-0.16	-0.20	-0.13	-0.09	-0.12	-0.28	-0.19
VROMAC	0.03	0.14	0.13	0.11	0.08	0.13	0.04	0.09	0.03	0.14	0.13	0.11	0.08	0.13	0.04	0.09
VSTRNA	-0.09	-0.15	-0.22	-0.09	-0.21	-0.09	-0.20	-0.11	-0.09	-0.15	-0.22	-0.09	-0.20	-0.11	-0.11	-0.11
MEAN VALUE NO. OF PEAKS RMS																
WAVENT	0.00	0	0.00	0	0.00	0	0.00	0.00	0.00	0	0.00	0	0.00	0	0.00	0.00
PITCH	0.39	52	1.11	77	4.91	110	0.07	75	0.09	75	0.09	75	0.09	75	0.09	75
ROLL	-0.59	77	4.91	110	0.07	75	0.07	75	0.09	75	0.09	75	0.09	75	0.09	75
VROMAC	0.02	107	0.07	75	0.06	75	0.06	75	0.09	75	0.09	75	0.09	75	0.09	75
VSTRNA	0.01	107	0.07	75	0.06	75	0.06	75	0.09	75	0.09	75	0.09	75	0.09	75
VCGAC	-0.02	95	0.06	75	0.06	75	0.06	75	0.09	75	0.09	75	0.09	75	0.09	75
TRCGAC	-0.04	75	0.06	75	0.06	75	0.06	75	0.09	75	0.09	75	0.09	75	0.09	75
LACGAC	-0.03	0	0.00	0	0.00	0	0.00	0.00	0.00	0	0.00	0	0.00	0	0.00	0.00

SEAWORTHINESS TEST RESULTS IN SEA STATE 4 (13 MAR 1980)

313506

RUN 6 HEAD SEA, SES, APPROX. 17 KNOTS

CHRONOLOGICAL OUTPUT		2 16		AVERAGE		AVE 1/3		AVE 1/10		EXTREME	
		PK	TR	PK	TR	PK	TR	PK	TR	PK	TR
PITCH	4.51	3.16	2.10	3.21	2.52	4.17	4.13	1.92	1.92	9.16	-8.45
	-5.94	-5.63	-3.04	-3.12	-3.01	-3.71	-2.96	-2.33	-2.33	5.91	-6.98
PITCH	5.47	2.13	3.12	9.16	5.29	5.86	4.17	3.11	3.11	1.09	-1.61
	-4.38	-4.51	-0.96	-6.90	-8.45	-6.53	-4.62	-3.45	-3.45	1.23	-0.64
										0.59	-0.59
										0.14	-0.19
CHRONOLOGICAL OUTPUT		3 16		RANKED OUTPUT		2 16					
ROLL	2.15	2.73	3.22	1.66	3.66	2.78	3.32	1.51	1.51	5.86	5.84
	-4.39	-0.73	-3.08	-2.63	-0.73	-3.71	-2.05	-2.78	-2.78	-6.18	-5.94
ROLL	5.08	2.93	1.41	1.61	2.98	1.37	2.98	1.17	1.17	5.26	5.05
	-2.93	-4.88	-2.65	-1.51	-3.03	-2.15	-2.93	-1.71	-1.71	-5.22	-5.11
CHRONOLOGICAL OUTPUT		4 16		RANKED OUTPUT		5 16					
VPOWAC	0.18	0.08	0.49	0.39	0.33	0.57	0.55	0.46	0.46	4.79	4.64
	-0.13	-0.13	-0.28	0.15	-0.02	-0.28	0.34	-0.46	-0.46	-5.37	-5.13
VPOWAC	0.39	0.20	0.42	0.39	0.10	0.31	0.46	0.46	0.46	4.30	4.15
	-0.78	-0.24	-0.28	0.13	-0.13	-0.23	-0.44	-0.47	-0.47	-4.54	-4.39
CHRONOLOGICAL OUTPUT		5 16		RANKED OUTPUT		6 16					
VSTRNA	0.20	0.11	0.07	0.26	0.28	0.30	0.37	-0.06	-0.06	0.96	0.90
	0.01	-0.12	-0.04	-0.21	-0.07	0.08	0.16	-0.15	-0.15	-1.24	-1.14
VSTRNA	-0.02	0.13	0.02	0.67	0.33	0.14	0.11	0.76	0.76	0.68	0.67
	-0.22	-0.30	-0.11	-0.09	0.10	0.03	-0.02	-0.21	-0.21	-0.98	-0.96
CHRONOLOGICAL OUTPUT		6 16		RANKED OUTPUT		7 16					
VCGAC	0.24	0.00	0.03	0.27	0.29	0.20	0.19	0.21	0.21	0.91	0.90
	0.05	-0.15	-0.16	-0.08	-0.03	-0.19	0.05	0.09	0.09	-0.51	-0.46
VCGAC	0.12	0.16	0.16	0.11	-0.02	0.21	0.14	0.07	0.07	0.77	0.76
	-0.02	-0.07	0.02	0.02	-0.14	-0.15	-0.10	-0.04	-0.04	-0.35	-0.33
CHRONOLOGICAL OUTPUT		7 16		RANKED OUTPUT		8 16					
TRCGAC	0.08	0.04	0.07	0.07	0.06	0.03	0.05	0.04	0.04	0.49	0.42
	-0.12	-0.10	-0.10	-0.15	-0.06	-0.14	-0.08	-0.13	-0.13	-0.42	-0.42
TRCGAC	0.11	0.08	0.04	0.04	0.04	0.09	0.03	0.02	0.02	0.36	0.35
	-0.10	-0.17	-0.08	-0.10	-0.12	-0.13	-0.10	-0.08	-0.08	-0.31	-0.29
MEAN VALUE		NO. OF PEAKS		RMS							
WAVEHT	0.29	0	0	0.00	0.00	0.00	0.00	0.00	0.00	0.12	0.11
PITCH	-0.01	94	94	2.76	2.76	2.26	2.26	2.26	2.26	0.12	0.12
ROLL	-0.08	73	73	2.26	2.26	0.18	0.18	0.18	0.18	0.10	0.10
VPOWAC	0.03	212	212	0.28	0.28	0.12	0.12	0.12	0.12	0.15	0.15
VSTRNA	0.04	366	366	0.18	0.18	0.06	0.06	0.06	0.06	0.10	0.10
VCGAC	0.05	399	399	0.12	0.12	0.06	0.06	0.06	0.06	0.15	0.15
TRCGAC	-0.02	98	98	0.06	0.06	0.06	0.06	0.06	0.06	0.15	0.15
LNCGAC	-0.04	0	0	0.00	0.00	0.00	0.00	0.00	0.00	0.15	0.15

SEAWORTHINESS TEST RESULTS IN SEA STATE 4 (13 MAR 1980)

313W06

RUN 6 HEAD SEA, WPB, APPROX. 17 KNOTS

	AVERAGE		AVE 1/3		AVE 1/10		EXTREME	
	PK	TR	PK	TR	PK	TR	PK	TR
PITCH	2.51	-2.99	4.27	-4.59	5.39	-5.86	6.22	-7.41
ROLL	4.29	-4.38	7.00	-7.46	9.02	-9.79	11.43	-11.99
VBOWAC	0.57	-0.50	0.94	-0.85	1.23	-1.02	1.60	-1.22
VSTRNA	0.29	-0.27	0.47	-0.48	0.60	-0.64	0.73	-0.89
VCGAC	0.23	-0.28	0.38	-0.47	0.49	-0.59	0.60	-0.89
TRCGAC	0.11	-0.14	0.17	-0.21	0.23	-0.25	0.33	-0.29

	CHRONOLOGICAL OUTPUT?		NO. OF PEAKS		RMS			
	MEAN VALUE	NO. OF PEAKS	MEAN VALUE	NO. OF PEAKS	MEAN VALUE	NO. OF PEAKS		
PITCH	1.71	1.09	4.15	5.14	3.06	4.59	0.15	4.52
ROLL	-0.78	-0.24	-1.30	-3.74	-5.18	-4.17	-2.28	-1.30
VSTRNA	5.70	6.10	1.55	0.23	4.23	5.05	4.30	5.63
VCGAC	-2.85	-5.14	-2.70	-1.55	-1.76	-2.75	-5.01	-3.76

	RANKED OUTPUT?		NO. OF PEAKS		RMS			
	MEAN VALUE	NO. OF PEAKS	MEAN VALUE	NO. OF PEAKS	MEAN VALUE	NO. OF PEAKS		
PITCH	6.22	6.10	5.70	5.63	5.44	5.16	5.14	5.05
ROLL	-7.41	-6.32	-6.15	-6.07	-6.02	-5.45	-5.44	-5.40
VSTRNA	4.75	4.72	4.59	4.52	4.30	4.28	4.23	4.15
VCGAC	-5.18	-5.14	-5.01	-4.64	-4.62	-4.61	-4.61	-4.56

	RANKED OUTPUT?		NO. OF PEAKS		RMS			
	MEAN VALUE	NO. OF PEAKS	MEAN VALUE	NO. OF PEAKS	MEAN VALUE	NO. OF PEAKS		
PITCH	11.43	11.38	9.37	8.74	8.15	8.11	7.81	7.18
ROLL	-10.99	-10.89	-10.45	-9.96	-9.57	-9.13	-8.69	-8.64
VSTRNA	7.13	6.88	6.74	6.69	6.64	6.59	6.59	6.49
VCGAC	-8.20	-7.86	-7.57	-7.47	-7.42	-7.37	-7.32	-7.28

	RANKED OUTPUT?		NO. OF PEAKS		RMS			
	MEAN VALUE	NO. OF PEAKS	MEAN VALUE	NO. OF PEAKS	MEAN VALUE	NO. OF PEAKS		
PITCH	1.60	1.48	1.43	1.29	1.27	1.24	1.22	1.19
ROLL	-1.22	-1.11	-1.09	-1.07	-1.04	-1.01	-0.99	-0.99
VSTRNA	1.19	1.16	1.09	1.03	1.03	0.96	0.94	0.93
VCGAC	-0.98	-0.96	-0.96	-0.94	-0.94	-0.94	-0.94	-0.93

	RANKED OUTPUT?		NO. OF PEAKS		RMS			
	MEAN VALUE	NO. OF PEAKS	MEAN VALUE	NO. OF PEAKS	MEAN VALUE	NO. OF PEAKS		
PITCH	0.73	0.71	0.68	0.65	0.63	0.62	0.59	0.57
ROLL	-1.12	-0.94	-0.71	-0.64	-0.63	-0.63	-0.57	-0.57
VSTRNA	0.56	0.55	0.52	0.52	0.50	0.50	0.50	0.50
VCGAC	-0.57	-0.55	-0.52	-0.52	-0.51	-0.51	-0.50	-0.50

	RANKED OUTPUT?		NO. OF PEAKS		RMS			
	MEAN VALUE	NO. OF PEAKS	MEAN VALUE	NO. OF PEAKS	MEAN VALUE	NO. OF PEAKS		
PITCH	0.60	0.56	0.56	0.55	0.50	0.48	0.46	0.45
ROLL	-0.89	-0.65	-0.59	-0.59	-0.58	-0.57	-0.56	-0.55
VSTRNA	0.44	0.44	0.43	0.43	0.42	0.42	0.41	0.40
VCGAC	-0.54	-0.54	-0.54	-0.53	-0.53	-0.52	-0.52	-0.50

	RANKED OUTPUT?		NO. OF PEAKS		RMS			
	MEAN VALUE	NO. OF PEAKS	MEAN VALUE	NO. OF PEAKS	MEAN VALUE	NO. OF PEAKS		
PITCH	0.33	0.24	0.23	0.23	0.22	0.21	0.20	0.20
ROLL	-0.29	-0.28	-0.27	-0.27	-0.23	-0.23	-0.23	-0.23
VSTRNA	0.19	0.19	0.18	0.18	0.17	0.17	0.16	0.15
VCGAC	-0.22	-0.22	-0.22	-0.22	-0.21	-0.21	-0.21	-0.21

	RANKED OUTPUT?		NO. OF PEAKS		RMS			
	MEAN VALUE	NO. OF PEAKS	MEAN VALUE	NO. OF PEAKS	MEAN VALUE	NO. OF PEAKS		
PITCH	0.00	0	0.00	0	0.00	0	0.00	0
ROLL	-0.17	102	0.00	102	2.22	2.22	3.60	3.60
VSTRNA	0.02	85	0.02	85	0.42	0.42	0.24	0.24
VCGAC	0.03	149	0.03	149	0.21	0.21	0.09	0.09
TRCGAC	-0.01	87	-0.01	87	0.09	0.09	0.00	0.00

	RANKED OUTPUT?		NO. OF PEAKS		RMS			
	MEAN VALUE	NO. OF PEAKS	MEAN VALUE	NO. OF PEAKS	MEAN VALUE	NO. OF PEAKS		
PITCH	0.09	0.13	0.26	0.26	0.30	0.56	0.20	0.60
ROLL	-0.10	-0.07	-0.19	-0.53	0.00	-0.89	-0.19	-0.54
VSTRNA	0.22	0.45	0.09	0.37	0.46	0.12	0.15	0.35
VCGAC	-0.30	-0.24	-0.39	-0.14	-0.46	-0.29	-0.20	-0.23

	RANKED OUTPUT?		NO. OF PEAKS		RMS			
	MEAN VALUE	NO. OF PEAKS	MEAN VALUE	NO. OF PEAKS	MEAN VALUE	NO. OF PEAKS		
PITCH	0.12	0.06	0.10	0.20	0.15	0.09	0.09	0.10
ROLL	-0.09	-0.11	-0.09	-0.08	-0.01	-0.05	-0.11	-0.02
VSTRNA	0.08	0.12	0.05	0.15	0.15	0.10	0.08	0.12
VCGAC	-0.10	-0.10	-0.23	-0.12	-0.13	-0.11	-0.12	-0.11

	RANKED OUTPUT?		NO. OF PEAKS		RMS			
	MEAN VALUE	NO. OF PEAKS	MEAN VALUE	NO. OF PEAKS	MEAN VALUE	NO. OF PEAKS		
PITCH	0.00	0	0.00	0	0.00	0	0.00	0
ROLL	-0.17	102	0.00	102	2.22	2.22	3.60	3.60
VSTRNA	0.02	85	0.02	85	0.42	0.42	0.24	0.24
VCGAC	0.03	149	0.03	149	0.21	0.21	0.09	0.09
TRCGAC	-0.01	87	-0.01	87	0.09	0.09	0.00	0.00

SEAWORTHINESS TEST RESULTS IN SEA STATE 4 (13 MAR 1980)

RUN 7 S. BEAM SEA, SES, APPROX. 17 KNOTS

313S07

CHRONOLOGICAL OUTPUT? 2 16		AVERAGE		AVE 1/3		AVE 1/10		EXTREME	
		PK	TR	PK	TR	FK	TR	PK	TR
PITCH	-2.47 -1.58 3.06 2.00 1.95 3.84 -0.23 2.47	1.82	-1.71	3.37	-3.27	4.38	-4.17	5.66	-5.86
	-3.63 -5.86 -3.24 0.80 -0.24 -1.03 -1.60 -2.05	3.60	-3.46	6.07	-6.15	7.59	-7.37	9.23	-9.62
FITCH	1.16 1.37 0.36 -0.11 2.57 4.44 2.73 2.00	0.23	-0.21	0.35	-0.37	0.43	-0.52	0.57	-0.76
	-1.16 -0.15 -2.05 -3.01 -2.21 -1.20 -1.84 -4.36	0.15	-0.04	0.25	-0.11	0.34	-0.16	0.60	-0.20
		0.13	-0.04	0.20	-0.10	0.23	-0.14	0.30	-0.24
		0.07	-0.11	0.09	-0.16	0.11	-0.19	0.12	-0.22

CHRONOLOGICAL OUTPUT? 3 16		RANKED OUTPUT?	
ROLL	9.08 -2.00 1.12 2.59 2.39 4.74 3.08 1.27	5.66	5.60 4.44 3.99 3.96 3.89 3.84 3.68
	-3.42 -6.01 -4.35 -1.17 -6.05 -1.51 -4.05 -2.73	-5.86	-4.38 -4.36 -4.07 -3.94 -3.71 -3.63 -3.40
ROLL	2.73 5.18 4.64 2.25 6.69 2.39 6.01 3.66	3.63	3.45 3.32 3.17 3.14 3.12 3.12 3.11
	-3.37 -6.01 2.83 -4.93 -5.71 -0.44 -4.79 -3.56	-3.32	-3.24 -3.22 -3.21 -3.17 -3.14 -3.11 -3.09

CHRONOLOGICAL OUTPUT? 4 16		RANKED OUTPUT?	
VBOWAC	0.29 0.23 0.33 0.36 0.10 0.33 0.18 0.16	9.23	9.08 7.42 7.32 7.18 6.88 6.88 6.69
	-0.34 -0.36 -0.13 -0.39 -0.13 -0.24 -0.13 -0.03	-9.62	-7.71 -7.67 -7.37 -7.18 -6.77 -6.40 -6.25
VBOWAC	0.21 0.31 0.24 0.18 0.10 0.29 0.29 0.16	6.35	6.25 6.15 6.01 6.01 5.96 5.91 5.62
	-0.10 -0.26 -0.41 -0.18 -0.10 -0.10 -0.23 -0.24	-6.20	-6.10 -6.05 -6.01 -6.01 -5.91 -5.81 -5.71

CHRONOLOGICAL OUTPUT? 5 16		RANKED OUTPUT?	
VSTRNA	0.19 0.28 0.37 0.21 0.23 0.17 0.07 0.24	0.57	0.55 0.47 0.46 0.46 0.44 0.44 0.42
	0.04 -0.05 -0.13 -0.14 0.09 -0.07 -0.16 -0.08	-0.76	-0.73 -0.62 -0.59 -0.59 -0.52 -0.50 -0.49
VSTRNA	0.22 0.17 0.24 0.20 0.14 0.07 0.11 0.15	0.41	0.39 0.37 0.37 0.37 0.37 0.36 0.36
	-0.07 0.05 -0.03 0.07 -0.05 -0.02 -0.04 -0.06	-0.46	-0.46 -0.44 -0.44 -0.44 -0.42 -0.41 -0.41

CHRONOLOGICAL OUTPUT? 6 16		RANKED OUTPUT?	
VCGAC	0.12 0.07 0.17 0.11 0.15 0.13 0.25 0.16	0.60	0.51 0.45 0.44 0.42 0.39 0.38 0.38
	0.00 -0.03 -0.06 -0.03 -0.05 0.02 -0.15 0.02	-0.20	-0.20 -0.20 -0.19 -0.19 -0.18 -0.18 -0.18
VCGAC	0.14 0.19 0.21 0.17 0.12 0.14 0.10 0.22	0.37	0.36 0.36 0.36 0.36 0.33 0.33 0.32
	-0.04 0.03 -0.15 0.01 0.00 -0.08 -0.03 -0.03	-0.18	-0.17 -0.17 -0.17 -0.17 -0.16 -0.16 -0.16

CHRONOLOGICAL OUTPUT? 7 17		RANKED OUTPUT?	
TRCGAC	0.02 0.10 0.08 0.07 0.05 0.05 0.08 0.10	0.30	0.27 0.26 0.26 0.25 0.24 0.24 0.24
	-0.15 -0.10 -0.06 -0.22 -0.11 -0.14 -0.09 -0.17	-0.24	-0.21 -0.20 -0.20 -0.18 -0.16 -0.16 -0.15
TRCGAC	0.08 0.03 0.10 0.07 0.05 0.09 0.05 0.05	0.24	0.24 0.23 0.23 0.23 0.23 0.23 0.23
	-0.03 -0.12 -0.16 -0.07 -0.07 -0.11 -0.08 -0.10	-0.15	-0.15 -0.15 -0.15 -0.14 -0.13 -0.13 -0.13

CHRONOLOGICAL OUTPUT? 7 16		RANKED OUTPUT?	
TRCGAC	0.12 0.12 0.11 0.11 0.11 0.11 0.10 0.10	0.12	0.12 0.11 0.11 0.11 0.11 0.10 0.10
	-0.22 -0.21 -0.20 -0.19 -0.18 -0.17 -0.17 -0.16	-0.22	-0.21 -0.20 -0.19 -0.18 -0.17 -0.17 -0.16
TRCGAC	0.10 0.10 0.10 0.09 0.09 0.09 0.09 0.09	0.10	0.10 0.10 0.09 0.09 0.09 0.09 0.09
	-0.16 -0.16 -0.16 -0.15 -0.15 -0.15 -0.15 -0.14	-0.16	-0.16 -0.16 -0.15 -0.15 -0.15 -0.15 -0.14

MEASUREMENT	MEAN VALUE	NO. OF PEAKS	RMS
PITCH	0.29	-1	0.00
ROLL	0.05	84	1.79
VBOWAC	0.17	80	3.14
VSTRNA	0.04	163	0.14
VCGAC	0.04	324	0.08
TRCGAC	0.05	321	0.07
TRCGAC	-0.02	77	0.06
TRCGAC	-0.04	-1	0.00

SEAWORTHINESS TEST RESULTS IN SEA STATE 4 (13 MAR 1980)

RUN 7 S.BEAM SEA, WPB, APPROX. 17 KNOTS

313W07

CHRONOLOGICAL OUTPUT?	AVERAGE		AVE 1/3		AVE 1/10		EXTREME	
	FK	TR	FK	TR	FK	TR	FK	TR
FITCH	1.70	-0.92	2.76	-1.96	3.29	-2.67	3.61	-3.99
ROLL	5.73	-5.49	10.83	-10.52	13.95	-14.22	17.09	-18.75
VEGWAC	0.29	-0.31	0.45	-0.48	0.58	-0.64	0.73	-0.88
VESTRNA	0.14	-0.19	0.23	-0.29	0.30	-0.38	0.40	-0.53
VEGAC	0.12	-0.18	0.20	-0.28	0.26	-0.35	0.33	-0.51
TRCGAC	0.14	-0.13	0.24	-0.21	0.31	-0.26	0.39	-0.32

RANKED OUTPUT? 2 16

FITCH	3.61	3.45	3.42	3.40	3.24	3.22	3.11	3.09
ROLL	-3.99	-2.82	-2.54	-2.52	-2.51	-2.46	-2.43	-2.38
FITCH	3.08	3.06	3.01	2.96	2.93	2.90	2.77	2.67
ROLL	-2.36	-2.36	-2.18	-2.10	-2.07	-2.00	-1.82	-1.79

RANKED OUTPUT? 3 16

ROLL	17.09	15.87	14.84	13.43	13.28	11.57	11.57	11.13
ROLL	-18.75	-18.02	-14.60	-13.57	-13.18	-10.79	-10.60	-10.55
ROLL	10.60	10.11	10.06	9.72	9.62	9.57	9.52	9.47
ROLL	-9.86	-9.42	-9.37	-9.28	-9.23	-9.18	-9.08	-8.84

RANKED OUTPUT? 4 16

VEGWAC	0.73	0.72	0.67	0.65	0.59	0.57	0.57	0.57
VEGWAC	-0.88	-0.85	-0.76	-0.73	-0.67	-0.65	-0.63	-0.60
VEGWAC	0.55	0.51	0.52	0.52	0.50	0.49	0.49	0.49
VEGWAC	-0.59	-0.57	-0.55	-0.54	-0.52	-0.52	-0.52	-0.50

RANKED OUTPUT? 5 16

VESTRNA	0.40	0.37	0.35	0.35	0.33	0.30	0.28	0.28
VESTRNA	-0.53	-0.43	-0.42	-0.42	-0.41	-0.39	-0.38	-0.37
VESTRNA	0.28	0.28	0.26	0.26	0.25	0.25	0.24	0.24
VESTRNA	-0.35	-0.34	-0.33	-0.33	-0.33	-0.32	-0.32	-0.32

RANKED OUTPUT? 6 16

VEGAC	0.33	0.32	0.31	0.28	0.26	0.26	0.26	0.25
VEGAC	-0.51	-0.45	-0.40	-0.40	-0.38	-0.36	-0.33	-0.33
VEGAC	0.24	0.24	0.24	0.23	0.23	0.23	0.23	0.22
VEGAC	-0.32	-0.31	-0.30	-0.29	-0.29	-0.29	-0.29	-0.28

RANKED OUTPUT? 7 16

TRCGAC	0.39	0.35	0.33	0.30	0.29	0.27	0.26	0.26
TRCGAC	-0.32	-0.28	-0.26	-0.25	-0.24	-0.24	-0.24	-0.23
TRCGAC	0.25	0.23	0.22	0.22	0.22	0.21	0.21	0.21
TRCGAC	-0.22	-0.22	-0.21	-0.20	-0.20	-0.20	-0.19	-0.19

CHRONOLOGICAL OUTPUT? 2 16

FITCH	1.12	1.50	1.81	2.77	3.42	1.60	0.67
FITCH	-0.16	-0.70	0.15	-0.33	-0.26	0.00	-1.38
FITCH	2.02	1.84	1.87	2.93	2.57	0.47	1.95
FITCH	-0.14	-0.85	0.24	0.15	1.51	-2.82	-1.53

CHRONOLOGICAL OUTPUT? 3 16

ROLL	9.03	11.57	0.00	2.78	-1.17	9.23	-1.37
ROLL	-1.66	-3.96	-2.78	-3.56	-6.69	-4.64	-16.75
ROLL	10.60	8.59	8.74	9.52	13.28	-4.15	2.34
ROLL	-2.25	-6.20	-18.02	-8.74	-2.49	-5.71	-6.01

CHRONOLOGICAL OUTPUT? 4 16

VEGWAC	0.28	0.28	0.21	0.20	0.26	0.21	0.23
VEGWAC	-0.37	-0.24	-0.11	-0.34	-0.23	-0.16	-0.24
VEGWAC	0.59	0.72	0.16	0.29	0.26	0.46	0.11
VEGWAC	-0.50	-0.55	-0.60	-0.18	-0.31	-0.42	-0.24

CHRONOLOGICAL OUTPUT? 5 16

VESTRNA	0.06	0.15	0.06	0.13	0.14	0.07	0.15
VESTRNA	-0.18	-0.15	-0.07	-0.22	-0.10	-0.03	-0.11
VESTRNA	0.25	0.17	0.35	0.13	0.18	0.33	0.20
VESTRNA	-0.24	-0.37	-0.15	-0.26	-0.17	-0.34	-0.11

CHRONOLOGICAL OUTPUT? 6 16

VEGAC	0.07	0.11	0.08	0.07	0.11	0.11	0.06
VEGAC	-0.19	-0.14	-0.07	-0.24	-0.14	-0.10	-0.15
VEGAC	0.13	0.32	0.02	0.10	0.15	0.23	0.00
VEGAC	-0.30	-0.29	-0.27	-0.17	-0.18	-0.24	-0.13

CHRONOLOGICAL OUTPUT? 7 16

MEAN VALUE	NO. OF PEAKS	RMS
AVEHT	0.00	0.00
FITCH	0.39	1.22
ROLL	0.31	5.72
VEGWAC	-0.01	153
VESTRNA	-0.02	150
VEGAC	-0.03	140
TRCGAC	-0.00	73
TRCGAC	-0.02	0

## RUN 8 FOLLOWING SEA, SES, APPROX 19 KNOTS

313S08

	CHRONOLOGICAL OUTPUT†		2 16		AVERAGE		AVE 1/3		AVE 1/10		EXTREME					
	PK	TR	PK	TR	PK	TR	PK	TR	PK	TR	PK	TR				
PITCH	2.13	0.31	0.68	3.45	4.00	1.14	5.32	-0.67	2.24	-2.66	4.03	-4.60	4.75	-5.48	5.32	-6.18
ROLL	-4.41	-1.60	-0.91	-1.63	-4.77	-0.93	-0.11	-6.18	1.64	-1.98	3.24	-3.55	4.25	-4.56	4.64	-5.18
PITCH	4.18	1.09	1.90	3.96	3.45	-0.85	-0.88	2.43	0.16	-0.08	0.19	-0.11	0.21	-0.15	0.21	-0.18
ROLL	-3.65	-2.52	-1.97	-2.51	-4.65	-3.63	-2.36	-1.89	0.11	-0.02	0.14	-0.05	0.17	-0.07	0.20	-0.13
									0.13	-0.01	0.13	-0.03	0.14	-0.06	0.17	-0.08
									0.05	-0.10	0.08	-0.12	0.11	-0.15	0.11	-0.15
									RANKED OUTPUT†				2 16			
PITCH	2.39	2.39	3.08	-0.73	4.05	2.44	-1.46	2.83	5.32	4.18	4.00	3.96	3.84	3.45	3.45	3.34
ROLL	-3.86	-0.63	1.32	-4.10	-1.81	-0.68	-2.98	-3.81	-6.18	-4.77	-4.74	-4.65	-4.41	-3.82	-3.65	-3.63
PITCH	4.64	2.10	3.27	2.10	0.20	4.15	1.95	-0.93	3.21	3.17	2.91	2.43	2.13	1.90	1.14	1.11
ROLL	-4.49	-4.10	0.20	-1.86	-1.76	-2.25	-1.86	-3.32	-2.52	-2.51	-2.36	-2.16	-1.97	-1.89	-1.79	-1.77
									RANKED OUTPUT†				3 16			
PITCH	0.13	0.15	0.21	0.15	0.15	0.16	0.15	0.13	4.64	4.44	4.25	4.15	4.05	3.96	3.76	3.66
ROLL	-0.08	-0.08	-0.07	-0.07	-0.05	-0.07	-0.05	-0.10	-5.18	-4.93	-4.54	-4.49	-4.10	-3.96	-3.96	-3.86
PITCH	0.15	0.18	0.15	0.16	0.15	0.15	0.15	0.15	3.32	3.27	3.17	3.17	3.08	2.93	2.83	2.73
ROLL	-0.08	-0.05	-0.11	-0.18	-0.08	-0.07	-0.07	-0.05	-3.81	-3.81	-3.61	-3.47	-3.32	-3.22	-3.08	-2.98
									RANKED OUTPUT†				4 16			
PITCH	0.10	0.11	0.13	0.11	0.11	0.11	0.13	0.12	0.21	0.21	0.21	0.20	0.18	0.18	0.16	0.16
ROLL	0.00	0.00	-0.03	0.02	-0.02	-0.02	-0.02	0.02	-0.18	-0.13	-0.11	-0.11	-0.10	-0.10	-0.08	-0.08
PITCH	0.11	0.11	0.15	0.11	0.20	0.11	0.11	0.08	0.16	0.16	0.15	0.15	0.15	0.15	0.15	0.15
ROLL	0.00	-0.05	-0.02	-0.04	-0.02	-0.04	0.02	-0.02	-0.08	-0.08	-0.08	-0.08	-0.07	-0.07	-0.07	-0.07
									RANKED OUTPUT†				5 16			
PITCH	0.11	0.11	0.12	0.13	0.12	0.12	0.11	0.09	0.20	0.20	0.19	0.19	0.19	0.16	0.16	0.15
ROLL	0.01	0.00	-0.03	0.00	0.00	0.00	-0.02	-0.02	-0.13	-0.11	-0.09	-0.09	-0.09	-0.07	-0.07	-0.06
PITCH	0.13	0.11	0.14	0.12	0.13	0.10	0.08	0.10	0.15	0.15	0.15	0.15	0.15	0.15	0.15	0.15
ROLL	-0.02	0.01	0.00	0.00	0.02	0.00	-0.02	-0.03	-0.06	-0.06	-0.06	-0.05	-0.05	-0.05	-0.05	-0.05
									RANKED OUTPUT†				6 16			
PITCH	0.07	0.01	0.05	0.05	0.06	0.01	0.05	0.07	0.17	0.15	0.14	0.14	0.13	0.13	0.12	0.13
ROLL	-0.12	-0.08	-0.10	-0.09	-0.09	-0.09	-0.10	-0.10	-0.08	-0.07	-0.07	-0.06	-0.06	-0.03	-0.03	-0.03
PITCH	0.11	-0.00	0.03	0.06	0.03	0.03	0.04	0.06	0.13	0.13	0.13	0.13	0.12	0.12	0.12	0.12
ROLL	-0.05	-0.12	-0.15	-0.09	-0.08	-0.11	-0.09	-0.06	-0.03	-0.03	-0.02	-0.02	-0.02	-0.02	-0.02	-0.02
									RANKED OUTPUT†				7 16			
MEAN VALUE	0.26	0.00	0	0.00	0.00	0.00	0.00	0.00	0.11	0.10	0.07	0.07	0.07	0.07	0.06	0.06
PITCH	-0.10	2.09	22	2.09	2.09	2.09	2.09	2.09	-0.15	-0.15	-0.13	-0.13	-0.12	-0.12	-0.11	-0.11
ROLL	0.02	1.75	69	1.75	1.75	1.75	1.75	1.75	0.06	0.06	0.05	0.05	0.05	0.05	0.05	0.04
PITCH	0.04	0.04	27	0.04	0.04	0.04	0.04	0.04	0.06	0.06	0.05	0.05	0.05	0.05	0.05	0.04
ROLL	0.05	0.05	140	0.05	0.05	0.05	0.05	0.05	-0.10	-0.10	-0.10	-0.10	-0.09	-0.09	-0.09	-0.09
PITCH	0.05	0.05	76	0.05	0.05	0.05	0.05	0.05	0.06	0.06	0.06	0.06	0.06	0.06	0.06	0.06
ROLL	-0.03	0.04	27	0.04	0.04	0.04	0.04	0.04	-0.03	-0.03	-0.03	-0.03	-0.03	-0.03	-0.03	-0.03
PITCH	-0.04	0.00	0	0.00	0.00	0.00	0.00	0.00	0.06	0.06	0.06	0.06	0.06	0.06	0.06	0.06
ROLL	0.04	0.00	0	0.00	0.00	0.00	0.00	0.00	0.04	0.04	0.04	0.04	0.04	0.04	0.04	0.04

SEAWORTHINESS TEST RESULTS IN SEA STATE 4 (13 MAR 1980)

RUN 8 FOLLOWING SEA, WPB, 17 KNOTS

313W08

CHRONOLOGICAL OUTPUT?		2 16		AVERAGE		AVE 1/3		AVE 1/10		EXTREME	
		FA	TR	PK	TR	PK	TR	PK	TR	PK	TR
PITCH	2.43	2.39	4.05	3.84	1.25	4.02	1.66	2.98			
	-0.67	1.71	2.02	-1.63	-1.76	-0.42	-6.48	-3.18			
ROLL	2.72	0.83	0.94	1.24	2.65	-0.46	3.24	2.98			
	-3.17	-4.12	-0.41	-1.07	-1.20	-2.90	-1.46	-4.17			
CHRONOLOGICAL OUTPUT?		3 16		RANKED OUTPUT?		2 16					
ROLL	13.53	6.59	7.23	3.76	8.59	4.30	0.39	10.99			
	-14.75	-1.07	-11.87	-13.67	-6.15	-0.05	-9.72	-7.13			
ROLL	11.28	-1.32	-2.10	14.26	2.59	17.97	2.44	-0.98			
	-0.15	-7.18	-5.37	-6.01	-2.88	-7.52	-1.37	-17.14			
CHRONOLOGICAL OUTPUT?		4 16		RANKED OUTPUT?		3 16					
VEGWAC	0.07	0.16	0.10	0.05	0.10	0.05	0.10	0.10			
	-0.16	-0.18	-0.11	-0.13	-0.11	-0.15	-0.15	-0.15			
VEGWAC	0.08	0.08	0.15	0.20	0.05	0.11	0.10	0.08			
	-0.15	-0.15	-0.16	-0.08	-0.15	-0.16	-0.11	-0.15			
CHRONOLOGICAL OUTPUT?		5 16		RANKED OUTPUT?		4 16					
VESTRNA	0.01	0.03	0.03	0.04	0.02	0.02	0.02	0.06			
	-0.10	-0.11	-0.08	-0.07	-0.07	-0.08	-0.11	-0.11			
VESTRNA	0.02	0.07	0.04	0.03	0.04	0.03	0.01	0.06			
	-0.10	-0.10	-0.07	-0.07	-0.11	-0.07	-0.12	-0.09			
CHRONOLOGICAL OUTPUT?		6 16		RANKED OUTPUT?		5 16					
VEGCAC	0.03	0.05	0.02	0.00	0.00	0.05	0.02	0.05			
	-0.13	-0.11	-0.11	-0.10	-0.10	-0.10	-0.09	-0.12			
VEGCAC	0.04	0.02	0.05	0.00	0.06	-0.02	0.01	0.02			
	-0.07	-0.15	-0.12	-0.10	-0.10	-0.11	-0.15	-0.11			
CHRONOLOGICAL OUTPUT?		7 16		RANKED OUTPUT?		6 16					
TRCGAC	-0.02	0.24	0.21	0.06	0.12	0.13	-0.04	0.09			
	-0.31	-6.17	-0.20	-0.09	-0.21	-0.08	-0.31	-0.25			
TRCGAC	0.05	0.07	0.12	0.05	0.31	0.08	0.04	0.15			
	-0.05	-0.31	-0.11	-0.41	-0.07	-0.05	-0.34	-0.11			
MEAN VALUE		NO. OF PEAKS		RMS							
WAVEHT	0.00	0	0	0.00	0.00	0.00	0.00	0.00			
PITCH	-0.15	22	22	1.92	1.92	1.92	1.92	1.92			
ROLL	-0.05	63	63	6.44	6.44	6.44	6.44	6.44			
VEGWAC	-0.02	37	37	0.05	0.05	0.05	0.05	0.05			
VESTRNA	-0.03	64	64	0.03	0.03	0.03	0.03	0.03			
VEGCAC	-0.04	45	45	0.03	0.03	0.03	0.03	0.03			
TRCGAC	-0.05	50	50	0.13	0.13	0.13	0.13	0.13			
LMCGAC	-0.03	0	0	0.00	0.00	0.00	0.00	0.00			

SEAWORTHINESS TEST RESULTS IN SEA STATE 4 (13 MAR 1980)

RUN 9 P. BOW SEA, SES, APPROX. 17 KNOTS

313S09

CHRONOLOGICAL OUTPUT	AVERAGE				AVE 1/3				AVE 1/10				EXTREME			
	PK	TR	PK	TR	PK	TR	PK	TR	PK	TR	PK	TR	PK	TR	PK	TR
PITCH	1.71	1.42	4.61	1.82	1.77	5.45	6.11	1.87	3.28	-3.28	5.34	-5.25	6.67	-7.10	7.84	-7.31
ROLL	-3.32	-1.48	-4.75	-4.61	-1.14	-1.90	-5.40	-3.06	3.54	-3.33	5.80	-5.60	7.53	-7.21	10.25	-9.96
VSTRNA	1.64	2.98	3.24	5.47	5.26	2.95	4.35	3.32	0.31	-0.34	0.56	-0.69	0.74	-0.94	1.38	-1.37
VCGAC	-1.92	2.75	-1.90	-3.71	-4.39	-2.57	-5.42	-5.42	0.22	-0.08	0.46	-0.25	0.69	-0.37	1.04	-0.57
TRCGAL	0.17	-0.06	0.28	-0.20	0.36	-0.20	0.36	-0.33	0.17	-0.06	0.28	-0.20	0.36	-0.33	0.55	-0.62
TRCGAL	0.07	-0.11	0.12	-0.15	0.15	-0.15	0.15	-0.19	0.07	-0.11	0.12	-0.15	0.15	-0.19	0.17	-0.25

CHRONOLOGICAL OUTPUT	2 16
PITCH	7.86 7.58 7.19 6.80 6.77 6.38 6.32 6.14
ROLL	-7.31 -7.91 -7.52 -7.41 -7.15 -6.49 -6.38 -6.36
PITCH	5.96 5.68 5.47 5.45 5.45 5.26 5.26 5.26
ROLL	-6.23 -6.22 -5.55 -5.42 -5.40 -5.39 -5.39 -5.09

CHRONOLOGICAL OUTPUT	3 16
ROLL	10.25 9.13 8.45 8.45 7.32 6.59 6.54 6.45
ROLL	-9.96 -8.40 -8.11 -7.03 -6.64 -6.54 -6.49 -6.40
ROLL	6.20 5.91 5.81 5.76 5.71 5.57 5.47 5.42
ROLL	-6.35 -6.15 -6.15 -6.05 -6.05 -5.76 -5.62 -5.57

CHRONOLOGICAL OUTPUT	4 16
VSTRNA	1.38 1.03 0.93 0.91 0.88 0.78 0.75 0.72
VSTRNA	-1.37 -1.27 -1.24 -1.17 -1.11 -1.01 -0.99 -0.98
VSTRNA	0.68 0.68 0.68 0.68 0.68 0.67 0.65 0.63
VSTRNA	-0.94 -0.90 -0.90 -0.90 -0.90 -0.88 -0.85 -0.83

CHRONOLOGICAL OUTPUT	5 16
VSTRNA	1.04 1.01 0.97 0.93 0.90 0.85 0.85 0.81
VSTRNA	-0.57 -0.54 -0.46 -0.46 -0.46 -0.45 -0.44 -0.43
VSTRNA	0.81 0.77 0.77 0.76 0.75 0.74 0.73 0.72
VSTRNA	-0.42 -0.42 -0.42 -0.41 -0.38 -0.37 -0.37 -0.37

CHRONOLOGICAL OUTPUT	6 16
VCGAC	0.55 0.52 0.50 0.42 0.42 0.41 0.40 0.40
VCGAC	-0.62 -0.54 -0.53 -0.53 -0.51 -0.50 -0.49 -0.45
VCGAC	0.40 0.39 0.38 0.36 0.37 0.37 0.37 0.36
VCGAC	-0.41 -0.40 -0.34 -0.34 -0.33 -0.33 -0.31 -0.31

CHRONOLOGICAL OUTPUT	7 16
TRCGAC	0.17 0.16 0.16 0.16 0.15 0.15 0.15 0.14
TRCGAC	-0.75 -0.20 -0.19 -0.19 -0.18 -0.17 -0.17 -0.17
TRCGAC	0.14 0.13 0.13 0.13 0.13 0.12 0.12 0.12
TRCGAC	-0.15 -0.16 -0.16 -0.15 -0.15 -0.15 -0.15 -0.14

MEAN VALUE	NO. OF PEAKS	RMS
PITCH	0	0.00
ROLL	100	2.63
VSTRNA	101	2.84
VCGAC	238	0.16
VSTRNA	383	0.12
VCGAC	397	0.06
TRCGAC	97	0.00

SEAWORTHINESS TEST RESULTS IN SEA STATE 4 (13 MAR 1980)

313W09

RUN 9 P.BOW SEA, WPB, APPROX. 17 KNOTS

CHRONOLOGICAL OUTPUT*		2 16		3 16		4 16		5 16		6 16		7 16		RMS	
	MEAN VALUE		NO. OF PEAKS		NO. OF PEAKS		NO. OF PEAKS		NO. OF PEAKS		NO. OF PEAKS		NO. OF PEAKS		NO. OF PEAKS
PITCH	3.22	2.31	2.46	3.04	1.97	1.73	4.07	4.88	4.88	4.88	4.88	4.88	4.88	4.88	1.86
ROLL	-3.92	-1.32	-1.56	-2.86	-3.61	-0.50	-2.70	-2.83	-2.83	-2.83	-2.83	-2.83	-2.83	-2.83	5.11
PITCH	1.84	3.39	3.22	0.49	1.95	1.43	1.82	2.00	2.00	2.00	2.00	2.00	2.00	2.00	0.34
ROLL	-3.82	0.07	-3.87	-0.90	-2.59	0.11	-2.15	-0.46	-0.46	-0.46	-0.46	-0.46	-0.46	-0.46	0.20
CHRONOLOGICAL OUTPUT*		3 16		4 16		5 16		6 16		7 16		8 16		0.18	
ROLL	13.82	9.37	10.74	0.73	6.74	4.00	3.91	7.23	7.23	7.23	7.23	7.23	7.23	7.23	0.11
ROLL	-14.11	-13.57	-11.33	-2.93	-1.32	-1.86	-6.49	-7.08	-7.08	-7.08	-7.08	-7.08	-7.08	-7.08	0.11
ROLL	12.06	11.04	8.94	8.94	7.08	2.25	4.20	2.64	2.64	2.64	2.64	2.64	2.64	2.64	0.11
ROLL	-10.21	-4.98	-6.84	-6.10	-5.91	-7.86	-4.10	-2.29	-2.29	-2.29	-2.29	-2.29	-2.29	-2.29	0.11
CHRONOLOGICAL OUTPUT*		4 16		5 16		6 16		7 16		8 16		9 16		0.00	
VPOMAC	0.70	0.24	0.44	0.41	0.46	0.63	0.42	1.25	1.25	1.25	1.25	1.25	1.25	1.25	0.00
VPOMAC	-0.80	-0.08	-0.23	-0.42	-0.02	-0.49	0.07	-0.75	-0.75	-0.75	-0.75	-0.75	-0.75	-0.75	0.00
VPOMAC	0.55	0.72	0.07	0.50	1.01	0.55	1.12	0.57	0.57	0.57	0.57	0.57	0.57	0.57	0.00
VPOMAC	-0.65	-0.16	-0.39	-0.15	-0.68	-0.42	-0.86	-0.68	-0.68	-0.68	-0.68	-0.68	-0.68	-0.68	0.00
CHRONOLOGICAL OUTPUT*		5 16		6 16		7 16		8 16		9 16		10 16		0.00	
USTRNA	0.57	0.18	0.33	0.37	0.25	0.42	0.36	0.62	0.62	0.62	0.62	0.62	0.62	0.62	0.00
USTRNA	-0.43	-0.02	-0.15	-0.23	-0.26	0.10	-0.29	-0.47	-0.47	-0.47	-0.47	-0.47	-0.47	-0.47	0.00
USTRNA	0.28	0.42	0.15	0.10	0.36	0.46	0.33	0.57	0.57	0.57	0.57	0.57	0.57	0.57	0.00
USTRNA	-0.14	-0.09	0.00	-0.15	-0.06	-0.44	-0.03	-0.50	-0.50	-0.50	-0.50	-0.50	-0.50	-0.50	0.00
CHRONOLOGICAL OUTPUT*		6 16		7 16		8 16		9 16		10 16		11 16		0.00	
VCGAC	0.37	0.22	0.10	0.23	0.24	0.20	0.44	0.22	0.22	0.22	0.22	0.22	0.22	0.22	0.00
VCGAC	-0.52	-0.20	-0.17	-0.02	-0.24	0.07	-0.50	-0.23	-0.23	-0.23	-0.23	-0.23	-0.23	-0.23	0.00
VCGAC	0.33	-0.02	0.18	0.40	0.23	0.46	0.15	0.24	0.24	0.24	0.24	0.24	0.24	0.24	0.00
VCGAC	-0.15	-0.12	-0.13	-0.46	-0.15	-0.46	-0.24	-0.30	-0.30	-0.30	-0.30	-0.30	-0.30	-0.30	0.00
CHRONOLOGICAL OUTPUT*		7 16		8 16		9 16		10 16		11 16		12 16		0.00	
TRCGAC	0.25	0.22	0.14	0.06	0.06	0.17	0.14	0.17	0.17	0.17	0.17	0.17	0.17	0.17	0.00
TRCGAC	-0.24	-0.22	-0.25	-0.14	-0.16	-0.10	-0.14	-0.03	-0.03	-0.03	-0.03	-0.03	-0.03	-0.03	0.00
TRCGAC	0.19	0.04	0.14	0.10	0.15	0.08	0.26	0.16	0.16	0.16	0.16	0.16	0.16	0.16	0.00
TRCGAC	-0.17	-0.34	-0.15	-0.25	-0.22	-0.25	-0.32	-0.10	-0.10	-0.10	-0.10	-0.10	-0.10	-0.10	0.00
CHRONOLOGICAL OUTPUT*		8 16		9 16		10 16		11 16		12 16		13 16		0.00	
WAVEHT	0.00	0.00	0.00	0.00	0.00	0.00	0.00	0.00	0.00	0.00	0.00	0.00	0.00	0.00	0.00
PITCH	-0.02	-0.02	-0.02	-0.02	-0.02	-0.02	-0.02	-0.02	-0.02	-0.02	-0.02	-0.02	-0.02	-0.02	0.00
ROLL	-0.19	-0.19	-0.19	-0.19	-0.19	-0.19	-0.19	-0.19	-0.19	-0.19	-0.19	-0.19	-0.19	-0.19	0.00
VPOMAC	0.05	0.05	0.05	0.05	0.05	0.05	0.05	0.05	0.05	0.05	0.05	0.05	0.05	0.05	0.00
USTRNA	0.04	0.04	0.04	0.04	0.04	0.04	0.04	0.04	0.04	0.04	0.04	0.04	0.04	0.04	0.00
VCGAC	-0.01	-0.01	-0.01	-0.01	-0.01	-0.01	-0.01	-0.01	-0.01	-0.01	-0.01	-0.01	-0.01	-0.01	0.00
TRCGAC	-0.04	-0.04	-0.04	-0.04	-0.04	-0.04	-0.04	-0.04	-0.04	-0.04	-0.04	-0.04	-0.04	-0.04	0.00
LNGCAC	0.01	0.01	0.01	0.01	0.01	0.01	0.01	0.01	0.01	0.01	0.01	0.01	0.01	0.01	0.00

SEAWORTHINESS TEST RESULTS IN SEA STATE 4 (13 MAR 1980)

RUN 10 P. QUARTERING SEA, SES, APPROX. 18 KNOTS

313S10

CHRONOLOGICAL OUTPUT#		2 16		AVERAGE		AVE 1/3		AVE 1/10		EXTREME			
		FK	TR	FK	TR	FK	TR	FK	TR	FK	TR		
PITCH	2.10	1.60	0.36	0.63	1.20	-0.29	4.05	4.12	4.12	4.37	-3.84	5.49	-4.10
ROLL	-2.20	-0.55	-0.93	-0.88	-2.72	-1.38	-3.40	-4.10	-4.10	5.57	-5.32	6.93	-7.02
										0.24	-0.16	0.28	-0.29
										0.17	-0.07	0.20	-0.11
										0.16	-0.06	0.18	-0.09
										0.10	-0.14	0.13	-0.13

CHRONOLOGICAL OUTPUT#		3 16		RANKED OUTPUT#		2 16		
ROLL	0.05	5.47	2.49	6.25	4.39	3.03	4.49	9.13
	-1.46	-2.83	-5.57	-6.25	-0.93	-3.56	-3.71	-5.08
ROLL	4.59	1.95	2.69	1.22	3.71	6.74	1.86	-0.59
	-3.96	-2.93	-4.93	-0.29	-3.42	-3.52	-3.37	-1.71

CHRONOLOGICAL OUTPUT#		4 16		RANKED OUTPUT#		3 16		
VRWAC	0.23	0.16	0.13	0.24	0.20	0.16	0.26	0.21
	-0.08	-0.13	-0.07	-0.08	-0.11	-0.15	-0.08	-0.11
VRWAC	0.24	0.15	0.16	0.13	0.20	0.21	0.15	0.16
	-0.15	-0.15	-0.07	-0.08	-0.29	-0.07	-0.07	-0.07

CHRONOLOGICAL OUTPUT#		5 16		RANKED OUTPUT#		4 16		
VSTRNA	0.17	0.11	0.16	0.08	0.16	0.12	0.08	0.11
	0.03	0.02	-0.02	-0.07	-0.04	0.01	-0.04	-0.06
VSTRNA	0.16	0.07	0.15	0.15	0.13	0.18	0.17	0.16
	-0.02	-0.06	-0.02	-0.10	0.00	0.03	0.05	-0.05

CHRONOLOGICAL OUTPUT#		6 16		RANKED OUTPUT#		5 16		
VEGAC	0.12	0.14	0.11	0.11	0.16	0.15	0.10	0.19
	-0.04	-0.11	0.01	-0.03	-0.02	-0.01	-0.13	0.00
VEGAC	0.14	0.13	0.14	0.15	0.08	0.11	0.15	0.14
	-0.07	-0.05	-0.03	0.00	-0.05	-0.02	-0.02	-0.10

CHRONOLOGICAL OUTPUT#		7 16		RANKED OUTPUT#		6 16		
TRCGAC	0.11	0.09	0.08	0.05	0.09	0.05	0.14	0.02
	-0.13	-0.19	-0.09	-0.10	-0.06	-0.08	-0.15	-0.13
TRCGAC	0.08	0.09	0.05	0.02	0.07	0.13	0.04	0.06
	-0.11	-0.15	-0.16	-0.08	-0.08	-0.11	-0.11	-0.11

	MEAN VALUE	NO. OF PEAKS	RMS
WAVERT	0.22	0	0.00
PITCH	0.02	40	1.66
ROLL	-0.00	86	2.77
VRWAC	0.04	90	0.08
VSTRNA	0.05	135	0.05
VEGAC	0.05	100	0.04
TRCGAC	-0.03	71	0.05
TRCGAC	-0.05	0	0.00

SEAWORTHINESS TEST RESULTS IN SEA STATE 4 (13 MAR 1980)

RUN 10 P. QUARTERING SEA, WPB, APPROX. 17 KNOTS

313W10

	CHRONOLOGICAL OUTPUT?		2 16		AVERAGE		AVE 1/3		AVE 1/10		EXTREME					
	PK	TR	PK	TR	PK	TR	PK	TR	PK	TR	PK	TR				
PITCH	3.91	7.03	1.63	0.99	3.35	2.21	2.12	3.29	1.67	-1.13	2.92	-2.07	3.57	-2.55	3.91	-2.77
ROLL	-0.31	-2.41	-2.16	-0.23	-2.05	-1.66	1.11	4.42	-6.57	10.78	-11.88	-0.29	15.38	-15.35	18.75	-17.53
UPQWAC	0.21	-0.20	0.32	-0.29	0.18	-0.20	0.23	0.23	0.21	-0.20	0.18	-0.20	0.23	-0.25	0.35	-0.38
USTRNA	0.12	0.13	2.73	2.12	0.11	0.26	0.26	0.09	0.09	-0.15	0.15	-0.21	0.20	-0.25	0.32	-0.32
VC6GAC	0.09	-0.15	0.17	-1.95	-1.66	-1.38	0.09	0.09	0.09	-0.19	0.17	-0.30	0.22	-0.40	0.28	-0.50
TRCGAC	0.09	-0.19	0.17	-0.30	0.29	-0.29	0.16	0.16	0.16	0.16	0.16	0.16	0.16	0.16	0.16	0.16
RANKED OUTPUT? 2 16																
PITCH	3.91	3.79	3.52	3.35	3.29	3.03	3.03	3.03	3.03	3.27	3.03	3.03	3.27	3.03	3.03	3.03
ROLL	-2.77	-2.62	-2.52	-2.44	-2.41	-2.34	-2.18	-2.18	-2.18	-2.34	-2.25	-2.18	-2.34	-2.25	-2.18	-2.18
UPQWAC	2.96	2.86	2.85	2.77	2.73	2.51	2.47	2.47	2.47	2.77	2.73	2.51	2.77	2.73	2.49	2.47
USTRNA	-2.16	-2.05	-1.95	-1.94	-1.73	-1.69	-1.68	-1.68	-1.68	-1.94	-1.73	-1.69	-1.73	-1.69	-1.69	-1.68
RANKED OUTPUT? 3 16																
FCLL	18.75	16.75	16.06	15.19	14.89	13.04	12.40	12.40	12.40	16.75	16.06	15.19	14.89	13.04	12.99	12.40
ROLL	-17.53	-16.70	-16.36	-15.04	-14.79	-13.72	-13.28	-13.28	-13.28	-16.70	-16.36	-15.04	-14.79	-13.72	-13.33	-13.28
UPQWAC	12.35	11.33	10.89	10.69	10.60	9.96	9.08	9.08	9.08	11.33	10.89	10.69	10.60	9.96	9.96	9.08
USTRNA	-12.40	-11.96	-11.67	-11.38	-11.13	-10.94	-10.64	-10.64	-10.64	-11.96	-11.67	-11.38	-11.13	-10.94	-10.69	-10.64
RANKED OUTPUT? 4 16																
UPQWAC	0.57	0.46	0.46	0.42	0.41	0.37	0.37	0.37	0.37	0.46	0.42	0.41	0.41	0.41	0.37	0.37
USTRNA	-0.47	-0.46	-0.39	-0.37	-0.37	-0.36	-0.34	-0.34	-0.34	-0.46	-0.39	-0.37	-0.37	-0.37	-0.36	-0.34
UPQWAC	0.37	0.37	0.36	0.36	0.36	0.36	0.36	0.36	0.36	0.37	0.36	0.36	0.36	0.36	0.36	0.36
USTRNA	-0.34	-0.34	-0.33	-0.31	-0.31	-0.29	-0.29	-0.29	-0.29	-0.34	-0.33	-0.31	-0.31	-0.29	-0.29	-0.29
RANKED OUTPUT? 5 16																
USTRNA	0.35	0.26	0.24	0.24	0.23	0.21	0.21	0.21	0.21	0.35	0.26	0.24	0.23	0.23	0.21	0.21
VC6GAC	-0.38	-0.30	-0.28	-0.25	-0.25	-0.24	-0.24	-0.24	-0.24	-0.38	-0.28	-0.25	-0.25	-0.24	-0.24	-0.24
USTRNA	0.20	0.20	0.20	0.20	0.20	0.20	0.20	0.20	0.20	0.20	0.20	0.20	0.20	0.20	0.18	0.18
VC6GAC	-0.24	-0.23	-0.22	-0.22	-0.21	-0.21	-0.20	-0.20	-0.20	-0.24	-0.23	-0.23	-0.23	-0.21	-0.20	-0.20
RANKED OUTPUT? 6 16																
VC6GAC	0.32	0.24	0.22	0.20	0.20	0.19	0.18	0.16	0.16	0.32	0.24	0.22	0.20	0.20	0.19	0.18
TRCGAC	-0.32	-0.26	-0.25	-0.24	-0.24	-0.24	-0.24	-0.24	-0.24	-0.32	-0.26	-0.25	-0.24	-0.24	-0.24	-0.24
VC6GAC	0.16	0.16	0.16	0.16	0.15	0.15	0.15	0.15	0.15	0.16	0.16	0.16	0.15	0.15	0.15	0.15
TRCGAC	-0.24	-0.24	-0.23	-0.23	-0.23	-0.23	-0.22	-0.22	-0.22	-0.24	-0.23	-0.23	-0.23	-0.23	-0.22	-0.22
RANKED OUTPUT? 7 16																
VC6GAC	0.28	0.23	0.23	0.22	0.21	0.20	0.20	0.18	0.18	0.28	0.23	0.23	0.22	0.21	0.20	0.20
TRCGAC	-0.50	-0.44	-0.43	-0.40	-0.37	-0.33	-0.32	-0.32	-0.32	-0.50	-0.44	-0.43	-0.40	-0.37	-0.33	-0.32
VC6GAC	0.18	0.18	0.17	0.17	0.17	0.16	0.15	0.15	0.15	0.18	0.18	0.17	0.17	0.16	0.15	0.15
TRCGAC	-0.31	-0.31	-0.30	-0.29	-0.29	-0.28	-0.26	-0.26	-0.26	-0.31	-0.31	-0.29	-0.29	-0.28	-0.26	-0.26
RANKED OUTPUT? 8 16																
VC6GAC	0.00	0.00	0.00	0.00	0.00	0.00	0.00	0.00	0.00	0.00	0.00	0.00	0.00	0.00	0.00	0.00
PITCH	0.28	0.28	0.28	0.28	0.28	0.28	0.28	0.28	0.28	0.28	0.28	0.28	0.28	0.28	0.28	0.28
ROLL	-0.35	-0.35	-0.35	-0.35	-0.35	-0.35	-0.35	-0.35	-0.35	-0.35	-0.35	-0.35	-0.35	-0.35	-0.35	-0.35
UPQWAC	0.01	0.01	0.01	0.01	0.01	0.01	0.01	0.01	0.01	0.01	0.01	0.01	0.01	0.01	0.01	0.01
USTRNA	-0.00	-0.00	-0.00	-0.00	-0.00	-0.00	-0.00	-0.00	-0.00	-0.00	-0.00	-0.00	-0.00	-0.00	-0.00	-0.00
VC6GAC	0.03	0.03	0.03	0.03	0.03	0.03	0.03	0.03	0.03	0.03	0.03	0.03	0.03	0.03	0.03	0.03
TRCGAC	-0.07	-0.07	-0.07	-0.07	-0.07	-0.07	-0.07	-0.07	-0.07	-0.07	-0.07	-0.07	-0.07	-0.07	-0.07	-0.07
LXCGAC	-0.02	-0.02	-0.02	-0.02	-0.02	-0.02	-0.02	-0.02	-0.02	-0.02	-0.02	-0.02	-0.02	-0.02	-0.02	-0.02

SEAWORTHINESS TEST RESULTS IN SEA STATE 4 (13 MAR 1980)

313S11

RUN 11 HEAD SEA, SES, APPROX. 26 KNOTS

CHRONOLOGICAL OUTPUT 2 16

	AVERAGE		AVE 1/3		AVE 1/10		EXTREME	
	PK	TR	PK	TR	PK	TR	PK	TR
PITCH	3.24	5.89	4.17	2.23	2.12	2.56	5.57	4.54
ROLL	-7.54	-3.35	-2.23	-2.34	0.16	0.05	-3.32	-5.08
VBOWAC	3.06	0.55	2.99	1.32	4.92	3.21	4.61	4.57
VSTRNA	-1.94	-1.27	-0.73	-3.17	-0.60	-6.25	-4.28	-4.15
VCGAC	0.32	0.18	0.51	-0.36	0.72	-0.48	1.47	-0.49
TRCGAC	0.08	-0.11	0.12	-0.16	0.15	-0.20	0.18	-0.27

RANKED OUTPUT 2 16

PITCH	9.51	7.83	6.38	6.38	6.33	6.10	6.07	5.92
ROLL	-8.07	-7.55	-7.54	-7.44	-6.92	-6.59	-6.51	-6.49
VBOWAC	5.89	5.86	5.83	5.57	5.53	5.49	5.47	5.40
VSTRNA	-6.25	-6.12	-5.91	-5.83	-5.81	-5.76	-5.76	-5.62

RANKED OUTPUT 3 16

ROLL	6.59	6.59	6.15	5.86	5.42	5.37	5.32	5.32
ROLL	-7.81	-6.20	-6.20	-5.62	-5.62	-5.47	-5.42	-5.37
ROLL	5.18	5.13	4.69	4.64	4.64	4.64	4.64	4.44
ROLL	-5.27	-5.27	-4.93	-4.88	-4.79	-4.79	-4.54	-4.20

RANKED OUTPUT 4 16

VBOWAC	2.21	2.18	1.94	1.89	1.82	1.66	1.58	1.50
VBOWAC	-1.30	-1.29	-1.20	-1.17	-1.17	-1.16	-1.14	-1.12
VBOWAC	1.45	1.42	1.42	1.40	1.38	1.32	1.30	1.25
VBOWAC	-1.09	-1.06	-1.06	-1.01	-1.01	-0.98	-0.98	-0.98

RANKED OUTPUT 5 16

VSTRNA	0.93	0.76	0.73	0.69	0.68	0.66	0.66	0.65
VSTRNA	-0.83	-0.76	-0.69	-0.63	-0.63	-0.59	-0.57	-0.56
VSTRNA	0.63	0.62	0.60	0.59	0.59	0.58	0.57	0.56
VSTRNA	-0.55	-0.55	-0.55	-0.52	-0.52	-0.52	-0.50	-0.50

RANKED OUTPUT 6 16

VCGAC	1.47	1.30	1.04	1.02	1.02	0.90	0.85	0.76
VCGAC	-0.69	-0.69	-0.63	-0.62	-0.58	-0.56	-0.55	-0.54
VCGAC	0.75	0.71	0.71	0.68	0.68	0.68	0.67	0.67
VCGAC	-0.51	-0.51	-0.50	-0.50	-0.49	-0.48	-0.47	-0.47

RANKED OUTPUT 7 16

TRCGAC	0.18	0.18	0.18	0.18	0.16	0.14	0.14	0.13
TRCGAC	-0.27	-0.25	-0.23	-0.21	-0.20	-0.19	-0.18	-0.18
TRCGAC	0.13	0.13	0.12	0.12	0.12	0.12	0.12	0.12
TRCGAC	-0.17	-0.17	-0.17	-0.17	-0.17	-0.17	-0.17	-0.17

MEAN VALUE NO. OF PEAKS RMS

WAVEHT	0.22	0	0.00
PITCH	0.24	94	2.80
ROLL	0.04	97	2.35
VBOWAC	0.03	399	0.40
VSTRNA	0.04	393	0.18
VCGAC	0.04	330	0.20
TRCGAC	-0.02	115	0.06
LWCGAC	-0.06	0	0.00

CHRONOLOGICAL OUTPUT 3 16

ROLL	5.32	1.86	1.03	4.39	2.93	5.37	0.39	1.95
ROLL	-6.20	-2.69	-1.12	-2.05	-3.91	-5.62	-2.98	-0.68
ROLL	3.66	3.76	1.76	3.08	5.13	4.69	4.64	4.25
ROLL	-2.20	-3.91	-1.76	-2.20	-3.52	-5.42	-4.15	-2.73

CHRONOLOGICAL OUTPUT 4 16

VBOWAC	0.44	1.82	0.98	0.33	0.34	0.13	0.08	0.23
VBOWAC	0.03	-1.17	-0.18	0.05	-0.08	-0.60	-0.13	-0.11
VBOWAC	0.05	0.36	0.90	0.21	0.26	0.44	0.55	0.36
VBOWAC	-0.28	-0.52	-0.21	-0.03	-0.88	-0.52	-0.03	-0.93

CHRONOLOGICAL OUTPUT 5 16

VSTRNA	0.34	0.31	0.39	0.13	0.26	0.50	0.53	0.18
VSTRNA	-0.09	-0.05	-0.44	-0.52	-0.37	-0.11	0.05	-0.11
VSTRNA	0.23	0.46	0.45	0.07	0.06	0.15	0.24	0.47
VSTRNA	-0.24	-0.20	-0.07	-0.29	-0.16	-0.19	-0.08	-0.11

CHRONOLOGICAL OUTPUT 6 16

VCGAC	0.76	0.42	0.36	0.23	0.17	0.06	0.28	0.19
VCGAC	-0.54	-0.32	0.08	-0.02	-0.06	-0.15	-0.39	-0.14
VCGAC	0.30	0.22	0.33	0.12	0.19	0.18	0.23	0.28
VCGAC	-0.61	0.02	-0.19	-0.41	-0.12	-0.07	-0.38	-0.34

CHRONOLOGICAL OUTPUT 7 16

TRCGAC	0.03	0.14	0.07	0.06	0.18	0.07	0.05	0.14
TRCGAC	-0.09	-0.27	-0.09	-0.07	-0.13	-0.09	-0.05	-0.14
TRCGAC	0.05	0.06	0.08	0.05	0.08	0.08	0.06	0.05
TRCGAC	-0.15	-0.09	-0.07	-0.17	-0.10	-0.08	-0.11	-0.17

SEAWORTHINESS TEST RESULTS IN SEA STATE 4 (13 MAR 1980)

RUN 12 S. BEAM SEA, SES, APPROX. 29 KNOTS

313S12

	CHRONOLOGICAL OUTPUT* 2 16				AVERAGE				AVE 1/3				EXTREME			
	PK	TR	FK	TR	PK	TR	FK	TR	PK	TR	FK	TR	PK	TR	FK	TR
FITCH	2.00	1.55	1.81	1.97	1.03	3.14	1.27	0.83	1.96	-1.34	3.77	-3.38	4.84	-5.18	6.02	-6.04
ROLL	-2.75	-2.38	0.46	-1.38	-1.14	-0.20	0.15	-1.06	3.77	-3.66	6.95	-6.82	9.27	-8.78	12.21	-9.42
PITCH	0.54	-2.78	-1.86	-0.16	-1.09	-0.20	1.61	2.49	0.31	-0.22	0.49	-0.41	0.65	-0.54	1.06	-0.72
VEGAC	-5.27	-5.53	-6.04	-3.58	-5.35	-1.35	0.05		0.25	-0.16	0.35	-0.26	0.45	-0.35	0.63	-0.51
TRCGAC	0.08	-0.12	0.15	-0.18	0.22	-0.22	0.41		0.27	-0.27	0.37	-0.27	0.46	-0.34	0.68	-0.42

	RANKED OUTPUT* 2 16							
FITCH	6.02	5.34	5.19	4.79	4.62	4.61	4.10	4.07
ROLL	-6.04	-6.02	-5.53	-5.35	-5.27	-4.80	-4.25	-4.13
PITCH	3.97	3.94	3.87	3.76	3.76	3.73	3.47	3.45
VEGAC	-3.76	-3.73	-3.69	-3.58	-3.14	-2.93	-2.86	-2.80

	RANKED OUTPUT* 3 16							
ROLL	12.21	10.74	9.96	8.89	8.59	8.15	7.81	7.76
VEGAC	-9.42	-9.33	-9.08	-8.98	-8.64	-8.45	-8.45	-7.86
PITCH	7.52	7.03	6.98	6.98	6.93	6.84	6.40	6.20
TRCGAC	-7.81	-7.37	-7.18	-6.98	-6.84	-6.79	-6.45	-6.35

	RANKED OUTPUT* 4 16							
VEGAC	1.06	0.94	0.86	0.86	0.83	0.75	0.72	0.72
ROLL	-0.72	-0.68	-0.67	-0.65	-0.65	-0.63	-0.62	-0.60
PITCH	0.68	0.68	0.67	0.67	0.63	0.63	0.63	0.63
TRCGAC	-0.59	-0.57	-0.55	-0.55	-0.54	-0.54	-0.54	-0.54

	RANKED OUTPUT* 5 16							
VEGAC	0.63	0.58	0.58	0.58	0.58	0.56	0.55	0.52
ROLL	-0.51	-0.46	-0.45	-0.44	-0.42	-0.42	-0.40	-0.38
PITCH	0.50	0.48	0.47	0.47	0.46	0.46	0.46	0.46
TRCGAC	-0.38	-0.37	-0.37	-0.37	-0.37	-0.36	-0.35	-0.34

	RANKED OUTPUT* 6 16							
VEGAC	0.68	0.57	0.53	0.51	0.50	0.50	0.48	0.48
ROLL	-0.42	-0.42	-0.42	-0.39	-0.39	-0.39	-0.38	-0.38
PITCH	0.48	0.47	0.46	0.46	0.45	0.44	0.44	0.42
TRCGAC	-0.37	-0.37	-0.35	-0.35	-0.35	-0.34	-0.33	-0.33

	RANKED OUTPUT* 7 16							
VEGAC	0.41	0.23	0.22	0.22	0.21	0.21	0.19	0.18
ROLL	-0.31	-0.26	-0.24	-0.21	-0.21	-0.20	-0.20	-0.19
PITCH	0.18	0.18	0.17	0.17	0.17	0.16	0.16	0.15
TRCGAC	-0.19	-0.19	-0.19	-0.18	-0.18	-0.18	-0.18	-0.18

	MEAN VALUE	NO. OF PEAKS	RMS
WAVEHT	0.25	0	0.00
FITCH	0.20	84	1.99
ROLL	0.03	86	3.49
VEGAC	0.03	399	0.21
PITCH	0.04	357	0.13
TRCGAC	0.05	298	0.14
TRCGAC	-0.02	116	0.07
TRCGAC	-0.05	0	0.00

SEAWORTHINESS TEST RESULTS IN SEA STATE 4 (13 MAR 1980)

313S14

RUN 14 P. QUARTERING SEA, SES, APPROX. 28 KNOTS

	AVERAGE			AVE 1/3			AVE 1/10			EXTREME		
	FK	TR	TR	FK	TR	TR	FK	TR	TR	FK	TR	TR
PITCH	1.49	-1.53	3.09	3.09	-3.23	4.06	-4.39	5.06	-5.71	5.06	-5.71	
ROLL	3.00	-3.11	5.78	5.78	-5.73	7.57	-7.66	9.47	-11.18	9.47	-11.18	
VRQWAC	0.25	-0.19	0.38	0.38	-0.33	0.50	-0.44	0.85	-0.81	0.85	-0.81	
USTRNA	0.24	-0.15	0.34	0.34	-0.25	0.45	-0.33	0.73	-0.54	0.73	-0.54	
VCGAC	0.25	-0.15	0.35	0.35	-0.24	0.45	-0.30	0.62	-0.40	0.62	-0.40	
TRCGAC	0.06	-0.12	0.13	0.13	-0.18	0.20	-0.22	0.27	-0.25	0.27	-0.25	

RANKED OUTPUT? 2 16

PITCH	5.06	4.44	3.86	3.84	3.84	3.84	3.84	3.56	3.40
	-5.71	-5.47	-4.07	-4.04	-4.00	-3.94	-3.94	-3.53	-3.37
FITCH	3.17	3.16	3.16	2.96	2.95	2.93	2.93	2.64	2.62
	-3.04	-3.01	-2.96	-2.96	-2.82	-2.78	-2.78	-2.78	-2.77

RANKED OUTPUT? 3 16

ROLL	9.47	9.42	8.25	7.62	7.37	7.08	6.88	6.74
	-11.18	-8.69	-8.25	-7.67	-7.62	-7.03	-6.69	-6.59
ROLL	6.45	6.45	6.35	6.20	6.10	5.76	5.71	5.57
	-6.45	-6.45	-6.30	-6.25	-6.10	-6.10	-6.05	-5.96

RANKED OUTPUT? 4 16

VRQWAC	0.85	0.67	0.67	0.63	0.55	0.54	0.54	0.52
	-0.81	-0.65	-0.52	-0.52	-0.50	-0.49	-0.49	-0.47
VRQWAC	0.50	0.50	0.50	0.49	0.47	0.46	0.46	0.46
	-0.47	-0.47	-0.46	-0.46	-0.44	-0.44	-0.42	-0.41

RANKED OUTPUT? 5 16

USTRNA	0.73	0.63	0.55	0.51	0.49	0.49	0.49	0.49
	-0.54	-0.49	-0.37	-0.37	-0.36	-0.36	-0.36	-0.35
USTRNA	0.46	0.46	0.46	0.44	0.44	0.42	0.42	0.40
	-0.34	-0.34	-0.32	-0.31	-0.31	-0.29	-0.29	-0.29

RANKED OUTPUT? 6 16

VCGAC	0.62	0.57	0.57	0.55	0.50	0.46	0.46	0.42
	-0.40	-0.37	-0.36	-0.34	-0.33	-0.31	-0.31	-0.30
VCGAC	0.42	0.42	0.42	0.42	0.41	0.40	0.38	0.37
	-0.30	-0.28	-0.28	-0.28	-0.28	-0.28	-0.27	-0.27

RANKED OUTPUT? 7 16

TRCGAC	0.27	0.25	0.23	0.22	0.20	0.18	0.18	0.16
	-0.25	-0.24	-0.22	-0.21	-0.21	-0.21	-0.21	-0.21
TRCGAC	0.16	0.15	0.15	0.14	0.13	0.13	0.12	0.11
	-0.21	-0.19	-0.19	-0.18	-0.18	-0.18	-0.18	-0.18

CHRONOLOGICAL OUTPUT? 2 16

PITCH	1.50	3.40	-0.24	-0.26	-1.32	-0.03	1.17	0.68
	-2.78	-4.04	-5.71	-2.64	-2.77	-4.07	-2.43	-0.18
FITCH	0.44	2.54	1.74	1.19	1.58	0.60	0.05	0.07
	-1.71	-1.90	-2.18	-0.65	-1.58	-1.19	-1.76	-1.94

CHRONOLOGICAL OUTPUT? 3 16

ROLL	2.39	1.95	3.12	0.10	-0.05	1.17	4.98	0.29
	-4.39	-4.44	-2.69	-3.22	-6.45	-2.64	-1.90	-4.20
ROLL	6.88	-0.29	-2.29	-2.05	6.74	2.05	9.42	6.35
	-5.13	-2.20	-3.66	-5.96	-6.30	0.24	-1.22	-0.63

CHRONOLOGICAL OUTPUT? 4 16

VRQWAC	0.33	0.18	0.67	0.18	0.24	0.39	0.18	0.42
	0.08	-0.13	-0.52	-0.10	-0.28	-0.23	-0.33	
VRQWAC	0.18	0.20	0.20	0.44	0.26	0.42	0.23	0.26
	-0.16	-0.15	-0.21	-0.15	-0.52	-0.37	0.00	-0.20

CHRONOLOGICAL OUTPUT? 5 16

USTRNA	0.33	0.32	0.18	0.19	0.12	0.22	0.27	0.15
	0.06	-0.07	-0.54	-0.20	-0.25	-0.15	-0.15	-0.14
USTRNA	0.29	0.14	0.44	0.19	0.18	0.16	0.11	0.19
	-0.12	-0.17	-0.12	-0.25	-0.12	-0.09	-0.15	-0.15

CHRONOLOGICAL OUTPUT? 6 16

VCGAC	0.32	0.26	0.36	0.34	0.21	0.62	0.24	0.25
	-0.30	-0.24	-0.16	-0.06	-0.12	-0.12	-0.28	-0.07
VCGAC	0.12	0.19	0.21	0.24	0.08	0.22	0.31	0.32
	-0.24	-0.16	-0.12	-0.15	-0.23	-0.20	-0.08	-0.15

CHRONOLOGICAL OUTPUT? 7 16

TRCGAC	0.11	0.06	0.06	0.05	0.09	0.01	-0.06	-0.02
	-0.07	-0.17	-0.21	-0.07	-0.09	-0.17	-0.18	-0.17
TRCGAC	-0.03	0.10	0.00	0.00	0.06	0.04	0.02	-0.04
	-0.16	-0.18	-0.17	-0.21	-0.11	-0.07	-0.09	-0.19

WAVEHT	MEAN VALUE	NO. OF PEAKS	RMS
PITCH	0.20	0	0.00
ROLL	-0.01	74	1.74
VRQWAC	-0.23	102	3.07
USTRNA	0.04	284	0.15
VCGAC	0.05	240	0.11
TRCGAC	-0.03	192	0.11
LMCGAC	-0.06	107	0.07
		0	0.00

SEAWORTHINESS TEST RESULTS IN SEA STATE 4 (13 MAR 1980)

313S15

RUN 15 P.BOW SEA, SES, APPROX. 27 KNOTS

	CHRONOLOGICAL OUTPUT?		2 16		AVERAGE		AVE 1/3		AVE 1/10		EXTREME	
	PK	TR	PK	TR	PK	TR	PK	TR	PK	TR	PK	TR
PITCH	2.60	5.96	4.80	3.30	4.48	4.22	7.41	7.37	6.82	6.71	6.71	7.62
ROLL	-1.48	-2.72	-6.27	-1.24	-1.86	-4.36	-4.64	-6.46	-6.36	-6.30	-6.30	-7.13
USTRNA	4.18	1.99	2.56	3.92	5.70	6.87	3.71	5.70	5.60	5.52	5.44	5.35
VEGAC	-6.36	-2.13	-1.74	-1.19	-4.35	-5.94	-4.64	-5.55	-5.53	-5.44	-5.27	-5.22

	RANKED OUTPUT?		2 16	
PITCH	7.62	7.41	7.37	6.87
ROLL	-7.13	-6.77	-6.49	-6.46
USTRNA	5.96	5.78	5.70	5.70
VEGAC	-5.83	-5.65	-5.65	-5.55

	RANKED OUTPUT?		3 16	
ROLL	6.98	6.84	6.64	6.59
USTRNA	-7.42	-7.08	-6.93	-6.54
VEGAC	6.15	5.96	5.96	5.71
TRCGAC	-5.71	-5.52	-5.47	-5.32

	RANKED OUTPUT?		4 16	
USTRNA	1.86	1.58	1.50	1.48
VEGAC	-1.20	-1.19	-1.16	-1.12
USTRNA	1.11	1.09	1.07	1.07
VEGAC	-1.03	-1.03	-0.99	-0.98

	RANKED OUTPUT?		5 16	
USTRNA	0.72	0.69	0.68	0.68
VEGAC	-0.71	-0.63	-0.59	-0.55
USTRNA	0.63	0.62	0.60	0.59
VEGAC	-0.50	-0.50	-0.48	-0.47

	RANKED OUTPUT?		6 16	
USTRNA	0.94	0.78	0.75	0.72
VEGAC	-0.59	-0.54	-0.53	-0.53
USTRNA	0.69	0.69	0.68	0.68
VEGAC	-0.50	-0.49	-0.49	-0.46

	RANKED OUTPUT?		7 16	
USTRNA	0.28	0.18	0.16	0.14
VEGAC	-0.24	-0.21	-0.20	-0.19
USTRNA	0.12	0.12	0.12	0.12
VEGAC	-0.17	-0.17	-0.17	-0.16

	RANKED OUTPUT?		8 16	
USTRNA	0.18	0.18	0.16	0.14
VEGAC	-0.18	-0.18	-0.18	-0.18
USTRNA	0.11	0.11	0.11	0.11
VEGAC	-0.16	-0.16	-0.16	-0.16

	RANKED OUTPUT?		9 16	
USTRNA	0.18	0.18	0.16	0.14
VEGAC	-0.18	-0.18	-0.18	-0.18
USTRNA	0.11	0.11	0.11	0.11
VEGAC	-0.16	-0.16	-0.16	-0.16

	RANKED OUTPUT?		10 16	
USTRNA	0.18	0.18	0.16	0.14
VEGAC	-0.18	-0.18	-0.18	-0.18
USTRNA	0.11	0.11	0.11	0.11
VEGAC	-0.16	-0.16	-0.16	-0.16

	RANKED OUTPUT?		11 16	
USTRNA	0.18	0.18	0.16	0.14
VEGAC	-0.18	-0.18	-0.18	-0.18
USTRNA	0.11	0.11	0.11	0.11
VEGAC	-0.16	-0.16	-0.16	-0.16

	RANKED OUTPUT?		12 16	
USTRNA	0.18	0.18	0.16	0.14
VEGAC	-0.18	-0.18	-0.18	-0.18
USTRNA	0.11	0.11	0.11	0.11
VEGAC	-0.16	-0.16	-0.16	-0.16

	RANKED OUTPUT?		13 16	
USTRNA	0.18	0.18	0.16	0.14
VEGAC	-0.18	-0.18	-0.18	-0.18
USTRNA	0.11	0.11	0.11	0.11
VEGAC	-0.16	-0.16	-0.16	-0.16

	RANKED OUTPUT?		14 16	
USTRNA	0.18	0.18	0.16	0.14
VEGAC	-0.18	-0.18	-0.18	-0.18
USTRNA	0.11	0.11	0.11	0.11
VEGAC	-0.16	-0.16	-0.16	-0.16

	RANKED OUTPUT?		15 16	
USTRNA	0.18	0.18	0.16	0.14
VEGAC	-0.18	-0.18	-0.18	-0.18
USTRNA	0.11	0.11	0.11	0.11
VEGAC	-0.16	-0.16	-0.16	-0.16

	RANKED OUTPUT?		16 16	
USTRNA	0.18	0.18	0.16	0.14
VEGAC	-0.18	-0.18	-0.18	-0.18
USTRNA	0.11	0.11	0.11	0.11
VEGAC	-0.16	-0.16	-0.16	-0.16

	RANKED OUTPUT?		17 16	
USTRNA	0.18	0.18	0.16	0.14
VEGAC	-0.18	-0.18	-0.18	-0.18
USTRNA	0.11	0.11	0.11	0.11
VEGAC	-0.16	-0.16	-0.16	-0.16

	RANKED OUTPUT?		18 16	
USTRNA	0.18	0.18	0.16	0.14
VEGAC	-0.18	-0.18	-0.18	-0.18
USTRNA	0.11	0.11	0.11	0.11
VEGAC	-0.16	-0.16	-0.16	-0.16

	RANKED OUTPUT?		19 16	
USTRNA	0.18	0.18	0.16	0.14
VEGAC	-0.18	-0.18	-0.18	-0.18
USTRNA	0.11	0.11	0.11	0.11
VEGAC	-0.16	-0.16	-0.16	-0.16

	RANKED OUTPUT?		20 16	
USTRNA	0.18	0.18	0.16	0.14
VEGAC	-0.18	-0.18	-0.18	-0.18
USTRNA	0.11	0.11	0.11	0.11
VEGAC	-0.16	-0.16	-0.16	-0.16

	RANKED OUTPUT?		21 16	
USTRNA	0.18	0.18	0.16	0.14
VEGAC	-0.18	-0.18	-0.18	-0.18
USTRNA	0.11	0.11	0.11	0.11
VEGAC	-0.16	-0.16	-0.16	-0.16

	RANKED OUTPUT?		22 16	
USTRNA	0.18	0.18	0.16	0.14
VEGAC	-0.18	-0.18	-0.18	-0.18
USTRNA	0.11	0.11	0.11	0.11
VEGAC	-0.16	-0.16	-0.16	-0.16

	RANKED OUTPUT?		23 16	
USTRNA	0.18	0.18	0.16	0.14
VEGAC	-0.18	-0.18	-0.18	-0.18
USTRNA	0.11	0.11	0.11	0.11
VEGAC	-0.16	-0.16	-0.16	-0.16

	RANKED OUTPUT?		24 16	
USTRNA	0.18	0.18	0.16	0.14
VEGAC	-0.18	-0.18	-0.18	-0.18
USTRNA	0.11	0.11	0.11	0.11
VEGAC	-0.16	-0.16	-0.16	-0.16

	RANKED OUTPUT?		25 16	
USTRNA	0.18	0.18	0.16	0.14
VEGAC	-0.18	-0.18	-0.18	-0.18
USTRNA	0.11	0.11	0.11	0.11
VEGAC	-0.16	-0.16	-0.16	-0.16

	RANKED OUTPUT?		26 16	
USTRNA	0.18	0.18	0.16	0.14
VEGAC	-0.18	-0.18	-0.18	-0.18
USTRNA	0.11	0.11	0.11	0.11
VEGAC	-0.16	-0.16	-0.16	-0.16

	RANKED OUTPUT?		27 16	
USTRNA	0.18	0.18	0.16	0.14
VEGAC	-0.18	-0.18	-0.18	-0.18
USTRNA	0.11	0.11	0.11	0.11
VEGAC	-0.16	-0.16	-0.16	-0.16

	RANKED OUTPUT?		28 16	
USTRNA	0.18	0.18	0.16	0.14
VEGAC	-0.18	-0.18	-0.18	-0.18
USTRNA	0.11	0.11	0.11	0.11
VEGAC	-0.16	-0.16	-0.16	-0.16

	RANKED OUTPUT?		29 16	
USTRNA	0.18	0.18	0.16	0.14
VEGAC	-0.18	-0.18	-0.18	-0.18
USTRNA	0.11	0.11	0.11	0.11
VEGAC	-0.16	-0.16	-0.16	-0.16

	RANKED OUTPUT?		30 16	
USTRNA	0.18	0.18	0.16	0.14
VEGAC	-0.18	-0.18	-0.18	-0.18
USTRNA	0.11	0.11	0.11	0.11
VEGAC	-0.16	-0.16	-0.16	-0.16

	RANKED OUTPUT?		31 16	
USTRNA	0.18	0.18	0.16	0.14
VEGAC	-0.18	-0.18	-0.18	-0.18
USTRNA	0.11	0.11	0.11	0.11
VEGAC	-0.16	-0.16	-0.16	-0.16

	RANKED OUTPUT?		32 16	
USTRNA	0.18	0.18	0.16	0.14
VEGAC	-0.18	-0.18	-0.18	-0.18
USTRNA	0.11	0.11	0.11	0.11
VEGAC	-0.16	-0.16	-0.16	-0.16

	RANKED OUTPUT?		33 16	
USTRNA	0.18	0.18	0.16	0.14
VEGAC	-0.18	-0.18	-0.18	-0.18
USTRNA	0.11	0.11	0.11	0.11
VEGAC	-0.16	-0.16	-0.16	-0.16

	RANKED OUTPUT?		34 16	
USTRNA	0.18	0.18	0.16	0.14
VEGAC	-0.18	-0.18	-0.18	-0.18
USTRNA	0.11	0.11	0.11	0.11
VEGAC	-0.16	-0.16	-0.16	-0.16

	RANKED OUTPUT?		35 16	
USTRNA	0.18	0.18	0.16	0.14
VEGAC	-0.18	-0.18	-0.18	-0.18
USTRNA	0.11	0.11	0.11	0.11
VEGAC	-0.16	-0.16	-0.16	-0.16

	RANKED OUTPUT?		36 16	
USTRNA	0.18	0.18	0.16	0.14
VEGAC	-0.18	-0.18	-0.18	-0.18
USTRNA	0.11	0.11	0.11	0.11
VEGAC	-0.16	-0.16	-0.16	-0.16

	RANKED OUTPUT?		37 16	
USTRNA	0.18	0.18	0.16	0.14
VEGAC	-0.18	-0.18	-0.18	-0.18
USTRNA	0.11	0.11	0.11	0.11
VEGAC	-0.16	-0.16	-0.16	-0.16

	R	
--	---	--



SEAWORTHINESS TEST RESULTS IN SEA STATE 4 (13 MAR 1980)

313S18

RUN 17 FOLLOWING SEA, SES, DIW, 0 KNOTS STERN TO SEA

	CHRONOLOGICAL OUTPUT 2 32				AVERAGE				AVE 1/3				AVE 1/10				EXTREME	
	PK	TR	PK	TR	PK	TR	PK	TR	PK	TR	PK	TR	PK	TR	PK	TR	PK	TR
PITCH	-0.05	2.10	3.53	-1.37	2.99	0.78	0.20	3.68	1.33	-4.31	3.15	-5.89	4.28	-7.01	4.87	-7.70	4.87	-7.70
ROLL	-4.25	-3.45	-6.88	-2.83	-4.33	-4.36	-2.96	-6.58	2.72	-2.76	4.37	-4.45	5.68	-5.60	6.45	-6.45	6.45	-6.45
VBOWMAC	0.14	0.14	0.21	-0.12	0.20	-0.14	0.25	-0.33	0.13	-0.05	0.20	-0.14	0.25	-0.19	0.36	-0.33	0.36	-0.33
VSTRNA	0.11	0.11	0.15	-0.03	0.15	-0.02	0.10	-0.36	0.11	-0.03	0.15	-0.06	0.17	-0.08	0.21	-0.10	0.21	-0.10
VCGAC	0.11	0.11	0.15	-0.03	0.15	-0.02	0.10	-0.36	0.11	-0.03	0.15	-0.06	0.17	-0.08	0.21	-0.10	0.21	-0.10
TRCGAC	0.05	0.05	0.06	-0.11	0.06	-0.14	0.08	-0.20	0.05	-0.11	0.06	-0.14	0.08	-0.16	0.08	-0.20	0.08	-0.20

	RANKED OUTPUT? 2 32			
PITCH	4.87	4.52	4.17	4.15
ROLL	-7.70	-7.23	-6.88	-6.64
VBOWMAC	2.99	2.95	2.93	2.88
VSTRNA	-5.68	-5.58	-5.57	-5.50
VCGAC	-5.68	-5.58	-5.57	-5.45
TRCGAC	-5.68	-5.58	-5.57	-5.42

	RANKED OUTPUT? 3 32			
PITCH	6.45	6.30	5.76	5.76
ROLL	-6.45	-6.15	-6.10	-5.32
VBOWMAC	4.88	4.54	4.30	4.30
VSTRNA	-4.83	-4.79	-4.59	-4.35
VCGAC	-4.83	-4.79	-4.59	-4.10
TRCGAC	-4.83	-4.79	-4.59	-4.10

	RANKED OUTPUT? 4 32			
PITCH	0.42	0.36	0.33	0.31
ROLL	-0.26	-0.24	-0.23	-0.21
VBOWMAC	0.28	0.28	0.26	0.26
VSTRNA	-0.20	-0.20	-0.18	-0.18
VCGAC	-0.20	-0.20	-0.18	-0.16
TRCGAC	-0.20	-0.20	-0.18	-0.16

	RANKED OUTPUT? 5 32			
PITCH	0.30	0.31	0.30	0.29
ROLL	-0.33	-0.31	-0.27	-0.24
VBOWMAC	0.27	0.27	0.27	0.27
VSTRNA	-0.20	-0.20	-0.20	-0.19
VCGAC	-0.20	-0.20	-0.19	-0.19
TRCGAC	-0.20	-0.20	-0.19	-0.19

	RANKED OUTPUT? 6 32			
PITCH	0.21	0.20	0.19	0.19
ROLL	-0.10	-0.09	-0.09	-0.08
VBOWMAC	0.15	0.15	0.15	0.15
VSTRNA	-0.08	-0.08	-0.07	-0.07
VCGAC	-0.08	-0.08	-0.07	-0.07
TRCGAC	-0.08	-0.08	-0.07	-0.07

	RANKED OUTPUT? 7 32			
PITCH	0.08	0.08	0.08	0.07
ROLL	-0.20	-0.16	-0.15	-0.14
VBOWMAC	0.06	0.06	0.06	0.06
VSTRNA	-0.13	-0.13	-0.13	-0.12
VCGAC	-0.13	-0.13	-0.13	-0.12
TRCGAC	-0.13	-0.13	-0.13	-0.12

	MEAN VALUE	NO. OF PEAKS	RMS
HAVENT	0.11	0	0.00
PITCH	-1.55	55	2.17
ROLL	0.03	77	2.25
VBOWMAC	0.03	319	0.08
VSTRNA	0.04	399	0.08
VCGAC	0.05	139	0.04
TRCGAC	-0.03	51	0.04
LNCGAC	-0.04	0	0.00

APPENDIX B  
RELIABILITY, MAINTAINABILITY AND MAINTENANCE

## APPENDIX B

### Reliability, Maintainability and Maintenance

B-1. General. This appendix reports the measured and observed reliability, maintainability, availability and required maintenance during the Surface Effect Ship's test period. Prior to the test period the SES had accumulated approximately 712 hours of operation. During the test period the SES operated 116 hours.

B-2. Procedure. Prior to the start of the evaluation, discussions were held with the crew to ascertain the condition of the machinery plant and all other operating systems onboard the craft including hull integrity. Equipment failure and maintenance problems experienced prior to the test were discussed with the Captain and Engineer in general terms since no official records were available. These discussions indicated that the highest failure item has been the raw water pump impellers and strut and hull cracks in the after structure. Design changes in the after hull structure were made to eliminate this problem, i.e., relocate fuel tanks to the lazarette and make them non-integral in lieu of integral. The total down time and effect on experienced and potential operation is unknown to this activity.

During the entire evaluation period all operation and maintenance data was collected on a daily basis and an assessment was made of the effect that any failure or degraded performance had on the ability to get underway for the daily test procedure or to achieve a mission related requirement. During the test period one critical failure and four major failures occurred. A critical failure is defined as one which results in the ship's inability to get underway or perform to full design potential. A major failure is one which causes a significant reduction in the capability of the ship.

### B-3. Design Considerations

B-3.1 Design. The hull construction techniques are typical of gulf coast constructed crew boats, i.e., a combination of continuous and intermittent welding at random spacing. Many of the observed intermittent welds have developed hairline cracks at craters at weld terminations. The welds crater cracks were observed throughout the craft where intermittent welding was used.

B-3.2. Machinery. The propulsion and lift fan engines are conventional diesel and can be found in both military and crew boats around the world. Detroit Diesel engines, of the types installed, have accumulated thousands of operating hours in various marine environments. Other support systems are common in military and crew boats and represent production standards in design and fabrication. The exception to military standard is the use of black iron pipe in the piping systems of the SES.

B-4. Failure and Maintenance Data. During the test period all failure and maintenance data were collected. In addition the crew was interviewed each morning prior to underway operations to determine what preventive maintenance had been performed as a result of the prior day's operations. All preventive maintenance was of a routine nature with no unusual maintenance requirements. Failure data is shown in figure B-1. The only item not shown is the

development of a hull crack in the port underwater hull. This crack leaked constantly and was patched by a diver with a temporary patch. The leak did not endanger the crew or craft and was contained within the after port rudder compartment. The stern seal developed a split which was first observed to be approximately 6 inches long. This split had grown to several feet in length at the completion of the test. The hull crack was not observed by the test activity and the split in the skirt was not actually measured.

B-5. Reliability and Maintainability. As a result of the short test period and a limited data base, statistical projections have not been conducted to predict the overall reliability and maintainability of the SES. It would be more appropriate, however, to provide an objective overview of the SES as compared to other craft that have undergone extensive test and evaluation programs. The SES performed as well as any other craft that has been tested and the failure rate of equipment is much lower than previously tested craft; however, this craft has had a year shakedown prior to this test and has been in actual operation as a crew boat. Therefore, the failure rate should be much lower than a prototype boat or craft. The SES is considered, based on the test period, to be maintainable and reliable. It is recommended, however, that the hull structure undergo a design review prior to any procurement action by the U.S. Government.

B-6. Simulated Ferry Operation. The SES was made available for VIP use on 28 February 1980. During that underway exercise a simulated ferry operation was undertaken. Figure B-2 depicts a block time chart of that exercise.

FIGURE B-1

EQUIP	FAILURE	DATA	CRITICAL	MAJOR	MTTR HRS
RAW WATER PUMP IMPELLER- GENERATOR	RAW WATER PUMP IMPELLER FAILED. REPLACED WITH ONBOARD SPARE.	2/25/80		X	.3
RAW WATER PUMP IMPELLER- GENERATOR	RAW WATER PUMP IMPELLER FAILED. REPLACED WITH ONBOARD SPARE.	2/27/80		X	.3
GASKET-TURBO CHARGER STBD	TURBO-CHARGER GASKET LEAKING AIR. REPLACED WITH ONBOARD SPARE.	2/28/80		X	1.0
TURBO CHARGER, STBD ENGINE	EMERGENCY SHUT- DOWN MECHANISM SHAFT FAILED ALLOWING THE FLAPPER VALVE ON AIR INTAKE PASSAGE FROM THE BLOWER TO GO TO THE CLOSED POSITION WHEN TURBO CHARGER CAME ON LINE,  SHUT FLAPPER CAUSED TURBO STALL AND OVER- HEAT	3/1/80	X		2.0 <sup>1</sup>
FLAPPER VALVE, BLOWER, STBD	SEE ABOVE	3/2/80		X	1.0

<sup>1</sup> DOWN TIME - 24 HRS AWAITING PART AND MECHANIC. TURBO CHARGER WAS REPLACED AND FLAPPER REMOVED. SHAFT LEFT IN FAILED CONDITION FOR LATER REPLACEMENT; EST TIME 1.0 MTTR HRS.

FIGURE B-2

TIME SPEED	0900 0	0901 0	0910 0	0915 0-10	0920 10-31	1011 31	1011-1103 5-25	1104 31	1155 10-31	1200 10	1205 0	1215 0
	COLD PLANT, CREW ALERTED TO PREPARE TO DEPART											
	ALERT PASSENGERS											
	ENGINES READY, LINES OFF											
	UNDERWAY TO CLEAR HARBOR											
	CLEAR LITTLE CREEK HARBOR											
	ARRIVE CHESAPEAKE LIGHT											
	OPS CHESAPEAKE LIGHT											
	DEPART CHESAPEAKE LIGHT											
	ARRIVE LITTLE CREEK HARBO											
	ENTER LITTLE CREEK HARBOR											
	DOCKED AT PIER											
	SHUTDOWN											

\* OPS IN UNRESTRICTED WATERS, 52.5 N.M. WERE COVERED AT AN AVERAGE SPEED OF 30.9 KNOTS. SEA AND WINDS WERE LOW TO CALM.

APPENDIX C

VESSEL MANNING STANDARDS AND HUMAN FACTORS CONSIDERATIONS

## APPENDIX C<sup>1</sup>

### Vessel Manning Standards and Human Factors Considerations

#### C-I. PURPOSE AND SCOPE

A. The purpose of this section is to develop and document preliminary quantitative manning estimates and to present findings on a brief human engineering design survey for use by the interested activities in projecting operational manpower estimates for their respective uses of the craft. Qualitative manning requirements have also been projected to the extent possible, where appropriate.

B. The scope of the following report in regard to both manning requirement determinations and human engineering efforts will be limited to areas concerning basic craft operation and maintainability while in operation. It will exclude considerations of potential weapon systems and shore based maintenance support personnel.

#### C-II. APPROACH/METHODOLOGY

A. Data gathering for use in the development of this section included the following:

1. An initial visit to NAVSEADDET, Norfolk, for briefing on the SES Test Program and initial planning in regard to testing purpose, scope and protocol.

2. Familiarization with the SES through the examination of manufacturer supplied reports, technical and engineering drawings and documents on development, performance and intended uses.

3. An initial familiarization visit to the SES at the Bell-Halter industrial facility at New Orleans, LA, while the craft was out of the water for inspection and repair.

4. Observations and data gathering while the craft was in operation during the test period at the Naval Amphibious Base, Little Creek (Norfolk), VA. Included were observations of pilot house and engineering spaced activities while underway. The following evolutions were observed:

a. Getting underway

b. High speed maneuvering

c. Low speed maneuvering

d. Personnel transfer via hoist from the boat to a stationary facility at sea (basket hoist to Chesapeake Light Tower)

e. Open water operation of the craft by inexperienced personnel at maximum cruising speed

f. Docking and securing

5. Discussions with the Bell-Halter crew and with pertinent test personnel.

6. Review of U.S. Coast Guard (Federal) regulations pertaining to operation of small passenger vessels.

7. Discussion with U.S. Coast Guard personnel familiar with the operation and manning of the 95-foot patrol boat (WPP).

B. Analysis of data assembled and development of preliminary manning estimates included the following assumptive parameters:

<sup>1</sup> Prepared by: Personnel and Training Analysis Office (NAVSEA05LIC), Washington Navy Yard, Washington, D.C.

1. The projected USCG patrol boat and commercial ferry craft would utilize the same basic hull size/design and propulsion systems as currently configured, (Bell-Halter Hull #1). It is recognized that utilization of the Bell-Halter SES as an LCM-9 type craft would require drastic reconfiguration such as installation of bow or stern ramp, resituation of pilot house, etc.

2. The projected operational environment and mission of the SES utilized as a USCG patrol boat would be the same as that of the 95-foot WPB.

3. Manning recommendations for the craft uses addressed would only include craft operations. Corrective Maintenance (CM), Planned Maintenance (PM), and Facilities Maintenance (FM) analyses would not be conducted as insufficient data exists to adequately project workload estimates in these areas.

4. The commercial ferry version will be assumed to remain under 100 gross tons and remain within the provisions of the Code of Federal Regulations (CFR), title 46, subchapter T. No weight limitation will apply for a military configuration of the craft.

5. The commercial ferry version would operate within protected or partially protected waters as defined in the CFR, title 46, subpart 178.05, and the duty day for craft operation personnel would be less than 12 hours.

### C-III. MANNING ANALYSIS

#### A. Commercial Passenger Ferry Craft

1. Discussion: The Bell-Halter SES, configured for the conveyance of approximately 275 passengers on a frequent, scheduled basis would be designated as an "L" vessel<sup>2</sup> under U.S. Coast Guard regulations for small passenger vessels. Upon USCG inspection of the craft, prior to it being placed into service, the Officer in Charge, Marine Inspection, will certificate the craft in accordance with "L" vessel requirements for the appropriate minimum qualitative and quantitative composition of the crew. Establishing the minimum crew composition is a judgemental determination based upon many factors, including, but not limited to, projected operating scenario, number of passenger spaces and ingress/egress routes, particularly in regard to emergency egress, and other considerations primarily involved with proper navigation and operation of the vessel and necessary protection of the vessel and passengers during emergencies.

At the time of testing, within an anticipated ferry operating scenario, the SES is certificated for the conveyance of 57 passengers with a crew consisting of one ocean operator and two deck hands for one "watch", or a duty day of 12 hours or less. During a duty day two operators would be primarily involved with operation/navigation duties in the pilot house. The deck hands fulfill two functions: general engineering/boatswain duties; and duties involved with seeing to the safety/survival needs of the passengers in emergency situations. As the number of passengers increases, it must be assumed that the required number of deck hands or attendants will increase, as determined by the inspecting officer, although not necessarily at the same arithmetical rate.

Passenger seating is centrally located aboard the craft in a dedicated space and passengers are requested to remain seated during transit periods, except for use of the restroom, etc. No passengers are permitted below decks or outside of the passenger cabin during operation. This concept would best

<sup>2</sup> In general: > 65 ft in length, < 100 gross tons, and carries passengers for hire

be adopted for commercial ferry operation as it confines the passengers to a space where they cannot only enjoy maximum comfort and safety while underway, but they would also be able to more readily receive instructions and assistance in any emergency situation.

2. Findings: The Bell-Halter SES has been operating for over a year, involved with the conveyance of "passengers" in its crew boat utilization. As far as minimal "operational" manning requirements are concerned, the in-service record of the SES has confirmed that a crew of three personnel, in quantitative terms, can adequately handle the conveyance of up to 50 passengers. In actual practice, one of the two "deck hands" functions primarily as an engineering watch stander while the craft is underway insuring proper functioning of the propulsion, lift and auxiliary systems.

In passenger ferry usage, with increased ship power production, passenger support systems and other auxiliary systems requirements, one crew position should be dedicated to an engineering spaces watch. This assignment would bring the operational crew minimum to four, prior to the consideration of additive manning to directly support 225 additional passengers. Table III-1 outlines the operational manning projections for a commercial ferry version of the SES.

Beyond basic operational requirements, the addition of 225 passengers, by extending the passenger cabin aft for added seating space and restrooms, etc., will obviously necessitate additive attendant manning. The total number required would have to be a best estimate at this point, based on an individual viewpoint, because of undefined factors such as duration of passage, ingress/egress design, state or local requirements, union agreements, if applicable, concessions anticipated, ticket/pass taking methods, etc. However, the primary factor driving attendant manning will be the assurance of the minimum number of personnel required to see to the safety, rescue and survival of the passengers in all emergency situations. Using safety as a baseline for the purpose of making a projection, and assuming that additional 25-man inflatable life rafts (2 currently aboard) would be required to support 30-50% of the maximum passenger capacity, an estimated 2 to 3 additional crew members would be necessary. Each deck hand and attendant would be responsible for deployment of a raft and seeing to its orderly occupancy.

#### B. U.S. Coast Guard Patrol Boat Operational Requirements

1. Discussion: At present, the 95-foot WPB performs its assigned mission requirements with a crew of 154. Current standard composition of the WPB crew is as follows:

##### Current U.S. Coast Guard 95-Foot WPB Manning

- Commanding Officer
- Quartermaster
- Boatswain's Mates (2)
- Machinery Technicians (4)
- Electrician's Mate
- Seamen (4)
- Ship's Cook

Basic craft operations while underway are performed with three watchstanders rotating 8 hours during a 24-hour duty day (4 hours on - 8 hours off). The watch positions consist of an Officer of the Deck (OOD), a Helmsman, and an Engineering Watch, requiring an operational total of 9 personnel. The additional quantitative manning is required for the performance of special evolutions involved with the WPB mission, such as law enforcement, boarding, rescue operations, etc. The cook is primarily for crew support and his duties

TABLE III - 1

PASSENGER FERRY PROJECTED OPERATIONAL MANNING

<u>POSITION(S)</u>	<u>QUALIFICATION</u>	<u>PRIMARY DUTIES</u>	<u>SECONDARY/COLLATERAL DUTIES</u>
1. Operator/ Boat Captain	Licensed Operator	<ol style="list-style-type: none"> <li>1. Boat Navigation and Control</li> <li>2. Supervision of Crew</li> <li>3. Directs Emergency Operations</li> </ol>	<ol style="list-style-type: none"> <li>1. Oversees Special Evolutions, (Fueling, Inspection, Etc.)</li> <li>2. Insures Completion of Required Logs, Records, etc.</li> </ol>
2. Engineer	Marine Engineman, or Diesel Engine Mechanic with Marine Engineering Experience	<ol style="list-style-type: none"> <li>1. Operates and Maintains Power Plants</li> <li>2. Operates and Maintains Auxiliary Systems</li> <li>3. Performs Emergency Corrective Procedures, as necessary</li> <li>4. Insures Proper Operation and Application, if necessary, of Fire Fighting Equipment/Systems</li> </ol>	<ol style="list-style-type: none"> <li>1. Directs Resupply, Fueling, Potable Water Protection, etc.</li> <li>2. Maintains Engineering Records as required</li> </ol>
3. Deck Hand	Mate or Able Seaman	<ol style="list-style-type: none"> <li>1. Handling and Storage of Mooring Lines, Anchoring Gear, etc.</li> <li>2. Underway Lookout</li> </ol>	<ol style="list-style-type: none"> <li>1. Passenger Control and Safety</li> <li>2. Assists Boat Captain or Engineer, as necessary</li> </ol>
4. Deck Hand	Mate or Able Seaman (may be an apprentice)	<ol style="list-style-type: none"> <li>1. Handling and Storage of Mooring Lines, Anchoring Gear, etc.</li> </ol>	<ol style="list-style-type: none"> <li>1. Passenger Control and Safety</li> <li>2. Assists While Underway as Directed</li> </ol>
5. Attendants/ Deckhands (2-3)	Apprentice Seamen	<ol style="list-style-type: none"> <li>1. Passenger Safety and Control</li> </ol>	<ol style="list-style-type: none"> <li>1. Deck Assistance as necessary</li> </ol>

NOTE: All operational crew members and attendants should be certified lifeboatmen and be thoroughly proficient in the use of all shipboard firefighting equipment and lifesaving equipment.

are obvious. The qualitative composition of the WPB particularly in the engineering area is driven not only by required maintenance capability while underway, but also by preventive and corrective maintenance requirements while in port - areas not addressed in this report.

2. Findings:

a. Based on observations of SES underway operation, the estimated crew requirements for its use as a replacement for the 95-foot WPB are well within the capability of the currently authorized crew. Although the SES is a product of both innovative design and "state-of-the-art technology," its operation with conventional skills, particularly those found aboard the WPB, will only require minimal training and orientation. The helm of the craft employs conventional or near conventional controls and its engineering spaces employ conventional power plants (the SES propulsion engines are the same as those utilized in the WPB).

b. Table III-2 contains recommended manning to perform craft operations of the SES as configured for WPB usage. Included is manning necessary for three, three-section watches. Also included is a Commanding Officer as this position is considered necessary for crew supervision/management and making executive decisions on mission responsibilities and special evolutions, as necessary. Rationale for the estimated rating mix is included in the primary responsibilities of each billet within Table III-2. It should be pointed out that alterations in the skill mix may be necessary if significantly different equipment is installed due to changing operational or mission requirements.

c. Training and orientation for operation of the SES by an experienced WPB crew will largely be involved with familiarization with the pilot house controls, (particularly the lift system controls), and engineering orientation training on lift engines and fan maintenance.

C. Use of SES by the U.S. Navy as a Landing Craft (LCM-9)

1. Discussion: The U.S. Navy is interested in a relatively fast landing craft as a replacement for the LCM-8, to support amphibious assault operations in the 1980's and 1990's. The role of the LCM-9 will be that of a minimally manned craft capable of delivering a heavy payload in heavy sea and surf conditions. The LCM-9 will be required to perform several varied Fleet support roles, such as:

- a. Conduct towing/salvage/rescue operations
- b. Provide sealift for cargo and personnel
- c. Conduct search and rescue operations
- d. Provide Fleet training services
- e. Provide disaster assistance including evacuation and transportation of casualties
- f. Serve as a platform for diving operations

The LCM-9 will be required to operate in normal marine environment for ships and craft. In addition, the craft must be capable of maneuvering into and out of well decks of amphibious ships, as well as transiting a surf zone to load/unload troops and cargo. The ability to maneuver in a well deck requires that engine exhaust gases be minimized to prevent harmful concentrations, and that the structure be rugged or sufficiently protected in order to withstand hull damage from contact with well deck sides. The craft will also be capable of approaching the beach sufficiently close so that troops/cargo can be safely offloaded.

TABLE III - 2

ESTIMATED OPERATIONAL REQUIREMENTS FOR SES WPB

<u>BILLET CLASSIFICATION</u>	<u>WATCH STATION/POSITION</u>	<u>PRIMARY RESPONSIBILITIES</u>
1. Commissioned Officer	Commanding Officer	Executive Decisions Involving Ship Operation and Control, Special Evolutions; Protocol Duties, as required
2. Quartermaster	Officer of the Deck*	OOD Watchstander - Provides Functional Expertise on Ship Operation and Control
3. Boatswain's Mate		OOD Watchstander - Provides functional Expertise on Deck Operations in Getting Underway, Mooring/Anchoring and Special Evolutions
4. Boatswain's Mate		
5. Seaman	Helmsman*	Helmsman Watchstander - Ship Control/ Navigation as Directed by OOD
6. Seaman		
7. Seaman		
8. Machinery Technician	Engineering Officer*	EOW Watchstander - Provides Functional Expertise on Machinery Operation and Necessary Underway Maintenance
9. Machinery Technician		
10. Electricians Mate		EOW Watchstander - Provides Functional Expertise on Ship Power Production and Other Electrical Operations and Maintenance Requirements

\*Three-Section Watch Stations; Requiring Three Billets each

Manning of the craft will be kept to the minimum required to operate the craft. In executing its wartime mission, the crew members should be trained to act as a homogeneous unit with each member able to assume other crew member's duties in a casualty situation. Because of this concept it would be difficult to segregate purely operational duties from those involving defense, communication, etc. Therefore, the recommended operational crew will show a complete, estimated manning complement.

2. Recommendation: Based upon a minimum manning concept with the ability to accomplish its assigned mission, LCM-9 (SES) estimated manning is contained in Table III-3.

#### C-IV. HUMAN ENGINEERING SURVEY OF THE BELL-HALTER 110-FOOT SES

A. A brief survey was made of the Bell-Halter 110-foot SES while the craft was underway conducting a Coast Guard demonstration run. The major objective of the survey was to examine the current craft design in order to provide recommendations for the human engineering design effort which would be required if the craft were reconfigured as a commercial passenger craft or as a Coast Guard patrol boat.

B. The following comments resulted from the human engineering survey of the Bell-Halter 110 foot SES.

1. The controls and instruments in the pilothouse should be rearranged for more effective operation. At present they are generally too spread out and not logically organized. For example, the lift control and the engine controls are located on opposite sides of the wheel such that when the operator is adjusting lift and propulsion at the same time, the wheel is not under control. Consideration should also be given to increasing the angle of the instrument panel.

2. The lift and propulsion engine tachometers are located appropriately with respect to the operator's primary visual field, but they are arranged in a pattern different from the pattern of the controls.

3. Switching main engine control is done by depressing a control at the station where propulsion control is wanted. The control, unfortunately, is the size, shape, and located such that it can easily be accidentally depressed, resulting in the loss of control at the station where it is expected. This control should be guarded to require more positive action.

4. Visibility from the pilothouse is generally excellent during daylight hours. At night, some interior indicators are too bright for good dark adaption and some cast glare on the windows.

5. More upward visibility from the pilothouse aft steering station would be desirable for the craft in its present mission and should be considered in potential missions.

6. Markings on hatches to show the OPEN or LOCK position of handles would be desirable.

7. A ladder up to the escape hatch from the engineroom would be desirable. The escape hatch in the aft-most compartment is now partially blocked by a recently installed fuel tank. A big man would need considerable adrenalin to get out of this hatch very rapidly.

8. Cables and pipes throughout craft need marking for identification, i.e., system, circuit, voltage, pneumatic hydraulic, pressure level, fuel, lube, direction of flow, etc.

TABLE III - 3

U.S. NAVY LCM-9 (SES) OPERATIONAL MANNING ESTIMATES

<u>STATION</u>	<u>RATING</u>	<u>PRIMARY RESPONSIBILITIES</u>
Coxswain	Boatswain's Mate	Craft Operation and Control
Engineer	Engineman (Diesel)	Propulsion and Other Engineering Operation and Underway Maintenance
Communications	Radioman (or Operations Specialist of Radar(s) installed)	Intra- and Inter-craft Communications, Assistant to Coxswain on Operational Orders Received
Gunner	Gunner's Mate	Offensive/Defensive Fire Control
Deck Seamen (2)	Boatswain's Mate SN	General Deck Duties, Operation of Doors, Ramps, Lifts, unique equipment for special evolutions, etc.

9. At present, the engineer must rove the engine compartment to check gauges and instruments and must compare readings from instruments in several locations. In addition, to check a cooling pump temperature, for example, he must crawl out on to the engines and check the temperature with his hand. This involves a certain amount of risk. Recommend that sensors be installed to measure required engine and electrical functions and that this information be brought together into a central, integrated engineering panel, with engineroom circuit breakers and bridge communications.

10. While two separate radar systems are desirable from a redundancy/reliability point of view, consideration should be given to relocating one CRT to the navigator's area.

11. There was no built-in fire protection or fire suppression system seen in the craft.

12. Walking around inside the craft, while underway, is a little tricky in spacious compartments, at least for lubbers. The craft should be provided with installed hand grabs or rails so that passengers or crewmen can move around as necessary.

The human engineering considerations identified above are merely examples of some of the problems which appeared in a brief survey of this craft. If designed as a Coast Guard patrol boat, additional study areas would need to be considered, both in regard to militarizing the craft and to the installation and manning of mission equipment. Still other areas would need to be examined were the craft to be configured as a commercial passenger craft.

There are a number of human engineering standards used to guide the design of military hardware which are equally applicable to civil hardware since the standards are oriented to function, mission, and environment. These standards include MIL-STD-1472B, "Human Engineering Design Criteria for Military Systems, Equipment and Facilities"; MIL-STD-759, "Human Factors Engineering Design for Army Material"; and, Air Force Systems Command Design Handbook, DH 1-3, "Human Factors Engineering".

It is critical that the human engineering effort begin in the very early stages of a system design program. Professional human engineering effort in a program appropriately starts during the preparation of the contract and proceeds throughout design and tests and trials. Human engineering technology serves little purpose after the craft design is frozen, except to document mistakes.