

AD-A096 526

NAVAL OCEAN SYSTEMS CENTER SAN DIEGO CA
CONTROL SCHEME FOR THE MICROPROCESSOR CONTROLLED LIFT MODULE.(U)
FEB 81 R W BUECHER
NOSC/TR-653

F/G 13/10

UNCLASSIFIED

NL

1 of 1
NO 2
005-026

NOSC



END
DATE
FILMED
4-81
DTIC

LEVEL II

12

NOSC

NOSC TR 653

NOSC TR 653

AD A 096526

Technical Report 653

CONTROL SCHEME FOR THE MICROPROCESSOR CONTROLLED LIFT MODULE

Roger W. Buecher

February 1981

Final Report: 1980

Prepared for
Naval Sea Systems Command

DTIC
ELECTE
MAR 19 1981
S D

A

Approved for public release; distribution unlimited

NAVAL OCEAN SYSTEMS CENTER
SAN DIEGO, CALIFORNIA 92152

81 3 18 030

DBS FILE COPY



NAVAL OCEAN SYSTEMS CENTER, SAN DIEGO, CA 92152

A N A C T I V I T Y O F T H E N A V A L M A T E R I A L C O M M A N D

SL GUILLE, CAPT, USN
Commander

HL BLOOD
Technical Director

ADMINISTRATIVE INFORMATION

The author thanks C. G. Lenz and R. T. Hoffman, both of NOSC Code 5332, for their assistance in the technical review of this document. This work was funded by the Civil Engineering Laboratory's "Construction Diver Lift Systems" program.

Released by
JK KATAYAMA, Head
Ocean Systems Division

Under authority of
JD HIGHTOWER, Head
Environmental Sciences Department

10, Roger W. / Buecher

UNCLASSIFIED

SECURITY CLASSIFICATION OF THIS PAGE (When Data Entered)

REPORT DOCUMENTATION PAGE		READ INSTRUCTIONS BEFORE COMPLETING FORM
1. REPORT NUMBER NOSC Technical Report 653	2. GOVT ACCESSION NO. AD-A096	3. RECIPIENT'S CATALOG NUMBER 526
6) 4. TITLE (and Subtitle) CONTROL SCHEME FOR THE MICROPROCESSOR CONTROLLED LIFT MODULE.	5. TYPE OF REPORT & PERIOD COVERED Final FY 80	
	6. PERFORMING ORG. REPORT NUMBER	
7. AUTHOR(s) RW BUECHER	9) Final rept	8. CONTRACT OR GRANT NUMBER(s) 16) 50397
9. PERFORMING ORGANIZATION NAME AND ADDRESS Naval Ocean Systems Center, Hawaii Laboratory P. O. Box 997 Kailua, Hawaii 96734	13) 93 17	10. PROGRAM ELEMENT, PROJECT, TASK AREA & WORK UNIT NUMBERS 63713N: S0397SL; 521-MT32
11. CONTROLLING OFFICE NAME AND ADDRESS Naval Sea Systems Command, Code 05R2 Department of the Navy Washington, D. C. 20360	11)	12. REPORT DATE February 1981
		13. NUMBER OF PAGES 22
14. MONITORING AGENCY NAME & ADDRESS (if different from Controlling Office) 14) NOSC/TR-653	15. SECURITY CLASS. (of this report) Unclassified	
	15a. DECLASSIFICATION/DOWNGRADING SCHEDULE	
16. DISTRIBUTION STATEMENT (of this Report) Approved for public release; distribution unlimited.		
17. DISTRIBUTION STATEMENT (of the abstract entered in Block 20, if different from Report)		
18. SUPPLEMENTARY NOTES		
19. KEY WORDS (Continue on reverse side if necessary and identify by block number) Ascent Midwater hovering Descent Diver Lift Module Microprocessor		
20. ABSTRACT (Continue on reverse side if necessary and identify by block number) An experimental, totally self-contained lift module has been demonstrated which was controlled by a microprocessor in preprogrammed or diver selected modes of operation. These included ascent or descent at specific speeds and mid-water hovering. The output of the computer simulation which was used to develop the control logic for the micro-processor agreed favorably with the test results.		

DD FORM 1 JAN 73 1473

EDITION OF 1 NOV 65 IS OBSOLETE
S/N 0102-014-66011

UNCLASSIFIED

393159

SECURITY CLASSIFICATION OF THIS PAGE (When Data Entered)

UNCLASSIFIED

SECURITY CLASSIFICATION OF THIS PAGE(When Data Entered)

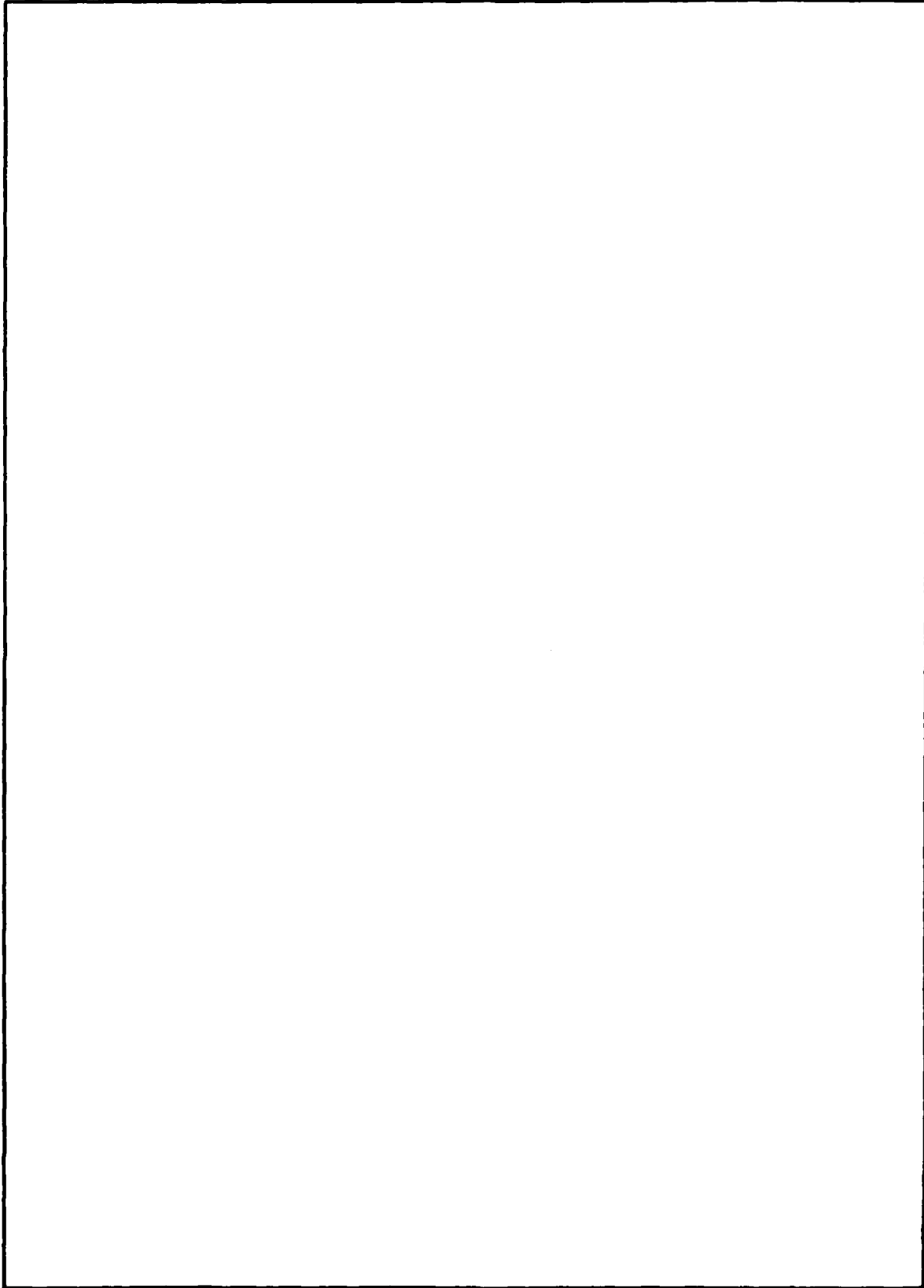

UNCLASSIFIED

SECURITY CLASSIFICATION OF THIS PAGE(When Data Entered)

CONTENTS

INTRODUCTION . . .	1
DERIVATION OF THE CONTROL SCHEME . . .	2
LIFT MODULE OPERATION . . .	2
COMPUTER SIMULATION . . .	3
FLOW CHARTS FOR THE ASCENT PROFILES . . .	5
RESULTS . . .	12
APPENDIX A: COMPUTER PROGRAM LISTING . . .	18

ILLUSTRATIONS

1. Lift module schematic . . .	2
2. Computer simulation interrelationships . . .	4
3. Hover logic diagram . . .	5
4. Logic common to all ascent profiles . . .	7
5. Logic for ascent/hover/descent . . .	8
6. Logic for ascent/hover/ascent . . .	9
7. Logic for 500-foot ascent . . .	10
8. Logic for diver selected . . .	11
9. Predicted and actual depth variations during hover . . .	13
10. Error in sensed depth due to seas (lift module sitting on bottom) . . .	13
11. Recorded depth and calculated speed during ocean test . . .	14
12. Lift module during the tests . . .	16
13. Lift module during the tests . . .	16
14. Lift module during the tests . . .	17
15. Lift module during the tests . . .	17

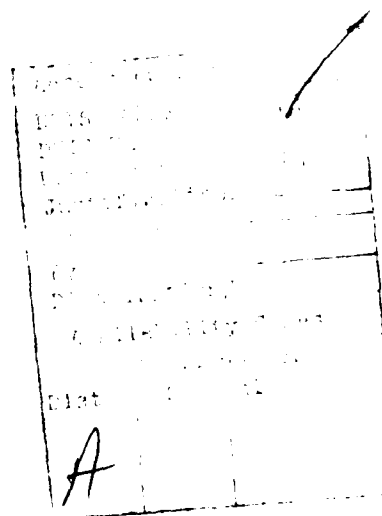

OBJECTIVE

Develop control logic for the microprocessor controlled lift module which will allow it to perform either preprogrammed or diver selected modes of operation, including ascent or descent at specific speeds and automatic hovering.

RESULTS

An experimental, totally self-contained lift module has been demonstrated which was controlled by a microprocessor in preprogrammed or diver selected modes of operation. These included ascent or descent at specific speeds and midwater hovering. The output of the computer simulation which was used to develop the control logic for the microprocessor agreed favorably with the test results.

RECOMMENDATIONS

1. The ability of the lift module to hover could be improved with an analytically based control scheme derived by a control engineer.
2. A more effective control scheme for construction applications might call for a control panel on which the diver could set a depth to which he wants to ascend or descend.

INTRODUCTION

A self-contained lift module was designed and fabricated during 1979 for a demonstration of the use of buoyant lift by a remote control vehicle. During 1980 the system was modified so that it could be controlled by a microprocessor to produce specific preprogrammed ascent profiles, including variable ascent and descent velocities and automatic hovering. It was further modified so that a diver could select microprocessor assisted automatic ascent, descent and hover modes of operation, or total manual control.

The ascent profiles that were selected for programming on the microprocessor were not devised with any particular operational scenario in mind, but were intended to demonstrate the lift module's capability of providing finely controlled buoyant lift forces. The profiles are:

1. Ascent/Hover/Descent. The lift module is placed on the bottom under manual control by divers. After the microprocessor is switched to automatic control, the module ascends at a preprogrammed speed to a depth of 40 feet, hovers at that depth for three minutes, and then descends to the bottom at a preprogrammed descent speed.
2. Ascent/Hover/Ascent. After divers place the lift module on the bottom under manual control, it ascends to 40 feet, hovers at that depth for three minutes, and then ascends to the surface.
3. 500 Ft Ascent. The lift module is lowered on a wire rope to a depth of 500 feet. It then ascends automatically to a depth of 100 feet at a speed of 2 ft/sec, and then reduces its speed to 1 ft/sec for the rest of the ascent to the surface.
4. Diver Selected. The diver sets switches to select ascent or descent at preprogrammed speeds, or automatic hover.

This report is intended to document development of the control schemes. Descriptions of the mechanical aspects of the lift module and of the tests that were run will be included in other reports.

DERIVATION OF THE CONTROL SCHEME

LIFT MODULE OPERATION

The lift module's buoyancy is provided by a 3200-lb-capacity fixed volume lift bag (figure 1). This closed lift bag is always kept fully inflated at a few psi over ambient pressure. That portion of its volume which is not filled with air to provide buoyancy is filled with water to provide ballast. To increase the buoyancy, water is let out of the bag through a water valve. Water is pumped into the bag to decrease its buoyancy. The water valve and pump are actuated by a microprocessor which can be preprogrammed or operated under diver control.

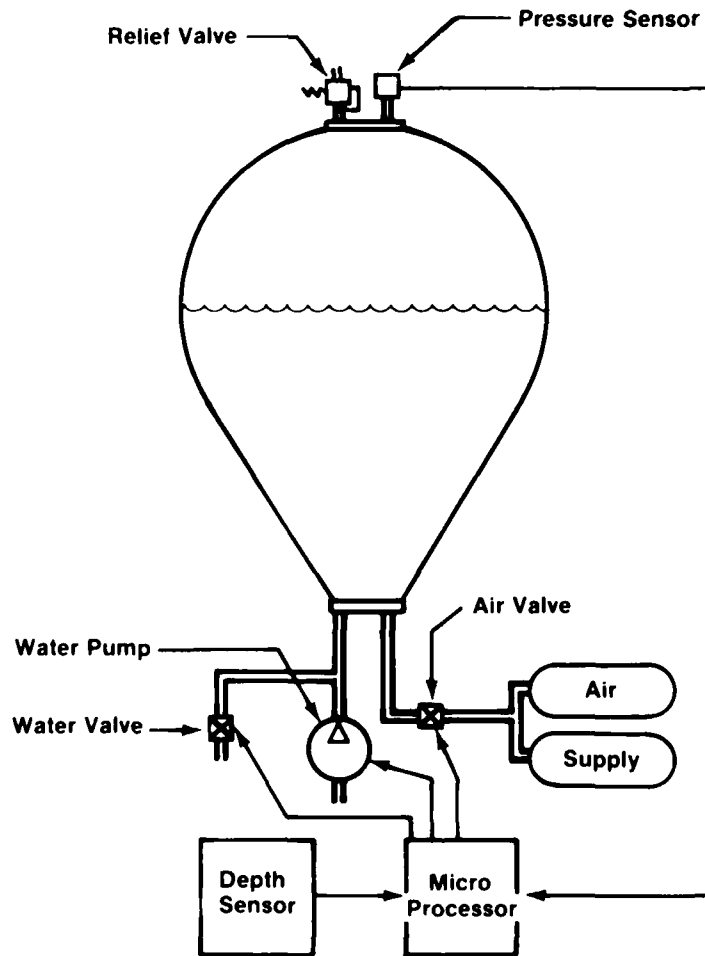

Figure 1. Lift module schematic

If water is let out of the bag or the lift module is descending, the microprocessor senses low pressure in the bag and opens the air valve to restore the internal pressure. When water is pumped into the bag or the lift module is ascending, excess air is vented out the relief valve at the top of the bag.

COMPUTER SIMULATION

Since at-sea testing is expensive, a computer simulation of the lift module was devised to test various candidate control schemes. A block diagram of the interrelationships between the microprocessor, the mechanical components of the lift module, and the dynamics of the lift module is shown in figure 2.

The dynamics of the lift module are a function of its net weight or net buoyancy, its mass, and its hydrodynamic drag. If the convention is chosen of depth, z , being positive downward, then a positive net force on the lift module is its net weight, W . Net buoyancy would then be considered as a negative net weight. If the lift module's mass is M , and its drag coefficient times area is C , the equation of motion becomes:

$$(1) \quad M\ddot{z} = W - C|\dot{z}|z$$

During a small time increment Δt , the lift module's depth changes by:

$$(2) \quad (z)_{\text{New}} = (z)_{\text{Old}} + \dot{z}\Delta t + 1/2 \ddot{z}\Delta t^2$$

The new velocity at the end of this time increment is:

$$(3) \quad (\dot{z})_{\text{New}} = (\dot{z})_{\text{Old}} + \ddot{z}\Delta t$$

These equations can be iterated to simulate the movement of the lift module.

In all of the ascent profiles, the microprocessor is required to control only three basic modes of operation: ascent or descent at a specific speed, or hovering in midwater.

It is relatively easy to control the lift module's speed of ascent or descent. Since drag is a function of the square of velocity, fairly large net-weight changes produce rather small velocity changes. It is sufficient to calculate speed from the change in depth from one time increment to another and either pump in or let out water as required to accelerate or decelerate.

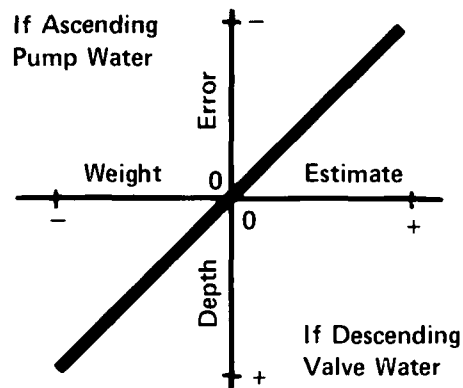

Figure 3. Hover logic diagram

FLOW CHARTS FOR THE ASCENT PROFILES

An attempt was made to use as many common subroutines as possible in the various profiles. In all of them a provision was included to allow a diver to set up the lift module for tests and to intervene if necessary. There are three switches available to the diver for use in controlling the lift module through the microprocessor. These are:

1. Switch S-2. Auto/Manual. Open indicates manual mode of operation is desired. Closed indicates automatic mode is desired.

2. Switch S-3. In the manual mode of operation, closing this switch indicates that operation of the water valve is desired. This switch is ignored in all the preprogrammed ascent profiles except the "Diver Selected" one. In this one, this switch indicates that automatic ascent is desired.

3. Switch S-4. In the manual mode, this switch indicates that operation of the water pump is desired. It is ignored in all the automatic ascent profiles except the "Diver Selected" profile, in which it indicates that an automatic descent is desired.

The other inputs into the microprocessor are:

4. Switch BPS. (Bag Pressure Switch.) When this switch is closed, the pressure inside the fixed volume lift bag is at the correct pressure. When it is open the pressure is too low, and operation of the air valve is required to put more air into the bag.

5. Pressure Sensor. For all the profiles except the "500-ft Ascent", a 0-150-psi sealed strain gauge pressure sensor is used. This sensor has a 0-5-vdc output which is converted by an A/D converter to a 12-bit digital number for use in the microprocessor. Thus, the conversion from microprocessor depth units to feet of depth is $33.7/4096$. The profile "500-ft Ascent" requires the use of a 0-500-psi sensor. Since the internal reference in this sensor is a vacuum, the conversion from microprocessor depth units to feet of depth is:

$$\text{Depth} = \frac{1122}{4096} (Z9) - 33 \quad (\text{where } Z9 \text{ is the depth in microprocessor units})$$

The parameters used in the microprocessor are:

- B5 - Estimated pump and valve flow rates. (3 lbs./sec) (9 μ P units/sec)
- C9 - Estimated lift module drag coefficient times area. (50 ft²) (1 μ P unit)
- M9 - Estimated lift module mass. (150 slugs) (75 μ P units)
- S2 - Desired ascent or descent speed.
(1 ft/sec) (12 μ P units/sec) in "500-ft Ascent". (.7 ft/sec)
(9 μ P units/sec) in the rest of the profiles.
- S3 - Allowable error in ascent or descent rate. (0.2 ft/sec) (3 μ P units/sec)
- Z5 - Required depth of hover. (40 ft) (486 μ P units)
In the "Diver Selected" profile this is a variable.
- Z8 - Bottom depth minus 10 feet. (60 ft) (729 μ P units)

The variables used in the microprocessor are:

- W1 - Estimated module net weight
- Z9 - Current depth
- Z6 - Depth at previous time increment
- S1 - Calculated ascent or descent speed
- F1 - Flag indicating current portion of profile (0,1,2)
- T8 - Time since start of hover.
- P1 - Pump status (0 - Pump off; 1 - Pump on)
- V1 - Water valve status (0 - Valve closed; 1 - Valve open)

The equations which are used to calculate an estimated module net weight are obtained from equations 1-3. Since the depth sensor input to the microprocessor calculations has a finite resolution, the calculated velocity and acceleration are noisy. Therefore, the weight estimate is weighted 0.1 from equations 1-3 and 0.9 from the estimated water valve and pump flow rate. Because the microprocessor is an integer machine, the equations are set up so that intermediate results are not lost due to underflow.

Flow charts for the various ascent profiles are given in figures 4-8.

COMMON TO ALL ASCENT PROFILES

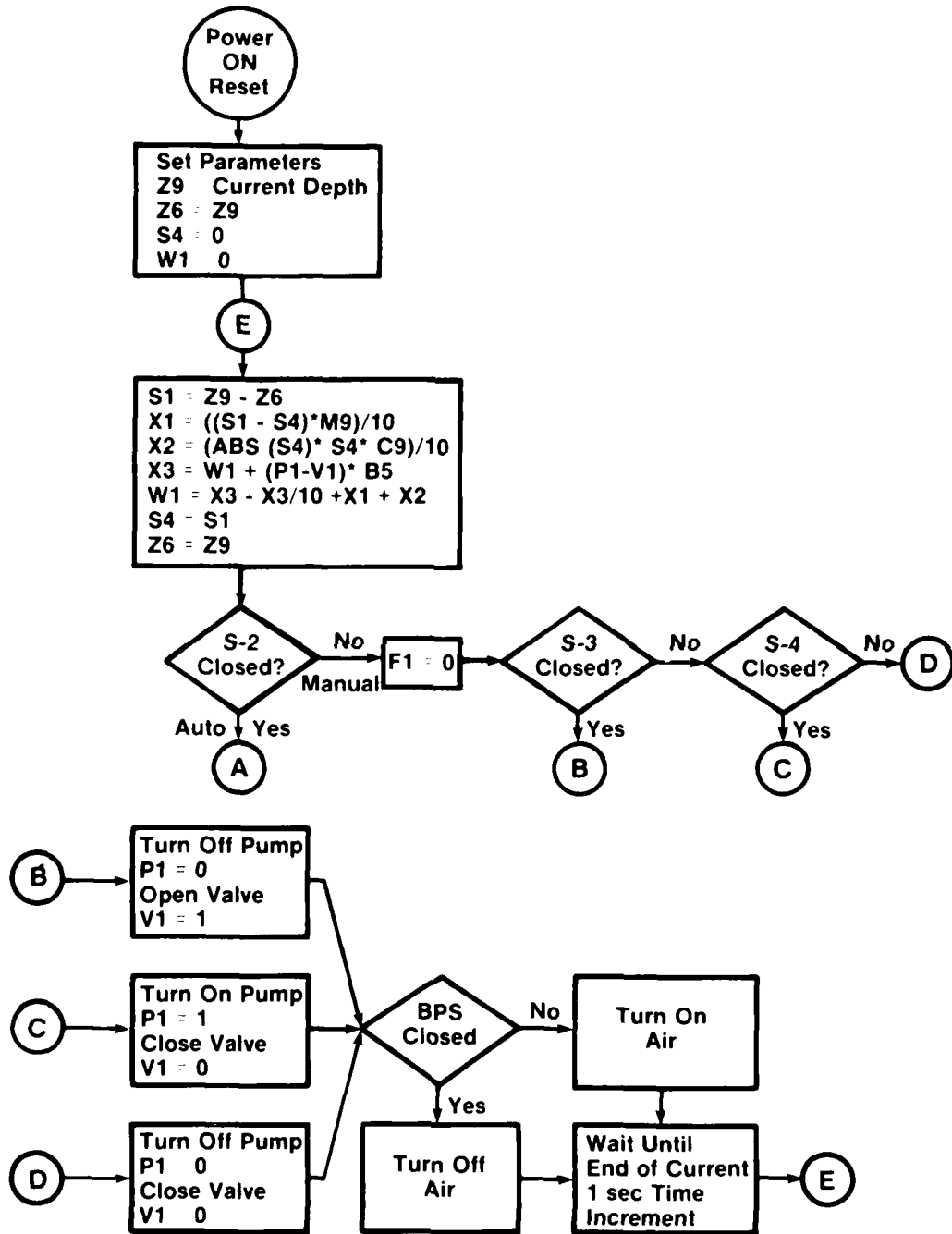

Figure 4. Logic common to all ascent profiles

ASCENT/HOVER/DESCENT

$F1 = 0 \rightarrow$ Ascend from Bottom to 40 ft
 $= 1 \rightarrow$ Hover at 40 ft for 3 min
 $= 2 \rightarrow$ Descend to Bottom

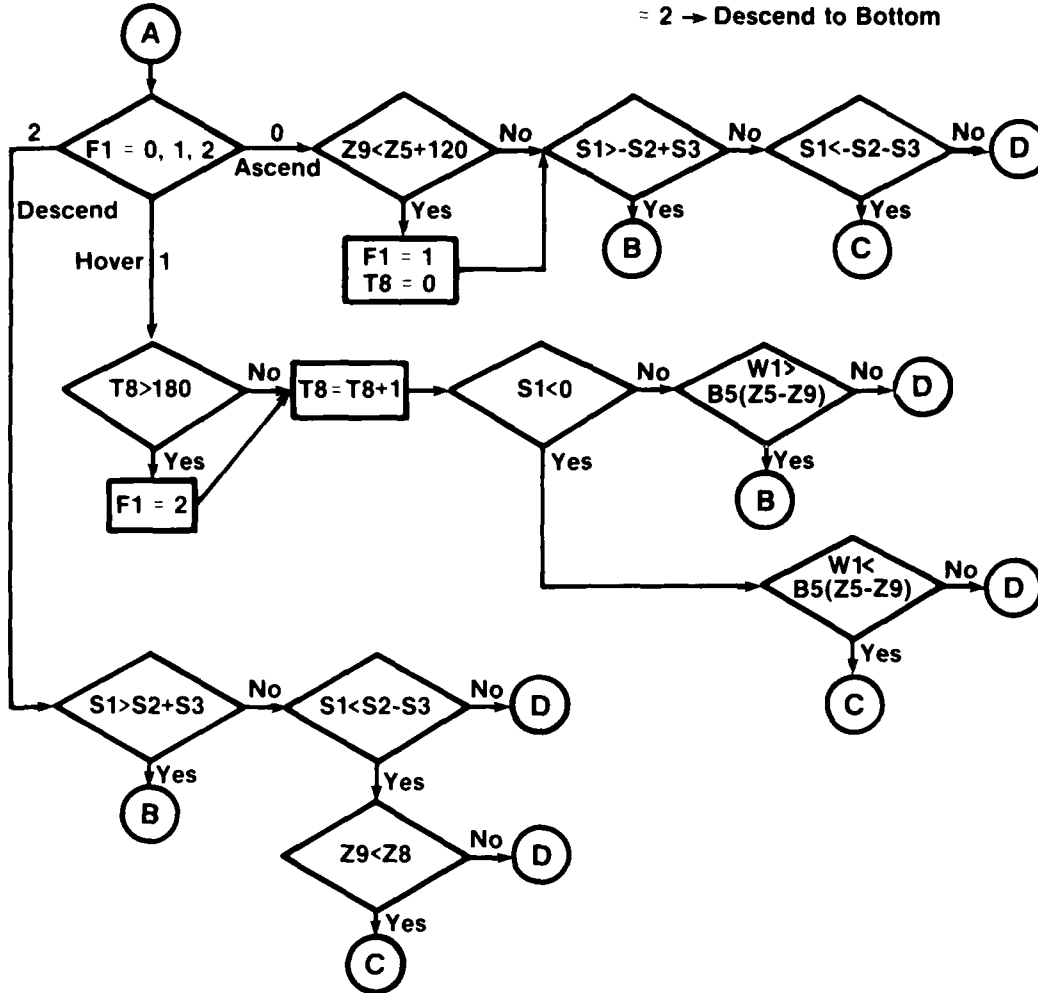

Figure 5. Logic for ascent/hover/descent

ASCENT/HOVER/ASCENT

F1 = 0 → Ascend from Bottom to 40 ft
 = 1 → Hover at 40 ft for 3 min
 = 2 → Ascend to Surface

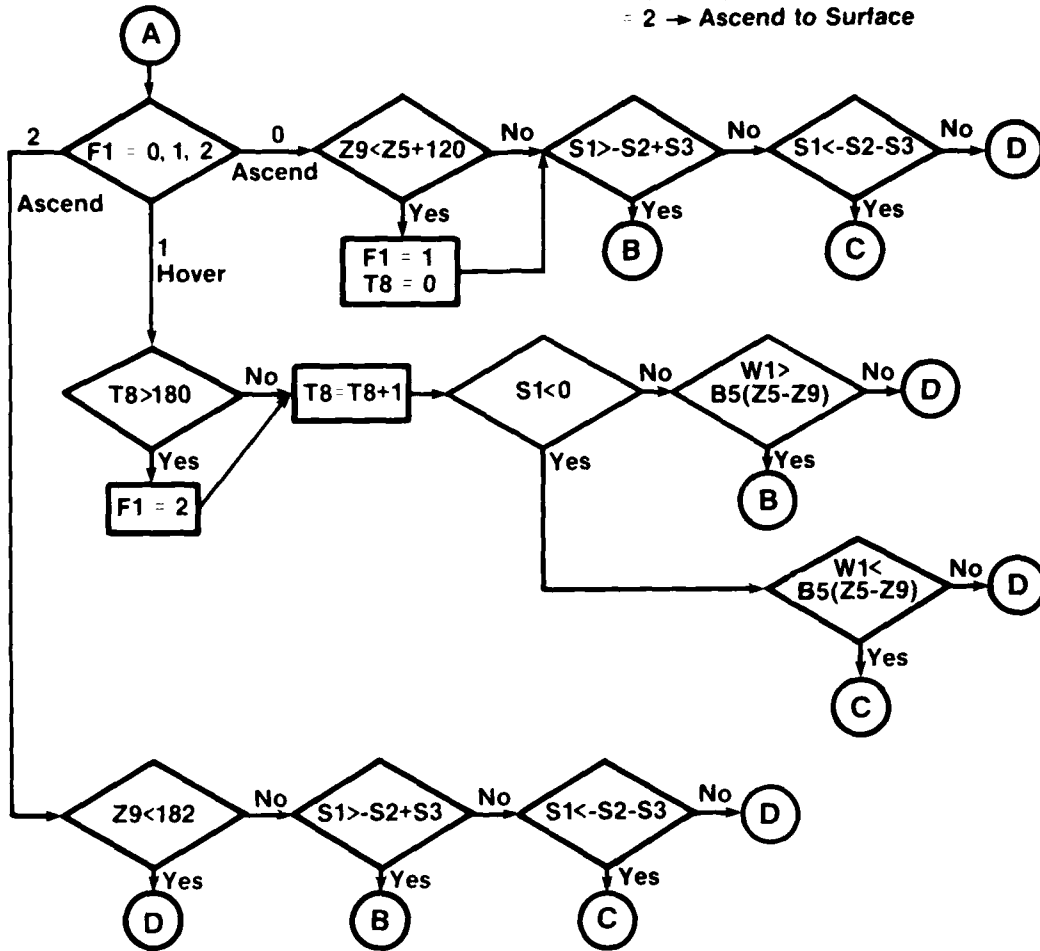

Figure 6. Logic for ascent/hover/ascent

500 FT ASCENT

- F1 = 0 → Lowering Lift Module
- = 1 → Ascending to 100 ft at $2 \cdot S2 = 2$ ft/sec
- = 2 → Ascending to Surface at $S2 = 1$ ft/sec

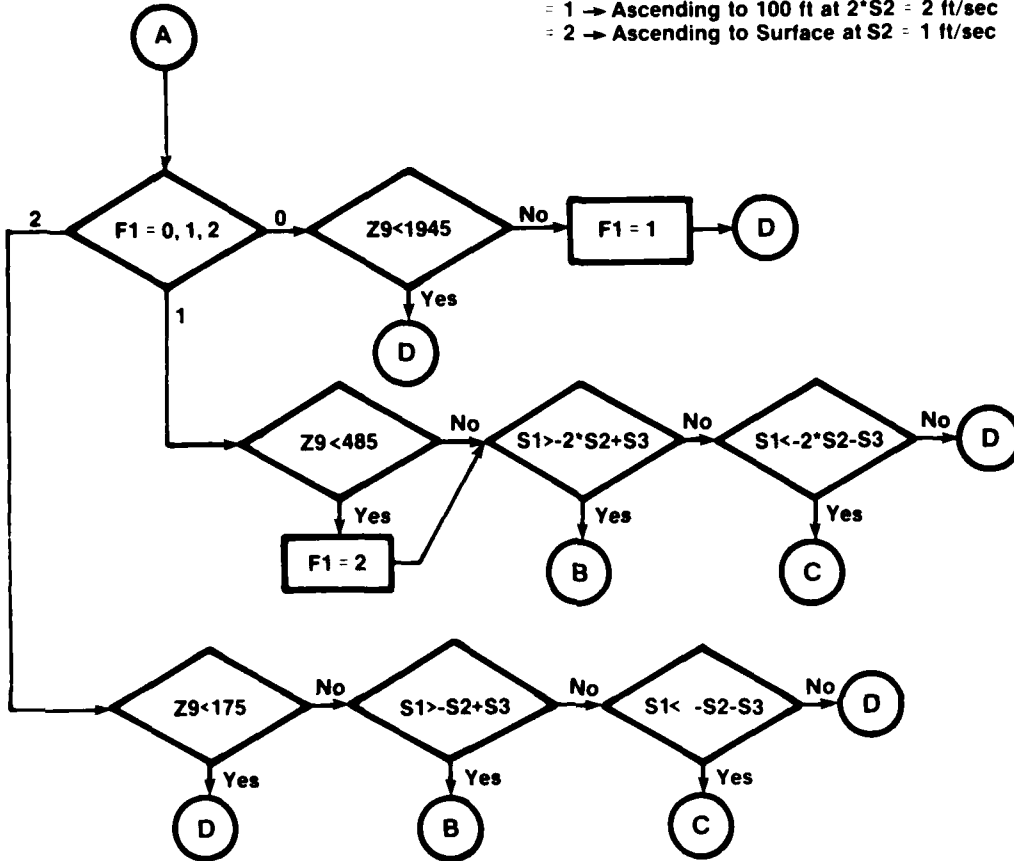

Figure 7. Logic for 500-foot ascent

DIVER SELECTED

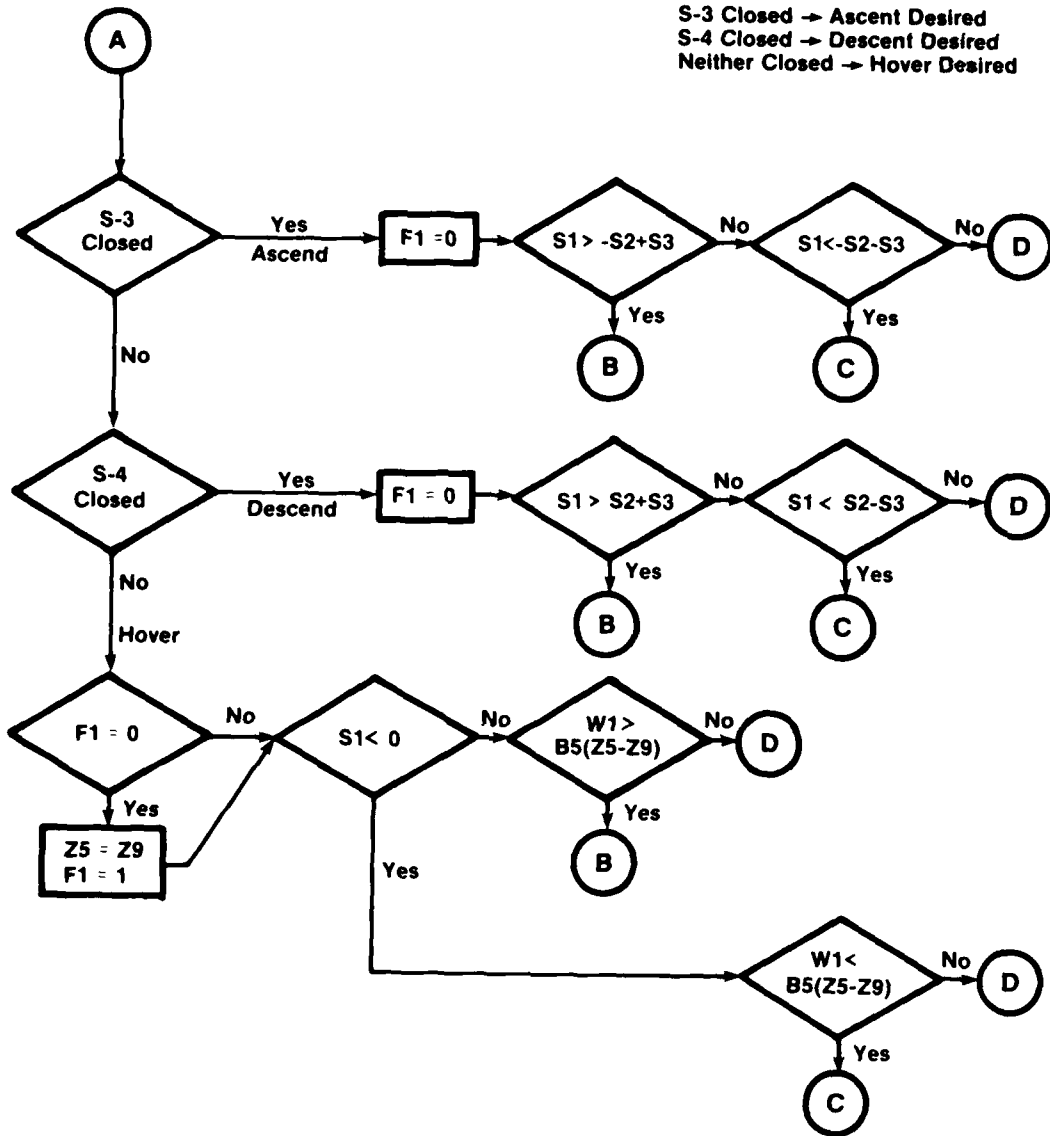

Figure 8. Logic for diver selected

RESULTS

All the ascent profiles were successfully demonstrated at sea. In fact, the tests were remarkably free of either mechanical or electronic failure.

The microprocessor on the lift module contained a tape recorder which was used to record, among other things, the values of the variables used in the control schemes. Figure 9 compares the depth changes recorded from an actual at-sea operation with those which were predicted by the computer simulation for the "Ascent/Hover/Ascent" ascent profile.

The ± 4 -foot oscillation shown in figure 9 during the hover phase of the ascent is typical of the microprocessor controlled hovers. A diver, using the bottom as a reference, could usually hold a manually controlled hover to ± 2 feet as long as his concentration did not waver.

One source of error in hover control was due to the presence of a long period ocean swell with a 3-4 ft amplitude during most of the tests. This introduced an error into the depth sensor input to the microprocessor. Figure 10 shows the depth error recorded while the lift module was sitting on the bottom during one of the tests.

Another source of hover error was due to the finite resolution of the depth sensor and the noise that this introduced into the calculated lift module speed. The 12-bit A/D converter on the output of the 150-psi depth sensor caused a depth resolution of $337/4096 = 0.08$ ft. If the depth resolution of the 500-psi sensor, 0.3 ft is used in the simulation, the predicted hover error is increased from ± 1 ft to ± 2 ft.

A combination of both these effects can be seen in figure 11. The bumps on the depth trace are due to seas passing overhead, while the noise on the calculated velocity is due to both the seas and the finite resolution of the depth sensor.

The fact that very small net weight or net buoyancy changes occur during hovering was demonstrated by hanging a 20-lb weight beneath the lift module. The module's buoyancy could be adjusted easily to keep the line to the weight taut without lifting it off the bottom.

The control scheme used for hover control was devised by intuitive reasoning and trial and error in the computer simulation. The ability of the lift module to hover could undoubtedly be improved with an analytically based scheme derived by a control engineer.

The "Diver Selected" mode of operation was intended to be a first cut at what might be used by a diver on underwater construction jobs. It was not too successful in that sense, since the lift module would always be either ascending or descending when switched into automatic hover and therefore would always overshoot its hover depth.

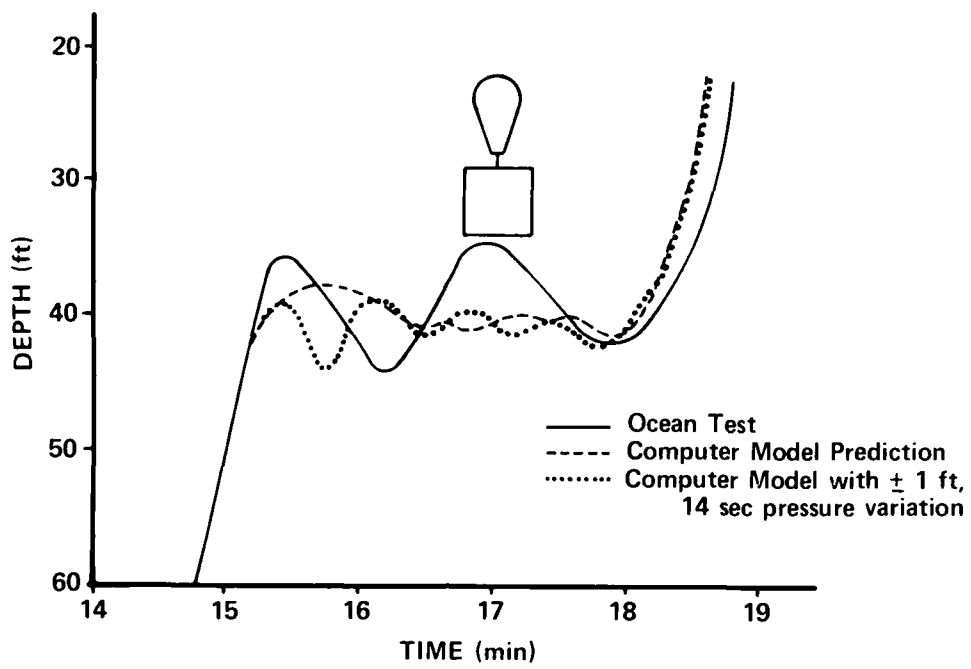

Figure 9. Predicted and actual depth variations during hover

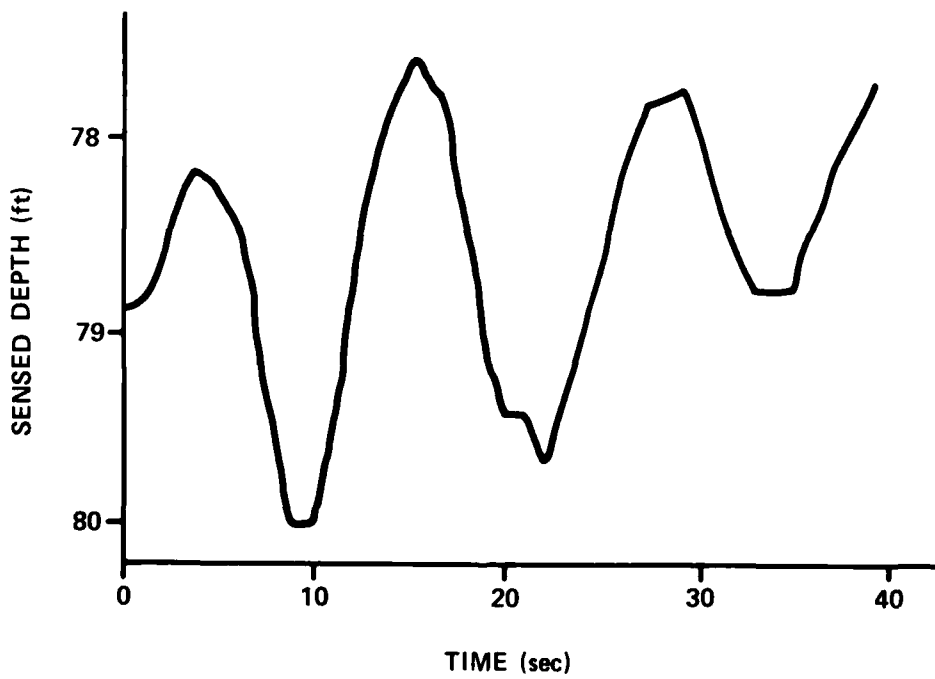

Figure 10. Error in sensed depth due to seas (lift module sitting on bottom)

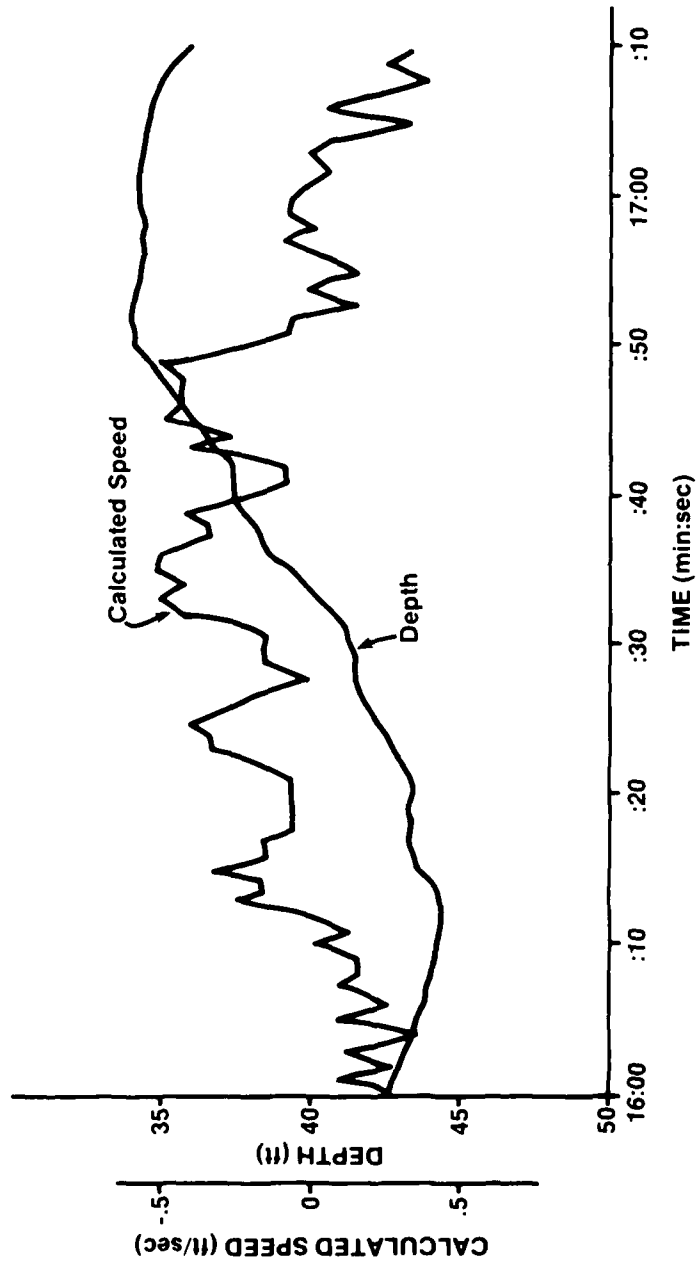

Figure 11. Recorded depth and calculated speed during ocean test

A more effective control scheme for construction applications might call for a control panel on which the diver could set a depth to which he wants to ascend or descend. The microprocessor could then anticipate reaching that depth and decelerate gradually to avoid overshoot.

However, the simplest and probably the most effective way to hold a load at fixed height off the bottom is to hang a small weight from the load on the proper length of line and allow the weight to rest on the bottom.

Figures 12-15 show the lift module during the tests.

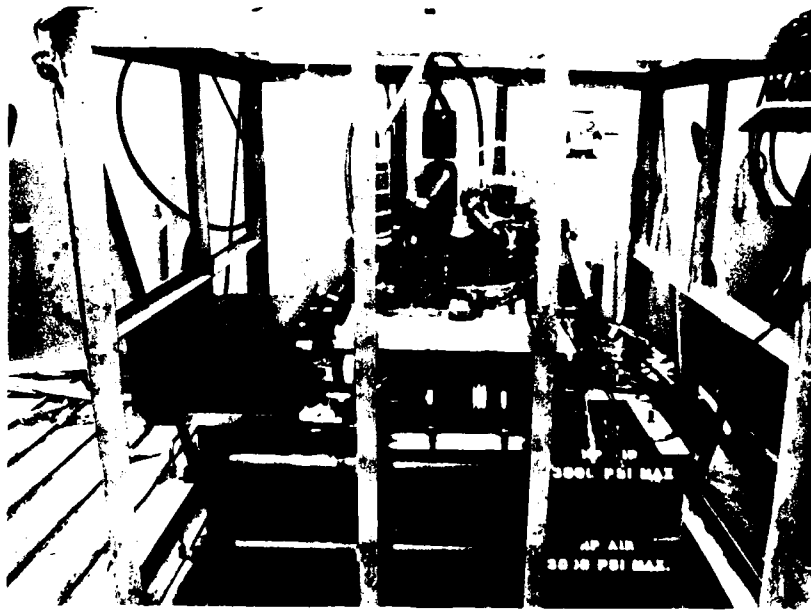

Figure 12. Lift module during the tests

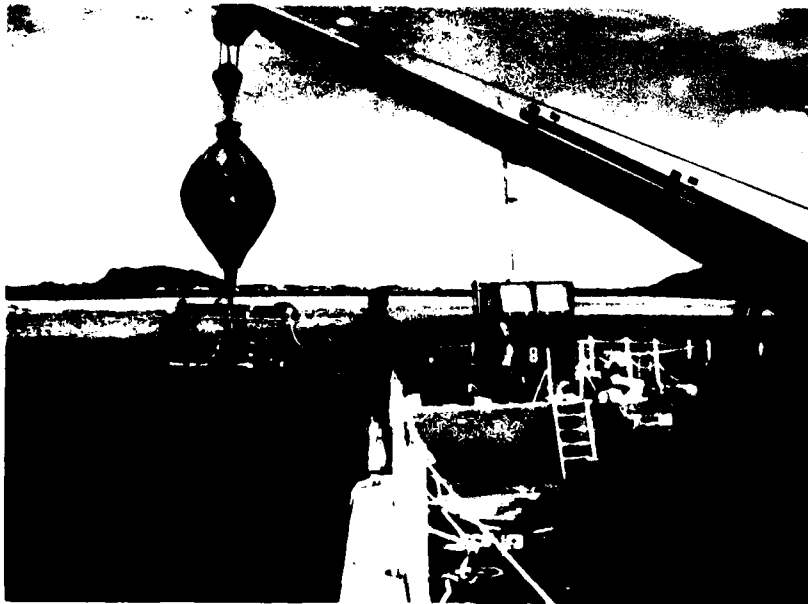

Figure 13. Lift module during the tests

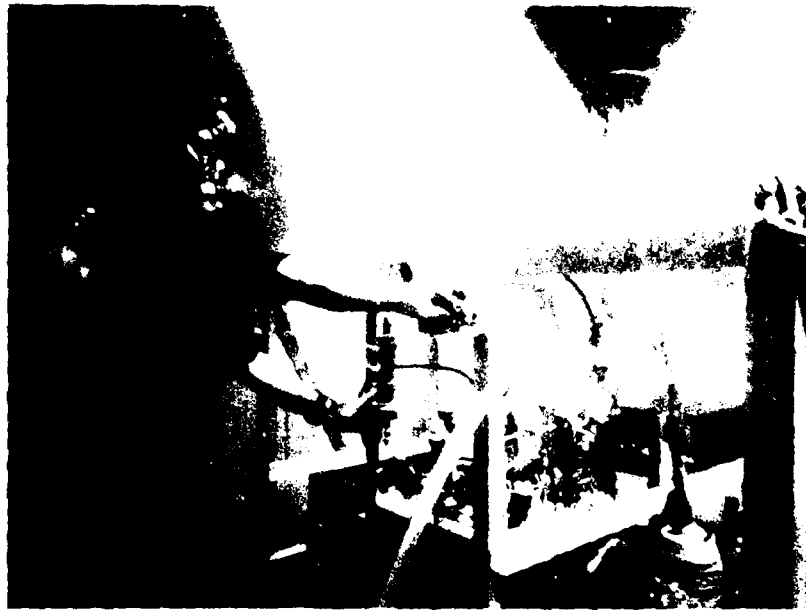

Figure 14. IIT module during the tests



Figure 15. IIT module during the tests

APPENDIX A - COMPUTER PROGRAM LISTING

```

10 REM LIFT MODULE MODEL
12 OPEN "O", #6, ":LP:"
14 OPEN "O", #5, ":CO:"
16 N=6
20 READ M1,C1,W,Z1,Z8
30 READ M9,C9,Z5
40 READ P3,P4,P5
50 READ V3,V4,V5
60 READ B5
70 READ S2,S3
80 READ T3
90 T1=0
100 Z2=0
110 F1=0
120 W1=0
130 T2=.25
140 N1=4
150 Z9=INT(Z1*4096/337)
160 Z6=Z9
180 PRINT #N, "          INPUT DATA"
190 A$="M1=####.#  C1= ###.#  W=#####.  Z1=####.  Z8=####."
200 PRINT #N, USING A$;M1,C1,W,Z1,Z8
210 A$="M9=####.#  C9=####.#  Z5=####."
220 PRINT #N, USING A$;M9,C9,Z5
230 A$="PUMP          P3=###.#  P4=###.#  P5=###.#"
240 PRINT #N, USING A$;P3,P4,P5
250 A$="WATER VALVE  V3=###.#  V4=###.#  V5=###.#"
260 PRINT #N, USING A$;V3,V4,V5
270 A$="ESTIMATED RATE                    B5=###.#"
280 PRINT #N, USING A$;B5
290 A$="DESIRED SPEED  S2=###.#  S3=###.##"
300 PRINT #N, USING A$;S2,S3
310 A$="TIME          T2=###.##  N1=####.  T3=####."
320 PRINT #N, USING A$;T2,N1,T3
330 PRINT #N,
340 PRINT #N, "  T1    Z1    Z2      W    F1    S1    W1    P1
350 A$= "#### ##.#  ##.#  ####  ###  ##.#  ####  ###  ##.#  #
360 GOSUB 450
370 FOR N2=1 TO N1
380 GOSUB 810
390 GOSUB 960
400 T1=T1+T2
410 NEXT N2
420 PRINT #N, USING A$;T1,Z1,Z2,W,F1,S1*3377/4096,W1/3,P1,P2,V1,V
430 IF T1<T3 THEN 360
440 GOTO 1110
450 REM SUBROUTINE***MICROPROCESSOR***
460 REM PROFILE-----ASCENT/HOVER/ASCENT                                ADAPTIVE CONTRC

```

```

470 S1=Z9-Z6
475 X1=INT((S1-S4)*M9/10)
480 X2=INT((ABS(S4)*S4*C9)/10)
485 X3=W1+(P1-V1)*B5
490 W1=X3 - INT(X3/10) + X1 + X2
495 S4=S1
500 Z6=Z9
510 IF F1=1 THEN 580
520 IF F1=2 THEN 670
530 IF Z9<Z5+121 THEN F1=1
540 T8=0
550 IF S1>-S2+S3 THEN 750
560 IF S1<-S2-S3 THEN 780
570 GOTO 720
580 IF T8>180 THEN F1=2
590 T8=T8+1
600 IF S1<0 THEN 640
610 IF W1>INT(B5*(Z5-Z9)/12) THEN 750
620 REM
630 GOTO 720
640 REM
650 IF W1<INT(B5*(Z5-Z9)/12) THEN 780
660 GOTO 720
670 IF S1>-S2+S3 THEN 750
680 IF S1<-S2-S3 THEN 700
690 GOTO 720
700 IF Z9<Z8*4096/337 THEN 780
720 P1=0
730 V1=0
740 GOTO 800
750 P1=0
760 V1=1
770 GOTO 800
780 P1=1
790 V1=0
800 RETURN
810 REM SUBROUTINE***MODULE MECHANICAL***
820 IF P1=0 THEN 860
830 P2=P2+P5*T2/P3
840 IF P2>P5 THEN P2=P5
850 GOTO 880
860 P2=P2-P5*T2/P4
870 IF P2<0 THEN P2=0
880 IF V1=0 THEN 920
890 V2=V2+V5*T2/V3
900 IF V2>V5 THEN V2=V5
910 GOTO 940
920 V2=V2-V5*T2/V4
930 IF V2<0 THEN V2=0
940 W=W+P2*T2-V2*T2
950 RETURN
960 REM SUBROUTINE***DYNAMICS***

```

```
970 Z3=(W-D1*ABS(Z2)*Z2)/M1
980 Z1=Z1+Z2*T2+(Z3*T2^2)/2
990 Z2=Z2+Z3*T2
1000 IF Z1<10 THEN Z1=10
1010 IF Z1>Z8+11 THEN Z1=Z8+11
1020 Z9=INT(Z1*4096/337)
1030 RETURN
1040 DATA 150,50,0,80,70
1050 DATA 75,1,486
1060 DATA 2,2,3
1070 DATA 2,2,3
1080 DATA 9
1090 DATA 9,3
1100 DATA 500
1110 END
```

END

DATE
FILMED

4-8-1

DTIC