

AD-A096 540

AERONAUTICAL RESEARCH LABS MELBOURNE (AUSTRALIA)
A MICROPROCESSOR CONTROLLED GRAPHICS DISPLAY SYSTEM. (U)
MAR 80 C W SUTTON, J F HARVEY, G A CLEAVE
ARL/AERO NOTE-396

F/6 9/2

UNCLASSIFIED

NL

1 of 1
AD-A
096540

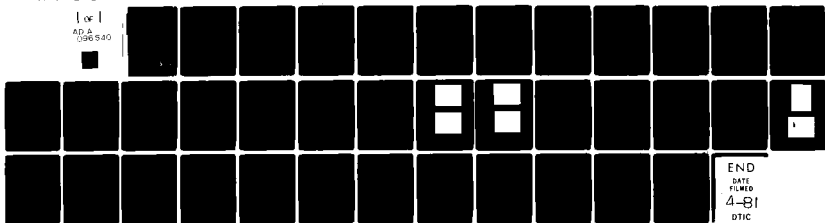

END
DATE
FILMED
4-81
DTIC

TW

1971 #12



AD A 096540

**DEPARTMENT OF DEFENCE
DEFENCE SCIENCE AND TECHNOLOGY ORGANISATION
AERONAUTICAL RESEARCH LABORATORIES
MELBOURNE, VICTORIA**

AERODYNAMICS NOTE 396

**A MICROPROCESSOR CONTROLLED
GRAPHICS DISPLAY SYSTEM**



by

C. W. SUTTON, J. F. HARVEY and G. A. CLEAVE

Approved for Public Release.



DTIC
ELECTE
MAR 19 1981
A

© COMMONWEALTH OF AUSTRALIA 1980

COPY No 20

MARCH 1980

DISC FILE COPY

X

DEPARTMENT OF DEFENCE
DEFENCE SCIENCE AND TECHNOLOGY ORGANISATION
AERONAUTICAL RESEARCH LABORATORIES

(14) ARL/AERO NOTE-396

(9) AERODYNAMICS NOTE 308

(6) A MICROPROCESSOR CONTROLLED
GRAPHICS DISPLAY SYSTEM.

by

(10) C. W. SUTTON, J. F. HARVEY and G. A. CLEAVE

(11) Mar 80

(12) 38

SUMMARY

A graphics display system is described which functions as a peripheral of a data acquisition system, connected on-line to a time shared central computer. Under control of the central computer, multichannel scaled co-ordinate graphs and displays are generated on a storage display unit by a 16-bit microprocessor.

DOCUMENT CONTROL DATA SHEET

Security classification of this page: Unclassified

- | | |
|--|--|
| <p>1. Document Numbers</p> <p>(a) AR Number:
AR-001-809</p> <p>(b) Document Series and Number:
Aerodynamics Note 396</p> <p>(c) Report Number:
ARL-Aero-Note-396</p> | <p>2. Security Classification</p> <p>(a) Complete document:
Unclassified</p> <p>(b) Title in isolation:
Unclassified</p> <p>(c) Summary in isolation:
Unclassified</p> |
|--|--|

3. Title: A MICROPROCESSOR CONTROLLED GRAPHICS DISPLAY SYSTEM

- | | |
|--|--|
| <p>4. Personal Author(s):
C. W. Sutton,
J. F. Harvey, and
G. A. Cleave</p> | <p>5. Document Date:
March, 1980</p> |
|--|--|

- | | |
|---|--|
| <p>7. Corporate Author(s):
Aeronautical Research Laboratories</p> | <p>8. Reference Numbers</p> <p>(a) Task:</p> |
| <p>9. Cost Code:
55 6052, 57 7720, 55 7720</p> | <p>(b) Sponsoring Agency:</p> |

- | | |
|--|--|
| <p>10. Imprint
Aeronautical Research Laboratories,
Melbourne</p> | <p>11. Computer Program(s)
(Title(s) and language(s)):</p> |
|--|--|

12. Release Limitations (of the document)
Approved for Public Release

12-0. Overseas:	N.O.	P.R.	I	A	B	C	D	E
-----------------	------	------	---	---	---	---	---	---

13. Announcement Limitations (of the information on this page):
No Limitation

- | | | |
|---|--|-----------------------------------|
| <p>14. Descriptors:
Microprocessors
Computer graphics</p> | <p>Data acquisition
Wind tunnels</p> | <p>15. Cosati Codes:
1402</p> |
|---|--|-----------------------------------|

16. *ABSTRACT*
A graphics display system is described which functions as a peripheral of a data acquisition system, connected on-line to a time shared central computer. Under control of the central computer, multichannel scaled co-ordinate graphs and displays are generated on a storage display unit by a 16-bit microprocessor.

Accession For	
NTIS GRA&I	<input checked="" type="checkbox"/>
DOC TAB	<input type="checkbox"/>
Unannounced	<input type="checkbox"/>
Justification	
Distribution/	
Availability Codes	
Avail and/or	
Special	

CONTENTS

	Page No.
1. INTRODUCTION	1
2. DESCRIPTION	1
2.1 General	1
2.2 Microprocessor	1
2.3 Resolution	4
2.4 Deflection Sensitivity	4
3. COMMUNICATION	6
3.1 Network	6
3.2 Format of Strings	6
3.2.1 Mode	7
3.2.2 Axis	8
3.2.3 Dot	9
3.2.4 Clear	10
3.2.5 Text	10
3.2.6 PLOT file	10
3.2.7 Wipe	10
4. SOFTWARE	13
4.1 Control Program	13
4.2 Main Program	13
4.2.1 Display	13
4.2.2 Program speed	14
4.2.3 Logic description	14
4.3 Support Program	17
4.3.1 UART service routine	17
4.3.2 Buffer management routine	17
4.3.3 Line drawing program	20
4.3.4 Vector generation	20
4.3.5 Debug program	23
5. HARDWARE	23
5.1 Card Set	23

5.2 Central Processing Unit	26
5.3 1K RAM Card	26
5.4 2K EPROM Card	26
5.5 Character Generator Card	26
5.6 UART Interface Card	27
5.7 DEBUG Control Card	27
5.8 D-A Converter Card	27
5.9 Input/Output Interface and Address Decoder Cards	28
5.10 Power Supply Card	28
5.11 Construction	28
6. OPERATING INSTRUCTIONS	29

ACKNOWLEDGMENTS

REFERENCES

DISTRIBUTION

1. INTRODUCTION

A real time graphics display system has been built around an existing Tektronics 611 storage display unit and a National Semiconductor Corporation PACE microprocessor. The graphics system is installed as part of the Low Speed Wind Tunnel data acquisition system for quick look evaluation of real time aerodynamic data.

Raw data from the data acquisition system are fed on-line to a central DEC system-10 computer where selected data, after processing, are transmitted back to the tunnel control room for storage and display by the graphics display unit.

Operational experience with this quick look graphics display system supports the need for such a facility. A larger screen system is now envisaged for permanent use in the tunnel control room.

2. DESCRIPTION

2.1 General

The graphics system has the capability to store and display, on scaled coordinates, data associated with up to 8 independent channels. To avoid unnecessary repetitive transmission of data, 2048 (2K) of 16 bit word Random Access Memory (RAM) has been initially allocated within the graphics system for data storage.

This memory allocation allows six channels (A to F) to each have a storage capacity of 68 data points. These six channels are intended to display, on scaled coordinates, the data corresponding to the six aerodynamic coefficients (lift, drag, side force, pitch, roll and yaw against model attitudes). The seventh channel (G) has a storage capacity of 67 data points and the eighth channel (H) is able to store either 39 data points or 376 text characters. The G and H channels are intended for display of hinge moments or pressure profiles. Text messages are confined to the H channel.

Memory allocation for channel data (Table 1) is consecutive from 0100-07BF and no limit is incorporated into the control software to prevent an excessive number of data points associated with a leading channel from overwriting into the storage area allocated to a following channel. Thus, for a selective choice of channels, the data point storage capacity of some channels is able to be increased by reducing the number of selected channels. For example, the storage capacity of channels A and B is more than doubled to 128 data points by overwriting into channels C and D. All data and text are stored as 8 bit words and packed into either the high or low byte section of memory as shown in Table 1. The number of locations required to store a datum point is detailed in Section 3.2.

Channel selection is completely optional except that text messages must be assigned to the H channel. Software control allows any channel to be displayed singly, or any combination of channels to be displayed sequentially with a controllable display time. Alternatively, any combination of channels is able to be displayed simultaneously in non overlapping zones.

In addition, PLOT files from the DECsystem-10 may be viewed before generating a hard copy on a plotter peripheral of the DECsystem-10 computer. Data from PLOT files are not stored in the RAM of the graphics display system but are retained, for once only viewing, by the screen phosphor of the storage display unit.

2.2 Microprocessor

Control of the graphics display is by a 16 bit word PACE microprocessor with 1½ K of Erasable Programmable Read Only Memory (EPROM) for storage of the control program.

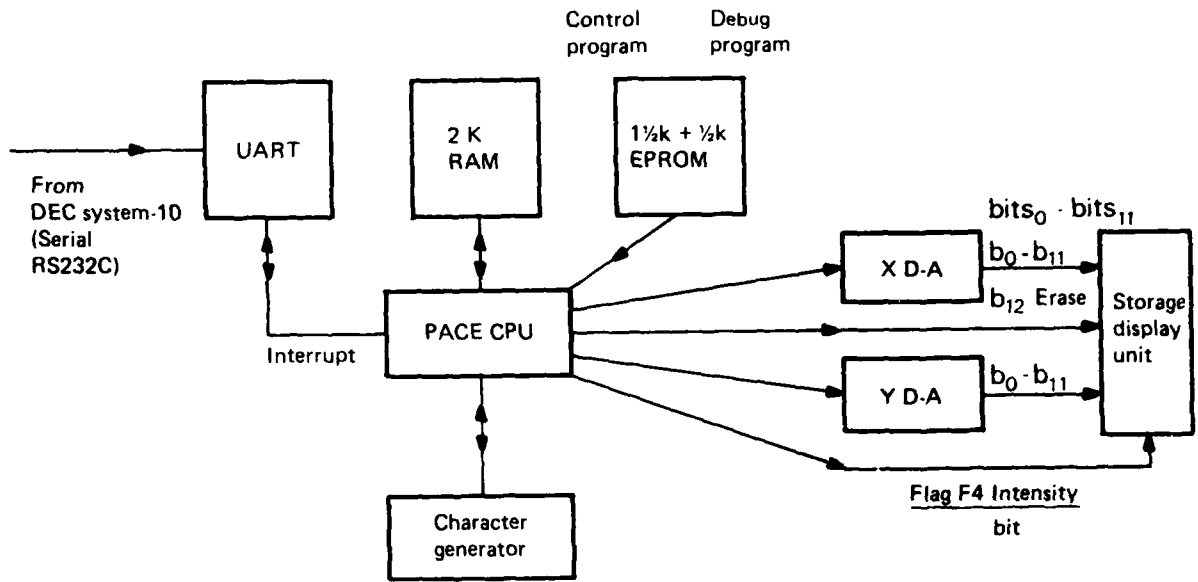

FIG. 1 GRAPHICS DISPLAY SYSTEM

A further 1/2 K of EPROM contains a modified version of the PACE DEBUG program to allow interrogation of the control program for fault diagnosis.

Communication between the DECsystem-10 computer and the graphics system is at 300 baud with an RS-232C serial interface to a Universal Asynchronous Receive Transmit (UART) integrated circuit (Fig. 1). An interrupt line of the microprocessor causes the UART to be read whenever characters are received from the DECsystem-10. These characters are stored in a circular buffer which, at specific points in the graphics control program, is searched for valid data or command strings.

When a valid string is detected and identified by the control program the contents are automatically read from the buffer and (except for PLOT file data) stored in a preassigned area of the RAM. The actual area depends on whether the string contains data or a command. The storage location for data is shown in Table 1 and is determined by the channel identifier contained in the string. A common storage area (see Note 3, Table 1) is allocated for commands.

Under the control of the EPROM program the microprocessor generates bit patterns in response to the command and available data. These patterns represent X and Y screen positions which are sent to the storage display unit through 12 bit Digital to Analogue (D-A) converters. The intensity (Z) line is pulsed to visually store the points on the 210 mm by 162 mm screen.

Alphanumerics for titles, scales and text are generated for display by a hardware character generator circuit (Section 5.5). Basically each character is displayed on a 7 x 5 dot matrix but characters derived from a PLOT file are software generated by numerous straight line vectors (Section 4.3.4).

TABLE 1

Assigned Memory Locations for Channel Data

Channel	40 Locations Reserved for Scaled Axis Data	Memory Reserved for Data Points	Memory Byte
A	0100-0127	(408 Locations) 0128-02C0	Low
B	0100-0127	0128-02C0	High
C	02C1-02E8	02E9-0481	Low
D	02C1-02E8	02E9-0481	High
E	0482-04A9	04AA-0642	Low
F	0482-04A9	04AA-0642	High
G	0643-066A	(239 Locations) 066B-07BF	Low
H (Axis)	0643-066A	066B-07BF	High
H (Text)	Total of 381 Locations	0643-07BF	High

- Note 1. The leading zero attached to the address of the above memory locations, signifies hexadecimal values.
2. Memory range 07C0-07FF (64 locations) is allocated to the circular buffer (Section 4.3).
3. Memory range 000-0FF (256 locations) is allocated as base page to the control program.

FIGURE 2.

Bit Allocation of D-A Converter

Bit	Approx. Display Deflection (mm)	Allocated Bit Range
LSB	b ₀	0.05
	b ₁	0.1
	b ₂	0.2
	b ₃	0.4
	b ₄	0.8
	b ₅	1.6
	b ₆	3.2
	b ₇	6.5
	b ₈	13.1
	b ₉	26.2
	b ₁₀	52.5
MSB	b ₁₁	105

* Produces Axis titles, scales and text with a character height of about 3 mm.

Note Deflection sensitivity is shown for X axis, the Y axis sensitivity is approximately 0.8 of the X axis sensitivity (See Section 2.4).

2.3 Resolution

The 12 bit D-A converters provide a resolution in both X and Y directions of 1 in 4096 (2¹²). However, data received from the DECsystem-10 (excluding PLOT files) are treated as consisting of 8 bit words (Fig. 2). Thus when data are graphed on scaled coordinates the data point position resolution is 1 in 256 (2⁸). This represents a position error of less than 1 mm on the 162 mm by 210 mm screen and is considered adequate for the present application. For comparison, the specified full scale linearity of the display unit is 10⁻⁶.

A data range of 256 has the advantage that all data remain within the 8 bit byte length of conventional American Standard Code for Information Interchange (ASCII) interface systems.

However, to reproduce faithfully the software generated alphanumerics of PLOT files a higher data resolution is needed, otherwise the minimum height of displayed characters is limited to about 5.6 mm compared with about 1.4 mm height attainable with the A-D converters. An increase in data resolution to 1 in 1024 (2¹⁰) is achieved by treating data as a combination of bits from two consecutive printable ASCII characters (Section 4.3.3). For a given baud rate the time taken in transmission of the higher resolution data is twice that needed for the lower resolution data.

2.4 Deflection Sensitivity

For a given rectangular screen a choice exists between:

- (1) a common deflection sensitivity in the X and Y directions but with different scale ranges; or
- (2) a common scale range in the X and Y directions but with different deflection sensitivities.

For general purpose applications choice (1) is preferable as there is no aspect distortion introduced with equal X and Y deflection sensitivities. Such distortion occurs in choice (2) where, without compensation, a circle displays as an ellipse.

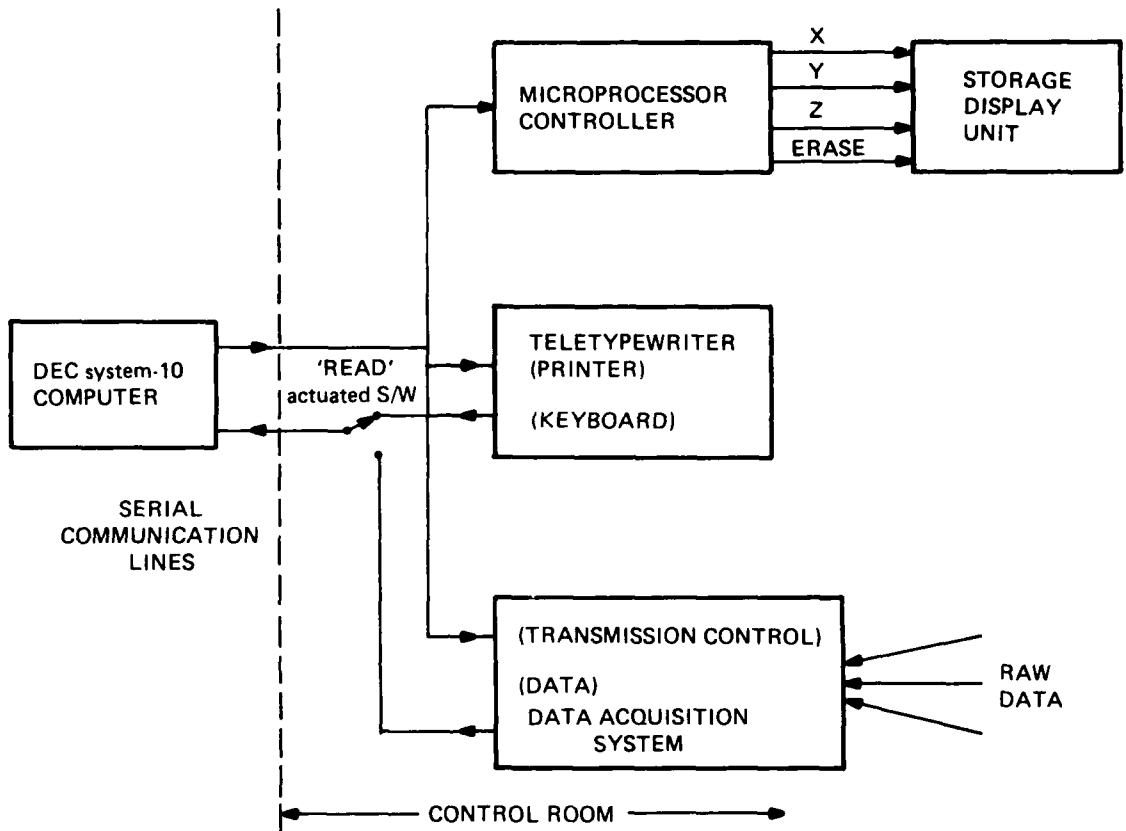

FIG. 3 SIMPLIFIED COMMUNICATION NETWORK

However, choice (2) is acceptable for coordinate axis graphics with scaled grids as such distortion has little significance and the common scale range is an advantage. For the graphics system described choice (2) applies, thus for a 162 mm by 210 mm screen the Y sensitivity is approximately 0.8 that of the X sensitivity. To compensate for this aspect ratio distortion when PLOT files are displayed, requires that the Y values of the data points be scaled by a factor of 1.2 before transmission to the graphics system from the DECsystem-10.

3. COMMUNICATION

3.1 Network

The graphics display system is connected, as an output device, to the DECsystem-10 computer (Fig. 3). Also connected to the same terminal line is the data acquisition system (basically an input device to the DECsystem-10) and a printer/keyboard peripheral (Teletypewriter Model 43). The data acquisition system is described in Reference 1.

In operation, the printer and the graphics system continually respond to characters transmitted by the DECsystem-10. The keyboard is normally the input device to the DECsystem-10. However, the input line automatically switches from the keyboard to the data acquisition system when the 'READ' button of the data acquisition system is pressed. Raw data, gathered by the data acquisition system, is echoed back to the printer after storage on disk by the DECsystem-10.

To avoid loss of raw data, because of terminal buffer overflow, hardware decoders (on the 'HOLD' line of the data acquisition system address generator) respond to both a control 'S' (X-off) representing a computer 'WAIT' and a control 'Q' (X-on) representing a computer generated 'CONTINUE'.

Although every character transmitted by the DECsystem-10 to the printer is checked by the graphic control software only certain combinations of characters are recognised and accepted as valid graphic strings.

TABLE 2

PROMPT Characters Recognised by Graphics Display Control Program

Character	Description	Octal Value	Hexidecimal Value
↑R	Control R	022	12
:	ASCII Characters	073	3B
L	ASCII Characters	114	4C
"/	ASCII Characters	100	40
S	ASCII Characters	123	53
H	ASCII Characters	110	48
G	ASCII Characters	107	47
U	ASCII Characters	125	55
C:R	Carriage Return	015	0D
↑T	Control T	024	14
GS	Control Shift M	035	1D
US	Control Shift O	037	1F
0	NULL	000	00

3.2 Format of Strings

Valid calls to the graphic display system involves the prompt characters listed in Table 2 with string combinations as detailed in Table 3. Except for text and PLOT file strings, which

TABLE 3

Strings Recognised by Graphics Display Control Program

String Name	String Format					
Mode	↑R :	Display Time	Type of Display	Channels for Display	Style	↑T
Axis	↑R L	Allocated Channel	Axis Scale Values	X Axis Title ,	Y Axis Title	↑T
Dot	↑R @	Allocated Channel	Symbol	Scaled Data Coordinates		
Clear	↑R @	NULL	↑T			↑T
Text	↑R S H	Coordinates of Leading Character		Alphanumeric Message		↑T
PLOT file	GS	Data String	US or Carriage Return			
Wipe	↑R S	NULL	↑T			

are of variable length, each string is checked on-arrival from the DECsystem-10 by the graphics control program for a predetermined number of characters.

Detailed descriptions of the strings are covered in the following sections.

3.2.1 Mode

The contents of the four blocks of the MODE String, shown in Table 3, are:

(1) DISPLAY TIME

A single upper case letter in the range A to Z is required in all mode strings but the character has significance only in the cyclic display mode. The letter sets the time that each selected channel is displayed.

For the range A to Y the 25 display times cover the range 1.4 seconds to 35 seconds in increments of 1.4 seconds.

When Z occurs the display time is determined by the manual setting of a single digit thumbwheel switch located on the front panel of the graphics control module. Switch position '0' causes the display to freeze indefinitely and positions '1' through to '9' increment the display time in 1.4 second steps.

(2) TYPE OF DISPLAY

A single numerical in the range 1 to 3 is required.

'1' selects the single channel display mode for any of the eight available channels.

'2' selects the cyclic display mode which enables any combination of the channels to be displayed in sequence for the predetermined display time.

'3' selects the multi display mode which enables any combination of the channels to be displayed simultaneously.

(3) CHANNELS FOR DISPLAY

A block of eight upper case letters in the range A to H with optional NULLS (octal 000) is required.

The letters identify the channels to be displayed and the nulls substitute for channels that are withheld from display.

An alphabetical sequence must be followed such that the block starts with either an A or a O and ends with either an H or a O. For single channel displays only one letter and seven nulls should appear in the block, but by default the leading letter in the block is selected. Valid data are always accepted and stored for any of the eight channels irrespective of the selected display status.

(4) STYLE

A single numeral in the range 0 to 2 is required.

'0' selects a PLOT file display where coordinates and vectors are derived, from a users PLOT file by a DECsystem-10 program called DISTEK. The PLOT file if sent to a DECsystem-10 plotter would duplicate the display as a hard copy. On completion of a PLOT file display the graphics control program waits for a MODE string.

'1' indicates that the data points on each display are not to be joined.

'2' indicates that consecutively entered points to each displayed channel are to be joined by straight lines. This facility is available for both single and cyclic displays but is not available in the multi channel display.

An example of a valid MODE string is:

↑R: B2ABODOOGH2↑T

Where ↑R is control R

↑T is control T

In this example, channels ABDG and H would be displayed in cyclic order with the data points associated with each channel joined by straight lines. The display time of each channel is set for 2.8 seconds.

In the cyclic display mode the recycle time for a repeat display of a given channel is dependent upon the number of channels selected for display, the content of each display and the number of screen erases involved.

$$\text{RECYCLE TIME} = \text{No. of channels in cyclic display} \times (\text{ERASE TIME} + \text{WRITE TIME} + \text{DISPLAY TIME})$$

Typically, each screen erase takes 750 milliseecs.,
each screen display of scaled coordinates takes 750 m sec.
to draw and may be displayed for up to 35 seconds unless
the indefinite freeze has been selected.

In the above example five channels (A, B, D, G and H) are selected which gives a recycle time of about 21.5 seconds.

3.2.2 Axis

The AXIS string consists of four blocks as shown in Table 3.

(1) ALLOCATED CHANNEL BLOCK

A single upper case letter in the range A to H is required to identify the channel allocated to the string.

(2) AXIS SCALE VALUES BLOCK

A total of 16 binary words, each of 8 bits (00000000 to 11111111) which corresponds to a decimal range of 0 to 255 referenced to the bottom left corner of the display screen. The 16 binary words have the following functions when grouped in 8 pairs of X, Y data values.

First pair: axis intersect coordinate.

Second pair: max. end point value of X and Y axis.

Third pair: min. end point value of X and Y axis.

Fourth pair: coordinate of leading X title character.

Fifth pair: coordinate of leading Y title character.

Sixth pair: spacing value for X and Y grids.

Seventh pair: scale numbers assigned to the X and Y grids nearest the axis intersect.

Eighth pair: increment value used to determine the scale numbers for remaining X and Y grids.

Usually the seventh and eighth pairs of numerals are identical except when an off-scale intersect is specified.

Signs are not required since the control program algorithm automatically inserts negative signs at X grids which are to the left of the intersect and at Y grids which are below the intersect.

(3) X AXIS TITLE BLOCK

Any combination of the 64 character set provided by the character generator is allowed except a comma, which is used to split the string between the X and Y titles.

(4) Y AXIS TITLE BLOCK

As for the X AXIS TITLE BLOCK and again no comma is allowed. A total of 20 ASCII characters must be assigned to the titles and filling with spaces may be required.

An example of a valid AXIS string is:

↑RLC (12 binary words usually nonprintable) 2525ALPHA DEG, CLIFT 10* - 3↑R

The string is assigned to the C channel with the X axis scaled in increments of ± 2 and the Y axis scaled in increments of ± 5 . The X title of 9 characters is ALPHA DEG and the Y title of 11 characters is CLIF* 10 - 3.

3.2.3 Dot

The contents of the three DOT string blocks are:

(1) ALLOCATED CHANNEL

A single upper case letter in the range A to H is required to identify the channel allocated to the string.

(2) SYMBOL

An ASCII character to specify the symbol required to be displayed at the datum point. Every datum point therefore has an associated symbol and where data points are being joined by straight lines, a "back track without joining" facility is activated by adding octal 200 to the ASCII symbol code. This causes back tracked data to be displayed by the specified symbol without line joining.

Removal of the octal 200 off-set from symbol codes of subsequent data points causes the line joining to recommence from the last datum point displayed before the symbol off-set was introduced.

(3) SCALED COORDINATES

Two 8 bit binary words give an X, Y range of 0 to 255 decimal units to position the symbol.

An example of a valid DOT string is:

↑R 00 H (2 binary words usually nonprintable characters) ↑T

This string assigns data to the H channel and the datum point is displayed as a plus (+) symbol.

3.2.4 Clear

A predefined CLEAR string clears the graphics display system by erasing the screen of the storage display unit and initialising the data store addresses.

An example of a valid CLEAR string is:

↑R 00 0 ↑T

Where 0 is octal 000 (NULL)

3.2.5 Text

A TEXT string consists of two blocks.

(1) COORDINATE OF LEADING CHARACTER

Two 8 bit binary words giving a 0 to 255 decimal range for positioning the start of the text.

(2) ALPHANUMERIC MESSAGE

Any combination of the 64 character ASCII set provided by the character generator up to a maximum of 376 characters. Text is displayed from left to right. A line feed causes a downward increment in the position of following text and a carriage return positions the next character to the originally specified X value of the leading character.

An example of a valid TEXT string is:

↑RSH (2 binary words usually nonprintable) (1 to 376 ASCII characters) ↑T.

Since text normally starts near the top left hand side of the screen the 2 binary words would normally have decimal values approximating 10,250. Text size is currently fixed for a character height of 3 mm to suit AXIS titles and scales but could be varied with a change in the EPROM control program.

3.2.6 PLOT file

The data string contains pairs of ASCII characters which, when selectively combined, provide the break points for straight lines to form the display. There is no limit on the length of the data string. Details are given in Section 4.3.3.

3.2.7 Wipe

Similar to CLEAR (Section 3.2.4) except that data store addresses are not initialised and therefore data held in the semiconductor memory of the graphics display system are retrievable after the screen of the storage display unit is erased.

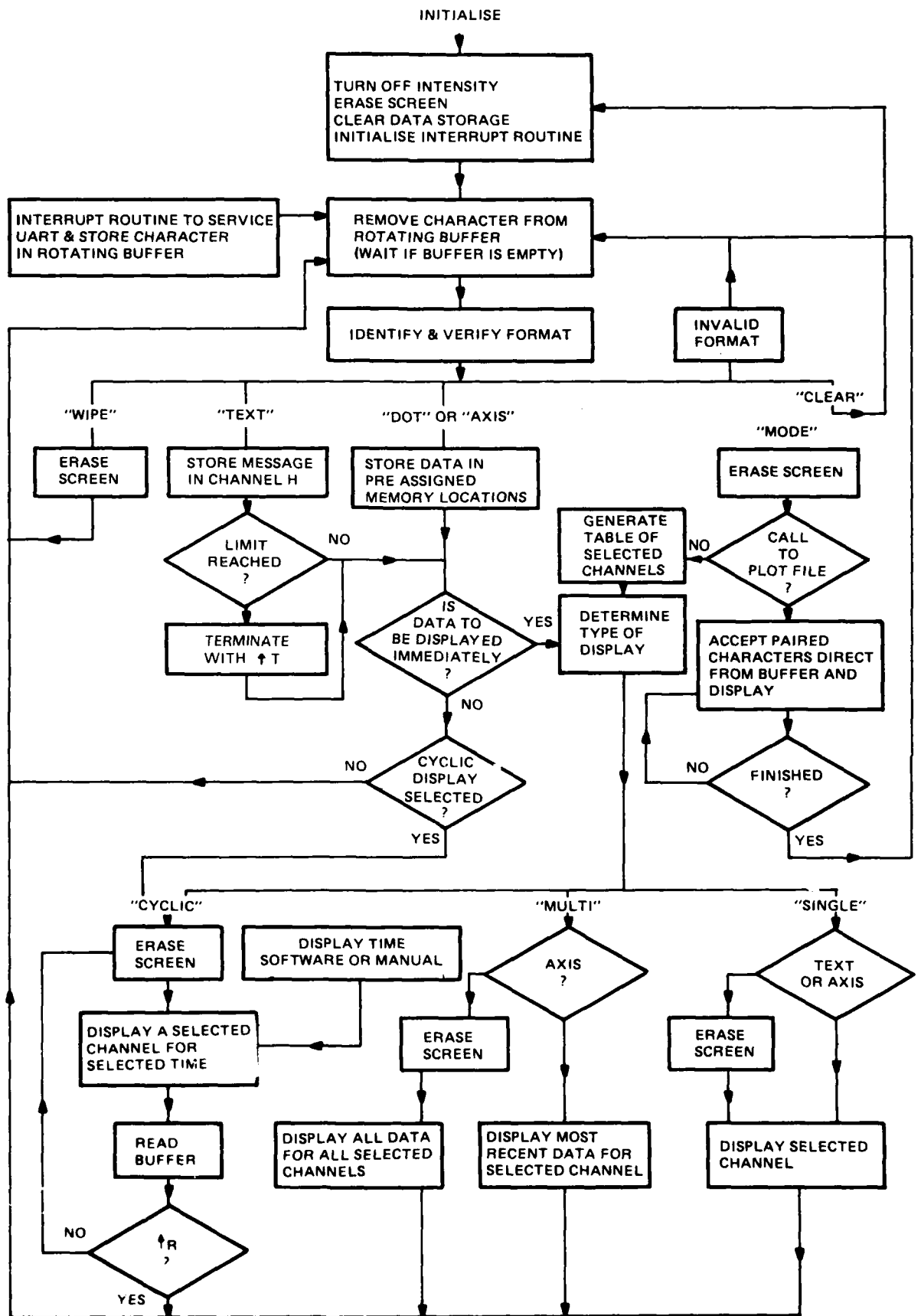

FIG. 4 SIMPLIFIED FLOW DIAGRAM FOR CONTROL PROGRAM

$C_D E = -2$

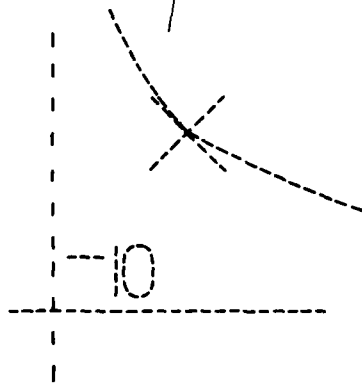
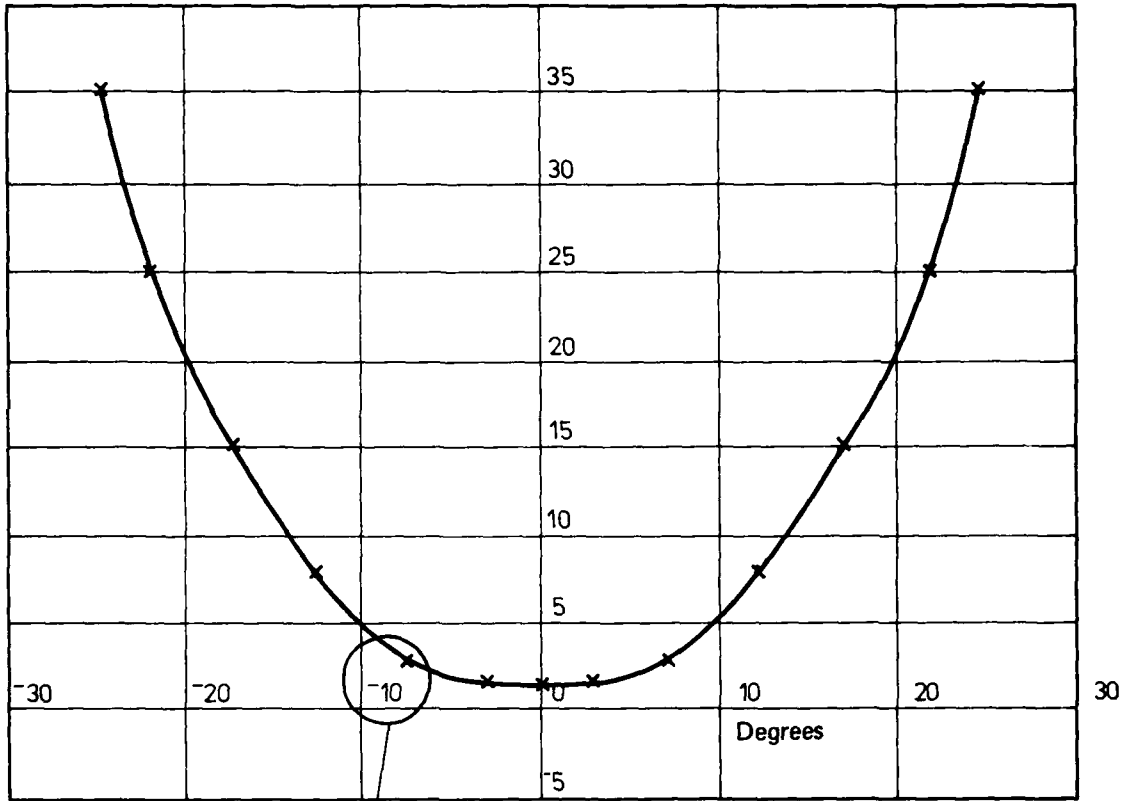

FIG. 5 SCALED CO-ORDINATES WITH DATA POINT SYMBOLS JOINED BY STRAIGHT LINES

An example of a valid WIPE string is:

↑RS0 ↑T

Where 0 is an ASCII NULL (octal 000)

4. SOFTWARE

4.1 Control Program

The control program is in two parts. The main program fits into 1024 (1K) EPROM locations and the support program which contains interrupt service routine, buffer storage control and line vector programs resides in an additional 365 EPROM locations.

The control program uses about 200 locations of the available 256 base page RAM. For reasons given in Section 5.2 a split base page of 128 EPROM (0FF80 to 0FFFF) and 128 RAM (00000 to 0007F) was not used.

A simplified flow diagram of the control program is shown in Figure 4 which is described in Section 4.2.3.

4.2 Main Program

Periodically, the main program reads characters from the circular buffer store (Section 4.3.2) and searches for a control R. In a cyclic display, the search occurs at regular intervals throughout the duration of the DISPLAY TIME. For other types of displays (single and multi channel) the search occurs when the control program has completed as much of the specified display as practical and is waiting for further data.

Once a control R character is found, the control program assumes that the start of a valid string has been detected and disengages from all operations, except UART interrupts, to service the string. Should the string fail a series of checks, the control program does not return from where it disengaged but determines if a MODE command is stored in memory. If this command is located then data that exists in RAM for the channel(s) specified are displayed, otherwise the program returns to a control R search loop of the buffer. No displays will be produced until a valid MODE string is received but valid data strings will be properly stored.

The character which follows the control R identifies the string and determines the subsequent verification procedure. Selected contents of valid strings are placed in preassigned areas of the RAM (Table 1). Care is taken to prevent an invalid string from overwriting previously stored data.

4.2.1 Display

The main program displays a scaled co-ordinate axis (Fig. 5) in the following sequence.

- (a) Data for the selected channel are unpacked from an assigned storage area of RAM.
- (b) If required the storage display screen is erased.
- (c) The unpacked data determines the display parameters and the X-Y axes are displayed as two straight lines at right angles to each other but not necessarily intersecting.

The axes are drawn as closely spaced dots by incrementing a low order bit of the D-A converter.
- (d) Vertical grid lines are then generated and appear to sweep from the extreme left hand end of the X axis. These lines, which are later scaled, are drawn with more widely spaced dots than that used for the main axes.
- (e) Similarly, to complete the grid pattern, horizontal lines appear in an incremental sweep from the extreme bottom of the Y axis.
- (f) The hardware character generator provides text titles for the X and then for the Y axis in locations specified in the AXIS string.

- (g) The grid lines are then scaled with the X axis scale values automatically positioned to the right of each vertical grid line and slightly above the X axis.

The Y axis scale values are then positioned slightly above each horizontal grid line and to the right of the Y axis.

Negative signs are automatically inserted by the program which senses scale values each side of the axis intersect.

- (h) Data, if available, are then superimposed on the scaled coordinate display as symbols which may or not be joined.

Typical displays are shown in Figures 6 and 7.

4.2.2 Program speed

Text is written at about 100 characters/second and scaled displays require about $\frac{3}{4}$ second to complete. A full string of text could take $3\frac{1}{2}$ seconds to write and a multi channel display of 8 scaled coordinate graphs may require up to 6 seconds of continuous writing on the storage screen.

The buffer, which has a capacity to store up to 59 characters without overflow, is not accessed for character removal while the spot is actually writing on the screen. In lieu of transmission pauses the following design options could be implemented to avoid the potential problem of buffer overflow.

- (1) Decrease the time needed to complete text and displays.
- (2) Assign more memory to the buffer.
- (3) Arrange for the main program to service the buffer more often.
- (4) Halt the host computer automatically with a buffer full flag.

4.2.3 Logic description

The graphics control program in addition to responding to valid strings, which enables the host computer to control the graphics display system, also provides the following service functions.

- (1) A screen erase is always initiated following acceptance of a MODE string. This ensures that whatever combination of display is selected there will be no overlays.
- (2) A CLEAR string erases the screen of the storage display unit and also clears all data memory locations. This enables the main control program to be initialised from the host computer.

A screen erase only without initialisation of data is provided by the WIPE string or by retransmission of a MODE string.

- (3) The TEXT string is automatically terminated after 376 characters but the shortened text is available for display.

Because TEXT strings share a common memory area then only the most recent TEXT string is accessible for display.

- (4) Whenever an AXIS string is stored in memory, all previously stored data associated with the same channel, are automatically rendered inaccessible for further display. This action assumes that the previously stored data are unsuitable for display on the axes because of changes in scale values.
- (5) Whenever new data are received during a cyclic display the display sequence always pauses and restarts with the leading channel.
- (6) The software option to join data points with straight lines applies to single and cyclic displays but is automatically inhibited for multi channel displays. Memory restrictions

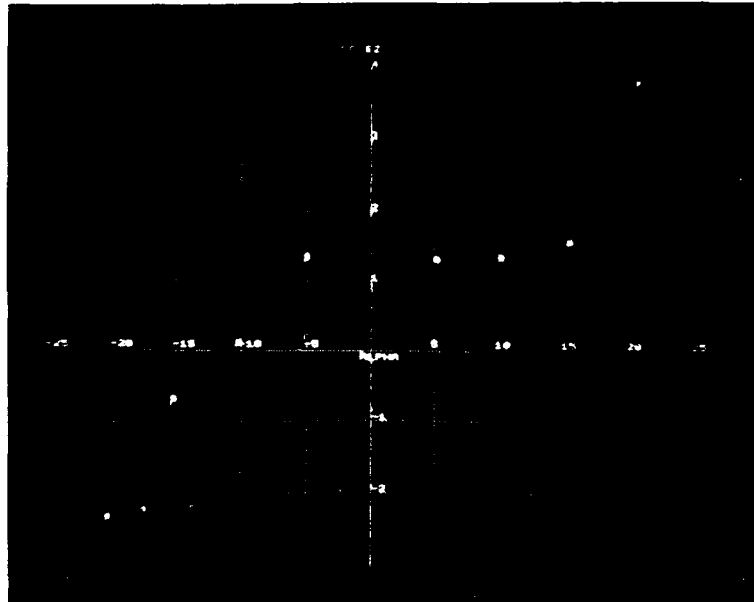

(a) Data points displayed by symbols

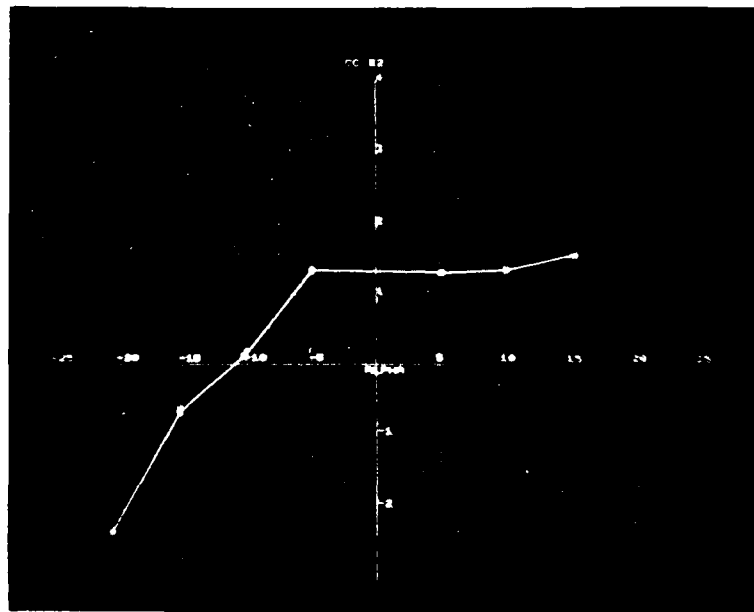

(b) Data points joined by straight lines

FIG. 6 SCREEN PHOTOGRAPHS OF A SINGLE CHANNEL DISPLAY

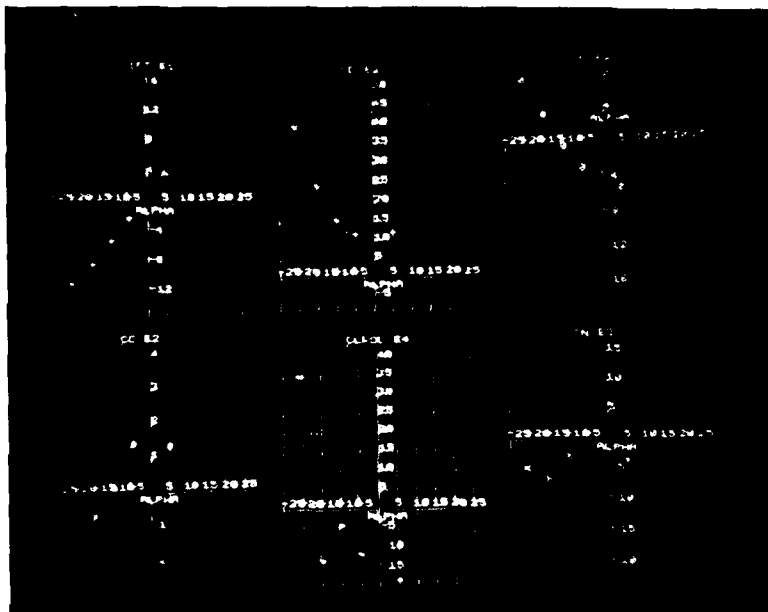

(a) Six channel display

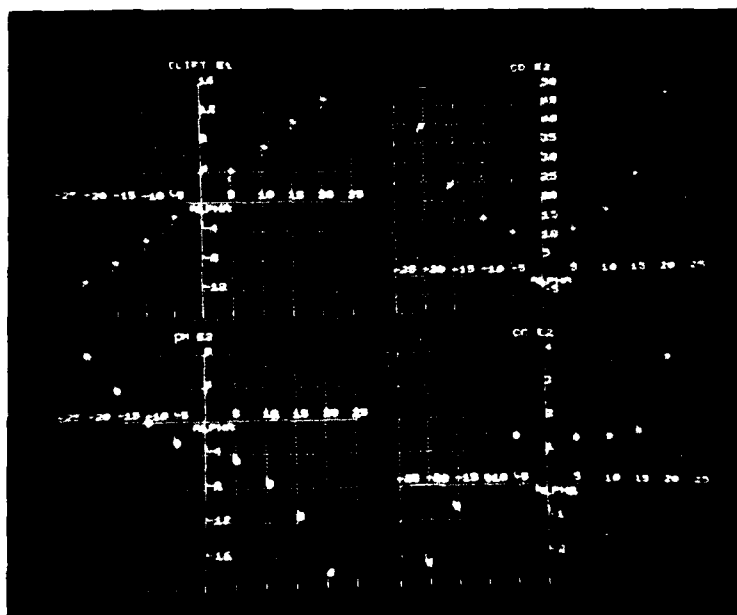

(b) Four channel display

FIG. 7 SCREEN PHOTOGRAPHS OF MULTI-CHANNEL DISPLAYS

prevent the control program from coping with multiple lines to randomly positioned data points when more than one channel is displayed simultaneously.

However, the control program for the larger screen version should be able to provide the multi channel line drawing option and also enable families of curves, instead of a single curve, to be displayed concurrently on a common display.

4.3 Support Program

4.3.1 UART service routine

Data and commands from the DECsystem-10 are received at the graphics display system in serial form by a UART interface, which is serviced through an interrupt service routine by the microprocessor which controls the storage display unit.

The interrupt routine clears a character from the UART whenever the UART signals that a complete character is available. The character is transferred to a circular buffer (Section 4.3.2) for temporary storage. This action is essentially invisible to the main program as the state of the processor (i.e. contents of registers and flags) at the instant of interrupt from the UART is saved and then restored immediately the interrupt routine is completed. This routine is completed within a few hundred microseconds which enables lengthy processes such as multi channel displays to be completed without visible interruption.

The speed of the interrupt routine basically sets the highest baud rate for transmission of characters to the UART interface. Other considerations were outlined in Section 4.2.2.

The service routine has been tested to 9600 baud in a different application but for the graphics display version being described the maximum overall speed is about 1200 baud. In operation with the data acquisition system, transmission is at 300 baud which is set by the Teletypewriter.

4.3.2 Buffer management routines

The circular buffer is managed by two routines. The first, named 'FILL', reads a character from the UART and enters the character into the circular buffer. The second, named 'REMOVE', takes a character from the buffer and makes it available to the main program for processing.

The routines are general purpose and suitable for many peripheral devices.

'FILL' is called by the interrupt routine (Section 4.3.1) and 'REMOVE' is called by the main program on an opportunity basis.

A buffer control block (BCB) of 5 memory locations, in addition to the locations allocated to the circular buffer, is used for management of the 'FILL' and 'REMOVE' routines.

The BCB locations are allocated in the following sequence:

'FIRST' contains the address of the start of the circular buffer.

'IN' contains the address of the next free location in the buffer.

'OUT' contains the address of the next character to be removed from the buffer which works on a first in first out (FIFO) principle.

'LIMIT' contains the last address of the buffer.

'FLAG' acts as an overflow counter and increments whenever 'FILL' has a character to store but the buffer is full.

The contents of the above locations provide the following information.

CIRCULAR BUFFER LENGTH is 'LIMIT'-'FIRST' + 1

BUFFER is empty when 'IN' = 'OUT'

or when 'IN' = 'LIMIT' and 'OUT' = 'FIRST'

The BCB is generally initialised with:

'FIRST' 'IN' 'OUT' and 'FLAG' = 0

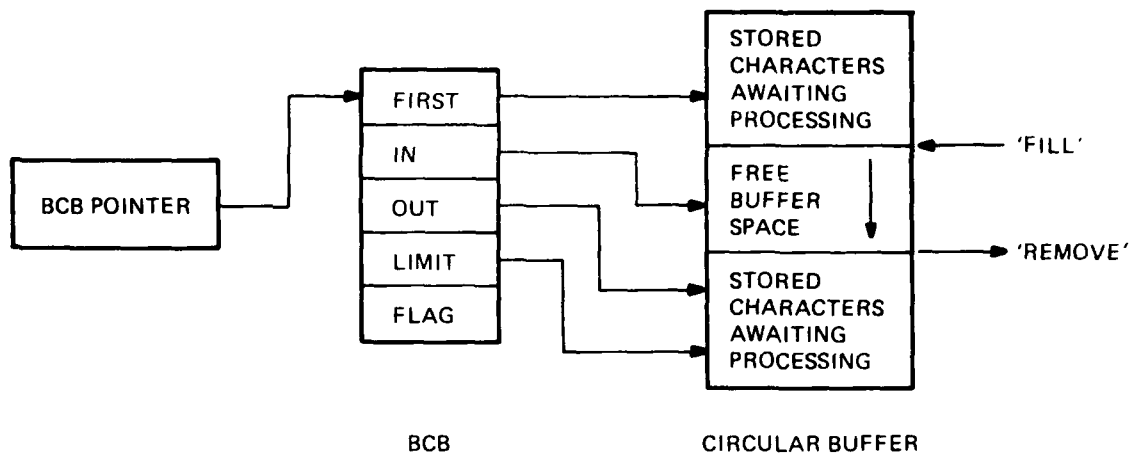

FIG. 8 BUFFER ARRANGEMENT

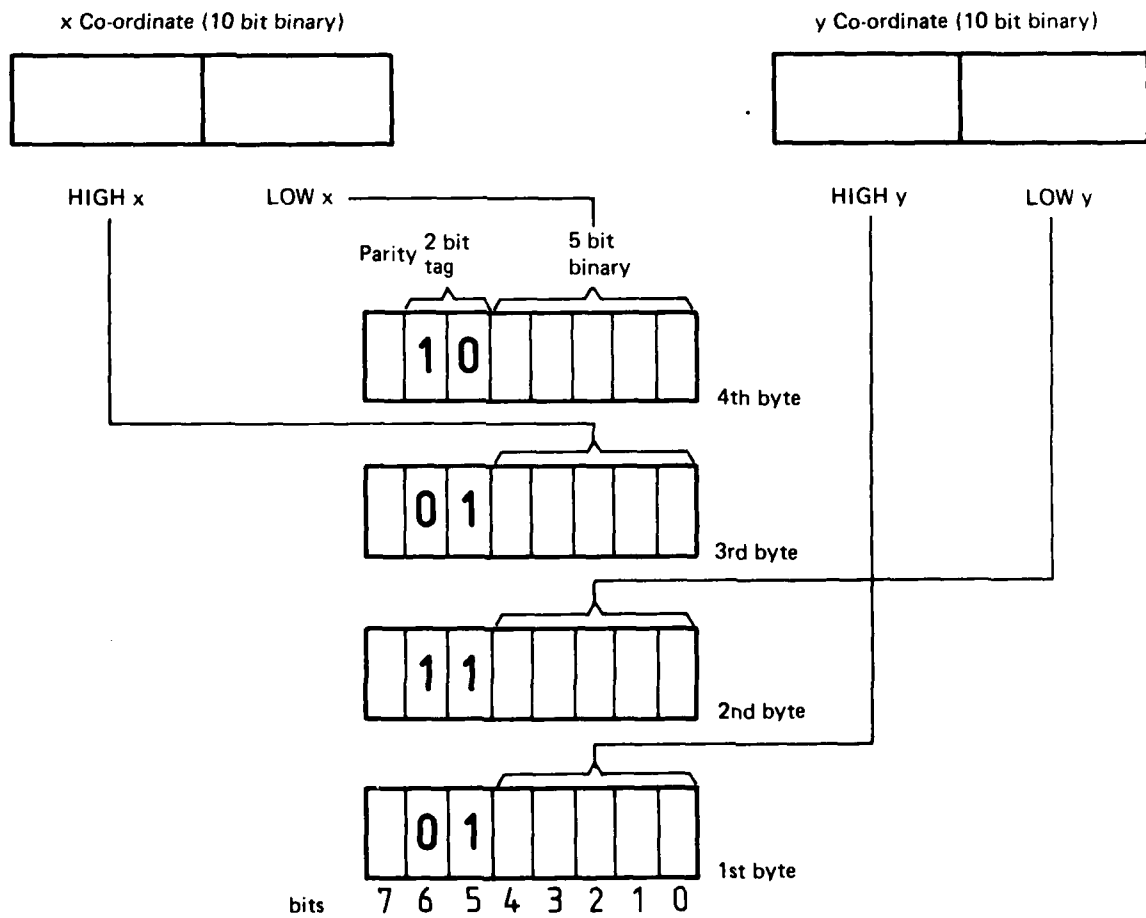

FIG. 9 BYTE COMBINATION FOR 10 BIT X, Y DATA

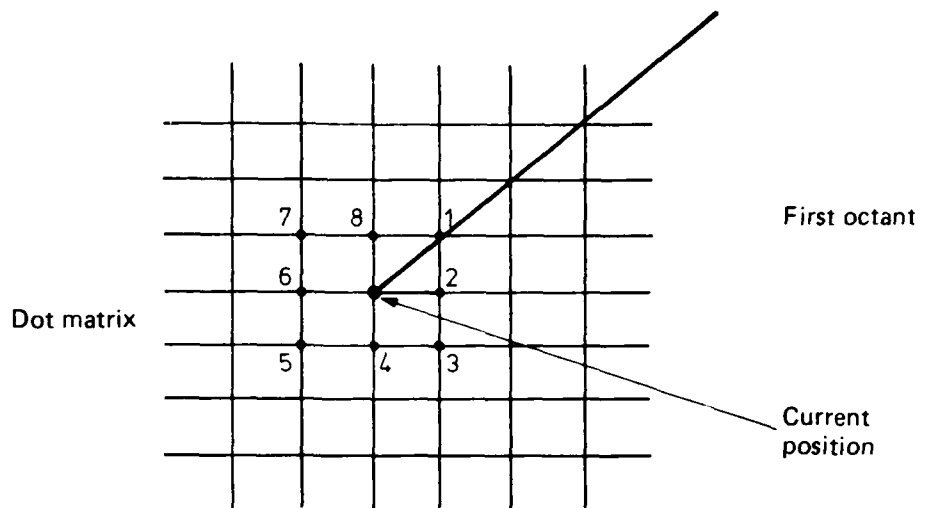

FIG. 10 POSSIBLE MOVES FROM CURRENT POSITION

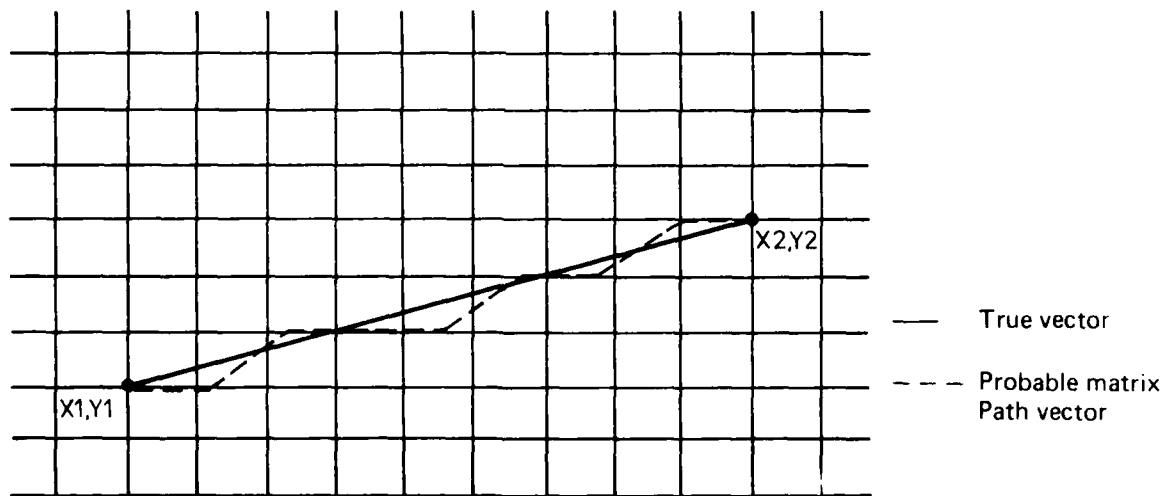

FIG. 11 VECTOR PATH BETWEEN TWO CO-ORDINATE POINTS $X_1 Y_1$, $X_2 Y_2$

In operation, characters commence to store at the location given by 'OUT' and continue (possibly around the buffer) to the location given by 'IN' - 1. Typical buffer management is shown in Figure 8.

4.3.3 Line drawing program

When the main program calls 'REMOVE', each accessed character is sensed for the start of a valid command or data string and all characters preceding a recognised start word are automatically discarded. The discarded characters may have been intended for the printer which shares the same line as the UART interface. Once a start word is detected the subsequent characters are removed sequentially from the buffer and checked until either a complete string is validated or the start word and associated characters are discarded as invalid. A valid string is immediately executed by the main program before 'REMOVE' is again called to search for the next start word.

Valid strings which start with a control R (octal 022) have been discussed in Section 3.2. However, strings which start with a GS (octal 035) cause the main program to immediately branch to the line drawing subroutine. This subroutine processes and interprets the string of following characters as a sequence of vectors until terminated by either a US (octal 037) or a carriage return (octal 015).

Co-ordinate information is contained in a four byte sequence of printable ASCII characters (Ref. 2). The sequence contains high and low order Y information and high low order X information in the above order.

Each byte (Fig. 9) contains 2 tag bits, 5 binary bits and a parity bit. The tag bits define the byte as high Y, low Y, high X or low X and the binary bits contribute to the co-ordinate value. Parity is ignored.

The first co-ordinate received after a GS, positions the beam of the storage display unit to a corresponding starting point which is not displayed (dark vector).

The next co-ordinate causes a visible vector to be drawn from the starting point to the new co-ordinate position. Further co-ordinates cause the visible vector to extend and join through the corresponding points. A dark vector is produced, to establish a new starting point on the display, whenever a GS is detected ahead of a co-ordinate. Once a starting point is established, only the low X and those bytes that change need be sent to the graphics display system.

4.3.4 Vector generation

The coordinate points which are decoded by the line drawing program (Section 4.3.3) are joined by software generated vectors. An algorithm selects the appropriate dots to be intensified from a 4096 by 4096 dot matrix produced by the 12 bit D-A converters that drive the storage display unit.

At each matrix point along the vector the algorithm selects from eight possible moves (Fig. 10) and intensifies appropriate neighbouring points to approximate the selected path (Fig. 11).

For a vector in the first octant, only two moves need to be considered:

- (1) in the $\cdot X$ direction. (predominant move).
- (2) one increment in both $\cdot X$ and $\cdot Y$ directions. (combined move).

The algorithm if written in PASCAL would be:

```
Procedure vector (X1, Y1, X2, Y2: integer); var dX, dY: 0.. 1023; a, b: integer;
begin
    dX := X2 - X1; dY := Y2 - Y1; a := dX div 2; b := dX;
repeat
    a := a + dY; if a >= dX then begin a := a - dX; combined move;
```

```
end
```

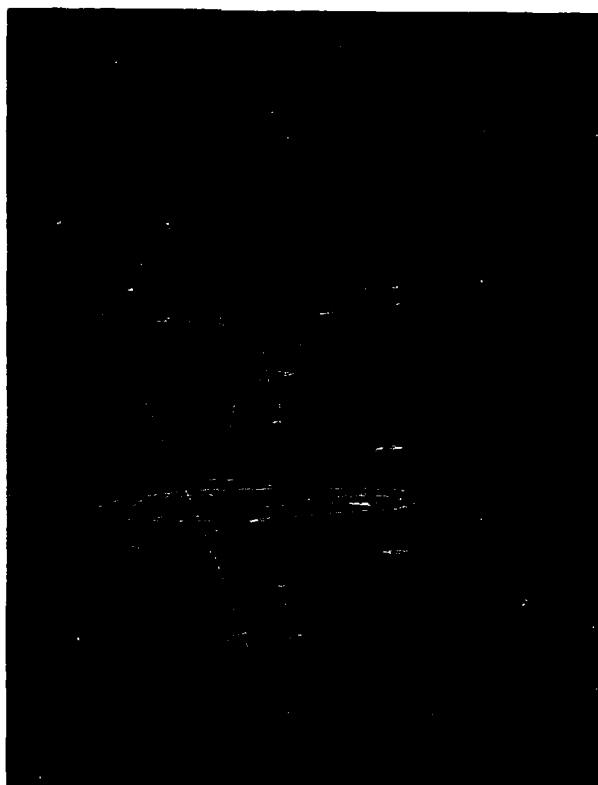

12(a) General purpose display

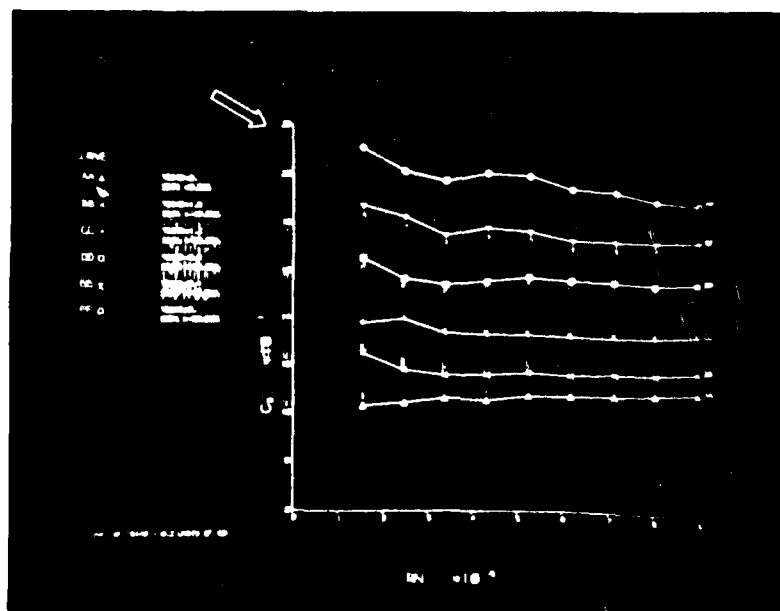

12(b) Family of curves

FIG. 12 SCREEN PHOTOGRAPHS OF "PLOT" FILES

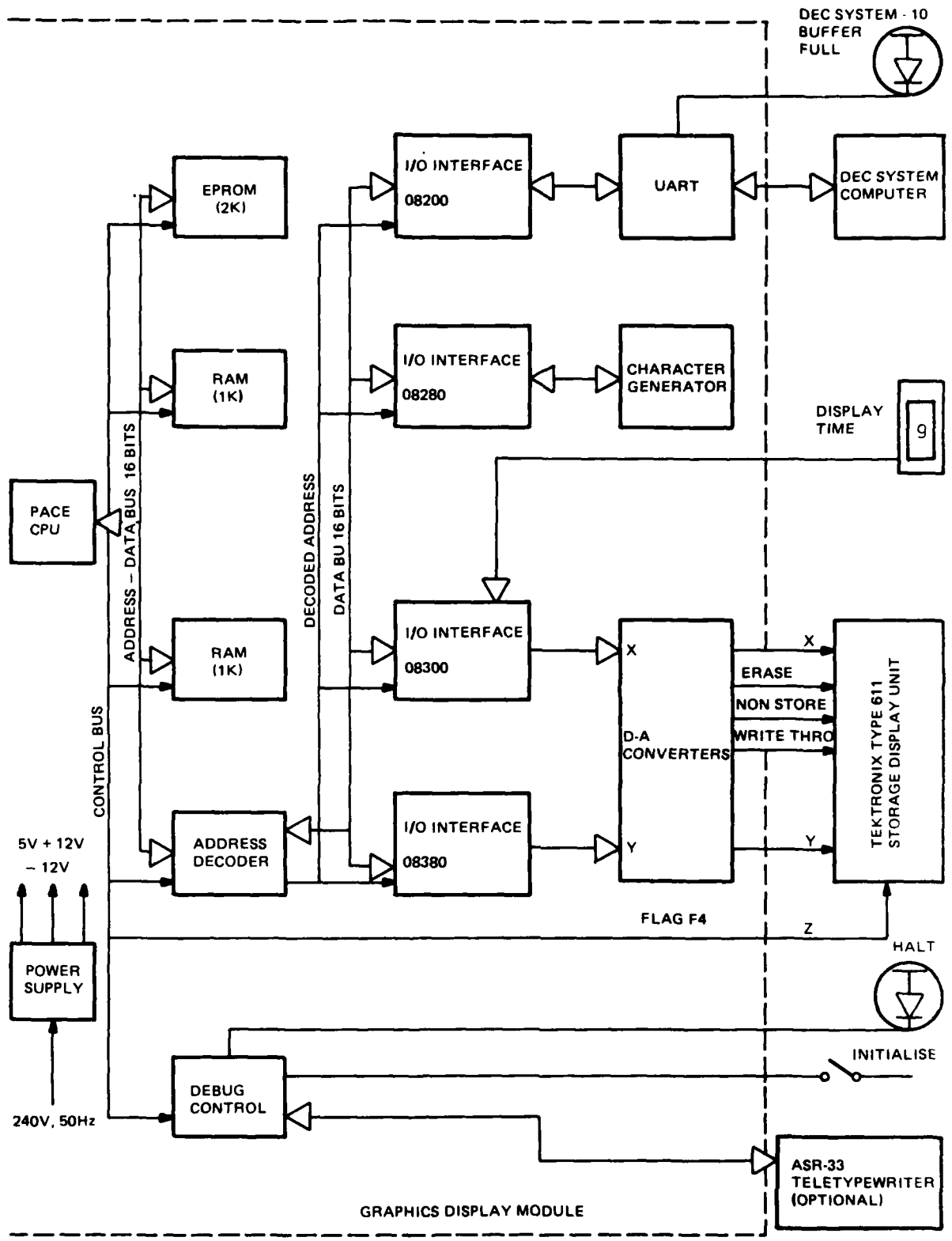

FIG. 13 INTERCONNECTIONS TO THE GRAPHICS DISPLAY MODULE

```

else predominate move; b: = b - 1
until b = 0
end (* vector *).

```

For other octants the algorithm needs to take into account the signs of the increments and the fact that the predominant movement and combined movement may be in other directions (Fig. 12).

4.3.5 Debug program

The graphics display system uses all the base page as RAM whereas the DEBUG program normally available for use with PACE application cards requires that the base page be split between RAM and ROM. The DEBUG program was modified for relocation to 0FE00 - 0FFFF and a power-on initialisation code added. The modified version was written into a pair of MM5204 Q EPROM packages (Ref. 3).

At power-on, initialisation causes the first instruction to be fetched from memory location 0FFFF (Section 5.2) instead of from 00000 as provided for by the original DEBUG program.

The DEBUG code associated with the fetch is:

```

      · = 0FFFF - 1
0FFFE · word BEGIN
0FFFF  JMP @. -1.

```

The address allocated for the indirect jump is 0FFFE and so execution transfers to the start of the modified DEBUG program given a symbolic address BEGIN.

The DEBUG program also senses for the presence of a Teletypewriter which, if detected, allows the DEBUG program to be controlled by Teletypewriter keyboard. Otherwise a jump from DEBUG to the main graphics control program occurs, which is the normal operation.

The following keyboard commands enable the memory content and functions of the graphics display system to be interrogated.

- H HELP; lists a brief description of the following commands.
- A ALTER; changes the content of a memory (RAM) location.
- B BINARY; loaded (Absolute); loads a binary program from paper tape.
- T TYPE; 8 words/line (1 word is 4 Hexadecimal characters).
- X TYPE; 1 word/line.
- G GO; allows a program to be executed.

5. HARDWARE

5.1 Card Set

The graphics display module contains the following set of printed circuit cards interconnected as shown in Figure 13.

- Central Processing Unit (CPU) card.
- 2 off 1K by 16 bit RAM cards.
- 2K by 16 bit EPROM card.
- Character generator card.
- UART interface card.
- DEBUG control card.
- 2 off 12 bit D-A converter cards.
- Input/Output interface and address decoder cards.
- Power supply card.

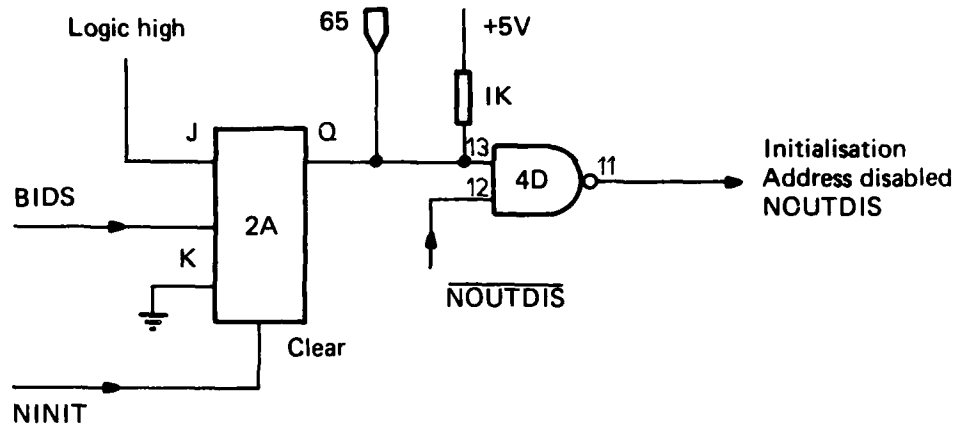

FIG. 14 MODIFICATION TO CPU CARD FOR INITIALISATION TO OFFF

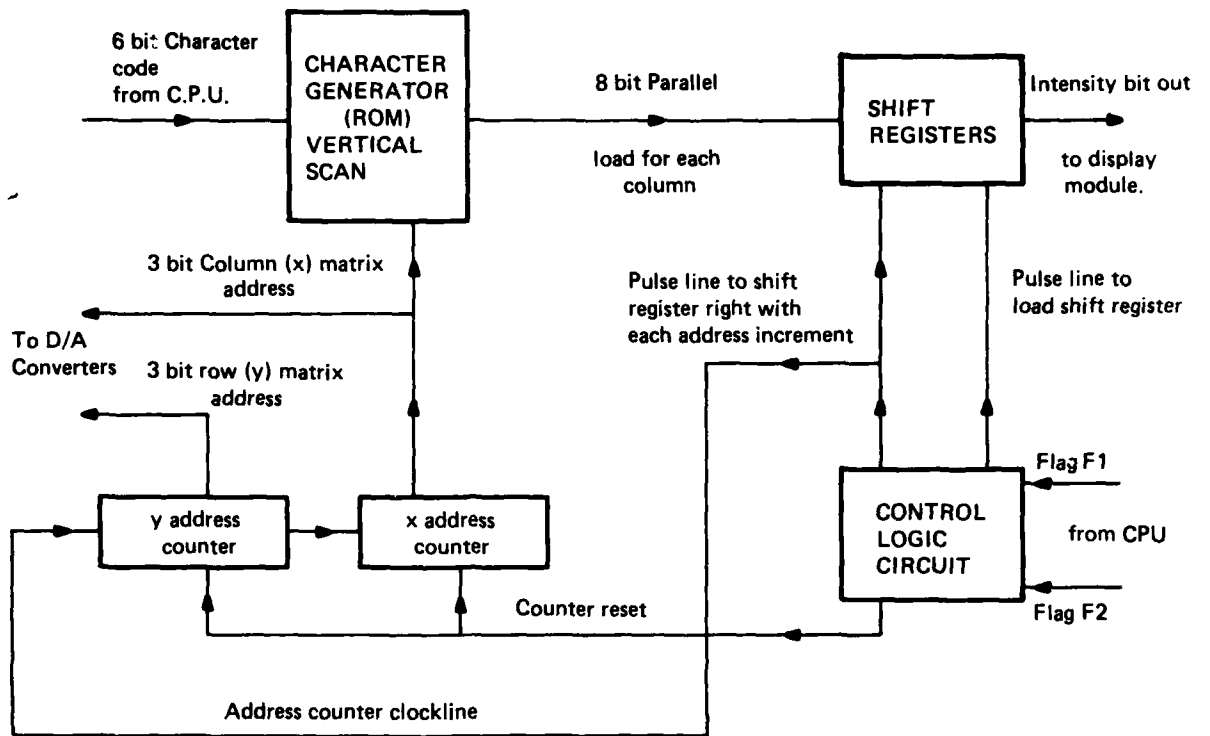

FIG. 15 CHARACTER GENERATOR CARD CONTROL DETAILS

The CPU, RAM and EPROM cards were obtained commercially while the remainder of the set are in-house cards.

5.2 Central Processing Unit

The commercial application card (CPU) and DEBUG program are intended for split base page addressing with half of the base page located between 00000 and 0007F and allocated to 128 locations of ROM. The other half of the base page spans the memory address range 0FFFF to 0FF80 and is allocated to 128 locations of RAM.

On initialisation, the CPU application card would output the address 00000 to fetch the first instruction from ROM which is usually a 'JMP' to the start of the users program.

However, the graphics display system was developed using a PACER development system, which normally operates without a split base page by allocating 256 locations of RAM to the address range 00000 to 000FF.

For many applications split base page addressing has advantages but for this graphics system, access to a full base page of RAM was highly desirable. Base page storage from the circular buffer for string validation and for command storage enabled many fetch and execute instructions to be simpler and faster than for a split base page arrangement.

Modification of the CPU application card was accomplished by grounding the 'BPS' pin on the CPU chip, to select 'no Base Page Split', and utilising the unused half of a dual flip-flop (74107 package 2A, Fig. 14) on the CPU card. Without the flip-flop modification, initialisation would address 00000 for the first instruction, but this address is in the range allocated to RAM: which is a volatile storage media and therefore unsuitable for storage of an automatic restart program instruction.

The flip-flop clears with the initialising signal (NINIT) and allows the Q output to hold the NOUTDIS line low which prevents the CPU from initialising to address 00000.

On the first read data strobe (BIDS) following the first address, the flip-flop is triggered to the set position to enable the NOUTDIS line and allow the CPU normal use of the bus. However, while the bus is disabled the initialisation address actually becomes 0FFFF, because of the presence of pull-up resistors which were added to all 16 bus lines. Thus the first fetch is from ROM which spans the range 0F800 to 0FFFF.

5.3 1K RAM Card

Two 1K RAM cards are used and together span the address range 0000 to 007FF with the leading 256 memory locations, between the addresses 00000 and 0007F, assigned to base page. The remaining memory is used for data storage as detailed in Table 1.

5.4 2K EPROM Card

The main control program for the graphics display system is contained in the memory address range 0F800 to 0FBFF with the modified DEBUG program residing in the range 0FE00 to 0FFFF. Support routines occupy the memory locations between 0FC00 and 0FDFF.

5.5 Character Generator Card

The character generator (Fig. 15) is designed around a MM5241 vertical scan 3072 bit static ROM which is factory programmed with a 64 character ASCII set. A six bit latched addressed word is required for character selection from the ROM and six sequential addresses to a group of three low order address lines allows six 8 bit parallel words to be read from the ROM.

Each of the 48 bits is used to control the intensity line of the storage display unit. In conjunction with 3 bit X and Y address words, this produces an 8 row by 6 column dot matrix display of the selected character.

The 3 bit sequential column addressing of the ROM is produced by the X binary counter which advances one state on every eighth clock pulse of the Y binary counter. Clock pulses to the Y counter are controlled by the CPU, as flag F1, and the states of both binary counters and the corresponding bit from the ROM are read by the CPU after every pulse of flag F1. The 3 bit X and Y words, generated by the binary counters, are shifted left or right in a CPU register to increase or decrease the size of the character matrix before being applied to the D-A converters which deflect the beam of the storage display unit.

The hardware of the character generator is controlled by software for the following action. Flag F2 is pulsed to reset both the row and column binary counters and clear the control logic circuit. Once cleared, the first pulse of flag F1 is gated to load the shift registers with the first block of 8 bits which are read from the ROM and represent a column of intensity bits.

Subsequent pulses of flag F1 are gated to produce 'shift right' control of the shift registers and advance the column counter which generates the Y output address word of the character matrix. Every eighth pulse of flag F1 advances the column counter through the Y address range and the ninth pulse of flag F1 triggers a one-shot monostable multivibrator in the control logic circuit. This single pulse initiates a reload of the shift registers on the following flag F1 pulse. The action is repeated as the row binary counter continues to be pulsed to address sequentially the ROM and generate the X address word of the matrix. The action is completed on the sixth operation.

5.6 UART Interface Card

The UART interface card contains a general purpose circuit arrangement which is able to receive and transmit digital serial data to standard RS-232C at up to 9600 baud. A line driver (Type 1488) and a line receiver (Type 1489) are used to interface between TTL and RS-232C logic levels. Provision exists on the card to decode X-0N (octal 021) and X-0FF (octal 023) for transmission control (Section 4.2.2).

In the present version of the graphics display system only the receive section of the UART package (Type MM 5303) is used and operation is at either 300 or 1200 baud which is selectable by a dual clock circuit set to 16 times the baud rate.

5.7 DEBUG Control Card

The modified DEBUG program (Section 4.3.5) allows control of the CPU to be transferred from the graphics control program to an operator. Transfer occurs automatically when a Teletypewriter is sensed as being connected to the module. Timing also automatically adjusts for operation at 110 baud.

Under the DEBUG program flag F1 pulses serialised data to the operators terminal and the paper tape punch is controlled by flag F2. In single step operation the level '0' interrupt is used. An 8 bit shift register is cleared by a pulse from flag F4 and the NBADS pulses, generated by the CPU, clock the shift register whenever a program instruction is fetched. This gates a trigger pulse to a monostable multivibrator which causes the DEBUG program to print out the content of the program counter.

5.8 D-A Converter Cards

Two 12 bit D-A converters (Type DA 1200 CD) provide the analogue signals for the X and Y deflection of the Tektronix 611 storage display unit. Full scale analogue output of +10 volts is obtained with a digital input of 0000 and zero output corresponds to an input data word of 0FFF. A resistor network attenuates the analogue output to match the +1 volt full scale X and Y deflection sensitivity of the storage display unit.

Three inverting amplifiers are also included on the card as buffers, between the Input/Output interface and the storage display unit, for the remote erase, write through and non-store lines.

5.9 Input/Output Interface and Address Decoder Cards

The PACE CPU is arranged with the 16 bit address and the 16 bit data bus's multiplexed to the same CPU pins. Demultiplexing of the common address/data bus is accomplished by address and data latches.

The address bus is demultiplexed by a 16 bit TRI-STATE latch (IPC-16A-518) which is clocked on the positive edge of the NBCLK strobe when the NBADS line is low. The latched address lines are then decoded to provide unique addresses for each peripheral. Thus the peripherals of the microprocessor, e.g. UART, D-A converters and character generator, are selected as though at specified memory addresses.

Likewise, the bidirectional data bus is demultiplexed by two 8 bit bidirectional TRI-STATE latches (IPC-16A-503) which are selectively clocked by the positive edge of the NBCLK strobe.

For a 'LOAD' instruction to a peripheral the addressed input data latch receives an input data strobe (BIDS) and for a 'STORE' instruction the addressed output data latch receives an output data strobe (BODS). Simultaneously, the BIDS or the BODS strobe two groups of four TRI-STATE quad D flip-flops (Type 74173) to separate the bidirectional data bus, at the CPU, into either a 16 line input or a 16 line output data port.

Output data latches only are required for the D-A converter cards which are unidirectional but the character generator card requires both input and output data latches.

5.10 Power Supply Card

Three supply rails are required to power the graphics display system these supplies are:

- 5 volts @ 5 amperes
- 12 volts @ 1 ampere
- 12 volts @ 1 ampere

All three regulated supplies are mounted on a single printed circuit card and protected against current overload by thermal shutdown facilities within each of the integrated circuit voltage regulators.

The +5 volt supply is derived from a LM309K integrated circuit regulator and a 2N3055 transistor. The dual 12 volt supply is designed around two LM317T integrated circuit regulator packages.

5.11 Construction

The microprocessor card set is housed in a frame fitted with printed circuit connectors and card guides. The frame, which is of general purpose construction, fits within a module of the Low Speed Wind Tunnel Data Acquisition System console. Slides allow the module to be withdrawn from the console, rotated and locked in position to give easy access to the plug-in card set and rear connectors.

Positioned on top of the console, with a downward facing slope of about 25 degrees, is the storage display unit. The screen is above eye level of a seated operator and easily viewed by standing observers. A sheet of non-reflective picture glass has been fitted to the screen face to reduce reflections at the expense of a noticeable, but acceptable, reduction in clarity of displays.

For operator convenience the front panel controls are minimal with all external connections at the rear of the module.

Front panel controls are:

- (1) Mains switch with indicator.
- (2) Initialisation switch. (Initialises the CPU to start program execution at EPROM address 0FFFF).
- (3) Halt indicator. (The light emitting diode glows whenever the CPU halts program execution; a fault condition for the graphics program).

- (4) Display time selector switch. (Allows the operator to dial the display time when in the cyclic display mode).

Rear connections are:

- (1) Mains power inlet and fuse.
- (2) Connection to the storage display unit.
- (3) Connection to the DECsystem-10 computer. (Line shared by the Data Acquisition System).
- (4) Connection for a Teletypewriter Model ASR33.

6. OPERATING INSTRUCTIONS

- (1) Switch 'MAINS' power to graphics control module.
- (2) Switch 'MAINS' power to storage display unit.
- (3) Depress 'INITIALISE' switch located on the front panel of the graphics control module and ensure that on release that the red 'HALT' light extinguishes.
- (4) Ensure that no bright spot is visible on the display screen and press the 'ERASE' switch located on the lower right hand side of the display unit.
- (5) Execute host computer program that drives the display system.

Note The storage display unit automatically reduces the display intensity after about 1½ minutes of static display to minimise permanent burn damage to the phosphor. The display reappears in response to a valid string, or by pressing the 'VIEW' switch located at the lower right side of the display unit.

ACKNOWLEDGMENTS

The authors are grateful to I. M. Kerton for carrying out much of the hardware construction and to B. W. B. Shaw who devised and wrote the DECsystem-10 programs. Such programs were able to assess user reaction to the quick look facilities of the evaluation version of the graphics display system when operated on-line under both simulated and actual operational conditions.

REFERENCES

1. Sear, W. F. L., Sutton, C. W., and Harvey, J. F. A versatile data acquisition system. ARL Report (in preparation).
2. Tektronix, Inc. Reference manual for Tektronix 4010/4010-1 computer display terminal.
3. Sutton, C. W. A microprocessor controlled PROM programmer. ARL Aero Technical Memo No. 313.

DISTRIBUTION

Copy No.

AUSTRALIA

Department of Defence

Central Office

Chief Defence Scientist	1
Deputy Chief Defence Scientist	2
Superintendent, Science and Technology Programs	3
Australian Defence Scientific and Technical Representative (UK)	—
Counsellor, Defence Science	—
Joint Intelligence Organisation	4
Defence Library	5
Document Exchange Centre, D.I.S.B.	6-22

Aeronautical Research Laboratories

Chief Superintendent	23
Library	24
Superintendent — Aerodynamics Division	25
Divisional File — Aerodynamics	26
Authors: C. W. Sutton	27
J. F. Harvey	28
G. A. Cleave	29
Inst. Group: G. P. Rundle	30-31
Low Speed Wind Tunnel Group:	
T. Trimble	32
D. Lemaire	33
B. W. B. Shaw	34
Computer Centre: I. L. K. McNaughton	35

Materials Research Laboratories

Library	36
---------	----

Defence Research Centre, Salisbury

Library	37
---------	----

Navy Office

Naval Scientific Adviser	38
--------------------------	----

Army Office

Army Scientific Adviser	39
-------------------------	----

Air Force Office

Aircraft Research and Development Unit, Scientific Flight Group	40
Air Force Scientific Adviser	41

Department of Productivity

Government Aircraft Factories

Manager	42
Library	43

Department of Science and the Environment

Bureau of Meteorology, Publications Officer	44
---	----

Department of Transport		
Secretary		45
Library		46
Statutory, State Authorities and Industry		
BHP, Melbourne Research Laboratories		47
Universities and Colleges		
James Cook	Library	48
Latrobe	Library	49
Melbourne	Engineering Library	50
Monash	Library	51
R.M.I.T.	Library	52
INDIA		
Defence Ministry, Aero Development Establishment, Library		53
Indian Institute of Technology, Library		54
ISRAEL		
Technion — Israel Institute of Technology, Professor J. Singer		55
NETHERLANDS		
Central Org. for Applied Science Research TNO, Library		56
SWEDEN		
Chalmers Institute of Technology, Library		57
UNITED KINGDOM		
Royal Aircraft Establishment:		
Farnborough, Library		58
Bedford, Library		59
Royal Armament Research and Development Establishment		60
Spares		61-70

DATE
ILME