

AD-A096 608 NAVAL SURFACE WEAPONS CENTER SILVER SPRING MD  
THE ROBOTIC DERIVETER - SYSTEMS CONCEPT.(U)  
SEP 80 J M VRANISH  
UNCLASSIFIED NSWC/TR-80-353

F/G 6/4

NL

10/1  
8/22/81

END
DATE
FILED
4 11 81
DTIC

NSWC TR 80-353

LEVEL II

(12)

AD A 096608

# THE ROBOTIC DERIVETER — SYSTEMS CONCEPT

BY JOHN M. VRANISH

ENGINEERING DEPARTMENT

2 SEPTEMBER 1980

Approved for public release, distribution unlimited.

DTIC  
S MAR 23 1981

A

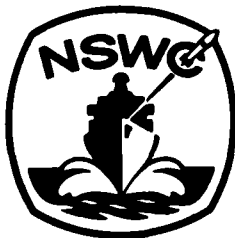

**NAVAL SURFACE WEAPONS CENTER**

Dahlgren, Virginia 22448 • Silver Spring, Maryland 20910

81 3 20 002

UNCLASSIFIED

SECURITY CLASSIFICATION OF THIS PAGE (When Data Entered)

REPORT DOCUMENTATION PAGE		READ INSTRUCTIONS BEFORE COMPLETING FORM
1. REPORT NUMBER (14) NSWC/TR-80-353 ✓	2. GOVT ACCESSION NO. AD-A096608	3. RECIPIENT'S CATALOG NUMBER 608
4. TITLE (and Subtitle) (6) THE ROBOTIC DERIVETER - SYSTEMS CONCEPT		5. TYPE OF REPORT & PERIOD COVERED (9) Final Repts
7. AUTHOR(s) (10) John M. Vranish		6. PERFORMING ORG. REPORT NUMBER
9. PERFORMING ORGANIZATION NAME AND ADDRESS Naval Surface Weapons Center White Oak Silver Spring, Maryland 20910		8. CONTRACT OR GRANT NUMBER(s)
11. CONTROLLING OFFICE NAME AND ADDRESS		10. PROGRAM ELEMENT, PROJECT, TASK AREA & WORK UNIT NUMBERS (12) 35 / (11) 2 Sep 80
14. MONITORING AGENCY NAME & ADDRESS (if different from Controlling Office)		12. REPORT DATE September 2, 1980
		13. NUMBER OF PAGES 33
		15. SECURITY CLASS. (of this report) UNCLASSIFIED
		15a. DECLASSIFICATION/DOWNGRADING SCHEDULE
16. DISTRIBUTION STATEMENT (of this Report) Approved for public release; distribution unlimited		
17. DISTRIBUTION STATEMENT (of the abstract entered in Block 20, if different from Report)		
18. SUPPLEMENTARY NOTES		
19. KEY WORDS (Continue on reverse side if necessary and identify by block number) Robotic Deriveter                      Sensor Rivets                                      Turret Alignment Smart Tool Head                        Robotic Arm Microprocessor		
20. ABSTRACT (Continue on reverse side if necessary and identify by block number) The Robotic Deriveter has been awarded the top priority among the 45 Army, Air Force, and Navy submissions for the DOD Productivity Enhancement Investment Program and is slated for a \$1.4M 2-year development program commencing in FY 81. This paper is a technical description of the systems concept.		

DD FORM 1 JAN 73 1473

EDITION OF 1 NOV 65 IS OBSOLETE  
S/N 0102-LF-014-6601

UNCLASSIFIED

472563 all

SECURITY CLASSIFICATION OF THIS PAGE (When Data Entered)

UNCLASSIFIED

SECURITY CLASSIFICATION OF THIS PAGE (When Data Entered)

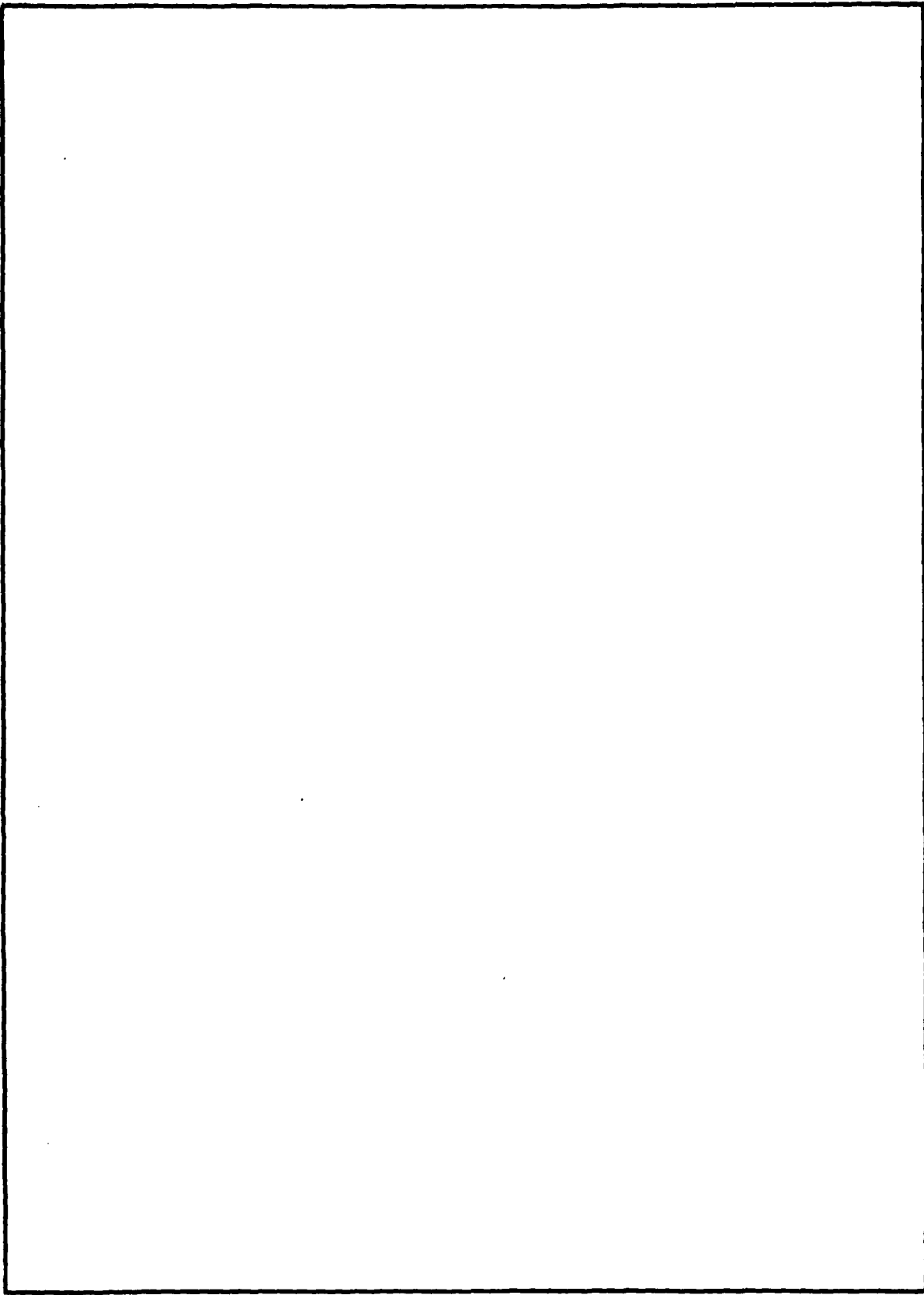

UNCLASSIFIED

SECURITY CLASSIFICATION OF THIS PAGE (When Data Entered)

FOREWORD

The Robotic Deriveter was originated by NSWC as a Productivity Enhancement Proposal to the Naval Air Rework Facility, North Island (NARF, NI). The proposal was submitted, in turn, to NAVAIR. In the course of the NAVAIR/DOD review process, the Deriveter Systems Concept received the number one priority for DOD in the FY-81 Productivity Enhancement Investment Program resulting in (a) projections of \$1.4M for a two year development program commencing in FY-81 and (b) widespread interest in the DOD, industrial and academic technical communities. This paper is a detailed systems outline designed to assist the \$1.4M development program and answer the technical and systems questions coming to NSWC.

*T. R. McKnight*

T. R. MCKNIGHT  
By direction

Reception for	
NSWC/NAVAIR	<input checked="" type="checkbox"/>
NSWC/T&B	<input type="checkbox"/>
NSWC/AS&D	<input type="checkbox"/>
Justification	
Distribution/	
Availability Codes	
Avail and/or	
Special	
A	

CONTENTS

	<u>Page</u>
I. Introduction.....	5
The Robotic Deriveter.....	5
Why the Navy Needs a Robotic Deriveter.....	5
Cost Savings.....	7
II. How the Deriveter Works.....	7
The Basic Operation.....	7
Safety Features.....	8
Reliability and Cost Reduction Features.....	8
III. Technical Details.....	8
The Smart Tool Head.....	8
The Vehicle and Robotic Arm.....	23
Automatic Data Processing.....	28
IV. Summary.....	30

## ILLUSTRATIONS

<u>Figure</u>		<u>Page</u>
1	ROBOTIC DERIVETER SYSTEMS CONCEPTUALIZATION.....	6
2	SMART TOOL HEAD CONCEPTUALIZATION.....	9
3	DERIVETING PROCESS.....	11
4	EXAMPLE OF COMMON SENSE ARTIFICIAL INTELLIGENCE.....	12
5	OPTIONAL TURRET WITH 2 DRILLS. ....	14
6	DRILL DISPLACEMENT CAUSED BY ERROR IN ANGLE TO NORMAL.....	16
7	TURRET ALIGNMENT.....	17
8	THE AUTOSCAN I SENSOR SYSTEM - HAND PORTABLE VERSION.....	19
9	SENSOR HEAD DETAIL.....	20
10	POSSIBLE SIMPLE SENSOR MODIFICATION TO FACILITATE AUTOMATED SEARCH.....	21
11	TOOL HEAD FRAME.....	22
12	ROBOT ARM PROGRAMMING AND AUTOMATED TOOL HEAD FRAME POSITIONING.....	24
13	"MODIFIED LEAD AND TEACH" VALVES WHICH THE ROBOT KEYS ON.....	25
14	ROBOTIC ARM DEGREES OF FREEDOM.....	27
15	MICROPROCESSOR FUNCTIONAL RELATIONSHIPS.....	29
16	COMMAND AND CONTROL CONSOLE CONCEPTUALIZATION.....	31

I. INTRODUCTION

A. THE ROBOTIC DERIVETER

The Robotic Deriveter is a mobile robotic system (figure 1) consisting of three major subsystems:

1. Smart tool head
2. Vehicle and robotic arm
3. Command and control system.

This system is designed to accomplish automated removal of rivets from Navy aircraft; it features the ability to:

- o automatically remove 70% to 80% of the aircraft's rivets
- o seek out and find rivets using a combination of "common sense" artificial intelligence to determine the rivet pattern and a precision sensor system for rivet center determination
- o recognize and remove rivets of differing sizes
- o remove rivets from small or irregularly-shaped wing panels and panel sections
- o cause no unacceptable damage to aircraft skin panels or their supporting structural members
- o inspect, detect and identify cracks in panels or substructures in the vicinity of the rivet with or without rivet removal.

B. WHY THE NAVY NEEDS A ROBOTIC DERIVETER

During maintenance on Naval aircraft, it is often necessary to remove large sections of the skin for corrosion control (caused by salt spray), for implementing modifications and to get access to cables, wiring, fuel tanks, etc. Often an entire wing skin must be removed.

The skin panels may have an overall area in excess of 1,000 sq ft. These panels vary in size and shape and are attached to the frame by up to 4,000 rivets for a single upper wing surface in an E-2 or C-2 aircraft. Furthermore, these rivets are not all of the same size. The current method of rivet removal is manual drilling and punching of each rivet. This is tedious, slow work and exposes the worker to potential danger from flying metal chips, and possible injury due to slipping or drill-bit shattering.

Drilling out the rivets requires concentration, skill, coordination, and strength (to ensure a straight bore down the center of the rivet shaft). The repetitiveness and physical/mental effort involved in this process leads to rapid fatigue,

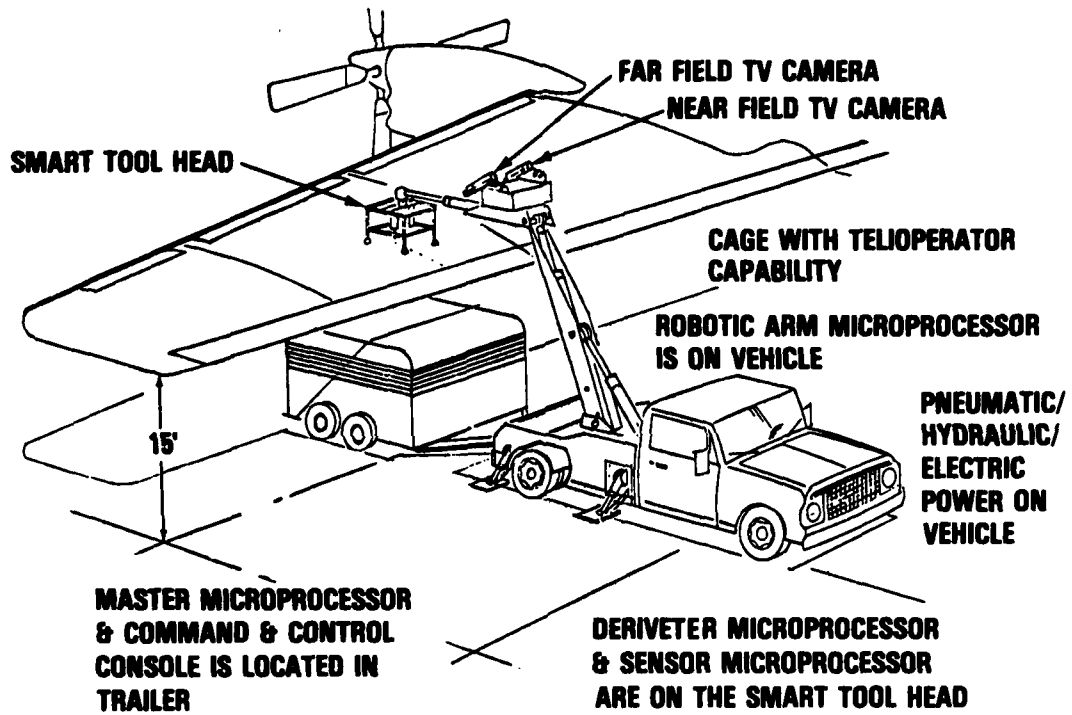

FIGURE 1 ROBOTIC DERIVETER SYSTEMS CONCEPTUALIZATION

boredom, and shortened periods of continuous effort with the resultant adverse effect on morale and quality control. As a result it may take 2 to 3 months to get a single wing completely derivated. Such delays can be costly and critical for aircraft turnaround and availability.

C. COST SAVINGS. Navy projections are that rivets will be an important fastening device in Naval aircraft for years to come. The Department of Defense "Final Ranking Productivity Investment Fund Projects" for FY-81 indicates a \$10.0M return on investment (ROI) savings in the six (6) continental U.S. Naval Air Rework Facilities at the present work load.

## II. HOW THE DERIVETER WORKS

### A. BASIC OPERATION.

1. The operator drives the vehicle to the appropriate aircraft in the hangar.
2. The operator outlines the panels from which the rivets are to be removed by positioning the tool head frame four times (one on each corner), via teleoperator using TV monitors (see figure 1). With a near-field view and a far-field view, the rivets to be removed can be positively identified.
3. The operator then applies light mineral oil to the rivet heads for good ultrasonic sensor coupling. This can be done either by the operator standing in the boom bucket on the robotic arm (figure 1) or by a brush/sponge on the end of the robotic arm.
4. The operator then moves the tool head to the starting position and the automatic process begins.
5. The tool head frame is pressed firmly against the aircraft skin. A pressure monitor guards against too much pressure causing skin wrinkle.
6. The smart tool head removes the rivets within the 4-foot square area covered by the head.
  - a. The smart tool head sensor system locates the center of the first rivet to  $\pm .005$ " and determines the drilling depth. It also inspects for cracks around the rivet  $.030$ " long or greater.
  - b. The tool turret on the tool head positions a punch over the center of the rivet and indents a drilling starting position.
  - c. The tool turret positions the drill and drills to the depth of the rivet head. The punch is then repositioned over the rivet and the rivet punched out.

d. The head moves to the next rivet location and a. through c. are repeated. If the rivet is of a different diameter, the tool head can drill and "scrub out" the hole, or alternately switch to a second drill bit.

e. For the first few rivets, the system locates the rivets by raster scan search. Soon, the "common sense" artificial intelligence algorithm is able to figure out the rivet pattern and search time is cut down.

f. When all the rivets under the smart tool head are removed, the robot arm automatically moves the smart tool head and the process begins anew.

g. The vehicle is moved as necessary by the operator.

Estimated rate of rivet removal: 100-200 per hour. A hard copy report summarizing the day's activities can be generated at the control console printer. (Number of rivets removed, which ones have stress cracks around them, elapsed time, problem log, etc.)

#### B. SAFETY FEATURES.

1. Identification of substructure cracks .030" long or greater.
2. Prevention of damage to airframe substructures by limiting drilling depths.
3. Stops automatically upon indication of error.
4. Removal of operator from the drilling process.

#### C. RELIABILITY AND COST REDUCTION FEATURES.

1. Smart tool head uses sensor which is commercially available.
2. Robotic arm and vehicle use commercially available vehicle and power systems.
3. Command and control console uses commercially based microprocessor, software, smart terminal, printer, and teleoperator displays.

### III. TECHNICAL DETAILS

A. THE SMART TOOL HEAD. The operation of the smart tool head (Figure 2) begins with the microprocessor-driven X-Y-Z control mechanism conducting a raster scan search pattern with the eddy-current sensor to locate the rivet center. The rivet in the lower right hand portion of the aluminum tubing cage is the one which will be operated on first. Having located the rivet center (to  $\pm 0.005$ " accuracy) the sensor will begin its ultrasonic sensing process. The total sensing process

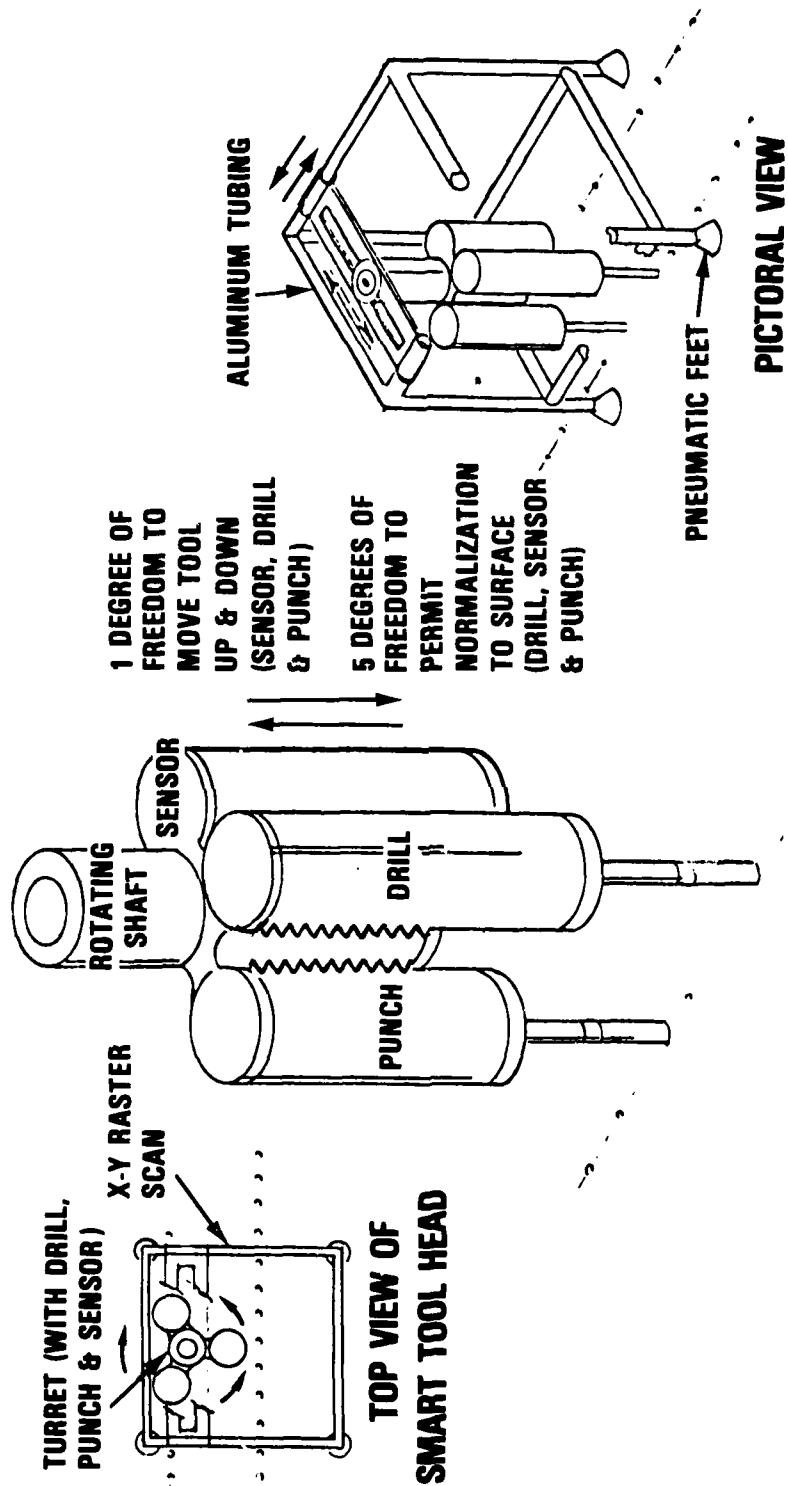

FIGURE 2 SMART TOOL HEAD CONCEPTUALIZATION

(eddy current and ultrasonic) will yield the rivet center, the normal to the skin surface, the diameter of the rivet shaft, the skin (and thus drilling) depth, and the presence or absence of cracks (.030" or greater) in the substructure.<sup>1</sup>

This information is fed into the smart tool head micro-processor and the turret reacts by swinging the punch over the top of the rivet center and indenting it. Following this, the appropriate undersized drill will be selected and the rivet will be drilled to the depth of the skin (to preclude damage to frame members) and punched out (see figure 3).

The smart tool head is now ready to locate the next rivet. Again, it begins a raster scan search with the eddy-current portion of the sensor and locates the center of the next rivet and the process begins again.

Common Sense Artificial Intelligence. After the smart tool head has removed 3 or 4 rivets, it begins to get a "feeling" for the pattern of the rivets and the spacing between them. It is now in a position to save search time by "figuring out" the pattern (figure 4). There are several methods to "figure out" the pattern, one of which might work as follows: the sensor begins in the lower right of the rivet pattern and works its way along the border of the pattern always checking one space inside the border (path [1], figure 4). (One space is the average distance between rivets.) As the turret (and sensor) follows this path it encounters a skew in the pattern (path [2]). It follows this skew until the skew ends in a rectilinear pattern. The turret then returns to the border and follows paths [3] and [4], removing rivets as it progresses. Thus, the vast majority of rivets will be removed while unnecessary search time is minimized.

Simple Rivet Patterns. Of course there are many instances where not all of the rivets in an area are to be removed. Perhaps a rectangle of 50 rivets in the Y direction and 20 rivets in the X direction is to be derivated. Simple typed instructions to the command and control portion of the system should be able to accomplish this.

---

<sup>1</sup>Characteristics of Ultrasonic Sensor Autoscan I discussed between author and Monty Rangy, Systems Research Laboratories, (under contract to USAF) 6/17/80

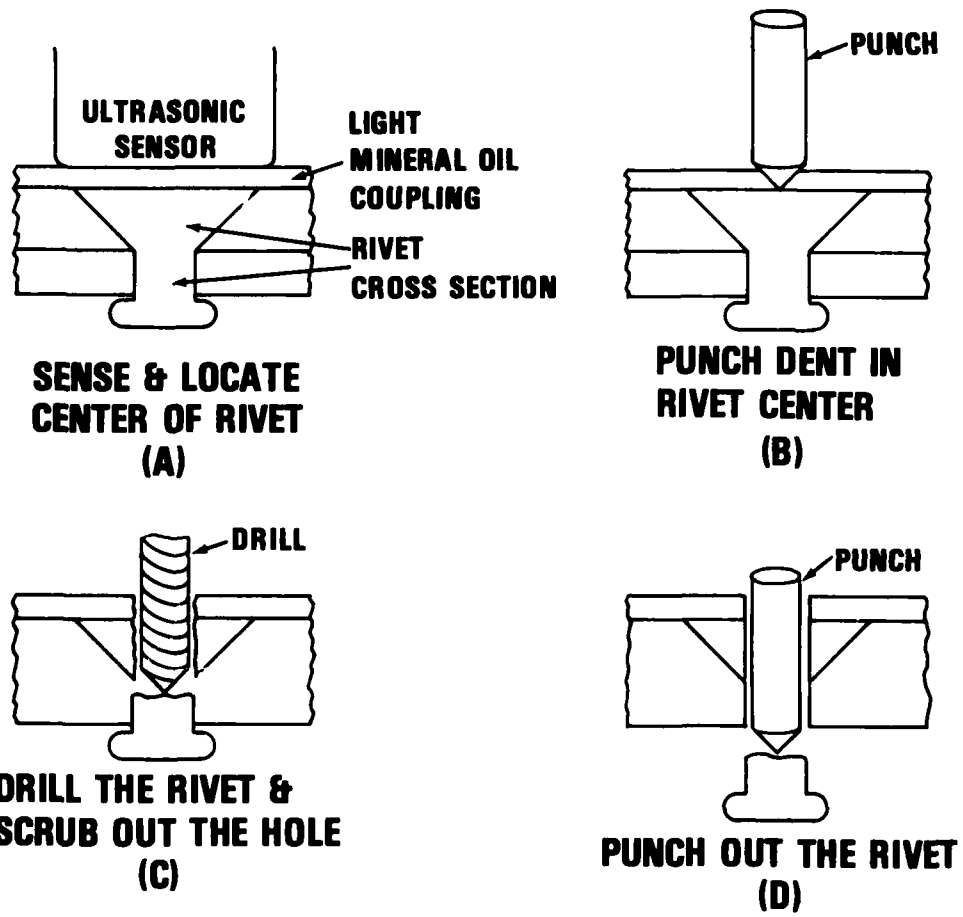
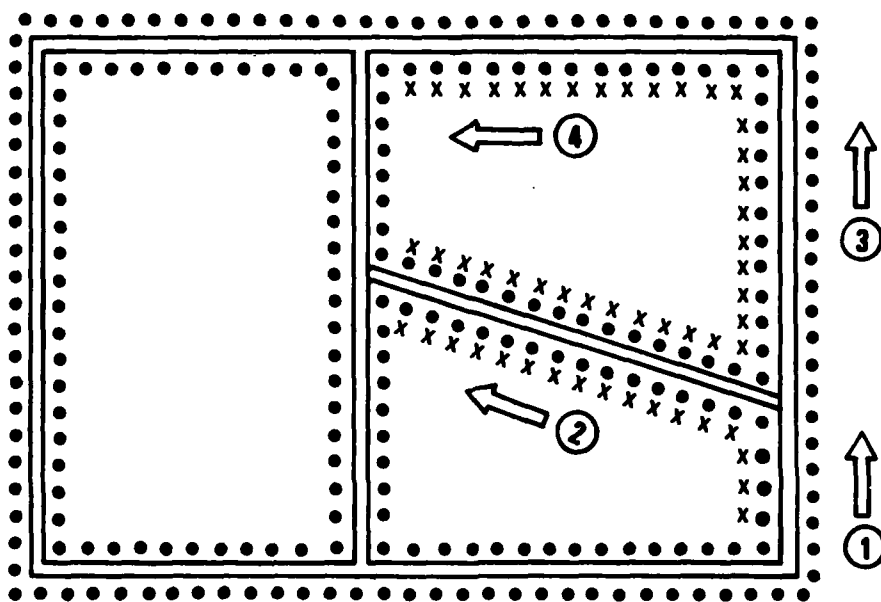

FIGURE 3 DERIVETING PROCESS



- REPRESENTS RIVET LOCATION
- X REPRESENTS SENSOR SEARCH WITH NO RIVET PRESENT

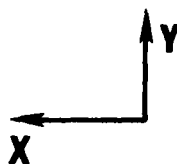

FIGURE 4 EXAMPLE OF COMMON SENSE ARTIFICIAL INTELLIGENCE

Punch and Drill Sizes. Rivet shaft diameters generally vary between  $3/16''$  and  $3/8''$  and a typical thickness for aircraft skin is  $3/16''$  (although it should be noted that aircraft skin thickness varies along the span of the wing). Thus, we must drill undersize, below  $3/16''$  diameter for the small rivets and  $3/8''$  diameter for the large rivets, and "scrub out" the excess metal with the drill. If we assume an absolute tensile strength of 37,500 psi for the aluminum alloy rivets and an impact force of 50 lbs for our punch,  $50 \text{ lbs}/37,500 \text{ psi}^2$  requires that the aluminum be drilled out so that only  $.00133 \text{ in}^2$  remains to be snapped off by the punch. Given the equation:

$$\pi \frac{D^2}{4} - \pi \frac{X^2}{4} = .00133 \text{ in}^2$$

where  $D$  = the diameter of the rivet stem and  $X$  = the diameter of the drill hole, for a  $3/16''$  diameter rivet ( $.188''$ ).  $X$  must  $\geq .183''$ , and for a  $3/8''$  diameter rivet ( $.375''$ )  $X$  must  $\geq .373''$ . Essentially the size of the drill equals the rivet diameter hole. Referring to figure 3, one can see that if the drilled hole is slightly oversized, no damage will be sustained to the substructure (as long as the drilling depth is controlled) and no appreciable damage will occur to the wing skin. (It should be noted that for most corrosion-driven deriveting operations, the removed skins are routinely replaced.) In cases where the drill is undersized for the rivet, the X-Y-Z raster scan and microprocessor should be able to "scrub out" the hole. The accuracy of the X-Y-Z scan should be conservatively on the order of  $.01''$  since it is stabilized on the aluminum tubing cage, and this accuracy should be sufficient when considered along with the fact that a slight amount of over-diameter drilling is not critical.

It is also possible to have an alternate design of the tool head turret using 2 drills (see figure 5). This may save a lot of "scrubbing out" time by using standard drill sizes close to the exact rivet diameter where more than one rivet size is involved and these rivet sizes are significantly different.

---

<sup>2</sup>p. 896 Metals Handbook, Vol 1. Properties and Selection of Metals, 8th Edit. American Society for Metals, Metals Park Ohio 1961.

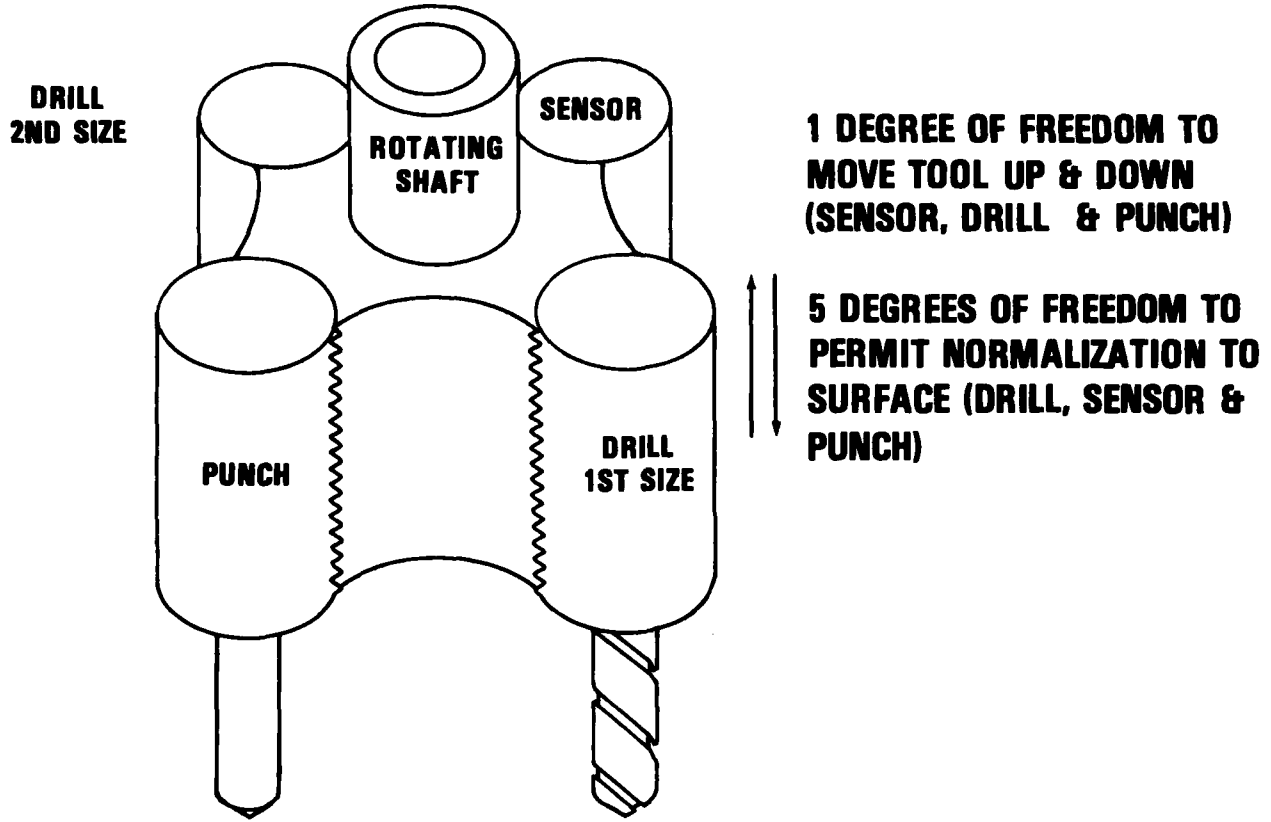

FIGURE 5 OPTIONAL TURRET WITH 2 DRILLS

Drill and Punch Alignment. With the curvature on aircraft wings and fuselages, drill and punch alignment is a consideration. With a required drill depth in the order of 3/16", angular errors in drill alignment are not particularly critical. In the course of using the ultrasonic sensor to examine the region around the rivet, the normal to the surface is found to about 1° accuracy leading to a displacement in the order of .00327" (figure 6).

The turret concept is inherently an accurate system in terms of alignment. Referring to figure 5, the center of the drills, sensor and punch can be made the same fixed radial distance from the turret axis, and the rotation done only in fixed, accurate clicks of 90° each. To align the sensor to the rivet normal, the entire turret axis can be aligned. Once this turret axis is aligned for the sensor, it can be left in place during the rest of the punching and drilling process. The only motion necessary will be the individual tools moving up and down to drill, punch or disengage. The tools can easily be calibrated in vertical alignment so that their individual vertical travel does not throw them off center (this could even be self-calibration by computer). Furthermore, the movement of the axis of the turret itself can easily be limited to linear and angular travel in X-Y only, again keeping things simple and accurate (see figure 7).

The Sensor. A key to the robotic deriveter is the sensor, the Autoscan I system developed by The Air Force Manufacturing Technology Program. A sensor system using both eddy currents and ultrasonics, the Autoscan I is specifically designed for examining rivets in aircraft. Its specifications are:

- o Flaw detectability - less than .030" radial depth (substructure cracks)
- o Material thickness range - .06 to .600"
- o Bolt diameter range - 3/16 to 3/8"
- o Center Accuracy -  $\pm .005$ "
- o Inspection rate field conditions - including set-up and calibration - 50 to 100 fasteners/hr. (This is for manual operation)<sup>3</sup>

---

<sup>3</sup>Letter from Frank M. Taylor, Manager, NDE Systems; Systems Research Laboratories, Inc. to author, 6/22/80.

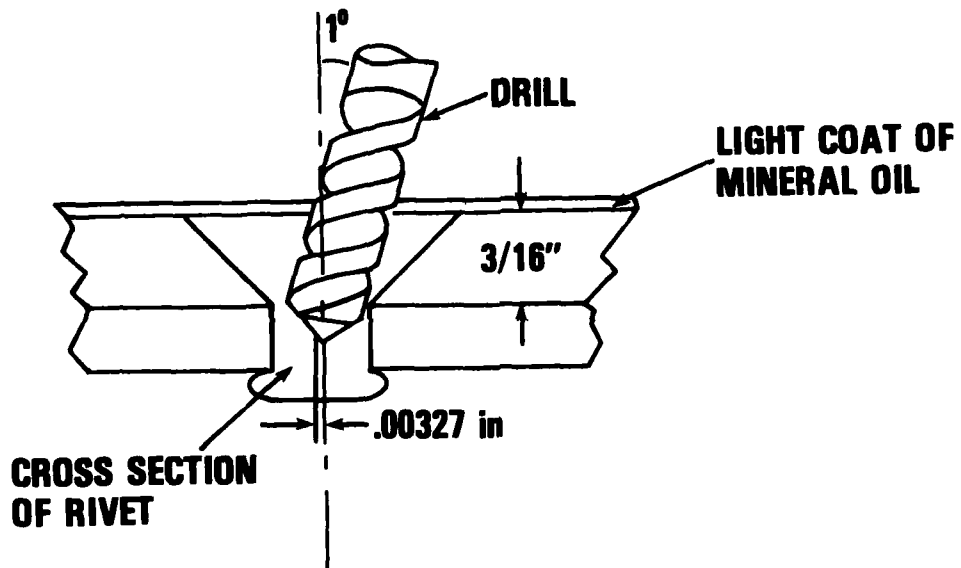
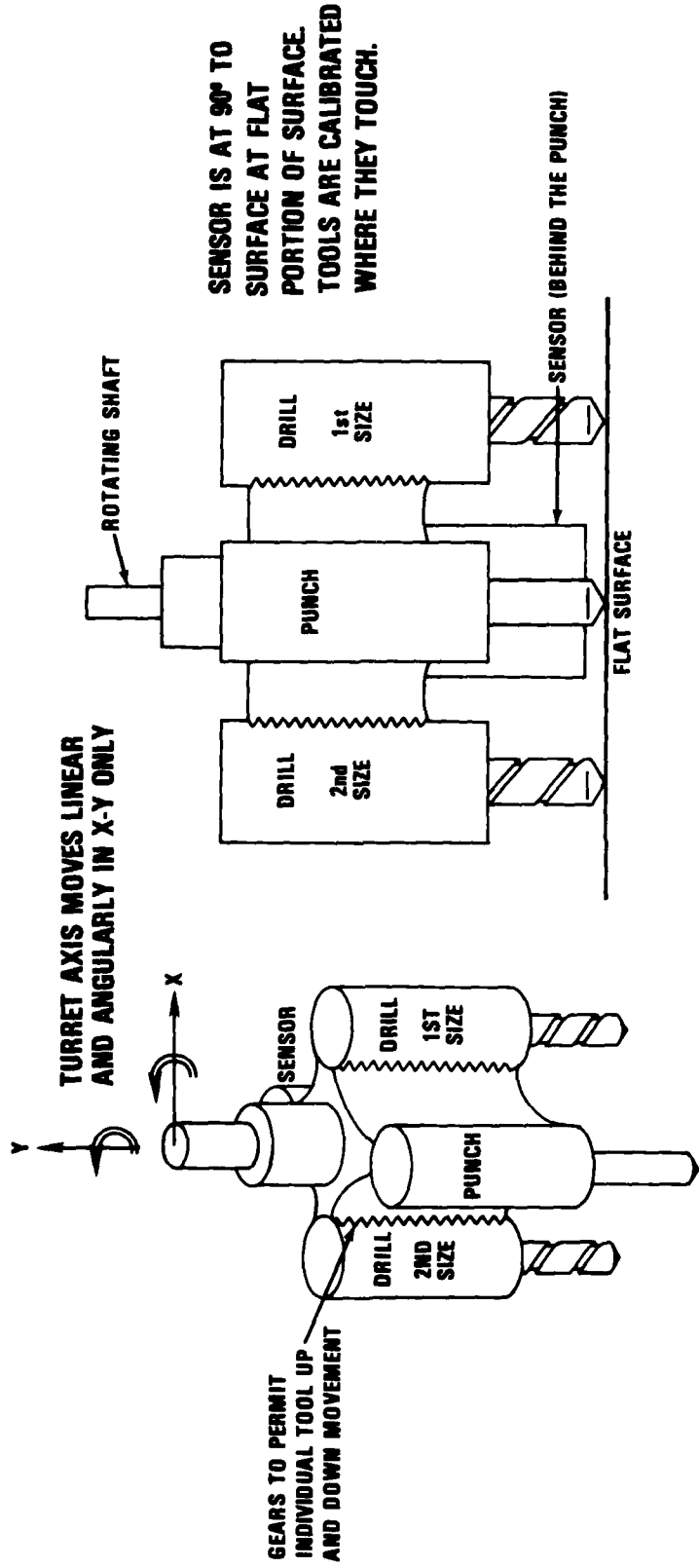

FIGURE 6 DRILL DISPLACEMENT CAUSED BY ERROR IN ANGLE TO NORMAL



TOOL & TURRET AXIS DEGREES OF FREEDOM (A) SELF CALIBRATION SCHEME (B)

FIGURE 7 TURRET ALIGNMENT

The Autoscan I sensor system (figure 8) consists of the sensor, a microprocessor and a display.

The head detail is shown in figure 9.

For use in the deriver, the Autoscan I must be modified to be more automated. Specifically, the logic functions currently assisting the operator in aligning the sensor normal to the center of the rivet at the correct standoff must be fed back into the smart tool microprocessor and the adjustments made automatically. Also, the sensor must be modified to aid in the automated search function. The eddy current probe inspects continuously as the turret goes through its search pattern. It sees only a few thousandths of an inch into the skin so it can locate rivet head centers without being confused by cracks and substructures inside the airframe. To do this, the eddy current probe must have a standoff of .030". At the same time, the ultrasonic probes must not touch during the search pattern, but must make contact during the inspection of the rivet and the airframe substructure surrounding it. This requires a modification of the sensor which should be straight forward. One method might be as shown in figure 10.

Software modifications have to be made to the smart tool head microprocessor to facilitate the steps shown in figure 10. Still another modification must be made to automatically flag a crack in the structure, rather than have the operator pick it up on the display as is done now. This requires a "thresholding" computer algorithm with the system microprocessors mapping each rivet location and noting the defective ones.

The Tool Head Frame. The tool head frame provides accuracy and stability for the operation of the smart tool head. Approximately 2' on a side, it is made of hollow aluminum tubing with pads on each of the 4 feet (see figure 11).

The frame must provide a working space of 4 feet<sup>2</sup> (although for some special applications a tool head frame greater than 4 feet<sup>2</sup> may be useful). Also, 8" or more are required for the turret to be able to operate on rivets near the edge of the tool frame head. The pads must have enough area to avoid skin buckle when the robot arm presses the tool head frame against the skin. There are many ways to design the rest of the tool head frame.

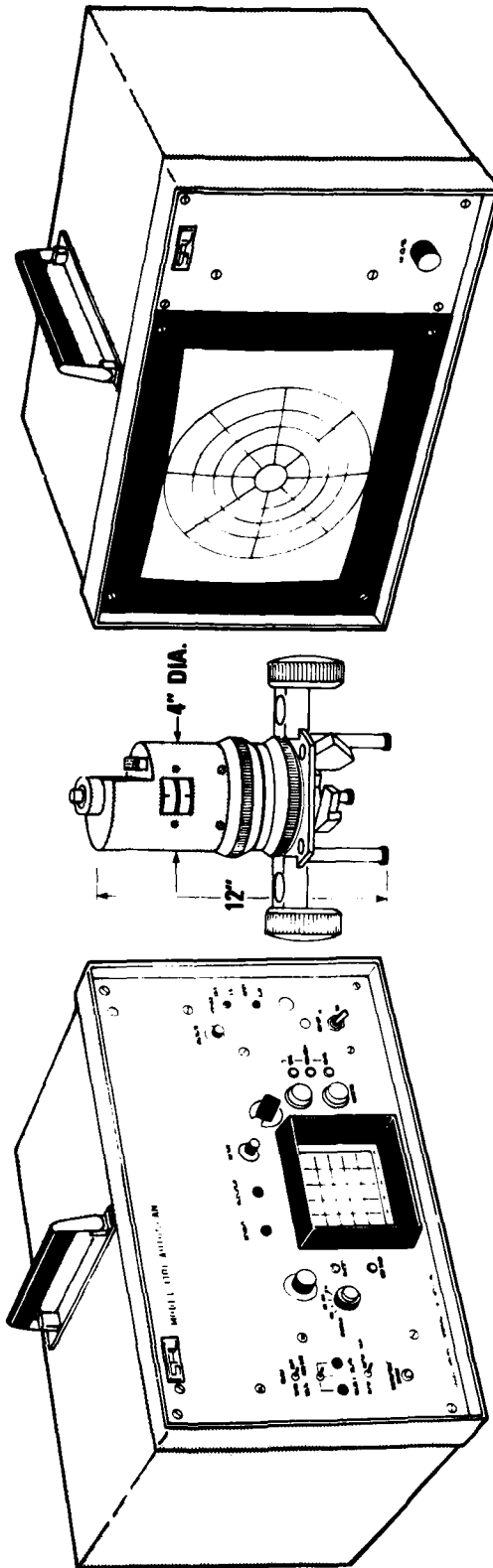

FIGURE 8 THE AUTOSCAN I SENSOR - HAND PORTABLE VERSION

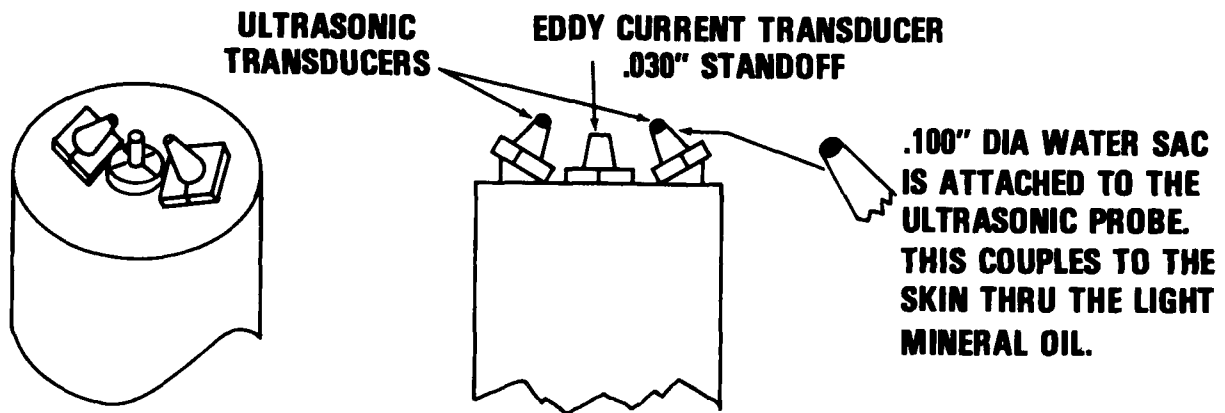
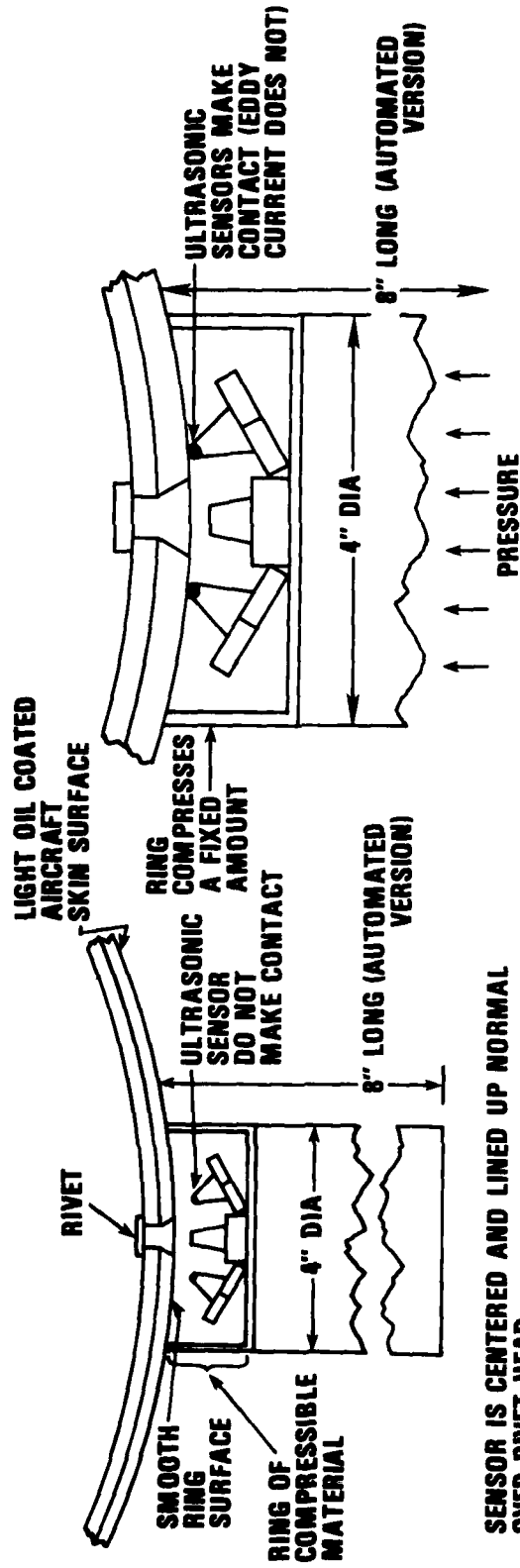

FIGURE 9 SENSOR HEAD DETAIL



SENSOR IS CENTERED AND LINED UP NORMAL OVER RIVET HEAD

(A) SEARCH PHASE

THE TURRET PASSES THE SENSOR HEAD AGAINST THE SKIN SURFACE. THE ULTRASONIC SENSORS MAKE SKIN CONTACT, ROTATE AND INSPECT.

(B) INSPECTION PHASE

FIGURE 10 POSSIBLE SIMPLE SENSOR MODIFICATION TO FACILITATE AUTOMATED SEARCH

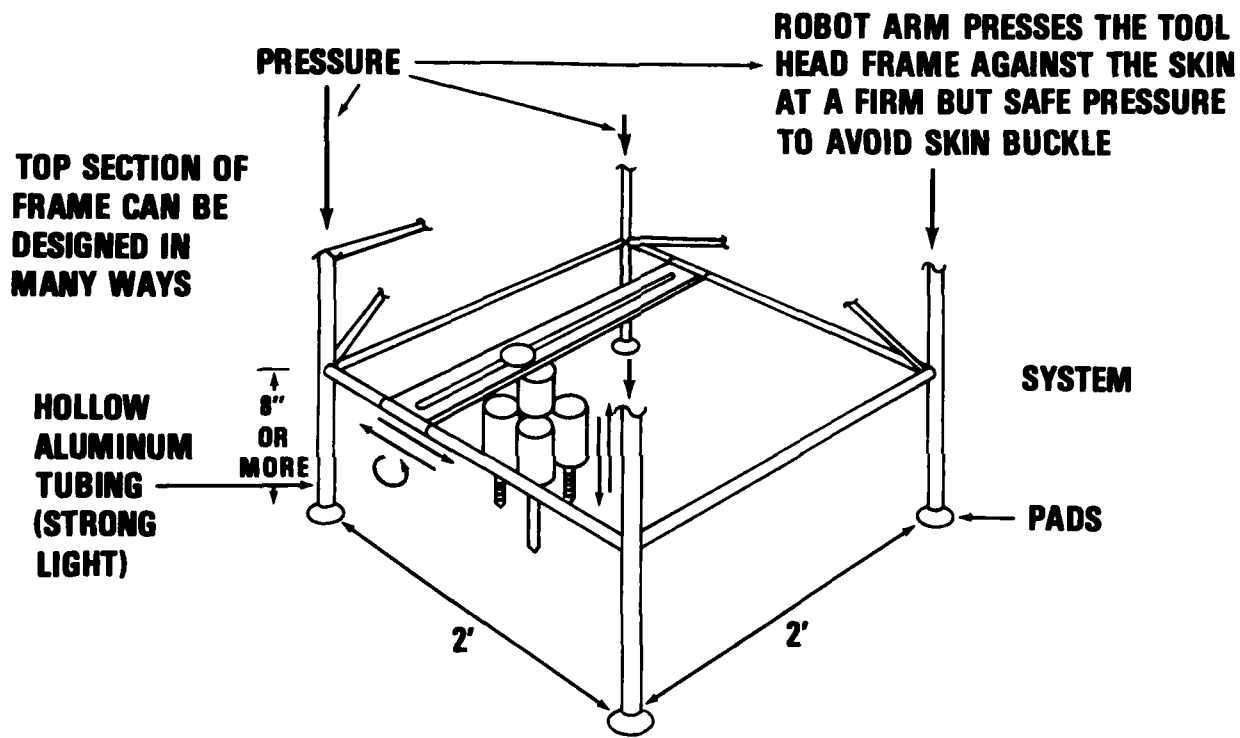
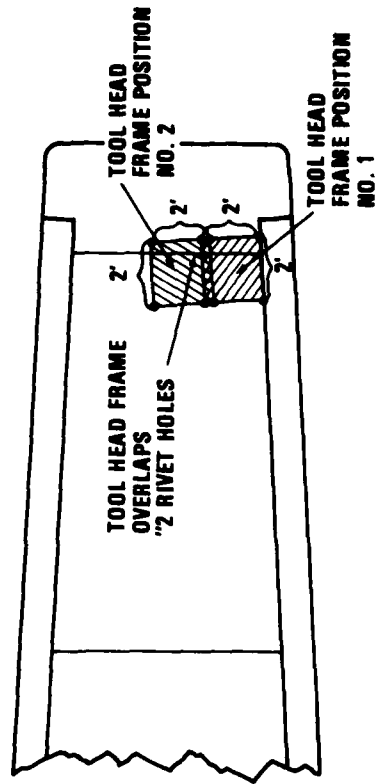

FIGURE 11 TOOL HEAD FRAME

B. THE VEHICLE AND ROBOTIC ARM. The robotic arm (see figure 1) must be programmable, must be able to access areas on several different kinds of aircraft, and must be able to carry large loads.

For the programmable aspects of the robotic arm, "lead and teach" is acceptable. "Lead and teach" is the original method of teaching a robot by leading it through its path, filing the joint and servo information into its computer and letting the computer drive the robot through the path again and again as necessary. Actually for the robotic deriveter, a modified "lead and teach" is best (see figure 12).

In the modified "lead and teach" method, the operator uses teleoperator controls to set the tool head down on the 4-corner tool head frame positions (figure 12a). When the program is put on automatic, the robotic arm positions the tool frame head in position #1 (figure 12b). It then holds the tool head frame steady in position #1 and at the correct pressure (a pressure gauge and control will be needed in the robotic arm) until the smart tool head completes its deriveting process in the 2' x 2' area enclosed by the tool head frame. At this point, the robotic arm automatically moves the smart tool head to position #2 (figure 12b) and begins the deriveting process again. It should be noted that the position #2 in figure 12b is different than the position #2 of figure 12a. Specifically, the robotic arm computer interpolates between the 4 "lead and teach" corner positions of figure 12a, and places the tool head frame in the respective optimum operating positions within the area defined by those 4 "lead and teach" corner positions. Details for this interpolation are as shown in figure 13.



(B) AUTOMATED ROBOTIC MOVEMENT OF THE TOOL HEAD FRAME

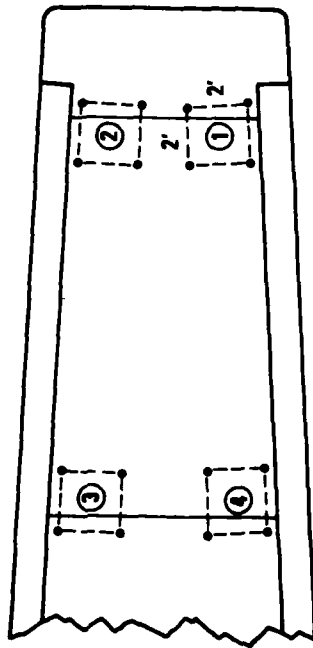

- ① TOOL HEAD FRAME POSITION NO. 1
- ② TOOL HEAD FRAME POSITION NO. 2
- ③ TOOL HEAD FRAME POSITION NO. 3
- ④ TOOL HEAD FRAME POSITION NO. 4

(A) ROBOT PROGRAMMING BY "MODIFIED LEAD AND TEACH"

FIGURE 12 ROBOT ARM PROGRAMMING AND AUTOMATED TOOL HEAD FRAME POSITIONING

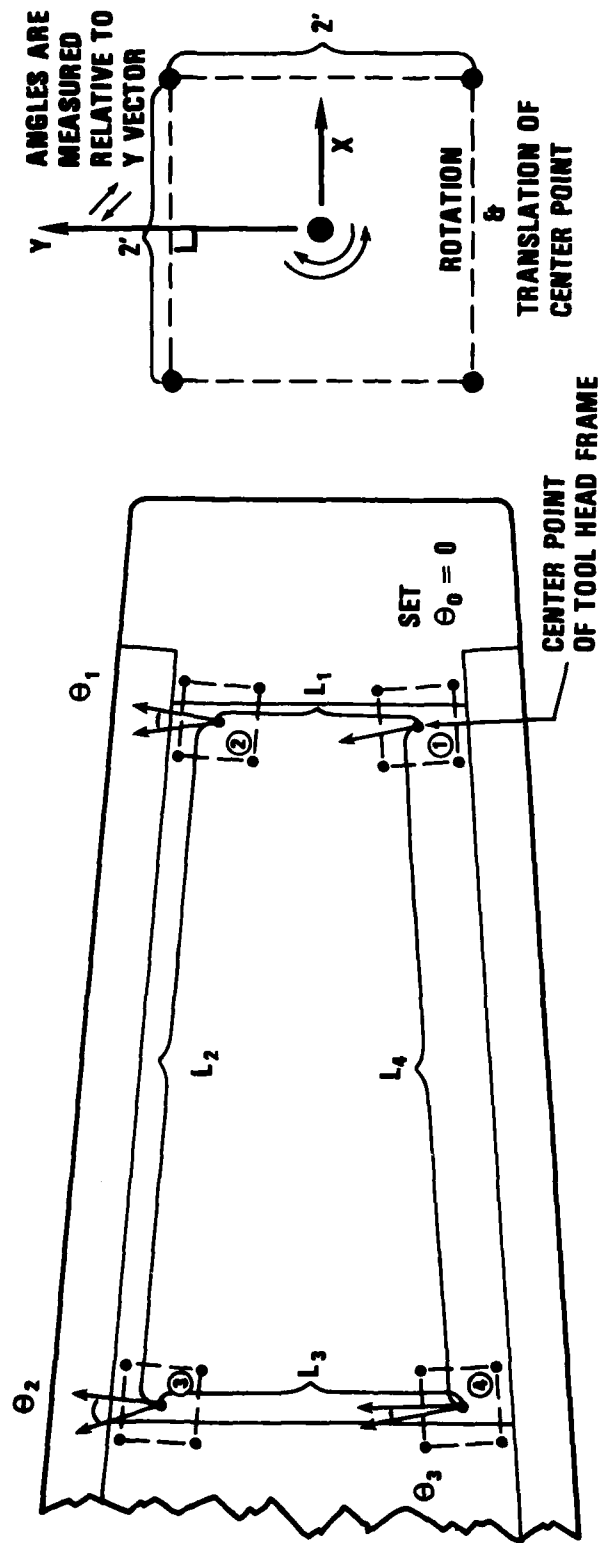

★NOTE: EACH VALUE FOR X-Y COORDINATES OF THE TOOL HEAD FRAME CENTER POINT ALSO HAS A Z VALVE

FIGURE 13 "MODIFIED LEAD AND TEACH" VALVES WHICH THE ROBOT KEYS ON

$L_1$  (ft)/4 = no. of tool head frame positions along the vector length  $L_1$  - Round up to nearest integer  $N_1$ .

$\vec{L}_1 / N_1$  = distance (in ft) the tool head frame must move for each of the  $N$  position changes.

(  $L_{1x} / N_1$  = x dist.;  $L_{1y} / N_1$  = y dist;  $L_{1z} / N_1$  = z dist.)

$\theta_1$  = total rotation (with respect to the Y axis) that the tool head frame makes along  $\vec{L}_1$  between pts 1 and 2.

$\theta_1 / N_1$  = rotation per each position change. Rotations need be considered for the x - y Plane only.

$L_2, L_3, L_4, \theta_2, \theta_3, \theta_4$  are handled in the same manner as  $L_1, \theta_1$ .

Again each successive tool head frame position must overlap 2 rivet holes of the previous position to permit proper tool head orientation (figure 12b).

Robotic Arm Aircraft Area Accessability. In figure 1, the robotic arm is shown giving the smart tool head accessability over the top of the wing. To do this it must have the degrees of freedom shown in figure 14.

Accessing the underside of the wing could be the toughest problem since the undersides of wings of Navy aircraft undergoing repair in NARFs (Naval Air Rework Facilities) are usually only about 6 ft or 7 ft off the ground.

The robotic arm should be able to support 500 lbs on the smart tool head to permit ample equipment to go on the tool head and to permit ample pressure for the tool head against the aircraft skin, particularly when working on the bottom of the wing. This, of course, means a custom robotic arm. But

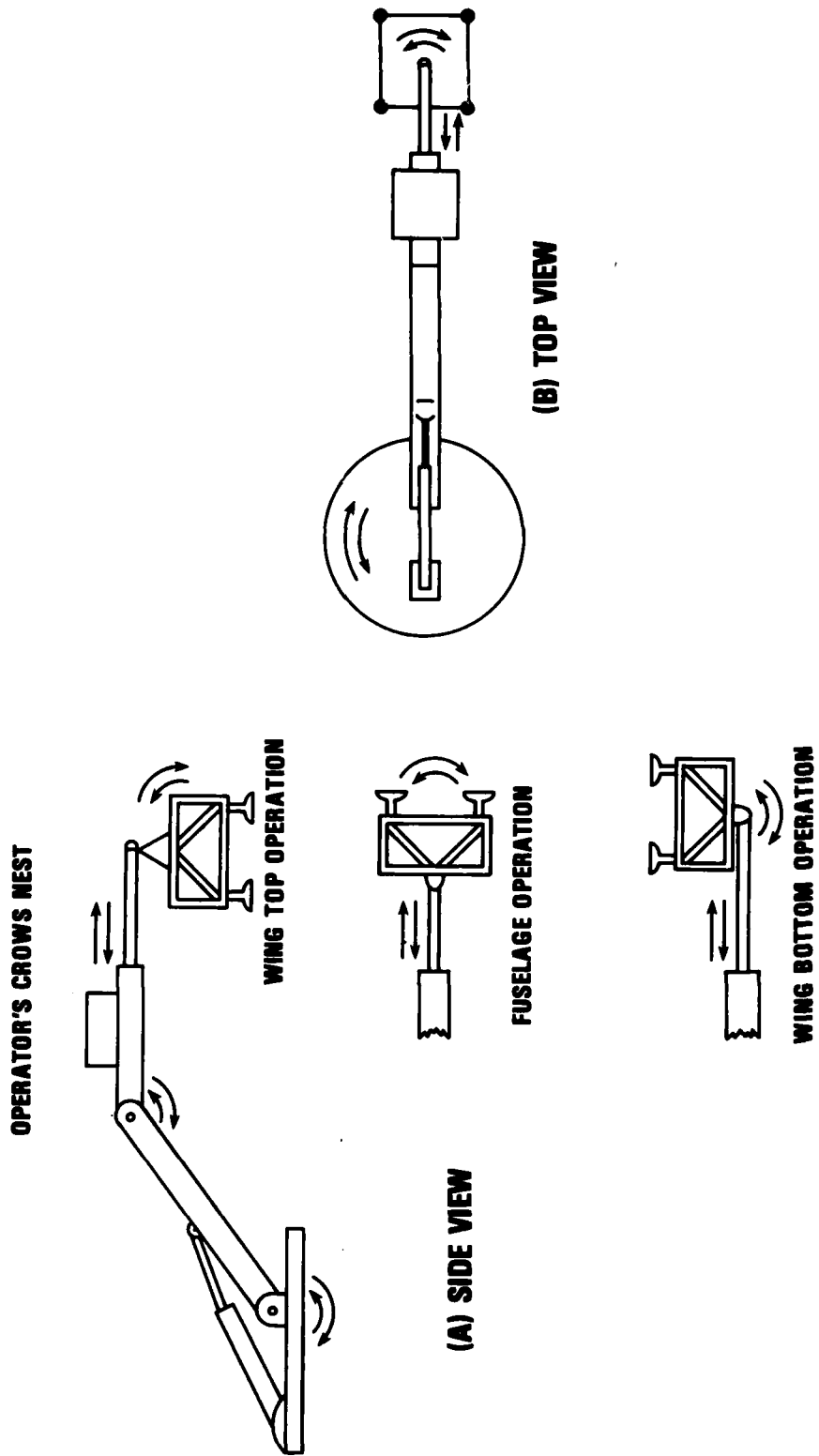

FIGURE 14 ROBOTIC ARM DEGREES OF FREEDOM

this has been done before. For example, the Navy Ship Yard in Long Beach, California, has built a custom arm (capable of handling a 2-ton tool head) for cleaning Navy ship hulls.

The Vehicle. Not too much needs to be said about the vehicle except to point out that it should provide a mobile, stable platform for the deriveting operations, should provide the required power (electrical, pneumatic, etc.) and accessories, and should be based on a commercial chassis to keep costs down and reliability up.

### C. AUTOMATIC DATA PROCESSING

1. The microprocessors needed and how they interrelate functionally are shown in figure 15.

2. What are the characteristics of each of these microprocessors? In general, insofar as possible, the same set of instructions should be used to program each microprocessor. In concert with this, the same family should be used where possible. Beyond this however, there are many ways the microprocessors can be organized and the automatic data processing accomplished.

a. The Sensor Microprocessor<sup>5</sup>. The microprocessors comes with the sensor. A special computer interface card and automated alignment and thresholding features for the sensor itself will be needed.

b. The Operating System Microprocessor<sup>6</sup> (in the command and control console). This microprocessor has the most involved computational load since it must keep track of the spatial location of up to 5,000 rivets, must supervise the entire system and must serve as the man-machine interface. Using a 16-bit microprocessor will give it rivet locations of  $2^{16}$  resolution and 2 bytes/location - more than what is needed. The rivet location matrix will require up to 30K of memory. The man-machine interface will require up to 16K. This interface will need custom software and operating instructions. Interfaces with the rest of the system and miscellaneous housekeeping tasks will require less than 16K. Thus, a 64K system should be more than adequate: 48K random access memory (RAM) and 16K electrically programmable read only memory (EPROM). Actually, for this system, a case can be made for a desk top minicomputer/interactive graphics display system.

---

<sup>5</sup>Ibid

<sup>6</sup>Interview, author and Eric Hein, NSWC Microprocessor/minicomputer Specialist, 6/23/80.

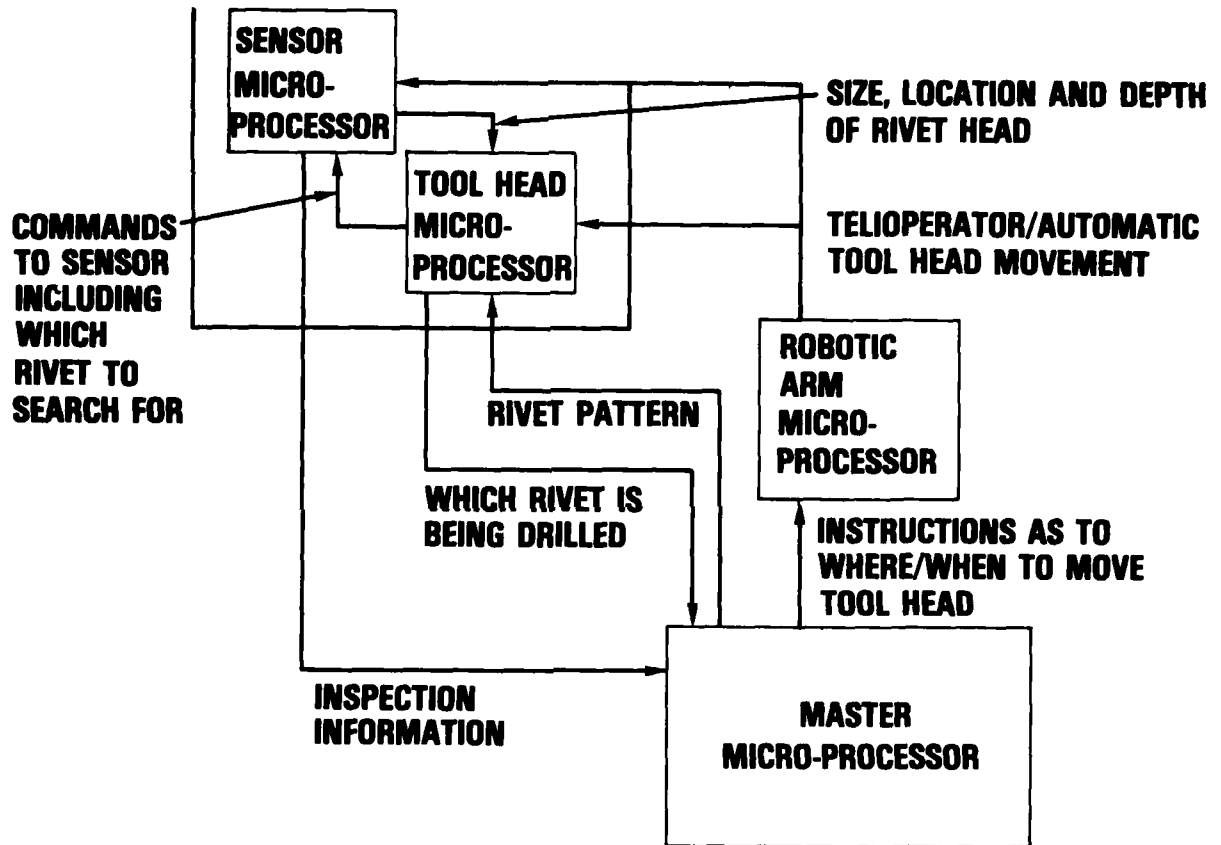

FIGURE 15 MICROPROCESSOR FUNCTIONAL RELATIONSHIPS

c. The Robotic Arm Microprocessor<sup>7</sup>. This microprocessor will no doubt be designed and built by the manufacturer of the robotic arm. It will be unique in that it will involve A/D and D/A converters (probably the main cost item) and servo/computer links and feedback. These items will be required for each degree of freedom for the robot. But for all these complications it is probably possible to handle all this by an 8-bit microprocessor which has 4K EPROM and 4K RAM.

d. The Smart Tool Head Microprocessor<sup>8</sup>. This microprocessor must deal with one rivet at a time and manage the activities at the tool head including the application of artificial intelligence. A Z-80 or 8080 type microprocessor of 4K memory (EPROM and RAM) should be sufficient.

3. Command and Control Console. The command and control console is illustrated in figure 16, which is for the most part self explanatory. The sensor display in the upper left portion of figure 16 is the analog ultrasonic display that comes with the ultrasonic sensor. The teleoperator controls on the right of the figure use standard TV displays. There is also a set of teleoperator controls in the bucket of the robot arm (figure 1).

#### IV. SUMMARY

This paper has presented a technical overview of the Navy Robotic Deriveter. First, a brief background discussion is given on the purpose and the design goals. Next, an overview is given on how the system works, and how the operator uses it. The flexibility and efficiency of the machine and the simplicity of operation are apparent. Design details and cost reduction features are shown.

---

<sup>7</sup>Ibid

<sup>8</sup>Ibid

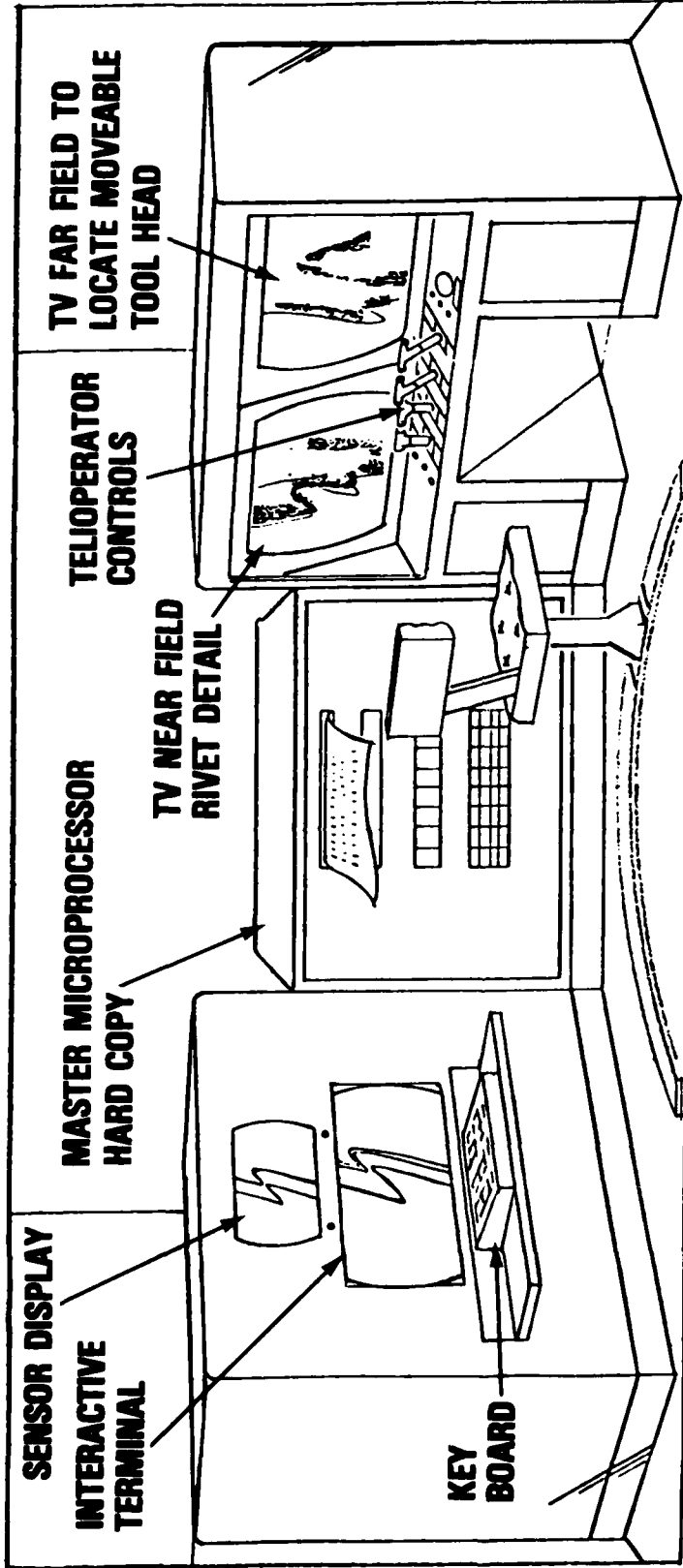

**COMMAND AND CONTROL ELEMENTS**

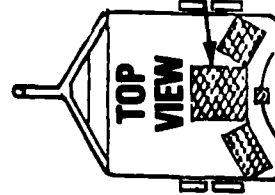

**PLACEMENT OF COMMAND AND CONTROL ELEMENTS INSIDE TRAILER**

FIGURE 16 COMMAND AND CONTROL CONSOLE CONCEPTUALIZATION

## DISTRIBUTION

	<u>Copies</u>		<u>Copies</u>
Chief of Naval Material		Commanding Officer	
Attn: J.W. Tweedale OASN	1	Naval Weapons Station	
D. Carstater (MAT 622)	1	Attn: CDR T.E. Dyer	1
F. Holden (MAT 382)	1	Yorktown, Virginia 23691	
Navy Department		Commanding Officer	
Washington, D.C. 20360		Naval Air Rework Facility	
Commander		Attn: Forrest Gale (640.1)	1
Naval Air Systems Command		Naval Air Station	
Attn: C. Caposell (612)	1	North Island	
R. Retta (1012)	1	San Diego, California 92135	
L. Talbut (04A)	1	Commander	
E.D. Cooper (03)	1	Naval Aviation Logistics Center	
Naval Air Systems Command		Attn: CAPT K. Tracy	1
Headquarters		Naval Air Station	
Washington, D.C. 20361		Patuxent River, Maryland 20670	
Commander		Defense Technical Information Center	
Naval Sea Systems Command		Cameron Station	
Attn: Raye Parrott	1	Alexandria, Virginia 22314	12
Thomas U. Draschil	1		
Harry Byron	1		
Code 04	1		
Naval Sea Systems Command			
Washington, D.C. 20362			

TO AID IN UPDATING THE DISTRIBUTION LIST  
FOR NAVAL SURFACE WEAPONS CENTER, WHITE  
OAK TECHNICAL REPORTS PLEASE COMPLETE THE  
FORM BELOW:

TO ALL HOLDERS OF NSWC/TR 80-353  
by John M. Vranish, Code EIA

DO NOT RETURN THIS FORM IF ALL INFORMATION IS CURRENT

---

A. FACILITY NAME AND ADDRESS (OLD) (Show Zip Code)

---

NEW ADDRESS (Show Zip Code)

---

B. ATTENTION LINE ADDRESSES:

---

C.

REMOVE THIS FACILITY FROM THE DISTRIBUTION LIST FOR TECHNICAL REPORTS ON THIS SUBJECT.

---

D.

NUMBER OF COPIES DESIRED \_\_\_\_\_

**DEPARTMENT OF THE NAVY  
NAVAL SURFACE WEAPONS CENTER  
WHITE OAK, SILVER SPRING, MD. 20910**

**OFFICIAL BUSINESS  
PENALTY FOR PRIVATE USE, \$300**

**POSTAGE AND FEES PAID  
DEPARTMENT OF THE NAVY  
DOD 316**



**COMMANDER  
NAVAL SURFACE WEAPONS CENTER  
WHITE OAK, SILVER SPRING, MARYLAND 20910**

**ATTENTION: CODE E1A**