

AD-A097 290

NAVAL POSTGRADUATE SCHOOL MONTEREY CA
A STRUCTURE FOR THE DEVELOPMENT OF AN ENGINEER MODEL.(U)
DEC 80 P J SLATTERY

F/G 9/2

UNCLASSIFIED

NL

1 of 2

AD-A097 290

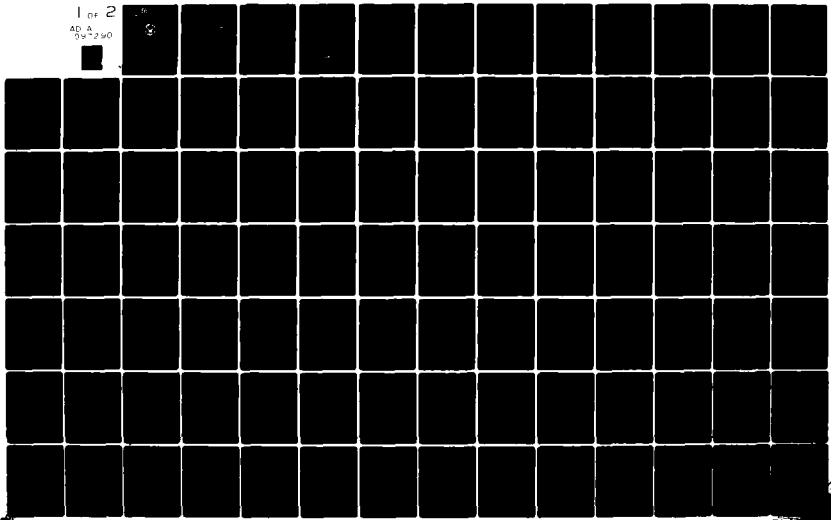

LEVEL II

2

NAVAL POSTGRADUATE SCHOOL
Monterey, California

AD A 097290

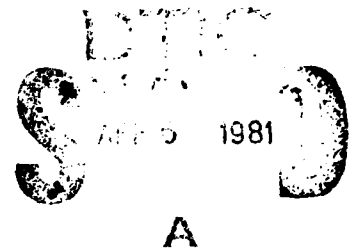

THESIS

A STRUCTURE FOR THE DEVELOPMENT
OF AN ENGINEER MODEL

by

Patrick J. Slattery

December 1980

Thesis Advisor:

J. K. Hartman

Approved for public release; distribution unlimited.

DTIC FILE COPY

81 4 3 032

UNCLASSIFIED

SECURITY CLASSIFICATION OF THIS PAGE (When Data Entered)

REPORT DOCUMENTATION PAGE		READ INSTRUCTIONS BEFORE COMPLETING FORM
1. REPORT NUMBER	2. GOVT ACCESSION NO.	3. RECIPIENT'S CATALOG NUMBER
	AD-A094	2.90
4. TITLE (and Subtitle)	9	5. TYPE OF REPORT & PERIOD COVERED
(6) A Structure for the Development of an Engineer Model,		Master's Thesis December 1980
		6. PERFORMING ORG. REPORT NUMBER
7. AUTHOR(s)		8. CONTRACT OR GRANT NUMBER(s)
(10) Patrick J. Slattery		
9. PERFORMING ORGANIZATION NAME AND ADDRESS		10. PROGRAM ELEMENT, PROJECT, TASK AREA & WORK UNIT NUMBERS
Naval Postgraduate School Monterey, California 93940		(12) 107
11. CONTROLLING OFFICE NAME AND ADDRESS	11	12. REPORT DATE
Naval Postgraduate School Monterey, California 93940		Dec 1980
14. MONITORING AGENCY NAME & ADDRESS (if different from Controlling Office)		13. NUMBER OF PAGES
		106
		15. SECURITY CLASS. (of this report)
		Unclassified
		16. DECLASSIFICATION/DOWNGRADING SCHEDULE
16. DISTRIBUTION STATEMENT (of this Report)		
Approved for public release; distribution unlimited.		
17. DISTRIBUTION STATEMENT (of the abstract entered in Block 20, if different from Report)		
18. SUPPLEMENTARY NOTES		
19. KEY WORDS (Continue on reverse side if necessary and identify by block number)		
Engineer model Obstacles Obstacle emplacement		
20. ABSTRACT (Continue on reverse side if necessary and identify by block number)		
This thesis presents the basic outline and structure for the development of an engineer model which will be incorporated into the STAR land combat simulation model. A discussion of common engineer missions, U.S. and Soviet engineer units, and their organizations and methods of operation, is used to motivate the focusing of attention on two events which are the emplacement and the breaching of obstacles fields.		

DD FORM 1473 1 JAN 73

EDITION OF 1 NOV 68 IS OBSOLETE
S/N 0102-014-6001

UNCLASSIFIED 252450

SECURITY CLASSIFICATION OF THIS PAGE (When Data Entered)

UNCLASSIFIED

SECURITY CLASSIFICATION OF THIS PAGE/When Data Entered:

Several measures of effectiveness are suggested for use in determining how obstacles, and thereby engineer forces, influence the battle and battle outcome.

DD Form 1473
1 Jan 73
S/N 0102-014-6601

2

UNCLASSIFIED

SECURITY CLASSIFICATION OF THIS PAGE/When Data Entered:

Approved for public release; distribution unlimited.

A Structure for the Development
of an Engineer Model

by

Patrick J. Slattery
Captain, United States Army
B.S., Polytechnic Institute of Brooklyn, 1971

Submitted in partial fulfillment of the
requirements for the degree of

MASTER OF SCIENCE IN OPERATIONS RESEARCH

from the

NAVAL POSTGRADUATE SCHOOL
December 1980

Accession For	
NTIS GRA&I	<input checked="" type="checkbox"/>
DDIC TAB	<input type="checkbox"/>
Unannounced	<input type="checkbox"/>
Justification	<input type="checkbox"/>
By	
Distribution/	
Availability Codes	
Avail and/or	
Dist	Special
<input checked="" type="checkbox"/>	<input type="checkbox"/>

Author

Patrick J. Slattery

Approved by:

James K. Hartman

Thesis Advisor

James G. Taylor

Second Reader

[Signature]
Chairman, Department of Operations Research

H. M. Woods

Dean of Information and Policy Sciences

ABSTRACT

→ This thesis presents the basic outline and structure for the development of an engineer model which will be incorporated into the STAR land combat simulation model. A discussion of common engineer missions, U.S. and Soviet engineer units, and their organizations and methods of operations, is used to motivate the focusing of attention on two events which are the emplacement and the breaching of obstacles fields. Several measures of effectiveness are suggested for use in determining how obstacles, and thereby engineer forces, influence the battle and battle outcome. ↗

TABLE OF CONTENTS

I.	INTRODUCTION-----	7
II.	MISSIONS-----	9
	A. GENERAL-----	9
	B. MOBILITY-----	9
	C. COUNTERMOBILITY-----	10
	D. SURVIVABILITY-----	10
	E. GENERAL ENGINEERING WORK-----	11
III.	ENGINEER UNITS-----	12
	A. GENERAL-----	12
	B. U.S. ENGINEER UNITS-----	12
	C. SOVIET ENGINEER UNITS-----	18
IV.	OBSTACLES-----	24
	A. DEFINITIONS-----	24
	B. PURPOSE-----	24
	C. EMPLOYMENT-----	25
	D. CONCEPT OF STANDARD PACKAGES-----	26
V.	ENGINEER MODEL-----	28
	A. GENERAL-----	28
	B. SYSTEM ENTITIES-----	28
	C. SYSTEM BOUNDARY-----	30
	D. RESOLUTION-----	31
VI.	ENGINEER ROUTINE-----	33
	A. THE ENGINEER ROUTINE AS A PREPROCESSOR-----	33

B.	WHAT THE ENGINEER ROUTINE WILL DO-----	34
C.	WHAT INPUT IS NEEDED-----	35
D.	REQUIRED ROUTINES-----	40
VII.	OBSTACLE ENCOUNTER-----	45
A.	GENERAL-----	45
B.	OBSTACLE RECONNAISSANCE-----	45
C.	GENERATING A BYPASS ROUTE-----	47
D.	BYPASSING AN OBSTACLE-----	53
E.	RISK OF CANALIZATION-----	54
F.	BREACHING OF OBSTACLES-----	54
VIII.	MEASURES OF EFFECTIVENESS-----	58
A.	GENERAL-----	58
B.	BATTLE OUTCOME-----	58
C.	DELAY TIME-----	59
IX.	CONCLUSIONS AND RECOMMENDATIONS-----	62
	APPENDIX A: ENGINEER UNIT ASSETS-----	64
	APPENDIX B: OBSTACLE DESCRIPTION AND STANDARD PACKAGE---	73
	APPENDIX C: FLOW CHART OF MODIFICATIONS TO FLD. INIT----	85
	APPENDIX D: FLOW CHARTS OF BREACHING LOGIC-----	89
	LIST OF REFERENCES-----	105
	INITIAL DISTRIBUTION LIST-----	106

I. INTRODUCTION

Currently the Simulation of Tactical Alternative Responses (STAR) (1) model does not include the simulation of combat engineer missions in either the offense or the defense. The absence of the engineer units means that the combined arms team has not been modeled completely and the synergistic effect of the team has not been fully captured. Therefore, to further enhance the STAR model there is a need to develop an engineer model. The purpose of this thesis is to define the structure of this engineer model.

The primary function of the combat engineer force is, by accomplishing various engineer missions, to increase the supported maneuver unit's ability to fight effectively. The effectiveness of the engineer forces and their impact on battle outcome cannot be measured unless the missions which they accomplish are represented in the model. Once an engineer model is implemented, excursions can be taken to investigate the merits of various deployment and support relationships between different sized elements of engineer and maneuver units. Additionally, attempts could be made to isolate the effectiveness of various combinations of weapon systems and obstacles so as to determine maximum return for effort expended in emplacing obstacles.

The first several chapters of this thesis present an overview of the engineer forces and serve as an introduction for those individuals who are not familiar with engineer operations. The remaining chapters describe the engineer model and its structure. Chapter II describes the basic engineer missions as they are usually categorized. The composition of the U.S. and the Soviet engineer forces, their specific missions and their organizations, are outlined in Chapter III. Chapter IV discusses in detail the function of obstacles on the battlefield, the various types of obstacles and how they are employed. The structure of the engineer model is described in Chapter V and the routines which are required to implement the model are discussed in the following chapter. Chapter VII discusses obstacle encounter and the logic required to model this occurrence. Chapter VIII discusses several measures of effectiveness which can be used to answer the basic question of whether or not the engineer force increases the effectiveness of the maneuver force. Chapter IX presents the conclusions of this work and areas which will need to be expanded and improved upon.

II. MISSIONS

A. GENERAL

The purpose of the engineer forces is to fight as part of the combined arms team as far forward as possible. By their organization, special skills and equipment, the engineer forces have the assets to perform unique missions that can increase the combat capability of the units that they support. These missions can be categorized into the following four functional areas:

1. mobility
2. countermobility
3. survivability
4. general engineering work.

The work accomplished by the divisional engineers is typified by quick, expedient work. The corps engineers improve upon this work and maintain it.

B. MOBILITY

Mobility "is oriented toward reducing or negating the effects of existing or reinforcing obstacles to improve the movement of maneuver/fire units and movement of critical supplies"[7]. The maneuver units must be able to move on the battlefield in order to concentrate forces and firepower at critical places. In the defensive situation, this means being able to advance as well as to move laterally from battle position to battle position. In the offense, the engineer force

must work well forward to clear advance routes through natural barriers and enemy emplaced obstacles. The common mobility operations are:

1. Breaching craters or ditches
2. Demolition and removal of road blocks, trees, or rubble
3. Making quick bypasses around obstacles
4. Clearing paths through minefields
5. Spanning gaps
6. Making combat trails through wooded and heavily vegetated areas.

Though these mobility missions can be in support of both offensive and defensive operations, they usually are associated with the offense and the encountering and breaching of obstacles.

C. COUNTERMOBILITY

The purpose of the countermobility operation is to reduce the ability of the enemy to maneuver and thereby reduce his combat effectiveness. These missions are defense oriented and are typified by the emplacement of obstacles in the enemy's advance route. The subject of obstacles and their emplacement will be discussed in detail in the following chapters.

D. SURVIVABILITY

Survivability is the construction of protective positions for both weapon systems and critical supplies. These positions

are expedient and provide protection against direct and indirect fire. Generally, the preparation of defilade positions of the forward deployed forces is the responsibility of the divisional engineers. The majority of the remaining survivability work is to be accomplished by the corps engineer units.

E. GENERAL ENGINEERING WORK

All other engineer missions can be placed in one catch-all category. These are missions that generally are found in the brigade or division rear area and do not contribute directly to the outcome of the main battle. They usually are assigned to corps engineer units for accomplishment.

Typical missions are:

1. Improve and maintain main supply routes
2. Prepare field artillery positions
3. Repair airfields
4. Replace assault bridging with tactical bridging.
5. Provide water.

These missions will not be addressed further since the thrust of the STAR model at this time is directed at the forward battle area rather than the activities in the rear areas.

III. ENGINEER UNITS

A. GENERAL

The purpose of this chapter is to present an overview of the U.S. and Soviet engineer units which influence the battle in the main battle area. This overview is not meant to be exhaustive, but to present the more common engineer missions chartered to these units and the major assets which they have to accomplish these tasks.

B. U.S. ENGINEER UNITS

Engineer units are greatly varied in composition and are structured to perform specific missions. There are nine different battalion organizations and over forty different company sized units. At the battalion level, the units range from divisional engineers to battalions responsible for the production of topographic maps. Even among the divisional engineer battalions, the units are tailored to the specific division they support. For example, the engineer battalion in support of an airborne division is smaller and has different sets of construction equipment than the battalions in support of the other various types of divisions. At the company level, the units vary from those responsible for atomic demolition munitions (ADM) missions to port construction to pipeline construction.

The discussion of the U.S. engineer forces will be restricted to the divisional engineers and the corps combat engineer battalions and their organic companies. This restriction is imposed so as to concentrate on those forces which are found in and impact on the battle in the forward division and brigade area. Since there are only armored and mechanized infantry divisions currently deployed in Europe, the discussion of divisional engineer battalions will be restricted to those battalions which support these two types of divisions.

1. Divisional Engineer Battalion

a. Mission and Capabilities

The primary mission of the battalion is to increase the combat effectiveness of the division by performing those tasks which were discussed in the previous chapter. To accomplish these tasks the unit has the capability to:

- (1) Emplace and remove obstacles
- (2) Engage in hasty stream crossings; coordinate the organic and attached engineers in a deliberate stream crossing
- (3) Assist in the assault of fortified positions
- (4) Construct and maintain assault bridges, fords, helipads and combat trails
- (5) Provide potable water
- (6) Provide engineer reconnaissance
- (7) Provide technical assistance to other troops in the preparation of fortifications and camouflage.

The secondary mission of the unit, and the secondary mission of all engineers, is to reorganize and fight as infantry. It should be noted that the engineer battalion does not have much firepower. The only anti-tank system it possesses is the LAW and the heaviest weapon is the M-2 50-calibre machinegun. Therefore, for the unit to fight effectively as infantry, it must receive additional firepower assets from the division.

b. Organization

The organization of the engineer battalion which supports the armored or mechanized infantry division is basically the same. Total personnel strength is over 900 officers and enlisted men. They are organized into a headquarters and headquarters company (HHC), four combat line companies and a bridge company. The type of bridging found in the bridge company may vary among divisions. Each of these units will be discussed below.

c. Commander

The battalion commander must perform the functions of the unit commander as well as the senior engineer staff officer to the division commander. To assist him in this role as the engineer advisor, he has a major, who is called the assistant division engineer (ADE), and a senior non-commissioned officer located at the division headquarters. They directly assist the division operations officer in planning the utilization of all engineer assets.

d. HHC

This company is comprised of the various battalion staff and support sections. There are several unique sections within this unit that are not found in the HHCs of the maneuver battalions. Within the S-4 (Logistics) organization there are several sections, of which one is the dump truck section. This section has six 5-ton dump trucks with trailers that are used for hauling supplies and obstacle material. Also found in the HHC is the heavy equipment platoon which contains the heavy combat construction assets of the unit. The platoon has four road graders, three bulldozers and transports, and two cranes. This equipment can be assigned missions on a task-by-task basis or attached to a line company for support in the accomplishment of various missions such as anti-tank ditching. A summary of the equipment assets is listed in Appendix A (Engineer Unit Assets).

e. Line Company

The four line companies are identically structured. Three of the companies are placed in direct support of the maneuver brigades. The fourth company can be assigned missions such as support of the covering force, support of one of the other line companies, or assigned missions on a task basis in general support of the division. With a line company in support of a brigade, it is not uncommon to place a platoon in support of a maneuver battalion, and a squad in support of a maneuver company. The engineer company commander

must also perform as the engineer staff officer to the brigade commander, while the platoon leaders are staff officers to the battalion commanders they support. Thus, with the commanders from battalion to platoon level serving in two roles and with the unit's elements dispersed in support of various maneuver forces, the command and control and the flow of mission directives is a complicated procedure which can be easily strained.

The company consists of four platoons which are a headquarters and three line platoons. The headquarters platoon contains the communications, mess, supply, and maintenance sections for the unit. Within this platoon are found the company's two combat engineer vehicles (CEV), the bulldozer and its transporter, a 5-ton dump truck, and the pneumatic tool set. This equipment is kept under the commander's control and is allocated to the line platoons on a mission basis. Each of the line platoons has a headquarters squad and three line squads. The equipment found in the headquarters squad is the platoon's scooploader, a 5-ton dump truck with trailer, an electric tool trailer with a 3 KW generator, several tool sets and mine detectors. The equipment found in the line squads consists of an M113 armored personnel carrier (APC) as the squad vehicle, a trailer for hauling obstacle material, three tool sets (demolition, carpenter, and pioneer), a chain saw and a metallic and a non-metallic mine detector.

f. Bridge Company

The assault bridging assets of this company may vary among the divisions. However, the more common company organization is currently the mobile assault bridge (MAB). This company cannot, by itself, support a divisional size stream crossing operation. With its organic assets, the unit could support a brigade size crossing.

In addition to the 16 interior and 8 end bays which comprise the assault bridging assets, the unit has a 20-ton crane, four armored vehicle launched bridge (AVLB) launchers, six AVLB bridges, a bulldozer, transporters for the extra bridges and the dozer, 18 15-man assault boats and two light tactical raft (LTR) sets.

2. Corps Combat Battalions

a. Mission and Capabilities

The mission of the corps combat engineer battalion is to increase the combat effectiveness of the corps by providing engineer combat support and to reinforce divisional engineer units when required. The unit has the capabilities to:

- (1) Construct, repair, and maintain roads, fords, culverts, landing strips, heliports, command posts, supply installations, structures and related facilities
- (2) Prepare and remove obstacles
- (3) Provide potable water
- (4) Construct defensive installations

- (5) Engage in river crossing operations to include assault crossing of troops and construction of tactical rafts and bridges
- (6) Participate in the assault of fortified positions
- (7) Plan and prepare sites and supervise ADM teams in the execution of ADM missions.

b. Organization

The battalion is organized into an HHC and four line companies.

(1) HHC. The general organization of the HHC is similar to that of a divisional battalion. It is augmented by an equipment platoon and a combat construction section which contains plumbers, carpenters, and other skilled construction trade workmen. The equipment platoon consists of three cranes, four road graders, two scooploaders, a skid-mounted earth auger, a sheepsfoot roller, four 5-ton dump trucks, a pneumatic tool set and several other pieces of construction equipment.

(2) Line Company. The four line companies are identical in structure to each other and only differ from the divisional engineer line company in that the squad vehicle is the 5-ton dump truck instead of an APC.

C. SOVIET ENGINEER UNITS

The structure and composition of the Soviet engineer forces are very similar to those of the U.S. However, their employment, especially in the offense, differs from our doctrine. "Soviet planners recognize that execution of combined

arms operations on the modern battlefield will require the efficient performance of engineering tasks....The force structure allows for reinforcement of basic engineer organizations with assets of senior commanders; the basic pattern of higher-to-lower reinforcements is found." [8]. For this reason, a great emphasis is placed on engineers being placed well forward and many routine engineering tasks are delegated to maneuver units or to engineers from the follow-on echelons for accomplishment. Each motorized rifle and tank regiment has an organic engineer company and each division has an organic engineer battalion. An Army usually will have two engineer regiments and the Front (Army Group) will have an additional three or four engineer regiments. The discussion of the Soviet engineers will be restricted to those units supporting the separate regiments and the division. The missions of these engineers are identical to those of the U.S.

1. Special Detachments

The Soviet maneuver commanders may reorganize their engineer assets into special detachments to support specific operations. The two most common detachments are the Movement Support Detachment (OOD) and the Mobile Obstacle Detachment (POZ).

a. OOD

The OOD normally moves behind the reconnaissance units and one to two hours before the head of the march formation. The OOD's mission is to perform obstacle reconnaissance,

reduce obstacles for passage, perform minor road and bridge maintenance, and to mark primary or alternate routes. To accomplish these tasks the OOD is organized into several groups which are the reconnaissance and barricade destruction group, the road and bridge group, and the route marking group. The size of each of these groups is a function of the desired rate of advance, anticipated enemy resistance, and terrain. Depending on the availability of engineer resources, each of the OOD groups may be broken up into smaller ones and given specific missions for accomplishment. Likewise, the mission of route marking may be tasked to a maneuver unit if the OOD resources become overly constrained. If heavy enemy resistance is encountered, the advance guard will pass through the OOD and the OOD will continue its missions and follow behind the first echelon. Its primary mission will change to preparing the advance routes for the second echelon.

b. POZ

POZs are positioned on the flanks of the march column. Their mission is to seal the flanks of the column from ground attack by laying minefields. The detachment normally consists of armored tracked minelayers and their support vehicles for transport of the mines. The detachment may be augmented by helicopter mine dispensing units. The POZ is used in both offensive and defensive operations.

2. Regimental Engineer Companies

The engineer company organic to a motorized rifle or a tank regiment consists of three platoons: a combat engineer, a bridge and a technical platoon.

a. Combat Engineer Platoon

This platoon consists of three combat squads mounted in armored personnel carriers each with a mine-laying trailer (PMR-3). Their function is to provide normal engineer support of obstacle creation or reduction. The platoon may be used to form a POZ.

b. Bridge Platoon

The platoon's mission is to provide assault crossing capability over small wet and dry gaps. To accomplish this, the platoon has four truck-launched scissor bridges (TMM) and from one to three tank-launched cantilever bridges (MTU). This platoon may be used to form part of the OOD.

c. Technical Platoon

This platoon contains the combat construction assets of the company which are: a tractor dozer (BAT), a trencher (BTM), a crane shovel (E-305U) and a bucket excavator. This platoon also may be used to form part of the OOD.

3. Divisional Engineer Battalion

The divisional engineer battalion consists of four companies: a combat engineer, a technical, a pontoon bridge and an amphibious company. The battalion's mission is to provide engineer support to the division.

a. Combat Engineer Company

This company provides the "sapper" support to division and has three combat engineer platoons and a mine-laying platoon. The three line platoons each have three armored personnel carriers with mounted mineclearing equipment (BTR-50K) as the squad vehicle and two vehicle mounted mine detectors (DIM). The mine-laying platoon has three armored tracked minelayers (BTR-152). This platoon may be used to form the POZ.

b. The Technical Company

The technical company provides the construction and fixed bridging assets for the division. It is organized into three platoons. The bridge platoon, which may be used to form the OOD, has four truck launched scissor bridges and three tank launched cantilever bridges. The road construction platoon, likewise, can be used to form part of the OOD, has six BAT tractor dozers, two crane shovels, two armored engineer tractors, two road graders and two wheeled dozers. The third platoon is the position preparation platoon. It is outfitted with two trenchers and two ditchers, and as its name implies, is given the mission of preparing positions for the maneuver units when they stop for more than 12 hours.

c. Pontoon Bridge Company

The pontoon bridge company consists of 18 sections of folding pontoon bridge (PMP) and six power erection boats. The PMP is both truck mounted and truck launched and

capable of carrying a normal 60 ton load. The U.S. ribbon bridge was designed from the PMP which can be utilized as either a bridge or a ferry.

d. Amphibious Company

This company is organized into two platoons. The tracked amphibious platoon has two amphibious carriers (PTS) which can be used to transport personnel, cargo, or equipment across water barriers or through marsh areas. The ferry platoon consists of six to twelve self-propelled ferries (GSP). Two of these GSP units mate together to form a single ferry which is capable of carrying a 60 ton load.

IV. OBSTACLES

A. DEFINITIONS

1. Obstacle: "An obstacle is any terrain feature, condition of soil, climate, or man-made object other than firepower that is used to stop, delay or divert enemy movement." [4]. The term firepower does not preclude the use of minefields.

2. Barrier: "A coordinated series of obstacles designed or employed to canalize, direct, restrict, delay or stop the movement of an opposing force and to impose additional losses in personnel, time and equipment on the opposing force." [5].

B. PURPOSE

As stated in the definitions, the primary purpose of a barrier, and hence an obstacle, is to counter enemy mobility.

The obstacle can cause the enemy to:

1. Be canalized into kill zones
2. Be held longer in the firing windows of the defenders' weapon systems
3. Lose time which may destroy the effect of a coordinated attack and concentration of fires.

The greatest contribution of obstacles to the tactical scheme is providing time, time which allows the defenders to:

1. Concentrate forces at a critical battlefield location

2. Assist in target acquisition
3. Destroy targets.

In the case of minefields, a secondary contribution is that the obstacle itself can inflict losses.

C. EMPLOYMENT

1. Siting

Each obstacle is selected to perform a certain function, such as to canalize or delay the enemy. Therefore, its siting or actual location on the ground is critical. If an obstacle that is emplaced with the purpose of delaying an enemy formation, so as to allow better target acquisition, is placed outside the range of the defenders' weapon systems, the obstacle will not be effective, although it may delay the enemy. Likewise, there will be no delaying of the enemy if a road crater is placed where there is an immediate bypass. The shifting of an obstacle a few meters may move it out of the line of sight of the defenders or make it readily visible to the attackers. Therefore, improper siting will have a serious impact on the effectiveness of the obstacle.

2. Direct Fire

Most obstacles do not inflict casualties. They must be covered by direct fire weapon systems in order to serve a meaningful purpose. Failure to do so will cause the enemy the inconvenience of a time delay as they search for a bypass or accomplish an unopposed breach. Lack of cover by direct

fire weapons implies that the engineer effort used to emplace the obstacle could have been utilized better in accomplishing other, more important missions.

D. CONCEPT OF A STANDARD PACKAGE

The number of direct types of obstacles is near limitless. Any object or created condition that can be used to restrict or delay movement, such as blocking a defile with abandoned cars or by local flooding, is an obstacle. In planning a defensive action, the types of obstacles to be used usually are restricted to the following types:

1. Minefields
2. Road craters
3. Bridge demolitions
4. Road block by log obstacles
5. Wire.

Likewise, the remaining discussion will be restricted to these more commonly used obstacles.

The concept of standard packages is to take these commonly used obstacles and standardize their characteristics such as size, effort, and time of emplacement. Thereby all road-craters will be of the same dimensions, create the same obstacle and will require the identical amount of material support.

Standard packages have the property of being additive. For example, if a standard road-crater crater will not accomplish the desired obstacle effect, two standard packages could be used. The packages could be added together to create either a wider or a longer crater. The material, time and

manpower required for emplacement would be twice that of a single package.

An additional advantage of the standard package is that it would reduce the amount of combat model computer input that would be required to describe an obstacle field. The information needed would be the type of obstacle, the ground coordinates, orientation of the obstacle, number of packages required and along which axis the packages are to be added. All additional information that is needed, such as obstacle dimensions, types of mines or demolitions, minefield density, manpower and equipment effort, and material and time requirements would be tabulated and stored internally as part of the program.

Appendix B (Obstacle Description and Standard Packages) contains discussion of each of the above mentioned obstacles, their characteristics, and the details of what constitutes a standard package for each.

V. ENGINEER MODEL

A. GENERAL

The system that is to be modeled is the interaction between the engineer forces and the available resources in the accomplishment of specific missions. These missions will be summarized into two general categories: the emplacement of obstacles and the breaching of obstacles. The accomplishment of either of these missions will constitute the events of the engineer simulation. This model will be used as a routine in the STAR model. The use of the model will be discussed in Chapter VI.

B. SYSTEM ENTITIES

1. Entities

The entities of the system will be:

- a. The engineer units/equipment
- b. The obstacle material
- c. The obstacles.

Each entity will have various attributes. Only those attributes of immediate interest are discussed below.

2. Engineer Units/Equipment

The basic element for combat engineering missions will be the squad. The basic element for performing construction tasks will be the individual pieces of construction equipment that are found in the headquarters of the platoon, company and battalion organizations. Each element will have

several attributes. One constant attribute will designate the force that the unit represents, either the U.S. or the Soviet force; another attribute will designate the size of the unit, that is, either a battalion, company, platoon or squad. Additionally, the element will have a changeable attribute which will indicate the status of the element. This attribute will change when the element is placed in an idle status after the completion of a mission or when the element is placed in a busy status upon assignment of a mission. Additionally, each element will have an attribute which will indicate the element's current position on the battlefield.

3. Material

There will be two attributes associated with this array. A constant attribute will indicate what kind of material is being represented in the model for use in the construction of obstacles. A changeable attribute will indicate the quantity of material on hand or available for use. Upon assignment of an obstacle for emplacement, the changeable attribute will be decremented by the amount of material required for the obstacle as specified in the standard package.

4. Obstacles

Obstacles also will require several attributes. A constant attribute will indicate the type of obstacle that is being represented. The changeable attributes, among other things, will indicate the status of the obstacle, location

and size. The status can be: scheduled for creation; created and unbreached; or created and breached.

C. SYSTEM BOUNDARY

1. Units

Since there are numerous types of engineer units, only those organizations which directly influence the main battle area will be modeled. Therefore, the U.S. forces which will be modeled at this time will be the divisional engineer battalion minus the mobile assault bridge (MAB) assets of the bridge company, and the corps combat engineer battalion. Likewise, the Soviet regimental engineer company and the divisional engineer battalion minus the pontoon bridge company and the amphibious company will be modeled. The divisional bridge assets are not included in the model. The modeling of a river crossing operation is a complicated procedure and is beyond the scope of this work.

2. Missions

As was stated earlier, the main area of concern is the battle in the brigade area. Therefore, the only missions which will be included in the system boundary will be the creation and the breaching of obstacles. The remaining missions that were discussed in Chapter II and special operations such as ADM and support of combat in the cities will not be included in this version of the engineer model.

D. RESOLUTION

1. Units and Equipment

As stated earlier, it is not uncommon for either a Soviet or an American engineer squad or item of equipment to be assigned an individual mission. For that reason, the level of resolution for the engineer forces must be at least to the squad level and major piece of equipment. However, the following convention will be used to limit the number of elements which will have to be represented in the model. The elements representing an engineer squad will include the personnel, the squad vehicle, the vehicle trailer and all the squad's assets such as tool sets, mine detectors and chain saws. Additionally, the element which represents an item of major equipment will include the operator of that piece of equipment. Since the bulldozer must be transported over long distances, the element representing the bulldozer will include the transport vehicle. The engineer squad loses its ability to perform any engineer mission if its squad vehicle is destroyed. Therefore, we can represent target acquisition of the engineer squad by detection of its vehicle. If the squad vehicle is destroyed, then the squad is eliminated. Since the engineer squad does not possess any heavy organic weapons, it is not capable of destroying enemy vehicles. The company headquarters and the headquarters platoon's equipment will be co-located with the supported brigade's headquarters.

The location of the platoon headquarters and the headquarters squad's equipment will be at the platoon's Forward Supply Point.

2. Obstacle Material

The obstacle material required for emplacement of a target will be bundled in standard packages for each type of target. That is, if a road crater is to be emplaced, a standard package of road cratering material will be released to the emplacing unit. The number of road cratering standard packages available will then be reduced by one. This will reduce the amount of bookkeeping required, as opposed to itemizing and keeping account of all the various types of materials such as blasting caps, time fuses and numerous different kinds of explosives.

3. Obstacles

Each obstacle that is emplaced must be represented in the model. The only time it would be appropriate to remove an obstacle from the system would be when it was completely breached and cleared. Since this is the mission of the follow-on echelons of engineers of both forces, which are not being represented, the obstacles will not be removed. In the case of aerial delivered mines, the mines can be preset to deactivate themselves after several days. However, since the battles that are being simulated will not be of that duration, the obstacles will remain active.

VI. ENGINEER ROUTINE

A. THE ENGINEER ROUTINE AS A PREPROCESSOR

In an extremely aggregate sense, all the scenarios can be divided into two categories which are the "first battle" and all subsequent battles.

1. First Battle

The term "first battle" is used to designate the initial conflict between the two opposing forces. In the NATO environment, this would equate to the initial battle planned for in the General Defense Plans (GDPs). Within the GDP there is the assumption that the defending force would have little or no notice up to as much as two weeks notice that a conflict is imminent. This time would be used to deploy forces and prepare battle positions. Some time during that period the authority to implement the obstacle plan would be given. At the time that initial conflict starts, the obstacle plan would be either partially or completely executed. Therefore, at the beginning of the first battle the prospective battlefield would contain obstacles.

2. Subsequent Battles

Subsequent battles are all other battles exclusive of the first battle. These battles may be fought on the same terrain as the first battle or on new terrain, depending upon whether the attackers succeeded in forcing the defenders to

withdraw or the defenders could successfully mount a counter-offensive operation. In either case, the battlefield would contain the unbreached obstacles from the first battle and the obstacles emplaced by the engineer forces since the first battle.

3. Initialization

Therefore, using either of the scenarios, the battlefield would normally contain obstacles. This fact means that some obstacles should be included in a battle simulation as an initial condition. This initialization of the battlefield can be accomplished by using the engineer routine as a pre-processor at the beginning of the simulation to generate the required obstacles. In other words, after the input data are read, but before the simulation begins, the engineer routine would be called.

B. WHAT THE ENGINEER ROUTINE WILL DO

The output or result of the routine will be a battlefield that is initialized with the appropriate obstacles. The obstacles that will be emplaced will be consistent with the manpower, material, and time resources that are available. This will be accomplished by taking the required missions, that is, the list of desired obstacles which specify the standard obstacle packages, as input and allocating the resources to accomplish these missions. A time of completion will be computed for each mission and only those

missions which have a completion time earlier than the start of the battle initially are created. All subsequent missions will be created upon their completion as the battle progresses. As obstacles are created the amount of resources available is decremented. The functioning of the engineer routine is depicted in Figure VI-1.

C. WHAT INPUT IS NEEDED

1. Mission Requirements

The selection of the obstacles to be emplaced and the order of emplacement are decisions the tactical commander must make. The commander's engineer staff officer provides the recommendations and expertise for obstacle employment, but the commander must insure that the obstacles support his tactical plan. It must be remembered that a minefield, for example, is an obstacle to both the attacking force as well as to a defender who is counterattacking or trying to withdraw across it. The commander decides where he needs to economize in force, canalize or stop the enemy. Therefore, the priority of obstacle emplacement is a decision which he makes and may impact directly upon the success of his plan.

The user, acting as the tactical commander, must input the mission requirements. The data required is a list in priority order of the obstacles to be emplaced. The list must include the ground coordinates of the obstacles, orientation of the obstacle from the east direction, and number

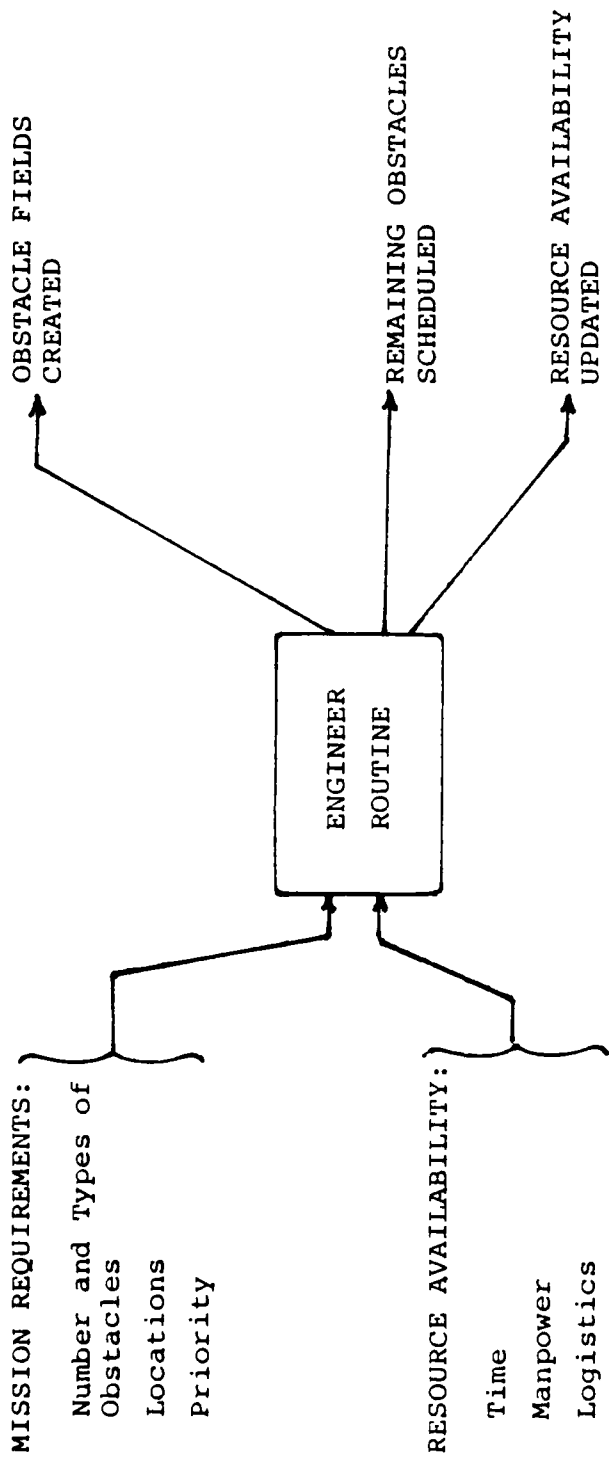

Figure VI-1. Schematic of the Engineer Routine.

of standard packages required. Additionally, two indicators are needed to designate along which axis the standard packages are to be added. Here "XDIR" will represent the number of packages to be added along the length of the obstacle and "YDIR" will represent the number of packages to be added along the width of the obstacle. An example of a mission requirement would be to emplace the following obstacle in a battalion sector. The desired obstacle is to be a road crater of twice the normal width across a road at the given coordinates. The road in this vicinity runs northeast to southwest. The requirement would be:

Type of obstacle:	road crater
Coordinates:	(given coordinates)
Orientation:	135 degrees
Standard packages:	2
XDIR:	0
YDIR:	1

2. Resources

The resources which need to be allocated to accomplish the missions are manpower or equipment, material and time. As was stated earlier, the allocation process can be simplified slightly by combining the manpower and equipment requirement. For example, if a bucketloader is needed to construct an anti-tank ditch, instead of allocating a bucketloader and then allocating the operator, the man and the

piece of equipment can be combined and allocated as a team. This will reduce some of the bookkeeping overhead and is justifiable since neither item, the operator or the equipment, is effective without the other.

a. Manpower

The available manpower will be a parameter that can be varied by the user. The normal allocation of divisional engineers is one company in support of each maneuver battalion. This arrangement will be the default condition, and can be varied in two ways. First, if the brigade commander, that is, the user, determines one battalion sector is more critical than another, he can shift the allocation of the engineers accordingly, by placing two or more platoons in support of one battalion and leaving one or more battalions without engineer support. Secondly, if the division receives a corps engineer battalion in support, it can supplement the brigade with additional engineer assets of section, platoon or company size. The user will be required to input the number of platoons that will be in support of each battalion if he decides to use this option. The element identification codes will be the same as those described in Appendix A.

b. Obstacle Material

In a normal GDP situation the engineer forces would deploy to their forward positions with their basic load of demolitions. The basic load is sufficient for one or two days worth of effort, which translates into emplacing five

to seven obstacles. Logistic resupply is pushed forward from the Ammunition Stockage Points (ASPs) to the units' or platoons' Forward Stockage Points (FSPs). The order and quantity of resupply is based initially upon the obstacle plan and the priority of emplacement. For example, if an engineer platoon's basic load is sufficient to emplace the first three priority targets in its supporting battalion's sector, then the first resupply it should receive would be the material that is required to emplace the fourth, fifth and sixth priority targets.

Thus the obstacle material can be played in different modes. First, if the first battle is being played, all obstacle material requirements have been preplanned and stocked in the rear areas. Therefore, under the assumption that the Transportation Plan - the plan designed to push supplies forward - is working, the materials would be arriving at the FSPs prior to their actual need, making the materials "available and unconstrained." This will be the default condition. Secondly, if the user desires to constrain certain obstacle material, he may do so by changing the default condition and altering the quantities of each item.

c. Time

There are two requirements for time, both of which will be user input. The first one is the time that the engineers will have available to work before the battle starts. If the user does not desire to specify a time, it will be set

at a default time of three days (72 hours). The second time requirement is to set a limit on the maximum number of hours that the men and equipment can be utilized in a twenty-four hour period. If the user declines to input a time, the value will be set at sixteen hours per day.

Continuing the example previously started, the routine must now allocate the appropriate resources to accomplish the task of emplacing the obstacle. First, a determination must be made by checking the list of obstacle material for quantities on hand. In this case, the assumption will be made that the material is available. Therefore, since two bundles of road-crater standard packages are needed, two bundles are decremented from the quantity on hand. The second determination that must be made is the availability of manpower/equipment. The standard package for a road-crater shows that one squad is required for one hour to emplace a single package, therefore a squad is needed for two hours to emplace the desired obstacle. A search of the squads assigned to that unit is made to determine which squad will be assigned the mission. The first squad found idle is given the task and its status is changed from idle to busy.

D. REQUIRED ROUTINES

The following routines are required to create the engineer routine, a routine to:

- a) Read the user or default input conditions on resource constraints and to make the required adjustments,

- b) Read the mission requirements, check for availability of resources, perform required calculations, and schedule the creation of the obstacle fields,
- c) To check feasibility in those missions scheduled for completion after the start of the battle,
- d) To replace manpower and equipment resources back into the "availability pool" upon completion of a mission.

1. Input Read Routine

a. Manpower

This routine will require that an additional identifier be assigned to each engineer element to indicate which maneuver battalion it is supporting. This identifier will be a user input.

b. Obstacle Material

The quantities of each obstacle standard package will be a user input.

c. Time

As stated earlier, two times are required as input. Both of these times, the allowable time for preparation before the battle begins and the maximum number of working hours per day, will be input parameters. These times can be changed by the user as he desires.

2. Obstacle Field Creation Routine

In the "The STAR Field Module," a technical report written by Professor James K. Hartman [2], two routines are presented for creation of obstacle fields for the STAR model. These routines are Routine FLD.INIT and Routine FLD.CREATE.

Both of these routines can be modified and used as the core routines for the preprocessor.

a. Routine FLD.INIT

This routine currently is called once by the main program before the start of the simulation. It reads the required missions and calls Routine FLD.CREATE to create all obstacle fields that are to be emplaced at the start of the battle. The routine can be changed to first check to insure that the proper resources are available for each obstacle before calling the create routine. If the resources are not available, the input data would be placed in a first-in, first-out (FIFO) queue. As resources become available in the future, the data are recalled to be checked for feasibility of emplacement at that time. In addition to checking resources, the routine would need to be modified to perform several calculations. If more than one standard package is used, a check is required to determine along which axis the packages are to be added. This will determine the semi-major and the semi-minor axis lengths of the ellipse which is used to represent the obstacle field in the simulation. The other calculation that is required will be to calculate the time it will take the emplacing element to move from its current location to the target location. This movement time plus the actual emplacement time is the time required to accomplish the mission.

b. Routine FLD.CREATE

Routine FLD.CREATE will need to be changed to a routine that would either create an obstacle field if the mission could be completed before the start of the battle or schedule the obstacle for creation at the appropriate time after the battle starts.

3. Feasibility of Mission Accomplishment

If an obstacle field is scheduled for creation after the start of the battle, a check for feasibility of mission accomplishment will need to be incorporated into Routine FLD.CREATE. This check would cancel the obstacle field creation if:

- a) The emplacing element was destroyed before the scheduled completion time, or
- b) If the enemy had closed to within a given range of the obstacle location before scheduled completion.

The cancellation of the field creation is required since either one of the above conditions would mean that the mission was not completed.

4. Replacement of Resources

Upon completion of a mission, the manpower and equipment resources must be placed back into the resources availability pool for future assignments. This requires that an additional check be made. First, before the resources are recycled, a check needs to be made to insure that the maximum number of work hours has not been exceeded. If that time has

been exceeded, the resources must be "rested" or kept unavailable for a specified period. At the end of that period the resources are set to idle and are available. Once additional resources become available, the FIFO queue holding those missions which were not scheduled due to lack of resources must be checked. If the appropriate resources are now available, the mission must be scheduled in accordance with the procedure described above.

5. Flow Charts

Flow charts of these modifications to the routines are shown in Appendix C.

VII. OBSTACLE ENCOUNTER

A. GENERAL

The purpose of an obstacle is to assist the defending force in the attrition of enemy forces by the disruption of the enemy's advance by causing him to stop, to turn to the flanks or to move into kill zones. Therefore it is the doctrine of both the U.S. and Soviet forces, that in order to maintain the momentum of advance, all obstacles should be bypassed as a first alternative and a breaching operation should be undertaken only if it is impossible or impractical to bypass. Once a breaching operation is begun, it must be completed quickly to allow the passage of the initial forces. The complete clearing of the obstacle is left for the follow-on units. The Soviets rely heavily on their advanced reconnaissance and OOD detachments to identify all obstacles along the planned advance route and to accomplish all required work to insure uninterrupted passage of forces. Based on this, obstacle encounter can be looked at in three phases:

1. Obstacle reconnaissance
2. Bypassing of an obstacle
3. Breaching of an obstacle

B. OBSTACLE RECONNAISSANCE

1. General

The results of accurate reconnaissance serve two purposes:

- a) Selection of column routes requiring the least amount of engineering preparation, and
- b) Planning the emplacement or positioning of the proper assets for any route clearing that may be required.

If both of the above are accomplished, then the amount of expected time delay during the march should be reduced. The following must occur in order to model the reconnaissance phenomena:

- a) Elements must be identified as the recon units.
- b) These units would need to be given preplanned routes to follow, and be deployed in advance of the march column.
- c) They would need the capability to determine or identify obstacle fields.
- d) They would need the capability to deviate from their routes to search for bypasses and alternative routes.
- e) Finally, they would need the capability to report this information to their higher headquarters.

The largest hindrance to the development of a routine which would allow reconnaissance is the lack of the ability to perform efficient, dynamic route selection. Dynamic route selection is needed to allow the recon elements to maneuver and search for bypasses and to allow the main column to change its route of march as dictated by the conditions of the battlefield. At this point the selection of an "optimum route" based on obstacle avoidance cannot be simulated easily. However, a bypass route can be generated around each obstacle by other means. This bypass route can be used to simulate the

marking of a bypass by the recon element. The amount of time it takes a unit to determine the bypass route will be a function of whether or not reconnaissance actually was accomplished. That is, if the reconnaissance was accomplished and a route was marked, a recon indicator would be set to a positive position and a unit encountering the obstacle would be given this route and the only time delay assessed against the unit would be the time it takes to traverse the route. On the other hand, if reconnaissance was not accomplished, the indicator would be in a negative position. Therefore, the unit would have to find its own bypass route and would be assessed a time delay until a route was found. The amount of delay would be added to the time it would take an element to traverse the route. Since the Soviets rely on reconnaissance for rapid advance, the indicator will be set to a positive position. The user must turn the indicator off if he does not desire to play reconnaissance even in this simple mode.

C. GENERATING A BYPASS ROUTE

An obstacle field that is generated by the Field Module [2] is elliptical in shape. The coordinates of the center of the field, the lengths of the semi-major and semi-minor axes, and the field orientation are known. The coordinates and the direction of movement of an element when it encounters a field are also known. Based on this information, a bypass can be generated around the obstacle.

1. Procedure and Calculations

The procedure and calculations required to do this are as follows:

a. First, a rectangle must be circumscribed about the ellipse, so that the longest side of the rectangle is parallel to the semi-major axis and tangent to the ellipse.

b. The coordinates of the corner points and equations of the lines representing the sides of the rectangle can be found by trigonometric means.

c. The distance from the point where the element entered the field to a side of the rectangle can be found by the method of projection; likewise, the coordinates of the point of intersection of this line with the side of the rectangle can be found.

d. The coordinates of the exit point, that is, the point where the element would exit the rectangle if it was allowed to continue through the field on a straight path, can be calculated.

e. The bypass route would then be from the point of entry on the field boundary to a side of the rectangle and along the boundary of the rectangle until the exit point is reached. At the exit point the direction of movement of the element would be reset to its original heading.

2. Bypass Algorithm

An algorithm can be developed to generate the bypass route as described. There will need to be several basic

checks and branches. The first condition that must be tested is the orientation of the field. The field can be oriented in two general ranges. They are from 0 to 90 degrees, and from greater than 90 to less than 180 degrees, measured from the east. Although the basic geometry of the fields and routes will be mirror images of each other, the coordinates of the corners and other reference points will be different. The next branching is required to determine the individual routes based upon the entry point into the field and direction of movement. This is required to determine to which side the projection must be made, and the first turning point on the route. The last check that must be made is to determine if the exit point is along the side of the rectangle to which the projection was made or if the element must proceed to one of the corners and then to the exit point. This can be done by choosing the minimum of the two distances from point B to either the exit point or the corner. An example of this procedure where both the orientation of the field and the angle of movement are less than 90 degrees is as follows:

a. Known information:

Coordinates of the center of the field:	(XC, YC)
Orientation of the field:	ANGLE
Semi-major axis length:	a
Semi-minor axis length:	b
Entry point of element (IP):	(XI, YI)
Angle of movement:	AM

The field and the bypass route are shown in Figure VII-1.

b. Information that must be calculated:

Coordinates of point B, the intersection
of the projection and the side of the
rectangle

Coordinates of the exit point (XE, YE)

Coordinates of the corners, C1 and C4

c. The calculations are as follows:

1) Coordinates of C1:

$$XC1 = XC - a \cdot (\cos(\text{ANGLE})) - b \cdot (\sin(\text{ANGLE}))$$

$$YC1 = YC - a \cdot (\sin(\text{ANGLE})) + b \cdot (\cos(\text{ANGLE}))$$

2) Coordinates of C4:

$$XC4 = XC - a \cdot (\cos(\text{ANGLE})) + b \cdot (\sin(\text{ANGLE}))$$

$$YC4 = YC - a \cdot (\sin(\text{ANGLE})) - b \cdot (\cos(\text{ANGLE}))$$

3) Distance from the entry point, IP to point B:

$$D = ((\tan(\text{ANGLE}) \cdot (XI - XC4)) + (YI - YC4)) / (1 + (\tan(\text{ANGLE}))^2)^{1/2}$$

4) Difference between the angle of movement and
the orientation of the field:

$$\text{ADIFF} = \text{AM} - \text{ANGLE}$$

5) Coordinates of point B:

$$XB = XI - (D \cdot (\cos(180 - \text{ADIFF})))$$

$$YB = YI - (D \cdot (\sin(180 - \text{ADIFF})))$$

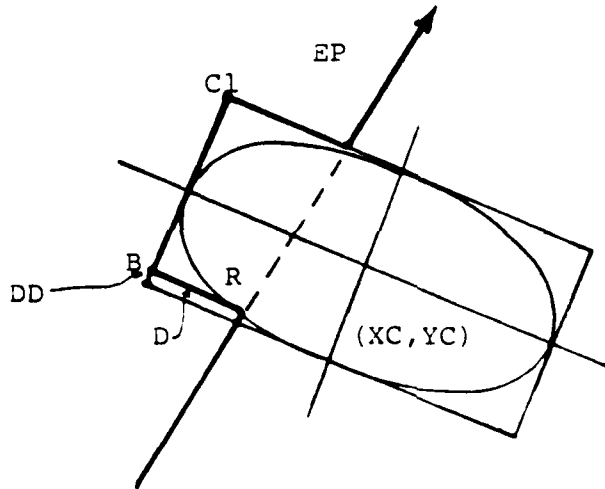
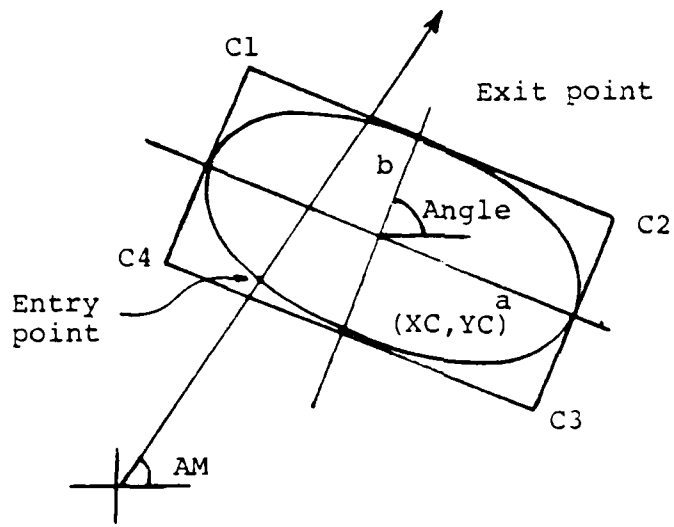

Figure VII-1. Obstacle field bypass.

6) Distance from point B to C4:

$$DD = ((XB - XC4)^2 + (YB - YC4)^2)^{1/2}$$

7) Distance from IP to exit point, EP:

$$R = ((2 b) - DD) \sin(ADIFF)$$

8) Coordinates of the exit point EP:

$$XE = XI + ((2 b - DD) \sin(ADIFF) \cos(ADIFF))$$

$$YE = YI + ((2 b - DD) \sin(ADIFF) \sin(ADIFF))$$

d. The sequence of moves would be:

- 1) Move from the entry point, IP, to point B
- 2) Move from point B to the corner, C1
- 3) Move from C1 to the exit point, EP
- 4) Return element to its original direction of movement by adding ADIFF to its current angle of movement
- 5) Release element to continue on its original path.

In this example, the direction of movement was from a southwesterly direction to a northeasterly direction. If the direction of movement was reversed and the element entered the field at the point which was determined to be the exit point, the projection would be made to the line C1 - C4 and the bypass route would be along that line to the corner C4 to the new exit point. The procedure shown in the example is valid for the following two cases:

1) $AM < 180$ degrees, and the coordinates of the entry point are

$$XI < XC - b \cdot (\cos(\text{ANGLE})) - 2 \cdot b \cdot (\cos(\text{ANGLE})/\tan(\text{ADIFF}))$$

and,

$$YI < YC - b \cdot (\sin(\text{ANGLE})) - 2 \cdot b \cdot (\sin(\text{ANGLE})/\tan(\text{ADIFF}))$$

2) $AM > 180$ degrees, and the coordinates of the entry point are

$$XI < XC + b \cdot (\cos(\text{ANGLE})) - 2 \cdot b \cdot (\cos(\text{ANGLE})/\tan(\text{ADIFF}))$$

and,

$$YI > YC + b \cdot (\sin(\text{ANGLE})) + 2 \cdot b \cdot (\sin(\text{ANGLE})/\tan(\text{ADIFF}))$$

D. BYPASSING THE OBSTACLE

As stated earlier, it is the doctrine of both forces, in general, to bypass obstacles. Bypassing is not appropriate when it will take longer to bypass than it would to breach; when it is suspected that by bypassing the unit will be canalized into a kill zone; or when a unit does not have permission from its higher headquarters to deviate from its assigned advance route.

1. Permission to Bypass

Each unit will need an additional changeable attribute which will be an indicator of whether the unit had permission to bypass or deviate from its route. The value of the indicator will be a user input. The permission to deviate from an assigned route will imply that the unit must return to that route as quickly as possible.

2. Breaching Versus Bypassing

A unit encountering an obstacle will have to decide on which course of action to take, that is, either to bypass or to breach. The alternative chosen will be the one that offers the least amount of time delay. As a general rule, the simplest of breaching operations, the positioning and the laying of an AVLB over a gap, will take longer than fifteen minutes. All other breaching operations will take longer. Therefore, if the time to bypass is less than this time, it will be the option that is selected. If the bypass time is greater, then the time to perform the breach must be found. This procedure will be discussed in the subsequent sections.

E. RISK OF CANALIZATION

In the preceding paragraph the assumption was made that the unit commander will choose the advance route that will minimize the unit's time delay. Therefore, the decision of whether to breach or bypass an obstacle based on the risk of being canalized into a kill zone will not be made.

F. BREACHING OF OBSTACLES

In general, most obstacles present a physical obstruction to the movement of a unit. For example, road craters and anti-tank ditches present a gap that must be crossed, while wire and abatis present a blockage that must be removed. Therefore, the breaching operation consists of determining a method to overcome the obstacle and then finding the assets

to accomplish that task, or knowing the available assets and determining an appropriate method of breaching using them. An encounter with a minefield has a third option - to bull a path through the field and accept the possible losses of equipment as the price for a lesser amount of time delay than if another method of breaching had been chosen.

Thus the sequence of a breaching operation is to determine:

- a. The type of obstacle field being encountered
- b. The possible methods of breaching compatible with the available assets
- c. If more than one alternative is available, then choose the method which minimizes time delay.
- d. If proper breaching assets are not within the unit, then the assets must be requested from the next higher headquarters and an additional time delay must be assessed while the unit awaits the arrival of assistance.

This breaching sequence can be simulated by the development of routines for each type of standard obstacle field. Here, the assumption is made that once a unit encounters an obstacle, it can identify it. That is, if a unit encounters a road crater, it can distinguish it from an anti-tank ditch and an abatis. Upon encountering an obstacle field, a routine for that type of obstacle will be called and a series of questions will be asked. The first question asked will be to determine if the unit has permission to bypass. If the answer is yes, then a check is made to determine if the recon indicator is on or off. If the indicator is on, then the bypass

routine is called and a route and time to traverse the route is generated. If the time to bypass is less than fifteen minutes, the unit will choose the bypass route and proceed along it. If the recon indicator is off or the time to bypass is greater than fifteen minutes, then the next set of questions will be to determine if the unit has the assets available to accomplish different types of breaches. The order in which the questions will be asked will be such that the technique which will minimize time delay is checked first. Once a method is found, the time to breach is compared with the time to bypass and again the minimum time is chosen. If a method of breach cannot be found, a request for assistance must be generated. This will consist of going to the next higher headquarters and checking the availability of equipment. If all the required items of equipment are busy, then the unit at the obstacle will choose the bypass route. If the equipment is available from higher headquarters, then a time of arrival of the equipment must be computed. If this time plus the time to breach is greater than the bypass time, then the bypass option is again chosen. If the total time is less than the bypass time, then a breach is scheduled to occur. One additional input requirement is needed for each unit, and that is an indicator of whether the unit has permission or the directive to breach minefields using the bull technique.

Flowcharts showing the breaching logic and various routines for each obstacle type are listed in Appendix D.

VIII. MEASURES OF EFFECTIVENESS

A. GENERAL

The measures of effectiveness that will be discussed will concentrate on the principal purposes of an obstacle which are to increase the amount of time the enemy is exposed and delayed, and to favorably change the force ratio for the defenders. The MOEs will be quantitative indicators of the obstacle's ability to accomplish its mission compared against a base case, that is, the battlefield void of obstacles.

B. BATTLE OUTCOME

The primary question of how an obstacle affects battle outcome is best answered by measuring casualties for each of the opposing forces. If the obstacles accomplish their designed missions, such as providing longer acquisition time and holding the attackers in the kill zones of the defenders' long range weapons and the defenders outside the range of the attackers' tank systems, there should be an increase in the number of survivors among the defenders (BLUE) and a decrease of survivors among the attacking force (RED). The MOEs are then:

- (1) NUMBER OF BLUE SURVIVORS / NUMBER OF BLUE STARTING
- (2) NUMBER OF RED SURVIVORS / NUMBER OF RED STARTING

The MOEs can include all of the forces' various elements or, depending on the scenario, the MOEs can be used to show the change in survivability of individual systems, such as tanks and infantry fighting vehicles.

If the obstacles are effective in supplementing the defenders' tactical plan, there should be an increase in the ratio of the BLUE forces and a decrease in the ratio of the RED forces as compared to the base case.

C. DELAY TIME

If it takes an attacking force a longer period of time to cross an area that contains an obstacle than the same area without one, it follows that crossing one or more obstacles could delay an attacking force from achieving its objective as originally planned. That implies that the longer it takes the attacker to gain its objective, the longer the defenders stay in their positions and are not forced to withdraw. This additional time could be used to accomplish tasks such as ammunition resupply and reinforcement of a unit.

In the STAR model there are two distinct criteria which determine when the defenders must withdraw from their position along a phase line to secondary or supplemental positions.

They are:

- a) Range to enemy force, or
- b) Combination of defender attrition level and RED/BLUE force ratio.

The first criterion is designed so that if the attacking force closes within a minimum distance (which is an input parameter for each of the weapon systems) that weapon system will either send a message to the next higher echelon of command requesting permission to move, or move of its own accord. The second criterion is designed to key a movement on a given attrition level of a weapon system or an unfavorable force ratio, which are input parameters.

Thus, if obstacles are effective in delaying and contributing to an increase in the attrition of the attackers:

- a) It should take longer for the attacker to reach the minimum range criterion, and
- b) The number of BLUE survivors should be higher,

thus postponing the movement decision due to attrition levels and likewise reducing the unfavorable force ratio. The term, "TIME OF FIRST SHOT," will be defined to be the time of the simulation when the first shot is fired at or by an element of the BLUE force. This will be the time that the battle actually begins. The term, "TIME TO MOVE," will be defined to be the time that a specific BLUE unit withdraws from its position. The size of the unit or type of element that would be monitored would be determined by the user. For example, the user could use as the TIME TO MOVE, the time that the first TOW section was withdrawn, or if he chooses, the time that the first platoon size unit was withdrawn. The MOE will be the difference of these two times. It is the time

from when the battle first begins until a unit withdraws.

The MOE is then:

(TIME TO MOVE) - (TIME OF FIRST SHOT).

IX. CONCLUSIONS AND RECOMMENDATIONS

The proposed structure of the engineer model represents a basic and simplistic view of the engineer forces on the battlefield. The model, when fully developed, will be focused on the defending engineer's key mission of obstacle emplacement and the opposing engineer's mission of obstacle reduction. Though the model is thus limited in scope, it captures the two most important functions of the engineer forces. The advantage these units present to the supported maneuver forces should be easily demonstrated. However, to more clearly see how the engineer forces can influence the battle, the following enhancements need to be made to the basic model once it is operational.

1. The idea of the standard package can be extended to other important engineer missions, specifically in the offense, the missions of position preparation and the construction of combat trails between positions need to be incorporated. In the defense, the mission of construction of unit positions and actions to be taken in support of the hasty defense need to be added.

2. The bypass generation routine will need to be modified. In reality, obstacles are tied into other obstacles or natural terrain features so that simple bypasses do not exist. Thus, this routine gives the unit encountering the obstacle field

an advantage in that it is not forced to cover a much longer distance in finding an alternate route around the construction.

3. As mentioned earlier, the Soviet forces depend heavily on reconnaissance to find, mark, and begin breaching operations of obstacles well before the main body arrives. Therefore, to play their tactics, a reconnaissance routine needs to be developed and incorporated into the STAR model.

4. If the brigade model is expanded to the division model, additional special engineer missions such as river crossing support and atomic demolition munitions missions need to be added.

APPENDIX A

ENGINEER UNIT ASSETS

A. U.S. DIVISIONAL ENGINEER BATTALION

1. HHC:	S-4 Section	Equipment Platoon
5-ton Dump Truck	6	-
Road Grader	-	4
Bulldozer	-	3
20-ton Crane	-	2
Pneumatic Trailer	-	1

2. LINE COMPANY:	Hq Platoon	Line Platoon (3)
APC	1	3
5-ton Dump Truck	1	1
CEV	2	-
Bulldozer	1	-
Pneumatic Trailer	1	-
Scooploader	-	1
Electric Tool Trailer	-	1
Chainsaw	-	3
Mine Detectors	2	6

3. BRIDGE COMPANY

Interior MAB Bays	16
End MAB Bays	8
20-ton Cranes	1
AVLB Carriers	4
AVLB Bridges	6
Bulldozer	1
15-Man Assault Boats	18
LTR sets	2

B. U.S. CORPS ENGINEER BATTALION:

1. HHC:	S-4 Section	Equipment Platoon
5-ton Dump Truck	6	4
Road Grader	-	4
Bulldozer	-	2
Scooploader	-	2
20-ton Crane	-	3
Sheepsfoot Roller	-	1
Vibrating Roller	-	1
Skid Mounted Auger	-	1
Pneumatic Trailer	-	1
Mine Detectors	-	10

2. LINE COMPANY:	Hq Platoon	Line Platoon (3)
5-ton Dump Truck	1	4
Bulldozer	2	-
Pneumatic Trailer	1	-
Scooploader	-	1
Electric Tool Trailer	-	1
Chainsaws	-	3
Mine Detectors	2	7

C. SOVIET REGIMENTAL ENGINEER COMPANY:

	Combat Engineer Platoon	Bridge Platoon	Technical Platoon
APC	3	-	-
Minelaying Trailers	3	-	-
Truck Launched Scissor Bridge	-	4	-
Tank Launched Cantilever Bridge	-	1-3	-
Tractor Dozer	-	-	1
Trencher	-	-	1
Crane	-	-	2
Bucket Excavator	-	-	1

D. SOVIET DIVISIONAL ENGINEER BATTALION:

1. COMBAT ENGINEER COMPANY:	Combat Platoon (3)	Mine Laying Platoon	
APC	3	-	
Carrier w/Mineclearing Equipment	3	-	
Vehicle Mounted Mine Detector	2	-	
Armored Tracked Minelayer	-	3	
Minelaying Trailers	-	3	
2. TECHNICAL COMPANY:	Bridge Platoon	Road Constr. Platoon	Position Prep. Platoon
Truck Launched Scissor Bridge	4	-	-
Tank Launched Cantilever Bridge	3	-	-
Tractor Dozer	-	6	-
Crane Shovel	-	2	-
Armored Engineer Vehicle	-	2	-
Grader	-	2	-
Wheeled Dozer	-	2	-
Trencher	-	-	2
Ditcher	-	-	2
3. PONTOON BRIDGE COMPANY:			
Folding Pontoon Bridge	18		
Power Boats	6		
4. AMPHIBIOUS COMPANY:	Tracked Amphib- ious Platoon	Ferry Platoon	
Tracked Amphibian Carriers	10	-	
Self-Propelled Ferry	-	6-12	

E. WEAPON/SYSTEM CODES: The following designations are the Weapon/System codes for the Engineer forces:

<u>System Code</u>	<u>Weapon Code</u>	<u>Element Type</u>
2	1	U.S. Engineer Squad Vehicle
	7	BMP w/Minelayer
	9	BMP w/Mineclearer
9	1	U.S. CEV
	2	Scooploader
	3	Dozer
	4	Dump Truck
	5	Crane
	6	Grader
	7	AVLB
	12	Soviet Armored Engineer Tractor
	13	Bucket Excavator
	14	Dozer Tractor
15	Crane Shovel	
16	Tank Launched Cantilever Bridge	
17	Truck Mounted Scissor Bridge	
9	18	Trencher
	19	Vehicle Mounted Mine Detector

F. ELEMENT IDENTIFICATION: The following charts display the input requirement for various Engineer forces. The format shown is the format required by the STAR model. The numbering sequence used as the "name" for each element was arbitrarily chosen for the purpose of illustration. The actual numbering of elements will be sequential, starting with the first number following the last BLUE maneuver element for the BLUE Engineer forces, and the first number following the last RED maneuver element for the RED (Soviet) Engineer forces.

(1) U.S. DIVISIONAL ENGINEER BATTALION:

(a) LINE PLATOON OF A LINE COMPANY:

Name	System Type	Weapon Type	Section	Platoon	Company	Battalion	Section Leader	Platoon Leader	Start Area
11	2	1	1	1	1	*	11	14	**
12	2	1	2	1	1		12	14	
13	2	1	3	1	1		13	14	
14	9	8	4	1	1		14	14	
15	9	4	5	1	1		15	14	
16	9	2	6	1	1		16	14	

(b) HQ PLATOON OF A LINE COMPANY:

29	2	1	1	4	1	*	29	29	**
30	9	4	2	4	1		30	29	
31	9	3	3	4	1		31	29	
32	9	1	4	4	1		32	29	
33	9	1	5	4	1		33	29	

(c) BRIDGE COMPANY:

79	9	5	1	1	5	*	79	85	**
80	9	3	2	1	5		80	85	
81	9	7	3	1	5		81	85	
82	9	7	4	1	5		82	85	
83	9	7	5	1	5		83	85	
84	9	7	6	1	5		84	85	
85	9	8	7	1	5		85	85	

(d) HHC:

86	9	4	1	1	6	*	86	86	**
87	9	4	2	1	6		87	86	
88	9	4	3	1	6		88	86	

* : To be based on number of battalions being simulated by user.
** : To be determined by user.

(d) HHC (continued)

Name	System Type	Weapon Type	Section	Platoon	Company	Battalion	Section Leader	Platoon Leader	Start Area
89	9	4	4	1	6	*	89	86	**
90	9	4	5	1	6		90	86	
91	9	4	6	1	6		91	86	
92	9	6	7	2	6		92	92	**
93	9	6	8	2	6		93	92	
94	9	6	9	2	6		94	92	
95	9	6	10	2	6		95	92	
96	9	3	11	2	6		96	92	
97	9	3	12	2	6		97	92	
98	9	3	13	2	6		98	92	
99	9	5	14	2	6		99	92	
100	9	5	15	2	6		100	92	

(2) U.S. CORPS ENGINEER BATTALION:

(a) LINE PLATOON OF A LINE COMPANY:

101	9	4	1	1	1	*	101	104	**
102	9	4	2	1	1		102	104	
103	9	4	3	1	1		103	104	
104	9	8	4	1	1		104	104	
105	9	4	5	1	1		105	104	
106	9	2	6	1	1		106	104	

(b) HQ PLATOON OF A LINE COMPANY:

119	9	8	1	4	1	*	119	119	**
120	9	4	2	4	1		120	119	
121	9	3	3	4	1		121	119	
122	9	3	4	4	1		122	119	

(c) HHC:

Name	System Type	Weapon Type	Section	Platoon	Company	Battalion	Section Leader	Platoon Leader	Start Area
167	9	4	1	1	5	*	167	167	**
168	9	4	2	1	5		168	167	
169	9	4	3	1	5		169	167	
170	9	4	4	1	5		170	167	
171	9	4	5	1	5		171	167	
172	9	4	6	1	5		172	167	
173	9	4	1	2	5		173	173	
174	9	4	2	2	5		174	173	
175	9	4	3	2	5		175	173	
176	9	4	4	2	5		176	173	
177	9	6	5	2	5		177	173	
178	9	6	6	2	5		178	173	
179	9	6	7	2	5		179	173	
180	9	6	8	2	5		180	173	
181	9	3	9	2	5		181	173	
181	9	3	10	2	5		182	173	
182	9	5	11	2	5		183	173	

(3) SOVIET REGIMENTAL ENGINEER COMPANY:

(a) COMBAT ENGINEER PLATOON:

200	2	7	1	1	1	*	200	200	**
201	2	7	2	1	1		201	200	
202	2	7	3	1	1		202	200	

(b) BRIDGE PLATOON:

203	9	17	1	2	1	*	203	203	**
204	9	17	1	2	1		203	203	
205	9	17	1	2	1		203	203	
206	9	17	1	2	1		203	203	
207	9	16	2	2	1		207	203	
208	9	16	2	2	1		207	203	
209	9	16	2	2	1		207	203	

(c) TECHNICAL PLATOON:

Name	System Type	Weapon Type	Section	Platoon	Company	Battalion	Section Leader	Platoon Leader	Start Area
210	9	14	1	3	1	*	210	210	**
211	9	18	1	3	1		210	210	
212	9	15	1	3	1		210	210	
213	9	15	1	3	1		210	210	
214	9	13	1	3	1		210	210	

(4) SOVIET DIVISIONAL ENGINEER BATTALION:

(a) LINE PLATOON OF A LINE COMPANY:

215	2	9	1	1	1	*	215	215	**
216	2	9	2	1	1		216	215	
217	2	9	3	1	1		217	215	
218	9	19	4	1	1		218	215	
219	9	19	5	1	1		219	215	

(b) MINELAYING PLATOON OF A LINE COMPANY:

230	2	7	1	4	1	*	230	230	**
231	2	7	1	4	1		230	230	
232	2	7	1	4	1		230	230	

(c) BRIDGE PLATOON OF THE TECHNICAL COMPANY:

233	9	17	1	1	2	*	233	233	**
234	9	17	1	1	2		233	233	
235	9	17	1	1	2		233	233	
236	9	17	1	1	2		233	233	

(d) ROAD CONSTRUCTION PLATOON OF THE TECHNICAL COMPANY

237	9	14	1	2	2	*	237	237	**
238	9	14	1	2	2		237	237	
239	9	14	1	2	2		237	237	
240	9	14	1	2	2		237	237	
241	9	14	1	2	2		237	237	

(d) ROAD CONSTRUCTION PLATOON OF THE
 TECHNICAL COMPANY (continued)

Name	System Type	Weapon Type	Section	Platoon	Company	Battalion	Section Leader	Platoon Leader	Start Area
242	9	14	1	2	2	*	237	237	**
243	9	15	1	2	2		237	237	
244	9	15	1	2	2		237	237	
245	9	12	1	2	2		237	237	
246	9	12	1	2	2		237	237	
247	9	18	1	2	2		237	237	
248	9	18	1	2	2		237	237	

APPENDIX B

OBSTACLE DESCRIPTION AND STANDARD PACKAGES

1. Minefields

Minefields are classified into five types as follows: protective, point, tactical, interdiction, and phony.

a. Protective Minefields

Protective minefields are used as part of a unit's close-in protective defense. The unit that lays the minefield, which need not be an engineer unit, is responsible for removal of it upon departure from the area. For that reason, only metallic mines are used for ease of location and anti-handling devices are not attached to the mines for ease of removal.

b. Point Minefields

Point minefields are normally irregular in size and are used to supplement other obstacles, such as mining a road crater or the immediate area around an abatis. These minefields also are used at specific points, hence their name, to counter enemy mobility. Examples of this are the mining of possible fording sites or a specified crossroad along a likely avenue of approach.

c. Tactical Minefields

Tactical minefields are developed to supplement the overall tactical plan. They are typified by being laid to a standard pattern, having a specific density and a

specific mission. They are tied in directly to the division or brigade plan. Their emplacement is usually a high priority.

d. Interdiction Minefields

Interdiction minefields are planned and executed by corps beyond the range of organic division weapons to cause harassment and disruption of operations behind enemy lines.

e. Phony Minefields

Phony minefields are used to deceive the enemy as to the location of real obstacles and to extend the boundaries of live minefields.

The types of minefields for the engineer model will be restricted to the point and tactical. Point minefields which supplement other obstacles will be included in that obstacle's standard package and not as a separate entity. Likewise, all other point minefields will be treated as tactical minefields.

f. Means of Emplacement

Currently, minefields can be emplaced by several methods which are: by hand, by truck-towed M-57 mine dispensing system, by helicopter M-56 mine dispensing system, and by artillery. A standard package will be developed for each.

g. Standard Packages

The standard packages for the various minefields are listed in the following table.

2. Road Craters

Road craters are obstacles which sever roadways, making them impassable without some breaching effort to wheeled and tracked vehicles. This type of obstacle can be created by standard road cratering demolitions, by prechambered demolitions or by the M180 cratering device.

a. Standard Road Cratering Demolitions

Currently, this is the most commonly used method of cratering. It requires several stages to complete the obstacle and is both time and manpower consuming, especially as you progress from a single lane dirt road to a multi-laned, reinforced autobahn. The procedure is first, to create holes in the road surface 5' to 7' deep by using shaped charges. The holes are then widened and cleared of debris. This process is usually accomplished by using hand tools. The cratering charges are then placed in the holes and set off. The resulting crater is approximately six meters wide and three meters deep. It extends about one meter past the roadway on either side.

b. Prechamber

Prechambered road craters are found only in the Federal Republic of Germany. As their name implies, they are chambers that are prepared in the roadway at critical points.

TABLE I

MINEFIELD STANDARD PACKAGES

<u>TYPE</u>	<u>AT</u>	<u>AT-AP</u>	<u>AT</u>	<u>AP</u>	<u>AT-AP</u>	<u>AT-AP</u>
Emplacement	M56	Artillery	Artillery	Artillery	M57	Hand
Identifier	11	12	13	14	15	16
Length (meters)	100	250	250	250	50	100
Width (meters)	20	250	250	250	50	100
Height (meters)	NA	NA	NA	NA	NA	NA
Density (mine/sq. meter)	0.0266	0.001/.0005	0.001	0.001	0.002/.002	0.002/.002
Time (hours)	0.75	0.03	0.03	0.015	1.0	2.0
Manpower/ Equipment	Helicopter	1 Battery	1 Battery	1 Battery	1 Truck	3 Squads

Notes: AT: Anti-tank

AP: Anti-personnel

0.001/.0005: Density of AT mines/AP mines

A prechambered target usually consists of three to five chambers set diagonally across the road surface. The target is activated by removing the chamber covers and filling the holes with special demolitions. Most prechambers already have the firing circuit emplaced and run to a firing control box. Thus the target can be armed and executed quickly. The disadvantage of the prechambered target is that its location is fixed and cannot be moved. Even though they usually are sited at critical places based solely on terrain features, they may be difficult to tie in directly with the tactical plan.

Since the locations of the prechambers are fixed, the user of the STAR model should be given the option of using several prechambered targets. The location of these targets will be fixed and based on terrain.

c. M180 Cratering Device

The M180 cratering device is a new system that is currently being fielded. It consists of a tripod on which is mounted a shaped charge and a cratering charge that is driven by a rocket motor. The device compensates for a lack of prior preparation of the cratering site, thus saving time and labor. A road crater can be executed by a squad of men using five devices in one hour. That time is equivalent to the time it would take to execute a prechambered target and one-half the time it would take using standard demolitions.

The standard packages for these obstacles are listed in the following table:

TABLE II
ROAD CRATER STANDARD PACKAGES

<u>TYPE EMPLACEMENT</u>	<u>ROAD CRATER STANDARD</u>	<u>ROAD CRATER PRECHAMBER</u>	<u>ROAD CRATER M180</u>
Identifier	21	22	23
Length (meters)	10	15	10
Width (meters)	6	12	6
Height/Depth (meters)	2.6	7.0	2.6
Density/Mines	6 M21	NA	6 M21
	6 M18A1	NA	6 M18A1
Time (hours)	2	1	1
Manpower/ Equipment	1 Squad	1 Squad	1 Squad

3. Bridge Demolition

The term "bridge demolition" will be used to mean the complete destruction of a bridge structure. This destruction will be accomplished by cutting the span at each of its ends. If a bridge is a multi-span structure and the span to be cut is less than 30 feet long, making the gap breachable by an armored vehicle launched bridge, at least one additional span will have to be cut. For bridge demolitions, the standard packages do not represent different methods of creating an obstacle, but rather the demolition of different types of bridge structures. For example, the

packages contrast the destruction of a steel stringer bridge against a concrete beam bridge. The standard packages are listed in Table III.

TABLE III
BRIDGE DEMOLITION STANDARD PACKAGES

<u>TYPE OF BRIDGE</u>	<u>MAJOR 4-LANE HIGHWAY</u>	<u>PRIMARY 2-LANE HIGHWAY</u>	<u>SECONDARY 2 LANE</u>
Emplacement Means	200 lbs. C-4	180 lbs. C-4	50 lbs. C-4
Identifier	31	32	33
Length (meters)	NA	NA	NA
Width (meters)	33	16	10
Depth (meters)	NA	NA	NA
Density of Mines	12 M15 12 M16	6 M15 6 M16	6 M15 6 M16
Time (hours)	3	2	1
Manpower/ Equipment	1 Squad	1 Squad	1 Squad

4. Log Obstacles

The log obstacles commonly found and described in the literature are: log cribs, log hurdles, log posts and abatis.

a. Log Cribs

Log cribs are constructed across a roadway and perpendicular to the direction of traffic. They consist of

two log walls approximately 1.5 meters high and 2 meters apart. The walls are cross braced together on the ends and in between. The area between the walls is then filled with soil and compacted. The obstacle is usually booby-trapped with anti-personnel mines to hinder breaching by hand tools. The obstacle can be quickly reduced or breached by a demolition or by demolition gun.

b. Log Hurdle

Log hurdles are three sets of logs placed at oblique angles to each other in a staggered pattern along the direction of travel of a road. Each set of logs is 40-50 cm high. The purpose of the obstacle is to slow vehicle movement by forcing the vehicles to successively climb over the hurdles. Tracked vehicles find it extremely difficult to negotiate the staggered pattern and scale the vertical height of the logs simultaneously, the result being that a track may be thrown, thus temporarily immobilizing the vehicle.

c. Log Posts

A log post obstacle is a series of rows of log posts that are set vertically in the ground across the roadway. The distance between posts is fixed so that vehicles cannot pass in between two adjacent posts. The posts in the successive rows are staggered so that a post is centered between two posts of the row in front of it.

d. Abatis

An abatis is created by felling trees along a roadway in such a way that the trees are not separated from the stump and fall in a criss-cross pattern across the road facing the enemy. The obstacle should be about 40 meters long and is usually booby-trapped with anti-personnel mines. The obstacle is simple to construct and time consuming to breach.

The first three log obstacles discussed are simple to construct and are easy to breach. Based on the amount of effort that is required to emplace them and the small delay that they would generate, they should not be considered for inclusion in the STAR model. The resources that they consume, especially time, could be more effectively used in emplacing other or different types of obstacles.

The standard package for the abatis is listed in Table IV.

5. Wire

Wire is an effective obstacle against dismounted infantry and, if employed in depth, against vehicles. Wire can be employed in numerous configurations. The three that will be included in the STAR model are: general purpose barbed tape, triple standard concertina, and the concertina roadblock.

a. General Purpose Barbed Tape (GPBT)

The GPBT obstacle consists of three coils of GPBT placed side by side for a length of 300 meters, and anchored

in place by the staples that come as part of the system. The obstacle is extremely effective against dismounted infantry. It can be breached by numerous means including demolition by bangalore torpedoes. However, to prevent the canalization of the attackers, the wire would need to be breached in several locations.

b. Triple Standard Concertina

The triple standard concertina obstacle consists of two coils of concertina wire placed side by side with a third coil placed on top. The length of the obstacle is 300 meters. Pickets are driven into the ground at set intervals to anchor the wire. Like the GPBT obstacle, concertina is effective against dismounted personnel but can be breached by numerous techniques.

c. Concertina Roadblock

A concertina roadblock consists of 11 coils of concertina placed side by side and across the road surface perpendicular to traffic flow. Each coil is held in place by pickets and a strand of GPET. The length of the obstacle is 10 meters and is effective in impeding vehicle movement.

The standard packages for the wire obstacles are listed in Table V.

6. Anti-Tank Ditch

An anti-tank ditch is a linear obstacle that is used to stop or canalize tracked vehicles. There are several different ditch cross sections which all require about the same

amount of construction effort. The soil to be excavated is assumed to be clay. The standard packages for anti-ditches contrast the construction of the obstacle by different types of equipment and are listed in Table IV.

TABLE IV
 ABATIS AND ANTI-TANK DITCH STANDARD PACKAGES

<u>TYPE</u>	<u>ABATIS</u>	<u>AT DITCH</u>	<u>AT DITCH</u>
Emplacement	Chainsaw/ Demolitions	2 Dozers	1 Dozer 1 Scooploader
Identifier	51	61	62
Length (meters)	40	100	100
Width (meters)	4	4	4
Depth (meters)	NA	2	2
Density/Mines	10 M18A1	NA	NA
Time (hours)	2	1	1
Manpower/ Equipment	1 Squad	2 Dozers	1 Dozer 1 Scooploader

TABLE V
WIRE OBSTACLE STANDARD PACKAGES

<u>TYPE</u>	<u>BARBED TAPE</u>	<u>CONCERTINA</u>	<u>ROADBLOCK</u>
Emplacement	By Hand	By Hand	By Hand
Identifier	41	42	43
Length (meters)	300	300	10
Width (meters)	3	6	10
Height (meters)	1	1.75	1
Density/Mines	NA	NA	NA
Time (hours)	1	1	1
Manpower/ Equipment	1 Squad	1 Squad	1 Squad

APPENDIX C

FLOW CHART OF MODIFICATIONS TO FLD.INIT

1. This appendix contains the flow chart of the proposed modifications to routine FLD.INIT.

2. Expansion/Clarification of Flow Chart Blocks:

Decision block "IF QUANTITY OF MATERIAL < PACK": is the comparison of the number of standard packages of a type of obstacle that is required for obstacle emplacement against the quantity of packages on hand, as listed in array MATERIAL.

Decision block "IS MANPOWER/EQUIPMENT AVAILABLE": is a check to see if the manpower/equipment assets as specified in the obstacle standard package are available, that is, are they idle.

Process block "DETERMINE DISTANCE FROM UNIT TO FIELD": the distance from the unit's current position to the proposed field location is measured along a straight line; the time to move between these locations is found by dividing the distance by the unit's vehicle speed.

3. The flow chart follows.

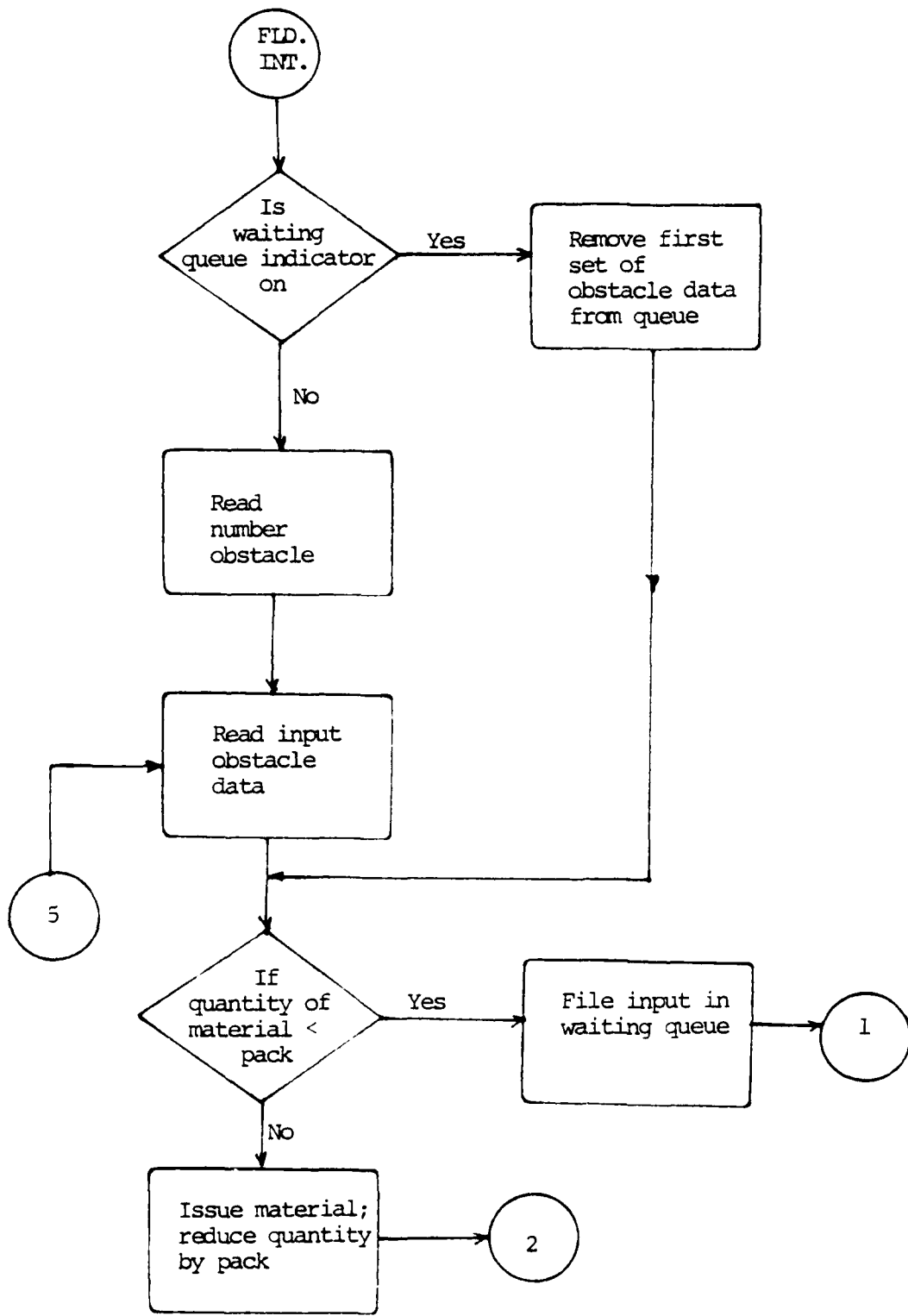

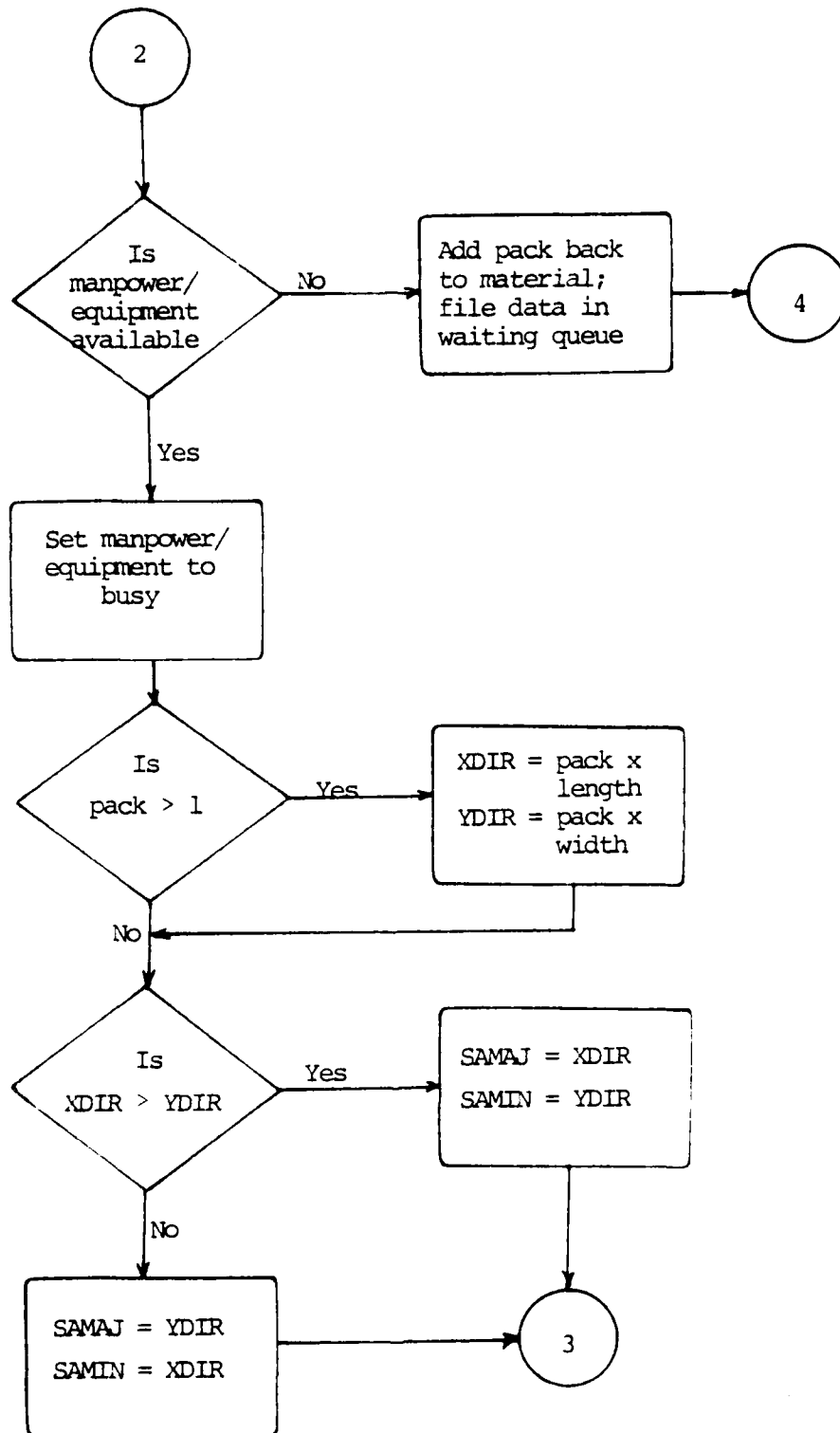

51

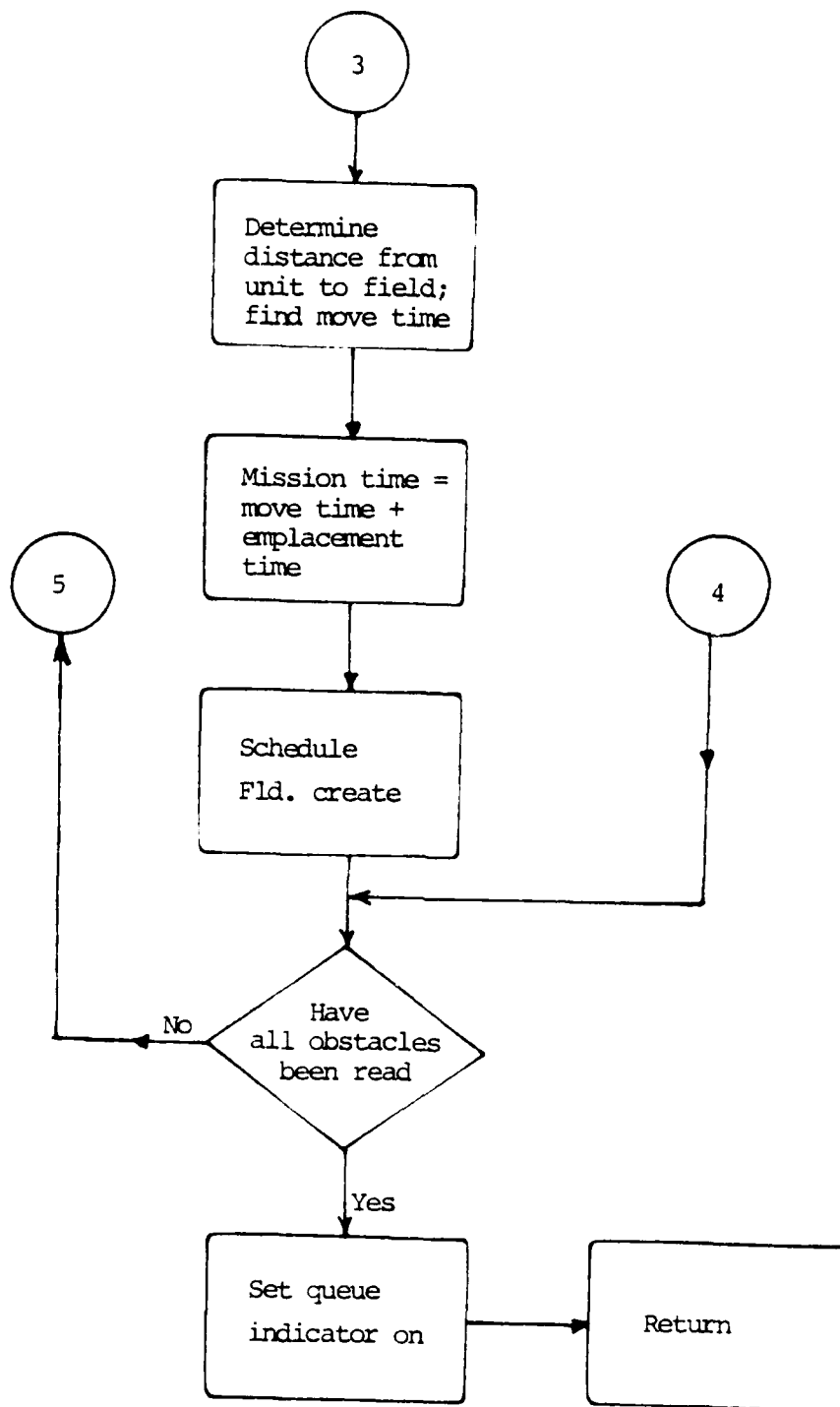

APPENDIX D

FLOW CHARTS OF BREACHING LOGIC

1. This appendix contains the flow charts for the basic breaching logic for the proposed standard obstacles. The breaching techniques listed are not exhaustive, but are the techniques most commonly used. The techniques are presented in the order which is least costly in time to accomplish.

2. Expansion/Clarification of Flow Chart Blocks:

If the "permission to bypass" indicator is off, then the time to bypass is set to a "large" number, thus forcing a breaching operation.

For clarity of the flow charts, the check to see if higher headquarters has the required breaching assets if the subordinate unit did not, has been omitted. This check would occur after the check of the last breaching technique failed.

The question asked on whether the unit had the proper equipment to accomplish the breach has been phrased so as to reflect U.S. equipment. In the actual algorithm, the question will be asked about the U.S. item or the Soviet counterpart item.

Decision block "IS THE TIME TO BREACH > TIME TO BYPASS": In all cases, the time to breach will be the time it will take to breach a standard or multiple standard obstacle

using the technique being checked. Thus, for each decision block the breach time will be different.

3. The flow charts are as follows.

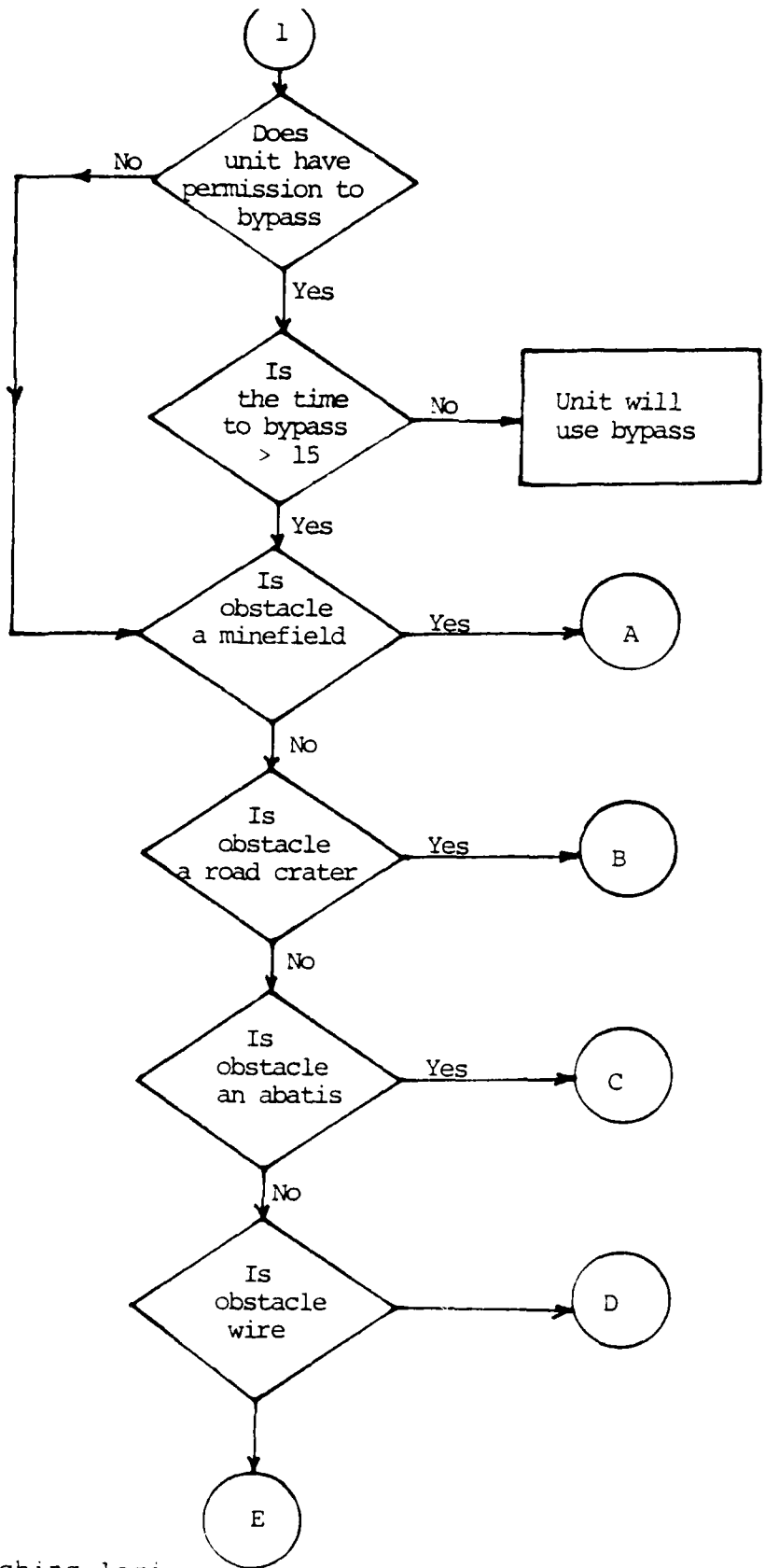

Basic breaching logic.

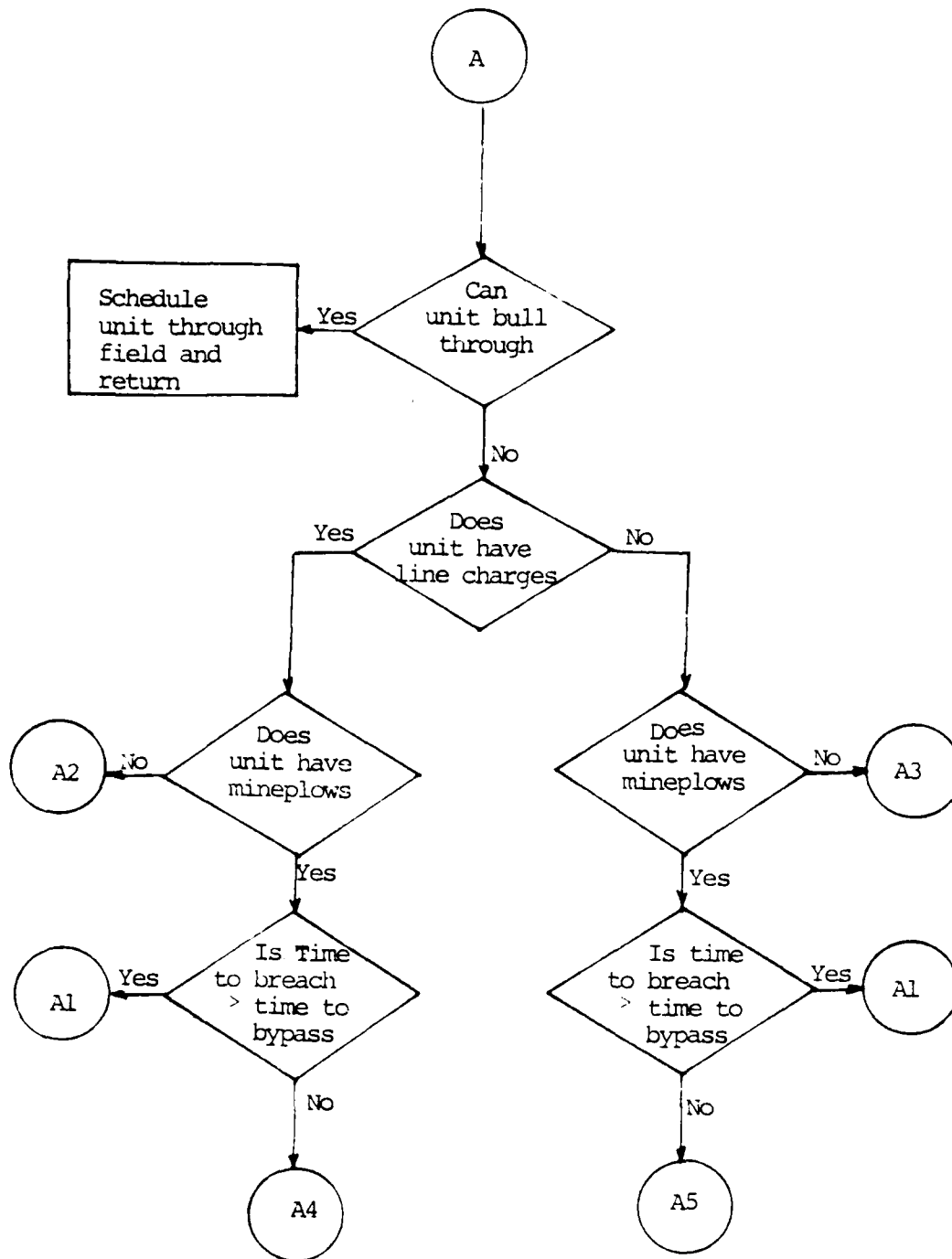

Breaching of a minefield.

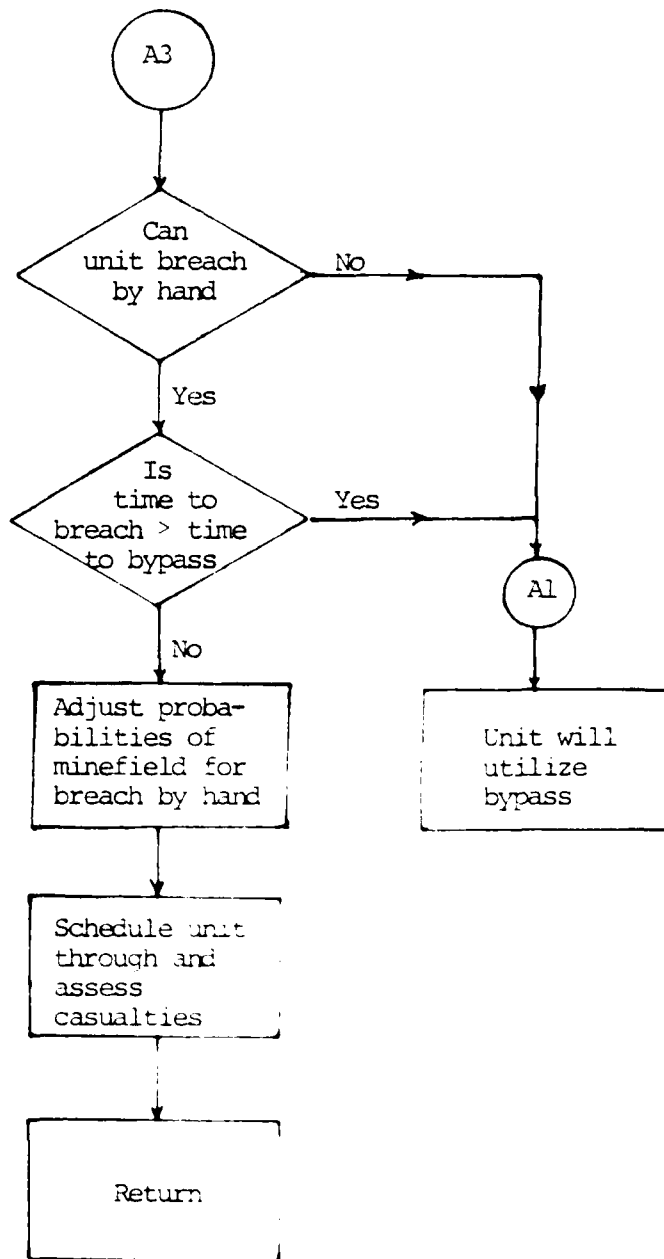

Breaching of a minefield (continued).

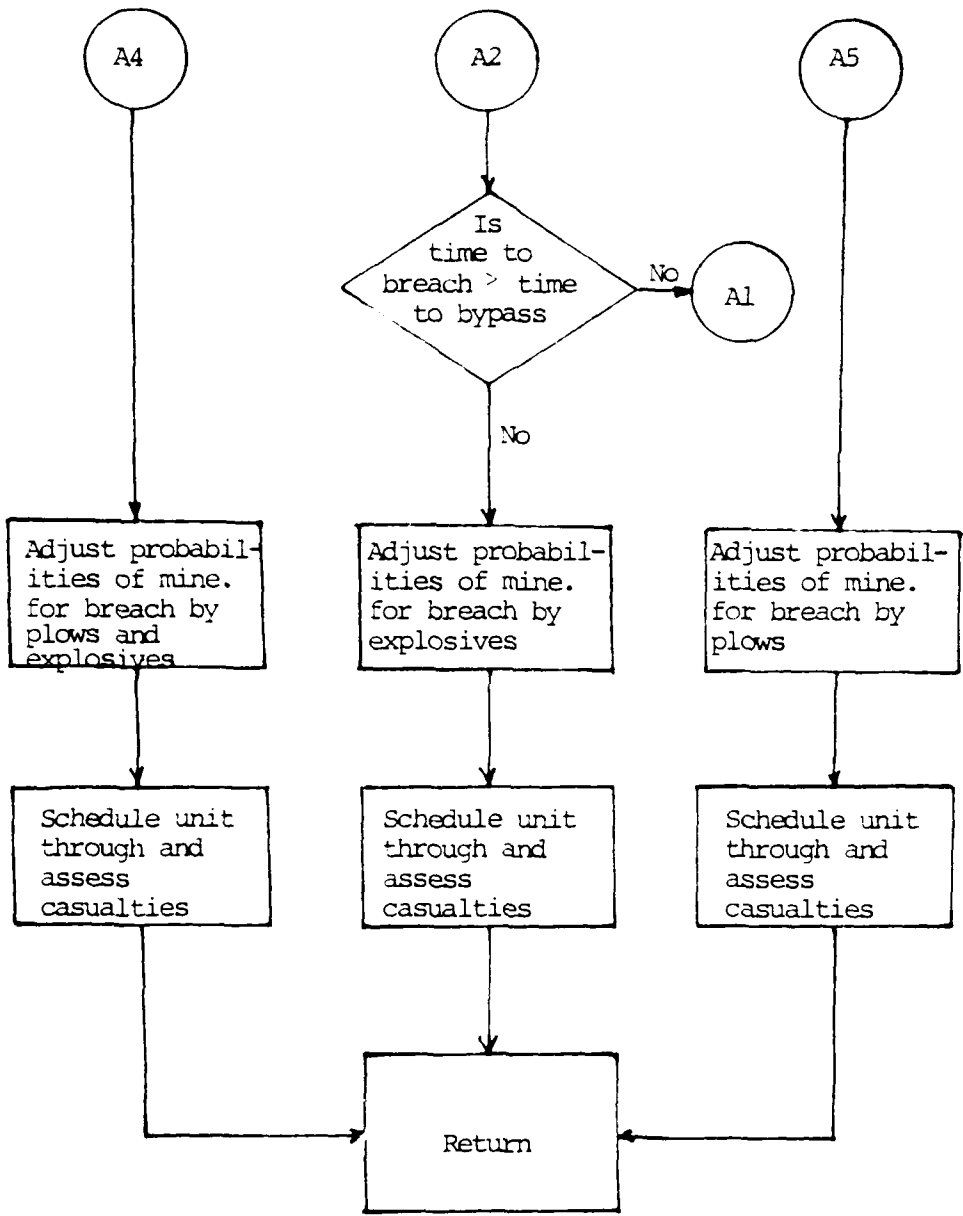

Breaching of a minefield (continued).

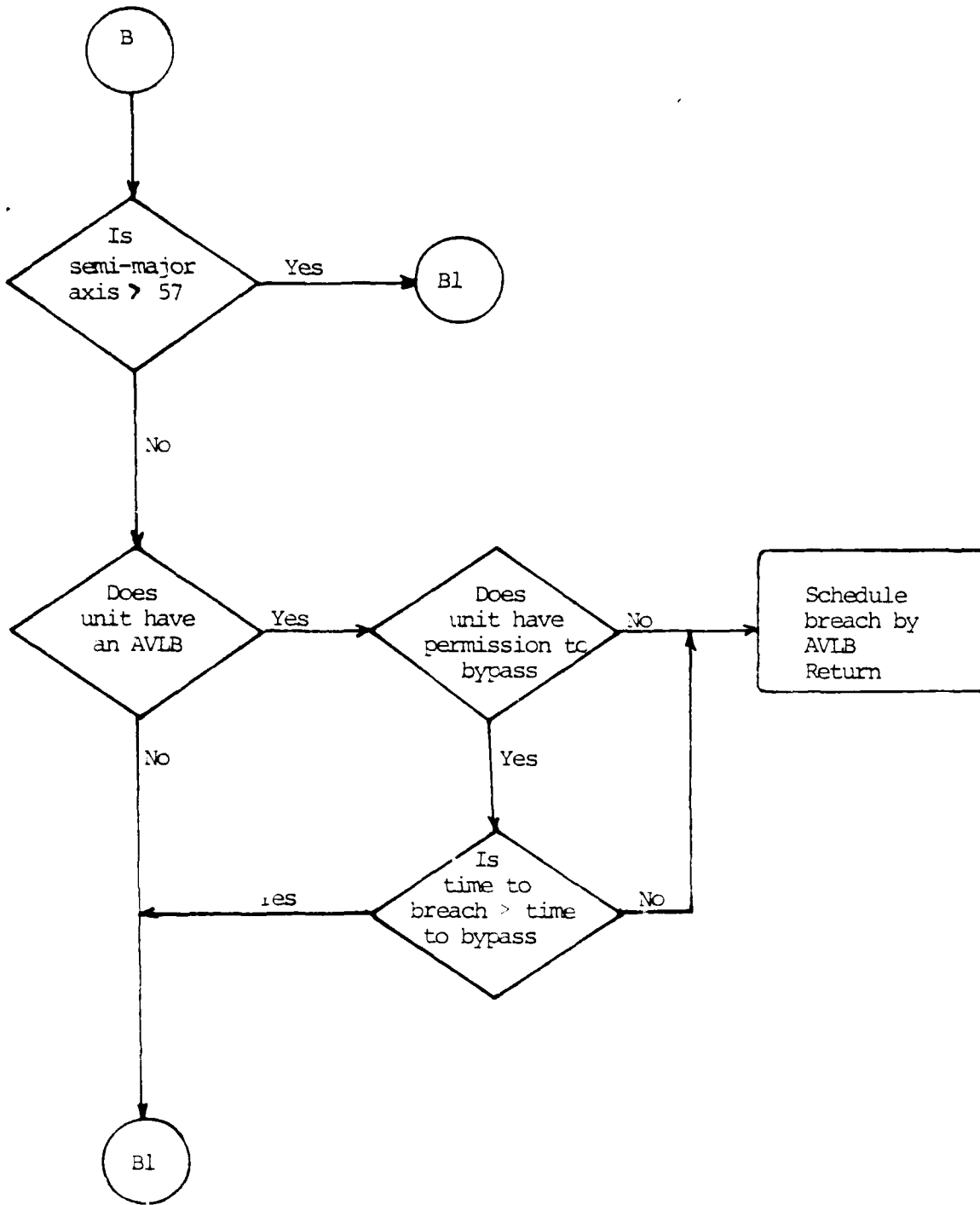

Breaching of a road crater.

AD-A097 290

NAVAL POSTGRADUATE SCHOOL MONTEREY CA
A STRUCTURE FOR THE DEVELOPMENT OF AN ENGINEER MODEL. (U)
DEC 80 P J SLATTERY

F/G 9/2

UNCLASSIFIED

NL

2 of 2

AD A
097 290



END
DATE
FILMED
5-81
DTIC

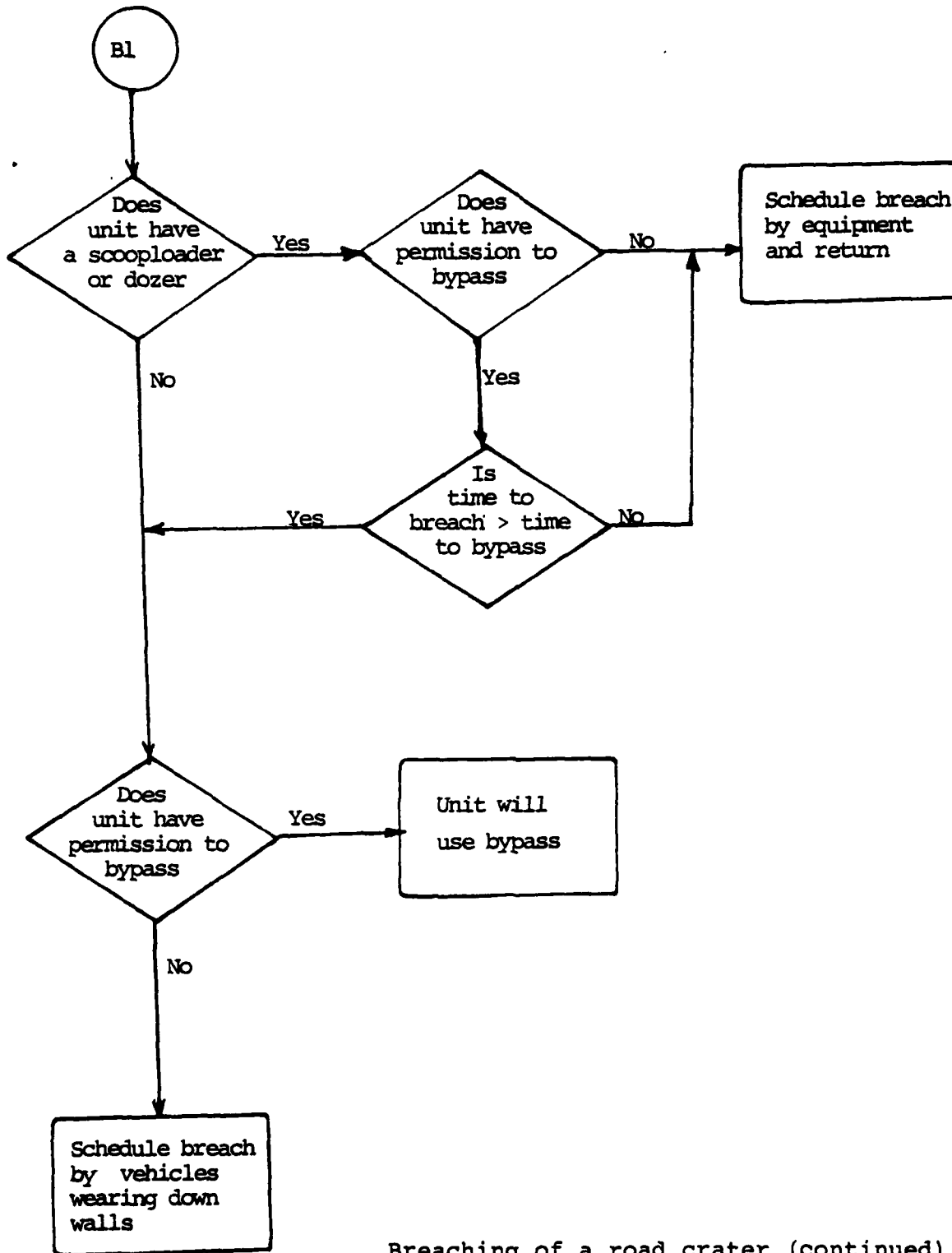

Breaching of a road crater (continued)

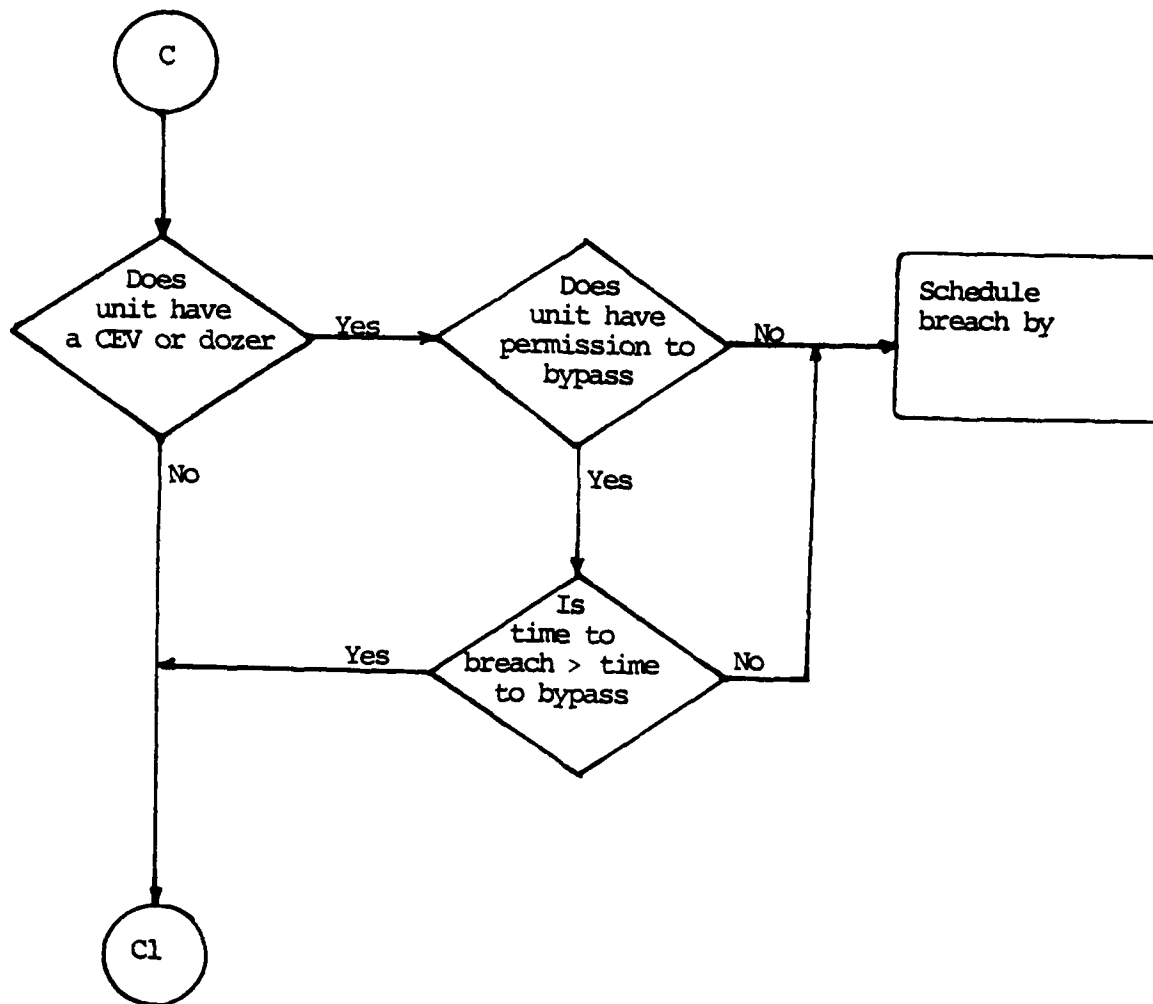

Breaching of an abatis.

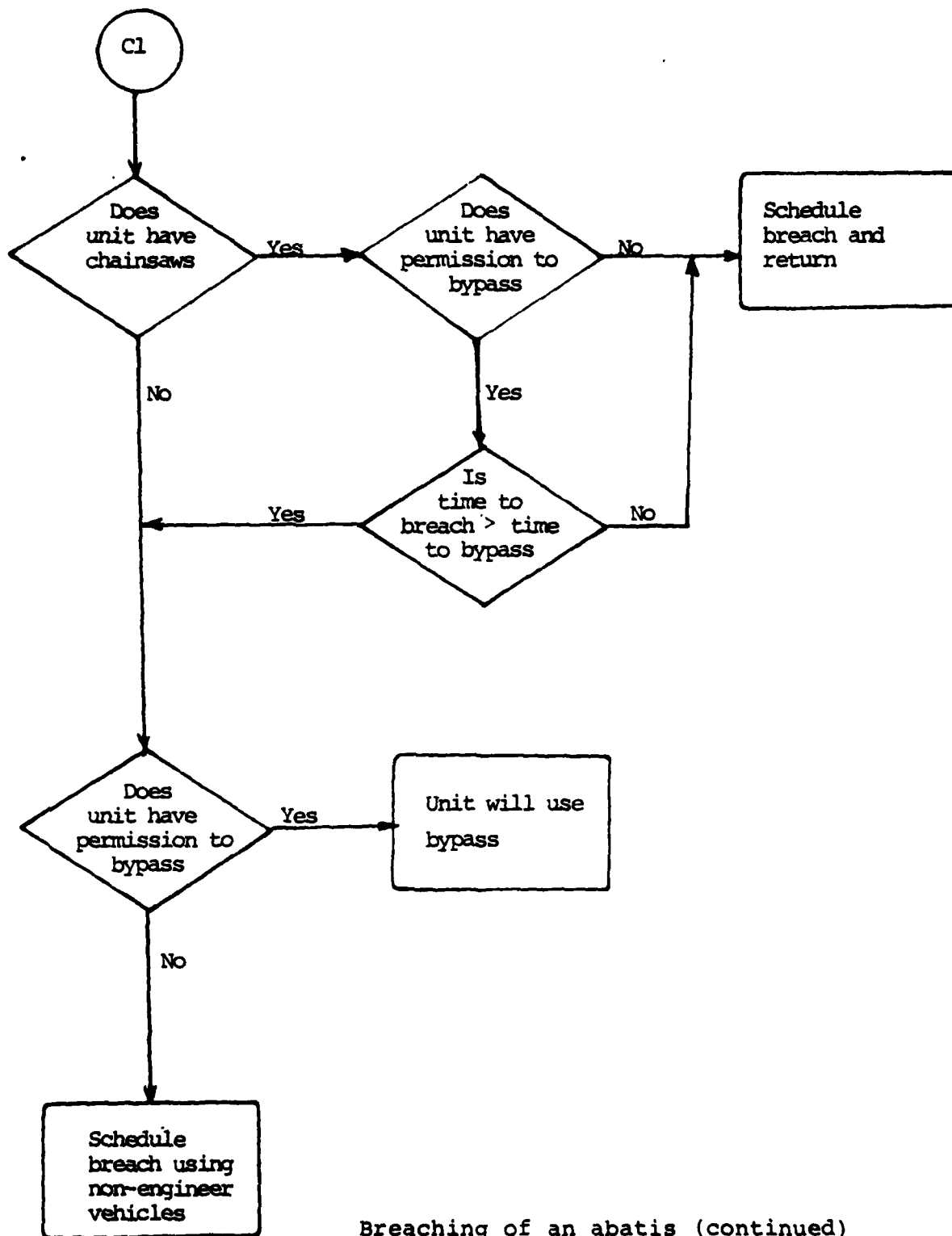

Breaching of an abatis (continued)

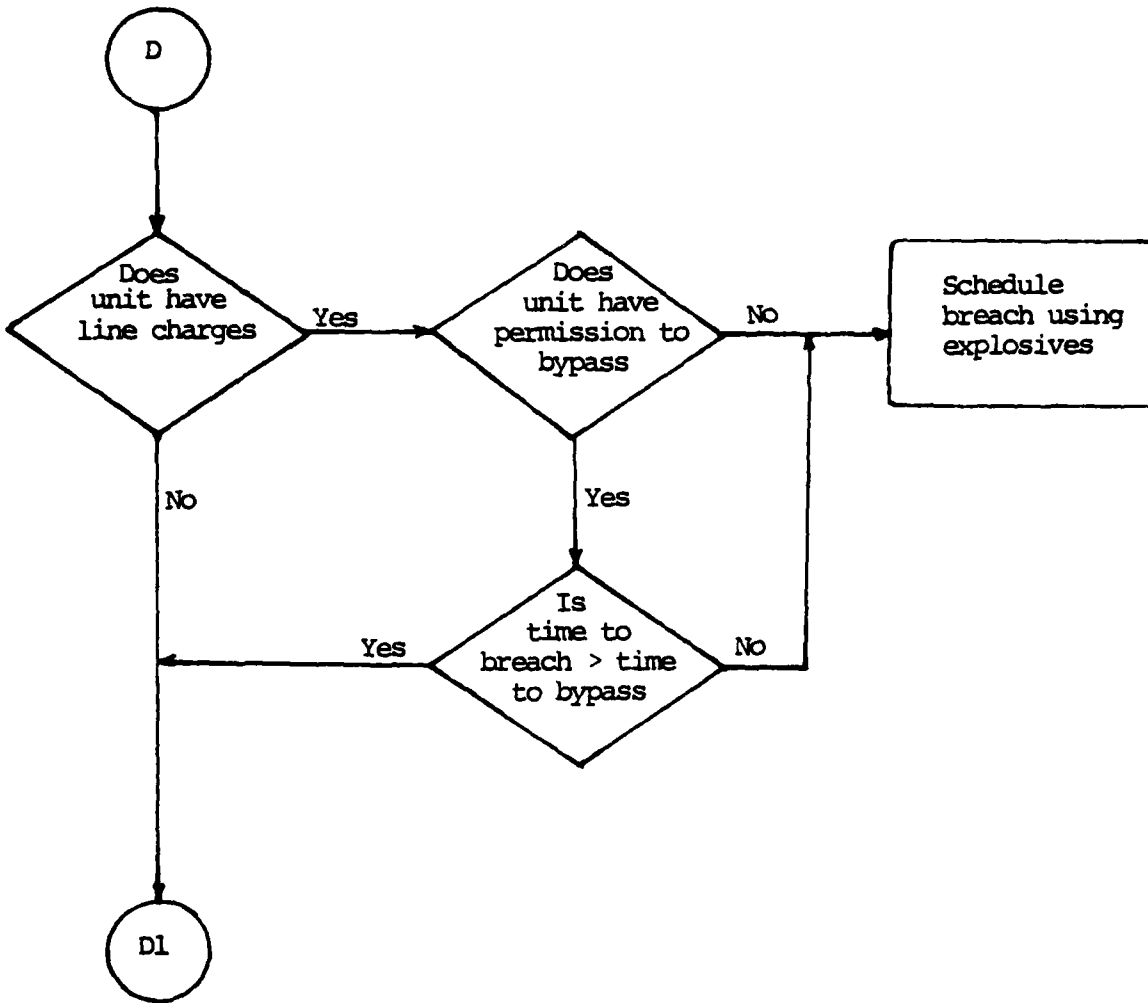

Breaching of wire obstacles

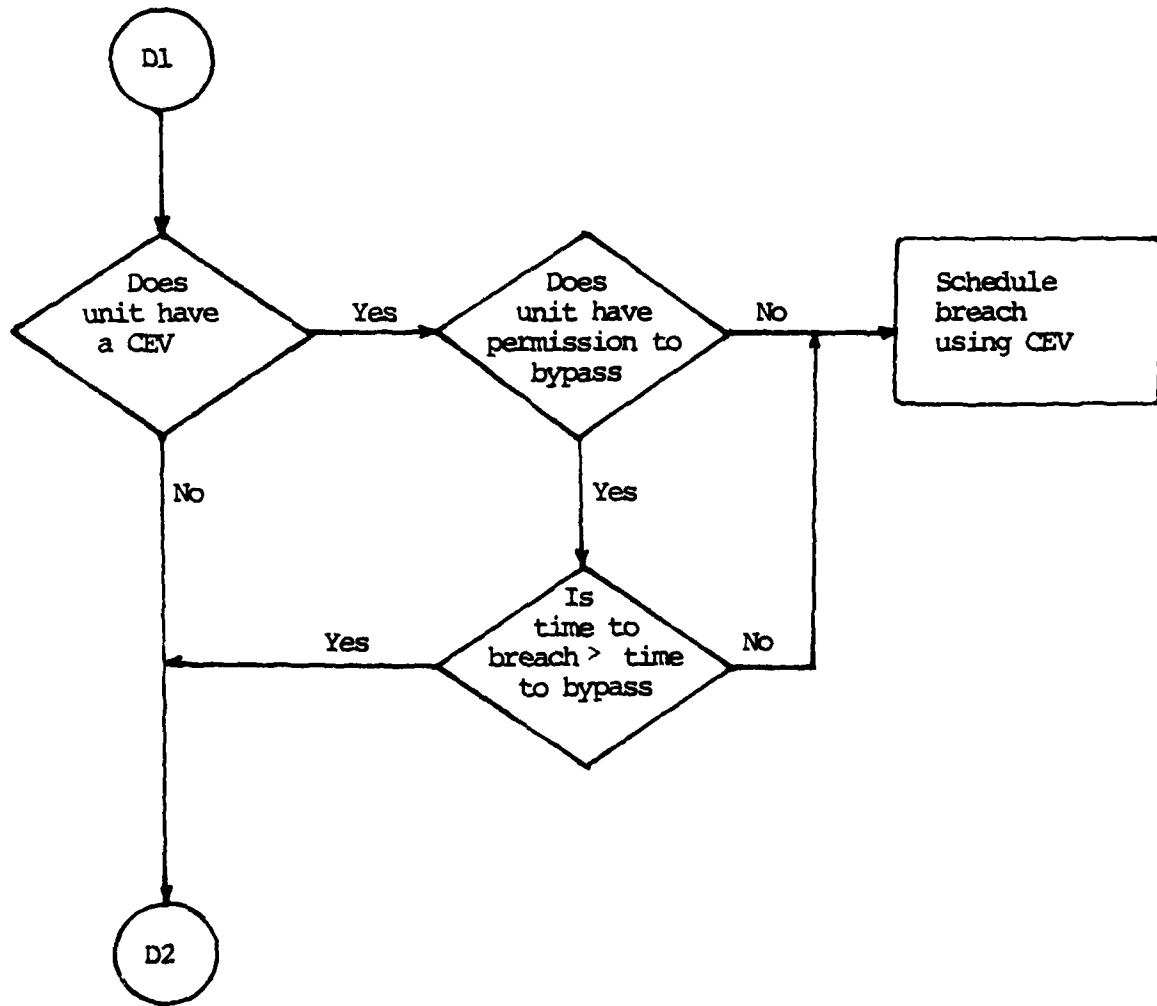

Breaching of wire obstacles (continued)

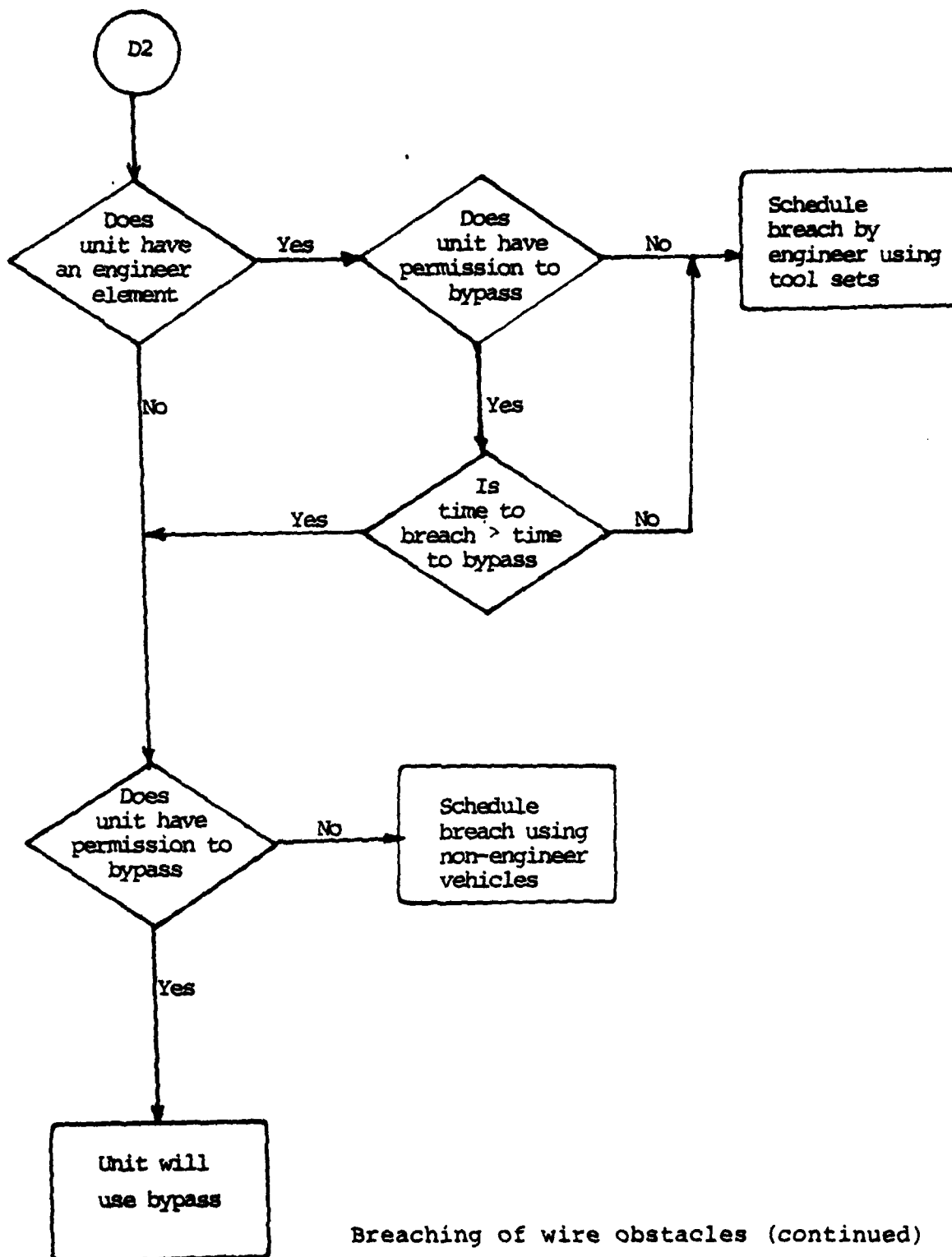

Breaching of wire obstacles (continued)

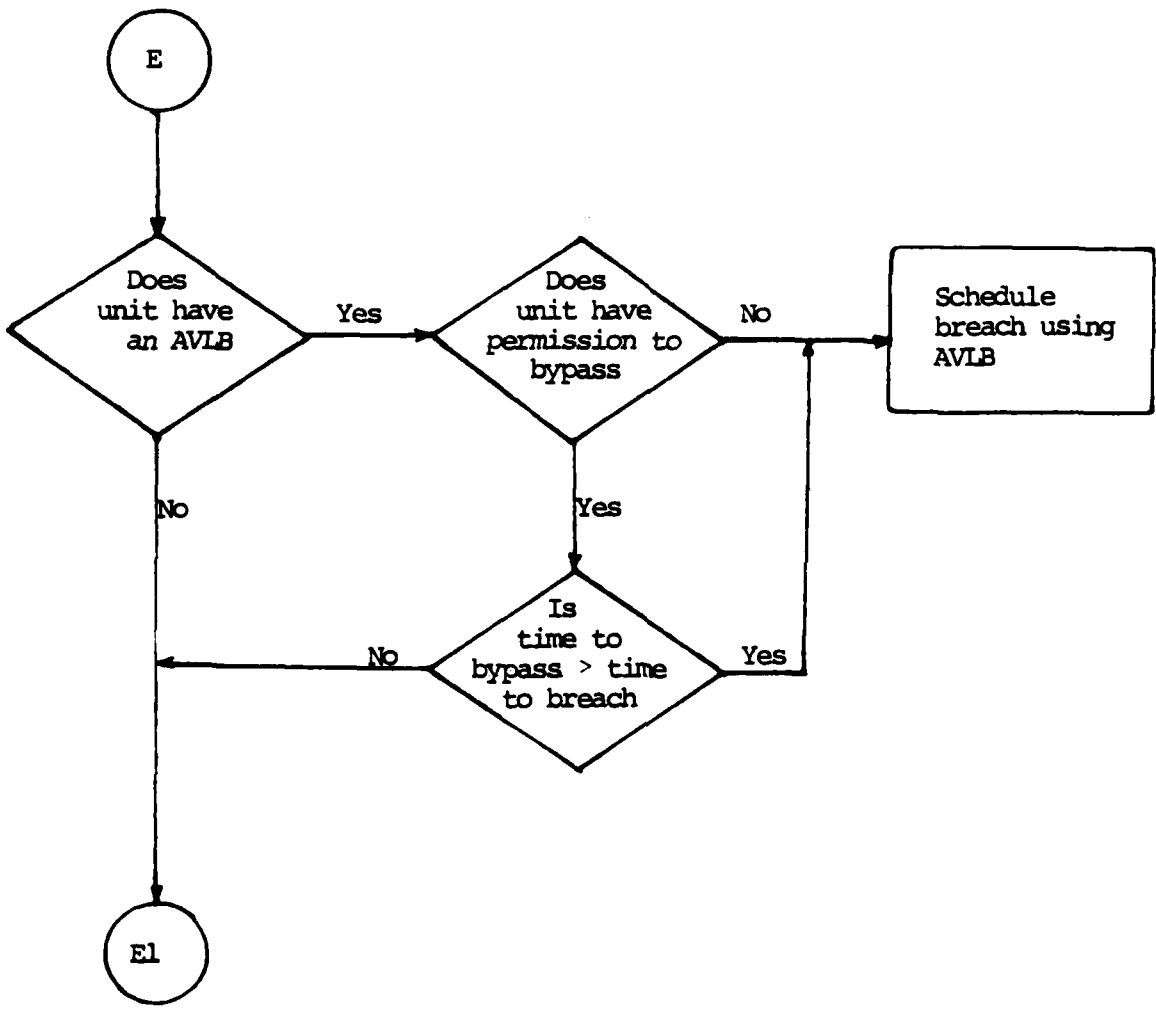

Breaching of anti-tank ditch.

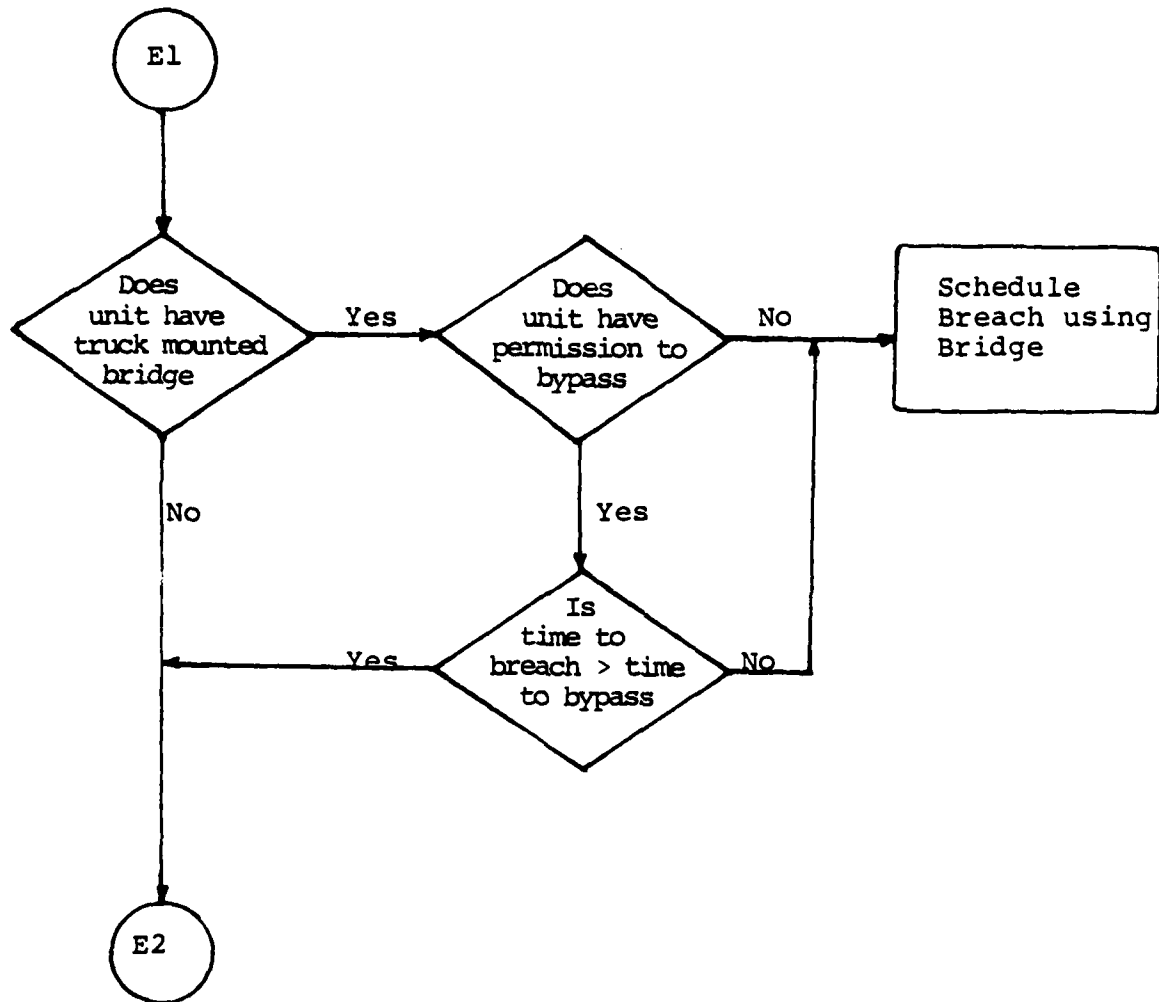

Breaching of anti-tank ditch (continued)

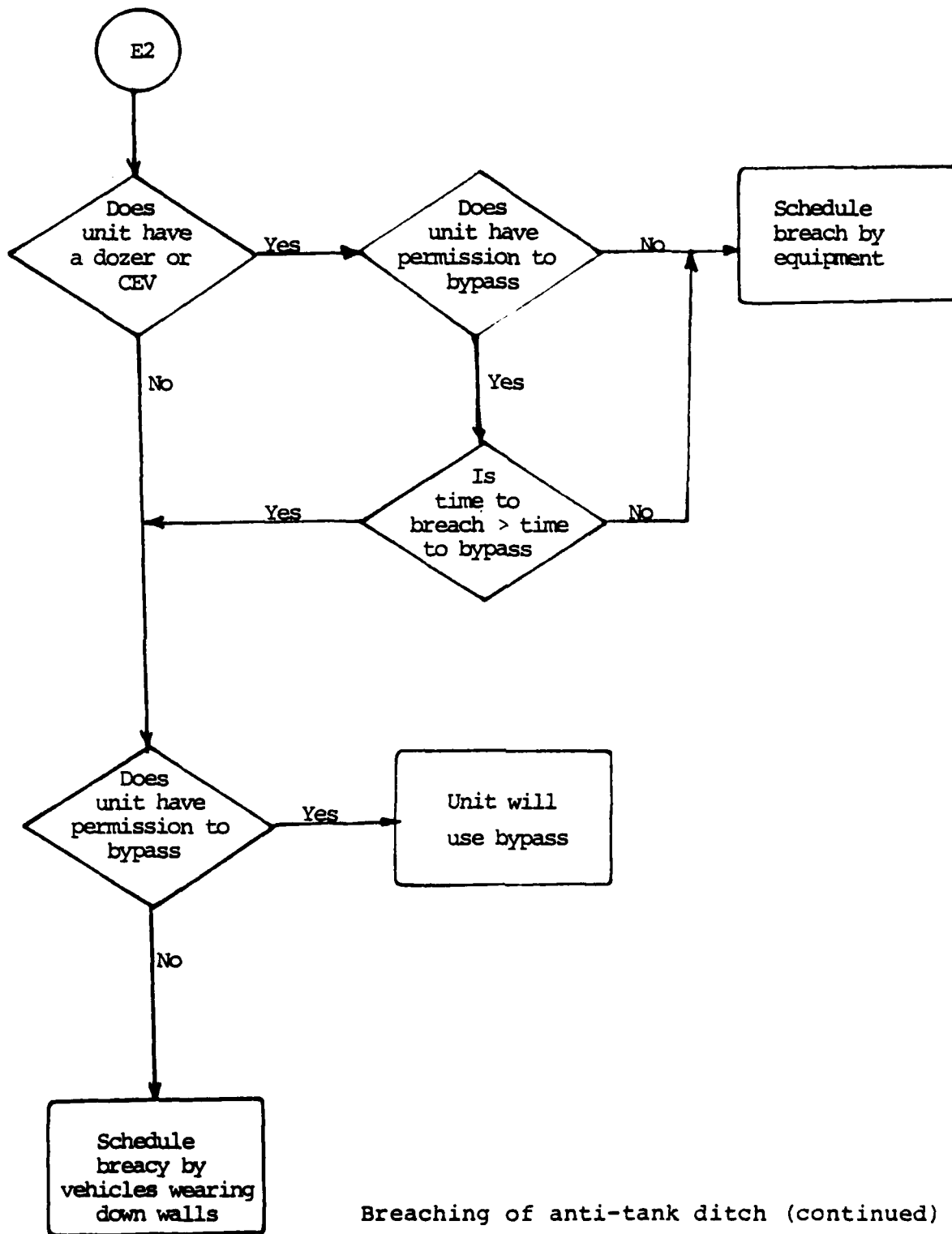

Breaching of anti-tank ditch (continued)

LIST OF REFERENCES

1. Hagewood, E.G. and Wallace, W.S., Simulation of Tactical Alternative Response (STAR), M.S. Thesis, Naval Postgraduate School, Monterey, California, June 1967.
2. Hartman, J.K., The STAR Field Module, Naval Postgraduate School, Technical Report NPS 55-80-021, May 1980.
3. Donnelly, C.N., "Combat Engineers of the Soviet Army," International Defense Review, Vol. II, No. 2, April 1978.
4. Department of the Army, FM 5-15, Field Fortifications.
5. Department of the Army, AR 310-10, Dictionary of Terms.
6. Department of the Army, FM 100-5, Operations, July 1976.
7. Department of the Army, FM 5-100, Engineer Combat Operations, August 1977.
8. Department of the Army, IAG-13-U-78, Soviet Army Operations, April 1978.

INITIAL DISTRIBUTION LIST

	No. Copies
1. Defense Technical Information Center Cameron Station Alexandria, Virginia 22314	2
2. Commandant U.S. Army Engineer School Combat Development Directorate Fort Belvoir, Virginia 22060 ATTN: CPT L.P. Gibson	1
3. Library, Code 0142 Naval Postgraduate School Monterey, California 93940	2
4. Professor James K. Hartman, Code 55Hh Department of Operations Research Naval Postgraduate School Monterey, California 93940	10
5. Professor James G. Taylor, Code 55Tw Department of Operations Research Naval Postgraduate School Monterey, California 93940	1
6. CPT Patrick J. Slattery 83-57 251 Street Bellerose, New York 11426	1
7. Professor K. T. Marshall, Code 55 Chairman, Department of Operations Research Naval Postgraduate School Monterey, California 93940	1

ATE
LMED
-8