



TR 80122

BR77355✓  
TR 80122

①



LEVEL II

ROYAL AIRCRAFT ESTABLISHMENT

9 \* 14  
Technical Report RAE-TR 80122

DTIC  
ELECTE  
APR 09 1981

11 October 1980

E

6  
CRACKS IN SHEETS HAVING  
STIFFENERS ATTACHED BY A  
SINGLE ROW OF RIVETS.

12 27

by

10 D.J./Cartwright  
D.P./Rooke

18 DTIC  
14 BR-77355

\*

Procurement Executive, Ministry of Defence  
Farnborough, Hants

DTIC FILE COPY

310450 81 3 12 069

UDC 539.219.2 : 539.4.014.11 : 624.078.8 : 621.884.2

ROYAL AIRCRAFT ESTABLISHMENT

Technical Report 80122

Received for printing 9 October 1980

CRACKS IN SHEETS HAVING STIFFENERS ATTACHED BY A SINGLE ROW OF RIVETS

by

D. J. Cartwright\*

D. P. Rooke

SUMMARY

The problem of a crack in a large stiffened sheet subjected to uniform stress remote from the crack has been analysed using complex variable techniques: the stiffeners are perpendicular to the crack and are each fixed to the sheet by a single row of rigid fasteners. Three quantities of engineering importance are derived, (i) the stress intensity factor of the crack, (ii) the forces at the points of attachment near the crack and (iii) the maximum load in each stiffener. The dependence of these quantities on the stiffness and spacing of the stiffeners and on the spacing of the fasteners is evaluated for a crack located in the sheet either symmetrically between two stiffeners or symmetrically under a stiffener. When the crack extends under the stiffener two cases are considered, the stiffener broken or unbroken.

Departmental Reference: Mat 407

Copyright

©  
Control Top BMCS London  
1980

Accession For	
NTIC GRAB	X
ERIC TM	
Univ. of	
...	

A

\* Department of Mechanical Engineering, The University, Southampton

LIST OF CONTENTS

	<u>Page</u>
1 INTRODUCTION	3
2 MODEL OF STIFFENED SHEET	4
3 METHOD OF ANALYSIS	4
4 THEORETICAL RESULTS	7
4.1 Bay centred crack	7
4.2 Stiffener centred crack: all stiffeners unbroken	9
4.3 Stiffener centred crack: central stiffener broken	9
5 CONCLUSIONS	10
List of symbols	11
References	12
Illustrations	Figures 1-20
Report documentation page	inside back cover

## 1 INTRODUCTION

A common form of wing and fuselage construction is stiffened sheets which are reinforced with stiffeners in order to provide adequate strength and stability, and to retard crack growth. The stiffeners may be integral with the sheet as when the component is machined from a thick plate, or they may be attached either continuously by welding or using an adhesive, or with discrete fasteners, by spot-welding or riveting. If such reinforced sheets are subjected to fluctuating stresses, fatigue cracks may occur.

Cracks may occur at any time during service life, and, in order to set inspection schedules and repair or replacement procedures for safe operation, it is necessary to be able to calculate both the growth of the crack and the critical crack-length beyond which failure occurs. These are both controlled by the stress intensity factor at the crack tip. The effects of structural parameters such as stiffener spacing, their relative stiffness and fastener spacing on the stress intensity factor are studied in this Report.

The retardation of crack-growth in the presence of stiffeners arises from the fact that, as the crack-tip grows near a stiffener, a greater proportion of the load is supported by that stiffener and this reduces the stress level in the sheet near the crack. Hence the stress intensity factor is reduced and so the growth-rate of the crack due to fatigue loads will also be reduced. The transfer of load from the sheet to the stiffener occurs at the points of attachment. There are thus equal and opposite forces from the sheet and stiffener acting on the fasteners (in an uncracked sheet these forces would be zero). It follows therefore, that near the crack the nominal stress in the stiffener increases and that local concentrations of stress occur at the points of attachment. These increased stresses may cause additional fatigue cracks to be initiated in the sheet or the stiffener at the points of attachment, and may even lead to the failure of a stiffener. A broken stiffener will not necessarily cause a complete structural failure, but it will significantly change the stress intensity factor; the effects of both broken and unbroken stiffeners are considered in this Report.

In order to optimise the design of a stiffened sheet structure it is therefore necessary to know not only the stress intensity factor in the presence of a crack, but also the maximum attachment loads and the maximum stiffener loads. These loads are evaluated in this Report and their dependence on structural parameters illustrated. A knowledge of these loads and of the stress intensity factor enables assessments to be made of the possible failure modes of a component. Failure may occur as a result of crack growth, or the failure of a fastener or the breaking of a stiffener.

Whilst many aspects of stiffened structures with cracks have been considered previously, most of the studies do not adequately cover the parameters of interest to the aerospace industry. In previous work stress intensity factors have been obtained for a crack near a continuously attached stiffener<sup>1-4</sup>, and for a crack near a stiffener with discrete points of attachment<sup>5-9</sup>. In these studies it was assumed that the stiffener would either fracture completely or remain intact as the crack passed under it. In practice partial cracking of the stiffener may occur and this has been considered<sup>10,11</sup>. The effects of both fastener deflection and in-plane bending stiffness on the stress

intensity factor has been analysed for stiffeners with both continuous<sup>12</sup> and discrete<sup>13,14</sup> methods of attachment. Debonding of continuously attached stiffeners and its effect on the stress intensity factor has been studied<sup>15,16</sup>. The effect of yielding at the crack tip on the stress in the stiffener has been examined<sup>17</sup> and the effects of attaching the stiffener by a double row of rivets has been analysed<sup>18</sup>.

Except for Poe's work<sup>7</sup>, these investigations have not included parametric studies. The results presented in this Report supplement those given by Poe<sup>7</sup> and in particular cover the range of parameters important in the design and construction of aircraft structures. Results of similar parametric studies for cracks near stiffeners attached by a double rather than a single row of rivets will be reported later.

## 2 MODEL OF STIFFENED SHEET

The model configurations studied in this Report are shown in Figs 1 and 2. Both configurations consist of an infinite flat sheet containing a crack of length  $2a$ ; the sheet is reinforced by a periodic set of stiffeners attached at discrete intervals along lines perpendicular to the crackline. The sheet of thickness  $t$  has a Young's modulus  $E$  and a Poisson's ratio  $\nu$ , and the stiffeners of cross-sectional area  $A_s$  have a Young's modulus  $E_s$ . In one configuration the crack is located midway between two stiffeners (see Fig 1) and in the other the crack is centred on one of the stiffeners (see Fig 2). For the stiffener-centred crack, the stiffener which crosses the crack may be either intact or broken at the crackline.

For the purpose of these fracture mechanics calculations, it is assumed that the stiffeners are concentrated at the sheet surface and that they have zero in-plane bending stiffness. They are fixed to the sheet a distance  $b$  apart with rigid fasteners of diameter  $d$  a distance  $p$  apart. The sheet is in a state of plane stress and is subjected to a uniform tensile stress  $\sigma$  remote from and perpendicular to the crack. In order to maintain strain compatibility between the sheet and the stiffener, the stiffeners are subjected to a stress  $\sigma_s (= \sigma E_s / E)$  remote from the crack.

For the configurations in Figs 1 and 2 the number of stiffeners was taken to be six and seven respectively. This was found sufficient, for all crack lengths, to represent an infinite number of stiffeners; increasing the number had negligible effects on the numerical results. The number of points of attachment per stiffener was increased until the stress intensity factor changed by less than 0.01%; the attachment forces are less accurate with errors up to 4%. For the range of parameters studied Poe<sup>7</sup> has shown that the results are insensitive to values of  $d/p \leq 0.25$ ; the value 0.25, which is typical of aerospace structures, was used in this work.

## 3 METHOD OF ANALYSIS

In the analysis each stiffener is represented as a distribution of point forces. This distribution is determined so as to satisfy compatibility of displacements and equilibrium of forces between the sheet and the stiffener where they are attached. The forces which occur at the points of attachment (eg rivet locations) are obtained by solving a set of simultaneous equations which arises from the compatibility conditions.

The load concentration in each stiffener is obtained by summing the point forces and the uniform end load on the stiffener. The stress intensity factor is determined by summing the effects due to the forces using a known Green's function for a single force, and adding the result to that for a crack in a uniformly stressed sheet.

The compatibility condition, which requires that the displacement of the sheet between any two points of attachment must equal the displacement of the stiffener between the same two attachment points, can be written<sup>17</sup> as follows

$$\Delta v_{m,n}^a + \Delta v_{m,n}^b = \Delta v_{m,n}^d \quad (1)$$

The relative displacement,  $\Delta v_{m,n}^a$  represents the elongation of the sheet between the  $n$ th and  $(n+1)$ th fastener along the  $m$ th stiffener due to the remote stress  $\sigma$ . The attachment points are numbered consecutively from the crackline,  $n = 1$  being the one nearest the crack. The relative displacement  $\Delta v_{m,n}^b$  is the elongation in the sheet, between the  $n$ th and the  $(n+1)$ th fastener, due to the point forces and  $\Delta v_{m,n}^d$  is the corresponding elongation of the stiffener due to both the uniform stress  $\sigma E_s/E$  and the attachment forces. The relative displacements can be written in terms of the complex function defined by Erdogan<sup>19</sup>: this has been done by Cartwright and Rich<sup>17</sup> for a crack of length  $2a$  lying along the real ( $x$ ) axis with the centre at  $z = 0$  ( $z = x + iy$ ,  $i = \sqrt{-1}$ ). The relative displacement is defined as

$$\Delta v_{m,n}^a = \frac{\sigma a(1+\nu)}{2E} \left[ \bar{v}^a(z_{m,n+1}) - \bar{v}^a(z_{m,n}) \right]; \quad (2)$$

where  $z_{m,n+1}$  and  $z_{m,n}$  are the coordinates of the  $(n+1)$ th and the  $n$ th fastener in the  $m$ th stiffener, and the functions  $\bar{v}^a(z_{m,n+1})$  and  $\bar{v}^a(z_{m,n})$  are dimensionless displacements in the  $y$  direction at each of these points respectively. For the special case of the displacement between the  $x$ -axis and the first point of attachment, this becomes

$$\Delta v_{m,0}^a = \frac{\sigma a(1+\nu)}{2E} \bar{v}^a(z_{m,1}) \quad (2a)$$

The elongation  $\Delta v_{m,n}^b$  is given by

$$\Delta v_{m,n}^b = \frac{(1+\nu)}{Et} \sum_{k=1}^M \sum_{r=1}^N P_{k,r} \left[ \bar{v}^b(z_{k,r}; z_{m,n+1}) - \bar{v}^b(z_{k,r}; z_{m,n}) \right] \quad (3)$$

and

$$\Delta v_{m,0}^b = \frac{(1+\nu)}{Et} \sum_{k=1}^M \sum_{r=1}^N P_{k,r} \bar{v}^b(z_{k,r}; z_{m,1}) \quad (3a)$$

where  $\bar{v}^b(z_{k,r}; z_{m,n+1})$  and  $\bar{v}^b(z_{k,r}; z_{m,n})$  are respectively the dimensionless displacements at  $z_{m,n+1}$  and  $z_{m,n}$  resulting from a pair of collinear opposing forces  $P_{k,r}$  acting perpendicular to and away from the crackline at  $z_{k,r}$  and  $\bar{z}_{k,r}$ . The summation limit  $N$  is the number of fasteners each side of the crackline and  $M$  is the number of

stiffeners. The elongation  $\Delta v_{m,n}^d$  in the stiffener between the  $n$ th and the  $(n+1)$ th fasteners is given by

$$\Delta v_{m,n}^d = \frac{p_0^c}{E} + \frac{p}{A_s E_s} \sum_{j=n+1}^N p_{m,j}^s \quad (4a)$$

and between the first fastener and the  $x$  axis by

$$v_{m,0}^d = \frac{p_0^c}{E} + \frac{p_0}{A_s E_s} \sum_{j=1}^N p_{m,j}^s \quad (4b)$$

where  $p_{m,j}^s$  is the force at the  $j$ th fastener in the  $m$ th stiffener,  $z_{m,j}$  at  $z_{m,j}$  and  $p_0$  is the distance from the crackline to the first fastener in each stiffener. The first term on the right hand side of equations (4a) and (4b) is the uniform extension of the interval due to the remote stress  $\sigma E_s/E$  applied to the stiffener. The second term is the uniform extension of the interval between the  $n$ th and the  $(n+1)$ th fastener in the  $m$ th stiffener, resulting from the attachment forces at and beyond the  $(n+1)$ th fastener. Details of the functions  $\bar{v}_{m,n}^a$ ,  $\bar{v}_{m,n}^b$  and  $\bar{v}_{m,n}^d$  are given in the Appendix of Ref 17.

Equilibrium at each point of attachment is given by

$$P_{k,i} + P_{k,i}^s = 0 \quad (k = 1, M; i = 1, N) \quad (5)$$

The substitution of equations (2) to (5) into equation (1) gives the following series of simultaneous equations, which can be solved for the unknown attachment forces  $P_{k,i}$ :

$$\begin{aligned} (1 + \nu) \sum_{k=1}^M \sum_{i=1}^N \bar{P}_{k,i} \left[ \bar{v}^b(z_{k,i}; z_{m,n+1}) - \bar{v}^b(z_{k,i}; z_{m,n}) \right] + \frac{\lambda \gamma_n}{2^n} \sum_{j=n+1}^N \bar{P}_{m,j} \\ = \frac{\lambda \gamma_n}{2^n} - \frac{(1 + \nu) \lambda}{4} \left[ \bar{v}^a(z_{m,n+1}) - \bar{v}^a(z_{m,n}) \right] \end{aligned} \quad (6)$$

where  $\lambda = \frac{2aEt}{A_s E_s}$ ,  $\gamma_n = \frac{a}{p}$ ,  $\bar{P}_{k,i} = \frac{P_{k,i}}{A_s \sigma_s}$

and  $\gamma_0 = \frac{p_0}{p}$  and  $\gamma_n = 1$  for  $n \geq 1$ .

The stress intensity factor  $K_I$  is given by

$$\frac{K_I}{\sigma \sqrt{a}} = 1 + \frac{1}{\pi \sigma a t} \sum_{k=1}^M \sum_{i=1}^N P_{k,i} G(z_{i,j}) \quad (7)$$

where  $G(z_{k,j})$  is the Green's function for the stress intensity factor resulting from a pair of collinear opposing unit forces located at  $z_{k,j}$  and  $\bar{z}_{k,j}$  and acting in the sheet in a direction away from and perpendicular to the crackline.

When the  $m$ th stiffener is broken at the crackline the compatibility condition for the interval across the crackline in that stiffener is replaced by

$$\sigma_s A_s + \sum_{j=1}^N F_{m,j} = 0 \quad (8)$$

which expresses the condition that the force in the first interval of the broken  $m$ th stiffener is zero. Details of the functions  $v_{m,i}^{(c)}$   $i = a, b, d$  are given in the Appendix of Ref 17.

The above formulation is applicable to a configuration in which the stiffeners can be spaced an arbitrary distance apart; each is located across and perpendicular to the crackline and has an equal number of fasteners either side of the crackline. However in order to limit the number of variables, solutions have been obtained for equally spaced stiffeners located symmetrically about the position of the crack. Some solutions are available elsewhere<sup>18,20</sup> for a crack located asymmetrically with respect to the stiffeners.

#### 4 THEORETICAL RESULTS

##### 4.1 Bay centred crack

The normalised stress intensity factors  $K_I / (\sigma \sqrt{\pi a})$  for the bay centred crack shown in Fig 1 are plotted in Figs 3, 4 and 5 as a function of  $(a/b)$  the ratio of the semi-crack length  $a$  to the stiffener spacing  $b$ . Results are given for the ratios of the attachment pitch  $p$  to the stiffener spacing equal to  $1/3$ ,  $1/6$  and  $1/12$  in Figs 3, 4 and 5 respectively. Each figure shows results for four values of  $\mu$ , the ratio of the stiffness of the stiffeners to that of sheet and stiffeners combined. The values chosen, 0.1, 0.2, 0.3 and 0.5 cover the range used in typical aircraft structures;  $\mu$  is given, in terms of the sheet and stiffener properties, by

$$\mu = \frac{A_s E_s}{btE + A_s E_s} \quad (9)$$

For small values of  $a/b$ , all stress intensity factors approach  $\sigma \sqrt{\pi a}$  the stress intensity factor for an isolated crack of length  $2a$  in an unreinforced sheet subjected to a uniform stress normal to the direction of the crackline. As the crack tips approach the stiffener the stress intensity factor decreases. For fixed values of  $p/b$  and  $a/b$ , the stress intensity factor decreases as the relative stiffness  $\mu$  is increased. Decreasing the attachment pitch at constant  $a/b$  causes the stress intensity factor to be reduced for all values of  $\mu$ .

The load concentration at the crackline in the  $m$ th stiffener is given by the ratio  $L_m / (\sigma bt)$  where  $L_m$  is the load in the stiffener when the sheet is cracked and  $\sigma bt$  is

the load carried by one bay (width  $b$ ) when the sheet is uncracked. The ratio depends on the point forces in the following way:

$$\frac{L_m}{bt} = \frac{p}{1-\alpha} + \frac{1}{bt} \sum_{j=1}^N P_{m,j} \quad (10)$$

or

$$\frac{L_m}{s A_s} = 1 + \frac{1}{s A_s} \sum_{j=1}^N P_{m,j} \quad (11)$$

since

$$(1-\alpha) s A_s = 2b t \quad (12)$$

The maximum concentration of load at the crackline occurs in the two stiffeners adjacent to the crack; values of  $L_m/(b t)$  are shown (full lines) as a function of  $a/b$  in Figs 6, 7 and 8 for values of  $p/b$  equal to  $1/3$ ,  $1/6$  and  $1/12$  respectively. The normalised attachment force  $P_{1,1}/(b t)$  at the first fastener on each side of the crackline in the two stiffeners are also shown (dashed lines) in Figs 6, 7 and 8 as a function of  $a/b$  for the same values of  $p/b$ . Attachment forces at other locations are, in general, less than these. Results are given for both the load concentration factor and the attachment force at values of the relative stiffness  $\alpha$  equal to 0.1, 0.2, 0.3 and 0.5.

For small values of  $a/b$ , the first attachment forces  $P_{1,1}$  are negligible and the load concentration approaches  $1/(1-\alpha)$  the value for an uncracked sheet. This is in accord with the behaviour of the stress intensity factor which approaches that for the unstiffened sheet for small  $a/b$  (see Figs 3 to 5). As the relative crack length  $a/b$  increases the load concentration in the stiffeners also increases. For fixed values of the relative attachment pitch  $p/b$  and relative crack length  $a/b$ , the load concentration increases as the relative stiffness  $\alpha$  is increased. Decreasing the attachment pitch causes the load concentration in the stiffener to be further increased. Thus the reductions in the stress intensity factors shown in Figs 3 to 5 are a direct result of the increase in loads carried by the stiffeners.

For  $a/b < 0.4$  at values of  $p/b = 1/12$  (see for example Fig 8) the force  $P_{1,1}$  at the first attachment point is negative. This indicates that the force is acting away from the line of the crack and hence would tend to increase the stress intensity factor. However positive forces at the other attachment points will be sufficient to ensure that the stress intensity factor does not increase. For these ratios of relative crack length and attachment pitch (i.e.  $a/b < 0.4$ ,  $p/b = 1/12$ ) the attachment force  $P_{1,1}$  is not necessarily the largest one in the stiffener, as it is for  $a/b > 0.4$  or larger values of  $p/b$ . However for  $a/b < 0.4$ ,  $p/b = 1/12$  all the attachment forces are small, of the order of  $P_{1,1}$  shown in Fig 8. Thus for practical purposes  $P_{1,1}$  may be treated as the maximum attachment force in the stiffener for all values of the parameters given.

#### 4.2 Stiffener centred crack: all stiffeners unbroken

Normalised stress intensity factors  $K_I/(C\sqrt{a})$  have been calculated for the stiffener centred crack (see Fig 2) with all the stiffeners unbroken. They are plotted as a function of the relative crack length  $a/b$  in Figs 9, 10 and 11 for three values of the relative attachment pitch  $p/b$ ,  $1/3$ ,  $1/6$  and  $1/12$  respectively. Each figure shows results for values of the relative stiffness  $\nu$  equal to 0.1, 0.2, 0.3 and 0.5. Again for small values of  $a/b$  all stress intensity factors approach the value for an isolated crack in an unreinforced sheet. As the crack lengthens the increased load supported by the central stiffener causes the stress intensity factor to be reduced to less than that for the isolated crack; and for still longer cracks there is a pronounced reduction in the stress intensity factor as the crack tips pass the two stiffeners on each side of the central stiffener ( $a/b > 1.0$ ). The dependence of the stress intensity factor on the relative pitch  $p/b$  and the relative stiffness  $\nu$  are similar to that for the bay centred crack: reducing  $p/b$  and increasing  $\nu$  causes a reduction in the stress intensity factor for all values of  $a/b$ .

The load concentration  $L_0/(Cbt)$  at the crackline in the central, most highly loaded, stiffener is shown in Figs 12, 13 and 14 (full lines) as a function of  $a/b$  for values of  $p/b$  equal to  $1/3$ ,  $1/6$  and  $1/12$  respectively. The normalised attachment force  $P_{0,1}/(Cbt)$  at the first, most highly loaded, attachment point either side of the crackline in the central stiffener is also shown in Figs 12 to 14 (dashed lines) as a function of  $a/b$  for the same values of  $p/b$ . Results are given for both the load concentration and the attachment force for  $\nu$  equal to 0.1, 0.2, 0.3 and 0.5. For small values of  $a/b$  the maximum attachment force  $P_{0,1}$  is negligible and the load  $L_0$  at the crackline in the central stiffener approaches  $Cbt/(1-\nu)$  the value if the sheet were uncracked. This is in agreement with the behaviour of the stress intensity factor which also approaches that for the unstiffened sheet at small values of  $a/b$  (see Figs 9, 10 and 11). The dependency of the load concentration on the relative attachment pitch  $p/b$  and the relative stiffness  $\nu$  are similar to that for the bay centred crack: reducing  $p/b$  and increasing  $\nu$  both have the effect of causing an increase in the load concentration at the crackline in the central stiffener. Again there is a reduction in the stress intensity factor resulting from the increase in load supported by the stiffeners.

#### 4.3 Stiffener centred crack: central stiffener broken

The normalised stress intensity factors  $K_I/(C\sqrt{a})$  are plotted in Figs 15, 16 and 17 for the stiffener centred crack (see Fig 2) in which the central stiffener is broken at the crack line. They are plotted as a function of the relative crack length  $a/b$  in Figs 15, 16 and 17. Results are given for values of  $p/b$  equal to  $1/3$ ,  $1/6$  and  $1/12$  respectively. Each figure shows results for values of the relative stiffness  $\nu$  equal to 0.1, 0.2, 0.3 and 0.5. The effect of the broken stiffener is to increase the stress intensity factor to greater than that for a similar crack in an unstiffened sheet. This increase is greater at small values of  $a/b$  where the crack is entirely in the region of high stress near the end of the broken stiffener. For a given value of  $a/b$  ( $< 0.8$ ), both increasing the relative stiffness  $\nu$  and decreasing the relative attachment pitch  $p/b$

have the effect of increasing the stress intensity factor. This dependence is reversed for longer cracks ( $a/b > 1.0$ ) and becomes similar to that for the case where the central stiffener is unbroken, see section 4.2.

The load concentration  $\sigma_1/(c\delta t)$  at the crackline in the two most highly loaded stiffeners immediately on each side of the broken central stiffener are shown, as a function of  $a/b$ , in Figs 18, 19 and 20 for  $p/b$  equal to 1/3, 1/6 and 1/12 respectively. Results are given at values of the relative stiffness  $\mu$  equal to 0.1, 0.2, 0.3 and 0.5. For small values of  $a/b$  the load concentration approaches  $\mu/(1-\mu)$ , the value if the sheet were uncracked. The dependence of the load concentration on  $\mu$  and  $p/b$  is similar to that for the bay centred crack and the stiffener centred crack with all stiffeners intact. For all values of  $a/b$  the load concentration increases as  $p/b$  is reduced and  $\mu$  is increased.

Two attachment forces are important in this case  $P_{0,1}$  and  $P_{1,1}$ , the forces at the first fastener on each side of the crackline, of both the central and the adjacent stiffener respectively. Values of  $P_{0,1}/(c\delta t)$  and  $P_{1,1}/(c\delta t)$  are also shown in Figs 18, 19 and 20 as a function of  $a/b$  for  $p/b$  equal to 1/3, 1/6 and 1/12 respectively. The results were obtained for values of  $\mu$  equal to 0.1, 0.2, 0.3 and 0.5. The force  $P_{1,1}$  approaches zero at small values of  $a/b$  and increases abruptly as the crack tip approaches the stiffeners ( $a/b \geq 0.8$ ). The force  $P_{0,1}$  acts in a direction away from the crackline; it therefore opens the crack and increases the stress intensity factor, and it is largest at small values of  $a/b$ . This is in agreement with the results shown in Figs 15, 16 and 17 where for small  $a/b$ , the stress intensity factor is greater than that for a similar crack in an unstiffened sheet.

The force  $P_{0,1}$  at the first fastener of the broken stiffener decreases as the value of  $p/b$  decreases and increases as  $\mu$  increases. With increasing values of  $a/b$  the force  $P_{0,1}$  approaches a constant value and for  $a/b > 1.0$  (crack tips at or beyond the first unbroken stiffeners) the magnitude is sufficiently small relative to  $P_{1,1}$  for it to have a negligible effect on the stress intensity factor.

## 5 CONCLUSIONS

- (1) Stress intensity factors have been obtained for a crack in a stiffened sheet for a wide range of typical structural configurations. These results are useful for parametric design studies of cracked structures subjected to both static and fatigue loads.
- (2) The stress intensity factors, stiffener load concentrations and maximum attachment forces are all required in order to assess the various failure modes of stiffened structures.
- (3) The formulation and the methods of solution are applicable to configurations with unequally spaced stiffeners and can be used to obtain results for cracks near stiffeners which are attached by a double row of rivets. Results for such configurations will be reported later.

## LIST OF SYMBOLS

$a$	semi-crack length
$A_s$	cross-sectional area of stiffeners
$b$	stiffener spacing
$d$	diameter of attachment (rivet)
$E$	Young's modulus of elasticity of sheet
$E_s$	Young's modulus of elasticity of stiffener
$G(z_{i,j})$	Green's function for a point force in the positive $y$ direction at $z_{i,j}$
$i,j,k$	summation suffices
$K_I$	opening mode stress intensity factor
$L_m$	load in the $m$ th stiffener at the crackline ( $y = 0$ )
$m,n$	summation suffices
$M$	number of stiffeners
$N$	number of attachments points in each stiffener on each side of the crackline
$p$	distance between attachments
$p_0$	distance from crackline to nearest attachment
$P_{i,j}$	attachment force at $z_{i,j}$ in the sheet
$P_{i,j}^s$	attachment force at $z_{i,j}$ in the stiffener
$\bar{P}_{i,j}$	$= P_{i,j} / (t_s A_s)$
$t$	thickness of sheet
$\bar{v}^a(z_{m,n})$	dimensionless displacement in sheet due to uniform stress
$\bar{v}^b(z_{i,j}, z_{m,n})$	dimensionless displacement in sheet due to attachment force
$\Delta v_{m,n}^a$	relative displacement in sheet due to uniform stress
$\Delta v_{m,n}^b$	relative displacement in sheet due to attachment forces
$\Delta v_{m,n}^d$	relative displacement in stiffener due to uniform stress and attachment forces
$(x,y)$	rectangular cartesian coordinates
$z$	$= x + iy$
$z_{i,j}$	coordinate of $i$ th attachment in $j$ th stiffener
$\gamma_0$	$= p_0/p$
$\gamma_n$	$= 1, n \geq 1$
$r$	$= a/p$
$\lambda$	$= 2aEt / (A_s E_s)$
$\mu$	stiffness ratio $= A_s E_s / (btE + A_s E_s)$
$\nu$	Poisson's ratio
$\tau$	uniform stress on sheet
$\tau_s$	uniform stress on stiffeners

## REFERENCES

- | <u>No.</u> | <u>Author</u>                                | <u>Title, etc</u>  |
|------------|--|--|
| 1          | M. Isida<br>Y. Itagaki                       | Stress concentration at the tip of a central transverse crack in a stiffened plate subject to tension.<br>Proc. 4th US Nat. Cong. Appl. Mechanics, pp 955-969 (1962)                                 |
| 2          | R. Greif<br>J.L. Sanders                     | The effect of a stringer on the stress in a cracked sheet.<br><i>J. Appl. Mech.</i> , <u>32</u> , pp 59-66 (1965)  |
| 3          | J.L. Sanders                                 | Effect of a stringer on the stress concentration due to a crack in a thin sheet.<br>NASA Tech. Report R-13 (1959)  |
| 4          | T. Kanazawa<br>S. Machida<br>M. Ohyagi       | Some basic considerations on crack arresters - Part IV.<br><i>J. Soc. Naval Arch. Japan</i> , <u>121</u> , pp 225-234 (1967)<br>RAE Library Translation 1648 (1972)                                  |
| 5          | J.P. Romoualdi<br>J.T. Frasier<br>G.R. Irwin | Crack extension force near a riveted stringer.<br>NRL Report 4956, Washington, DC (1957)   |
| 6          | J.M. Bloom<br>J.L. Sanders                   | The effect of a riveted stringer on the stress in a cracked sheet.<br><i>J. Appl. Mech.</i> , <u>33</u> , pp 561-570 (1966)  |
| 7          | C.C. Poe                                     | Stress intensity factors for a cracked sheet with riveted and uniformly spaced stringers.<br>NASA Tech. Report R-358 (1971)  |
| 8          | T. Kanazawa<br>S. Machida<br>M. Ohyagi       | Some basic considerations on crack arresters - Part V.<br><i>J. Soc. Naval Arch. Japan</i> , <u>122</u> , pp 200-214 (1967)<br>RAE Library Translation 1648 (1972)                                   |
| 9          | C.C. Poe                                     | The effect of broken stringers on the stress intensity factor for a uniformly stiffened sheet containing a crack.<br>NASA TM X-71947 (1973)  |
| 10         | R.B. Madison                                 | Application of fracture mechanics to bridges.<br>Ph.D. Thesis, Lehigh University (1969)  |
| 11         | M. Miller<br>D.J. Cartwright                 | Stress intensity factors for a crack in two intersecting uniformly stressed sheets.<br><i>Int. J. Engng. Sci.</i> , <u>12</u> , pp 353-359 (1974)  |
| 12         | K. Arin                                      | A note on the effect of lateral bending stiffness of stringers attached to a plate with a crack.<br><i>Engng. Fracture Mechanics</i> , <u>7</u> , 173-179 (1975)                                     |
| 13         | T. Swift                                     | The effects of fastener flexibility and stiffener geometry on the stress intensity in stiffened cracked sheet.<br>Proceedings of Conference on <i>Prospects of Fracture Mechanics</i> , Delft (1974) |

## REFERENCES (continued)

- | <u>No.</u> | <u>Author</u>                             | <u>Title, etc.</u>  |
|------------|---|---|
| 14         | D.J. Cartwright<br>G. Dowrick             | Effects of attachment deflection on fatigue crack growth rate of a crack in a stiffened sheet.<br>In <i>Fracture Mechanics in Engineering Materials</i> ,<br>Edited by P. Stanley, pp 361-377, Applied Science Publishers,<br>London (1977)       |
| 15         | K. Arin                                   | A plate with a crack, stiffened by a partially debonded stringer.<br><i>Engng. Fract. Mech.</i> , <u>9</u> , pp 133-140 (1977)  |
| 16         | D.J. Cartwright<br>M. Miller              | Stress intensity factors for a crack in a sheet with a partially<br>debonded stiffener.<br><i>Int. J. Fracture</i> , <u>11</u> , 925-932 (1977)   |
| 17         | D.J. Cartwright<br>T.P. Rich              | Plastic strip yielding for a crack in a stiffened sheet.<br>Proc. 1st International Conference on <i>Advanced Mechanics of<br/>Fracture Mechanics</i> , edited by A.R. Luxmore and D.R.J. Owen,<br>pp 550-568, University College, Swansea (1978) |
| 18         | K. Wang<br>D.J. Cartwright                | A crack near doubly riveted stiffeners.<br>Proc. 4th International Conference on Fracture, pp 647-656,<br>Volume 3, Waterloo, Canada (1977)   |
| 19         | F. Erdogan                                | On the stress distribution in plates with collinear cuts under<br>arbitrary loads.<br>Proc. 4th US Nat. Appl. Mechanics, pp 547-553 (1962)  |
| 20         | W.G. Heath<br>L.F. Nichols<br>W.T. Kirkby | Practical applications of fracture mechanics techniques to<br>aircraft structural problems.<br>In <i>Fracture Mechanics in Engineering Materials</i> , pp 1-1 to 1-17,<br>Agardograph 221 (1976)  |

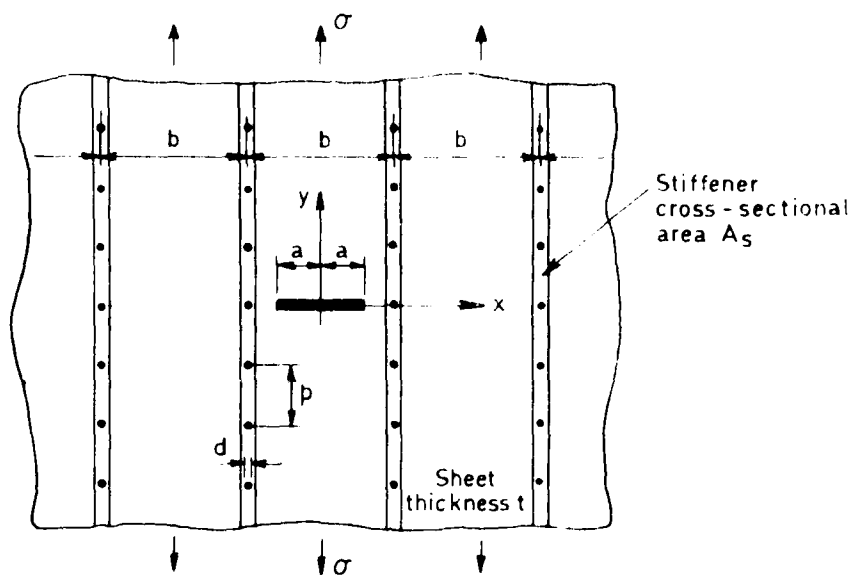

Fig 1 Stiffened sheet with bay-centred crack

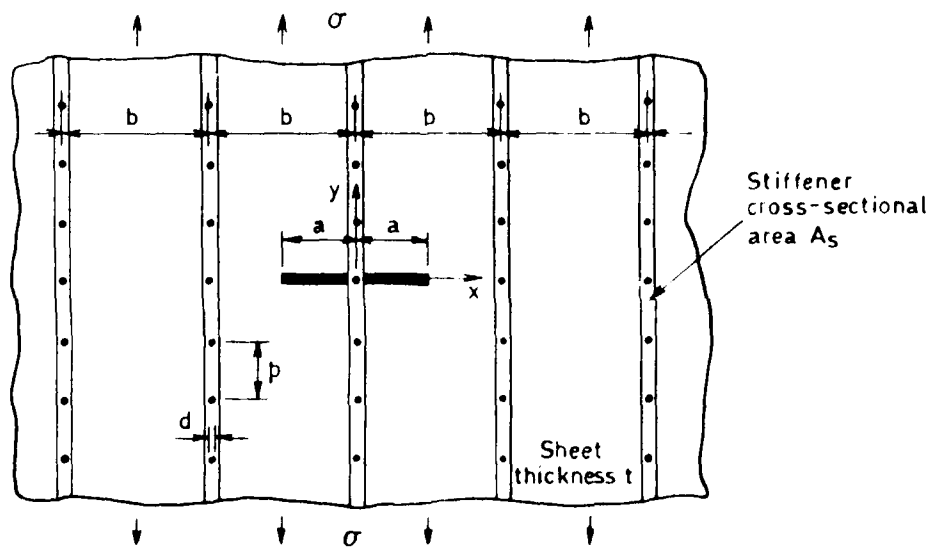

Fig 2 Stiffened sheet with stiffener-centred crack: central stiffener unbroken or broken at crackline

Fig 3

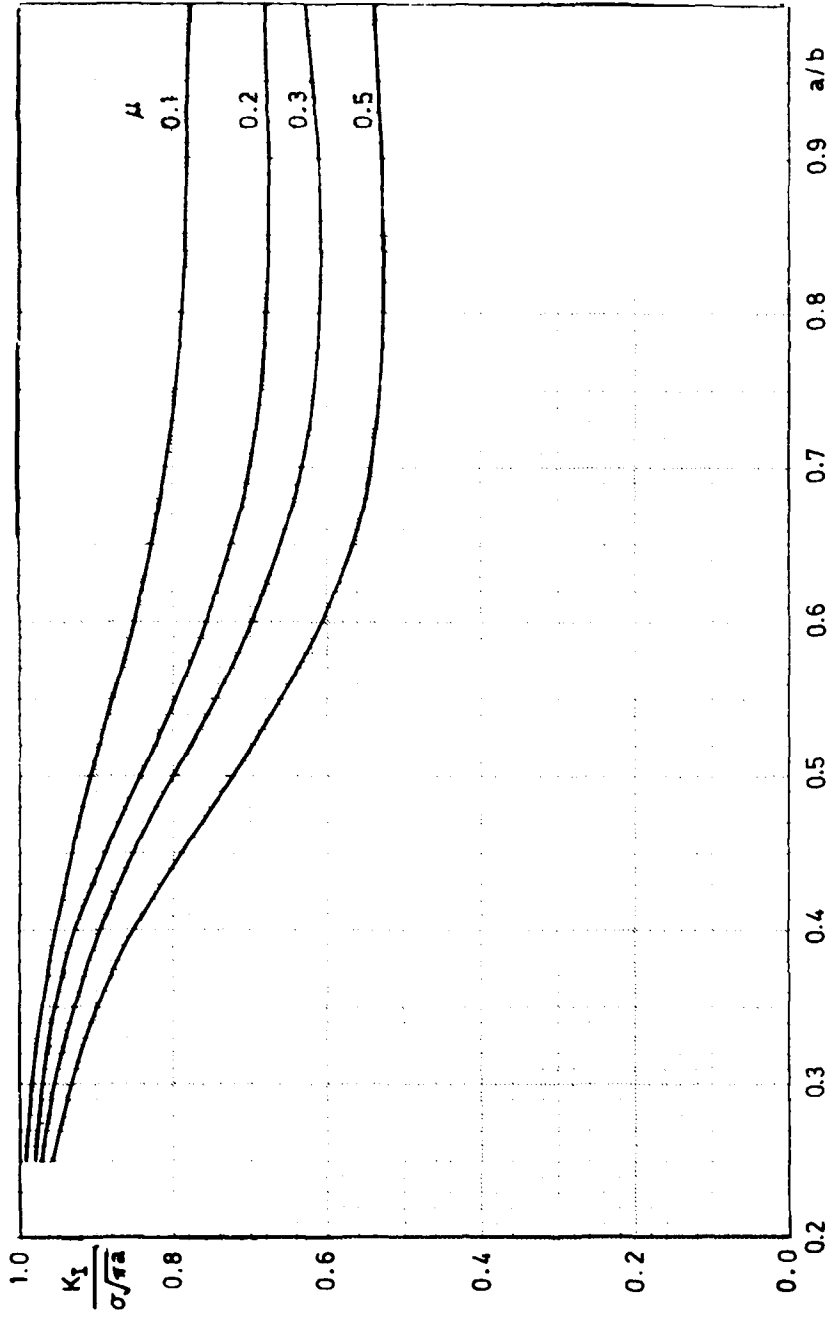

Fig 3 Stress intensity factors for a bay-centred crack:  $p/b = 1/3$

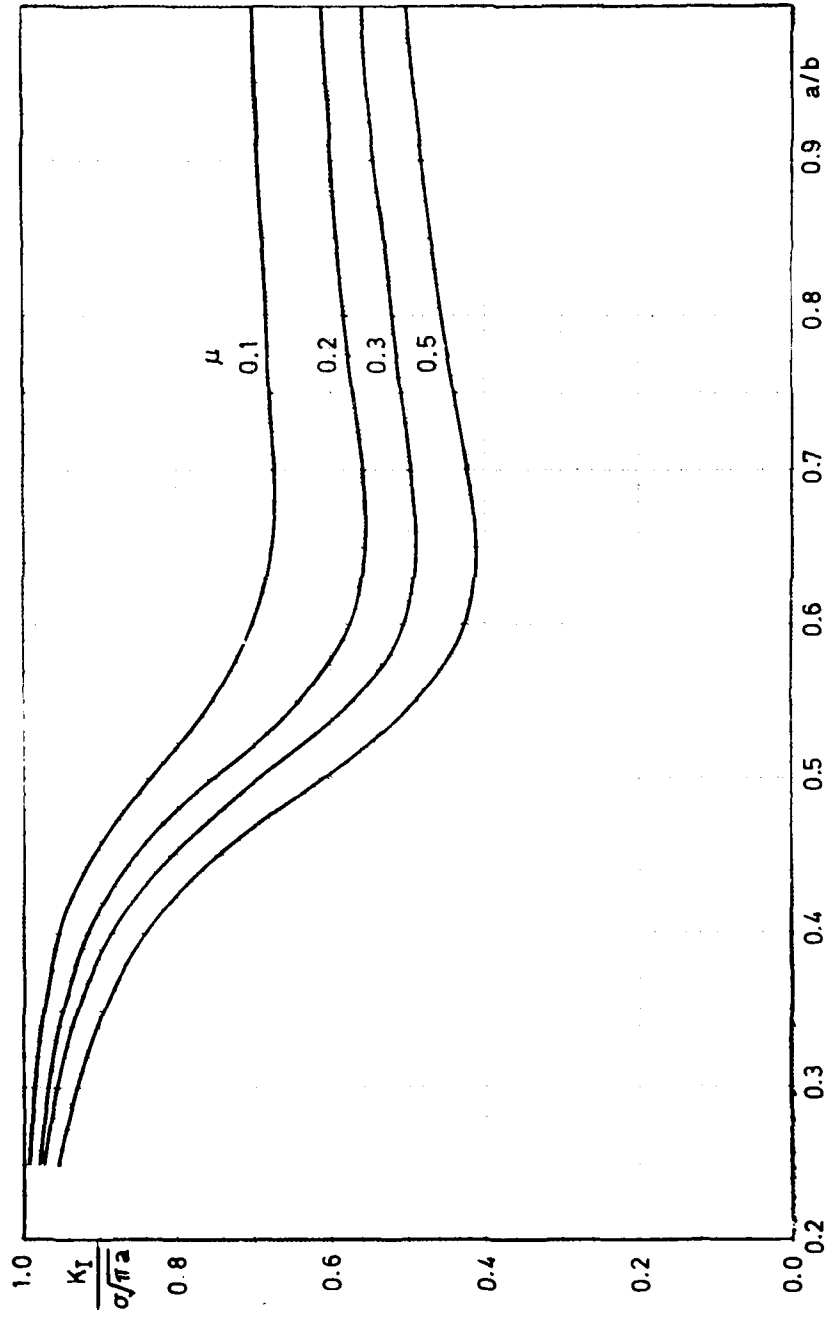

Fig 4 Stress intensity factors for a bay-centred crack:  $p/b = 1/6$

Fig 5

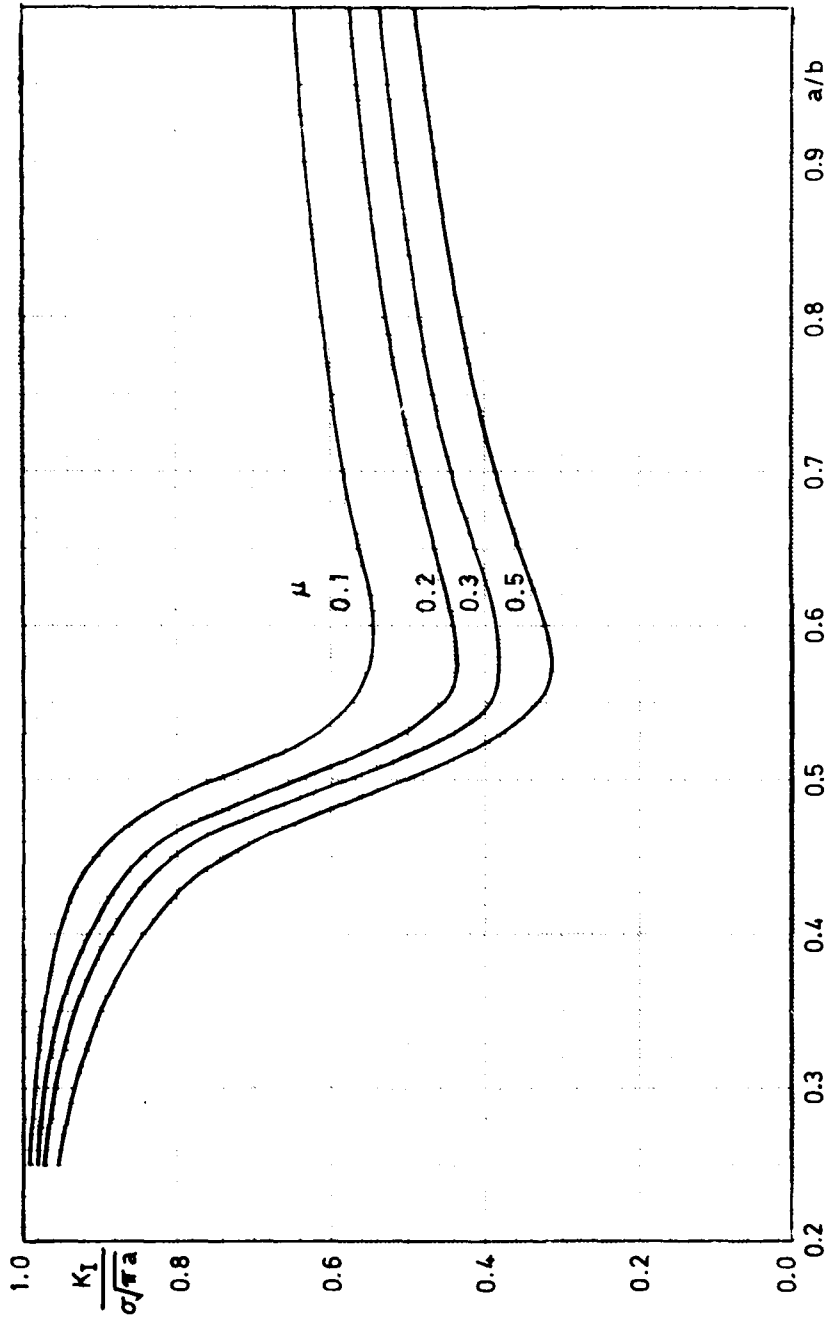

Fig 5 Stress intensity factors for a bay-centred crack:  $p/b = 1/12$

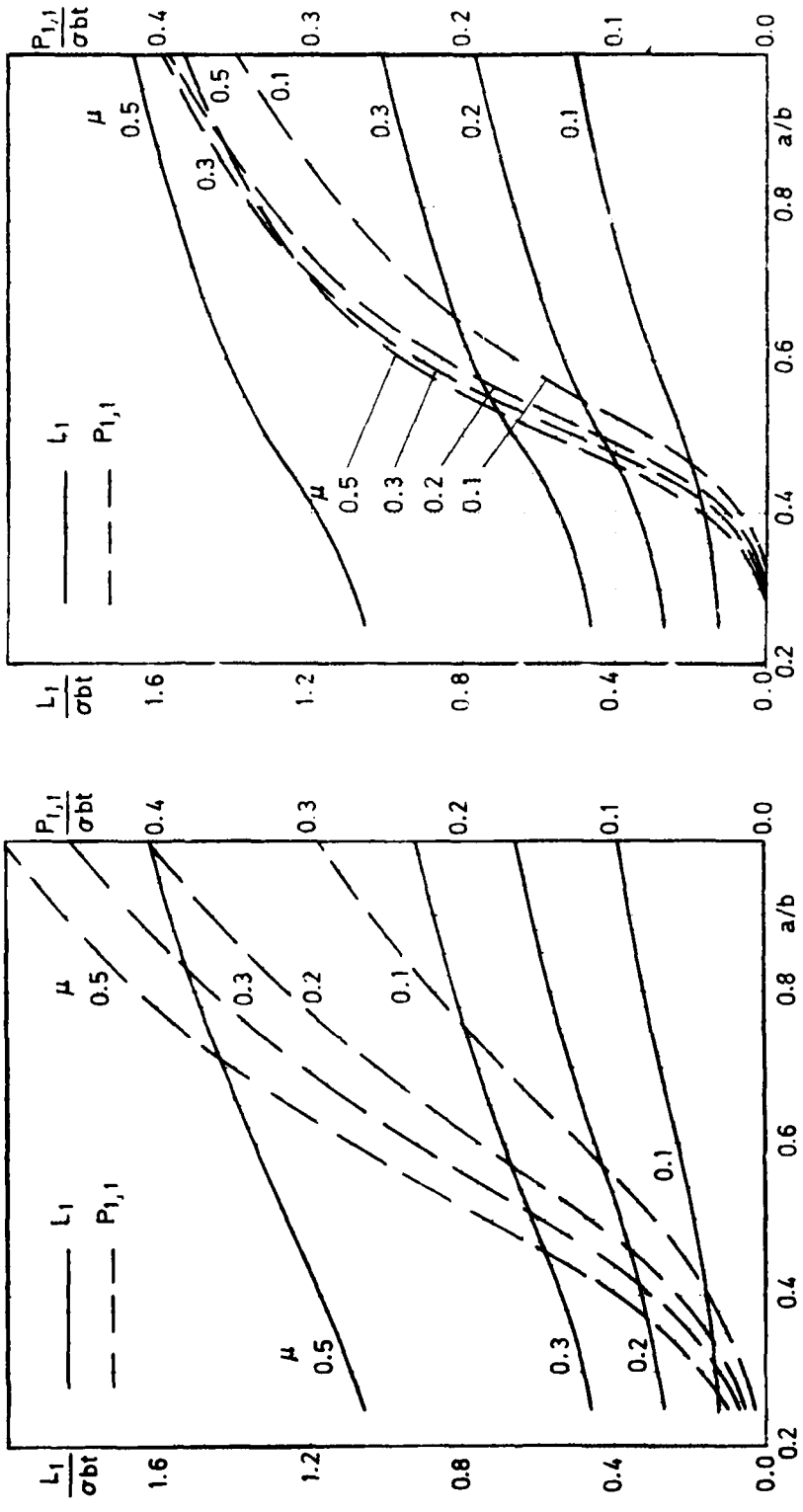

Fig 6  $p/b = 1/3$

Fig 7  $p/b = 1/6$

Figs 6&7 Load concentration and first attachment force for the pair of stiffeners nearest to a bay-centred crack:  $p/b = 1/3$  and  $1/6$

Fig 8

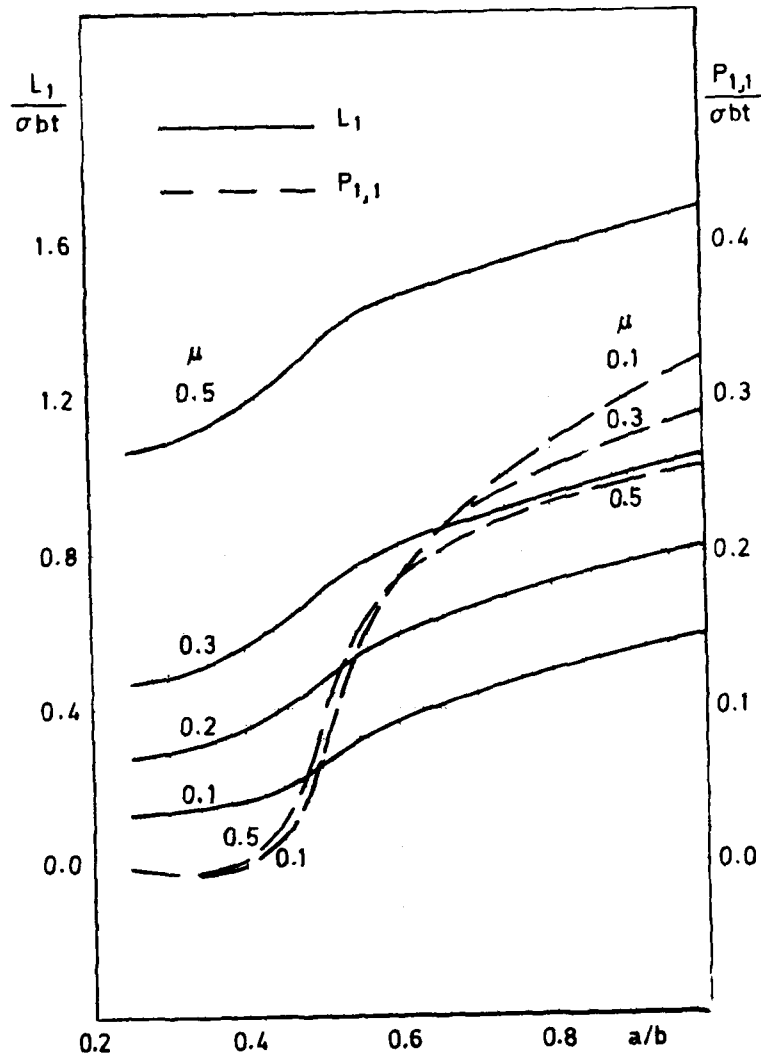

Fig 8 Load concentration and first attachment force for the pair of stiffeners nearest to a bay centred crack.  $p/b = 1/12$

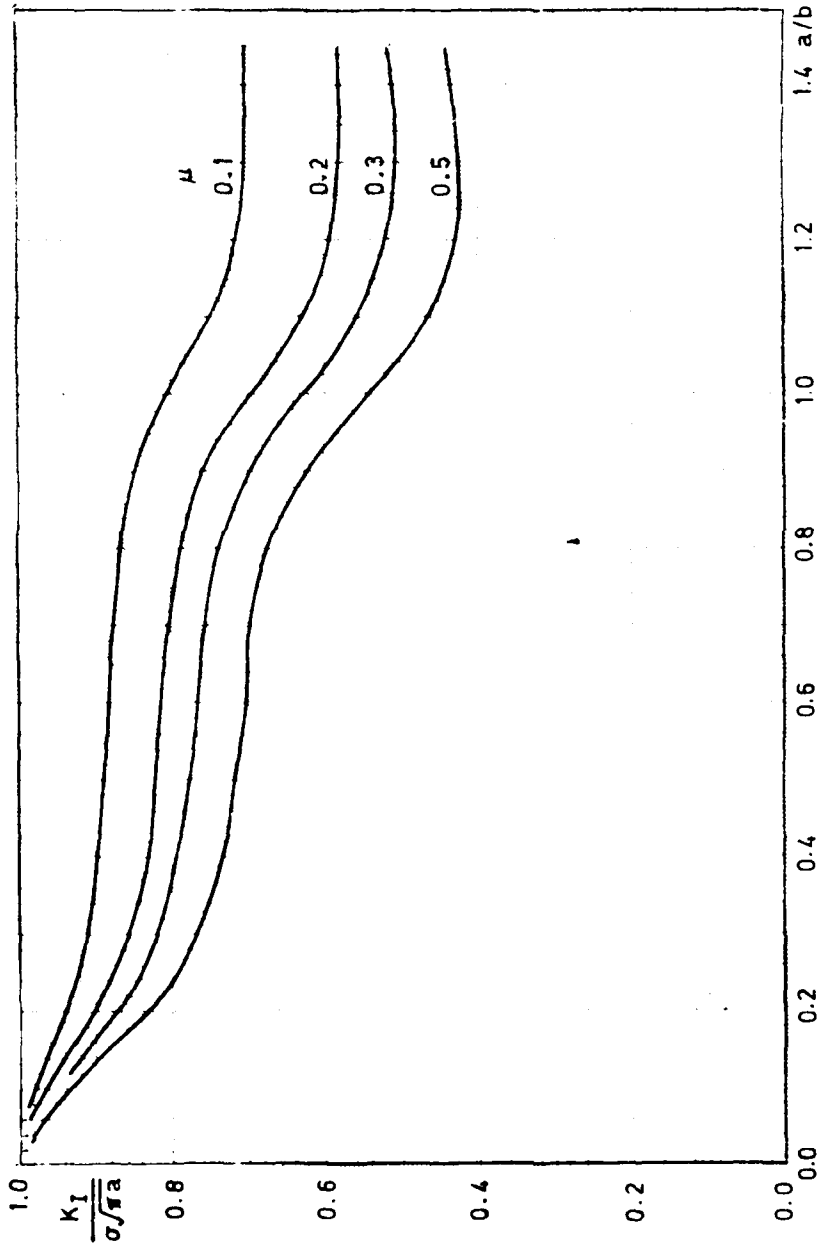

Fig 9 Stress intensity factors for a crack centred on an unbroken stiffener:  $p/h = 1/3$

Fig 10

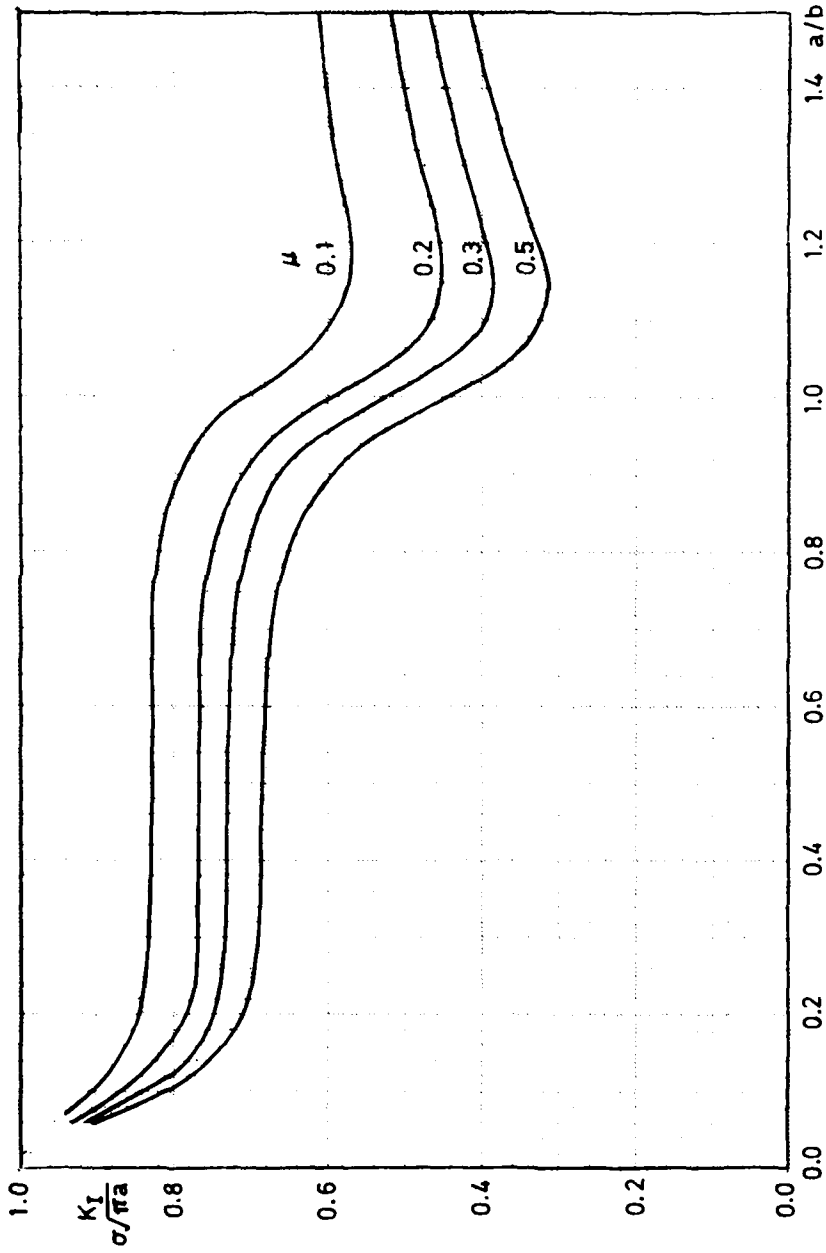

Fig 10 Stress intensity factors for a crack centred on an unbroken stiffener:  $p/b = 1/6$

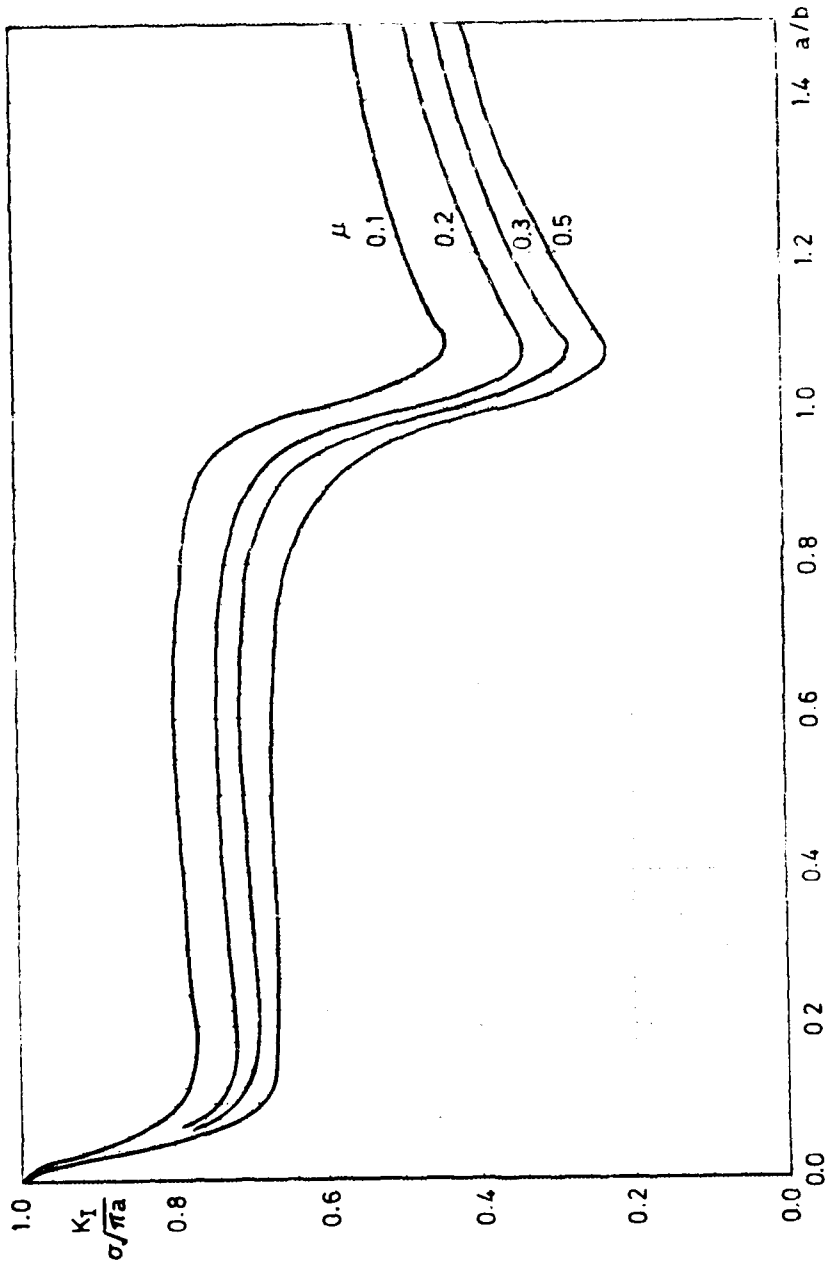

Fig 11 Stress intensity factors for a crack centred on an unbroken stiffener:  $\nu/b = 1/12$

Fig 12

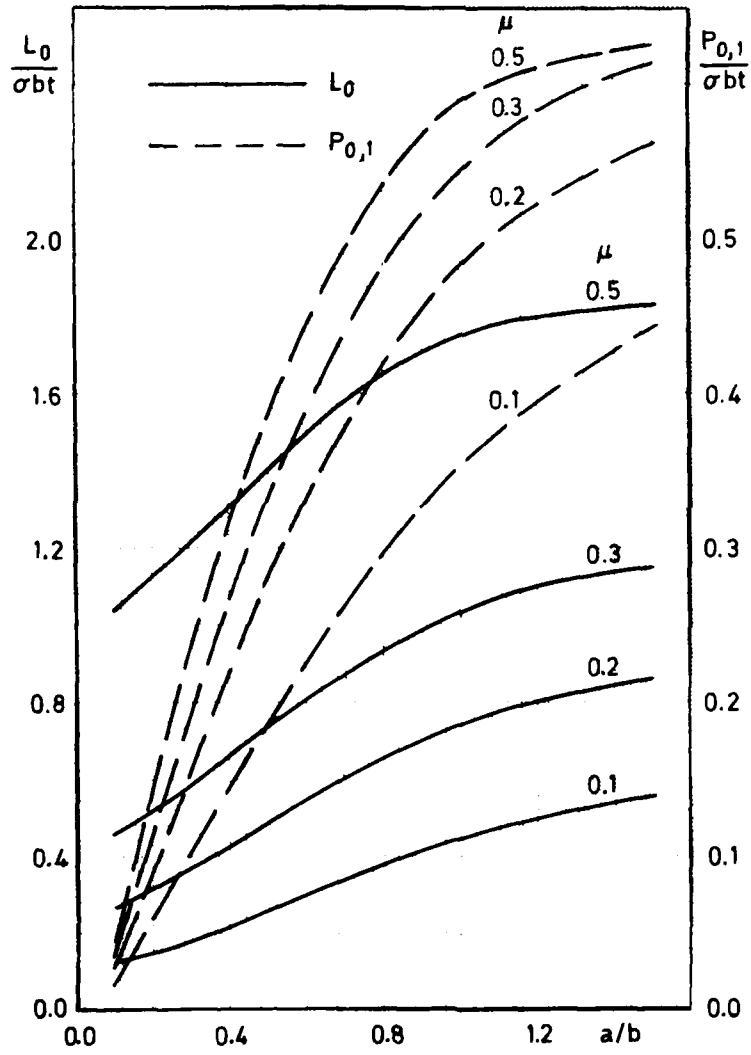

Fig 12 Load concentration and first attachment force for a central unbroken stiffener:  
 $\rho/b = 1/3$

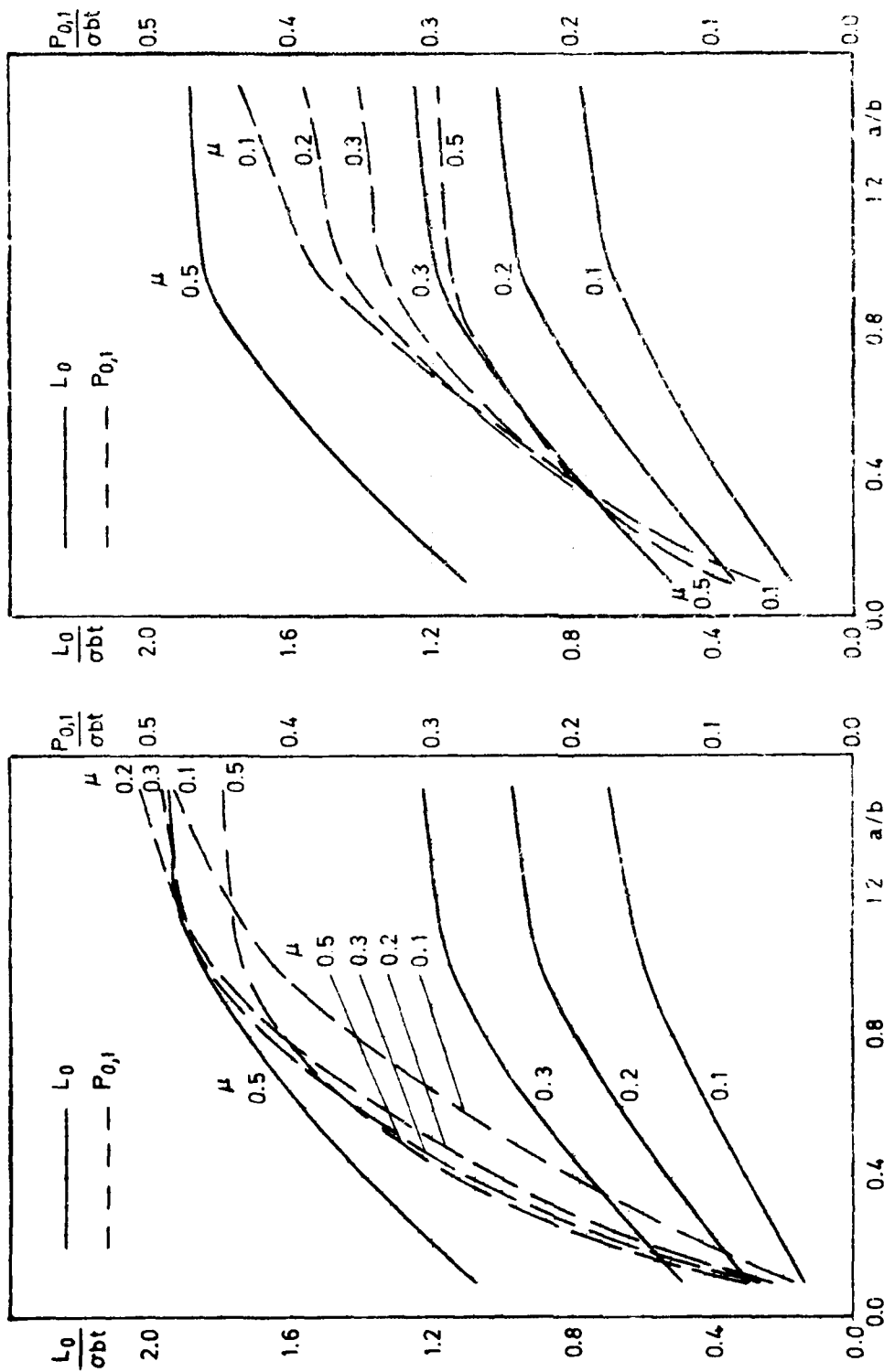

Fig 13  $p/b = 1/6$

Fig 14  $p/b = 1/12$

Figs 13&14

Figs 13&14 Load concentration and first attachment  $P_{0,1}$  for a central unbroken stiffener.  $p/b = 1/6$  and  $1/12$

Fig 15

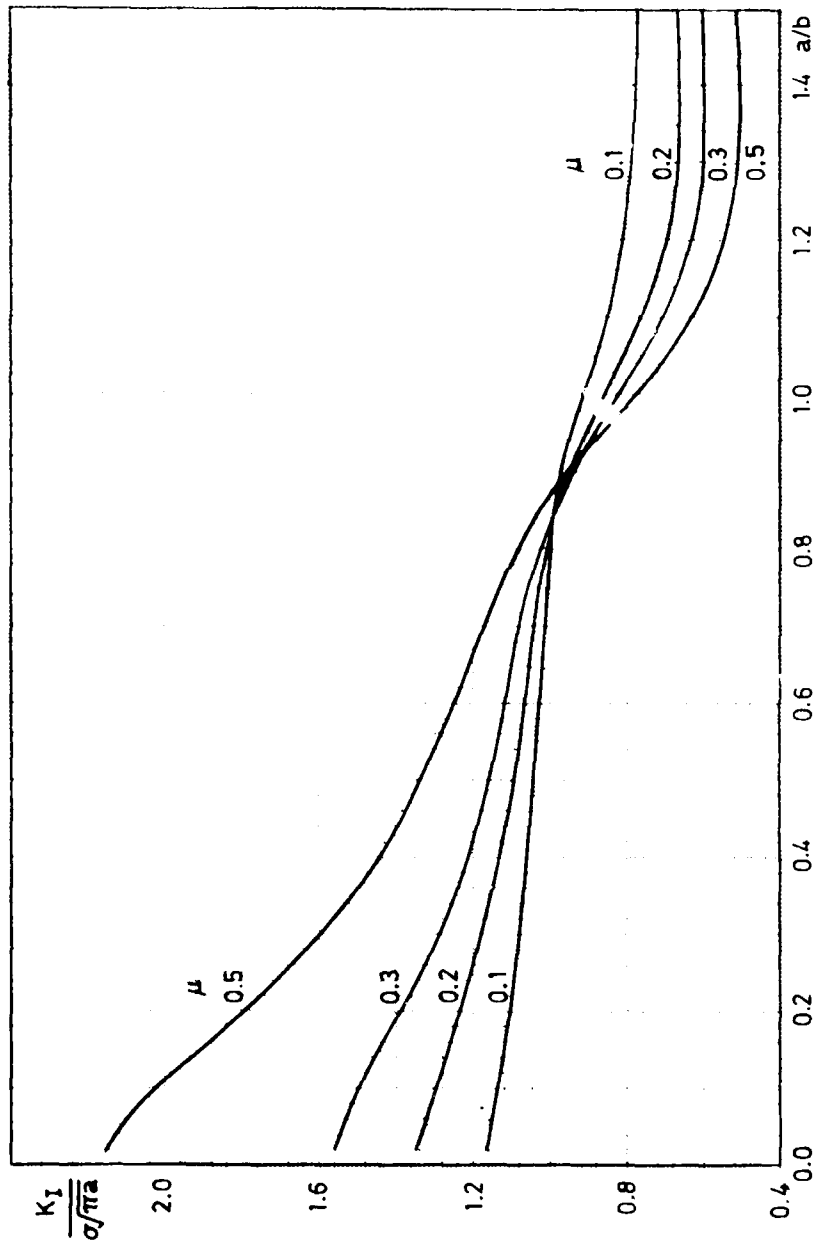

Fig 15 Stress intensity factors for a crack centred on a broken stiffener:  $p/b = 1/3$

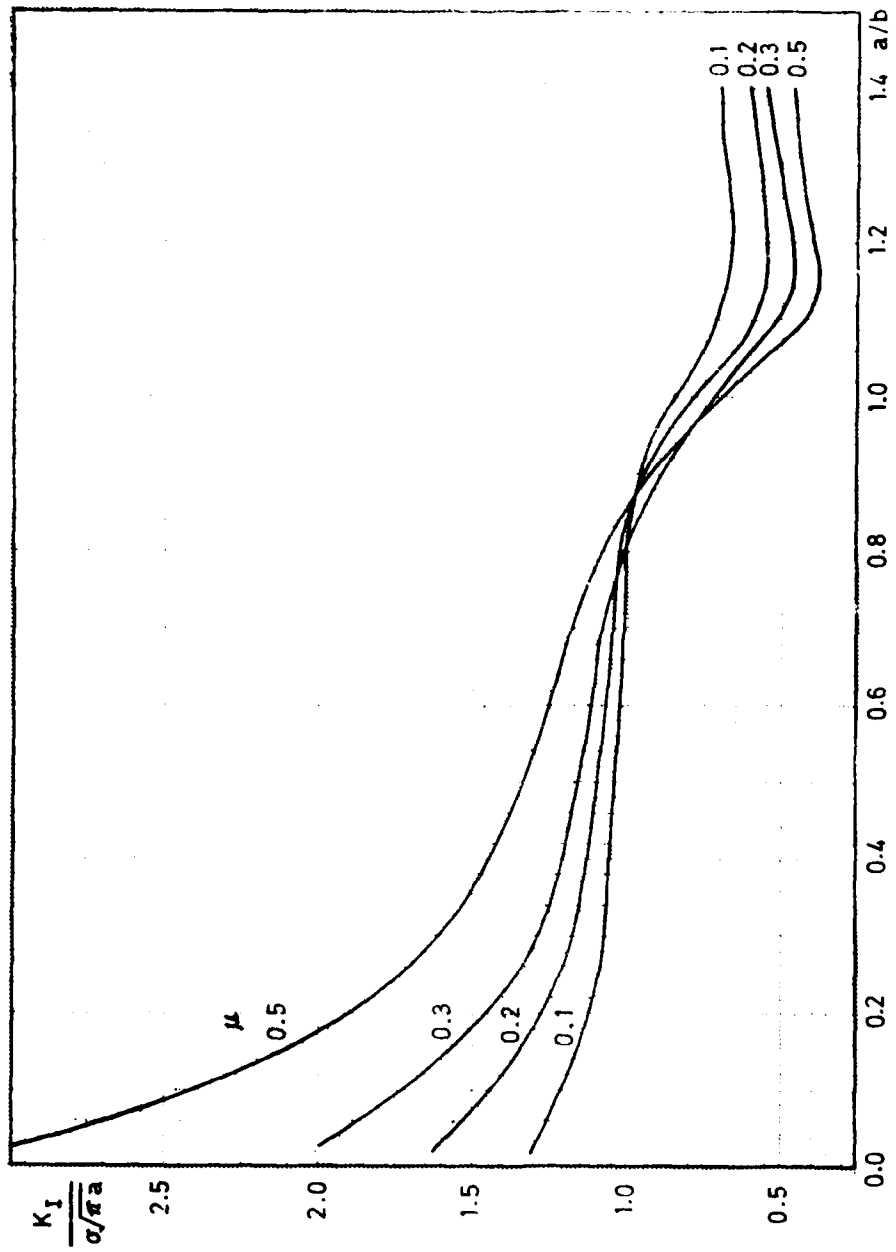

Fig 16 Stress intensity factors for a crack centred on a broken stiffener.  $p/b = 1/6$

Fig 17

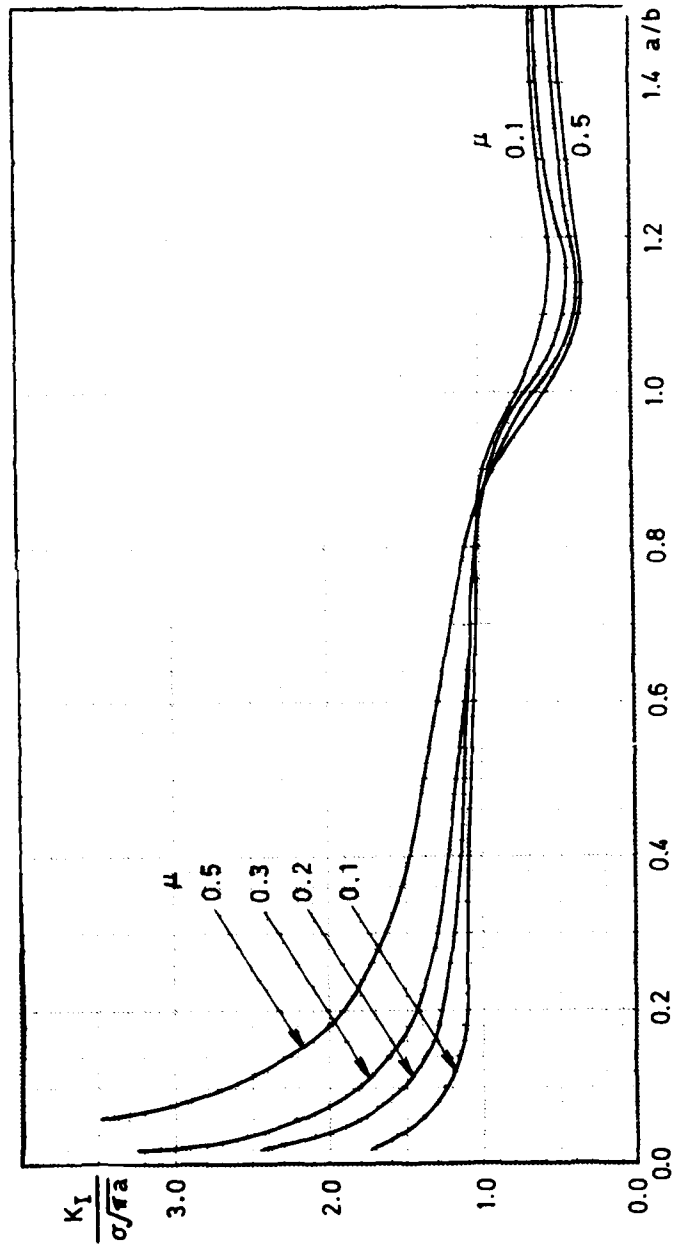

Fig 17 Stress intensity factors for a crack centred on a broken stiffener:  $p/b = 1/12$

Fig 18

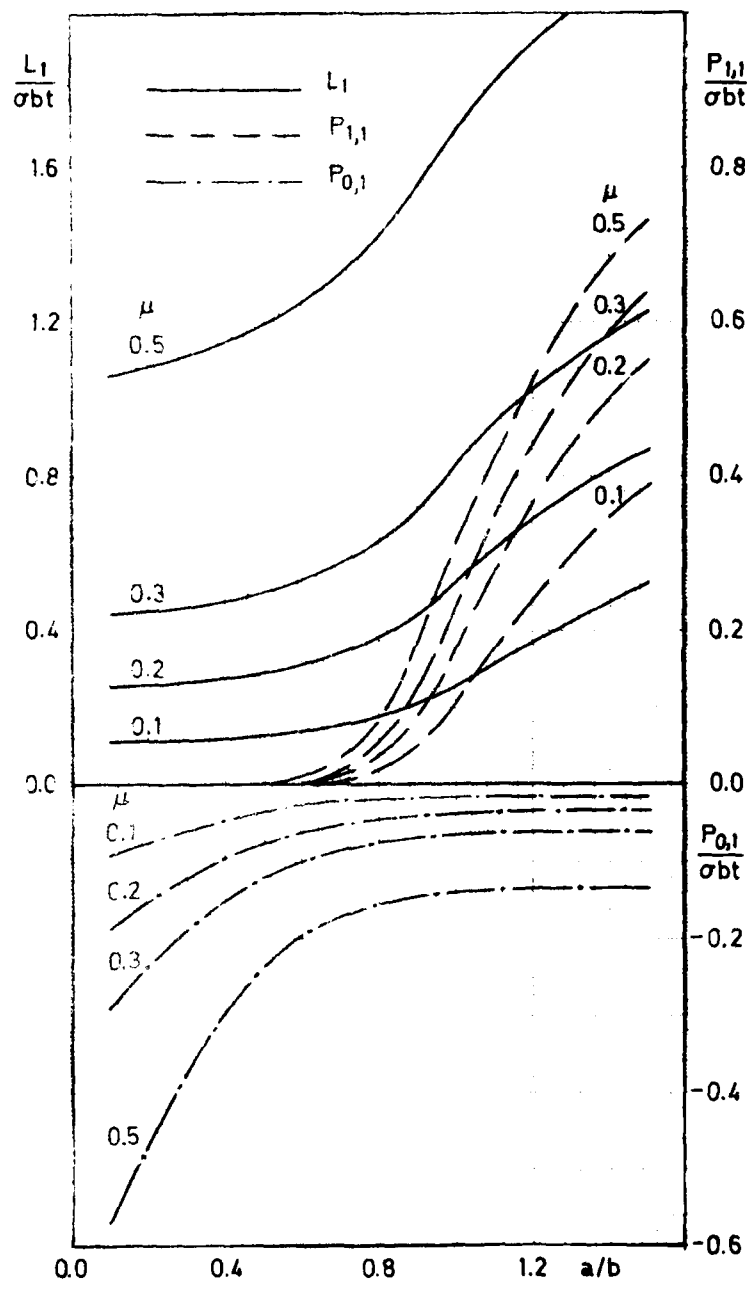

Fig 18 Force at the first attachment in a central broken stiffener and the load concentration and first attachment force in the adjacent pair of stiffeners:  $p/b = 1/3$

TR 80122

Fig 19

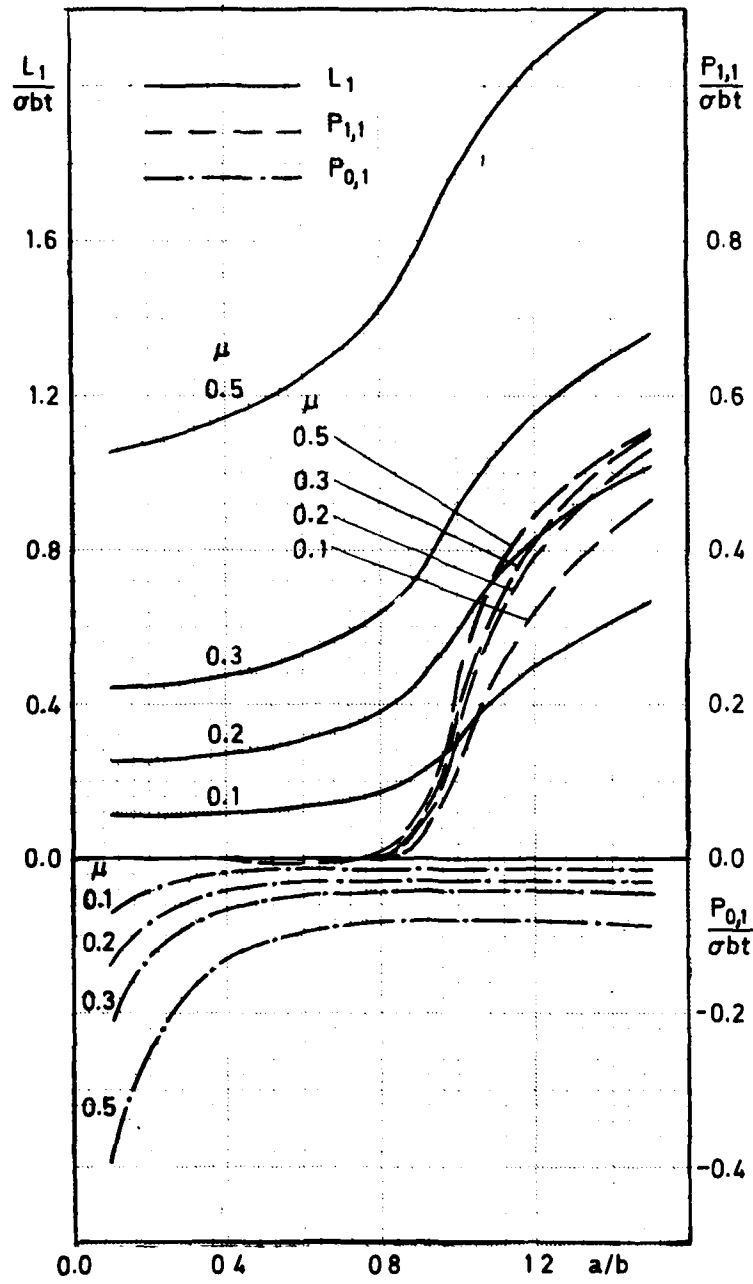

Fig 19 Force at the first attachment in a central broken stiffener and the load concentration and first attachment force in the adjacent pair of stiffeners:  $p/b = 1/6$

Fig 20

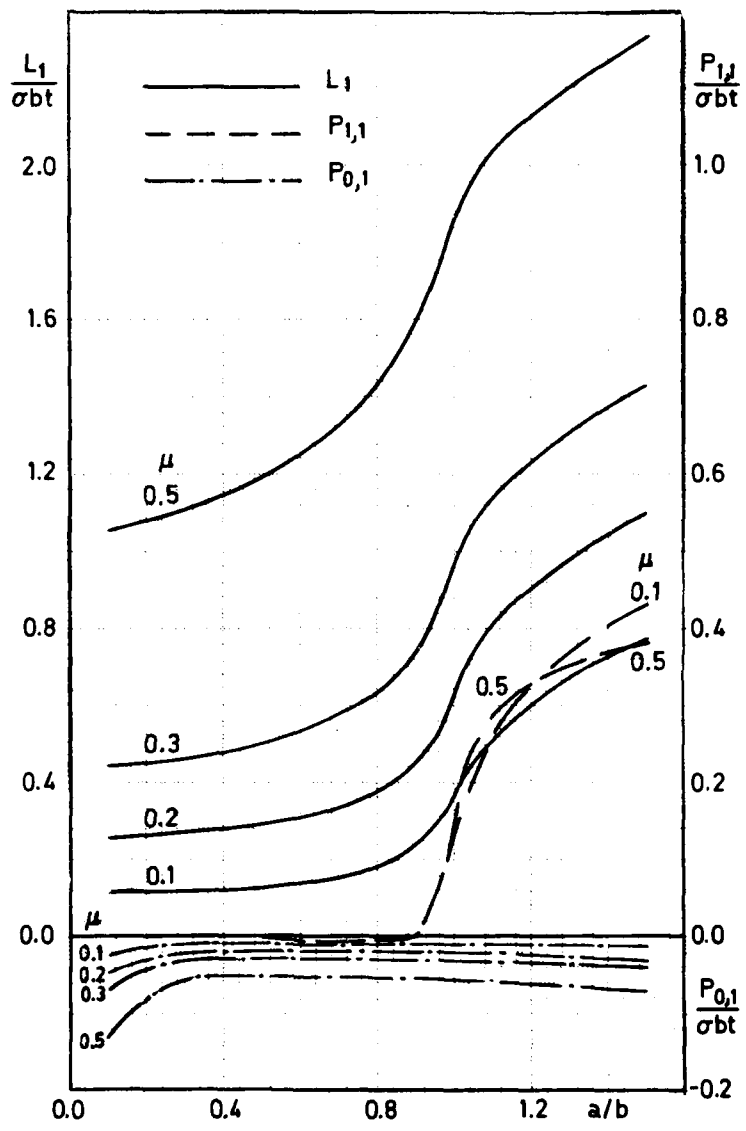

Fig 20 Force at the first attachment in a central broken stiffener and the load concentration and the first attachment force in the adjacent pair of stiffeners.  $p/b = 1/12$



END

DATE  
FILMED

5 81

DTIC