

AD-A097 627

YALE UNIV NEW HAVEN CT SYSTEMS AND INFORMATION SCIENCES F/6 12/1
THE STABILITY OF SECOND ORDER QUADRATIC DIFFERENTIAL EQUATIONS.--ETC (11)
DEC 80 D E KODITSCHER, K S NARENDRA N00014-76-C-0017
S/IS-8004 NL

UNCLASSIFIED

[OF]
AN
00000007



END
DATE
FILMED
5 81
DTIC

12



LEVEL

SYSTEMS AND INFORMATION SCIENCES

AD A 0 97 183 4



DTIC
APR 9 1981

DISTRIBUTION STATEMENT A
Approved for public release;
Distribution Unlimited

DTIC FILE COPY

DEPARTMENT OF ENGINEERING
AND APPLIED SCIENCE
YALE UNIVERSITY
NEW HAVEN, CONNECTICUT

13

DTIC
REFLECTOR
APR 3 1981

6

THE STABILITY OF SECOND ORDER
QUADRATIC DIFFERENTIAL EQUATIONS.

PART III

10

Daniel E. / Koditschek ~~and~~ Kumpati S. / Narendra

13

Contract NO0014-76-C-0017
S & IS Report No. 8004

11

December, 1980

12) 45

14) S/IS-8004

DISTRIBUTION STATEMENT A
Approved for public release;
Distribution Unlimited

4102,13 81 2 10 020

-12

The Stability of Second Order
Quadratic Differential Equations

Daniel E. Koditschek and Kumpati S. Narendra
Department of Engineering and Applied Science
Yale University

Abstract: This paper investigates the stability properties of second order systems, $\dot{x} = f(x)$, where $f(x)$ contains either quadratic terms -system (1)- or linear and quadratic terms -system (2)-in x . The principal contributions are summarized in two theorems which give necessary and sufficient conditions for stability and asymptotic stability in the large of systems (1) and (2) respectively.

Accession For	<input checked="" type="checkbox"/>
NTIS GRA&I	
DTIC TAB	
Unannounced	
Justification	<i>for file</i>
By	<i>[Signature]</i>
Distribution/	
Availability Codes	
Dist	Avail and/or Special
A	

The Stability of Second Order
Quadratic Differential Equations

Daniel E. Koditschek and Kumpati S. Narendra

1. Introduction:

The diverse behavior of nonlinear systems reflects the obvious fact that no one theory can address all phenomena of interest. Powerful techniques have evolved over the years in the context of specific questions regarding particular classes of such systems. This paper suggests a useful approach to the investigation of the stability characteristics of a class of second order differential equations:

$$\dot{x} \triangleq \begin{bmatrix} \dot{x}_1 \\ \dot{x}_2 \end{bmatrix} = \begin{bmatrix} x^T G x \\ x^T H x \end{bmatrix} \triangleq B(x) \quad (1)$$

and

$$\dot{x} = Ax + B(x) \quad (2)$$

More than a convenient choice of systems, quadratic differential equations have a traditional and increasing importance in stability literature. Given a general autonomous differential equation $\dot{x} = f(x)$, $f(x)$ can be expanded in a Taylor Series around the origin if it satisfies certain regularity conditions. If the equilibrium state of the linear approximation is asymptotically stable (unstable) it is well-known that the nonlinear system is also asymptotically stable (unstable). However, in the critical case, when the linear approximation is merely stable, interest shifts to an equation of the form (2) in the stability analysis of the nonlinear system. Differential equations of this type are known to arise in adaptive control where control parameters become state variables of a quadratic system. More recently, the special class of bilinear systems

$$\dot{x} = Ax + uDx + bu \quad (3)$$

has received a great deal of attention in the control literature and the principal results of this theory are influencing the direction of research on general nonlinear systems. When the control $u(t)$ in equation (3) is a linear function of the state variables, equation (3) becomes a special case of (2) and the stability properties of such systems are bound to be of interest to control theorists.

This paper presents necessary and sufficient conditions for stability in the large of system (1) and asymptotic stability in the large of system (2). A brief treatment of some interesting properties of general homogeneous differential equations in section 2 provides the setting for the results on pure quadratic systems developed in section 3. A simple statement of conditions for the stability of system (1) is given by Theorem 1 at the end of that section. While the qualitative behavior of (1) can be completely characterized using a few simple prototypes [1] the addition of the linear part in (2) results in much more varied behavior: a simple classification will not be complete; a complete classification will not be simple. Consequently, we limit our interest to one important aspect of the stability behavior of (2) - asymptotic stability in the large (a.s.l.). Yet even within this restricted scope, only necessary or sufficient conditions for a.s.l. are amenable to simple presentation. A complete account is seen in section 4 to involve a variety of special cases. The resulting statement of necessary and sufficient conditions for a.s.l. is given by Theorem 2 at the end of that section.

2. Homogeneous Systems of Even Degree:

Consider a dynamical system in \mathbb{R}^n :

$$\dot{x} = h(x) \quad (4)$$

where $h(x)$ is a homogeneous function such that $h(\beta x) = \beta^k h(x)$, $\beta \in \mathbb{R}$ $k \geq 1$. If k is even the direction of the field is a constant along any straight line through

the origin. A well-known but useful fact concerning solutions of (4) is given by the following lemma.

Lemma 2.1: Let $p(t; x_0)$ be a solution of (4) given initial condition $p(0; x_0) = x_0$. Then for all $\beta \in \mathbb{R}$

$$p(t; \beta x_0) = \beta p(\beta^{k-1} t; x_0)$$

Proof: Let $t = \beta^{k-1} s$ and define $u(s) \triangleq \beta p[t(s); x_0]$.

$$\begin{aligned} \text{Then } \frac{d}{ds} u(s) &= \beta \frac{d}{dt} p(t; x_0) \frac{dt}{ds} = \beta^k \frac{d}{dt} p(t; x_0) \\ &= h(u) \end{aligned}$$

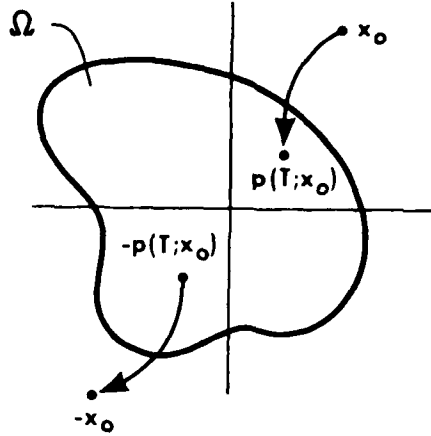

Figure 1. Reflection Property of Even Homogeneous System

Hence $u(s)$ satisfies (4) with initial condition $u(0) = \beta x_0$ as does $p(t; \beta x_0)$ which implies $u(s) = p(t; \beta x_0)$. \square

If k is even then this relationship implies $p(t; -x_0) = -p(-t; x_0)$. In other words any trajectory through x_0 for $t \geq 0$ has an associated trajectory through $-x_0$ for $t \leq 0$ which is its reflection. This simple fact, depicted in Figure 1, leads to the following corollary.

Corollary 2.1: If k is even and the origin is stable then for any $x_0 \neq 0$ the complete trajectory $\gamma(x_0) \triangleq \{p(t; x_0) | t \in \mathbb{R}\}$ is a positive distance from the origin.

Proof: Let $\|x_0\| > \epsilon > 0$ but let the positive trajectory not be bounded away from the origin. Then there exists a sequence $\{t_n\}_{n \geq 1}$, $t_n > 0$ such that $\|p(t_n; x_0)\| < \frac{1}{n}$

Defining $x_n \triangleq p(t_n; x_0)$ we have $p(t_n; -x_n) = -x_0$ from Lemma 2.1. Hence for no $n > 0$ does $\|x_n\| < \frac{1}{n}$ imply $\|p(t; -x_n)\| \leq \epsilon$ and the origin is unstable. A similar argument applies to the negative trajectory. \square

In general, Corollary 2.1 indicates that an even degree homogeneous dynamical system in \mathbb{R}^n can never be asymptotically stable. On the plane, \mathbb{R}^2 , we may say

even more. Equation (1) is a specific example of (4) in \mathbb{R}^2 for which $k = 2$. The remainder of this paper will be devoted to the study of (1) and (2) in \mathbb{R}^2 .

Lemma 2.2: No solution of system (1) other than an equilibrium point can be a closed path.

Proof: This follows directly from the fact that any nontrivial closed curve will intersect some line through the origin at least twice. A trajectory on this curve would imply that the field changes direction along that line which violates the even homogeneous property of (1). \square

Corollary 2.2: If the origin of system (1) is stable then the field must vanish along at least an entire line through the origin.

Proof: It suffices to show that an equilibrium state $x_0 \neq 0$ exists. By homogeneity the conclusion follows.

Let $\gamma \neq 0$ be a trajectory of (1) contained in some compact neighborhood of 0. From Corollary 2.1 $0 \notin \bar{\gamma}$ where $\bar{\gamma}$ is the closure of γ . From Lemma 2.2 γ is not a non-trivial closed path. Hence by Poincare-Bendixson Theorem the limit set of γ is a singular point x_0 of B. Since $x_0 \neq 0$ we have $B(x) = 0$ for all $x = \alpha x_0$, $\alpha \in \mathbb{R}$ by homogeneity. \square

The next section will investigate the existence of lines along which the field in (1) vanishes as required by the previous corollary, leading to a new parametrization of stable quadratic systems. This new parametrization allows the characterization of stability behavior in terms of a matrix in $\mathbb{R}^{2 \times 2}$, a result whose consequences pervade the remainder of this paper. Indeed, concerning the final section of the paper, the availability of this linear form can safely be said to make a seemingly hopeless task complicated but possible.

3. Stability of Second Order Quadratic Systems:

In this section we shall exclusively consider the particular class of second degree second order systems described by (1)

$$\dot{x} = \begin{bmatrix} x^T G x \\ x^T H x \end{bmatrix} \triangleq B(x) \quad (1)$$

We assume that at least one of either G or $H \in \mathbb{R}^{2 \times 2}$ is non-zero and, without loss of generality, that both are symmetric. From Corollary 2.2 it follows that the locus of the set of critical points of $B(x)$ is crucial to the stability properties of (1). This is completely determined by G and H , and using familiar properties of symmetric matrices we may classify the types of equilibrium states evinced by (1) according to whether the field vanishes.

- (i) only at the origin
- (ii) along a straight line through the origin
- (iii) along two straight lines through the origin.

Table I provides examples of each type of quadratic field based upon the familiar rank and signature properties of G and H . The reader may note that as an immediate consequence of Corollary 2.2, systems of type (i) cannot be stable - in the terms of Table I only systems like those given by examples 2b, 2c, 3b, or 4b may be stable. The remainder of this section is devoted to refining this necessary condition.

a. Notation and Definitions:

Since indefinite and semi-definite matrices will arise in all subsequent discussions it is worth establishing the following notational conventions concerning their algebraic and geometric properties. Let A_s denote the symmetric part of A . The set $S[A] \triangleq \{M | A_s = M_s\}$ denotes the symmetric equivalence class of A . Clearly, $x^T M x = x^T A x \quad \forall x \in \mathbb{R}^2$ if and only if $M \in S[A]$. If $A = ab^T$ is singular and $P \in S[A]$ then $x^T P x = 0$ iff x is orthogonal to either a or b .

TABLE I

<u>Properties of G & H</u>	<u>Type</u>	<u>Example</u>	
1. G or H definite	Type (i)	$G = \begin{bmatrix} 1 & 0 \\ 0 & 1 \end{bmatrix}$	$H = \begin{bmatrix} 1 & 0 \\ 0 & -1 \end{bmatrix}$
2. a) G and H indefinite and of full rank.	Type (i)	$G = \begin{bmatrix} 0 & 1 \\ 1 & 0 \end{bmatrix}$	$H = \begin{bmatrix} 1 & 0 \\ 0 & -1 \end{bmatrix}$
b) G and H indefinite and of full rank.	Type (ii)	"	$H = \begin{bmatrix} 1 & 1/2 \\ 1/2 & 0 \end{bmatrix}$
c) G and H indefinite and of full rank.	Type (iii)	"	$H = \begin{bmatrix} 0 & 2 \\ 2 & 0 \end{bmatrix}$
3. G singular H indefinite and of full rank.			
a) $Gx = 0 \quad x^T Hx \neq 0$	Type (i)	$G = \begin{bmatrix} 1 & 1 \\ 1 & 1 \end{bmatrix}$	$H = \begin{bmatrix} 0 & 1/2 \\ 1/2 & 0 \end{bmatrix}$
b) $Gx = 0 \quad x^T Hx = 0$	Type (ii)	$G = \begin{bmatrix} 1 & 0 \\ 0 & 0 \end{bmatrix}$	$H = \begin{bmatrix} 0 & 1/2 \\ 1/2 & 0 \end{bmatrix}$
4. G and H singular			
a) $G \neq \alpha H$	Type (i)	$G = \begin{bmatrix} 1 & 0 \\ 0 & 0 \end{bmatrix};$	$H = \begin{bmatrix} 0 & 0 \\ 0 & 1 \end{bmatrix}$
b) $G = \alpha H$	Type (ii)	$G = \begin{bmatrix} 1 & 0 \\ 0 & 0 \end{bmatrix};$	$H = \begin{bmatrix} -1 & 0 \\ 0 & 0 \end{bmatrix}$

The class $S[0]$ contains a matrix J with the property $J^2 = -I$. J is the skew-symmetric matrix $\begin{bmatrix} 0 & -1 \\ 1 & 0 \end{bmatrix}$ (or $\begin{bmatrix} 0 & 1 \\ -1 & 0 \end{bmatrix}$) and maps every vector in \mathbb{R}^2 into its orthogonal complement in the counterclockwise (clockwise) sense - i.e. $x_{\perp} \triangleq Jx$. From these definitions it follows that (i) $x^T x_{\perp} = 0 \quad \forall x \in \mathbb{R}^2$; (ii) $x^T y_{\perp} = 0$ iff $x = \alpha y \quad \alpha \in \mathbb{R}$; (iii) For $J = \begin{bmatrix} 0 & -1 \\ 1 & 0 \end{bmatrix}$ $x^T y_{\perp} = x^T Jy = |y, x|$ where the last symbol denotes the determinant of the array $[y, x]$.

Finally, the following conventions will facilitate further discussion involving some natural geometric objects defined by vectors and matrices in \mathbb{R}^2 . We denote the subspace defined by $x \in \mathbb{R}^2$ as $|(x) \triangleq \{y | y = \alpha x, \alpha \in \mathbb{R}\}$, its orthogonal complement as ${}^{\perp}(x) \triangleq \{y | y^T x = 0\}$ and its positive affine half plane as $H_{\eta}(x) \triangleq \{y | x^T y > \eta\}$ for $\eta \in \mathbb{R}$. If P is a symmetric indefinite or semi-definite matrix then its positive cone is defined as $C_{\gamma}(P) \triangleq \{x | x^T P x > \gamma\}$ for $\gamma \in \mathbb{R}$. If $O \subseteq \mathbb{R}^2$ is disconnected [4, p. 152] then there exists a pair of open sets O_1, O_2 such that $O = O_1 \cup O_2$ and $O_1 \cap O_2 = \emptyset$ called a separation of O . The set O_1 is said to separate O and separates improperly when $O_2 = \emptyset$.

b. Quadratic Differential Equations with Non-Isolated Equilibria:

These considerations allow an immediate re-parametrization of system (1) with non-unique equilibria.

Lemma 3.1: System (1) is type (ii) or (iii) if and only if there is some $c \in \mathbb{R}^2$ and $D \in \mathbb{R}^{2 \times 2}$ such that $B(x) = c^T x D x$.

Proof: $B(x)$ is type (ii) or (iii) if and only if for some $x_1 \neq 0$

$$B(x_1) = \begin{bmatrix} x_1^T G x_1 \\ x_1^T H x_1 \end{bmatrix} = 0.$$

Now $x_1^T G x_1 = 0$ if and only if $G \in S[d_1 c^T]$ where $c \in {}^{\perp}(x_1)$ and d_1 is an arbitrary point in \mathbb{R}^2 . Similarly $H \in S[d_2 c^T]$. Then, defining $D \triangleq \begin{bmatrix} d_1^T \\ d_2^T \end{bmatrix}$ we have

$$B(x) = \begin{bmatrix} x^T G x \\ x^T H x \end{bmatrix} = \begin{bmatrix} x^T c & d_1^T x \\ x^T c & d_2^T x \end{bmatrix} = c^T x D x.$$

The importance of this lemma is that it relates individual solutions of a nonlinear time invariant system to solutions of a linear time varying system

$$\dot{x} = \gamma(t)Dx$$

which, in turn, may be written as

$$\frac{dx}{ds} = Dx(s) \quad \frac{ds}{dt} = \gamma(t) \quad (5)$$

Thus, if $p(t;x_0)$ is a solution to system (1) of type (ii) or (iii) then

$$p(t;x_0) = e^{s(t)D} x_0 \quad s(t) = \int_0^t c^T p(\tau;x_0) d\tau$$

and that trajectory remains on the integral curve of system (5) specified by x_0 with position parametrized by $s(t)$. The following classification of system (5) provides the framework for the complete stability analysis of (1) and the a.s.l. analysis of (2). We will say D is focal^{*} if it has two complex conjugate eigenvalues, nodal^{*} if it has two distinct real eigenvalues, and critical^{*} if it has a unique real eigenvalue of multiplicity two. We further distinguish among the class of critical matrices those which admit only one eigenvector as opposed to an infinite number of eigenvectors. If D is critical with the unique eigenvector $x \in \mathbb{R}^2$ then we will say D is x-critical. To conclude this section we show that only focal matrices admit a stable origin of system (1).

c. Necessary and Sufficient Conditions for Stability:

To exclude all critical and nodal D matrices from further consideration we apply Chetaev's Instability Theorem [3] as follows.

Lemma 3.2: If $B(x) = c^T x D x$ and D is nodal or critical then system (1) is unstable.

Proof: Since $B(x) = (-c^T x)(-Dx)$ we assume with no loss of generality that D has an eigenvalue in \mathbb{R}^+ . Hence by Fact A.4 in Appendix A, there exists an indefinite

* Note the distinction between these classes and the traditional designation of linear systems according to whether the origin is a node, saddle, focus, or center. For instance, a focal matrix defines a linear system whose origin is either a focus or center, while a nodal matrix yields a node or saddle.

symmetric matrix P such that $c_{\perp} \notin C_0(P)$ and $C_0(P) \subseteq C_0([PD]_s)$. From Fact A.3 we have $\Omega \stackrel{\Delta}{=} H_0(c) \cap C_0(P)$ separates $C_0(P)$ as depicted in Figure 2. Thus if we define $V(x) = 1/2 x^T P x$ then $\dot{V} = c^T x + x^T P D x$, and $V^{-1}[\mathbb{R}^+] = C_0(P)$ with $\Lambda \stackrel{\Delta}{=} C_0([PD]_s) \cap H_0(c) \subseteq \dot{V}^{-1}[\mathbb{R}^+]$. Since Ω separates $V^{-1}[\mathbb{R}^+]$ we have $V(x) = 0$ for x on the boundary of Ω and $V(x) > 0$ for $x \in \Omega$. Moreover, $\Omega \subseteq \Lambda \subseteq \dot{V}^{-1}[\mathbb{R}^+]$ so we have a region where $V(x) > 0$ embedded in a region where $\dot{V}(x) > 0$ on whose boundary $V(x) = 0$ which includes the origin. The system must be unstable by Chetaev's Instability Theorem.

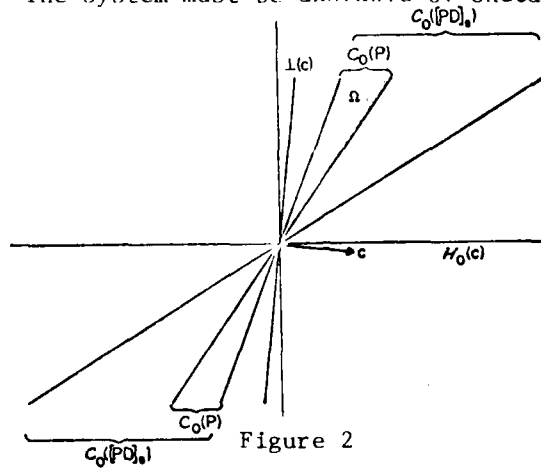

Figure 2

If D is focal then the integral curves of (5) intersect every direction on the plane at a finite point at least once. In this case all trajectories of (1) must tend eventually to $l(c)$ which must therefore contain a globally attractive invariant set. A simulation of such a system is given in Figure 3. That this situation corresponds to the stability of the origin is proven as follows.

Lemma 3.3: If $B(x) = c^T x D x$ and D is focal then (1) is stable.

Proof: If D is focal then $\sigma(D) = \{\alpha + i\beta, \alpha - i\beta\}$ $\alpha, \beta \in \mathbb{R}, \beta \neq 0$. Hence, for $t_1 = \beta/2\pi$, the natural frequency of linear system (6), we know $e^{Dt_1} x_0 \in l(x_0)$. From section 3.b we have

$$p(t; x_0) = e^{Ds(t)} x_0 \quad s(t) = \int_0^t c^T p(\tau; x_0) d\tau \neq 0 \text{ for } x_0 \notin l(c).$$

Thus, if for some $t^* \in \mathbb{R}$ $s(t^*) = t_1$ then $p(t^*; x_0) \in l(x_0)$ violating the homogeneity argument in section 2 which constrains all solutions of (1) to lie strictly within

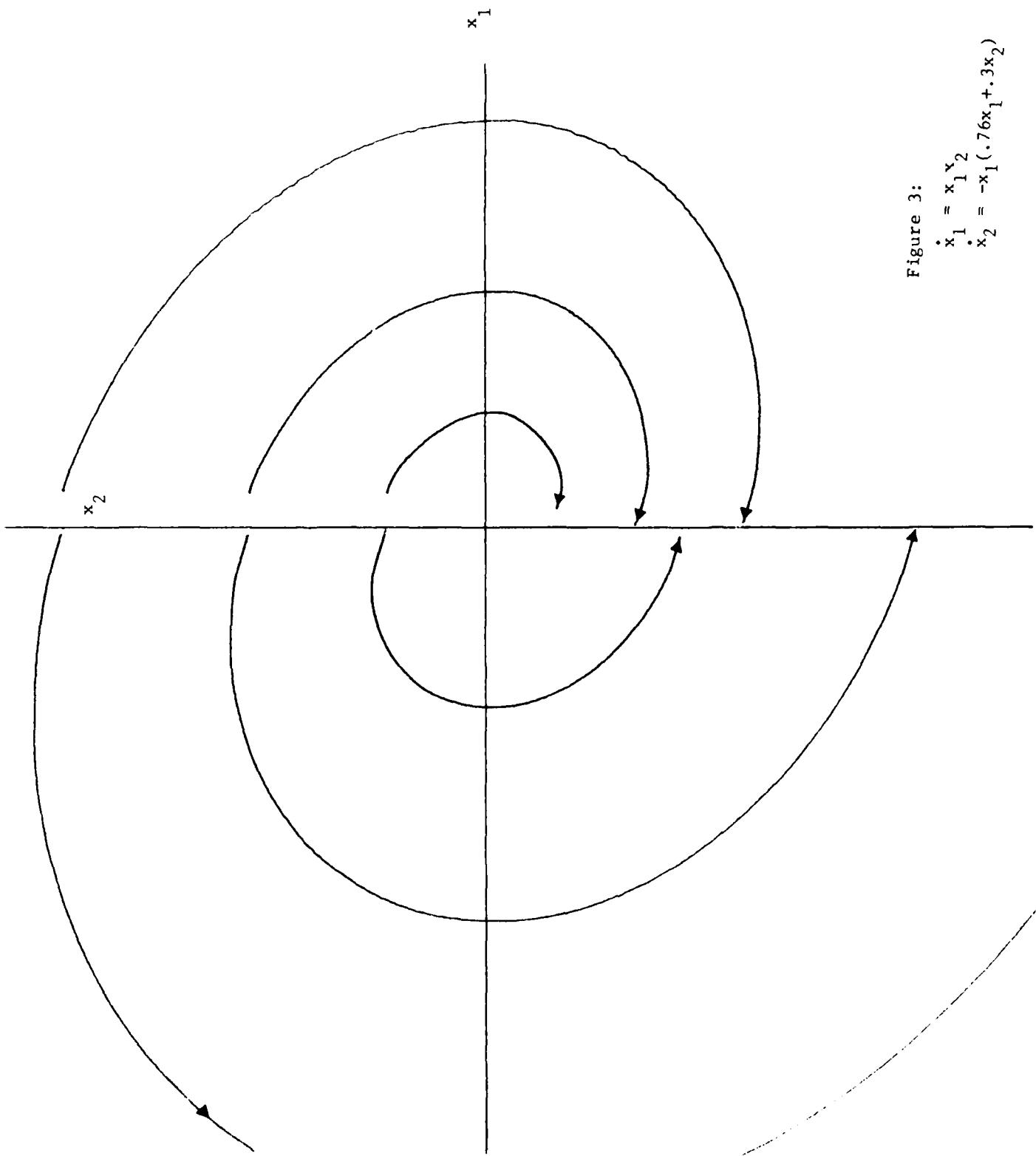

Figure 3:

$$\begin{aligned} \dot{x}_1 &= x_1 x_2 \\ \dot{x}_2 &= -x_1(.76x_1 + .3x_2) \end{aligned}$$

one half-plane of \mathbb{R}^2 . This implies $s(t) \in (-t_1, t_1) \forall t \in \mathbb{R}$. Then if

$\gamma = \sup_{t \in (-t_1, t_1)} \|e^{Dt}\|$ we have

$$\|p(t; x_0)\| \leq \|e^{Ds(t)}\| \cdot \|x_0\| \leq \gamma \|x_0\|$$

and the system is stable. \square

On the basis of Lemmas 3.1-3 we may state the principal result of this section.

Theorem 1: System (1) is stable in the large if and only if $B(x) = c^T x D x$ and D is focal.

Proof: By Lemma 3.1 system (1) is not stable unless $B(x) = c^T x D x$. By Lemmas 3.2 and 3.3, $\dot{x} = c^T x D x$ is stable if and only if D is focal. By Lemma 2.1 if (1) is stable it is stable in the large. \square

d. Summary:

The results of this section indicate that most second order quadratic differential equations are unstable: Only those systems whose solutions lie on the integral curves of a linear system whose equilibrium state is a center or a focus may be stable. An exhaustive account of the qualitative behavior of the far more pervasive unstable examples of system (1) is given in [1]. Since this paper is concerned solely with questions of stability, we are content here to ignore those results and immediately apply the techniques used in the proof of Theorem 1 to the problem of a.s.l. for system (2).

4. Asymptotic Stability in the Large of System (2): $\dot{x} = Ax + B(x)$

As mentioned in the introduction, the addition of the linear part in equation (2)

$$\dot{x} = Ax + B(x) \tag{2}$$

results in such diversity of behavior that we confine our attention exclusively to one question - the a.s.l. of equation (2). In spite of this limited range, the

complexity of the system is such that several special cases have to be considered before a complete solution can be presented. For ease of exposition necessary conditions are derived in section 4.b and conservative sufficient conditions are stated in section 4.c. Consideration of special cases in 4.d to which the results of sections 4.b and 4.c do not apply permit the proof of Theorem 2 which contains necessary and sufficient conditions for the a.s.l. of system (2).

a. Preliminary Discussion:

The existence of a positive-invariant set disconnected from the origin is a sufficient condition for the equilibrium state of system (2) not to be globally asymptotically stable. A systematic study of conditions for the existence of such sets, using Propositions 4.1 and 4.2, leads to the necessary conditions of section 4.b as well as allowing the classification of special cases in section 4.d.

Proposition 4.1 concerns the existence of an equilibrium state removed from the origin (hereafter referred to as an off-origin equilibrium), while Proposition 4.2 introduces a device used to demonstrate the existence of general positive invariant sets.

Proposition 4.1: System (2) has an equilibrium state $x_e \neq 0$ if and only if for some $x \in \mathbb{R}^2 \setminus \{x_e\}$ and $x \neq 0$ either $Ax = B(x) = 0$ or $Ax \neq 0, B(x) \neq 0$ and $B(x) \in \mathbb{R}^2 \setminus \{Ax\}$.

Proof: The proof follows directly from the fact that x_e is an equilibrium state if and only if the field in system (2) vanishes at x_e . \square

If on the boundary of an open set in \mathbb{R}^2 , the field is directed everywhere toward its interior then that set is positive-invariant. Proposition 4.2, an extension of the well-known Chetaev Instability Theorem, establishes this fact formally.

Proposition 4.2: Let V be a continuously differentiable functional on \mathbb{R}^2 , let $\Omega \neq \emptyset$ separate $V^{-1}[\mathbb{R}^+]$ and let $\dot{x} = f(x)$ admit a unique solution on Ω . If $\Omega \subseteq V^{-1}[\mathbb{R}^+]$ then Ω is a positive invariant set.

The proof follows by contradiction.

Proof: Let $x_0 \in \Omega$ but $p(t; x_0) \notin \Omega$ for some $t \in \mathbb{R}^+$. Since V is continuous, $V^{-1}[\mathbb{R}^+]$ and Ω are open, hence $t^* = \inf\{t > 0 | p(t; x_0) \notin \Omega\} \neq 0$ and $p(t; x_0) \in \Omega$ for $t \in [0, t^*)$. Since Ω separates $V^{-1}[\mathbb{R}^+]$ its boundary must be a boundary of $V^{-1}[\mathbb{R}^+]$ by fact A.1 and hence $V[p(t^*; x_0)] = 0$. Then $V[p(t^*; x_0)] - V[x_0] = -V[x_0] < 0$ and for some $t_1 \in [0, t^*)$ we must have $\dot{V}[p(t_1; x_0)] < 0$. But this contradicts $p(t_1; x_0) \in \Omega \subseteq \overset{\circ}{V}^{-1}[\mathbb{R}^+]$. \square

b. Some Necessary Conditions for Asymptotic Stability in the Large:

From the results of Lyapunov it is known that a necessary condition for system (2) to be stable is that the spectrum of A be contained in the closed left half of the complex plane, $\overline{\mathbb{C}^-}$. The following two examples indicate that system (2) can be a.s.l. even when A is a stable but not asymptotically stable matrix.

Example: 4.1a:
$$\begin{aligned} \dot{x}_1 &= x_2 + .1x_1(x_1+x_2) \\ \dot{x}_2 &= -x_1 + .1x_1(x_2-x_1) \end{aligned} \quad \text{(Figure 4a)}$$

b:
$$\begin{aligned} \dot{x}_1 &= -x_1 - x_2(x_1+x_2) \\ \dot{x}_2 &= x_1(x_1+x_2) \end{aligned} \quad \text{(Figure 4b)}$$

Hence a necessary condition for a.s.l. of system (2) is that the spectrum of A belongs to $\overline{\mathbb{C}^-}$.

If the stability properties of the linear part of (2) generally determine local behavior, intuition suggests that its global behavior is determined by the quadratic part, $B(x)$. This is partially verified by the following three lemmas.

Lemma 4.1: If $|A| \neq 0$ and $B(x)$ is type (i) then system (2) has an off-origin equilibrium.

Proof: Since $x \neq 0$ implies $Ax \neq 0$ and $B(x) \neq 0$ under the hypothesis above, it suffices to show that for some $x_0 \neq 0$, $B(x_0) \in |(Ax_0)$ by Proposition 4.1.

Since $B(x) \in |(Ax)$ iff $|Ax, B(x)| = 0$, let $A = \begin{bmatrix} a_1^T \\ -\frac{1}{T} \\ a_2 \end{bmatrix}$

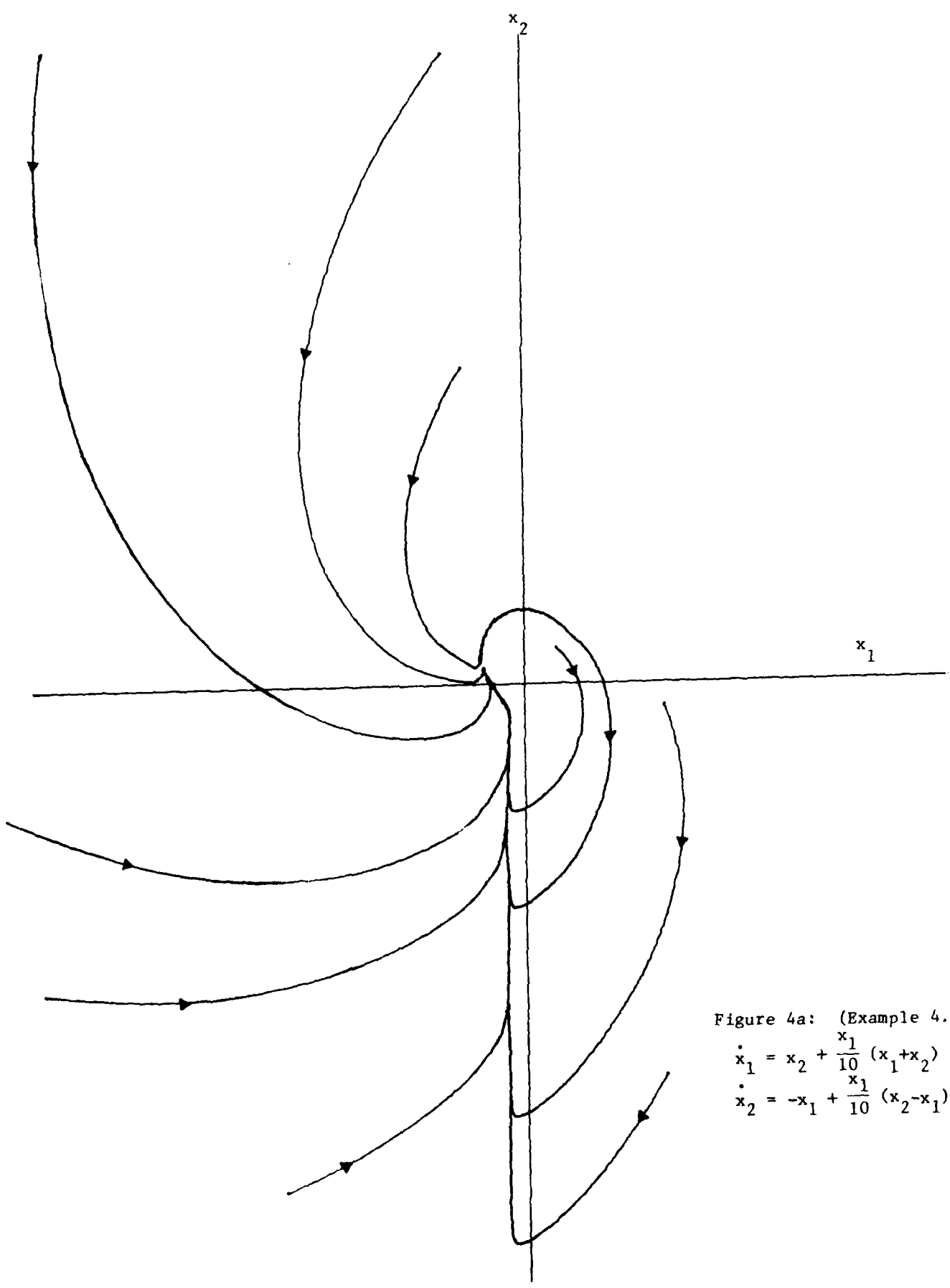

Figure 4a: (Example 4.1)
 $\dot{x}_1 = x_2 + \frac{x_1}{10} (x_1 + x_2)$
 $\dot{x}_2 = -x_1 + \frac{x_1}{10} (x_2 - x_1)$

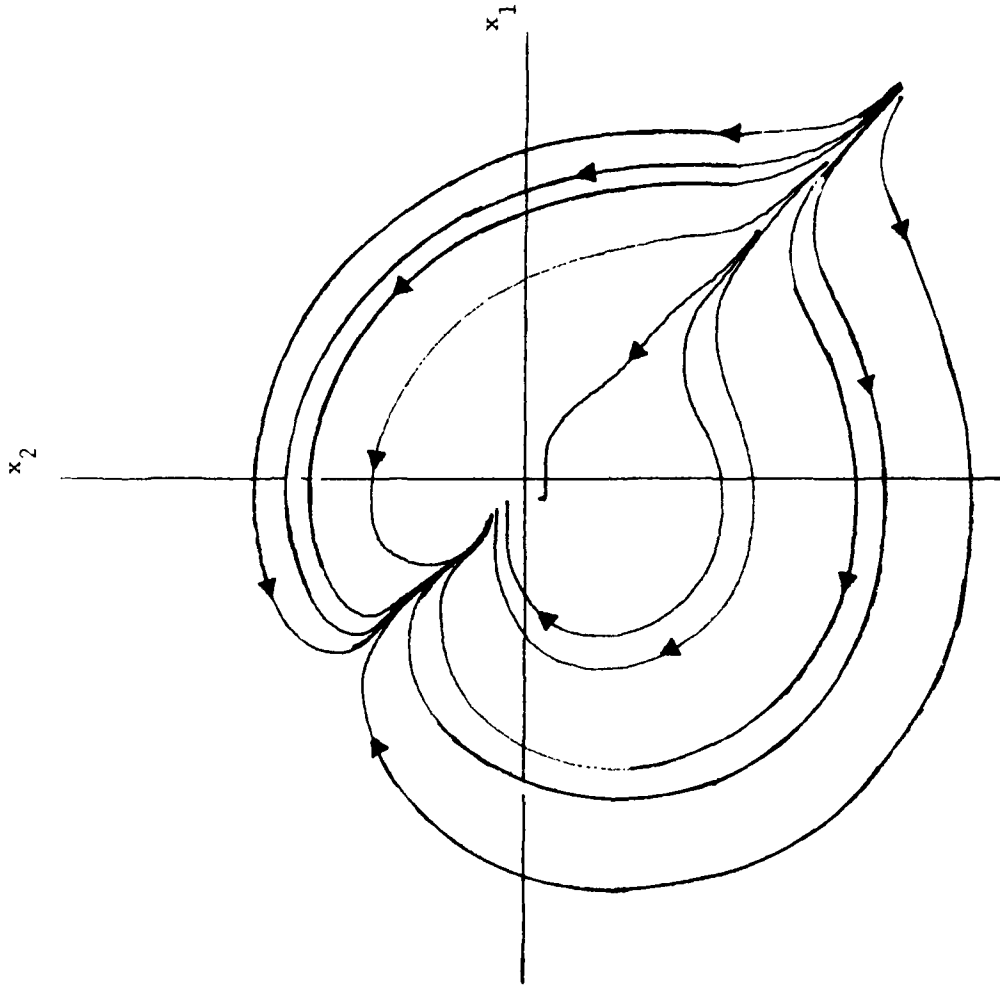

Figure 4b: (Example 4.1b)

$$\dot{x}_1 = -x_1 - x_2(x_1+x_2)$$

$$\dot{x}_2 = x_1(x_1+x_2)$$

to get $|Ax, B(x)| = \begin{vmatrix} a_1^T x & x^T Gx \\ 1 & \\ a_2^T x & x^T Hx \end{vmatrix} = x_1^3 q(x_2/x_1)$ where q is a cubic polynomial

whose leading coefficient is $a_{12}h_{22} - a_{22}g_{22} \triangleq \alpha$. If $\alpha \neq 0$, there exists a

real root v_0 of $q(v) = 0$ and hence $x_0 = \begin{bmatrix} \beta \\ \beta v_0 \end{bmatrix}$ is an equilibrium point for some $\beta \in \mathbb{R}$. If $\alpha = 0$ $|Ax_0, B(x_0)| = \begin{vmatrix} a_{12} & g_{22} \\ a_{22} & h_{22} \end{vmatrix} = 0$ for $x_0 = \begin{bmatrix} 0 \\ 1 \end{bmatrix}$. \square

Lemma 4.2: If $|A| = 0$ and $B(x)$ is type (i) then system (2) has either an unstable origin or off-origin equilibrium states.

Proof: Since A is singular, let $A = ab^T$. If there exists an x_0 such that $0 \neq x_0 \notin \perp(b)$ and $B(x_0) \in \perp(a)$ then by Proposition 4.1 the system has an off-origin equilibrium state. If for all $x \neq 0$ $B(x) \notin \perp(a)$ choose $V(x) = a_1^T x$ to get $\dot{V}(x) = a_1^T [Ax + B(x)] = a_1^T B(x) = |B(x), a|$ which is non-zero for all x . Since $B(x)$ is continuous it follows that $\dot{V}(x)$ is sign definite and since $V(x)$ can take both positive and negative values in the neighborhood of the origin, the latter is unstable. [In [2] it is shown that when $B(x) \in \perp(a)$ only for $x \in \perp(b)$ the origin is unstable]. \square

Lemmas 4.1 and 4.2 imply that $B(x) = c^T x D x$ is a necessary condition for global asymptotic stability. Following the results of section 3 one might expect an additional necessary condition requiring D to be focal. The following two examples demonstrate that system (2) can be a.s.l. even when D is not focal.

Example 4.2:

a. $\begin{bmatrix} \dot{x}_1 \\ \dot{x}_2 \end{bmatrix} = \begin{bmatrix} -1 & +1 \\ -1 & -1 \end{bmatrix} \begin{bmatrix} x_1 \\ x_2 \end{bmatrix} + x_2 \begin{bmatrix} 1 & 1 \\ 0 & 1 \end{bmatrix} \begin{bmatrix} x_1 \\ x_2 \end{bmatrix}$ (Figure 5a)

b. $\begin{bmatrix} \dot{x}_1 \\ \dot{x}_2 \end{bmatrix} = \begin{bmatrix} -1 & 0 \\ 0 & -1 \end{bmatrix} \begin{bmatrix} x_1 \\ x_2 \end{bmatrix} + x_1 \begin{bmatrix} 0 & 0 \\ 1 & 0 \end{bmatrix} \begin{bmatrix} x_1 \\ x_2 \end{bmatrix}$ (Figure 5b)

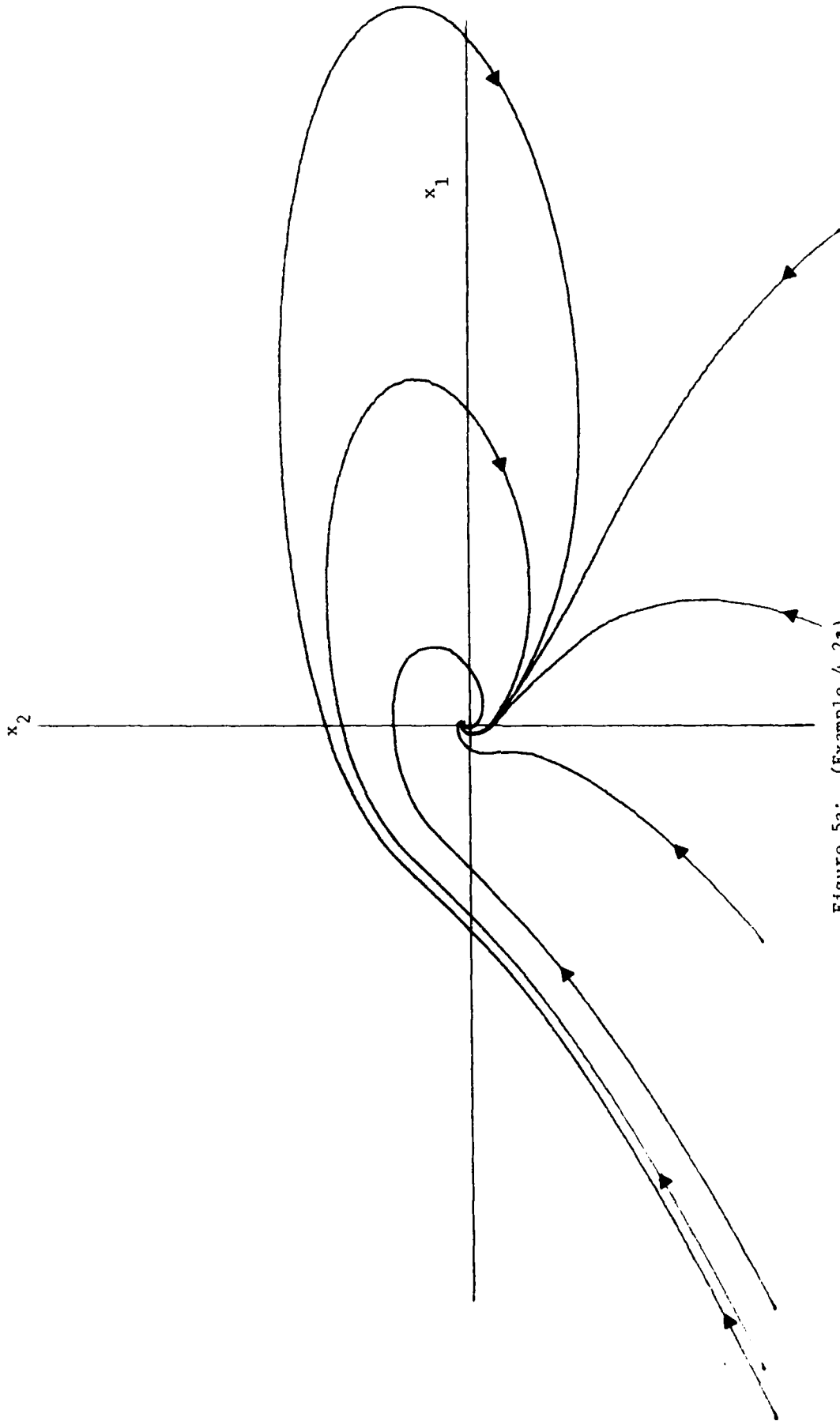

Figure 5a: (Example 4.2a)

$$\begin{aligned} \dot{x}_1 &= -x_1 + x_2 + x_2(x_1 + x_2) \\ \dot{x}_2 &= -x_1 - x_2 + x_2^2 \end{aligned}$$

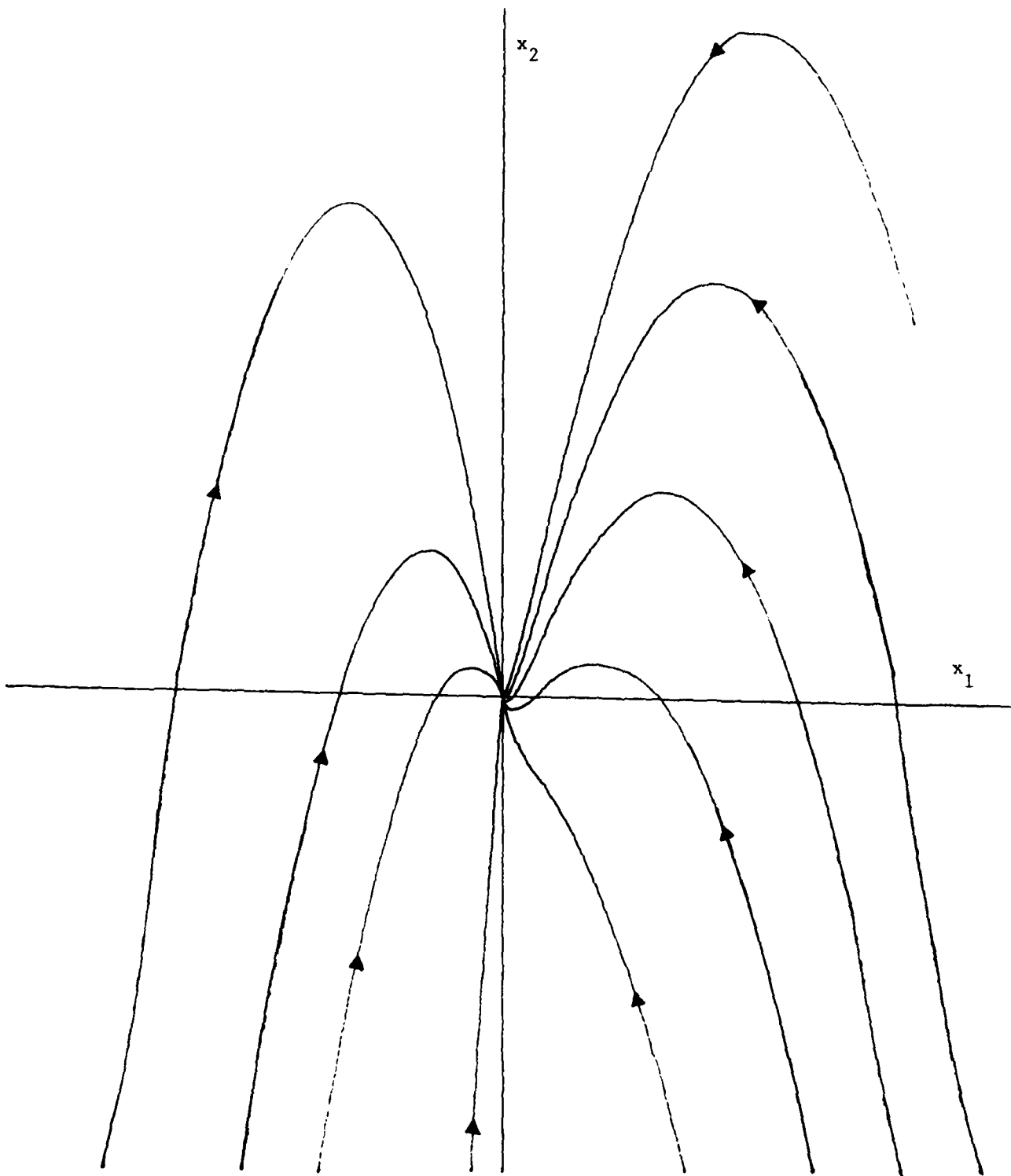

Figure 5b: (Example 4.2b)

$$\dot{x}_1 = -x_1$$

$$\dot{x}_2 = -x_2 + x_1 x_2$$

Examples 4.2a and b are a.s.l. The matrix D is critical (i.e. has an eigenvalue of multiplicity two) in both cases and is singular in case b.

When $D = db^T$ is singular $B(x) = c^T x db^T x = b^T x dc^T x$. In such a case there is an ambiguity in the parametrization of $B(x)$. If either b or $c \in \perp(d)$ then the corresponding D matrix is critical and might allow a.s.l. behavior as in example 4.2b. To resolve this ambiguity we shall classify a singular matrix D as nodal only if both parametrizations are nodal and consider only the critical parametrization otherwise.

Lemma 4.3: Let $B(x) = c^T x D x$ and let D be nodal. Then system (2) is not a.s.l.

Proof: As in the proof of Lemma 3.2 we let $\sigma(D) = \{\lambda, \mu\}$ $\lambda \geq |\mu|$ with no loss of generality and suppose $De = \lambda e$. The lemma is proved by considering the two cases $Ae \in \perp(e)$ and $Ae \notin \perp(e)$.

(i) Case $Ae \in \perp(e)$: If $e \notin \perp(c)$ then $Ae \neq 0$ implies the existence of an off-origin equilibrium by Proposition 4.1. If, however, $Ae = 0$ then since e is an eigenvector of D the equation (2) has a finite escape trajectory along $\perp(e)$ as shown in [1].

If $e \in \perp(c)$ then Proposition 4.1 does not apply. Using the change of basis $[c_\perp, c]^{-1}$ we obtain

$$\dot{y}_2 = y_2 (a_{22} + d_{22} y_2) \text{ where } d_{22} \neq 0 \text{ (since D is nodal) and the}$$

system is **unstable**.

(ii) Case $Ae \notin \perp(e)$: Choose J such that $e_\perp^T Ae > 0$.

From fact A.4 choose $P \stackrel{\Delta}{=} [e_\perp (e_\perp - \epsilon e)^T]_s$ such that

$$c_\perp \notin C_0(P) \text{ and } C_0(P) \subseteq C_0([PD]_s).^*$$

* The assumption that D is nodal is crucial here. If D is critical and non-singular then $C_0(P) \subseteq C_0([PD]_s)$ only for one orientation of J and may imply $e_\perp^T Ae < 0$ (see Appendix A). Hence the critical case is considered separately.

Define $V(x) = \frac{1}{2} x^T P x - \gamma$ where $\gamma \in \mathbb{R}^+$ and is chosen as shown below.

$\dot{V}(x) = x^T P A x + c^T x x^T P D x$ and for $x \in C_0([PD]_s)$, $\dot{V}(x) > 0$ if and only if $c^T x > \frac{\alpha(x)}{x^T P D x}$

where $\alpha(x) \triangleq -x^T P A x$. Since $\alpha(e) = -e e^T e e^T A e < 0$ (by the choice of P) α assumes negative values on $\perp(e)$ and by Fact A.5 we may choose γ such that for all

$$x \in \Omega \triangleq C_{\gamma}(P) \cap H_0(c) \subseteq C_0([PD]_s),$$

$c^T x > \frac{\alpha(x)}{x^T P D x}$ and $\Omega \subseteq \dot{V}^{-1}[\mathbb{R}^+]$. But Ω also separates $C_{\gamma}(P) = V^{-1}[\mathbb{R}^+]$ by Fact A.3.

Hence Ω is positive-invariant according to Proposition 4.2, and since $0 \notin \Omega$, the result follows. \square

Since Proposition 4.1 establishes conditions for the existence of off-origin equilibria depending upon the zeros of $|Ax, B(x)|$ we might expect $B(x) = c^T x D x$ to necessitate, in turn, $0 \neq |Ax, Dx| = |D| |D^{-1} Ax, x|$ (when $|D| \neq 0$) - i.e., that $D^{-1} A$ be focal. The following are examples of systems with $D^{-1} A$ not focal which are a.s.l.

Example 4.3: a. $\dot{x} = \begin{bmatrix} -1 & 1 \\ -1 & 0 \end{bmatrix} x + x_1 \begin{bmatrix} 0 & -1 \\ 1 & 0 \end{bmatrix} x$ (Figure 6)

b. $\dot{x} = \begin{bmatrix} -1 & 0 \\ 0 & 0 \end{bmatrix} x + (x_1 + x_2) \begin{bmatrix} 0 & -1 \\ 1 & 0 \end{bmatrix} x$ (Figure 4b)

The matrix $D^{-1} A$ is critical in both cases, and singular in 4.3b.

Lemma 4.4: If $B(x) = c^T x D x$ where D is not nodal then system (2) is not a.s.l.

when both $|A| = |D| = 0$ or either $A^{-1} D$ or $D^{-1} A$ are nodal.

Proof: $e \in \mathbb{R}^2$ is an eigenvector of $D^{-1} A$ or $A^{-1} D$ iff $B(e) \in |(Ae)$ hence if either matrix is nodal we have $B(x) \in |(Ax)$ on two distinct lines $|(e_1) \neq |(e_2)$.

Case (i) $|D| \neq 0$: Either e_1 or $e_2 \notin \perp(c)$, hence if $Ae_i \neq 0$ and $e_j \notin \perp(c)$ then the system has an off-origin equilibrium according to Proposition 4.1.

If simultaneously $Ae_1 = 0$ and $e_2 \in \perp(c)$, that is $D^{-1} A = c_1 b^T$ for some

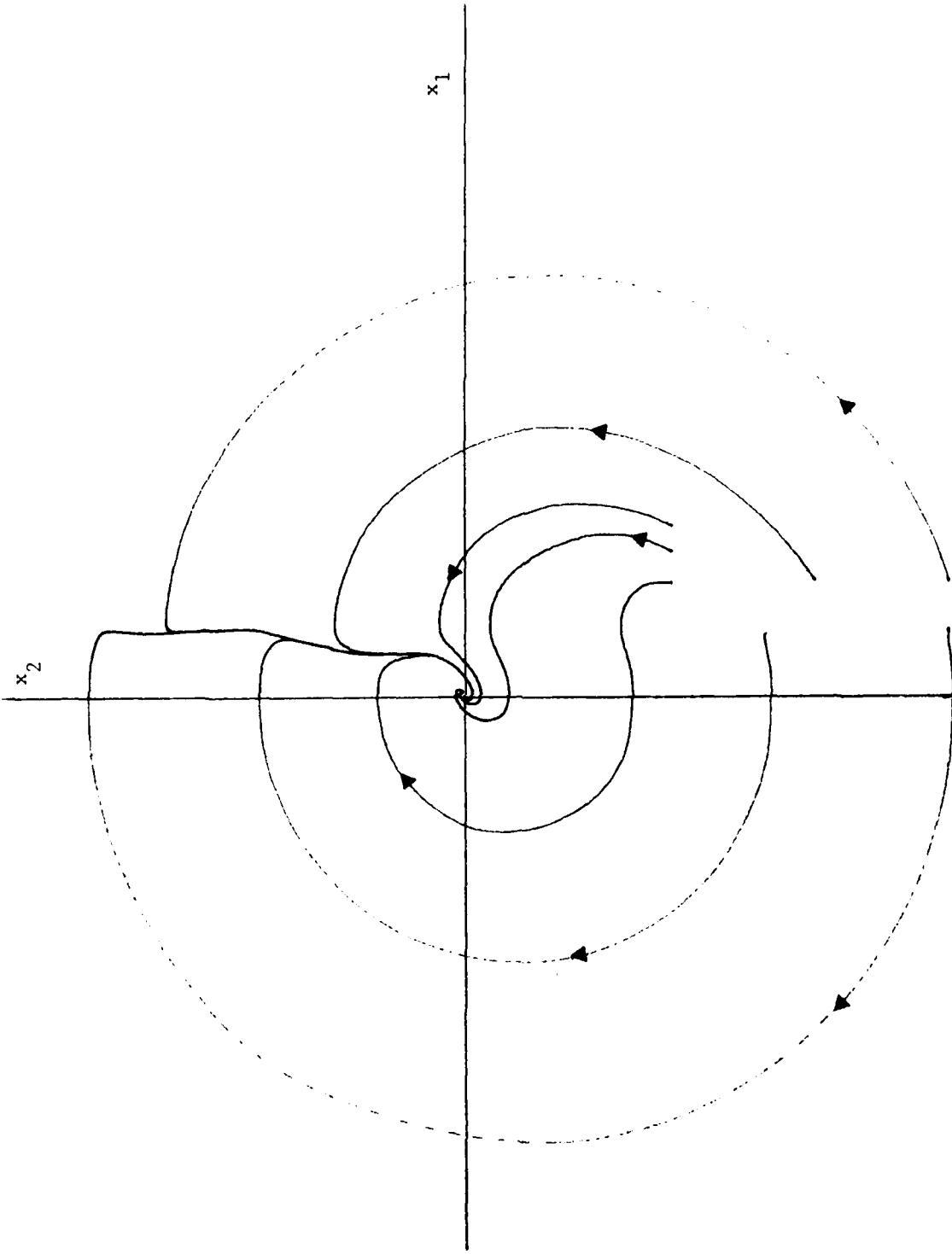

Figure 6: (Example 4.3a)

$$\begin{aligned} \dot{x}_1 &= -x_1 + x_2 - x_1^2 x_2 \\ \dot{x}_2 &= -x_1 + x_1^2 \end{aligned}$$

$b \in \perp(e_1)$, then $A = Dc_1 b^T$. Defining $V(x) \triangleq x^T [Dc_1]_1$ implies $\dot{V}(x) = c^T x [Dc_1]_1^T D x$
 $= (c^T x) c^T [J^T D^T J D] x = |D| (c^T x)^2$ from Fact B.2. Thus $\dot{V} \geq 0$ (since $|D| \neq 0$ implies
 $|D| > 0$ for non-nodal D) with equality only for $x \in \perp(c)$. If e_2 is not an eigen-
vector of A then a complete half trajectory cannot remain on $\perp(c)$, hence by
Krasovskii's extension of Lyapunov's First Instability Theorem [3] the origin
is unstable. If $Ae_2 \in \perp(e_2)$ then $D = \alpha I$ and the field is purely quadratic on
 $\perp(e_1)$ in the direction $\perp(e_1)$, hence the origin is unstable.

Case (ii) $|D| = 0$: Since a singular non-nodal matrix is x -critical, we have
 $D = dd^T$ for some $d \in \mathbb{R}^2$. If $Ad \notin \perp(d)$ then the proof is identical to that of
case (ii) in Lemma 4.3. If $|A| = 0$ and $Ad \in \perp(d)$ then either $Ad = B(d) = 0$ or
 $Ax \in \perp(B(x))$ for all $x \in \mathbb{R}^2$ with off-origin equilibria in either case according
to Proposition 4.1. If $|A| \neq 0$ and $Ad \in \perp(d)$ then $A^{-1}d \in \perp(d)$ and $A^{-1}D = \gamma dd^T$
($\gamma \in \mathbb{R}$). Since this is not a nodal matrix, it need not be considered in this
proof. \square

In direct consequence of Lemmas 4.1-4 we may state the following necessary
conditions for a.s.l. of (2).

Proposition 4.3: The following conditions

- (i) A has eigenvalues in $\overline{\mathbb{C}^-}$
- (ii) $B(x) = c^T x D x$
- (iii) D is not nodal
- (iv) either $A^{-1}D$ or $D^{-1}A$ exists and is not nodal

are necessary for system (2) to be a.s.l.

c. Some Sufficient Conditions for Asymptotic Stability in the Large:

According to Proposition 4.3 system (2) must be of the form

$$\dot{x} = Ax + c^T x D x \tag{6}$$

where A is stable, D is not nodal and $D^{-1}A$ or $A^{-1}D$ is not nodal. In this section we

derive some sufficient conditions for a.s.l. of (6) under the more restrictive assumption that D is focal.

Corollary 4.1: If D is focal then (6) has no off origin equilibrium states if and only if $D^{-1}A$ is either focal or x -critical where $x \in \perp(c)$ when $|A| \neq 0$ and $x \notin \perp(c)$ when $|A| = 0$.

Proof: By Lemma 4.4 $D^{-1}A$ must be either focal or critical. If it is critical but not x -critical then $D^{-1}A = \alpha I$ and $B(x) \in \perp(Ax)$ for $x \in \mathbb{R}^2$ with resulting off-origin equilibrium states. If $D^{-1}A$ is x -critical then $B(y) \in \perp(Ay)$ if and only if $y \in \perp(x)$. Under this condition $|A| = 0$ if and only if $Ax = 0$. Since $B(x) = 0$ if and only if $x \in \perp(c)$ we require $x \notin \perp(c)$ when $Ax = 0$ and $x \in \perp(c)$ when $Ax \neq 0$ to insure against an off origin equilibrium state according to Proposition 4.1. \square

Example 4.4 presents a system which satisfies the necessary conditions given in Proposition 4.3 with D and $D^{-1}A$ chosen to be focal matrices. Since this system has unbounded solutions it is apparent that further restrictions must be placed upon A and D to obtain sufficient conditions for a.s.l.

Example 4.4:

$$\begin{bmatrix} \dot{x}_1 \\ \dot{x}_2 \end{bmatrix} = \begin{bmatrix} -1 & +1 \\ -1 & -1 \end{bmatrix} \begin{bmatrix} x_1 \\ x_2 \end{bmatrix} + x_1 \begin{bmatrix} 2 & -1 \\ 1 & +2 \end{bmatrix} \begin{bmatrix} x_1 \\ x_2 \end{bmatrix} \quad (\text{Figure 7}) \quad (7)$$

Along the line $x_1 = 0$ the quadratic part of (7) vanishes. Hence in the vicinity of this line the influence of the linear part is felt for arbitrarily large values of $\|x\|$. Considering the field along the lines $x_1 = 1$ and $x_1 = 1 + \epsilon$ ($\epsilon > 0$) for large positive values of x_2 we have

$$\begin{aligned} \dot{x}_1 &= 1 & \text{and} & & \dot{x}_1 &= (1+\epsilon)^2 - \epsilon x_2 \\ \dot{x}_2 &= x_2 & & & \dot{x}_2 &= (1+\epsilon)\epsilon + (1+2\epsilon)x_2 \end{aligned}$$

respectively. Note that x_2 increases in both cases while x_1 changes direction. Hence along the strip $1 < x_1 < 1 + \epsilon$ and $x_2 \gg \frac{1}{\epsilon}$ solutions grow in an unbounded fashion.

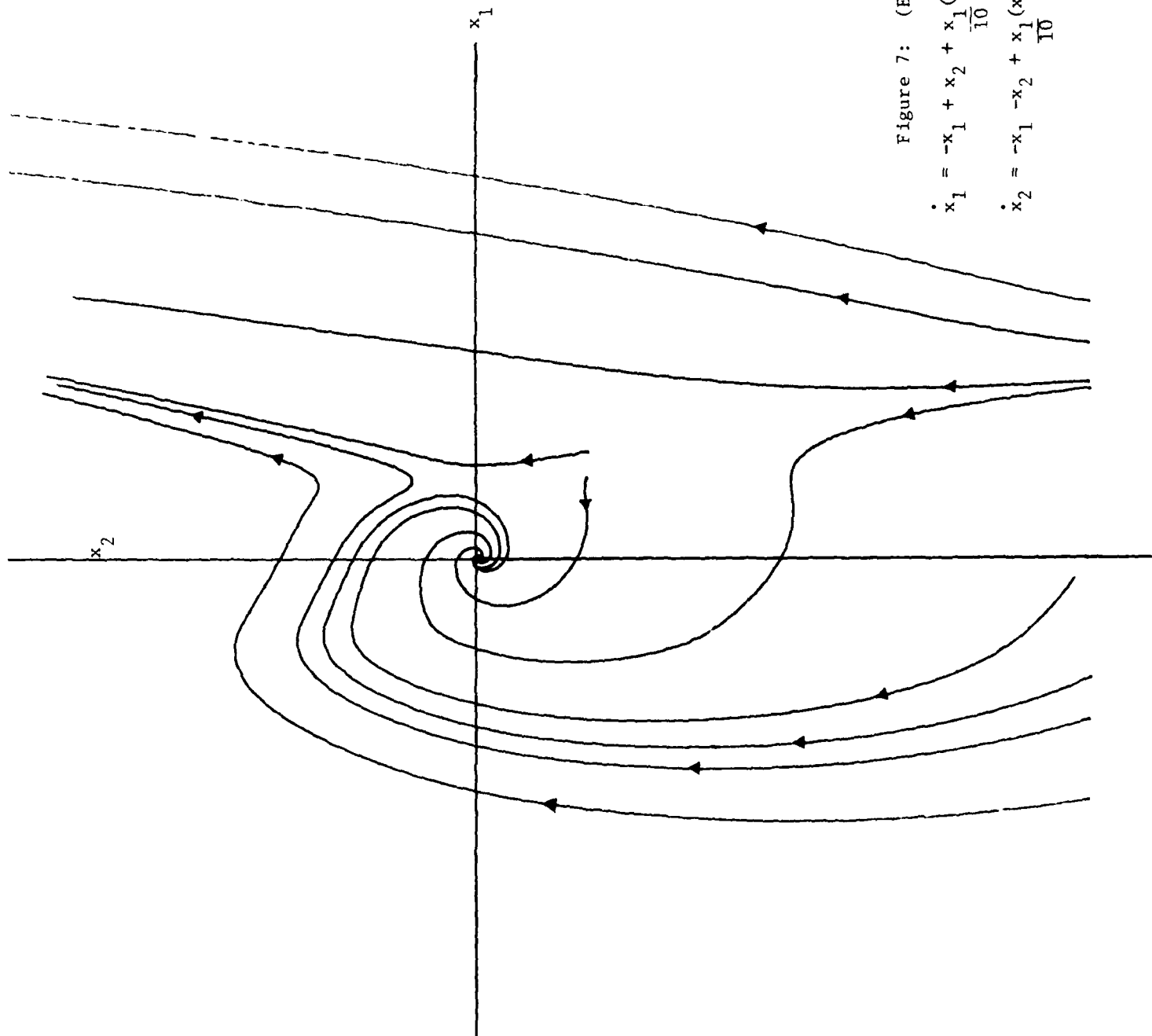

Figure 7: (Example 4.4)

$$\dot{x}_1 = -x_1 + x_2 + \frac{x_1}{10}(2x_1 - x_2)$$

$$\dot{x}_2 = -x_1 - x_2 + \frac{x_1}{10}(x_1 + 2x_2)$$

In this example the behavior of the field along the line $x_1 = 1$ is crucial to the existence of unbounded solutions. Lemmas 4.5 and 4.6 and their consequences address the significance of this affine line in the general case.

Lemma 4.5: For any pair of matrices, $A, D \in \mathbb{R}^{2 \times 2}$ and any $x \in \mathbb{R}^2$, if $\alpha(x) \triangleq -|Ax, x|$, $\delta(x) \triangleq |Dx, x|$ and $\eta(x) \triangleq -|Ax, Dx|$ then x is an eigenvector of the matrix $\delta(x)A + \alpha(x)D$ with corresponding eigenvalue $\eta(x)$.

Proof: Since $|(\delta(x)A + \alpha(x)D)x, x| = \delta(x)|Ax, x| + \alpha(x)|Dx, x| = 0$ we have

$$[\delta(x)A + \alpha(x)D]x = \eta(x)x \text{ for some real valued function } \eta(x). \text{ But } x^T x \eta(x) = x^T [\delta(x)A + \alpha(x)D]x = \begin{vmatrix} x^T Ax & x^T Dx \\ x^T JAx & x^T JDx \end{vmatrix} = \begin{vmatrix} [x, J^T x]^T [Ax, Dx] \end{vmatrix} = -x^T x |Ax, Dx| \text{ hence } \eta(x) = -|Ax, Dx|.$$

Lemma 4.6: The quadratic form $|Ax, Dx|$ is sign definite if and only if $D^{-1}A$ exists and is focal, and semi-definite if and only if either $D^{-1}A$ or $A^{-1}D$ exists and is x -critical.

Proof: $|Ax, Dx|$ is sign-definite if and only if it is never zero for $x \neq 0$, in which case $|D| \neq 0$ and $|Ax, Dx| = |D| |D^{-1}Ax, x| \neq 0$, which is equivalent to the statement that $D^{-1}A$ exists and is focal. Since it is a quadratic form $|Ax, Dx|$ is semi-definite if and only if it vanishes on exactly one line through the origin.

In this case either $|A| \neq 0$ or $|D| \neq 0$ (otherwise the form would vanish on at least two lines) and $|Ax, Dx| = |D| |D^{-1}Ax, x| = 0$ on one line uniquely is equivalent to the statement that $D^{-1}A$ exists and is x -critical, with a similar statement for $|A| \neq 0$. \square

Corollary 4.2: If D is focal and $D^{-1}A$ is focal (x -critical) then there exists a continuous functional $\mu(x)$ such that the pencil $A + \mu(x)D$ takes eigenvalues either in \mathbb{R}^- or \mathbb{R}^+ ($\overline{\mathbb{R}^-}$ or $\overline{\mathbb{R}^+}$) exclusively, and takes x as an eigenvector for all $x \in \mathbb{R}^2$.

Proof: If D is focal then $\delta(x) = |Dx, x| \neq 0$, hence defining $\mu(x) \triangleq \frac{\alpha(x)}{\delta(x)}$ implies $\mu(x)$ is continuous and x is an eigenvector of $A + \mu(x)D$ with eigenvalue $\lambda(x) \triangleq \frac{\eta(x)}{\delta(x)}$ by Lemma 4.5. If $D^{-1}A$ is focal (x -critical) we have $\eta(x)$ sign definite (semi-definite) from Lemma 4.6. \square

In system (6) the quadratic part vanishes along $\iota(c)$ and the influence of the linear part is felt in the neighborhood of this line even for large values of x as

in example 4.4. If we define $\mu_0 \stackrel{\Delta}{=} \mu(c_{\perp})$ then by Corollary 4.2 the field along the affine line $c^T x = \mu_0$ is given as $f(x) = M_0 x$ where $M_0 \stackrel{\Delta}{=} A + \mu_0 D$ is linear and takes c_{\perp} as an eigenvector with corresponding eigenvalue $\lambda_0 \stackrel{\Delta}{=} \frac{\eta(c_{\perp})}{\delta(c_{\perp})}$. * Lemma 4.7 demonstrates that the sign of this eigenvalue is a crucial indicator of a.s.l. behavior of system (6).

Lemma 4.7: If D is focal and $D^{-1}A$ is focal or x -critical then system (6) is not a.s.l. when $A + \mu(x)D$ takes eigenvalues in $\overline{\mathbb{R}^+}$.

Proof: If $A + \mu(x)D$ has positive eigenvalues then μ_0 cannot be zero since A has negative eigenvalues. Moreover, $\sigma(M_0) = \{\lambda_0, \delta_0\} \subseteq \overline{\mathbb{R}^+}$ with $M_0 c_{\perp} = \lambda_0 c_{\perp}$ from corollary 4.1 hence $c^T M_0 = \delta_0 c^T$ from Fact B.1. On the affine line $\{x | c^T x = \mu_0\}$ we have $f(x) = M_0 x = M_0(\mu_0 c + \eta c_{\perp})$ $\eta \in \mathbb{R}$ and hence $\mu_0 c^T f(x) = \mu_0^2 \delta_0 \geq 0$. If $\delta_0 > 0$ then the half-plane separated from the origin is positive invariant. If $\delta_0 = 0$ then the affine line is itself invariant. In either case, the system is not a.s.l. \square

Conversely, it is easy to show that system (6) is a.s.l. when the pencil $A + \mu(x)D$ is stable if we insure against off-origin equilibrium states according to Corollary 4.1.

Proposition 4.4: The following conditions

- (i) A has eigenvalues in $\overline{\mathbb{C}^-}$;
- (ii) $B(x) = c^T x D x$;
- (iii) D is focal and $D^{-1}A$ is either focal or x -critical where $x \in \perp(c)$ iff $|A| \neq 0$;
- (iv) $A + \mu(x)D$ has eigenvalues in $\overline{\mathbb{R}^-}$;

are sufficient for (2) to be a.s.l.

This result is obtained by constructing an arbitrarily large neighborhood of the origin and demonstrating that it is positive-invariant. Since D is focal, any trajectory of the linear system (5) - $\dot{x} = Dx$ - contains a spiral, Δ , corresponding to one period of oscillation whose endpoints fall on the same side of the same line

* Here and in the sequel we assume with no loss of generality that $\|c\| = 1$ in system (6).

through the origin of the phase plane. Joining these endpoints with the line segment Λ yields a closed curve surrounding the origin defining the neighborhood, N , as depicted in Figure 8. The conditions of the proposition imply that the linear field is always directed toward the interior of N on Δ , while the entire field is directed toward the interior on Λ irrespective of the orientation of its linear part.

Proof: Let $\sigma(D) = \{\alpha + i\beta, \alpha - i\beta\}$ where we assume $\alpha \leq 0$ by the proper choice of c (as in Lemma 3.2) with no loss of generality. Choose an orientation for J such that $x^T J^T D x > 0$. Define $\Delta \triangleq \{\rho e^{tD} c \mid t \in [0, \frac{\beta}{2\pi}]\}$ with endpoints ρc and $\rho e^{D\beta/2\pi} c = \rho \gamma c$ for some $\gamma \in [0, 1]$ since $\alpha \leq 0$ and $\frac{\beta}{2\pi}$ is the natural frequency of (5).^{*} Further define $\Lambda \triangleq \{\zeta c \mid \zeta \in [\gamma\rho, \rho]\}$ to close the boundary of N as depicted in Figure 8.

The scalar, ρ , will be chosen below. The normal vector to the curve Δ at any point x is given as $n_{\Delta}(x) \stackrel{\Delta}{=} J D x$ and this normal is directed into the interior of N since $x^T n_{\Delta}(x) = x^T J D x = -x^T J^T D x < 0$. Similarly, the interior directed normal on Λ is given by $n_{\Lambda}(x) = J c$. It now suffices to show that $n_{\Lambda}^T(x) f(x)$ and $n_{\Delta}^T(x) f(x)$ are non-negative for $x \in \Lambda, \Delta$ respectively. The first inequality follows since $x \in \Lambda$ implies $x = \zeta c$

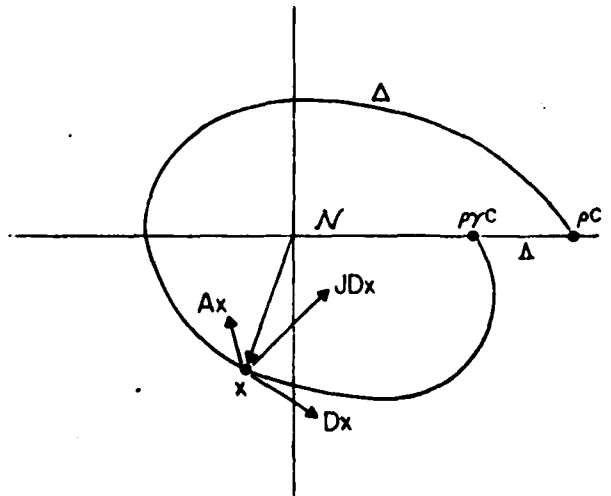

Figure 8

$\zeta \in [\gamma\rho, \rho]$ hence $n_{\Lambda}^T(x) f(x) = c^T J^T [\zeta A c + \zeta^2 D c] = \zeta [c^T J^T A c + \zeta c^T J^T D c]$ which is always positive for large ρ since $c^T J^T D c > 0$. To see the second inequality holds note $n_{\Delta}(x)^T f(x) = x^T D^T J^T [A x + c^T x D x] = x^T D^T J^T A x$. But $x^T D^T J^T A x$ must have the same sign as $x^T J^T D x$ since $\frac{x^T D^T J^T A x}{x^T J^T D x} = \frac{|A x, D x|}{|D x, x|} = -\lambda(x) \geq 0$ from Corollary 4.2.

Since ρ may be arbitrarily large in the above argument, we have shown that all solutions to (6) are bounded. If $c^T J^T A c > 0$ then the argument holds for all values of ρ and the proof is complete. If $c^T J^T A c < 0$ then it is easy to show that no limit cycles exist. Since the conditions of this proposition exclude off-origin equilibrium states as well, the boundedness of solutions implies that the origin is a.s.l. \square

^{*} Note: if $\gamma = 1$ then $\alpha = 0$ and D is skew-symmetric in some basis for which $V = x^T x$ is a Lyapunov function - i.e. $\dot{V} = x^T A x < 0$ under these hypotheses.

d. Special Cases - Critical Matrix D:

Propositions 4.3 and 4.4 give necessary and sufficient conditions respectively for a.s.l. of system (2). In both cases $B(x) = c^T x D x$ so that system (2) can be described by (6). The necessary conditions stipulate that the matrix D be non-nodal while the sufficient conditions in Proposition 4.4 are given for the case when D is a focal matrix. To complete the investigation of the stability properties of (2) we consider in this section system (6) when D is critical. This class is most easily treated by distinguishing between the cases when D is non-singular and D is singular.

The case when $|D| \neq 0$ closely resembles that analyzed earlier in section 4c where D is focal but $D^{-1}A$ is critical in that the stability properties of both systems are seen to depend on the vector c.

D Critical and Non-Singular:

Lemma 4.8: If D is critical and non-singular then a necessary condition for (6) to be a.s.l. is that D be c_1 -critical.

This Lemma is proved by demonstrating the existence of a positive invariant region disconnected from the origin. If $V(x) \triangleq \frac{1}{2} (x-m)^T P (x-m) - \gamma$, for some constant vector m, matrix P, and scalar γ , then a separation of the region $V(x) > 0$ can be shown to be contained in the region $\dot{V}(x) > 0$ demonstrating that the origin is not a.s.l. according to Proposition 4.2.

Proof: If D is critical but not

c_1 -critical there exists a vector $e \in \mathbb{R}^2$ such that $De = \lambda e$, $\lambda > 0$ and $c^T e > 0$.

From Fact A.4 choose $P = [e_1 (e_1 - \epsilon e)^T]_s$ such that $c_1 \notin C_0(P) \subseteq C_0([PD]_s)$ and we may choose $m \in C_0(P)$ with $c^T m > 0$. Define $V(x) \triangleq 1/2 (x-m)^T P (x-m) - \gamma$ for some $\gamma \in \mathbb{R}$ to be chosen below. The

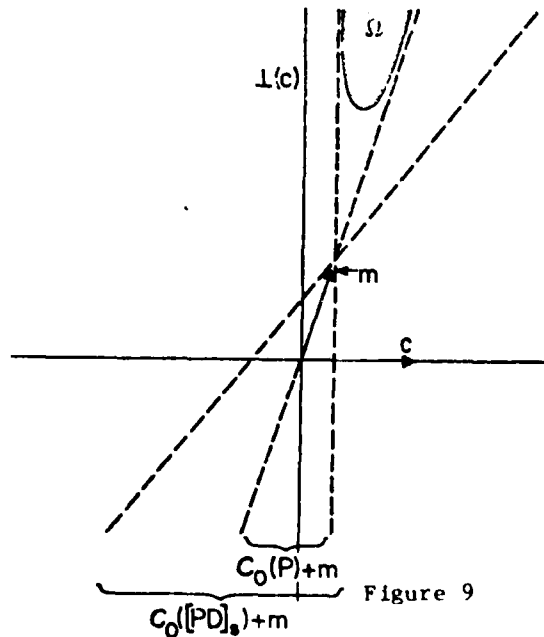

Figure 9

region $V(x) > 0$ is depicted in Figure 9 and contains the open set Ω consisting of those elements $x \in V^{-1}[\mathbb{R}^+]$ for which $c^T x > 0$. Formally, $C_Y(P) + m = V^{-1}[\mathbb{R}^+]$ and $\Omega \stackrel{\Delta}{=} [C_Y(P) \cap H_0(c)] + m$ separates $V^{-1}[\mathbb{R}^+]$ as shown in Fact A.3. If $y \stackrel{\Delta}{=} x - m$ then $x \in V^{-1}[\mathbb{R}^+]$ iff $y \in C_Y(P)$. Since $\dot{V}(x) = (x-m)^T P \dot{x} = y^T P \dot{y}$ we have from (6)

$$\dot{V}(y) = c^T y \ y^T P D y - \alpha(y)$$

where $\alpha(y)$ is a functional with linear and quadratic terms. Since $y^T P D y > 0$ when $y \in C_Y(P)$, $\dot{V}(y) > 0$ on that set iff $c^T y > \frac{\alpha(y)}{y^T P D y}$. Since $\alpha(y)$ can be shown to be negative on the common boundary of $C_0(P)$ and $C_0([PD]_S)$ in the half-plane $c^T x > 0$ - i.e. on $(e) \cap H_0(c)$ - it follows from Fact A.5 that a $\gamma \in \mathbb{R}^+$ exists such that the inequality holds for $y \in C_Y(P) \cap H_0(c)$. This is equivalent to the statement $\dot{V}(x) > 0$ for $x \in \Omega$.

Since Ω separates $V^{-1}[\mathbb{R}^+]$ and $\dot{V}(x) > 0$ in Ω , Ω is positive-invariant by Proposition 4.2. Since $0 \notin \Omega$ the system is not a.s.l. \square

Lemma 4.9: If D is c_1 -critical and non-singular a necessary condition for (6) to be a.s.l. is that $D^{-1}A$ be

either (i) focal

or (ii) singular and x -critical where $x \notin \perp(c)$.

Proof: By Lemma 4.4, (6) is not a.s.l. when $D^{-1}A$ is nodal. The result follows by showing that the cases where $D^{-1}A$ is critical and either non-singular or c_1 -critical are not a.s.l.

If $D^{-1}A$ is critical and non-singular with eigenvector $x \notin \perp(c)$ then $B(x) \in \perp(Ax)$, $B(x) \neq 0$ and $Ax \neq 0$. Hence an off-origin equilibrium exists by Proposition 4.1.

If $D^{-1}A$ is c_1 -critical then c_1 is also an eigenvector of A since D is c_1 -critical. Under the change of basis $y \stackrel{\Delta}{=} [c_1, c]^{-1} x$ equation (6) yields $\dot{y}_2 = y_2(d_{22}y_2 + a_{22})$. Since $d_{22} \neq 0$ the system has unbounded solutions. \square

Corollary 4.3: Let D be c_1 -critical with eigenvalue $\gamma < 0$. If $D^{-1}A$ is focal or x -critical then the pencil $A + \nu(x)D$ has eigenvalues in $\overline{\mathbb{R}^-}$ for all $x \notin \perp(c)$ iff

$$c^T A c_1 \ x_1^T D x_1 \geq 0.$$

Proof: For $x \notin \perp(c)$, $A + \mu(x)D$ is defined and has an eigenvalue $\lambda(x) = \frac{-|Ax, Dx|}{|Dx, x|}$

according to Lemma 4.5 where λ is sign definite (or semi-definite) according to Lemma 4.6. If $|Dx, x| = x_{\perp}^T Dx \geq 0$ then $\lambda(x) \leq 0$ iff $|Ax, Dx| \geq 0$. Since $|Ac_{\perp}, Dc_{\perp}| = \gamma |Ac_{\perp}, c_{\perp}| = -\gamma c_{\perp}^T Ac_{\perp}$ and $\gamma < 0$ the result follows. \square

These results lead to the following necessary and sufficient conditions for a.s.l. when D is critical and non-singular.

Proposition 4.5: If D is critical and non-singular then system (6) is a.s.l. if and only if

- (i) D is c_{\perp} -critical
- (ii) $D^{-1}A$ is either focal or $D^{-1}A$ is singular and x -critical where $x \notin \perp(c)$
- (iii) For some $x \in \mathbb{R}^2$ the pencil $A + \mu(x)D$ has a negative real eigenvalue.

Proof: As in the proof of Proposition 4.4 we may assume that $Dc_{\perp} = \gamma c_{\perp}$ where $\gamma < 0$ and $x_{\perp}^T Dx \geq 0$ with no loss of generality. Hence, under the conditions (i) and (ii) condition (iii) is equivalent to the condition $c_{\perp}^T Ac_{\perp} > 0$ by Corollary 4.3, or $(Dx)_{\perp}^T Ax \geq 0$ by Lemma 4.5 and 4.6.

Necessity: By Lemma 4.8 and 4.9 we require (i) and (ii). If (iii) does not hold then $c_{\perp}^T Ac_{\perp} < 0$ as shown above. In this case the proof is identical to that in Case (ii) of Lemma 4.3, where (6) is shown to be not a.s.l. by the construction of a positive-invariant set, $C_{\gamma}(P)$, disconnected from the origin.

Sufficiency: is shown by constructing an arbitrarily large Jordan curve Ψ as depicted in Figure 10, such that the field at every point on the curve is directed towards the interior of the enclosed region N . Since D is c_{\perp} -critical the curve $e^{tD}x$, $t \in \mathbb{R}^+$, $x \in H_0(c)$ intersects $\Gamma(y)$ for all $y \notin \perp(c)$ (Figure 10a). The curve Ψ may then be expressed as the union (Figure 10b)

$$\Psi = \Lambda^- \cup \Delta^- \cup \Lambda^+ \cup \Delta^+ \cup \Gamma$$

where Δ^+ and Δ^- are segments of curves of the form $e^{tD}x$ and Λ^-, Λ^+ and Γ are line segments, all of which are defined as follows.

$$\Lambda^- \triangleq \{\eta(x_0 - tb) \mid t \in [0, t_1]\}; \Delta^- \triangleq \{\eta e^{-tD} x_1 \mid t \in [0, t_2]\}$$

$$\Lambda^+ \triangleq \{\eta(x_2 + tb) \mid t \in [0, t_3]\}; \Delta^+ \triangleq \{\eta e^{-tD} x_3 \mid t \in [0, t_4]\}$$

and $\Gamma \triangleq \{\eta(x_4 - \mu c) \mid \mu \in [0, \mu_4 - \mu_0]\}$

where $x_0 \triangleq -c_1 + \mu_0 c$; $b \triangleq c_1 + \epsilon_0 c$ $\epsilon_0 > 0$

$$\mu_0 \triangleq \max \left(\frac{c_1^T A c}{c_1^T D c}, \frac{c_1^T A c_1}{c_1^T D c_1} \right), \quad \eta \gg 1 \text{ and}$$

x_1, x_2, x_3 and x_4 are the end points of $\Lambda^-, \Delta^-, \Lambda^+$ and Δ^+ respectively. The parameters t_1 and t_3 are chosen so that Λ^+ and Λ^- cross $\perp(c)$, and t_2 is chosen so that $x_2 \in \perp(c_1 - \epsilon_1 c)$ where $0 < \epsilon_1 < \epsilon_0$. The parameters t_4 and μ_4 are such that the curve is closed at x_4 .

A family of such Jordan curves can be generated by changing the parameter η and the arguments given below apply to all members of the family for η sufficiently large.

As in the proof of Proposition 4.4 the field is directed into the interior of N on Δ^- and Δ^+ since $(Dx)_\perp^T A x \geq 0$ as shown above. The interior normal direction on Γ is c_1 and $c_1^T f(x) > 0$ since $c_1^T D c > 0$ and the quadratic term dominates the linear term of the field by the choice of μ_0 . On Λ^+ and Λ^- the linear field dominates, and is directed towards the interior of N since $c^T A c_1 > 0$ as shown above. \square

D Critical and Singular:

Proposition 4.6: If D is critical and singular then system (6) is a.s.l. iff $|A| \neq 0$ and $A^{-1}D = \gamma D$ for some $\gamma \in \mathbb{R}$, in which case the pencil $A + \mu(x)D$ has eigenvalues in \mathbb{R}^- when it is defined.

Proof: From Lemma 4.4, if $|D| = 0$ then $|A| \neq 0$ and $A^{-1}D$ is not nodal. Since $D = dd_1^T$ for some $d \in \mathbb{R}^2$, $A^{-1}D$ is nodal unless $A^{-1}d \in \perp(d)$ in which case $A^{-1}D = \gamma dd_1^T = \gamma D$ for some $\gamma \in \mathbb{R}$.

Conversely, if $D = dd_1^T$ and $A^{-1}D = \gamma dd_1^T$ then $Ad \in \perp(d)$. Under the change of basis $y \triangleq [d, d_1]^{-1} x$ we have $\tilde{A} = \begin{bmatrix} a_{11} & a_{12} \\ 0 & a_{22} \end{bmatrix}$, $\tilde{D} = \begin{bmatrix} 0 & 1 \\ 0 & 0 \end{bmatrix}$ hence $\dot{y}_2 = a_{22}y_2$ and

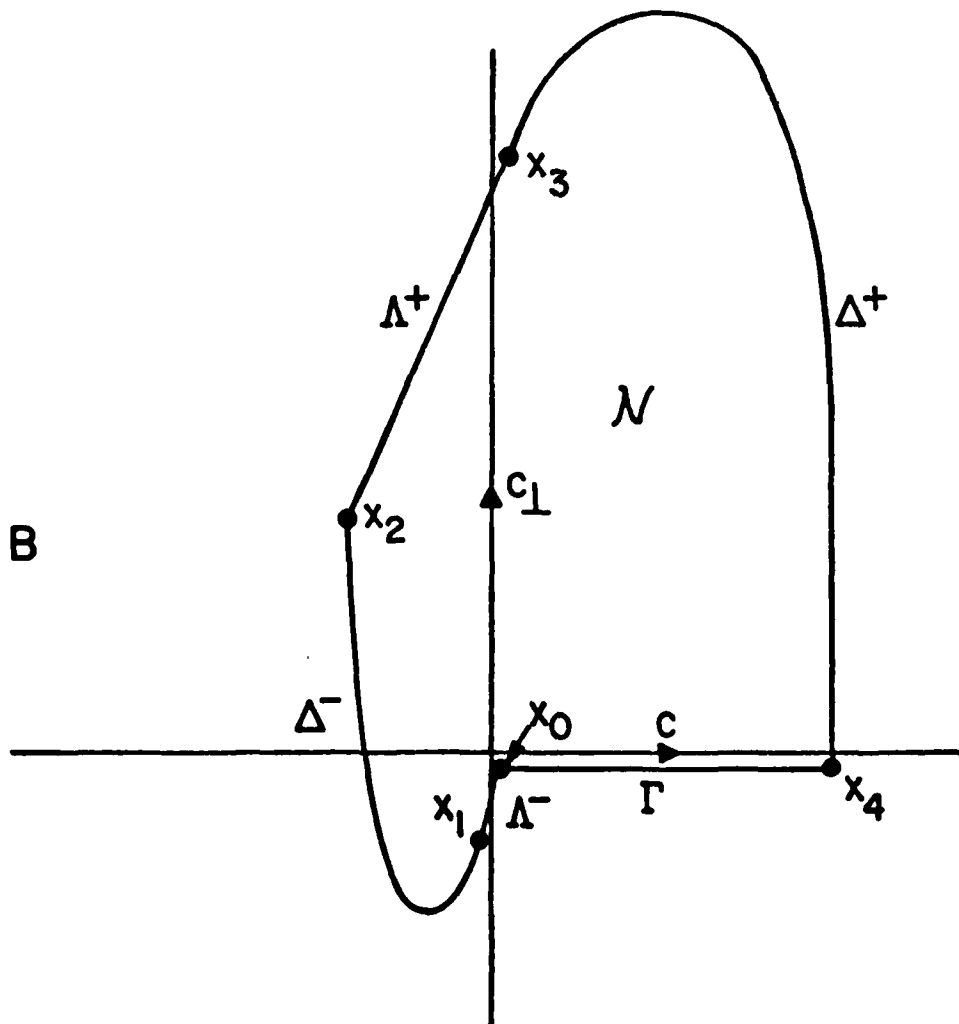
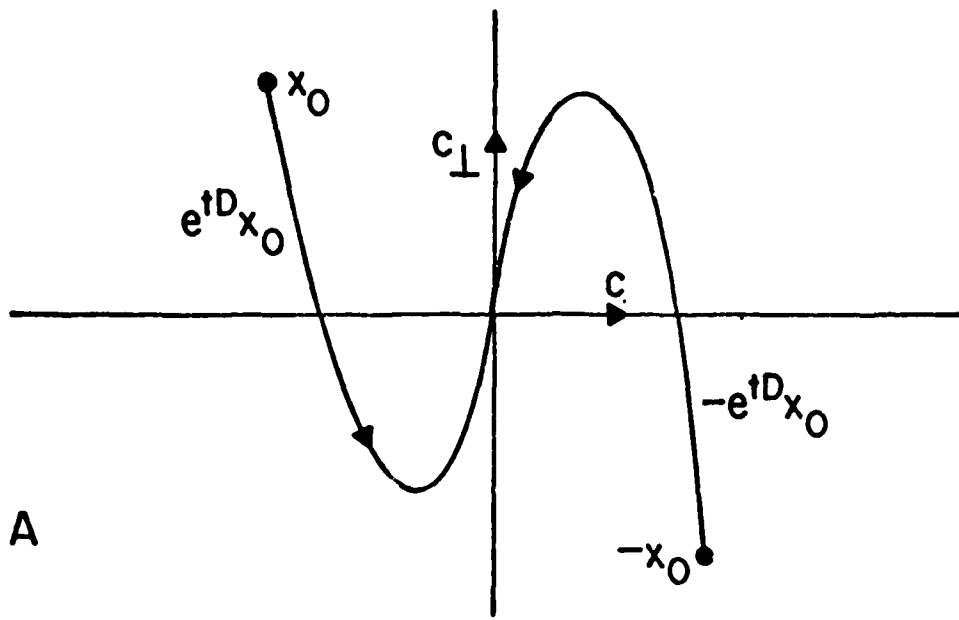

Figure 10

$y_2(t) = e^{a_{22}t} y_{20} \rightarrow 0$. In this case $\dot{y}_1 = (a_{11} + c_1 e^{a_{22}t} y_{20}) y_1 + a_{12} e^{a_{22}t} y_{20} + c_2 e^{2a_{22}t} y_{20}^2$ and $y_1(t) \rightarrow 0$. The system is a.s.l.

In the y coordinate system, $\tilde{A} + \mu(y)\tilde{D}$ has the eigenvalue

$$\lambda(y) = - \frac{|\tilde{A}y, \tilde{D}y|}{|\tilde{D}y, y|} = \frac{a_{22}y_2^2}{y_2^2} < 0$$

according to Lemma 4.5. \square

e. Summary of Results:

Sections 4 a-d have investigated the properties and conditions for a.s.l. of system (6) according to the scheme depicted in Figure 6. By Proposition 4.3 in section 4b matrices D , $A^{-1}D$ or $D^{-1}A$ cannot be nodal if system (6) is to be a.s.l.

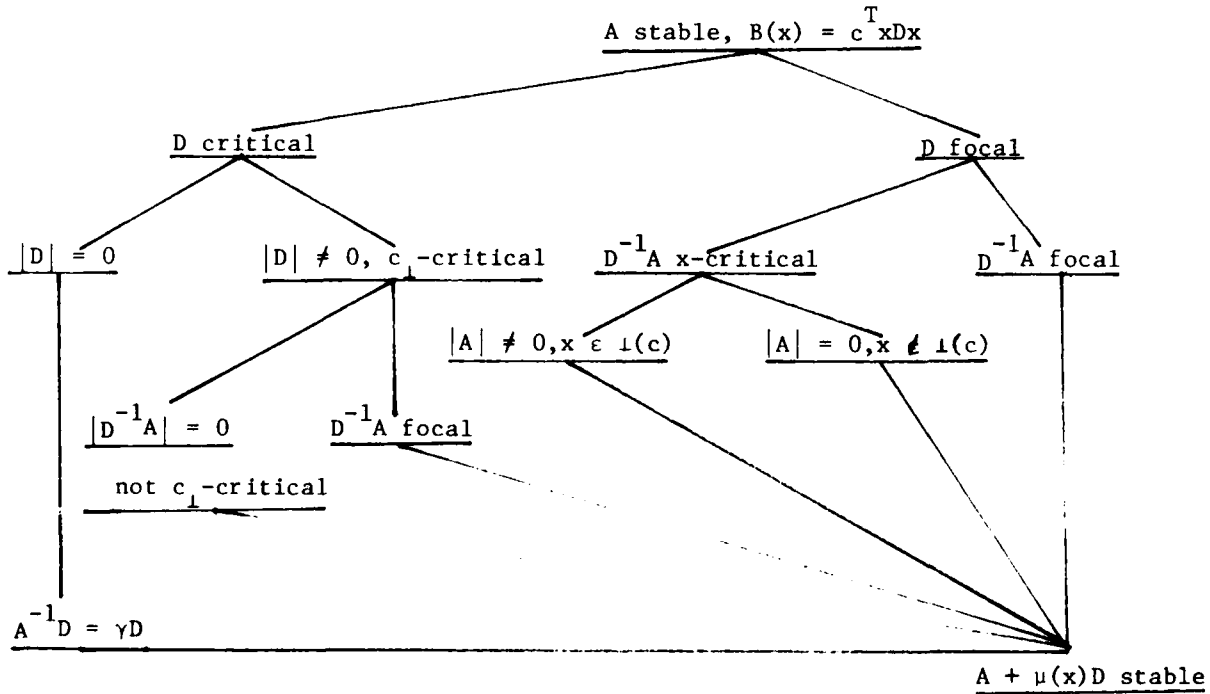

Figure 11

In section 4c, Proposition 4.4 specifies sufficient conditions for a.s.l. which are also seen to be necessary when applied strictly to the right branch of the tree in Figure 11, where D is focal. In section 4d Propositions 4.5 and 4.6 specify sufficient

conditions for a.s.l. which are also necessary when applied to the left branch of the tree where D is critical. The stability condition on the pencil $A + \mu(x)D$ is seen to have the intuitively appealing geometric interpretation that the perturbation of the pure quadratic field by the addition of the linear field must be directed toward the origin at every point. The results of sections 4 a-d lead to the central contribution of this paper given by Theorem 2.

Theorem 2: The following conditions are necessary and sufficient for a.s.l. of system (2):

- (i) the eigenvalues of A lie in $\overline{C^-}$.
- (ii) $B(x) = c^T x D x$
- (iii) D and $D^{-1}A$ or $A^{-1}D$ exist, are either focal or critical, and satisfy one of the following:
 - (a) D and $D^{-1}A$ are focal;
 - (b) D is focal and $D^{-1}A$ is x-critical where $x \in \perp(c)$ iff $|A| \neq 0$;
 - (c) D is c_{\perp} -critical and non-singular, and $D^{-1}A$ is focal;
 - (d) D is c_{\perp} -critical and non-singular, $D^{-1}A$ is singular and not c_{\perp} -critical;
 - (e) D is singular and $A^{-1}D = \gamma D$ for some scalar γ .
- (iv) if $\mu(x) \triangleq - \frac{|Ax, x|}{|Dx, x|}$ then the pencil $A + \mu(x)D$ has a negative real eigenvalue for some $x \in \mathbb{R}^2$.

Proof: Conditions (i), (ii), and the general statement of (iii) are necessary according to Proposition 4.3. Under these conditions (iv) is equivalent to the statement that $A + \mu(x)D$ has negative real eigenvalues for all $x \in \mathbb{R}^2$ where μ exists according to Lemmas 4.5 and 4.6. If D is focal then the additional condition (iiia) or (iiib) is necessary and sufficient according to Proposition 4.4. If D is non-singular and critical the additional condition (iiic) or (iiid) is necessary and sufficient according to Proposition 4.5. If D is focal then (i),(ii),(iiie) are necessary and sufficient according to Proposition 4.6. \square

Two examples of systems satisfying the conditions of Theorem 2 are given below with accompanying figures.

Example 4.5:

$$\text{a. } \dot{x} = \begin{bmatrix} -1 & 0 \\ 0 & -1 \end{bmatrix} x + x_1 \begin{bmatrix} 0 & -1 \\ 1 & 0 \end{bmatrix} x \quad (\text{Figure 12a})$$

$$\text{b. } \dot{x} = \begin{bmatrix} -1 & 2 \\ -2 & -1 \end{bmatrix} x + x_1 \begin{bmatrix} 1 & 1 \\ -1 & 1 \end{bmatrix} x \quad (\text{Figure 12b})$$

References

- [1] Koditschek, D. E. and Narendra, K. S., "The Stability of Second Order Quadratic Differential Equations," S & IS Report No. 7709, Yale University, Department of Engineering and Applied Science, November 1977.
- [2] Koditschek, D. E. and Narendra, K. S., "The Stability of Second Order Quadratic Differential Equations - Part II," S & IS Report No. 7805, Yale University, Department of Engineering and Applied Science, December 1978.
- [3] Hahn, W., Stability of Motion, Springer-Verlag, New York, 1967.
- [4] Royden, H. L., Real Analysis, MacMillan, London, 1968.

Acknowledgment

The authors would like to express their gratitude to one of the reviewers for his careful attention and helpful suggestions. This research was supported in part by the Office of Naval Research under Contract N00014-76-C-0017.

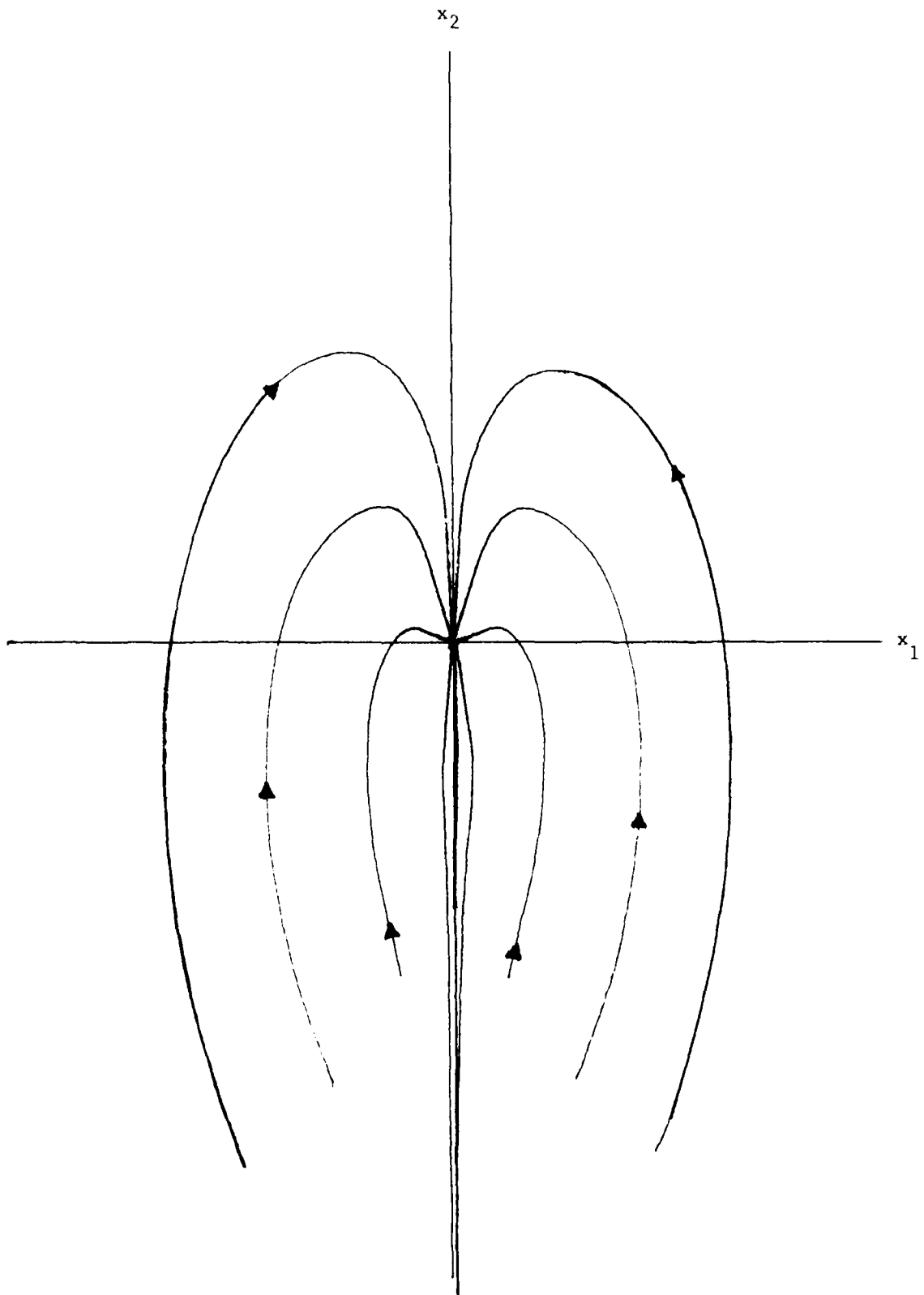
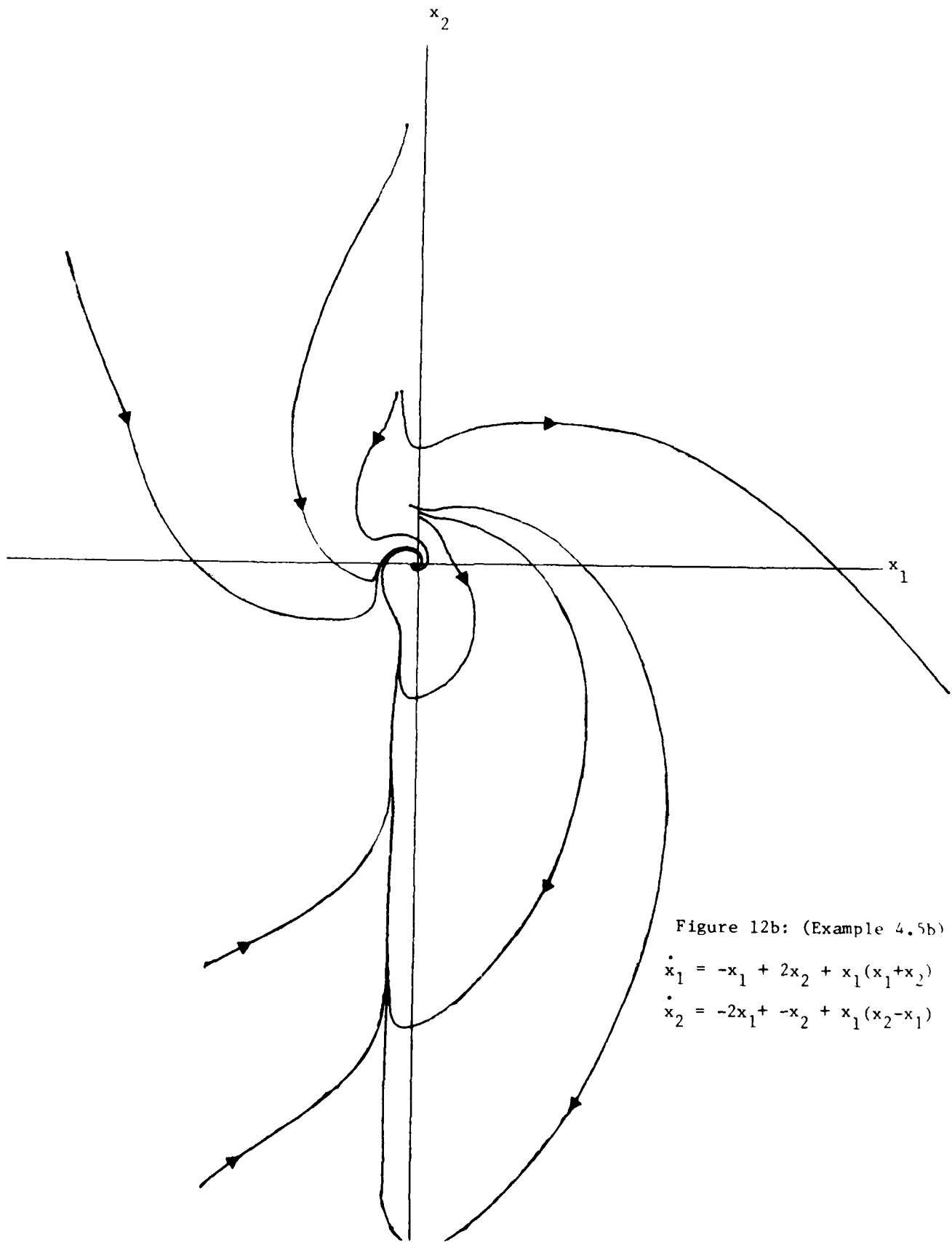

Figure 12a: (Example 4.5a)

$$\begin{aligned} \dot{x}_1 &= -x_1 - x_1 x_2 \\ \dot{x}_2 &= -x_2 + x_1^2 \end{aligned}$$



Appendix A

Some Geometrical Results in \mathbb{R}^2

Many of the apparently complicated proofs in the body of this paper are based upon some simple geometrical notions. Unfortunately the algebra and notation needed to make these concepts precise are unwieldy. This appendix presents the most important of these ideas as Facts A.1-5 of which A.4 and A.5 are proved in detail since they are used throughout the paper.

Definition A.1: If $\theta \subseteq \mathbb{R}^2$ is open, the boundary of θ is defined as

$$\partial\theta \triangleq \bar{\theta} - \theta$$

Fact A.1: Let $\theta \subseteq \mathbb{R}^2$ be open and separated by θ_1 . Then $\partial\theta_1 \subseteq \partial\theta$. If $\theta_1 \cup \theta_2 = \theta$ and $\theta_1 \cap \theta_2 = \phi$ this merely states that $\partial\theta_1 \cap \theta_2 = \phi$.

Definition A.2: Let e, \tilde{e} be linearly independent in \mathbb{R}^2 . Then

$$C_\gamma(e, \tilde{e}) \triangleq \{\alpha e + \beta \tilde{e} \mid \alpha\beta > \gamma \geq 0\}$$

$C_0(e, \tilde{e})$ defines a conical region in \mathbb{R}^2 . If $\gamma_1 > \gamma_2$ $C_{\gamma_1}(e, \tilde{e})$ is a proper subset of $C_{\gamma_2}(e, \tilde{e})$. The distance of the set $C_\gamma(e, \tilde{e})$ from the origin increases monotonically with γ and tends to infinity as γ tends to infinity.

An alternate description of $C_0(e, \tilde{e})$ and $C_\gamma(e, \tilde{e})$ uses e_\perp and \tilde{e}_\perp .

$$\begin{aligned} x \in C_0(e, \tilde{e}) & \text{ iff } -x \begin{bmatrix} e_\perp^T \\ \tilde{e}_\perp^T \end{bmatrix} x > 0 \\ x \in C_\gamma(e, \tilde{e}) & \text{ iff } \frac{-x \begin{bmatrix} e_\perp^T \\ \tilde{e}_\perp^T \end{bmatrix} x}{\left[\begin{bmatrix} e_\perp \\ \tilde{e}_\perp \end{bmatrix} \right]^2} > \gamma \end{aligned}$$

If $P \triangleq \frac{-\begin{bmatrix} e_\perp^T \\ \tilde{e}_\perp^T \end{bmatrix} x}{\left[\begin{bmatrix} e_\perp \\ \tilde{e}_\perp \end{bmatrix} \right]^2}$ then $C_\gamma(e, \tilde{e}) = C_\gamma(P)$ defined in section 3a.

Fact A.2: Let e, \tilde{e} and $x \in \mathbb{R}^2$. If \tilde{e} and x lie in the same half plane defined by (e) and $x \notin C_0(e, \tilde{e})$ then

$$C_0(e, \tilde{e}) \subseteq C_0(e, x).$$

Fact A.3: Let $c_{\perp} \notin C_0(e, \tilde{e})$. If $H_{\eta}(c) \triangleq \{x | c^T x > \eta\}$ as defined in section 3a, given an $\eta \geq 0$ there exists a $\gamma > 0$ such that

$$H_{\eta}(c) \cap C_{\gamma}(e, \tilde{e}) \text{ separates } C_{\gamma}(e, \tilde{e})$$

If $c_{\perp} \in \partial C_0(e, \tilde{e})$ then the above result holds only for $\eta = 0$.

Fact A.4: Let D be critical or nodal with $\sigma(D) = \{\lambda, \mu\}$ and $\lambda \geq |\mu|$. Then given any $c \in \mathbb{R}^2$ there exists an indefinite matrix P such that $c_{\perp} \notin C_0(P)$ and $C_0(P) \subseteq C_0([PD]_s)$.

Comment: Fact A.4 is used throughout the paper to prove that the given system is not a.s.l. The principal idea is to establish a region in \mathbb{R}^2 by the proper choice of

P, which is positive invariant. Embedding $C_0(P)$ in $C_0([PD]_s)$ establishes the positive invariance of one half of the cone $C_0(P)$ under the influence of the pure quadratic field. Fact A.4 states that if D is nodal or critical such an embedding is always possible.

Proof: Let $De = \lambda e$ and define $\tilde{e} \triangleq e + \epsilon e_{\perp}$ for some $\epsilon > 0$. Note $\tilde{e}_{\perp} = e_{\perp} - \epsilon e$.

Define $P \triangleq -[e_{\perp} \tilde{e}_{\perp}^T]_s$ to get

$$PD = -\frac{1}{2}[e_{\perp} \tilde{e}_{\perp}^T + \tilde{e}_{\perp} e_{\perp}^T]D = -\frac{1}{2}[e_{\perp} \tilde{e}_{\perp}^T D + \mu \tilde{e}_{\perp} e_{\perp}^T]$$

since $e_{\perp}^T D = \mu e_{\perp}^T$ from Fact B.1. Thus

$$[PD]_s = -[e_{\perp} g^T]_s$$

where $g = \frac{1}{2}[D^T + \mu I]\tilde{e}_{\perp}$. If $g \in \perp(e)$, then it directly follows that $0 = e^T g = -\epsilon/2(\lambda + \mu)e^T e$, hence $\lambda = -\mu$ and

$$C_0([PD]_s) = \mathbb{R}^2 - \perp(e) \supseteq C_0(P).$$

If $g \notin \perp(e)$ we consider the three cases where D is (i) critical but not x-critical (ii) x-critical and (iii) nodal.

In case (i) $D = \alpha I (\alpha > 0)$ and $PD = \alpha P$ so that $C_0(P) = C_0([PD]_s)$. For cases (ii) and (iii) we demonstrate that $C_0(P) \subseteq C_0([PD]_s)$ by the equivalent demonstration

that

$$C_0(e, \tilde{e}) \subseteq C_0(e, -g_1)$$

using the results of A.2.

Since $e_1^T g_1 = e^T g = -\epsilon/2(\lambda + \mu) < 0$ and $e_1^{T\sim} e = \epsilon e_1^T e_1 > 0$ it follows that \tilde{e} and $-g_1$ lie in the same half plane defined by $|e\rangle$. To show $-g_1 \notin C_0(e, \tilde{e})$ it suffices to show $0 > g_1^T P g_1 = -(g_1^T e_1)(\tilde{e}_1^T g_1)$. Since $g_1^T e_1 < 0$ from above, this follows if and only if $\tilde{e}_1^T g_1 = -\epsilon/2 e^T e (\lambda - \mu + \epsilon \frac{e_1^T D e}{e^T e}) < 0$. The last inequality is evidently true for small enough ϵ if D is nodal since $\lambda > |\mu|$. If D is x -critical then $\lambda - \mu = 0$ and the sign of $\tilde{e}_1^T g_1$ depends upon J - i.e. the orientation of $e_1 \stackrel{\Delta}{=} J e$.^{*} In either case $\tilde{e}_1^T g_1 < 0$ and $g_1 \notin C_0(e, \tilde{e})$. Thus, by Fact A.2

$$C_0(P) = C_0(e, \tilde{e}) \subseteq C_0(e, -g_1) = C_0([PD]_S).$$

To show that $c_1 \notin C_0(P)$ we note that $c_1^T P c_1 = -(c_1^T e_1)^2 + \epsilon (c_1^T e_1 e_1^T c_1) \leq 0$ for small enough ϵ . \square

Fact A.5: Let e, \tilde{e}, c, D and P be as in A.4. Let $\alpha(x) = x^T Q x + g^T x$ for arbitrary matrix Q and vector g (possibly 0) such that $e^T Q e > 0$. Then for some $\gamma \in \mathbb{R}$, there exists a separation, Ω , of $C_0(P)$ such that $\Psi(x) = \alpha(x) + c^T x x^T P D x > 0$ for $x \in \Omega$.

Comment: This fact is used to prove the existence of positive-invariant sets disconnected from the origin. If $\dot{x} = b + Ax + c^T x D x$ as in section 4 and

$$V(x) = \frac{1}{2} x^T P x - \gamma, \text{ then } \dot{V}(x) = \Psi(x).$$

Proof: If $x \in C_0([PD]_S)$ then $\Psi(x) > 0$ iff $c^T x > \theta(x)$ where $\theta(x) \stackrel{\Delta}{=} -\frac{\alpha(x)}{x^T P D x}$. We

first show for some $\gamma, \sup_{x \in C_\gamma(P)} \theta(x) = \theta_0 < \infty$. This follows since $|\theta(x)| < \infty$ as

$C_\gamma(P) \subseteq C_0([PD]_S)$, while on the common boundary

$$\partial C_0(P) \cap \partial C_0([PD]_S) = |e\rangle,$$

^{*} Unless $|D| = 0$ in which case $D = e e_1^T$ and $e_1^T D^T e = \|e\|^4$ regardless of the choice of J .

which is arbitrarily close to $\partial C_Y(P)$, we have $\alpha(x) > 0$ for $x = \beta e$ when $\beta^2 > \beta_0$, for some $\beta_0 \in \mathbb{R}$ since $e^T Q e > 0$.

Case (i) $e \notin \perp(c)$: By Fact A.2 there exists a γ such that $C_Y(P) \cap H_{\theta_0}(c)$ separates $C_Y(P)$. Hence defining $\Omega = C_Y(P) \cap H_{\theta_0}(c)$ yields the desired result.

Case (ii) $e \in \perp(c)$: Since $\alpha(x) > 0$ for $x = \beta e$, $\beta^2 > \beta_0$ by continuity $\alpha(x) > 0$ for $x = \beta e'$ $\beta^2 > \beta_1$ for some e' in a neighborhood of e contained in $C_0(P)$. Hence if

$$\delta \triangleq \max\{\beta_0, \hat{\beta}_1, \theta_0/c^T e', \theta_0/c_1^T e'\}$$

and $\theta_1 \triangleq c_1^T e' \delta > \theta_0$; $\theta_2 \triangleq c^T e' \delta > \theta_0$

then $\alpha(x) > 0$ in the rectangle $\Pi \triangleq \{x | c^T x \in [0, \theta_2] \text{ and } c_1^T x > \theta_1\}$. Choosing γ such that $\Omega \triangleq C_0(P) \cap H_{\theta_1}(c_1)$ separates $C_0(P)$ according to Fact A.2 we have

$$c^T x > 0 > \frac{-\alpha(x)}{x^T P D x} \text{ for } x \in \Omega \cap \Pi$$

while

$$c^T x > \theta_1 > \theta_0 > \frac{-\alpha(x)}{x^T P D x} \text{ for } x \in \Omega - \Pi \text{ as shown in Figure A.1. } \square$$

Comment: When $\perp(c)$ does not coincide with the common boundary of $C_0(P)$ and $C_0([PD]_s)$ it is possible to separate $C_Y(P)$ using the half plane $H_{\theta_0}(c)$ as shown in case (i).

When $\perp(c)$ coincides with this boundary, the proof is more involved as shown in case (ii). The region Ω is expressed as the union

$$\Omega = (\Pi \cap \Omega) \cup (H_{\theta_1}(c_1) \cap \Omega)$$

and it is shown that Π and $H_{\theta_1}(c_1)$ have the desired property i.e. $c^T x > \frac{-\alpha(x)}{x^T P D x}$, or $\psi(x) > 0$.

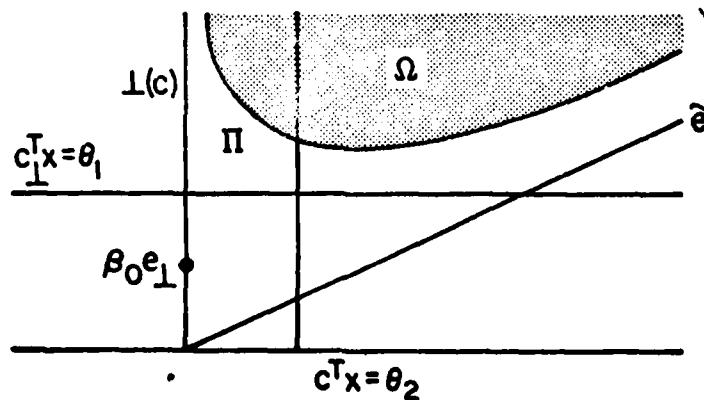

Figure A.1

Appendix B

Some Properties of (2x2) Matrices

Fact B.1: If x is an eigenvector of the matrix A , x_{\perp} is an eigenvector of the matrix A^T . If $\sigma(A) = \{\lambda, \mu\} \subseteq \mathbb{R}$ and $Ax = \lambda x$, then $A^T x_{\perp} = \mu x_{\perp}$.

Proof: $(Ax, x_{\perp}) = (\lambda x, x_{\perp}) = (x, A^T x_{\perp}) = 0$ where (x, y) is the inner product of the vectors x and y . Hence x_{\perp} is an eigenvector of A^T .

Let the eigenvalue of A^T corresponding to x_{\perp} be α and let the eigenvector of A corresponding to the eigenvalue μ be y . $A^T x_{\perp} = \alpha x_{\perp}$; $Ay = \mu y$.

$$(Ay, x_{\perp}) = (\mu y, x_{\perp}) = (y, A^T x_{\perp}) = (y, \alpha x_{\perp})$$

Hence

$$(\mu - \alpha)y^T x_{\perp} = 0$$

Since the eigenvectors y and x are independent $\mu = \alpha$. \square

Fact B.2: If A is a non-singular matrix and $J = \begin{bmatrix} 0 & -1 \\ 1 & 0 \end{bmatrix}$ then $A^{-1} = \frac{1}{|A|} J^T A^T J$. \square

Proof: If $J = \begin{bmatrix} 0 & -1 \\ 1 & 0 \end{bmatrix}$, $A = \begin{bmatrix} a_{11} & a_{12} \\ a_{21} & a_{22} \end{bmatrix}$ $J^T A^T J = \begin{bmatrix} a_{22} & -a_{12} \\ -a_{21} & a_{11} \end{bmatrix}$. \square

END

DATE
FILMED

5 8 1

DTIC